

**Model K1600**

---

# **Logic Waveform Analyzer**

## ***USER'S MANUAL***

Publication Number 0300-0004-10

Rev. 50

*August 1992*

**Model K1600**  
**Logic Waveform Analyzer**  
  
***USER'S MANUAL***



1860 Barber Lane  
Milpitas, CA 95035  
800-934-2466 • 408/435-7800  
408/435-7970 FAX

**Copyright © 1992 by Biomation Corporation.**

**All rights reserved. No part of this publication may be reproduced without written permission from Biomation Corporation.**

**Printed in the U.S.A.**

# PREFACE

This manual explains the operation of the Biomation Logic Waveform Analyzer (Model K1600). The K1600 monitors up to 16 electronic signals simultaneously to help solve software and/or hardware problems in digital systems.

By using the powerful features like combinational logic triggering and the high-resolution repetitive mode you will be able to isolate problems much more quickly than would be possible with other test equipment.

If you require any assistance on this product, please call the Biomation Applications Engineering Department on the toll-free hot line number: 800-934-2466.

The material in this manual reflects the K1600 hardware and software level which was valid at the time of publication, but is subject to change without notice.

Copies of this manual and other Biomation publications may be obtained from your Biomation sales office, representative, or distributor serving your locality.



# WARNING

This equipment has not been tested to show compliance with new FCC Rules (47 CFR Part 15) designed to limit interference to radio and TV reception. Operation of this equipment in a residential area is likely to cause unacceptable interference to radio communication requiring the operator to take whatever steps are necessary to correct the interference.

The following procedures may help alleviate the Radio or Television Interference problems:

1. Reorient the antenna of the receiver receiving the interference.
2. Relocate the equipment causing the interference with respect to the receiver (move or change relative position).
3. Reconnect the equipment causing the interference into a different outlet so the receiver and the equipment are connected to different branch circuits.
4. Remove the equipment from the power source.

**NOTE:** The user may find the following booklet prepared by the FCC helpful: *How to Identify and Resolve Radio-TV Interference Problems*, available from the U.S. Government Printing Office, Washington, DC 20402, Stock Number 004-000-0034504.

# CONTENTS

<b>1</b>	<b>INTRODUCTION</b>	
	OVERVIEW . . . . .	1-1
	Introduction . . . . .	1-1
	Benchtop Applications . . . . .	1-2
	ATE Applications . . . . .	1-3
	MAIN FEATURES . . . . .	1-4
	Analog Features . . . . .	1-4
	Digital Features . . . . .	1-4
	Triggering Features . . . . .	1-4
	Menu and Display Features . . . . .	1-5
	Input Probes . . . . .	1-6
	Menu Setup and Data Storage . . . . .	1-7
	Other Features . . . . .	1-7
	Options and Accessories . . . . .	1-7
	HOW TO USE THIS MANUAL . . . . .	1-8
<b>2</b>	<b>GETTING STARTED</b>	
	OVERVIEW . . . . .	2-1
	Introduction . . . . .	2-1
	What You Will Learn . . . . .	2-1
	What You Will Need . . . . .	2-2
	INITIAL SETUP . . . . .	2-2
	Hardware Setup . . . . .	2-3
	Front Panel Overview . . . . .	2-3
	BASIC MEASUREMENTS . . . . .	2-6
	MEASURING REAL SIGNALS . . . . .	2-8
	Setup Menu Parameters . . . . .	2-8
	Timing Menu Setup . . . . .	2-10

USING THE TRIGGER . . . . .	2-12
CHANGING THE DISPLAY . . . . .	2-14
OTHER TIMING SCREEN FEATURES . . . . .	2-15
Timing Cursors . . . . .	2-15
Voltage Cursors . . . . .	2-16
Trigger Threshold Field . . . . .	2-17
DIGITAL DISPLAY MODE . . . . .	2-18
TIME CHART MODE . . . . .	2-19
DISK FUNCTIONS . . . . .	2-19
MORE KEY . . . . .	2-20
Reference Waveforms . . . . .	2-21
Optional 800 MSample Probe . . . . .	2-22
<b>3 FRONT PANEL</b>	
OVERVIEW . . . . .	3-1
Introduction . . . . .	3-1
CRT DISPLAY . . . . .	3-2
KEYPAD . . . . .	3-3
Overview . . . . .	3-3
Cursor Movement Keys . . . . .	3-5
Next/Previous Keys . . . . .	3-5
Number/Units Keys . . . . .	3-5
2nd Key . . . . .	3-6
Start/Stop/CLear Keys . . . . .	3-6
Scroll Knob . . . . .	3-7
FLOPPY DISK DRIVE . . . . .	3-8
AC POWER SWITCH . . . . .	3-8
<b>4 TIMING SCREEN</b>	
OVERVIEW . . . . .	4-1
Introduction . . . . .	4-1
Screen Layout . . . . .	4-2
MENU FIELDS . . . . .	4-3
Vertical Resolution . . . . .	4-3
Trigger Selection . . . . .	4-4
Trigger Mode . . . . .	4-4
Trigger Event . . . . .	4-5
Trigger Filter Qualifier . . . . .	4-5
Trigger Filter Duration . . . . .	4-5
Status Window . . . . .	4-6
MEMORY SIZE BARS . . . . .	4-7
Horizontal Indicator Bars . . . . .	4-7
Vertical Indicator Bar . . . . .	4-8

TIME FIELDS . . . . .	4-8
Time Left Edge . . . . .	4-8
Time Per Division . . . . .	4-9
CHANNEL AND DISPLAY PARAMETERS . . . . .	4-10
Channel Selection . . . . .	4-11
Field Display . . . . .	4-12
Channel Volts Full-Scale . . . . .	4-12
Channel Volts Offset . . . . .	4-13
Channel Trigger Level . . . . .	4-13
Channel Volts Threshold . . . . .	4-14
Channel Trace Color . . . . .	4-15
Channel Text Label . . . . .	4-16
Channel Vertical Position . . . . .	4-18
WAVEFORM DISPLAY CHARACTERISTICS . . . . .	4-18
Number of Channels Displayed . . . . .	4-19
Persistence . . . . .	4-19
Sequence/Overlay . . . . .	4-19
Analog/Digital Display Mode . . . . .	4-20
CURSOR OPERATION . . . . .	4-20
Voltage Cursors . . . . .	4-20
Timing Cursors . . . . .	4-21
Cursor Measurements . . . . .	4-21

## 5 SETUP SCREEN

OVERVIEW . . . . .	5-1
Introduction . . . . .	5-1
Autosave Feature . . . . .	5-2
Setup and Timing Screen Interaction . . . . .	5-2
SCREEN LAYOUT . . . . .	5-2
MENU FIELDS . . . . .	5-2
Vertical Resolution . . . . .	5-2
Trigger Mode . . . . .	5-3
Trigger Event . . . . .	5-3
Trigger Filter Qualifier . . . . .	5-3
Trigger Filter Duration . . . . .	5-3
Status Window . . . . .	5-3
TIME FIELDS . . . . .	5-4
Time Left Edge . . . . .	5-4
Time Per Division . . . . .	5-4
CHANNEL AND DISPLAY PARAMETERS . . . . .	5-4
Channel Selection . . . . .	5-4
Channel Volts Full-Scale . . . . .	5-4
Channel Volts Offset . . . . .	5-5
Channel Volts Threshold . . . . .	5-5
Channel Trace Color . . . . .	5-6
Channel Text Label . . . . .	5-6

CHANNEL TRIGGER LEVEL . . . . .	5-7
GLOBAL CHANGES . . . . .	5-8
Start Channel Field . . . . .	5-9
End Channel Field . . . . .	5-9
Global Parameters Field . . . . .	5-9
Global Value Field . . . . .	5-9

## 6 DISK SCREEN

OVERVIEW . . . . .	6-1
Introduction . . . . .	6-1
Disk Screen Content . . . . .	6-2
PERFORMING DISK FUNCTIONS . . . . .	6-4
Delete A File . . . . .	6-4
Update the Directory . . . . .	6-4
Filter the Directory . . . . .	6-4
Load A File . . . . .	6-5
Load Default Setup File . . . . .	6-6
Saving Setups and Data . . . . .	6-6
Directory Sorting . . . . .	6-7
Format . . . . .	6-7
Drive Selection . . . . .	6-8
Disk Purchase and Formatting . . . . .	6-8

## 7 REAR PANEL

OVERVIEW . . . . .	7-1
Introduction . . . . .	7-1
INTENSITY CONTROL . . . . .	7-2
KEYBOARD CONNECTOR . . . . .	7-3
VIDEO OUTPUT CONNECTOR . . . . .	7-4
TRIGGER CONNECTORS . . . . .	7-5
Trigger input . . . . .	7-5
Trigger Enable Input . . . . .	7-5
Qualified Trigger Output . . . . .	7-5
System Trigger Output . . . . .	7-5
BUFFERED DATA OUTPUT CONNECTORS . . . . .	7-6
Signal Connections . . . . .	7-6
Using Buffered Output Signals . . . . .	7-6
OTHER CONNECTORS . . . . .	7-6
GPIB Connector . . . . .	7-6
RS-232 Serial Connector . . . . .	7-7
Parallel (Centronics) Connector . . . . .	7-7

COOLING FANS . . . . .	7-7
AC INPUT CONNECTOR . . . . .	7-7

## **8 SPECIAL OPERATING FEATURES**

OVERVIEW . . . . .	8-1
Introduction . . . . .	8-1
MORE KEY MENU . . . . .	8-1
I/O Setup Menu . . . . .	8-2
Probe Selection Menu . . . . .	8-3
Store Reference Memory Function . . . . .	8-3
Clear Reference Memory Function . . . . .	8-4
Logic Levels Menu . . . . .	8-4
Logic Levels Description . . . . .	8-5
Vil and Vih Logic Transition . . . . .	8-5
Stop Conditions Menu . . . . .	8-6
TIMECHART DISPLAY . . . . .	8-7
TIMECHART BUS DISPLAY . . . . .	8-7
HARD COPY OUTPUT . . . . .	8-9
FILE Selection . . . . .	8-9
RS-232 Port Selection . . . . .	8-9
RS-232 Parameters . . . . .	8-10
Parallel Port Selection . . . . .	8-11
GPIB Parameters . . . . .	8-11
PRINT FUNCTION . . . . .	8-11
Print Screen Contents to Printer . . . . .	8-11
Print Screen Contents to File . . . . .	8-12
Print Procedure . . . . .	8-12
Printing Files From External PC . . . . .	8-12

## **9 OPTIONS AND ACCESSORIES**

OVERVIEW . . . . .	9-1
Introduction . . . . .	9-1
800 MSAMPLE PROBE . . . . .	9-1
Applications . . . . .	9-2
Theory of Operation . . . . .	9-3
Probe Setup . . . . .	9-4
Menu Setup . . . . .	9-5
Optimizing the Display . . . . .	9-6
800 MSample Probe Specifications . . . . .	9-8
INTERNAL HARD DISK . . . . .	9-9
EXTERNAL KEYBOARD . . . . .	9-9
GPIB CONTROL . . . . .	9-10

## 10 GPIB OPTION

OVERVIEW . . . . .	10-1
Introduction . . . . .	10-1
GPIB OPERATION . . . . .	10-1
GPIB CABLE CONNECTIONS . . . . .	10-1
GPIB STARTUP . . . . .	10-2
REMOTE/LOCAL OPERATION . . . . .	10-3
Remote Mode . . . . .	10-3
Local Mode . . . . .	10-3
COMMUNICATION PROTOCOL . . . . .	10-3
Message Syntax . . . . .	10-4
Special Characters used in Syntax . . . . .	10-4
Combining Multiple Message Units . . . . .	10-5
Compound Message Headers . . . . .	10-5
Assign Value for Range of Elements . . . . .	10-6
USER REFERENCE DATA . . . . .	10-6
COMMON COMMANDS . . . . .	10-6
General . . . . .	10-6
Command Names . . . . .	10-6
COMMON COMMANDS FORMAT . . . . .	10-7
DEVICE SPECIFIC MESSAGES . . . . .	10-9
General . . . . .	10-9
Functional Elements . . . . .	10-9
DISPLAY SETUP MESSAGES . . . . .	10-11
General . . . . .	10-11
DISPLAY SETUP COMMANDS FORMAT . . . . .	10-12
HARDWARE SETUP MESSAGES . . . . .	10-20
General . . . . .	10-20
HARDWARE SETUP COMMANDS FORMAT . . . . .	10-21
DATA-RELATED MESSAGES . . . . .	10-26
General . . . . .	10-26
DATA-RELATED COMMANDS FORMAT . . . . .	10-26
CHANNEL SAMPLE DATA FORMAT . . . . .	10-28
Scope Mode, Low Resolution . . . . .	10-29
Scope Mode, High Resolution . . . . .	10-29
ANALYZER CONTROL FUNCTIONS . . . . .	10-29
General . . . . .	10-29
ANALYZER CONTROL COMMANDS FORMAT . . . . .	10-30
DEVICE STATUS REPORTING . . . . .	10-31
General . . . . .	10-31
Status Byte Register . . . . .	10-31
Service Request Enable Register . . . . .	10-32

Standard Event Status Register . . . . .	10-32
SYNCHRONIZATION TECHNIQUES . . . . .	10-33
Query/Readback . . . . .	10-33
Operation Complete . . . . .	10-33
INDEX OF COMMANDS . . . . .	10-34
GPIB COMMON COMMANDS . . . . .	10-34
DISPLAY SETUP COMMANDS . . . . .	10-35
HARDWARE SETUP COMMANDS . . . . .	10-36
DATA-RELATED COMMANDS . . . . .	10-36
ANALYZER CONTROL COMMANDS . . . . .	10-36

**APPENDICES**

<b>A K1600 SPECIFICATIONS . . . . .</b>	<b>A-1</b>
ACQUISITION . . . . .	A-1
TRIGGERING . . . . .	A-1
DISPLAY . . . . .	A-2
PROBES . . . . .	A-2
I/O INTERFACE . . . . .	A-2
STORAGE . . . . .	A-3
OPTIONS . . . . .	A-3
MECHANICAL . . . . .	A-4

<b>INDEX . . . . .</b>	<b>I-1</b>
------------------------	------------



# ILLUSTRATIONS

1-1	Typical Analog Timing Screen Display . . . . .	1-2
1-2	Setup Menu Display . . . . .	1-6
2-1	K1600 Rear Panel Details . . . . .	2-3
2-2	K1600 Front Panel Details . . . . .	2-4
2-3	Power-up Timing Display . . . . .	2-6
2-4	Help Display . . . . .	2-7
2-5	Setup Menu Display . . . . .	2-9
2-6	Auto-mode Display . . . . .	2-11
2-7	Single-mode Display . . . . .	2-12
2-8	Normal-mode Display . . . . .	2-13
2-9	Overlaid-mode Display . . . . .	2-14
2-10	Timing Cursor Positioning . . . . .	2-16
2-11	Voltage Cursor Positioning . . . . .	2-17
2-12	Digital-display Mode . . . . .	2-18
2-13	Time-chart Mode . . . . .	2-19
2-14	Disk Functions Menu . . . . .	2-20
2-15	More Options Menu . . . . .	2-21
3-1	Front Panel Components . . . . .	3-2
3-2	Analog Timing Display . . . . .	3-3
3-3	Keypad Details . . . . .	3-4
4-1	Timing Display and Setup Parameters . . . . .	4-2
4-2	Timing Display, TRIG=NORMAL Selected . . . . .	4-4
4-3	Timing Display, Memory Size Bars RCD and DSPL . . . . .	4-7
4-4	Horizontal Indicator Bars . . . . .	4-8
4-5	Vertical Indicator Bar . . . . .	4-8
4-6	Trigger Event Displacement by Time Left Edge . . . . .	4-9
4-7	Timing Display, Channels 01-08 Parameters . . . . .	4-11
4-8	Timing Display with Volts Offset (Vos) . . . . .	4-13
4-9	Timing Display with T1 Value for Trigger . . . . .	4-15
4-10	Timing Display Text Label, ADDR XX . . . . .	4-17
4-11	Timing Display, Waveform Selections . . . . .	4-18

4-12	Timing Display, Waveforms with Four Overlays . . . . .	4-20
4-13	Timing Display with Voltage (LM) and Timing (JK) Cursors . . . . .	4-22
5-1	Arrangement of Setup Screen . . . . .	5-1
5-2	Setup Display with Channel Volts Offset (Vos) Field . . . . .	5-5
5-3	Setup Display Text Label, ADDR 00-07 Selected . . . . .	5-7
5-4	Setup Display with Trigger Values X and L Specified . . . . .	5-8
5-5	Setup Display for Global Selections . . . . .	5-11
6-1	Disk Screen Arrangement . . . . .	6-2
7-1	K1600 Rear Panel Components . . . . .	7-2
8-1	More Key, Pop-Up Menu Screen . . . . .	8-2
8-2	More Key, I/O Setup Screen . . . . .	8-3
8-3	More Key, Logic Levels Menu . . . . .	8-4
8-4	More Key, Stop Conditions Menu . . . . .	8-6
8-5	Time Chart Bus Display . . . . .	8-8
8-6	Nine-pin to 25-pin Cable Connections Diagram . . . . .	8-11
9-1	800 MSample Probe Connections . . . . .	9-2
9-2	Demultiplex of Input to Obtain High-Resolution Output . . . . .	9-3
9-3	Channel Display Propagation for 800 MHz Mode . . . . .	9-4
9-4	Probe Selection for Pop-Up Menu . . . . .	9-5
9-5	Typical Display for 400 MS/sec Application . . . . .	9-6
9-6	Display Area Indicator . . . . .	9-7
9-7	High Speed Channel Combined with Three Normal Channels . . . . .	9-8
9-8	Keyboard Connector Details . . . . .	9-10
10-1	I/O Setup Screen . . . . .	10-2
10-2	GPIB Communications Protocol . . . . .	10-4
10-3	Status Byte and Service Request Enable Registers . . . . .	10-31
10-4	Standard Event Status and Enable Registers . . . . .	10-32

## TABLES

4-1	Range of Time-Left-Edge for Specified Time-Per-Division . . . . .	4-10
4-2	Variation in Color Selections for Internal/External Display . . . . .	4-16
7-1	Keypad Versus ASCII Keyboard Entry . . . . .	7-4
8-1	High and Low Logic Levels . . . . .	8-6
8-2	RS-232 Parameter Selections . . . . .	8-10

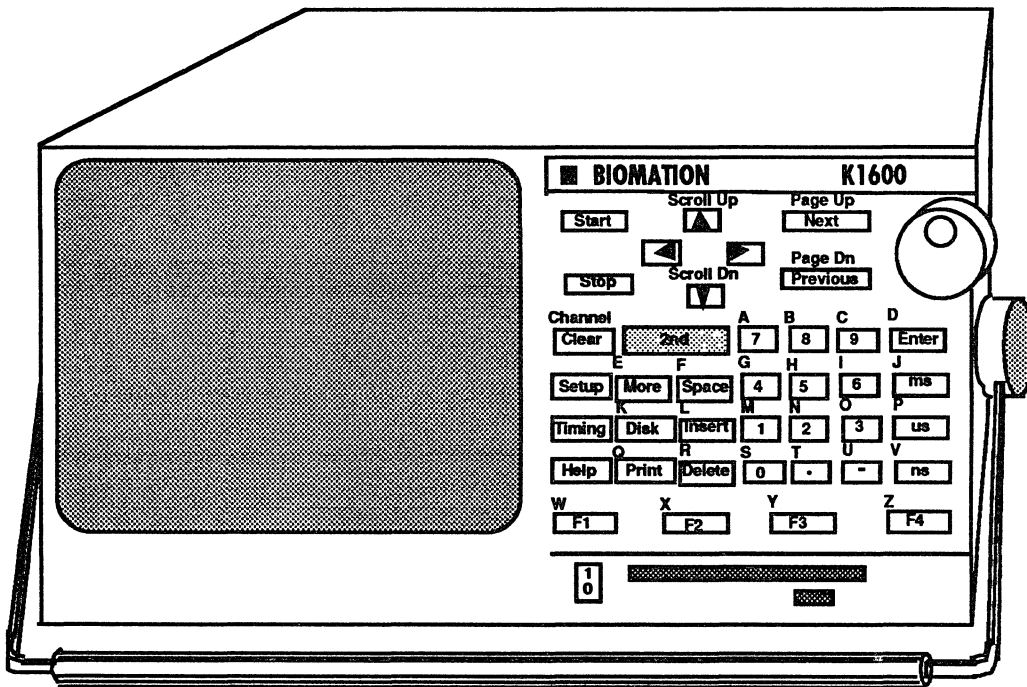

**K1600 Logic Waveform Analyzer**

## ***Chapter 1***

# **INTRODUCTION**

---

## **OVERVIEW**

### **Introduction**

The model K1600 Logic Waveform Analyzer combines the best features of a fast digital storage oscilloscope (DSO) with a high-speed logic analyzer to provide both analog and digital signal recording in a single instrument. A single set of probes connects to the target system and a single set of menus is used for setup, greatly reducing the time required to capture both analog and digital signals. Single probing allows you to obtain results faster than ever before possible.

The model K1600 records waveforms in analog. A single keystroke allows you to change displayed data from analog to digital. When traces are overlaid, the digital display provides a time chart or bus display along with a hexadecimal state readout on the bus.

Figure 1-1 shows an example of the analog Timing Screen display and Menu.

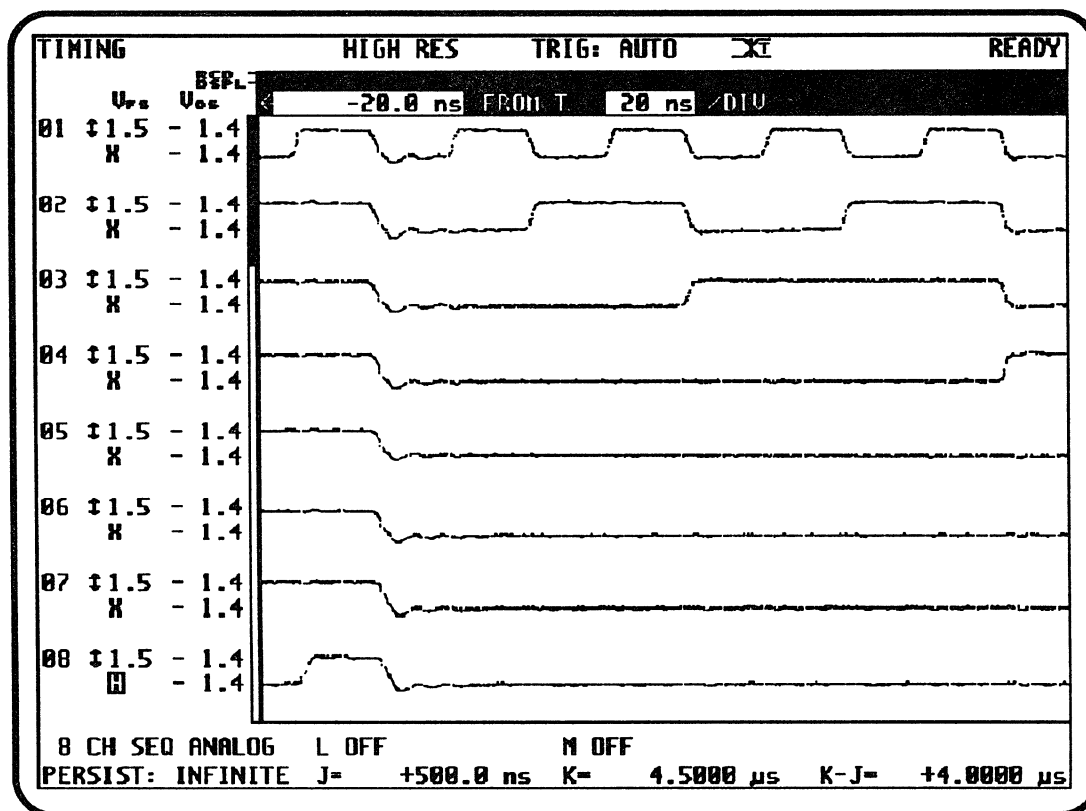

Figure 1-1. Typical Analog Timing Screen Display

You select all functions from menus by using the built-in keypad. Once a setup is complete, you may save it to disk on the built-in 3.5" floppy disk drive and recall it for use at a later time. This reduces setup time to a few seconds for often-used setups. An optional internal hard disk is available if you desire more disk storage.

The K1600 also has an "Autosave" feature. This feature consists of a nonvolatile SCRAM memory which automatically stores the last setup parameters when power is removed. The setup is restored at the next power up.

An optional IEEE-488 interface provides full automatic-test-equipment (ATE) capability, allowing you to control the model K1600 remotely by a GPIB host controller. This makes the unit well-suited for production or other automatic testing where you desire "hands-off" operation.

## Benchtop Applications

You will find many uses for the model K1600 in design verification and debugging: Designers can measure setup and hold times on many signals simultaneously; look for termination, ringing, and overshoot problems; and check rise and fall times. In addition, they can monitor timing signal fidelity on computer buses and ensure timing alignment and signal fidelity at the fixture in automatic-test-equipment systems.

Technicians will appreciate the ability to view signals in either analog or digital mode from a single set of probes connected to the system under test. With both modes in a single instrument the setup time is greatly reduced and the operation is simplified because you can use the same menu setups for both modes. With 16 channels in the instrument, it is seldom necessary to move probes as the typical oscilloscope would require.

Ease of use was a high priority in the Logic Waveform Analyzer design. This is an important feature in labs and workstations where technicians and engineers share common equipment. Setup and operation usually require only two menus, the Timing Menu and the Setup Menu. Each menu displays setup fields which set typical parameters. You simply move the cursor to the field of interest and enter the desired value for that parameter. Each field provides a unique "help" display describing the field and the range of values which you may enter.

The waveform display is extremely flexible; you may display any of the active channels on the CRT in any location. You can display up to 16 channels at one time. The waveform display scrolls up and down for easy viewing. One pair of horizontal cursors provides fast voltage-amplitude measurement of any displayed waveform, while another pair of vertical cursors provides accurate time-displacement measurements between any pair of points on the display.

## **ATE Applications**

The model K1600 Logic Waveform Analyzer is well-suited to ATE applications running under the control of a GPIB Host Controller. In these applications, you can make both digital measurements (using the digital mode) and analog measurements (using the analog mode) with a single connection to the target system. Before the Logic Waveform Analyzer became available, these tests required two separate instruments, two complete setups, and two GPIB control programs; now you can combine them into one.

As a multi-channel instrument, the model K1600 Logic Waveform Analyzer can provide up to 16 channels of analog recording with 350 MHz bandwidth, fast enough for TTL/CMOS and ECL applications. This could replace four to eight DSOs recording two to four channels each, an important saving in cost, setup complexity, and programming time.

ATE operation is straightforward and duplicates the features found in front-panel keypad operation. Duplicate menu setup with a series of ASCII string commands used to program the same fields you programmed from the front-panel keypad. Once you store data in memory, you may transfer it to the GPIB host controller for analysis or other use.

## MAIN FEATURES

### Analog Features

The model K1600 Logic Waveform Analyzer operates in a performance range which is well-suited to today's high-speed circuits, particularly TTL/CMOS and ECL circuits. These circuits require accurate recording of rise- and fall-times as well as voltage levels, and the model K1600 provides this accuracy. Performance features in the analog mode include the following:

- 350 MHz input bandwidth
- 50 ps minimum time resolution in repetitive sampling mode
- 800 Msample/second sampling in single event mode with optional 800 MSample Probe
- 50 k $\Omega$ , 2 pF input impedance at each probe tip
- 4-bit resolution in single-event recording mode
- 6-bit resolution in repetitive sampling mode
- 1.0 V to 10.0 V full-scale resolution
- 1000 sample memory length

### Digital Features

- Single keystroke conversion
- Time chart display
- Bus display

### Triggering Features

The model K1600 Logic Waveform Analyzer provides single-level triggering across all installed channels, and includes six modes of operation for maximum flexibility. You may set up the trigger on the Timing Menu for displayed channels, or on the Setup Menu for all channels.

Trigger features include the following:

- Combinational triggering across all channels
- External trigger ANDed with data channel trigger
- Time duration trigger qualification (four modes)
- Qualified trigger output signals on rear panel

## Menu and Display Features

The model K1600 Logic Waveform Analyzer is completely menu-driven, using two primary menus to perform all setup operations. The most-often used setup parameters are accessible from the Timing Screen, thereby making it easy to make changes and immediately observe their effect on the signals displayed. Other parameters are entered on the Setup Menu, which is a full-page menu that includes global setup fields and shows all trigger bits on one screen.

The Timing Screen and Menu provides the following features:

- Display of up to 16 channels in any position
- Overlay up to 16 channels for precise signal comparison
- Analog and digital time chart display modes
- Time and voltage cursors for easy measurement
- Infinite persistence display for long-term acquisition
- Minimum persistence display for normal acquisition
- All important setup parameters may be changed from this menu

The Setup Menu (Figure 1-2) provides the following features:

- Display and selection of all trigger bits on one screen
- Global setup fields for entering values on a group of channels
- Selection of external trigger bit level
- Duplicate display of all setup values from Timing Screen and Menu

An example of the Setup Menu is shown in Figure 1-2.



SETUP		HIGH RES	TRIG: AUTO	<input checked="" type="checkbox"/>	READY
TIMEBASE:			GLOBAL CHANGES:		
20 ns / DIV -20.0 ns FROM T			SET CHANNEL 01 TO 16 Uthresh = - 1.4		
CHANNEL PARAMETERS:				TRIGGER:	
Chn1	Vfs	Vos	Uth	Color	Text
01	1.5	- 1.4	- 1.4	-	
02	1.5	- 1.4	- 1.4		
03	1.5	- 1.4	- 1.4		
04	1.5	- 1.4	- 1.4		
05	1.5	- 1.4	- 1.4		
06	1.5	- 1.4	- 1.4		
07	1.5	- 1.4	- 1.4		
08	1.5	- 1.4	- 1.4		
09	1.5	- 1.4	- 1.4		
10	1.5	- 1.4	- 1.4		
11	1.5	- 1.4	- 1.4		
12	1.5	- 1.4	- 1.4		
13	1.5	- 1.4	- 1.4		
14	1.5	- 1.4	- 1.4		
15	1.5	- 1.4	- 1.4		
16	1.5	- 1.4	- 1.4		
				EXT X	
				01 X	
				02 X	
				03 X	
				04 X	
				05 X	
				06 X	
				07 X	
				08 <input checked="" type="checkbox"/>	
				09 X	
				10 X	
				11 X	
				12 X	
				13 X	
				14 X	
				15 X	
				16 X	

Figure 1-2. Setup Menu Display

The Disk Screen provides access to the built-in floppy disk drive and the optional hard disk drive. From this screen, you can save and recall often-used setups, reducing the setup time to a few seconds. This screen also provides a sorted directory of all files on the floppy or hard disk, as well as other utility functions.

The I/O Menu displays parameters for the RS-232 output connector and allows you to change parameters as needed to match the printer used for hardcopy printing.

The Probe Selection Menu allows you to select standard probes or the optional 800 MSample Probe accessory for each group of active channels.

The Logic Levels Menu allows you to select high and low logic threshold values for data displayed digitally.

The Stop Conditions Menu displays the Pass Count and Elapsed Time for recorded data and allows you to select a Pass Limit and Time Limit for the next recording.

## Input Probes

All input probes are of a passive-tip design which provides in excess of 350 MHz analog bandwidth. Data Input Probes come with eight input channels.

Each channel has a slim rectangular housing at the end of a coaxial cable which contains passive components. This tip connects to the target system by means of two receptacles for 0.025" pins, on 0.100" spacing. Adapters and grabbers are available for connection when 0.025" pins are not available.

The eight coaxial cables are bundled together in woven nylon mesh to reduce excessive wire clutter at the target system, but you can pull the mesh away from the probe tips to provide connection to widely-spaced points in the target system.

Electrical specifications for all probes are 50 k $\Omega$  and 2 pF.

## Menu Setup and Data Storage

You may use the built-in 3.5" floppy disk drive and the optional internal hard disk drive to store menu setups and recorded data. Use the Disk Screen to control all disk functions, making setup and recall very easy. This screen provides a filtered, sorted directory of all stored files, allowing easy access to these files.

You may also use this screen to delete unused files and other "housekeeping" chores, such as formatting blank disks for use with the unit.

## Other Features

The unit provides a VGA monitor connector on the rear panel to allow presenting the display on either the internal built-in monitor or an external monitor. This may be useful in situations where a remote display is more convenient than the display on the main-frame unit, or where large groups of people need to see the display at one time.

The rear panel also provides an external ASCII keyboard connector to allow simultaneous use of an AT-type computer keyboard along with the built-in keypad. While not required, the external keyboard is convenient when you use many alphanumeric labels for waveform labels or when you plan extensive disk functions. It is also useful if you use the Logic Waveform Analyzer with an external VGA monitor, as it frees you from being near the system.

The rear panel provides many signals of use to the test engineer in complex test applications. All inputs (Data and External Trigger) are buffered and provided as ECL-level signals output on the rear panel. You may use these signals for other purposes (additional triggering resources, for example). In addition, the Analyzer provides two TTL-level trigger outputs and TTL-level enable and trigger inputs.

## Options and Accessories

Several options and accessories described in Chapter 9 are available which make the Logic Waveform Analyzer more useful and convenient to use. Among these are a high-speed, single-shot, input probe, an internal hard disk for greater disk storage capacity, and the external monitor.

- The optional 800 MSample Probe provides single-shot sample rates up to 800 Msamples/sec on one channel or 400 Msamples/sec on two channels. The probe consists of a small box with two probe tips and two interface cables. One cable contains a connector which mates to the rear panel Channel Input Connector. The other cable plugs into the rear panel to receive power and control signals. Up to two pods can be used with a K1600.
- Use the 800 MSample Probe when you require high resolution on signals which are not repetitive. It is also useful in situations where the trigger is repetitive, but you need to capture an infrequent anomaly at a high sample rate.
- The optional internal hard disk provides 40 Mbytes of storage and increased speed when saving and recalling menu setups and recorded data. The optional hard disk usually is factory-installed and configured and may be ordered when the Logic Waveform Analyzer is purchased. You may also order it at a later date and installed it yourself.
- The optional external ASCII keyboard plugs into the back panel and provides full alphanumeric capability for ease of entry for waveform labels and disk filenames. In addition, the external keyboard allows remote operation with an external VGA color monitor.
- An optional GPIB Interface allows complete control of the K1600 Logic Waveform Analyzer from a GPIB host controller at the user's site. This option is often used in ATE applications where the user desires to automate several tests under control of a user-written control program.

## HOW TO USE THIS MANUAL

Chapter 2 of this manual provides an easy-to-follow Tutorial on the model K1600 Logic Waveform Analyzer. By going through this tutorial step by step, you will quickly learn the basics of operation and many of the advanced features. The few hours spent on this tutorial will provide an effective overview of the product and show many of the features you will need in using the unit.

This manual can also provide an overview of the Logic Waveform Analyzer without having the hardware present. By skimming each chapter, you will learn about the basic and advanced features and their use. The pictures and diagrams further clarify the menu and display screens of the K1600 and provide a foundation for their later use.

During instrument use, use this manual as a convenient reference for everything about the unit. The Table of Contents and the Index provide the exact location of any topic of interest, taking you directly to the section which applies your present application.

Biomation welcomes your comments on the Logic Waveform Analyzer and on this manual. If you find an area not adequately covered in the manual or a feature you feel would make this product better, please contact our Applications Department at the telephone number listed in the Preface. Your input is always appreciated.

## **Chapter 2**

# **GETTING STARTED**

---

## **OVERVIEW**

### **Introduction**

This chapter provides a hands-on tutorial of the Logic Waveform Analyzer for new users. The only piece of equipment required is the model K1600 instrument and one data input probe set. Nine ECL-level output signals and one ground signal are available on the rear panel and will provide real input signals for this tutorial. By using real signals, the user gains confidence in his abilities as he learns about each field on the menus and data display. If the adage “the best way to learn something is by doing” is true, then this tutorial should help make the Logic Waveform Analyzer easy to understand and use in actual applications.

As you go through this tutorial, it is a good idea to make notes of points that are not clear and to identify special features of the Logic Waveform Analyzer which might be useful in your application. The remainder of this manual can provide the reference material for areas you would like to explore in greater detail, or for points which are not fully described in this brief tutorial.

If you encounter a problem which the manual cannot resolve, please contact your Biomation distributor or sales representative for help. Also, feel free to call our Applications Department at our factory listed on the Preface page in front of this manual. Everyone benefits when you can use a piece of test equipment to its fullest capacity, so please call us if you have any questions about the K1600.

### **What You Will Learn**

This tutorial is arranged in a logical sequence, including the hardware set-up and the use of each menu and display screen to record and display data from a signal source. By completing the tutorial step by step, you will learn both the basic operation of the Logic Waveform Analyzer and cover many of the advanced features as well.

In addition, by completing this tutorial, you will become familiar with the instrument features and the organization of manual content. You will also learn how easy it is to set up the unit and start taking data, how to display the part of the data stream of interest, and how to set a simple trigger. As you progress, you will also learn to save your new menu setup to disk, and how to recall it from the disk. And you will develop a feeling

of confidence that you can use the Logic Waveform Analyzer any time for a wide variety of test applications.

### **What You Will Need**

To complete this tutorial, you will need a model K1600 Logic Waveform Analyzer and at least one input data probe set. The "Calibration" signals available on the rear of the model K1600 will provide a satisfactory test signal source for this tutorial. If you like, you may repeat this tutorial later with a more complex signal source, such as one from a digital word generator. The more complex the pattern, the more variety you can put into the tutorial and the more features you will be able to try out.

The screen pictures which follow were made using the ECL-level signals from the Calibration connector, but signals from other signal sources will produce similar results.

A minimum configuration of the Logic Waveform Analyzer is fine for this tutorial. This includes at least one Data Input Probe set. Neither the optional hard disk nor an external ASCII keyboard is required to complete the tutorial.

## **INITIAL SETUP**

Remove the K1600 instrument from its shipping container and check the packing list to verify the following items are present: (1) Model K1600 Instrument, (2) Two sets of Data Input Probes, and (3) AC line cord. Connect the AC line cord to the AC connector on the rear panel of the K1600 chassis (Figure 2-1) and to the facility AC power source.

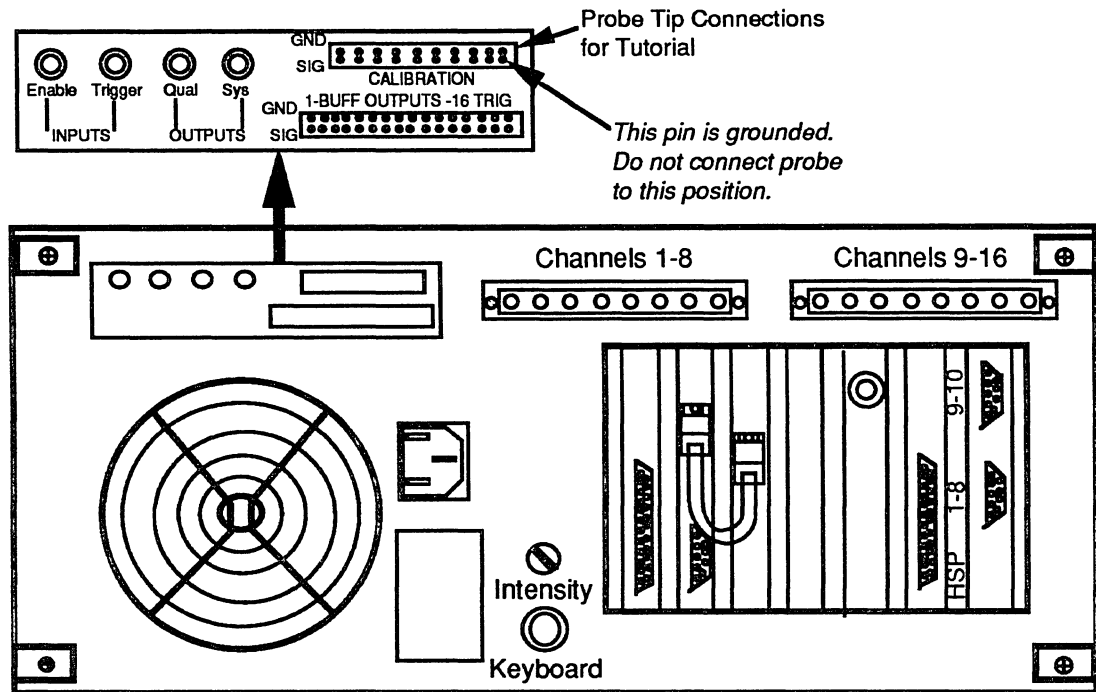

Figure 2-1. K1600 Rear Panel Details

## Hardware Setup

Start by connecting one or both Data Input Probe sets to the Channels Connectors on the rear panel. Do not over-tighten the screws; they only need to be snug. All Input Data Probes are identical and may be installed in any position.

Looking at the rear panel, the left probe set displays signals on channels 1 through 8, while the right probe set displays signals on channels 9 through 16. All probe tips are marked 1-8.

Connect Data Input Probe tips for channels 1-8 to the Calibration Connector, also on the rear panel (see Figure 2-1). Observe the polarity symbols on the Calibration Connector; the blue stripe on the probe tip identifies the signal side of the tip, while the opposite side is common or ground. Each probe must have its own ground connection.

**NOTE:** The blue stripe on each probe tip identifies the *signal* input while the white side of the probe is the *common* or ground lead. The signal input is *always* connected to the signal source, even though the signal may be negative (an ECL signal, for example).

## Front Panel Overview

You may perform all operations on the model K1600 Logic Waveform Analyzer from the keypad on the front panel. You may use an external ASCII keyboard if desired but

it is not needed, and should be avoided for this tutorial. Learning the operation of the front panel keys will be valuable for later use of the instrument.

AC power is applied and removed at the K1600 by operating the two-position, rocker contact switch located on the front panel. This switch is labeled **0** and **1** to indicate power off and on positions respectively. An audio beep signal sounds when you apply AC power. The instrument performs a series of self-test diagnostics and displays the Timing Screen when power up is complete.

Three logical groups divide the front panel (Figure 2-2): the CRT display, the Keypad area, and the Floppy disk drive.

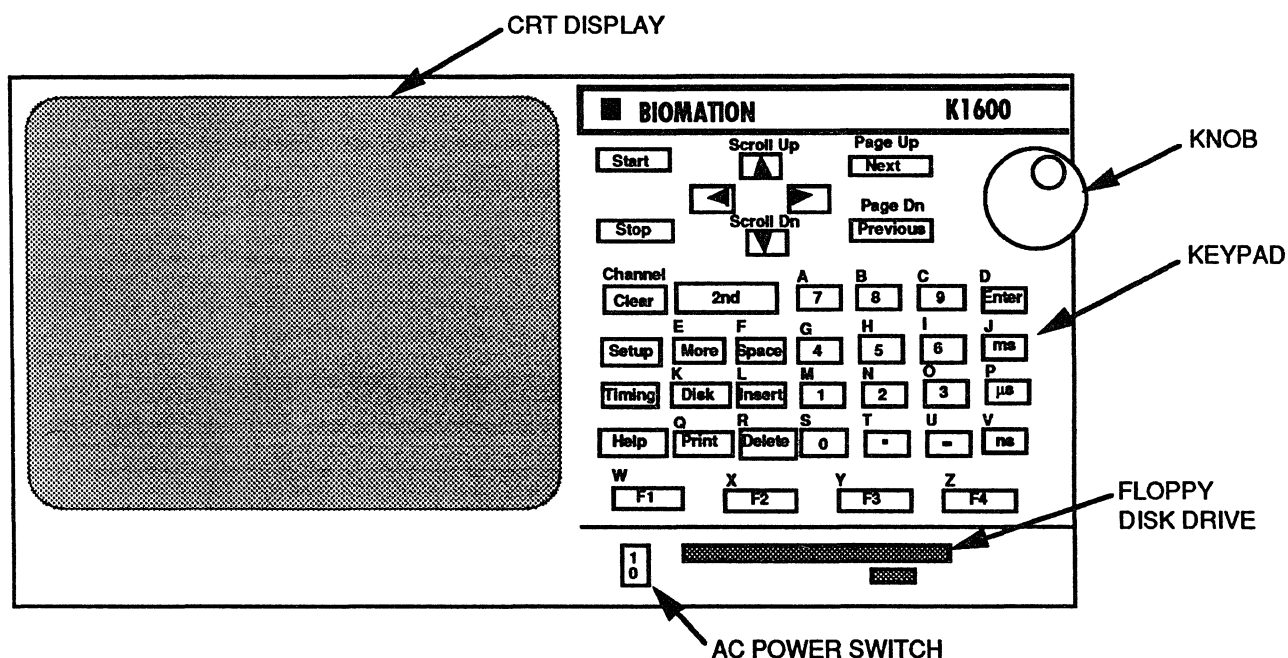

Figure 2-2. K1600 Front Panel Details

The keypad provides control of all menu fields and all start/stop/clear screen functions. The front panel groups the keys into five functional areas as follows: (1) cursor movement keys, (2) **Next/Previous** keys, (3) number/units keys, (4) function keys, and (5) **Start/Stop/Clear** keys.

Use the cursor movement keys to move the cursor around the screen. The arrow markings correspond to their cursor movement direction. These keys are repeating—holding down the key will move the cursor continuously in the same direction.

Use the **Next** and **Previous** keys to increment or decrement the displayed value in the field at the cursor location. If the field contains a text selection, these keys will roll through all available choices at this location.

The **Knob** duplicates the action of the **Next** and **Previous** keys, and you may use it to increment and decrement the displayed value in the field at the cursor location. The

knob is particularly useful for making large changes in the displayed value, such as moving the timing and voltage cursors to a new location.

Use the number/units keys to enter numerical values and appropriate units into the selected cursor field.

The **Start/Stop/Clear** keys perform their respective functions. The **Start** key arms the unit and begins data recording. The **Stop** key halts data recording and “freezes” the display on the screen. The **Clear** key clears all data from the display.

Use the blue **2nd** key to give most keys a second function. This almost doubles the number of key choices available on the front panel. When you press the **2nd** key, the message “2nd” appears in the upper-left-hand corner of the display, and indicates that the second-key function is active. Pressing a key with the 2nd message displayed will give the value displayed in blue above the pressed key. For example, pressing the **2nd** key and then pressing the **7** key will enter an “A” into the active cursor field. The **2nd** key does not lock and you must press it before each second function key.

The **Clear/Channel** key clears data from the display on the channel where the blinking cursor is located. This is a second-key function and you activate it by first pressing the blue **2nd** key, then the **Clear** key.

Use the **Page Up** and **Page Dn** keys to move the entire timing display up or down a “page” at a time. These keys are second-key functions and are particularly useful when the timing display is in the two- or four-channel mode.

Use the **Scroll Up** and **Scroll Dn** keys to scroll through the 32 available channel display positions, one position at a time. These keys are second-key functions.

The remaining second-key functions provide the entire alphabet. Used them for entering labels into the timing and setup displays or alphanumeric filenames for the Disk Functions Menu.

The **More** key brings up the More Options Menu, a sub-menu which allows you to access various functions for which there is not a dedicated key. These functions include store and clear reference memory, specifying the I/O parameters, and selection of the optional 800 MSample Probe Menu.

The **Help** key brings up a help message for the field on which you have the cursor placed.

The four function keys (**F1**, **F2**, **F3**, and **F4**) perform special functions as described later in this manual (for example, when using the Disk Functions Menu).

Chapter 3 explains all key functions greater detail. It presents a full description of the front-panel controls.



# BASIC MEASUREMENTS

Two important features, such as the wide-channel capability and extensive trigger combinations, separate the Logic Waveform Analyzer from digital storage oscilloscopes. This tutorial will illustrate both features.

Turn on the Logic Waveform Analyzer and wait for the system to boot and perform its internal diagnostic program. This takes about thirty seconds, and is complete when the unit displays the Timing Screen.

The model K1600 Logic Waveform Analyzer has an "Autosave" feature, which restores during power-up, all menu parameters from the last time the instrument was used. This time-saving feature sets the menus, setting them to the same values that were programmed the last time the instrument was used. Because of this feature, the initial screen on the unit you are using may be somewhat different from the pictures which follow. As you become familiar with the unit you will learn how to change menu parameters for your use. Figure 2-3 shows a typical power-up Timing Screen.

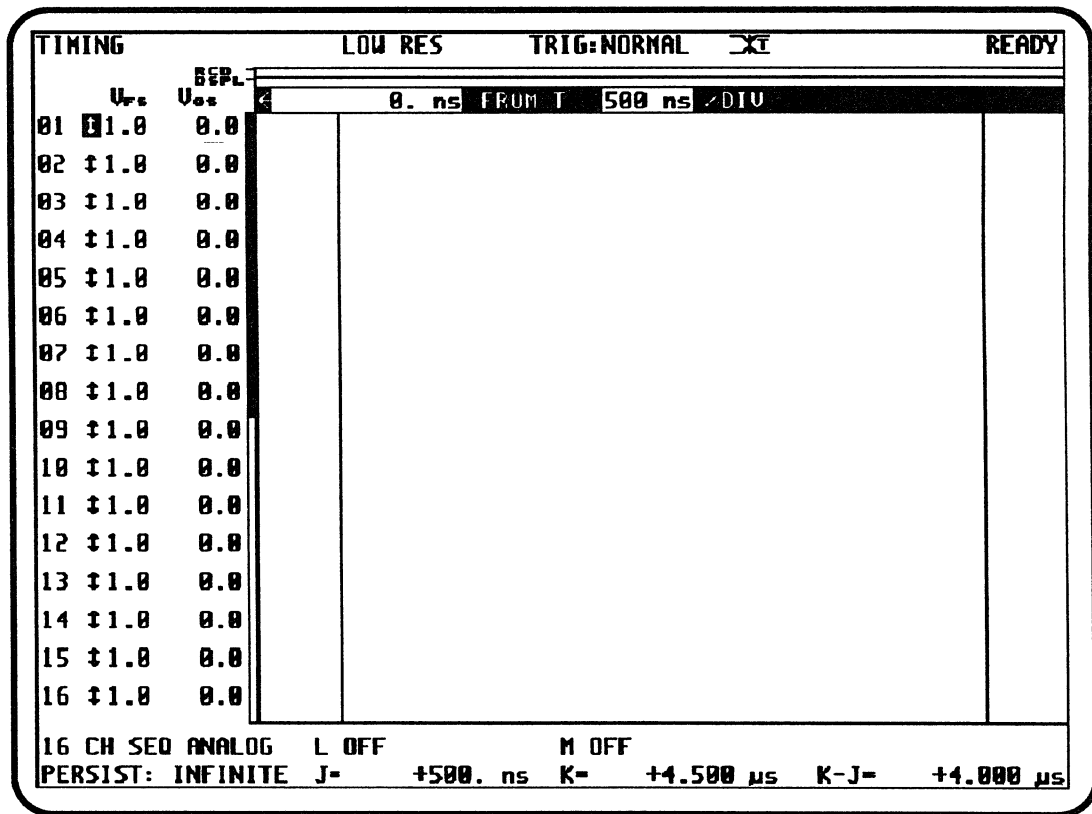

Figure 2-3. Power-up Timing Screen

Take a few minutes to become familiar with the front-panel keys of the unit. Each key has been described above and is clearly marked with its function (or functions, in the case of dual function keys). Refer back to the key description section if needed.

Try out the cursor control keys, using them to move the blinking cursor to each position on the screen. Use the **Next** and **Previous** keys to change the values at several cursor locations.

Try the **Help** key by pressing this key at several cursor locations. There is only one help message at each location, regardless of the value displayed in the location. Note that the help message provides the following information at each location:

- The name of the location or field
- The values which are allowed at the location
- A brief description of the function selected at the location
- The keys used to enter or change values at the location

An example of a Help Display is shown in Figure 2-4.

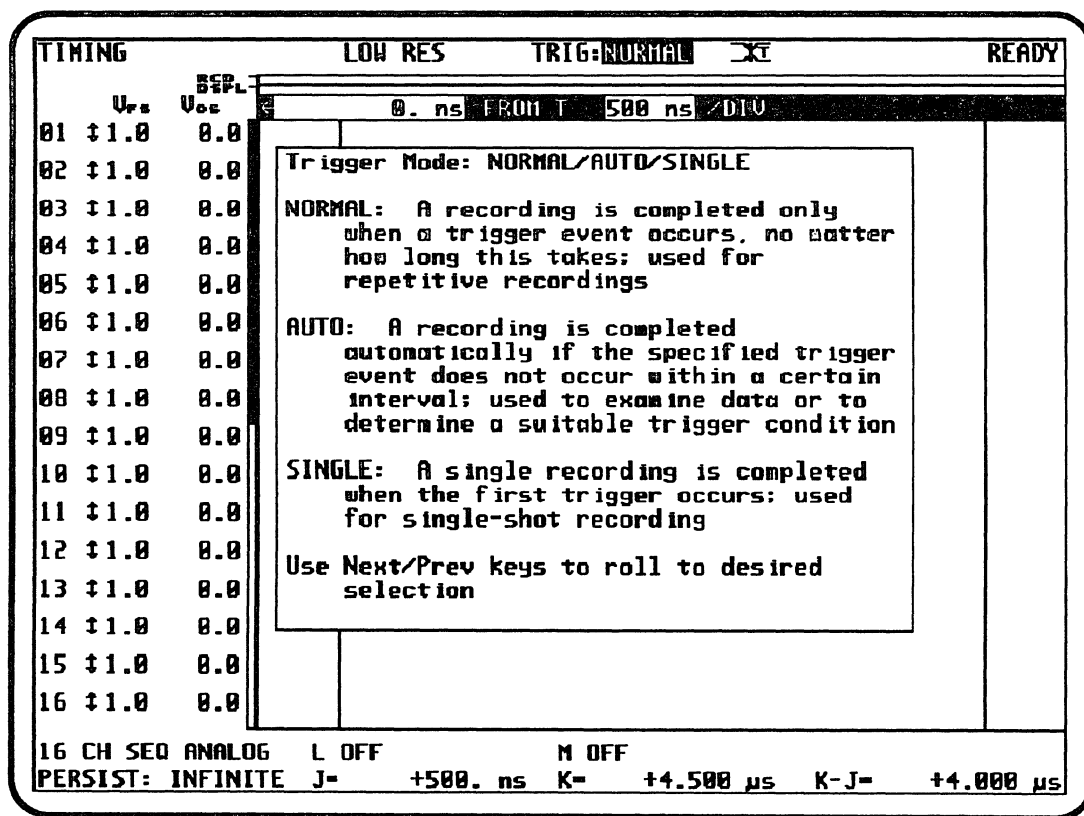

Figure 2-4. Help Display

Move the cursor to the Number of Channels Displayed field (lower-left corner of the screen) and roll the displayed value to 16 channels. If the channels are not displayed

individually (in sequence), move the cursor to the right and roll the value in the Sequence/Overlay field to `Sequence`. Move the cursor to the right again and select `Analog` in the Analog/Digital field. This will display 16 channels in sequence on the screen.

Now move the cursor to any field showing a double-ended vertical arrow, and use the **Next** key to scroll through the four available choices. These choices cause the selectable parameters to change as shown below:

- Volts Full-Scale and Volts Offset are displayed
- Trigger Bit (X, L, H) and Volts Threshold are displayed
- Trace Color and Text Label are displayed
- Vertical Position is displayed (overlaid mode only)

Change the display back to the Volts Full-Scale and Volts Offset selection.

Note that the double-ended arrow is visible only on the eight- and the 16-channel display. The two- and four-channel displays provide sufficient room for all values to be displayed at one time.

## MEASURING REAL SIGNALS

If the connection to the Calibration Connector has been made as described earlier, you are ready to set the menu parameters for ECL-level signals. This section will lead you through that setup.

### Setup Menu Parameters

The Setup Menu is usually the starting point for the initial Logic Waveform Analyzer setup. This menu shows all setup parameters on one screen and provides a “Global Setup” feature in which several (or all) channels may be set at the same time. You will use the Global Setup feature in this tutorial. Press the **Setup** key to display the Setup Menu.

In Figure 2-5 the Global Setup section is in the upper-right-hand portion of the screen.

SETUP		LOW RES	TRIG:NORMAL	<input checked="" type="checkbox"/>	READY		
TIMEBASE:		Press ENTER for global set.					
500 ns / DIV		SET CHANNEL 01 TO 16					
0. ns FROM T		Vglobal = ECL					
ECL 1.2 - 1.3 - 1.3							
CHANNEL PARAMETERS:		TRIGGER:					
Chnl	Vfs	Vos	Uth	Color	Text	EXT	X
01	1.0	0.0	0.0	█		01	X
02	1.0	0.0	0.0	█		02	X
03	1.0	0.0	0.0	█		03	X
04	1.0	0.0	0.0	█		04	X
05	1.0	0.0	0.0	█		05	X
06	1.0	0.0	0.0	█		06	X
07	1.0	0.0	0.0	█		07	X
08	1.0	0.0	0.0	█		08	X
09	1.0	0.0	0.0	█		09	X
10	1.0	0.0	0.0	█		10	X
11	1.0	0.0	0.0	█		11	X
12	1.0	0.0	0.0	█		12	X
13	1.0	0.0	0.0	█		13	X
14	1.0	0.0	0.0	█		14	X
15	1.0	0.0	0.0	█		15	X
16	1.0	0.0	0.0	█		16	X

Figure 2-5. Setup Menu Display

Move the blinking cursor to the SET CHANNEL field and enter channel 01. Repeat for the TO field and enter channel 16.

Now move the blinking cursor to the Global Parameters field (just below the SET CHANNEL fields) and roll this field to *vfs*, which stands for Volts Full-Scale. Move the cursor to the field at the right and enter 1.5 v. Press **Enter** again to execute the global setup values. Note that these steps set all 16 channels to 1.5 V full-scale.

Move the blinking cursor back to the *vfs* field and roll this field to *vthresh*, which stands for Volts Threshold. Move the cursor to the field at the right and enter -1.4 v. Press **Enter** to execute the global setup values. Note that these steps set all 16 channels to a trigger threshold value of -1.4 V.

Repeat the above steps for *voffset*, the Volts Offset value, and note the results. The Logic Waveform Analyzer is now set for the ECL-level signals available on the Calibration Connector.

The use of the Preset Global Setup feature will be described in a later section.

## Timing Menu Setup

The analog mode has two resolution modes of operation (low and high resolution) and three triggering modes (normal, auto, and single). The selection of these modes depends on the test application and the nature of the signals being measured. Here's a brief description of the modes listed above.

- **Low Resolution**—This mode uses a four-bit A/D and displays 16 vertical points on the waveform. It is often preferred for its fast screen update where maximum vertical resolution is not required.
- **High Resolution**—This mode uses repetitive recording to build a six-bit waveform. It displays 60 vertical points on the waveform. Use this mode when you require maximum vertical resolution. This mode requires a repetitive trigger event to produce a complete waveform.
- **Normal Trigger**—This trigger mode records data only when a trigger event occurs, regardless of how long the time period between trigger events. With low-repetition trigger events, this mode often requires several seconds or minutes to produce a complete waveform on the screen.
- **Auto Trigger**—This mode completes the recording automatically, even when the trigger event is not present. This mode is often used to examine data or to determine a suitable trigger condition for the normal trigger mode described above. With Auto Triggering, repetitive recordings are not aligned with each other. Also, this mode should be used to identify signal levels.
- **Single Trigger**—This mode takes a single recording at the first trigger event. Each time the **Start** key is pressed another recording is taken and displayed on the screen. This mode is used for single-shot recording or non-repetitive events. Only low resolution is supported with Single Trigger.

Press the **Timing** key to restore the Timing Screen.

Move the blinking cursor to the lower left hand corner of the Timing Screen and set the display to eight-channel, sequential, analog, infinite persistence.

Move the blinking cursor to the **TRIGGER** field and roll this field to **AUTO**. Press the **Start** key and note the display on the screen. The overlapping waveforms are the result of not using a trigger to record the waveform at the same point each time data is recorded.

An example of the Auto-mode Display is shown in Figure 2-6.

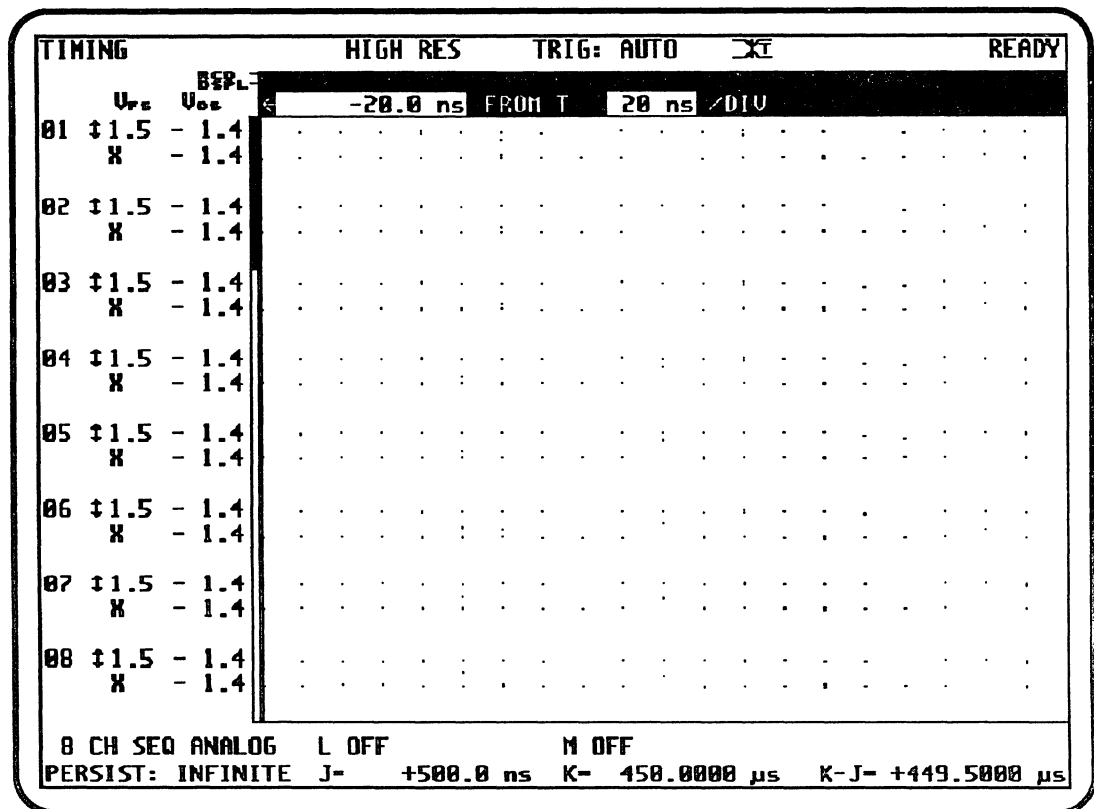

Figure 2-6. Auto-mode Display

There are two Clear functions in the Logic Waveform Analyzer. Both are accessed using the **Clear** key on the front panel. The **Clear** key erases all waveforms from the screen, leaving it blank for the next recording. The **Clear/Channel** key (2nd and **Clear** keys) erases only the waveform at the cursor location (if the cursor is not located on a displayed channel, this key has no effect).

If the unit is stopped (in the Ready mode), the **Clear/Channel** key acts as a toggle, allowing you to restore to the screen the data for that channel that was in memory when the unit was stopped.

Move the blinking cursor to channel 01 and press the **Clear/Channel** key (2nd and **Clear** keys); repeat for channel 02. Note that only the channel at the cursor location is erased. Now press the **Clear** key; note that all remaining channels are erased from the screen.

Move the blinking cursor back to channel 01 and press the **Clear/Channel** key again. Note that the data that was cleared from the screen is restored. Repeat for several other channels. This feature allows the user to recover data that was cleared accidentally by pressing the **Clear** or **Clear/Channel** keys.

# USING THE TRIGGER

The remaining two trigger modes require a trigger to be set. The trigger may be as simple as one bit specified H or L (logic level high or logic level low), or may include all active channels as well as the variable time filter described later.

The trigger may be set on either the Timing Screen or the Setup Menu. For this exercise, you will set the trigger on the Timing Screen. Move the blinking cursor to any of the double-ended fields next to the eight channel numbers. Press the **Next** key one time to display the trigger bit and trigger threshold voltage ( $V_{th}$ ) for each channel. Move the blinking cursor into the trigger field of channel 01 and use the **Next** key to change this field to H (logic level high).

Move the cursor to the Time Per Division field and enter a value of 100 ns. This field controls the resolution of the waveform on the screen, and is normally set to a value which shows individual signal characteristics clearly.

Move the blinking cursor back to the Trigger field. Roll the Trigger to SINGLE and press the **Start** key. Note that a series of points starts to define the waveform, but is not sufficient to define it accurately. Press the **Start** key several more times to fill in more of the waveform.

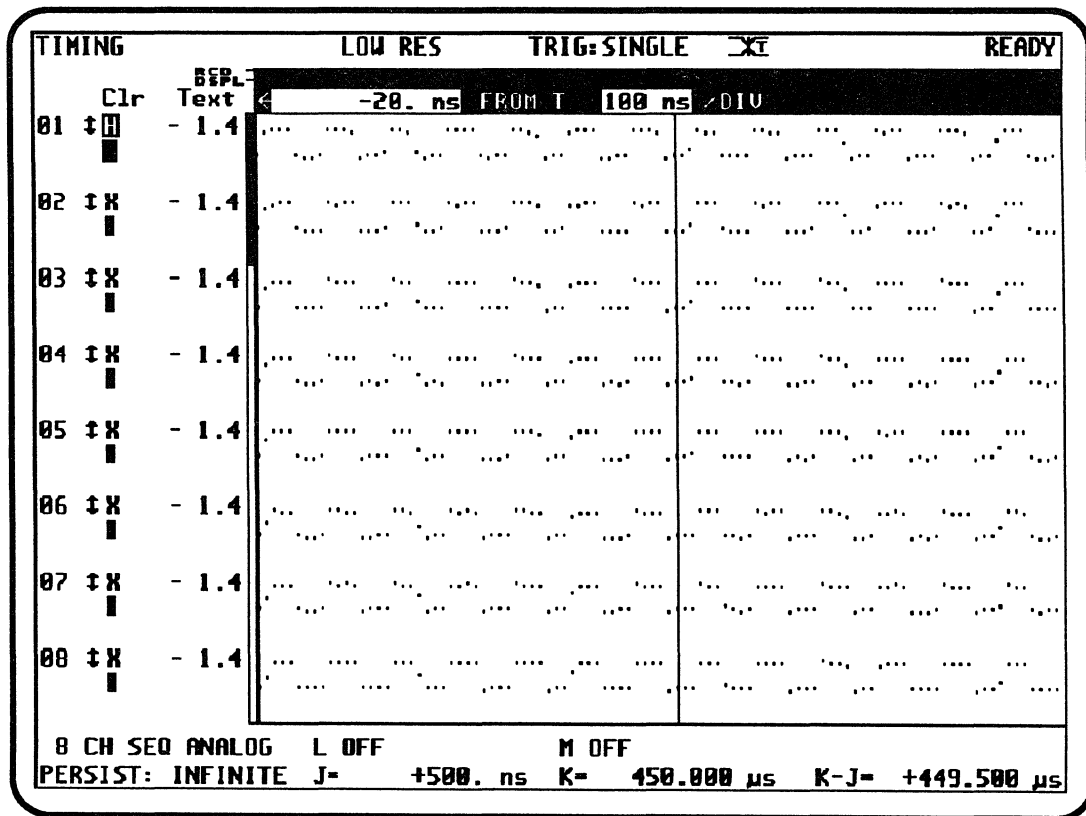

Figure 2-7. Single-mode Display

As explained above, the Single mode is used where the signal is non-repetitive and must be captured in one recording, but detail will be sacrificed because of the few points represented.

An example of the Single-mode display is shown in Figure 2-7.

Press the **Clear** key to clear the display.

Roll the Trigger to **NORMAL** and press the **Start** key again. Note the message "RUNNING" in the upper-right-hand corner of the display. This message shows the present status of the Logic Waveform Analyzer and provides useful information during data recording. For example, the message "TRIGGER ?" indicates that the specified trigger bit pattern is not present, or that the specified filter time requirement is not being met.

Look carefully at the waveform being produced on the screen. If the H bit set on channel 01 defines a unique part of the data stream, all the displayed signals will be clear and crisp. If one or more channels is recording a non-repetitive signal (with respect to the trigger bit specified), then these signals will overlap and will not be distinct. The example below shows a situation in which all channels are the same, so all are clear and distinct.

An example of the Normal-mode display is shown in Figure 2-8.

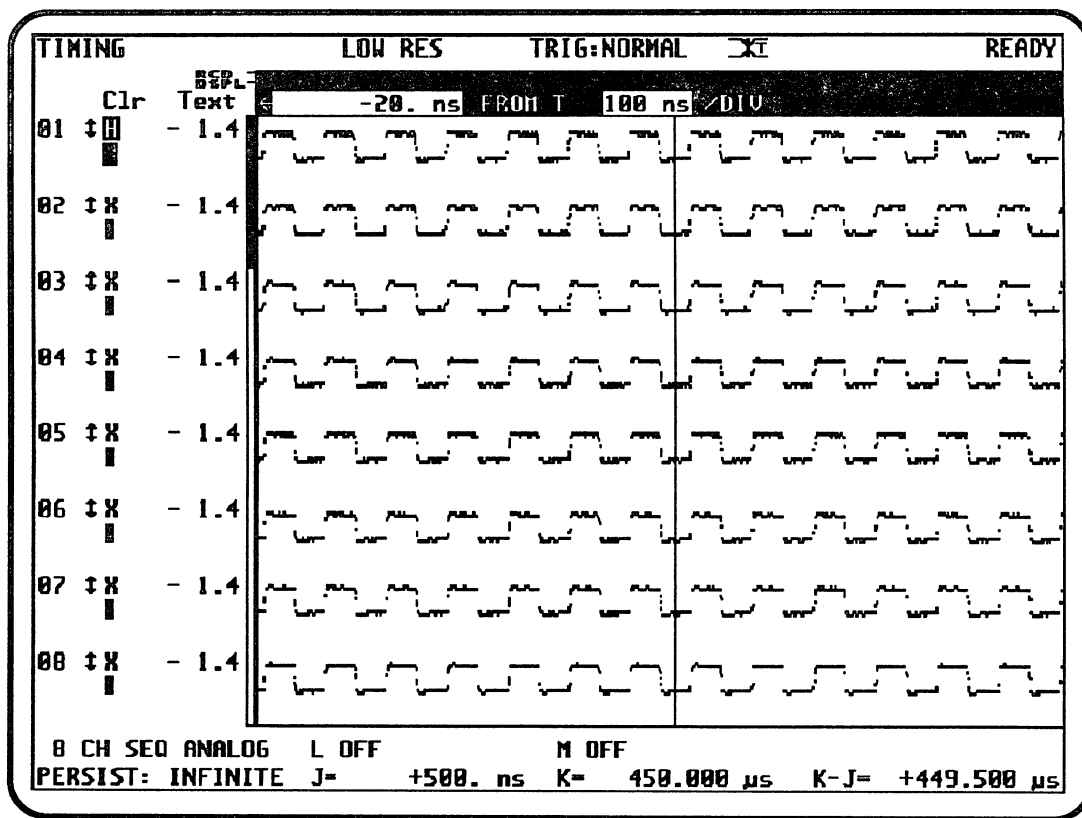

Figure 2-8. Normal-mode Display



Move the blinking cursor to the **LOW RES** field at the top of the screen, and roll this field to **HIGH RES**. Press the **Clear** key and note the difference between the waveform on the screen and the previous waveform recorded in the low resolution mode. The trade-off for this higher resolution is that the display takes approximately four times as long to create as it did in the low resolution mode.

Change the time per division field to **20 ns**, press the **Clear** key and note that the data is expanded on the display. A smaller time per division value results in higher timing resolution, but a smaller period of time is displayed on the screen.

## CHANGING THE DISPLAY

This is a good time to experiment with the waveform display characteristics. Move the blinking cursor to the Channels Displayed field. The screen can be used to display from two to 16 channels at one time; the number is selected in this field. Use the **Next** key to scroll through the available choices (16, 8, 4, and 2). Try each selection to see the appearance of the waveform and the detail provided at each selection.

An example of the Overlaid-mode display is shown in Figure 2-9.

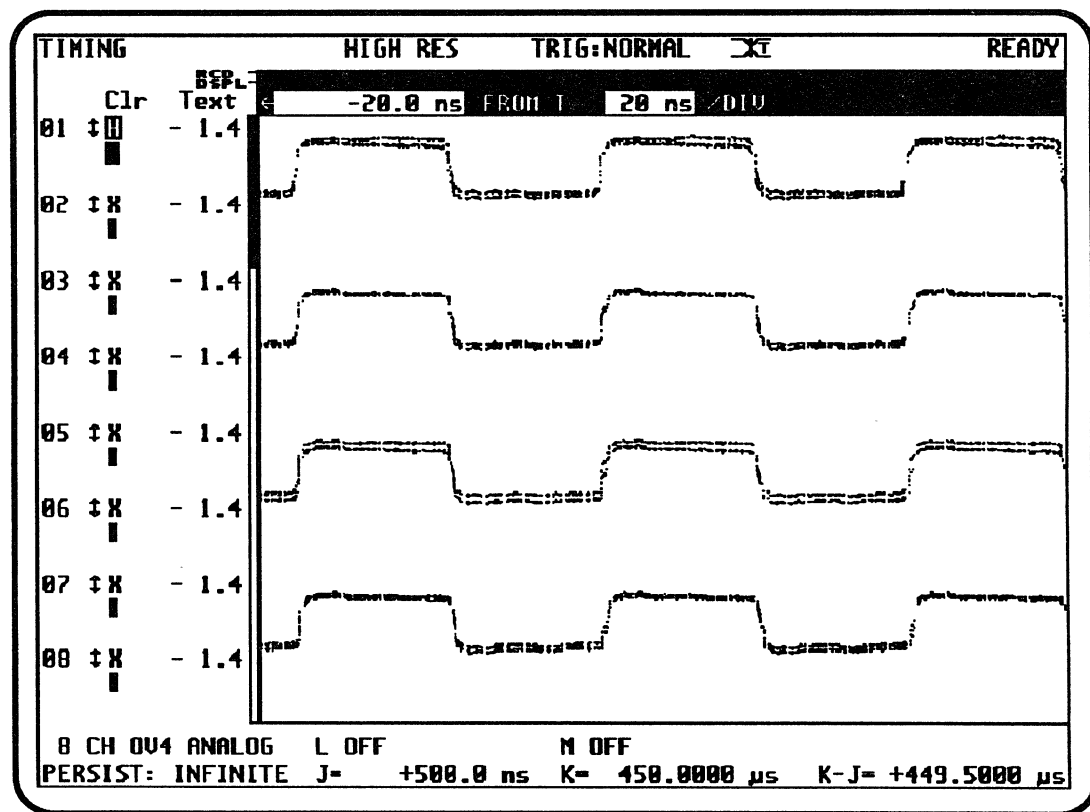

Figure 2-9. Overlaid-mode Display

Move the blinking cursor to the Sequence/Overlay field and use the **Next** key to roll through all available choices. Note that the overlaid displays can benefit from using different colors on each channel if an external VGA monitor is used. This will be described in greater detail later in this tutorial.

The Persistence field controls the time that individual waveform dots remain on the display. Values in this field are **MINIMUM** and **INFINITE**. Try the minimum persistence mode now and note the difference between **MINIMUM** and **INFINITE** modes.

## OTHER TIMING SCREEN FEATURES

### Timing Cursors

Move the blinking cursor to the J-timing cursor field and use the **Knob** or the **Next** and **Previous** keys to change the Timing Cursor. These cursor fields will also accept numerical values followed by a units key. The Timing Cursors are always active and you cannot turn them off, but you may move them off the display screen if you so desire.

Use these Timing Cursors to measure time values between points on the display. The display shows the  $\Delta$  time to the right of the two cursor fields in a field marked "K-J=". In actual use, it is best to keep the J cursor to the right of the K cursor, as this results in a positive value in the difference field.

You can make exact timing measurements more easily if you display only two or four channels, as this makes each waveform larger and easier to see. Change to the two-channel sequential mode and make a timing measurement on one of the waveforms.

The Figure 2-10 example shows the use of Timing Cursors.

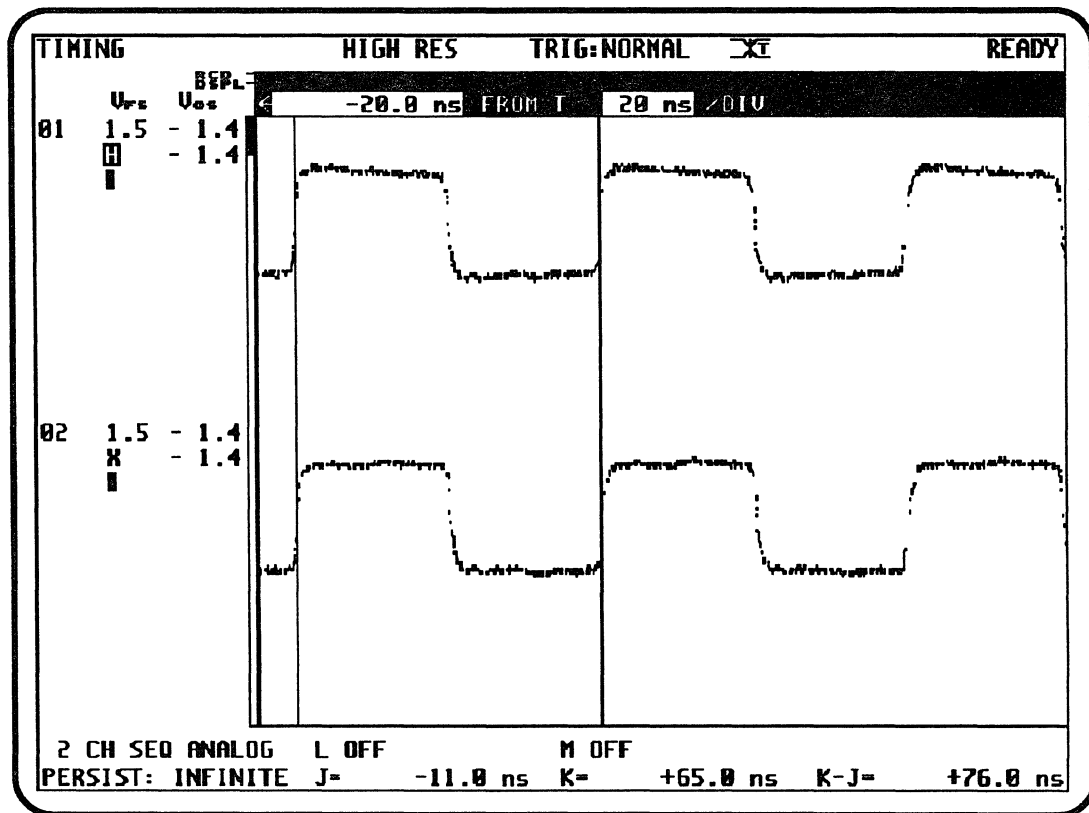

Figure 2-10. Timing Cursor Positioning

## Voltage Cursors

Move the blinking cursor to the L-voltage cursor field and roll the value to channel 01. Repeat for the M-voltage cursor. Note the single horizontal line at 0.000 V through the channel one waveform.

Move the blinking cursor to the L-voltage cursor value field and use the **Knob** or the **Next** and **Previous** keys to move the cursor throughout the vertical range of the waveform. Repeat for the M-voltage cursor.

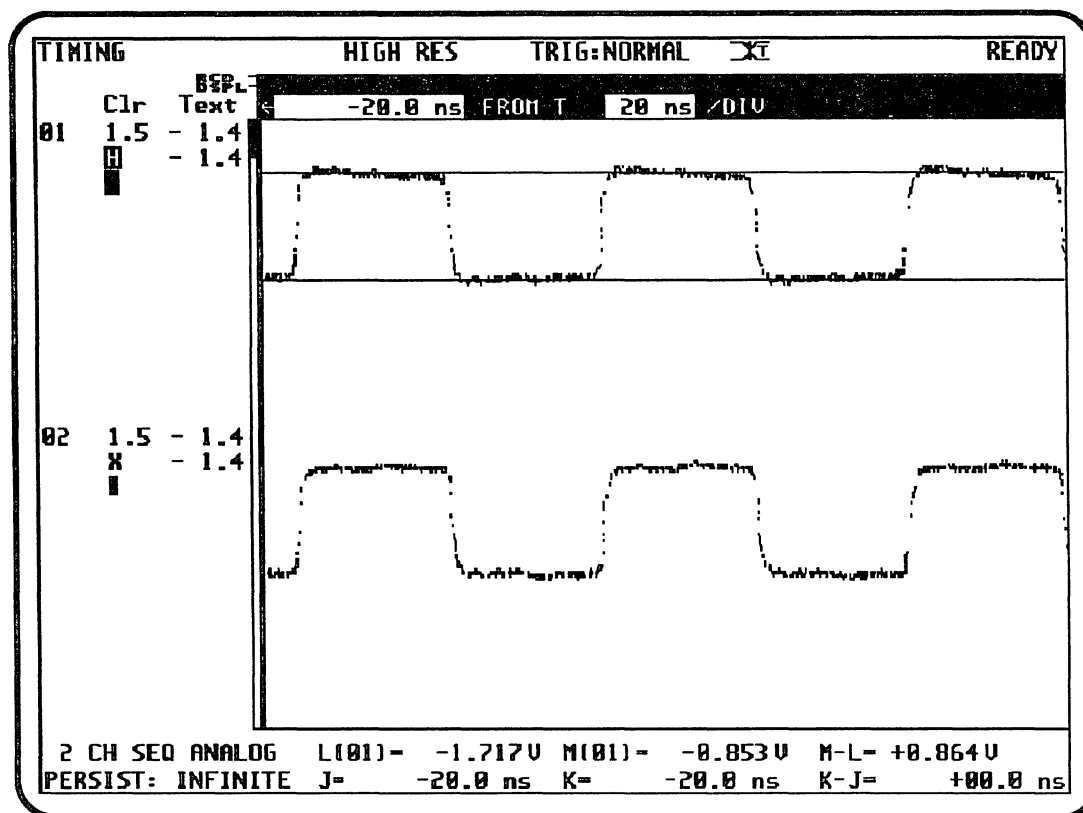

Figure 2-11. Voltage Cursor Positioning

These voltage cursors are used to measure voltage values between points on the waveform displayed in one channel. The voltage is displayed to the right of the two cursor fields in a field marked "M-L=..." One or both voltage cursors may be removed from the screen by rolling to channel 0 (off) or using the 0 key followed by the **Enter** key.

The example of Figure 2-11 shows the use of the Voltage cursors.

Return the display to the eight-channel sequential mode.

## Trigger Threshold Field

Move the blinking cursor to the Volts Threshold field of the channel where the single trigger level is entered. With the Logic Waveform Analyzer running, use the **Next** and **Previous** keys to move the Trigger Threshold Voltage value up and down until the data display loses its trigger point. Note the importance of the correct trigger threshold on the channel or channels where the trigger is used.

Return the Trigger Threshold Voltage to its correct value.

Try out the other fields on the trigger display, including Channel Trace Color, Channel Text Labels, Volts Full-Scale, and Volts Offset. Use the **Help** key to display help mes-

sages at each field to guide you to the field's purpose and the keystrokes used to enter values.

When you are thoroughly familiar with the waveform part of the display, move the blinking cursor to the bottom of the screen and experiment with the voltage and timing measurement cursors, sequential and overlaid display modes, and the various persistence modes. These modes are explained later in this manual; you can use the **Help** key or the **Index** to locate information about a specific field or topic.

## DIGITAL DISPLAY MODE

For many applications it is useful to display the recorded analog data in a digital format, much like the timing diagram display of a conventional logic analyzer. This mode provides both a single-threshold display (one-bit resolution) or a dual-threshold display (two-bit resolution). In the dual-threshold display the user must enter values for both the lower and upper threshold values. Signals between the two threshold values are represented by a cross-hatch area, as shown below.

The example of Figure 2-12 shows the Digital Display with dual threshold values set. The Dual-threshold Menu is described later in this manual.

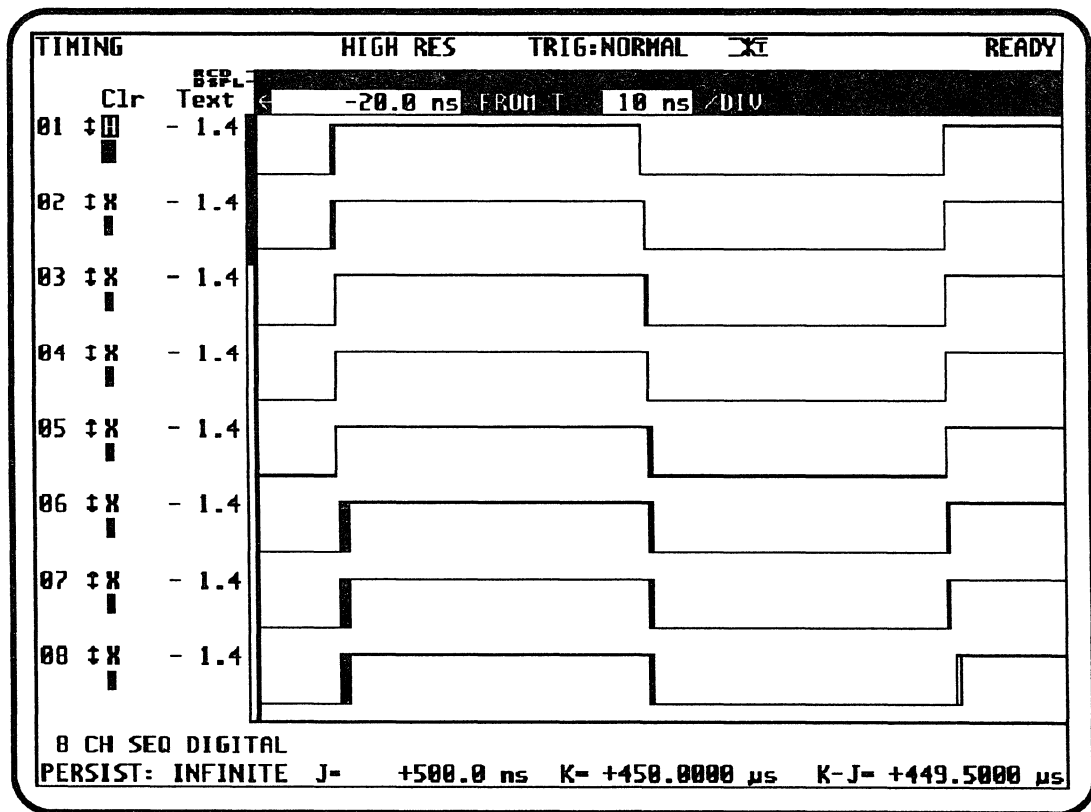

Figure 2-12. Digital-display Mode

# TIME CHART MODE

One of the most useful modes for viewing digital signals is the Time-chart Mode. This mode combines multiple signals into a single overlay. The hex value of the overlay is shown directly on the timing display, making it easy to determine the value of the data on the bus at each transition point.

An example of the Time-chart Mode is shown in Figure 2-13. The Time-chart Mode is described later in this manual.

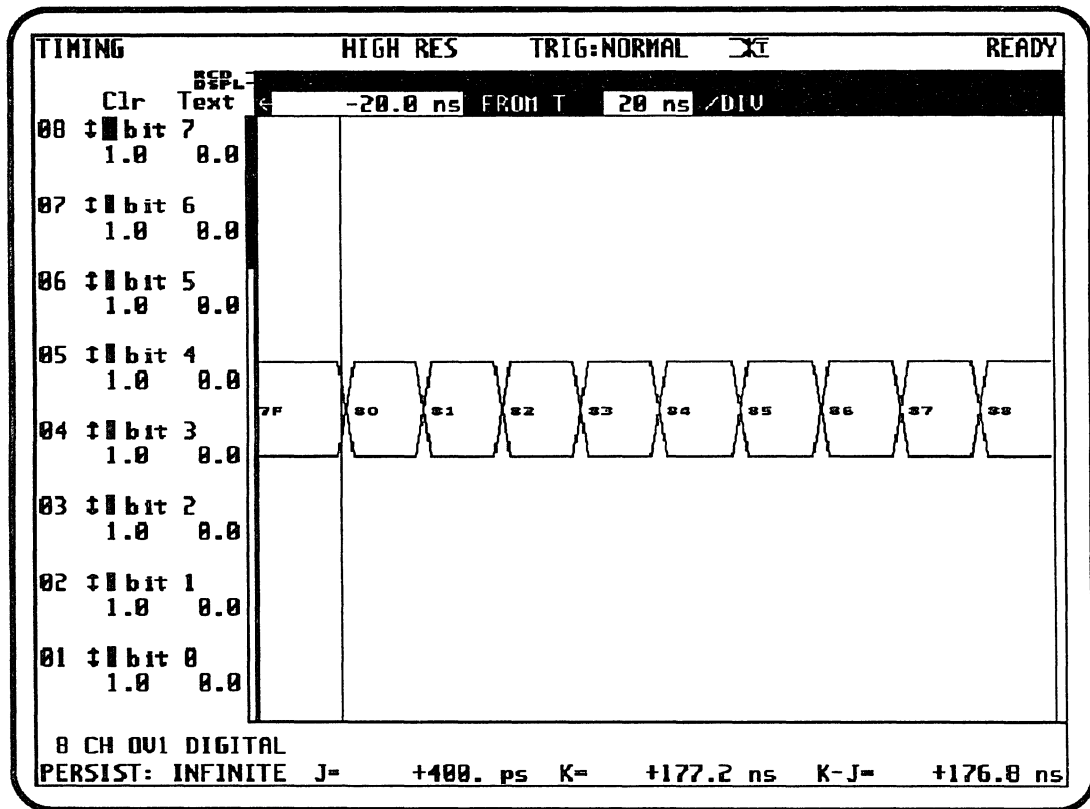

Figure 2-13. Time-chart Mode

# DISK FUNCTIONS

Press the Disk key and note that a full-size Disk Functions Menu is displayed, as shown in Figure 2-14.

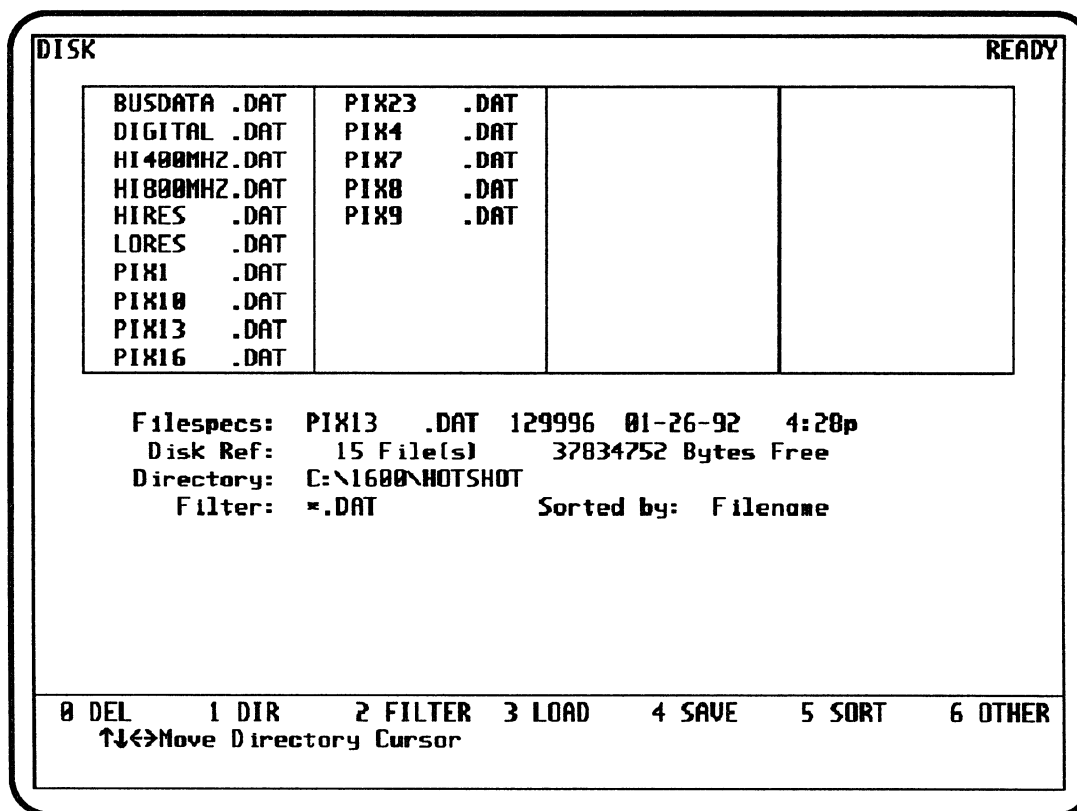

Figure 2-14. Disk Functions Menu

If there is no disk in the floppy disk drive, the message “Drive not ready” appears in the lower part of the menu.

The Disk Functions Menu allows you to use the built-in floppy disk drive for saving menu setups or menu setups and recorded data to disk, or recalling saved files from disk. If the optional hard disk drive is installed, this menu may also be used to save to, and load from, that drive.

If you would like to learn about the Disk Functions Menu now, please refer to Chapter 6 of this manual.

## MORE KEY

The **More** key is used to provide access to functions and features not available from the two main menus and/or the front-panel keypad. Examples include store and clear reference waveform displays, and selection of the optional 800 MSample Probe.

Press the **More** key and note the small pop-up menu in the center of the screen. An example is shown in Figure 2-15. Pressing this key a second time removes the pop-up menu.

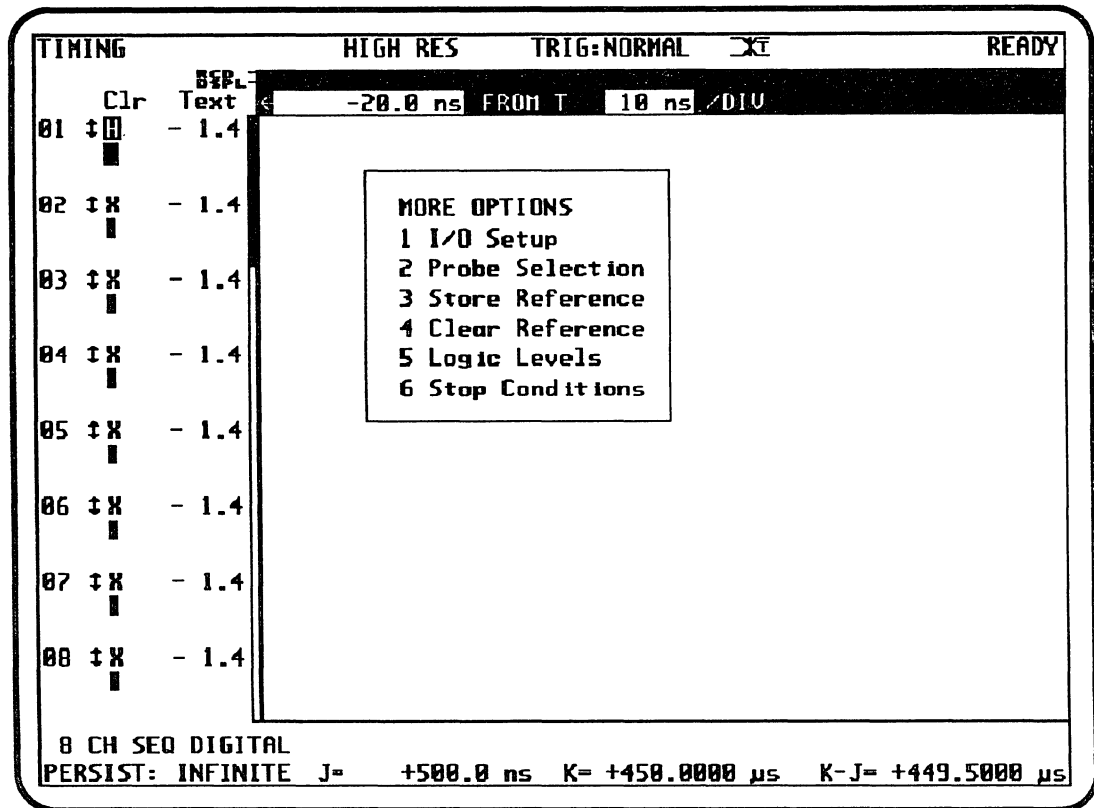

Figure 2-15. More Options Menu

Pressing any of the number keys with the More Options Menu displayed will perform the function listed or display a sub-menu for that function.

## Reference Waveforms

It is often useful to display previously-recorded waveforms on the Timing Display at the same time as new waveforms are being recorded. This allows you to compare the newly-recorded waveforms with a previously-recorded reference waveform.

Press the **More** key followed by key number **3**, Store Reference. Press the **Timing** key and note the waveforms displayed. If there were waveforms displayed before Store Reference was used, these waveforms are still displayed. However, they may now be displayed in a different shade or color. Press the **Clear** key and note that the waveforms remain on the screen.

Press the **Start** key and note that the newly-recorded waveforms are being displayed together with the reference waveforms on the screen. While the unit is recording, remove one of the input probes from the Calibration connector (but not the probe selected as the trigger bit) and note the difference in the waveform display.



Since the Store Reference function saves *displayed* waveforms, either a recorded waveform or a waveform loaded from disk may be used as the waveform to be stored (and displayed).

To clear the displayed waveform, press the **More** key again, and then press key number 4, Clear Reference. Note that the waveform is removed from the display.

## Optional 800 MSample Probe

The optional 800 MSample Probe provides single-shot sample rates up to 800 Msamples/sec on one channel or 400 Msamples/sec on two channels. The probe consists of a small pod with two probe tips, and two interface cables. One cable contains an eight-position connector which mates to a rear-panel channel input connector. The other cable contains a nine-pin, D-type connector which mates to the rear panel 800 MSample Probe connector. Up to two pods may be used with each K1600 unit.

Use the 800 MSample Probe when you require high resolution on signals which are not repetitive. It is also useful in situations where the trigger is repetitive, and you need to capture an infrequent anomaly at a high sample rate.

Press the **More** key again and then press 2, Probe Selection. This brings up a small pop-up menu which shows the probe type selected for each active probe section. When using the normal Data Input Probes supplied with the unit, both channel groups should be set to Standard. If the optional 800 MSample Probe is being used, either 400 MHz Adapter or 800 MHz Adapter may be selected. Press the **Timing** key again to remove the pop-up menu from the screen.

The use of the 800 MSample Probe is described more fully in Chapter 9 of this manual.

This concludes the Logic Waveform Analyzer tutorial. Please refer to the remainder of the manual for more detailed descriptions of other Analyzer features and screens.

## ***Chapter 3***

# **FRONT PANEL**

---

## **OVERVIEW**

### **Introduction**

This chapter describes the front panel of the Logic Waveform Analyzer and includes a description of associated components. You may use this information to learn about individual keys and their operation as well as the menu fields accessed by these keys. This information provides a reference for functions you may not have used in the beginning.

The front panel is divided into four functional groups, as follows, each of which is described in subsequent paragraphs:

- CRT Display
- 39-key Keypad plus Scroll Knob
- 3.5" Floppy Disk Drive
- AC Power Switch

It is best to have the Logic Waveform Analyzer powered up and close at hand when using this section of the manual, as this will allow you to try out the operations described in this section. Figure 3-1 shows the arrangement of front panel components.

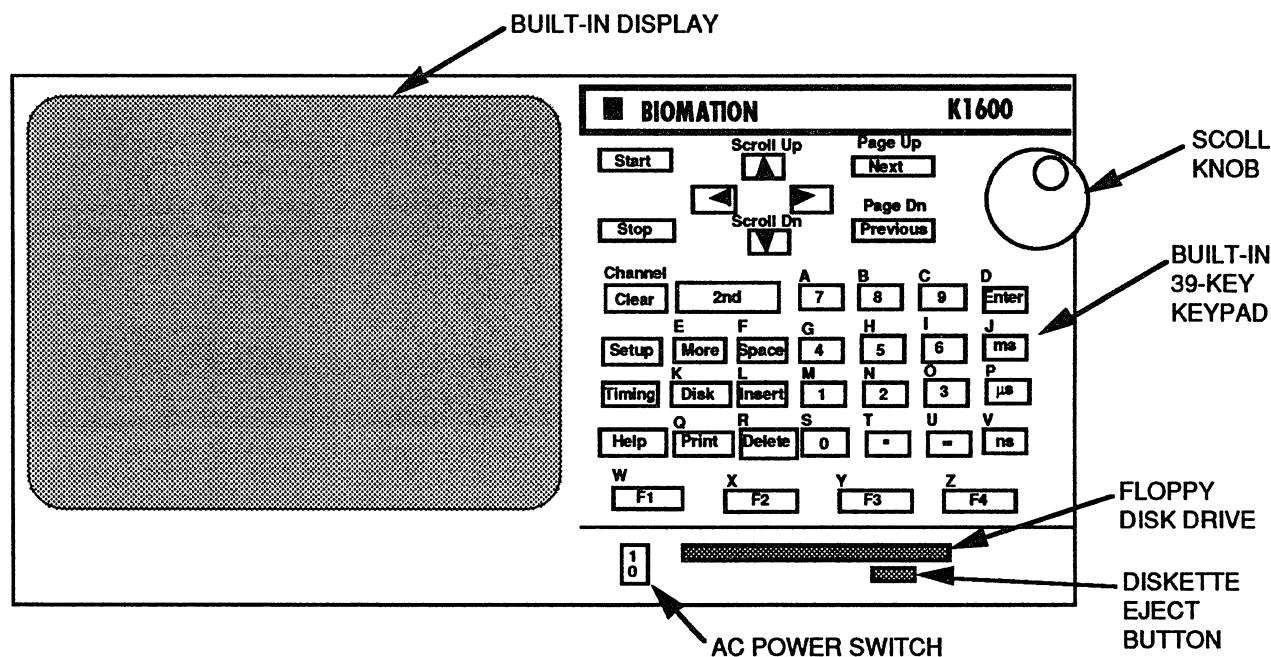

Figure 3-1 Front Panel Components

## CRT DISPLAY

The built-in CRT display provides both menu entry and data display for all Logic Waveform Analyzer functions. This high-resolution screen utilizes shading to separate the menu areas from the recorded-data display, making it easy for you to locate menu parameters and displayed data. While the menu areas and background colors are fixed, you may select from three shades for displaying recorded waveforms. For example, you might show an important signal as bright while you might show the remainder of the waveforms as less bright.

Upon power-up, the display shows the Timing Screen, a combined menu/data display screen which displays the most-used menu fields and up to 16 channels of recorded data. If you require additional menu fields for a setup, you may display other menus as described below.

Figure 3-2 shows a typical Timing Display.

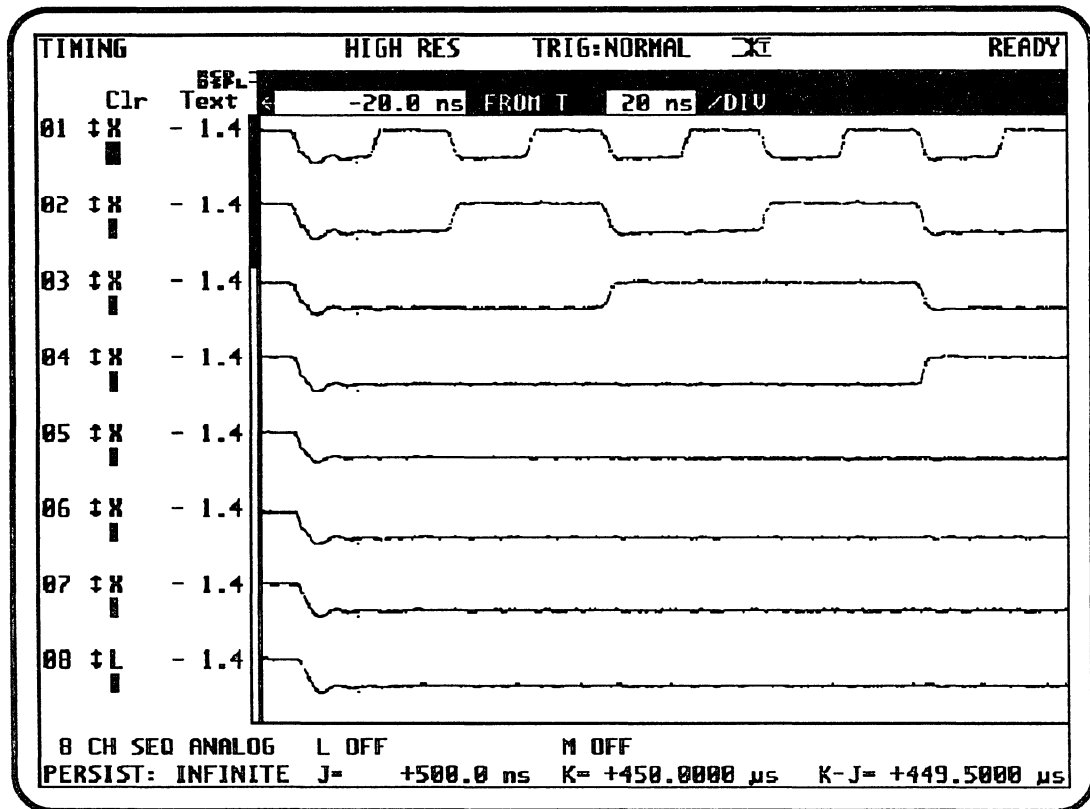

Figure 3-2. Analog Timing Display

The front surface of the CRT is the front of the glass tube, which may be cleaned with water or glass cleaning solution.

**CAUTION:** Take care to avoid scratching or other abuse of the surface of the CRT. If damaged, the entire video monitor must be replaced as a unit. In addition, rough handling or other damage could crack the CRT and cause it to implode.

## KEYPAD

### Overview

The front-panel keypad (Figure 3-3) provides control of all menu fields and all start/stop/clear screen functions. The keys are grouped into functional areas as follows:

- Cursor movement keys
- Next/Previous keys
- Number/units keys
- Function keys

- 2nd keys
- Start/Stop/Clear and other keys

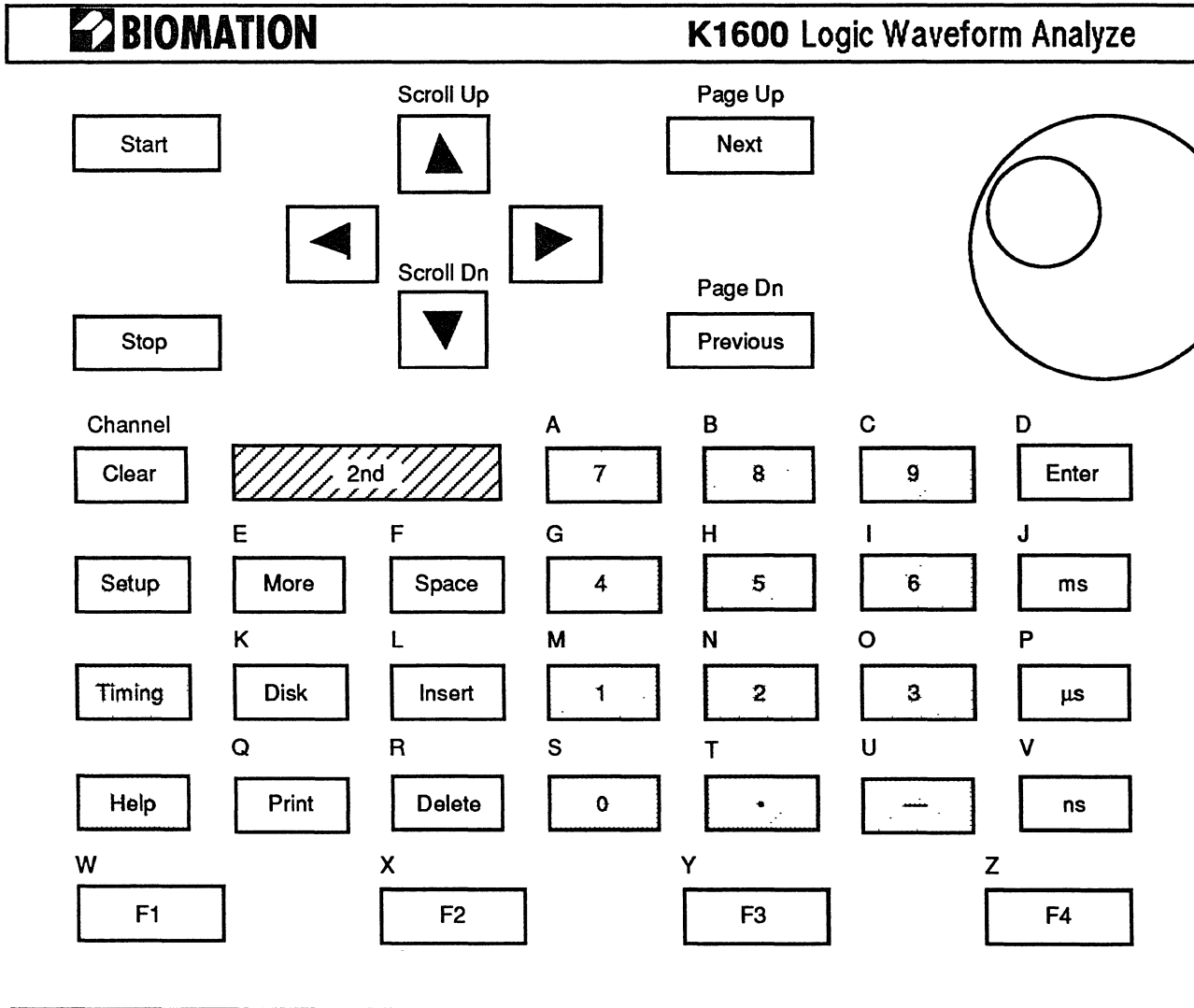

White

Blue

Gray

Figure 3-3. Keypad Details

## Cursor Movement Keys

The four cursor movement keys (white) are marked with an arrow which corresponds to their cursor movement direction. These keys are used to move the white cursor from field to field on each display screen.

Cursor movement features vertical rollover which allows quick movement from the bottom of the screen back to the top, and from the top to the bottom. The cursor movement keys are repeating keys; holding the key down will move the cursor continuously in the direction shown on the key.

## Next/Previous Keys

The **Next** and **Previous** keys (white) are used to increment and decrement the numerical value in the field at the cursor location. If the field contains text selections, the **Next** and **Previous** keys will “roll” the values in sequence from one choice to the next, rolling over to the first choice after the last choice.

For example, the **Next** key will increment the displayed value at the Time Per Division field, while the **Previous** key will decrement the displayed value.

The **Next** key will roll through the following choices at the Trigger field:

NORMAL, AUTO, SINGLE, and back to NORMAL

In the same manner, the **Previous** key will roll through these choices:

NORMAL, SINGLE, AUTO, and back to NORMAL

With the white cursor on any channel designator (channel number) the **Next** key will roll the displayed data from the channel number up to a maximum of channel 16, then roll over to OFF (no data displayed).

One more push of the **Next** key will return the value to 01. The **Previous** key performs the same function but in the reverse order.

## Number/Units Keys

This section of the keypad has 16 keys (12 gray, four white) which are grouped together in a square. The 10 numeric keys are used to enter numerical values in any of the screen fields which accept these values. Additional keys provide a decimal point, a minus sign (negative value), and time and voltage units.

The numeric keys enter values starting in the right side of the field at the cursor, and continue at this point until the desired number is displayed. The **Enter** key is then used to enter the displayed value. The **Enter** key should always be used to ensure that the displayed number is actually accepted. If the displayed value is greater than the field can accept, the software will automatically enter the highest legal value for that field.

In fields where a measurement unit is associated with the entered value, the desired units key may be used to enter the displayed value. For example, the Time Per Division

field requires a unit for the displayed value, either nanoseconds, microseconds, or milliseconds. Any of the units keys may be used both to select the desired measurement unit and enter the displayed value. The measurement units keys are as follows:

- **ms** (milliseconds), **μs** (microseconds), and **ns** (nanoseconds)
- The **Enter** key (white) selects seconds or volts for time and voltage fields respectively

## 2nd Key

The **2nd** key (blue) is used to obtain the second (shifted) function for another key, thereby increasing the total number of key choices available on the front panel. The second function for a key is labeled on the keypad above the affected key in blue color. The **2nd** key must be pressed initially and then released prior to pressing the other key for the shifted function.

Whenever the **2nd** key is pressed, the message “2<sub>nd</sub>” appears in the upper-left-hand corner of the screen for approximately five seconds to indicate the second function is active. Pressing another key while this message is displayed will enter the second function for the affected key. If the message times out before the other key is pressed, it will be necessary to press the **2nd** key again and then press the affected key.

For example, pressing the **2nd** key and then pressing the **7** key will enter an “A” character into the active cursor field. The **2nd** key does not lock and must be pressed before each key to obtain the second function.

The **2nd** key can also be pressed and held down while several individual keys are pressed to enter their shifted functions at the same time.

The **Clear/Channel** key (white) clears data from the display on the channel where the blinking cursor is located. This is a second-key function and is activated by first pressing the blue **2nd** key, then the **Clear** key.

The **Page Up** and **Page Dn** keys are used to move the entire timing display up or down a “page” at a time. This is particularly useful when the timing display is in the two- or four-channel mode.

The **Scroll Up** and **Scroll Dn** keys are used to scroll through the 32 available channel display positions, one position at a time.

The remaining second-key functions provide the entire alphabet, and are used for entering labels into the timing and setup displays or for alphanumeric filenames for the Disk Functions Menu.

## Start/Stop/Clear Keys

The keys located on the far left of the front panel might be considered “operating keys,” as these keys are used repeatedly while the instrument is in use. They allow the user to

start and stop the unit, clear individual or all channels, display additional menus, and display help messages for the selected cursor location.

A brief description of each key is as follows:

- **Start**—This key (white) begins data collection in the mode of operation selected. This key does not clear the screen; if data was displayed previously, new data will be displayed together with the previous data.
- **Stop**—This key (white) stops data collection. All recorded data remains on the screen for future analysis.
- **Clear**—This key (white) clears the display of all waveform information. It operates at all times, whether the Analyzer is running or in the idle mode.
- **Clear/Channel**—This key (white) is accessed by pressing the **2nd** key with the **Clear** key and is used to clear the waveform of the channel where the white cursor is located. If the white cursor is not located on a data channel, this key has no effect.

If the unit is stopped, pressing the **Clear/Channel** key a second time will restore the waveform on that channel. The **Clear/Channel** key may also be used to restore data cleared by the **Clear** key, as long as the unit is stopped.

- **Setup**—This key (gray) selects the Setup Menu as the active display.
- **Timing**—This key (gray) selects the Timing Screen as the active display.
- **Help**—This key (gray) causes a brief help message about the field at the present blinking cursor location to be displayed.
- **Disk**—This key (white) selects the Disk Functions Menu as the active display.
- **More**—This key (white) provides access to additional menus, including I/O Setup, Store Reference, Clear Reference, logic levels, the digital display mode, and stop conditions.
- **Print**—This key (white) causes the screen image to be saved to a disk file or output through the RS-232 serial I/O port or parallel I/O port.
- **Space**—This key (white) may be used in text fields for spacing.
- **Insert** and **Delete**—These two keys (white) are used in text fields to insert and delete characters and may be used on the Timing Screen to insert and delete channels.

## SCROLL KNOB

The **Knob** increments and decrements a displayed value for data and commands in the field at the current cursor location.



## FLOPPY DISK DRIVE

Just below the keypad area is the floppy disk drive. Used it to save and load menu setups and recorded data. The drive accepts 3.5" floppy disks (DSHD) and allows you to format blank disks for use with the unit.

You may use formatted disks save menu setups and/or recorded data for future use or display. This greatly reduces the time required to set up the Logic Waveform Analyzer for often-used tests and measurements, and provides a permanent record of signals taken at an earlier time. You may recall stored signals from disk for analysis or comparison, or for printing to a printer.

Insert floppy disks into the disk drive face up, with the spring-loaded metal cover toward the rear of the unit. When the disk offers slight resistance, push firmly until the drive accepts the disk.

To eject a disk after use, a small push-button on the right of the drive releases the disk and ejects it part-way out for easy retrieval.

You should remove floppy disks from the disk drive before the unit is powered down or transported.

## AC POWER SWITCH

AC power is applied and removed at the K1600 by operating this two-position rocker switch located adjacent to the floppy disk drive. This switch is labeled **0** and **1** to indicate power off and on positions respectively. An audio beep sounds when AC power is applied.

## **Chapter 4**

# **TIMING SCREEN**

---

## **OVERVIEW**

### **Introduction**

This chapter describes the Timing Screen, which is the most frequently used screen on the Logic Waveform Analyzer. This screen contains many menu items which define the operating mode and trigger pattern as well as display of up to 16 data channels. This screen contains two Timing and two Voltage cursors in the waveform display area for making timing and voltage measurements.

The Timing Screen is the first screen displayed after power-up, and may be displayed at any time by pressing the **Timing** key.

Figure 4-1 shows an example of the Timing Screen.

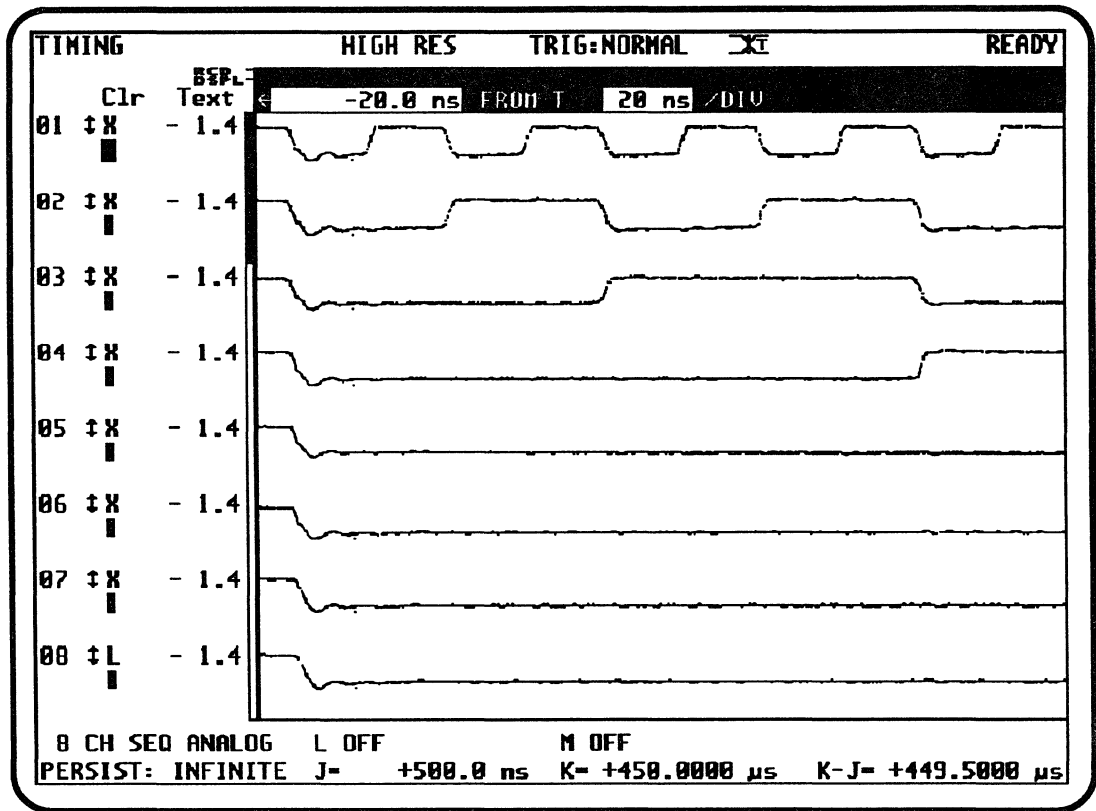

Figure 4-1. Timing Display and Setup Parameters

The model K1600 Logic Waveform Analyzer has an “Autosave” feature which saves the current setup parameters when the instrument is powered down and restores these parameters when power is reapplied. This time-saving feature sets the menus for the user, providing the test situation is the same as it was when the instrument was last used.

Because of this feature, the initial screen on the unit you are using may be somewhat different from the pictures which follow. As you become familiar with the unit you will learn how to change menu parameters for your use.

### Screen Layout

The top line on the Timing Screen contains fields to define the Vertical Resolution, the Trigger Mode, and the Trigger Filter (if used). In addition, a Status Display Window in the upper-right-hand corner shows the current status of the Analyzer (e.g., Ready, Waiting for trigger, etc.).

The second line (marked RCD for recorded data and DSP L for displayed data) shows a graphical display of the relative size of recorded data and the display window. This indicator allows the user to see the relationship of displayed data to the Analyzer memory area.

The third line allows selection of the position for the first sample in memory relative to the Trigger Event (Time Left Edge) and Time Per Division (the "Resolution" of recorded data).

The left-hand portion of the screen is associated with the displayed waveforms, with several fields for each waveform. From this section of the screen, you may enter the Channel Number, Volts Full-Scale, Volts Offset, Trigger Logic level, Trigger Threshold, Text Label, and Waveform Display Color.

The line above the bottom line allows selection for the number of channels displayed (two to 16) and their method of display (i.e., Sequential or Overlaid, Analog or Digital). The Voltage Cursor fields, L and M, are also contained on this line.

The bottom line allows selection of Persistence which is the time duration each data point for the signal trace remains on the screen. This line also allows selecting the Timing Cursor fields, J and K.

## MENU FIELDS

### Vertical Resolution

The Vertical Resolution allows the user to select low or high resolution by moving the blinking cursor to this field and using the **Next** or **Previous** key to roll to the desired mode.

- **LOW RES** (low-resolution mode) records using a four-bit A/D converter and provides 16 vertical points on the waveform. This mode results in a fast screen update and is satisfactory for many logic test applications.
- **HIGH RES** (high-resolution mode) records in an effective six-bit mode and provides 60 vertical points on the waveform. This mode requires approximately four times as long to update the screen. However, better resolution is obtained to provide maximum signal detail.

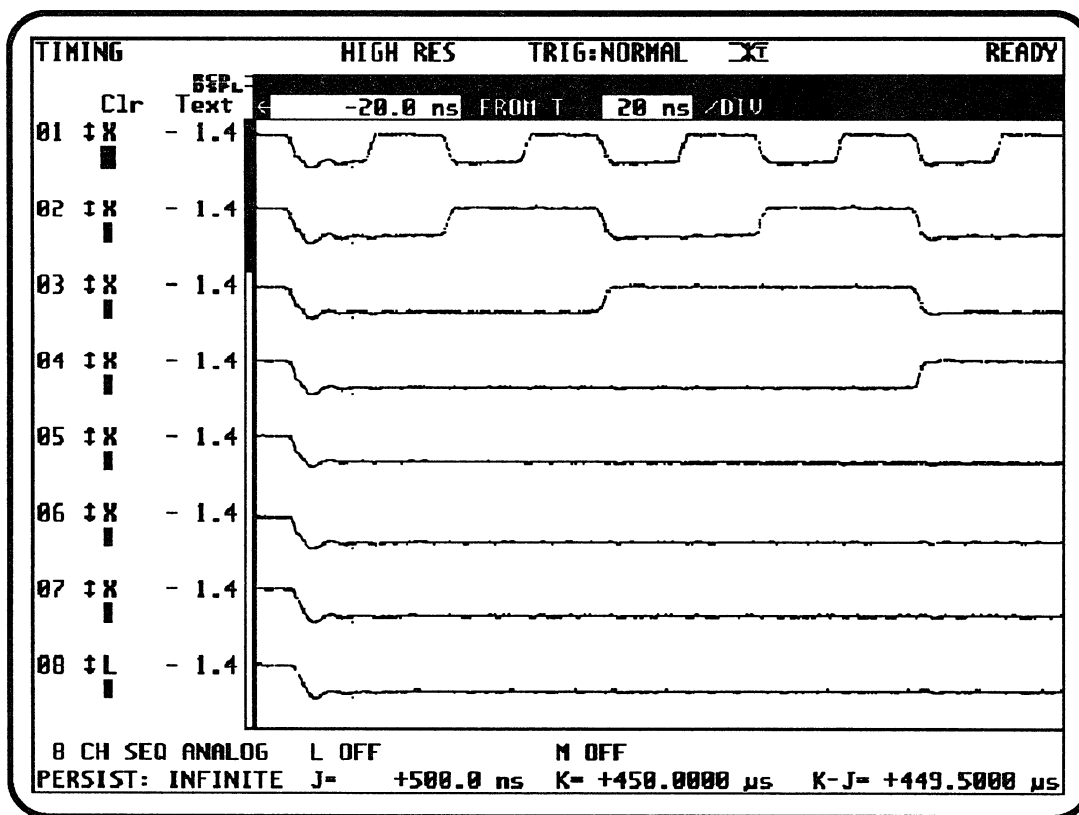

Figure 4-2. Timing Display, TRIG=NORMAL Selected

### Trigger Selection

The Trigger Selection (Figure 4-2) allows the user to define Trigger Mode, Trigger Event, and Filter Parameters.

Once these values have been set, the bit pattern (combination of highs and lows) may be set as described below.

### Trigger Mode







Three Trigger Modes are available to provide considerable flexibility in selecting a suitable triggering mode for each application. The mode selected determines both the waveform display as well as the resolution or detail which may be observed. The three choices are:

- TRIG:NORMAL** In this mode, a recording is completed only when a Trigger Event occurs, no matter how long this takes. This mode is used for repetitive recordings, and provides the highest time resolution.

- TRIG : AUTO** In this mode, a recording is completed automatically if the specified Trigger Event does not occur within a certain interval. This mode is used only to examine data or to determine a suitable trigger condition.
- TRIG : SINGLE** In this mode, a single recording is completed when the first trigger occurs. This mode is used for single-shot recording.

## Trigger Event

Six Trigger Event conditions are provided, each of which is represented by graphic symbols on the top line of the screen. These symbols attempt to show how the trigger circuitry works in each selection and should guide the user to the selection of the appropriate Trigger Event.

-  Unit triggers when the specified bit pattern goes true.
-  Unit triggers when the specified bit pattern goes false.
-  Unit triggers when the specified bit pattern is true for > or < the filter time period. Note that trigger occurs at the point where the pattern goes false, since the instrument must measure the period that the pattern was true.
-  Unit triggers when the specified bit pattern is false for > or < the filter time period. Note that trigger occurs at the point where the bit pattern becomes true again.
-  Unit triggers when the time between consecutive true edges is > or < filter time period. Note that the trigger occurs at the point where the trigger goes true for a second time.
-  Unit triggers when the time between consecutive false edges is > or < filter time period. Note that the trigger occurs at the point where the trigger goes false for a second time.

## Trigger Filter Qualifier

The Trigger Filter Qualifier allows the user to specify whether the Trigger Event is to be greater (>) than a specified time period or less (<) than a specified time period.

## Trigger Filter Duration

The Trigger Filter Duration allows the user to specify the time period required to satisfy the Trigger Event, from 5 ns to 80 ms. This wide-range time filter accommodates nearly every digital application.

## Status Window

The far-right section of the top line shows the current status of the Logic Waveform Analyzer. The status is updated continuously during operation and provides an up-to-date readout of the unit's progress through a recording sequence.

The following messages and their description are used in the Status Window:

DEMO	No Hardware; used when the K1600 software is run on a PC without Logic Waveform Analyzer hardware.
READY	Indicates completion of power-up self test and ready for operation.
RUNNING	In normal operation, this status message is displayed when the <b>Start</b> key is pressed. When the device waits longer than one second for the Enable or Trigger, the appropriate status is displayed. Often, this is the only status message displayed during the recording process.
XXXXXXX	When a Stop Condition is selected, a numeric value is displayed instead of the <code>RUNNING</code> message, indicating the number of passes (record cycles) completed.
DELAY	Indicates the unit is triggered and is waiting for the data memory to be filled (long post-trigger delay).
ENABLE ?	The device is waiting for the external trigger enable.
TRIGGER ?	The device is waiting for the trigger event.

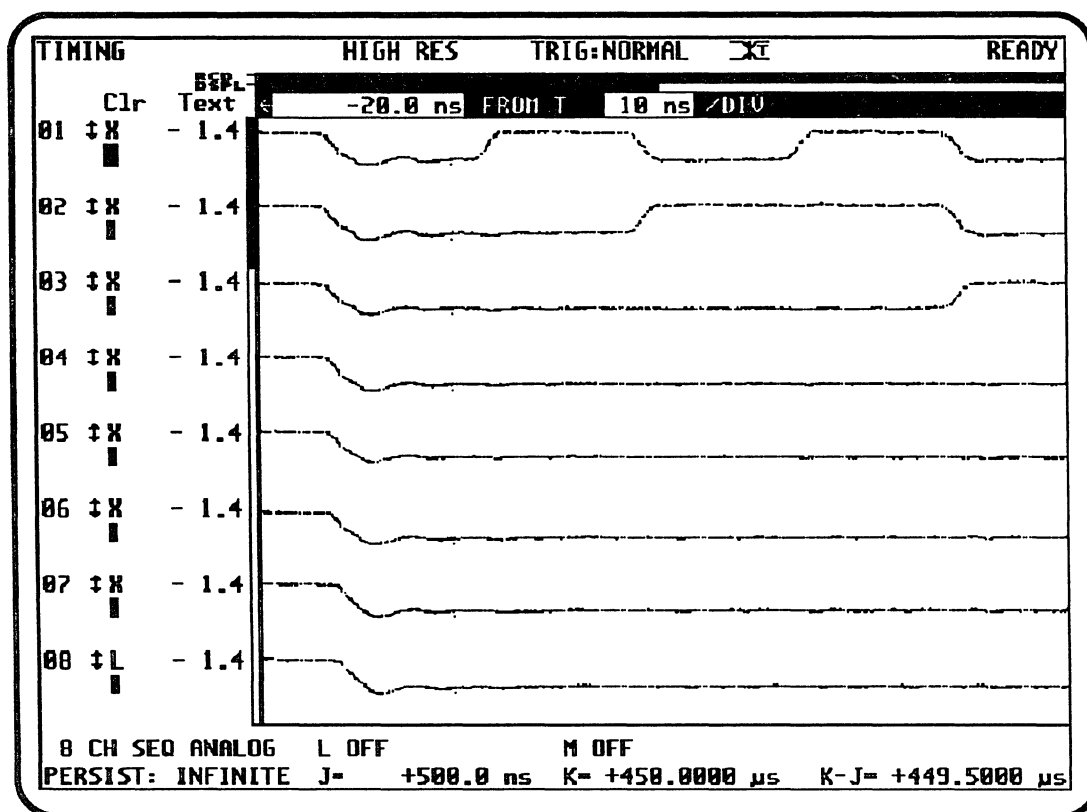

Figure 4-3 Timing Display, Memory Size Bars RCD and DSPL

## MEMORY SIZE BARS

### Horizontal Indicator Bars

Two bright horizontal bars, located near the top of the screen (Figure 4-3), fill the area immediately below the mode and trigger selection fields. These two bars show the comparison for total memory size of recorded data versus the amount of this memory used for displayed data.

The top bar marked RCD (recorded data) shows the relative capacity size of the 1K samples of recorded data in memory.

The bottom bar marked DSPL (displayed data) shows the relative size of the data portion displayed in the Timing Display window. This bar indicator provides you with a quick reference for comparing the amount of memory displayed in relation to the position of the display window in the total memory capacity.

Figure 4-4 shows the comparison of data memory versus display window for these memory size bars.



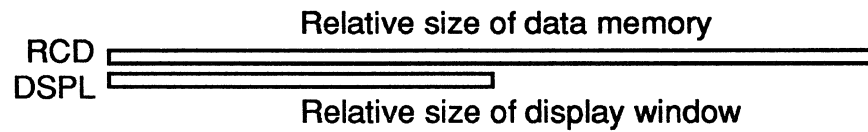

Figure 4-4. Horizontal Indicator Bars

## Vertical Indicator Bar

The single vertical bar just to the left of the waveform display area is the Display Area Indicator. This bar shows the displayed data channels relative to the 32-channel capacity of the display area. The overall vertical height of the bar represents the number of channels displayed (16/8/4/2).

The position of the bright bar within the display area represents the position of the display window within the 32-channel display area. The position of the display window may be changed by using the **Scroll Up**, **Scroll Dn**, **Page Up** and **Page Dn** keys.

Figure 4-5 shows the comparison of window area versus display area for the Display Area Indicator.

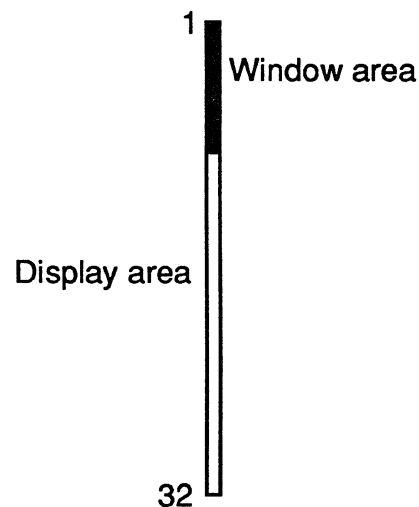
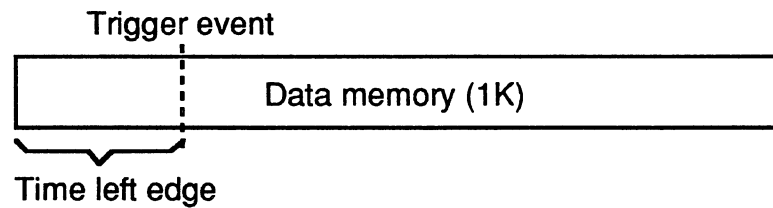

Figure 4-5. Vertical Indicator Bar

## TIME FIELDS

### Time Left Edge

The Time-Left-Edge field allows you to specify the location of the first sample in memory relative to the position of the trigger event. By specifying this value, you determine the part of a continuous data stream which is stored in the Analyzer memory and available for display. Figure 4-6 illustrates the use of this field.



**Figure 4-6. Trigger Event Displacement by Time Left Edge**

The Time-Left-Edge field interacts with, and is subordinate to, the Time-Per-Division field described below. That is, the value selected for the Time-Per-Division field determines the range of values allowed for the Time-Left-Edge field.

Table 4-1 shows legal ranges for the Time Left Edge as a function of Time Per Division.

In use, set the time of the left edge relative to the Trigger Event and then enter the desired Time Per Division. In this way, the decision of where to position the left edge determines the maximum resolution of the final display.

## Time Per Division

The value in the Time-Per-Division field determines the resolution of displayed data. As explained above, the setting of the Time-Left-Edge field limits this field. Maximum resolution is available only when the Time-Left-Edge value is not more negative than  $-10 \mu\text{s}$ .

The range is 1 ns per division to 500 ms per division.

For 5 ns per division through 500 ms per division, the Analyzer plots one hundred data points per division, so the effective sample period is 1/100 of the time per division. At 5 ns per division, this gives the maximum available effective resolution of 50 ps per sample.

At 1 ns per division or 2 ns per division, the effective resolution is held at 50 ps per sample, but the Analyzer expands the data points horizontally to give the requested time per division. This is useful for examining fine detail.

Table 4-1. Range of Time-Left-Edge for Specified Time-per-Division

<i>Time-Per-Division</i>	<i>Most Negative Time at Left Edge</i>	<i>Most Positive Time at Left Edge</i>
1 ns	-10 $\mu$ s	+640 $\mu$ s
2 ns	-10 $\mu$ s	+640 $\mu$ s
5 ns	-10 $\mu$ s	+640 $\mu$ s
10 ns	-20 $\mu$ s	+1.28 ms
20 ns	-20 $\mu$ s	+1.28 ms
50 ns	-100 $\mu$ s	+6.4 ms
100 ns	-200 $\mu$ s	+12.8 ms
200 ns	-200 $\mu$ s	+12.8 ms
500 ns	-1 ms	+64 ms
1 $\mu$ s	-2 ms	+128 ms
2 $\mu$ s	-2 ms	+128 ms
5 $\mu$ s	-10 ms	+640 ms
10 $\mu$ s	-20 ms	+1.28 s
20 $\mu$ s	-20 ms	+1.28 s
50 $\mu$ s	-100 ms	+6.4 s
100 $\mu$ s	-200 ms	+12.8 s
200 $\mu$ s	-200 ms	+12.8 s
500 $\mu$ s	-500 ms	+32 s
1 ms	-500 ms	+32 s
2 ms	-500 ms	+32 s
5 ms	-500 ms	+32 s
10 ms	-500 ms	+32 s
20 ms	-500 ms	+32 s
50 ms	-500 ms	+32 s

## CHANNEL AND DISPLAY PARAMETERS

The left vertical section of the Timing Screen controls the display of waveforms on the screen, the Data Input Parameters associated with each displayed channel, the Trigger Bit Pattern, and the Trigger Threshold.

The example in Figure 4-7 shows the Timing Display and Data Input Parameters.

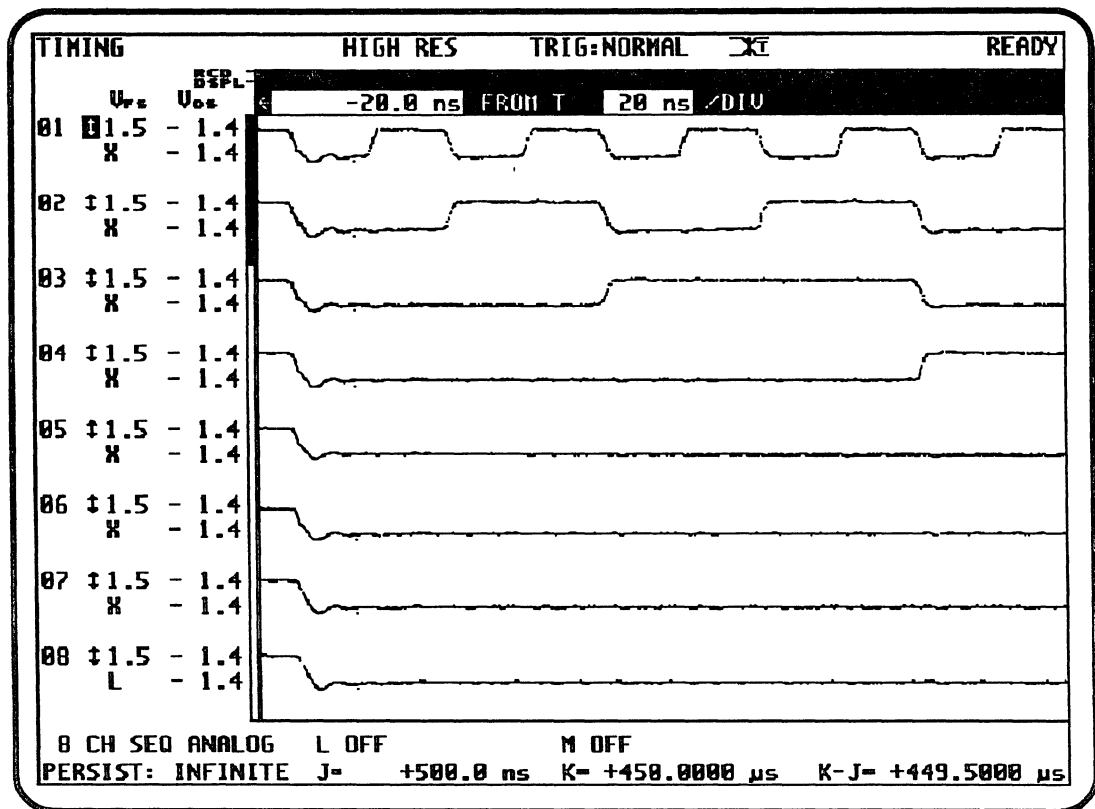

Figure 4-7. Timing Display, Channels 01-08 Parameters

## Channel Selection

Up to 16 channels of timing information may be displayed at one time, with any channel in any position. Channels may be duplicated on the same screen if desired.

The channels to be displayed are selected in one of three ways:

- By entering the desired channel number into one of the positions, followed by the **Enter** key
- By entering the desired channel number into one of the positions, and then by moving the blinking cursor to another field
- By rolling the displayed channel number up or down with the **Next** or **Previous** keys or the **Knob** to the desired channel number

One or more channels may be “blanked out” by entering a zero at the desired location, or by rolling the displayed channel number up or down to zero. Breaks between channels are often used to group signals together for added clarity.

## Field Display

When eight or 16 channels are displayed at one time, there is not enough room on the screen to display all parameters associated with each displayed channel. Parameters are displayed in the following groups, which are accessed by placing the blinking cursor on any of the double-ended vertical arrows and using the **Next** and **Previous** keys to roll until the desired display is visible.

- Channel displayed, Volts Full-Scale, Volts Offset
- Channel displayed, Trigger, Volts Threshold
- Channel displayed, color, alphanumeric label
- Channel displayed, vertical position = XXX (active in overlay display mode only)

Note that the Setup Menu may be used for a complete view of all parameters except vertical position.

## Channel Volts Full-Scale

There is a separate Volts Full-Scale field for each displayed channel. This field is used to set the vertical sensitivity of the Logic Waveform Analyzer, that is, the height of the displayed waveform within the space allocated for each channel display.

Like a traditional two- or four-channel oscilloscope, the separate field for each displayed channel allows the display of many signals of different voltage levels on the screen at the same time. For example, TTL and ECL signals may be displayed together, or the AC component on a power supply line together with address and data signals. The creative use of the Volts Full-Scale and Volts Offset values allows measurements which are impossible to make with any other instrument.

The Volts Full-Scale range is from 1.0 V to 10.0 V in 0.1 V increments.

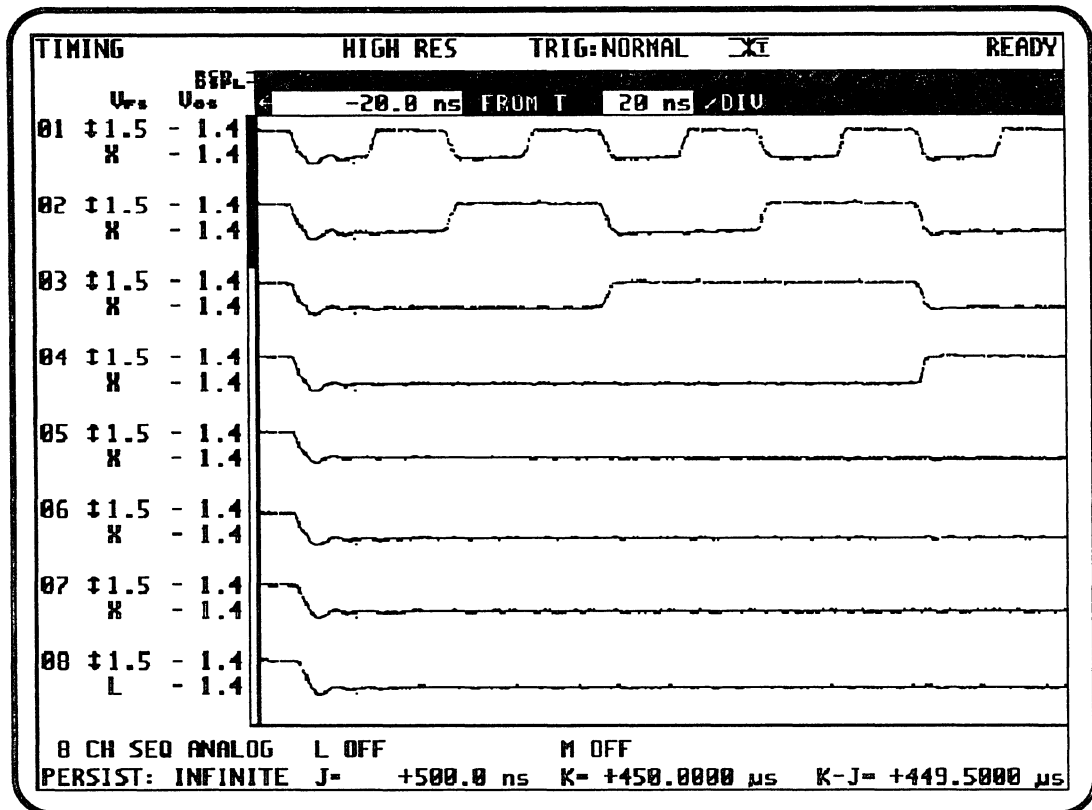

Figure 4-8. Timing Display with Volts Offset (Vos)

## Channel Volts Offset

There is a separate Volts Offset field for each displayed channel. This field is used to set the position of the waveform within the space allocated for each channel display. The value displayed represents the midpoint of the allocated space for the channel displayed. The example in Figure 4-8 shows the Volts Offset fields.

The Volts Offset field and the Volts Full-Scale field described above provide a great deal of flexibility in displaying large and small signals from -40.0 V to +40.0 V. As a general rule (or “starting point”) the Volts Full-Scale value should be set to a value slightly above the maximum peak-to-peak voltage of the signal on each channel, and the Volts Offset value should be set to the midpoint of the signal.

The Volts Offset range is from -40.0 V to +40.0 V, in 0.1 V increments.

## Channel Trigger Level

The Channel Trigger Level field specifies whether a channel is to be included in the overall trigger definition and what logic level is required to satisfy the trigger condition on this channel.

The default value in the Channel Trigger Level for each channel is an “X” (sometimes called a “don’t care”). The don’t care designation indicates that particular channel is not part of the overall trigger definition. An “L” designation is used where the voltage on the selected channel must be lower than the Trigger Threshold specified, while an “H” designation is used where the voltage on the selected channel must be higher than the Trigger Threshold specified.

The **Next** and **Previous** keys are used to roll the Channel Trigger Level to the desired value on each channel.

Note that the default condition (all “don’t cares”) is *undefined* and does not provide a suitable trigger for either the **NORMAL** or **SINGLE** modes.

## Channel Volts Threshold

The Channel Volts Threshold specifies the threshold voltage for the Channel Trigger Level described above. This is the voltage value below which the input signal is defined as a “low” and above which the input signal is defined as a “high.” If the Channel Trigger Level is left at “x” (don’t care value), then the Channel Volts Threshold value has no effect.

The Channel Volts Threshold value is always shown when two- or four-channel displays are selected, and may be displayed in eight- or 16-channel modes using the double-ended vertical arrow field as described above.

The example in Figure 4-9 shows another way to display the trigger setup.

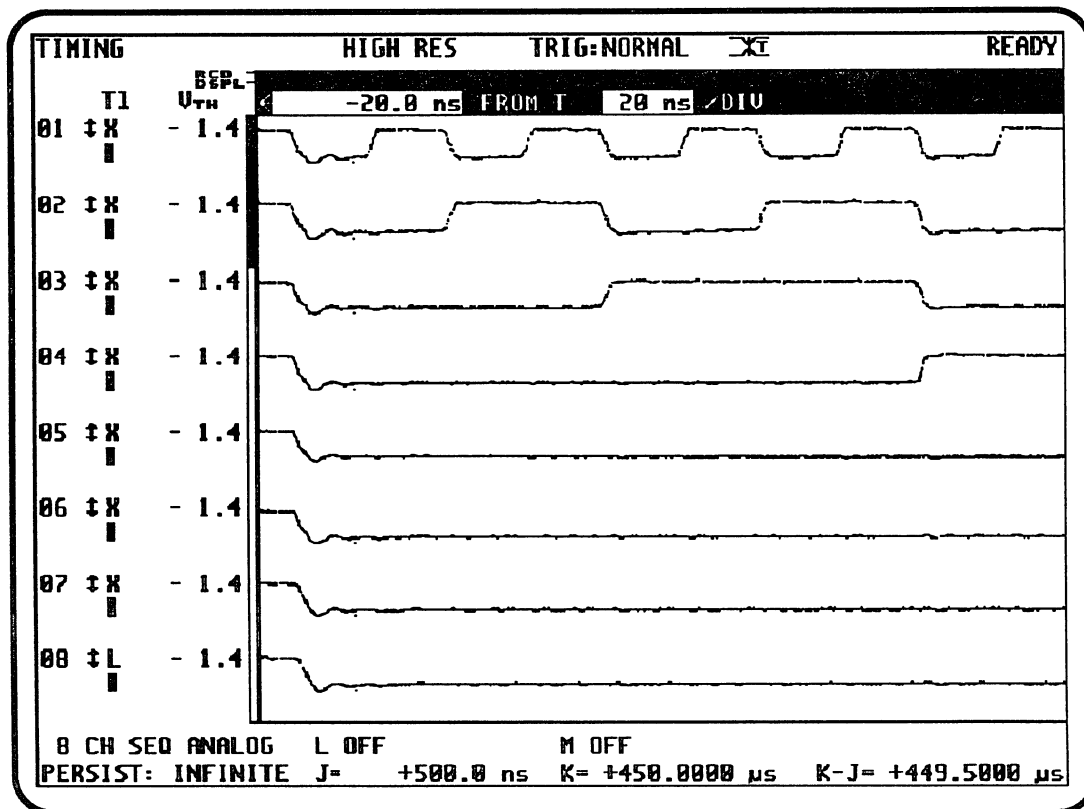

Figure 4-9. Timing Display with TI Value for Trigger

The **Next** and **Previous** keys are used to roll the Channel Volts Threshold to the desired value, or the value may be entered using the numeric keys followed by the **Enter** key. The range of this field is +40.0 V to -40.0 V in 0.1 V increments. Note that this value may be changed for many channels at one time on the Global section of the Setup Menu. The value is limited to the range  $V_{os} + 4$  V to  $V_{os} - 4$  V.

As a general rule, the Channel Volts Threshold value should be at the midpoint of the signal being measured on each channel. When using a standard logic family such as TTL or ECL, the trigger threshold should be set to the logic threshold for that family. The value should be well away from any ringing or other disturbances on the line, because these conditions could cause multiple signals to be recorded or block the correct operation of the Trigger Filter.

Another use for this field is to set the Channel Volts Threshold value of one channel just above, or just below, the expected signal limits. Triggering will occur if the signal level exceeds the value specified.

### Channel Trace Color

An external VGA color monitor may be used to display the menus and waveforms in full-color. A jumper cable on the back panel connects the video output back into the



K1600 for display on the internal monochrome monitor. If this jumper cable is removed, an external VGA color monitor may be connected directly to the video output connector. Please note that the video output signal cannot be used with CGA or EGA color monitors.

The Waveform Color field allows you to specify the color of each waveform on the Timing Screen. Using different colors for important signals helps these signals stand out and be easily recognized, particularly when you use the 16-channel mode. In the overlaid display, different colors are essential for separating different signals on the screen.

When the blinking cursor is on the Channel Trace Color, use the **Next** and **Previous** keys to roll the waveform color through the choices indicated in Table 4-2. This table shows the corresponding display characteristics for a built-in, monochrome CRT versus an external color monitor.

**Table 4-2. Variation In Color Selections for Internal/External Display**

<i>Built-in CRT</i>	<i>External Color Monitor</i>
Medium	Orange
Light	Red
Bright	Cyan
Bright	Green
Medium	Blue
Light	Magenta
Bright	Yellow
Bright	White

## Channel Text Label

The Channel Text Label is an eight-character alphanumeric label for each displayed channel. This label is used to identify each waveform with a familiar label to aid you in recognizing signals. For example, labels such as ADDR00, DATA02, READ, and WRITE helps you to identify these signals much more easily than channel numbers alone.

The example in Figure 4-10 shows the use of Channel Text Labels.

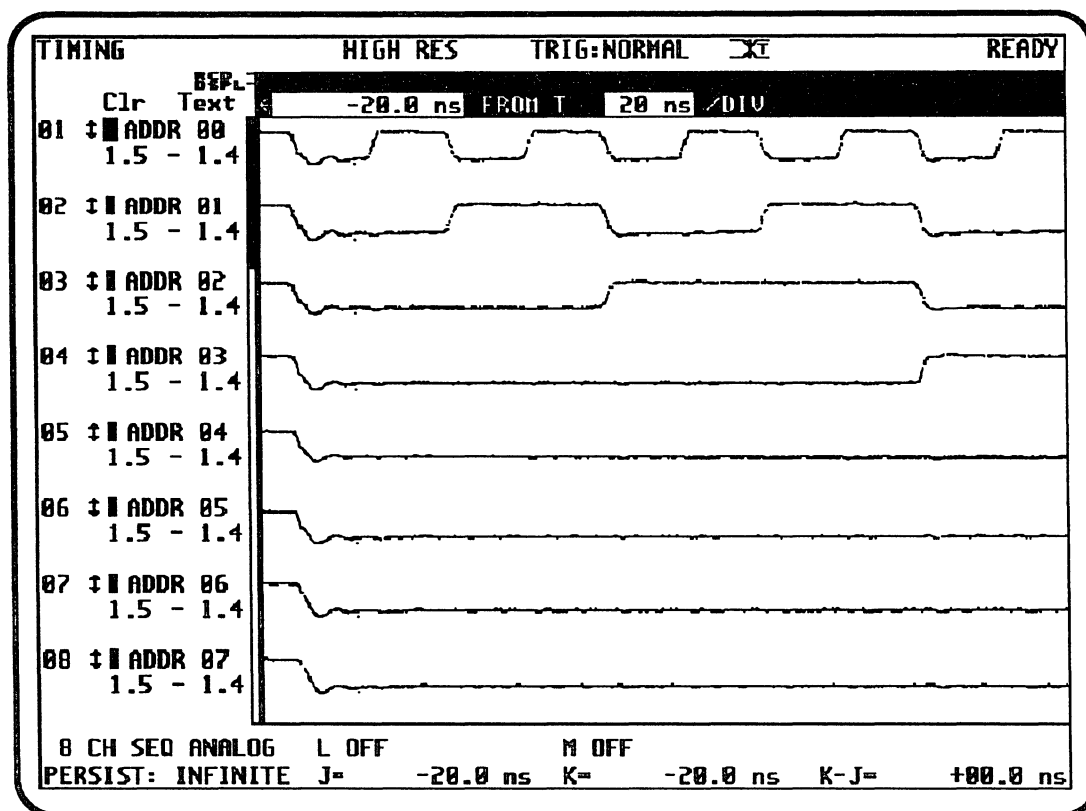

Figure 4-10. Timing Display Text Label, ADDR XX

Labels are entered by moving the blinking cursor to the desired text label field and using the keypad keys as described below:

- Numeric values are entered directly, using the number keys on the front panel.
- Letters A to Z are entered directly as second-key functions on the front panel.
- Letters are entered directly or can be selected by using the **Knob** or **Next** key to roll the displayed letter from A to Z, or by using the **Previous** key to roll the displayed letter from Z to A.
- The following characters may be entered by using the **Next** and **Previous** keys to roll from Z back to A, or from A back to Z: underline (  ), exclamation point (!), asterisk (\*), plus (+), minus (-), decimal (.), slash (/), and blank ( ).
- Insert or delete text by using the **Insert** and **Delete** keys.

Channel text labels are saved to disk when the Logic Waveform Analyzer setup parameters are saved, and when both setup and data are saved. Note that Channel Text Labels may be set for several traces at one time by using the Global Changes field of the Setup Menu.

## Channel Vertical Position

The Channel Vertical Position field is used only in overlaid mode. In this mode it is used to adjust the selected waveform up or down on the display window. The three-digit number represents pixels on the display and does not correlate to voltage values.

In use, the blinking cursor is moved to the Channel Vertical Position field on the channel to be moved. The **Next** and **Previous** keys are then used to increment or decrement the displayed value. The numeric keys followed by the **Enter** key may also be used to enter values directly into this field. This adjustment is often used to align two overlaid waveforms to aid in making precise timing measurements.

## WAVEFORM DISPLAY CHARACTERISTICS

The four fields at the lower left side of the Timing Screen determine the overall waveform display configuration. These fields are Number of Channels Displayed, Sequence or Overlay, Analog or Digital, and Infinite/Minimum Persistence time.

The example in Figure 4-11 indicates the waveform display is configured to show 8 Channels, Sequence Mode, Analog Mode and Infinite Persistence.

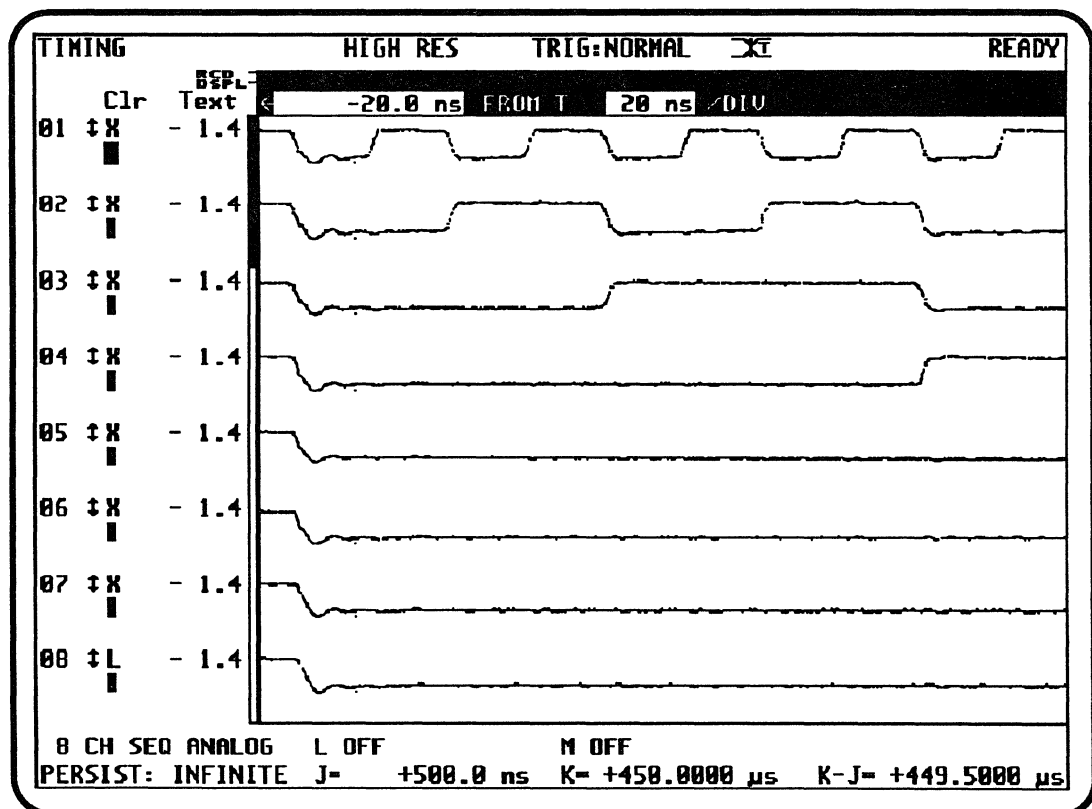

Figure 4-11. Timing Display, Waveform Selections

## Number of Channels Displayed

The value selected in this field determines the number of channels displayed. Choices are 16, 8, 4, and 2-channel modes. Reducing the number of channels by one-half doubles vertical height of the waveforms.

You may change the value in this field by using the **Next** and the **Previous** keys, or by entering the values directly with the number keys followed by the **Enter** key.

## Persistence

The Logic Waveform Analyzer features selectable persistence of the waveform display; the two choices are Minimum persistence and Infinite persistence.

In Minimum persistence, no data point (dot) stays on the screen longer than a few seconds.

In Infinite persistence, every data point (dot) placed on the screen remains there until erased by the **Clear** or **Clear/Channel** key, or if you change a value which erases the screen.

Use the **Next** and **Previous** keys to roll between the two persistence choices.

You should select the persistence mode to provide comfortable viewing of important details of the signals being observed. The effect of a value change during operation is immediately visible on the screen.

Use Infinite persistence to show intermittent or infrequent events recorded over a long time period.

## Sequence/Overlay

Use this field to display waveforms individually (each occupying its own area on the screen) or as two or more overlaid groups of waveforms. Choices in this field are as follows:

- Sequential display (displays each channel alone)
- 1 overlay (displays all channels in one overlay)
- 2 overlays (displays all channels in two overlays)
- 4 overlays (displays all channels in four overlays)
- 8 overlays (displays all channels in eight overlays)

Figure 4-12 presents an example of eight channels displayed in four overlays. If you use an external color VGA monitor, you can use different colors to identify each waveform in the overlays.

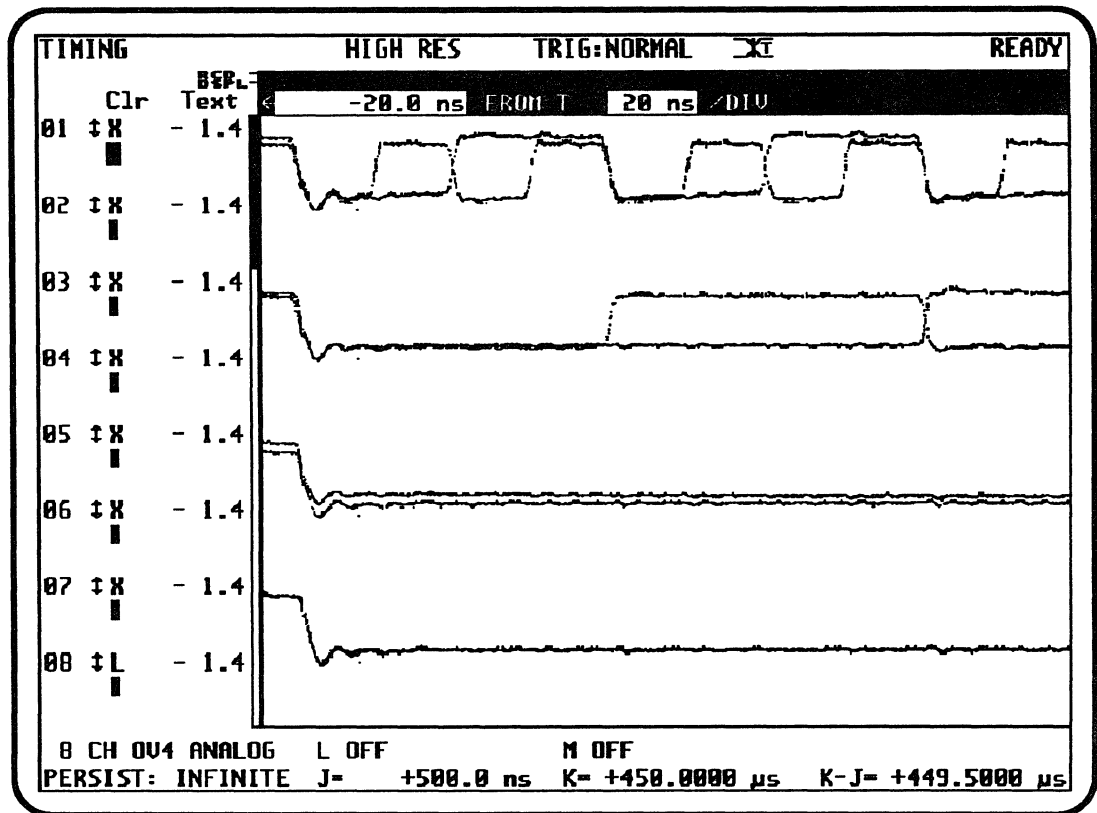

Figure 4-12. Timing Display, Waveforms with Four Overlays

## Analog/Digital Display Mode

This field determines the Analog or Digital Display Mode. In Analog Display Mode, data is displayed as analog waveforms. In Digital Display Mode, data is displayed as logic analyzer traces based on the  $V_{ih}$  and  $V_{il}$  values (see description of More Options Menu, Logic Levels in Chapter 8).

## CURSOR OPERATION

### Voltage Cursors

Two Voltage cursors (L and M) are used to measure the absolute voltages relative to ground and delta voltage of any two points on the waveform display. These cursors are turned off on power-up but may be activated at any time by moving the blinking cursor to the L or M fields and using the **Knob** or **Next** or **Previous** keys to roll the channel number from channel 01 up, or from Channel 16 down, respectively.

In use, the L and M cursors are often set to measure voltage points on the same channel but may be used on any displayed channels if desired. After selecting the desired channel for each cursor, the blinking cursor is moved to the voltage field just to the right of the channel number. With the blinking cursor at this field, the **Next** and **Previous** keys are used to move the cursor to the desired value or location, or the desired value may be entered directly using the numeric keys.

Voltage resolution of L and M cursors depends on the operating mode and number of channels displayed. If cursor movement is too small in 16-channel mode, the Number of Channels Displayed field may be used to display fewer channels on the screen, thereby making each channel taller. This makes it easier to position the voltage cursors at the exact location desired.

## Timing Cursors

Two Timing cursors (J and K) are used to measure timing values and the delta timing value of any two points on the waveform display. These cursors are displayed on power-up but may be moved off the screen if desired.

In use, these cursors are moved to points of importance on the display and the time from the trigger event to the cursor location is shown in the cursor field. A field to the right of the M cursor shows the delta time as "K-J".

Note that the cursors need not be on the display itself to measure timing differences. For example, if two points are widely separated, the displayed data could be compressed, the cursors set, and then expanded for more accurate positioning of the on-screen cursor.

## Cursor Measurements

In practice, the two sets of cursors are often used together to locate exact time and voltage points for specific points on a waveform. The L and M cursors locate the voltage points while the J and K cursors locate the timing points. The intersections of the two pairs of cursors permits more precise positioning than would otherwise be possible.

An example of specifying a timing measurement using both sets of cursors is shown in Figure 4-13.

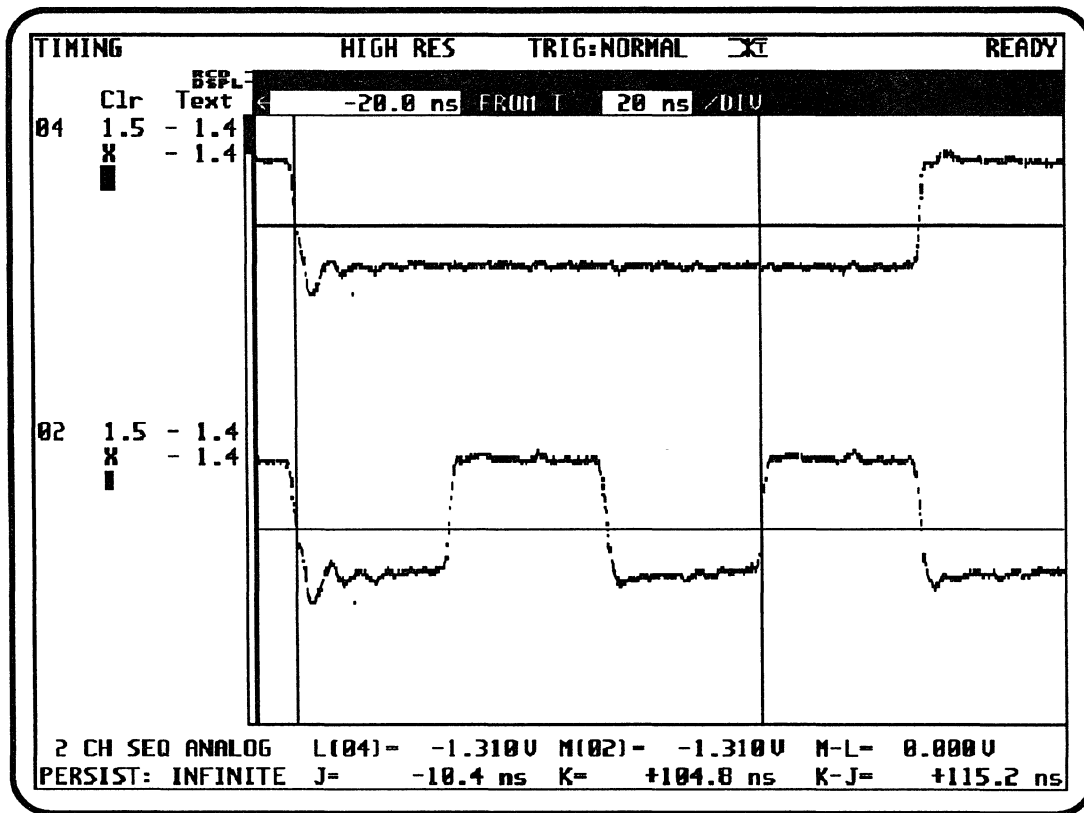

Figure 4-13. Timing Display with Voltage (LM) and Timing (JK) Cursors

# Chapter 5

## SETUP SCREEN

### OVERVIEW

#### Introduction

This chapter describes the Setup Screen which provides setup information for all channels. In addition to duplicating many of the parameter values shown on the Timing Screen described in Chapter 4, the Setup Screen also shows the Channel Trigger Level for all channels in the system, including the External Trigger, and allows you to make global changes affecting a contiguous group of channels.

Figure 5-1 shows an example of the Setup Screen.

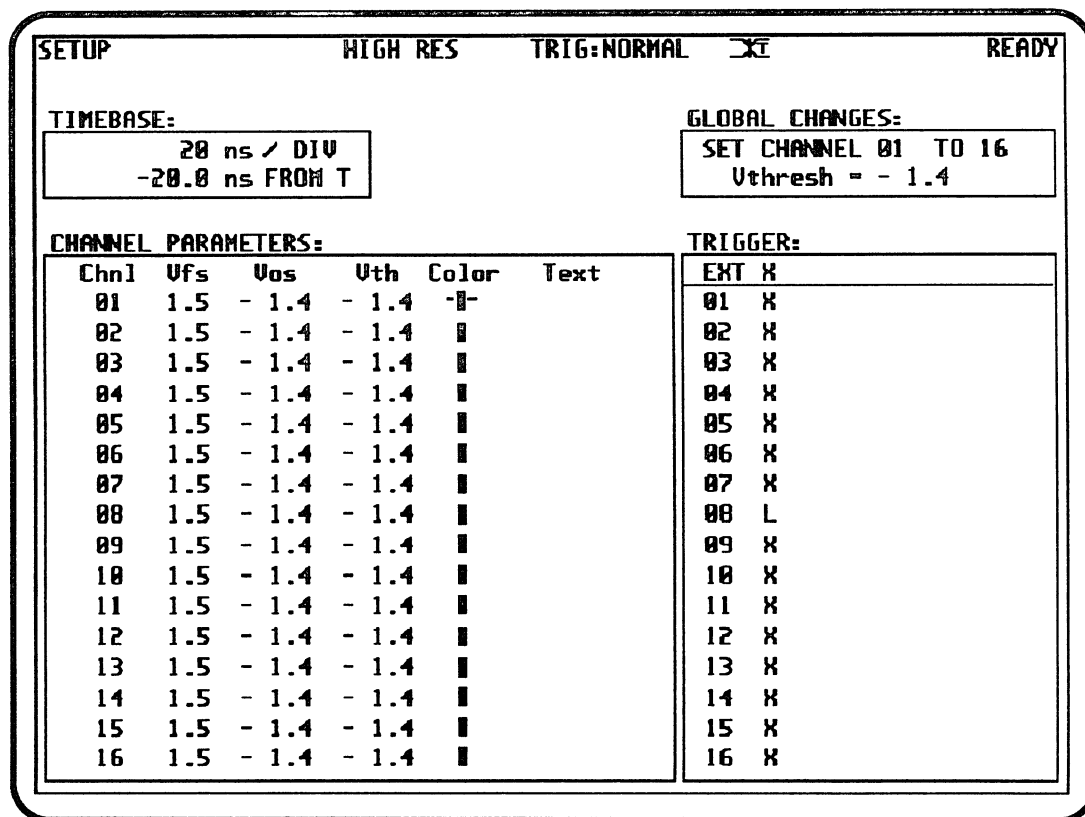

Figure 5-1. Arrangement of Setup Screen



## Autosave Feature

The K1600 Logic Waveform Analyzer contains an “Autosave” feature which saves the current setup parameters when the instrument is powered down and restores these parameters when power is reapplied. This time-saving feature sets the menus for the user, provided the test requirements have not changed since the instrument was last used.

Because of this feature, the initial screen on the unit you are using may be somewhat different from the pictures which follow. As you become familiar with the unit you will learn how to change menu parameters for your use.

## Setup and Timing Screen Interaction

The Setup Screen is interactive with the Timing Screen, therefore wherever a field is repeated on both screens a change on one screen will be reflected immediately on the other.

The description of Setup Screen contents, selection of data fields, and entering parameter values is described in subsequent paragraphs of this chapter.

## SCREEN LAYOUT

The top line of the Setup Screen duplicates fields from the Timing Screen, including Vertical Resolution, Trigger Mode, Trigger Event, and the Trigger Filter. Values in these fields may be selected from either screen; the choice is up to the user. When a choice is made on one screen, it is immediately reflected on the other screen.

The status window is displayed in the top right corner of both the Timing and Setup Screens. This field shows the Analyzer recording status at all times during normal operation.

## MENU FIELDS

### Vertical Resolution

The Vertical Resolution allows the user to select Low or High Resolution by moving the blinking cursor to this field and using the **Next** or **Previous** key to roll to the desired mode.

The High and Low Vertical Resolution described for the Timing screen in Chapter 4 is the same for the Setup Screen.

## Trigger Mode

Three Trigger Modes for Normal, Auto, and Single are provided to give the user flexibility in selecting a suitable triggering mode for each application. The mode selected determines both the waveform display as well as the resolution or detail which may be observed.

The Trigger Modes described for the Timing Screen in Chapter 4 is the same for the Setup Screen.

## Trigger Event

Six Trigger Event conditions are provided, each of which is represented by graphic symbols on the top line of the screen. These symbols attempt to show how the trigger circuitry works in each selection to guide the user in selecting the appropriate trigger event.

The Trigger Event conditions described for the Timing Screen in Chapter 4 are the same for the Setup Screen.

## Trigger Filter Qualifier

The Trigger Filter Qualifier allows the user to specify whether the Trigger Event is to be greater than (>) a specified time period or less than (<) a specified time period

The Trigger Filter Qualifier described for the Timing Screen in Chapter 4 is the same for the Setup Screen.

## Trigger Filter Duration

The Trigger Filter Duration allows the user to specify the time period required to satisfy the Trigger Event, from 5 ns to 80 ms. This wide-range time filter accommodates nearly every digital application.

The Trigger Filter Duration described for the Timing Screen in Chapter 4 is the same for the Setup Screen.

## Status Window

The far-right section of the top line shows the current status of the Analog Logic Analyzer. This window is updated continuously during operation and provides an up-to-date readout of the unit's progress through a recording sequence.

The Status Messages described for the Timing Screen in Chapter 4 is the same for the Setup Screen.

## TIME FIELDS

### Time Left Edge

This field allows you to specify the location of the first sample in memory relative to the position of the Trigger Event. By specifying this value, you determine the part of a continuous data stream which is stored in the Analyzer memory and is available for display.

The Time Left Edge conditions described for the Timing Screen in Chapter 4 is the same for the Setup Screen.

### Time Per Division

The value in the Time Per Division field determines the resolution of the displayed data. As explained above, this field is limited by the setting in the Time Left Edge field. Maximum resolution is available only when the Time Left Edge value is close to or at zero.

The Time Per Division conditions described for the Timing Screen in Chapter 4 is the same for the Setup Screen.

## CHANNEL AND DISPLAY PARAMETERS

### Channel Selection

Channel Selection for the Setup Screen duplicates the Channel Parameters displayed on the Timing Screen. The purpose of this duplication is to provide a full display of all parameters associated with the displayed channels. The channel numbers of the displayed channels are shown on the far-left side of this section.

### Channel Volts Full-Scale

There is a separate Volts Full-Scale field for each displayed channel. This field is used to set the vertical sensitivity of the Logic Waveform Analyzer, that is, the height of the displayed waveform within the space allocated for each channel display.

Like a traditional two- or four-channel oscilloscope, the separate field for each displayed channel allows the display of many signals of different voltage levels on the screen at the same time. For example, TTL and ECL signals may be displayed together, or the AC component on a power supply line together with address or data signals. The creative use of the Volts Full-Scale and Volts Offset values allows measurements which are impossible with any other instrument.

The Volts Full-Scale range is from 1.0 V to 10.0 V in 0.1 V increments.

### Channel Volts Offset

There is a separate Volts Offset field for each displayed channel. This field is used to set the position of the waveform within the space allocated for each channel display. The value displayed represents the midpoint of the allocated space for the channel displayed.

The Volts Offset field and the Volts Full-Scale field described above provide a great deal of flexibility in displaying large and small signals from -40.0 V to +40.0 V. As a general rule (or “starting point”) the Volts Full-Scale value should be set to a value slightly above the maximum peak-to-peak voltage of the signal on each channel, and the Volts Offset value should be set to the midpoint of the signal.

The Volts Offset range is from -40.0 V to +40.0 V, in 0.1 V increments.

The example in Figure 5-2 shows the Channel Volts Offset (Vos) field.

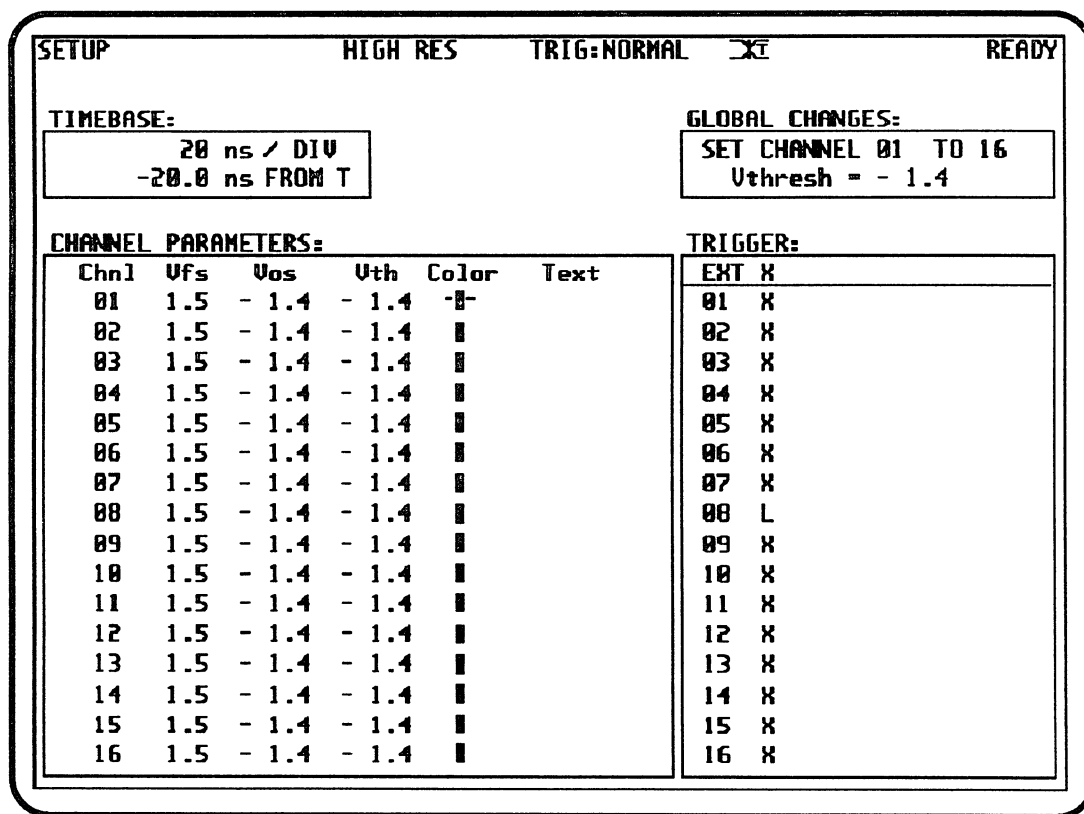

Figure 5-2. Setup Display with Channel Volts Offset (Vos) Field

### Channel Volts Threshold

The Channel Volts Threshold specifies the threshold voltage for the Channel Trigger Level described above. This is the voltage value below which the input signal is defined

as a “low” and above which the input signal is defined as a “high.” If the Channel Trigger Level is left at “X” (don’t care value) then the Channel Volts Threshold has no effect.

The **Next** and **Previous** keys are used to roll the Channel Voltage Threshold to the desired value, or the value may be entered using the numeric keys followed by the **Enter** key. The range of this field is +40.0 V to -40.4 V in 0.1 V increments. Note that this value may be changed for many channels at one time on the Global section of the Setup menu.

As a general rule, the Channel Volts Threshold value should be at the midpoint of the signal being measured on each channel. The value should be well away from any ringing or other disturbances on the line, as these could cause multiple signals to be recorded or block the correct operation of the Trigger Filter. A typical TTL threshold is 1.4 V, while a typical ECL threshold is -1.3 V.

Another use for this field is to set the Channel Volts Threshold value of one channel just above, or just below, the expected signal limits. Triggering will occur if the signal exceeds the value specified.

## Channel Trace Color

The Channel Color field allows the user to specify the color of each waveform that is presented on the Timing Screen. Using different colors for important signals helps them stand out and be easily recognized, particularly when the 16-channel mode is used. In the overlaid display, different colors are essential for separating different signals on the screen.

The Channel Trace Color selections described for the Timing Screen in Chapter 4 is the same for the Setup Screen. Table 4-2 shows the corresponding display characteristics for a built-in monochrome CRT versus the external monitor. The **Next** and **Previous** keys are used to select the waveform color choices shown in Table 4-2.

Channel Trace Colors are saved to disk when the Logic Waveform Analyzer setup files or setup and data files are saved. Note that the Channel Trace Color may be set for several traces at one time by using the Global Changes field of the Setup Menu.

## Channel Text Label

The Channel Text Label is an eight-character alphanumeric label for each displayed channel. This label is used to identify each waveform with a familiar label to aid the user in recognizing signals. For example, labels such as ADDR 00, DATA 02, READ, and WRITE helps you to identify these signals much more easily than channel numbers alone.

An example of text label use is shown in Figure 5-3.

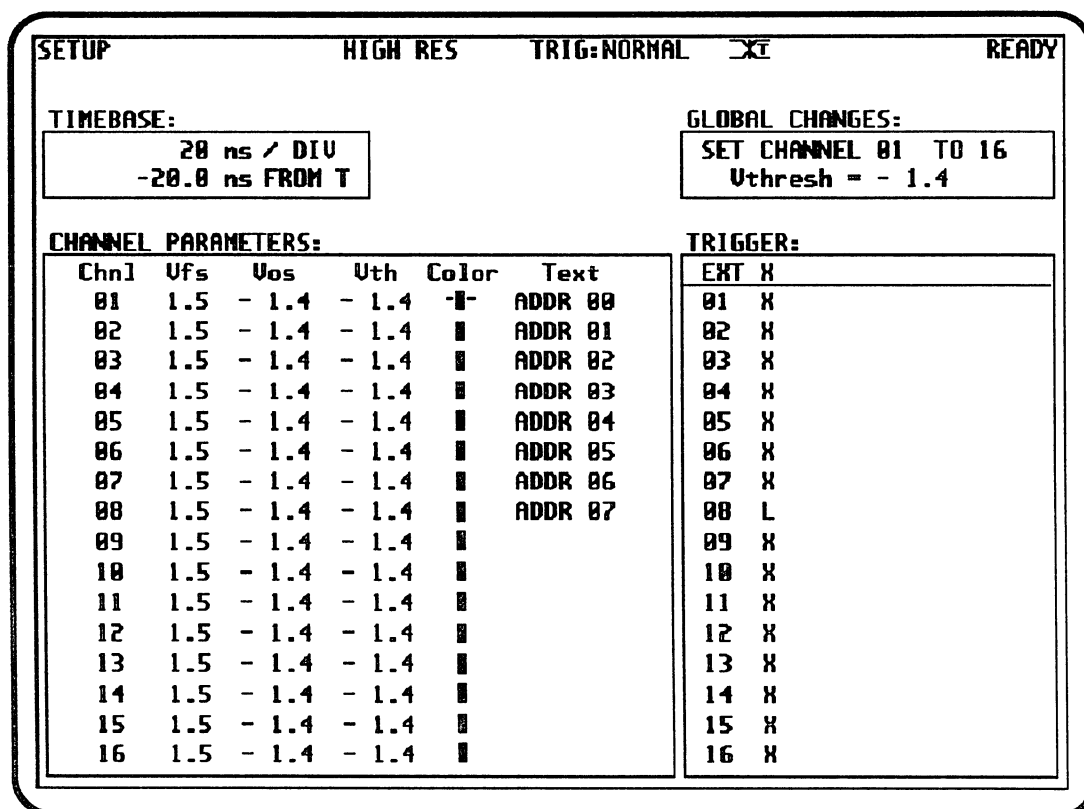

Figure 5-3. Setup Display Text Label, ADDR00-07 Selected

Labels are entered by moving the blinking cursor to the desired text label field and using the keypad as described below:

- Numeric values are entered directly, using the number keys on the front panel
- Letters A to Z are entered directly on the front panel as second-key functions.
- Letters are entered directly or by using the **Knob** or **Next** key to increment the displayed letter from A to Z, or by using the **Previous** key to decrement the displayed letter from Z to A.
- The following characters may be entered by using the **Next** and **Previous** keys to roll from Z back to A, or from A back to Z: underline ( \_ ), exclamation point ( ! ), asterisk ( \* ), plus ( + ), minus ( - ), decimal ( . ), slash ( / ), and blank ( ).
- Insert or delete text by using the **Insert** and **Delete** keys.

## CHANNEL TRIGGER LEVEL

This section of the Setup Screen displays the trigger logic level for all active channels. An example of the trigger display is shown in Figure 5-4.

SETUP		HIGH RES	TRIG:NORMAL	<input checked="" type="checkbox"/>	READY		
TIMEBASE:			Press ENTER for global set.				
20 ns / DIV			SET CHANNEL 01 TO 16				
-20.0 ns FROM T			Uglobal = ECL				
ECL 1.2 - 1.3 - 1.3							
CHANNEL PARAMETERS:			TRIGGER:				
Chnl	Ufs	Uos	Uth	Color	Text	EXT	X
01	1.5	- 1.4	- 1.4	█		01	X
02	1.5	- 1.4	- 1.4	█		02	X
03	1.5	- 1.4	- 1.4	█		03	X
04	1.5	- 1.4	- 1.4	█		04	X
05	1.5	- 1.4	- 1.4	█		05	X
06	1.5	- 1.4	- 1.4	█		06	X
07	1.5	- 1.4	- 1.4	█		07	X
08	1.5	- 1.4	- 1.4	█		08	L
09	1.5	- 1.4	- 1.4	█		09	X
10	1.5	- 1.4	- 1.4	█		10	X
11	1.5	- 1.4	- 1.4	█		11	X
12	1.5	- 1.4	- 1.4	█		12	X
13	1.5	- 1.4	- 1.4	█		13	X
14	1.5	- 1.4	- 1.4	█		14	X
15	1.5	- 1.4	- 1.4	█		15	X
16	1.5	- 1.4	- 1.4	█		16	X

Figure 5-4. Setup Display with Trigger Values X and L Specified

The Channel Trigger Level field specifies whether a channel is to be included in the overall trigger definition and what level is required to satisfy the trigger condition on this channel.

The default value in the Channel Trigger Level for each channel is an "X" (sometimes called a "don't care"), an indication that the particular channel is not part of the overall trigger definition.

An "L" is used where the voltage on the selected channel must be lower than the Trigger Threshold specified, while an "H" is used where the voltage on the selected channel must be higher than the Trigger Threshold specified.

The **Next** and **Previous** keys are used to roll the Channel Trigger Level to the desired value on each channel.

## GLOBAL CHANGES

The Global Changes section allows you to make selected changes to a contiguous group of channels rather than changing values for each channel individually. There are

four fields in the Global Changes section, Start Channel, End Channel, Global Parameter, and Global Value. These fields are described below.

### Start Channel Field

This field specifies the starting channel in the group to be changed, from channel 01 through the highest channel for which the system is configured. Values may be entered directly by using the number keys followed by **Enter**, or by using the **Next** and **Previous** keys to roll the displayed value to the desired value.

### End Channel Field

This field specifies the end channel in the group to be changed, from channel 01 through channel 16 for which the system is configured. Values may be entered directly by using the number keys followed by **Enter**, or by using the **Next** and **Previous** keys to roll the displayed value to the desired value.

Note that all channels between the Start Channel and End Channel will be affected by the Global change, including the Start and End channels.

### Global Parameters Field

This field specifies the parameters to be changed. Parameters include Trigger Level, Volts Full-Scale, Volts Threshold, Volts Offset, Color, Text Label, and Global Preset.

The **Next** and **Previous** keys are used to roll this field to the desired value.

### Global Value Field

This field allows the user to enter the desired value for the Global Parameter specified. The global value choice depends on the Global Parameter, described above.

<b>Trigger Level</b>	Choices include H, L, or X
<b>Volts Full-Scale</b>	Choices include 1.0 V to 10.0 V in 0.1 V increments
<b>Volts Threshold</b>	Choices include -40.0 V to +40.0 V in 0.1 V increments
<b>Volts Offset</b>	Choices include -40.0 V to +40.0 V in 0.1 V increments



<b>Color</b>	Choices include the following:	
	<i>Built-in CRT</i>	<i>External Color Monitor</i>
	Medium	Orange
	Light	Red
	Bright	Cyan
	Bright	Green
	Medium	Blue
	Light	Magenta
	Bright	Yellow
	Bright	White

**Text Label** You may enter any eight-character alphanumeric label

**Global Preset** Default choices are ECL, TTL, or CMOS; you may change these to any three-character alphanumeric label.

To use the Global Setup feature, follow these steps:

- Roll the Global Parameter field to `vglobal`. Move the cursor to the Global Value field (to the right of the Global Parameter field).
- Use the **Next** or **Previous** keys to roll through the available choices. The default choices are ECL, TTL, and CMOS, although these values may have been changed.
- As the screen displays each Vglobal selection, the line below to the far left of the screen displays the values for this selection. The Volts Full-Scale, Volts Offset, and Volts Threshold for the Vglobal selection appear in the same order as described in the Channel Parameters section.
- To select one of the choices displayed, roll the field to that choice and press **Enter** for Global Setup.

The Figure 5-5 example shows the Global Changes section.

SETUP		HIGH RES	TRIG:NORMAL	<input checked="" type="checkbox"/>	READY
TIMEBASE:			Press ENTER for global set.		
20 ns / DIV -20.0 ns FROM T			SET CHANNEL 01 TO 16 Vglobal = ECL		
ECL 1.2 - 1.3 - 1.3					
CHANNEL PARAMETERS:			TRIGGER:		
Chnl	Ufs	Uos	Uth	Color	Text
01	1.5	- 1.4	- 1.4	█	
02	1.5	- 1.4	- 1.4	█	
03	1.5	- 1.4	- 1.4	█	
04	1.5	- 1.4	- 1.4	█	
05	1.5	- 1.4	- 1.4	█	
06	1.5	- 1.4	- 1.4	█	
07	1.5	- 1.4	- 1.4	█	
08	1.5	- 1.4	- 1.4	█	
09	1.5	- 1.4	- 1.4	█	
10	1.5	- 1.4	- 1.4	█	
11	1.5	- 1.4	- 1.4	█	
12	1.5	- 1.4	- 1.4	█	
13	1.5	- 1.4	- 1.4	█	
14	1.5	- 1.4	- 1.4	█	
15	1.5	- 1.4	- 1.4	█	
16	1.5	- 1.4	- 1.4	█	

Figure 5-5. Setup Display for Global Selections

To change the Vglobal setup label and/or values, follow these steps:

- Use the **Next** or **Previous** key to roll the Vglobal label to an unused label.
- Use function key **F1** to move the cursor to the first character in the label on the line below.
- Use the **Next** or **Previous** keys to roll this field to the desired label character (or characters may be entered directly, using an external ASCII keyboard).
- In the Volts Full-Scale, Volts Offset and Volts Threshold fields, enter the desired value followed by the **Enter** key.
- Use function key **F1** to return the cursor to the Global Value field.

The new Vglobal label and values will be saved by the Autosave feature described earlier, and restored during power-up of the instrument.

①

②

## **Chapter 6**

# **DISK SCREEN**

---

## **OVERVIEW**

### **Introduction**

This chapter describes the K1600 Disk Screen. This screen provides access to the built-in floppy disk drive (and the optional internal hard drive, if installed).

The Disk Screen is used for saving and recalling menu setup files and/or recorded data files. The use of either disk greatly speeds up the menu setup for often-used tests. Once stored to disk, the complete menu setup file may easily be recalled at a future time for use in an identical or similar test procedure.

The Disk Screen is displayed by pressing the **Disk** key on the keypad.

An example of the Disk Screen is shown in Figure 6-1.

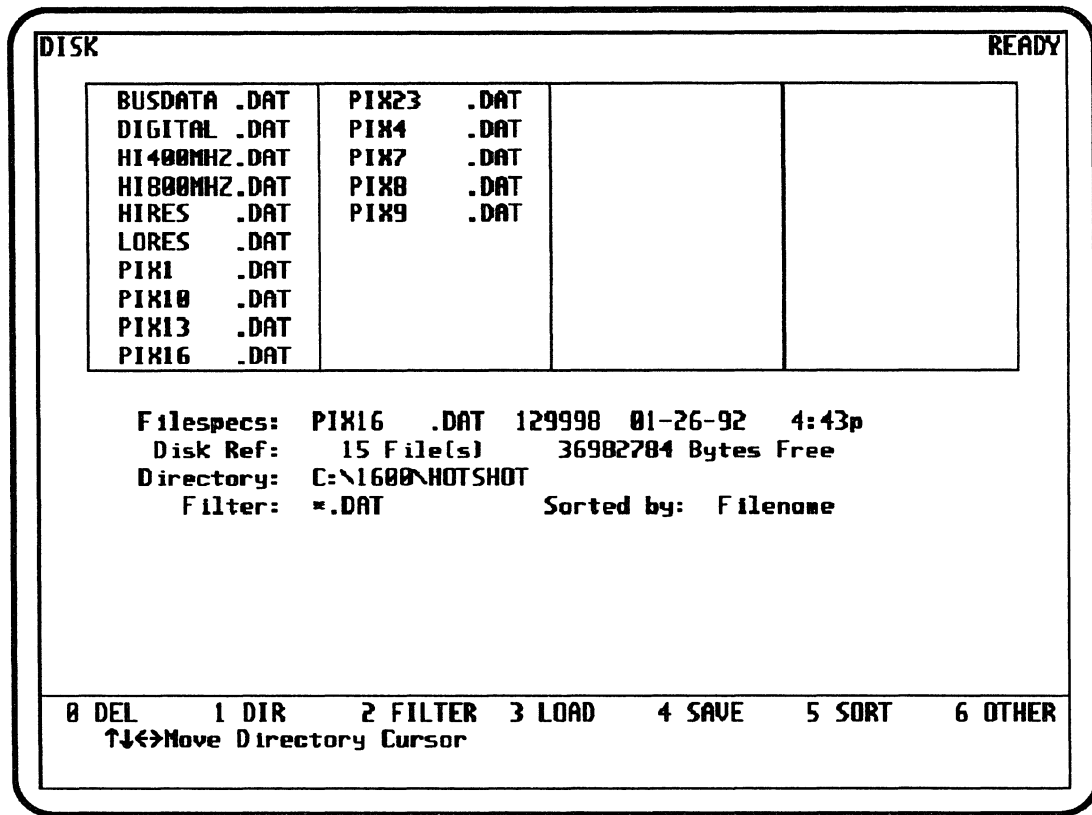

Figure 6-1. Disk Screen Arrangement

## Disk Screen Content

The Disk Screen provides the following information:

- **Disk Directory**—The top section of the Disk Screen shows a directory of all files contained in the currently loaded floppy disk. If a hard disk is also installed and selected, the directory shows the files on the directory of the active disk.
- **Filespecs**—This line located below the disk directory shows complete file information for the file highlighted by the cursor. An example of the Filespecs line is shown below.

```
Filespecs:  PIX16      .DAT  129998  01-26-92   4:33p
```

The filename, PIX16 and file extension, .DAT is created by the user when the file is saved, and is used to recall the file.

The next value shows the number of bytes used by the file, in this case, 129998 bytes.

The next two values, 01-26-92 and 4:33p, show the date and time the file was saved to disk. This date and time are taken from the Logic Waveform Analyzer internal clock.

- **Disk Ref:**—This line shows the number of files, 15 Files(s), stored on the floppy disk or hard disk, and the number of bytes, 36982784 Bytes, which are free or available for use.
- **Directory:**—This line shows the currently active directory, C:\1600\HOTSHOT.
- **Filter and Sort Order**—This line shows the filter in use (.DAT), if any. If no filter is in use, this line shows \*.\*. This line also shows the sorting order selected (Sorted by: Filename). The directory may be sorted by filename, extension, or date.
- The bottom section of the Disk Screen shows the keys that are used to perform each function. Functions provided on this screen are as follows:

<i>Key</i>	<i>Function</i>
<b>0</b>	DEL—This key allows the user to delete files from the active disk.
<b>1</b>	DIR—This key updates the displayed directory.
<b>2</b>	FILTER—This key allows the user to change the filter from its default value.
<b>3</b>	LOAD—This key allows the user to load a selected file from the active directory.
<b>4</b>	SAVE—This key allows the user to save a Setup file or Setup and Data file to the floppy disk or optional hard drive.
<b>5</b>	SORT—This key allows the user to change the sort order of the active directory.
<b>6</b>	OTHER—This key extends choices to 7 and 8 below, or back to 0 through 5, above. (When key choices 7 and 8 are displayed, the software revision number is displayed on the right side of the selection line).
<b>7</b>	FORMAT—This key allows the user to format a blank double-sided, high-density (DSHD) floppy disk.
<b>8</b>	Drive—This key allows the user to toggle between installed disk drives.

If no disk drive is installed, the directory displayed is the internal ROM files which are used to operate the unit. This directory includes includes a Default Setup File which may be used to return all menu values to their original value.

If an internal floppy disk drive is installed, key **8** is used to toggle between the internal floppy drive and the internal ROM files.

If an internal hard disk drive is installed, key **8** is used to toggle between the hard disk drive and the floppy disk drive. In this case,

the operating software and Default Setup files are contained on the hard disk drive.

## PERFORMING DISK FUNCTIONS

This section describes each disk function in detail. It may be used as a reference to provide guidance for performing any desired disk function. The order below follows the order of the prompt line at the bottom of the Disk Screen.

Please note that the disk functions described below are based on IBM DOS and MS DOS conventions. This applies especially to disk filenames and extensions, wildcard characters, and other parameters. A basic working knowledge of DOS characteristics will aid the user in performing disk functions.

### Delete A File

The zero key (0) is used to delete a file from the active directory. Files are often deleted when they are no longer needed or after they have been copied from the optional hard disk to a back-up floppy disk. Please note that a maximum of 40 files may be displayed on the screen at any time.

If the active disk or hard drive contains more than 40 files, these may be accessed by using the cursor control keys to scroll through all available files. Sorting is limited to 64 files; if the disk contains more than 64 files they may be accessed as described above but will not be sorted.

Function key F2 may be used to cancel this operation at any time.

### Update the Directory

Use the 1 key to update the displayed directory. As explained above, the directory display has a limit of 40 files. If the active floppy or hard disk contains more than 40 files the cursor control keys may be used to scroll up and down through the directory.

### Filter the Directory

Use the 2 key to select the Filter function, a convenience feature which may be used to remove unwanted files from the display without deleting them from the disk. Note that this key affects only the display, not the files contained on the floppy or hard disk.

Only three choices are allowed in this field, and are explained below.

- **All files**—This choice is selected when the asterisk (\*) is displayed in the extension part of the filename. The asterisk (\*) is used as a “wildcard” standing for any characters in this field. When the asterisk is displayed, files with all extensions will be displayed.

- **Setup files**—When you select this choice, the screen displays the word `SET` in the extension part of the filename. When selected, the screen displays only files with the extension `.SET`.
- **Data files**—When you select this choice, the screen displays the word `DAT` in the extension part of the filename. When selected, the screen displays only files with the extension `.DAT`.

Pressing the **2** key opens the filter field, allowing you to use the following keys to enter a new filter:

- Use the **Next** and **Previous** keys and **Knob** to change the displayed extension in the following sequence: `*`, `SET`, `DAT`, and back to `*`.
- Use the **Enter** key to activate the selected filter and to update the directory display.

## Load a File

Use the **3** key to load a file from the active disk. Selecting this choice opens the filename field and allows you to select the filename in one of three ways:

- By using the **Up Arrow** and **Down Arrow** keys to move the highlighted cursor to the desired filename in the directory display and pressing the **Enter** key.
- By direct entry of the desired filename using the alphanumeric keys on the built-in keypad or on the optional external ASCII keyboard. Use the **Enter** key to load the file after you have entered the name.
- By using the **Knob** or **Next** and **Previous** keys to roll the displayed character at each position to the desired character. The **Next** key rolls the displayed character from `a` through `z`, and then through several punctuation characters. The **Left Arrow** and **Right Arrow** keys move the Edit cursor left and right in the filename field. Use the **Enter** key to load the file after you have entered the filename.

You may use function key **F2** to cancel this operation at any time.

Note that data files are quite long and will require several seconds to load. During this time the following message appears on the screen:

```
Loading file...
```

If you plan extensive disk activity, an optional external ASCII keyboard (AT-compatible) is the most comfortable way to enter alphanumeric filenames.

Once the Analyzer loads a Setup or Data file, the new values are available immediately for use or modification.

The Analyzer uses several warning messages on this screen to alert you to possible problems when working with disk files:



- **Warning: Invalid file**—This message is used if the selected file is not a recognized Setup or Data file. Only setup and data files may be loaded into the model K1600 Logic Waveform Analyzer.
- **No such file or directory.**—This message is used if the named file is not present on the active disk.

## Load Default Setup File

The Default Setup File (DEFAULT.SET) is used to restore the menu fields to their original values. This file is contained on the internal ROM directory or the optional internal hard disk drive, if installed. The Default Setup is most often used when the user wants to start a new test, and finds it easier to start at the beginning rather than change each value individually. It is also useful if the unit is shared by a group of operators.

## Saving Setups and Data

Use the **4** key to save the current menu Setup and/or Setup and Data files. Pressing the **4** key opens a blank filename field and allows the user to enter the desired filename or select one of the displayed filenames. Filenames may be entered as follows:

1. By using the **Up Arrow** and **Down Arrow** keys to move the highlighted cursor to the desired filename in the directory display.
2. By direct entry of the desired filename using the alphanumeric keys on the built-in keypad, or on the optional external ASCII keyboard.
3. By using the **Knob** or **Next** and **Previous** keys to roll the displayed character at each position to the desired character. The **Next** key rolls the displayed character from **A** through **Z**, and then through several punctuation characters. The **Previous** key rolls characters in the opposite direction, from the punctuation characters back to **A**. The **Left Arrow** and **Right Arrow** keys move the Edit cursor left and right in the filename field

After the filename is entered or selected, the **Enter** key is used to accept the name and move the cursor to the File Type field.

If the filename selected is identical to a file already on the disk, the following message will be displayed:

```
Warning:  File exists.  Overwrite?  (Press F3 for Yes)
```

This alerts the user that the existing filename will be erased (overwritten) if **YES** is selected. Use function key **F2** to cancel the command if overwriting is not desired.

The File Type field allows selection of Setup or Setup and Data Files. Setup saves only the menu parameters while Setup and Data saves both the menu parameters and the previously recorded data in a single file. Selection at this field is made with the **Knob** and **Next** or **Previous** keys, which are used to roll to the desired selection. The **Enter**

key is used to execute the selection. You may use function key **F2** to cancel the selection.

## Directory Sorting

The Analyzer Disk Screen has a feature which allows you to select one of three methods of sorting the files displayed in the directory. You may sort by filename (the default value), extension, or date.

Pressing key **5** opens the `Sorted by:` field and allows you to select one of the three sort keys listed below. Select the desired key by using the **Knob** and **Next** or **Previous** keys to roll through the following choices:

- **Filename**—This choice sorts the displayed files alphabetically by filename and extension, starting with numbers 0 through 9 and continuing from **A** and ending with **Z**.
- **Extension**—This choice sorts the displayed files alphabetically by extension. There is no further sorting of files with identical extensions. This choice is often used for separating Setup files from Setup and Data files.
- **Date**—This choice sorts the displayed files by date, with the earliest files first followed by more recent files. As explained earlier, the K1600 uses the computer's internal date and time as part of the file specification included when you save a file to disk.

After the unit displays the desired choice, use the **Enter** key to execute the sort operation and update the display. Use function key **F2** to cancel the command if you do not desire execution.

## Format

This selection allows you to format a blank double-sided, high-density (DSHD) 3.5" floppy disk that you can use to store menu setups or setup and data records.

To format a disk, follow these steps:

1. Use key **8** to select the floppy disk drive as the active drive (see below)
2. Insert the blank diskette into the floppy disk drive
3. Press key **7** (Format) and watch for the following message to appear on the screen:

**Warning: Drive A: Contents will be erased.**

**Are you sure? (Press F3 for yes)**

4. If you wish to cancel the command, press **F2**.
5. If you desire erasing, press **F3** to continue. The screen will go blank for several seconds and then the following message appears:

Insert diskette to format in drive A and strike a key when ready.

Press the ENTER key to continue.

6. When formatting is complete, the following message appears:

Format another diskette: (Y/N)

Press F1 to format another diskette, or press F2 to leave the format mode and return to the disk screen.

## Drive Selection

Use key 8 to toggle between the installed disk drives as shown below:

If the optional hard disk drive *is not* installed, the unit has the the following drive specifications:

- Drive A Selects the floppy disk drive
- Drive C Selects the internal read-only ROM drive, which contains operating software

If the optional hard disk drive *is* installed, the unit has the the following drive specifications:

- Drive A Selects the floppy disk drive
- Drive C Selects the optional internal hard disk drive

The lower part of the screen displays the active drive as follows:

Directory: A:\

**NOTE:** If the Analyzer has the optional hard disk drive installed, the unit moves the internal read-only ROM directory to drive D. You may read the directory of this drive only from the DOS prompt using the optional external ASCII keyboard.

## Disk Purchase and Formatting

The built-in floppy disk drive requires high-density, 3.5" floppy diskettes. These diskettes contain a small opening opposite the write-protect slide, and are usually marked with the designation, "HD" or "High Density."

## Chapter 7

# REAR PANEL

---

## OVERVIEW

### Introduction

This chapter describes the K1600 rear-panel components. These components include the following controls and connectors, which Figure 7-1 shows.

- **Intensity Control**—Used to adjust brightness of the built-in VGA display
- **Channel Probe Connectors**—Provide interface for channel inputs
- **Keyboard Connector**—Allows the connection and simultaneous use of an optional, external ASCII keyboard along with the built-in keypad
- **Video Output Connector**—Allows the connection and use of an external VGA color display monitor.
- **RS-232 I/O Connector**—Used for serial printer output to obtain hardcopy of recorded data
- **Trigger Input BNC Connector**—Allows you to use an external signal as a Trigger Event
- **Trigger Enable Input BNC Connector**—Allows you to use an external signal as a Trigger Enable
- **Qualified Trigger Output BNC Connector**—Provides an output signal whenever the input signals from all units match the specified Trigger Logic Level Pattern and Filter
- **System Trigger Output BNC Connector**—Provides an output signal whenever the K1600 halts data input and displays recorded data on the CRT
- **Buffered Data Output Connectors**—Provides buffered copies of all input signals and the external trigger and external clock signals
- **Calibration Connector**—Used for factory calibration of all input channels
- **Parallel I/O Connector**—Provides interface for parallel printer to obtain hardcopy of recorded data
- **5 V LEMO Connector**—Provides +5 V and -5 V power for external level converter with different levels for external trigger

- **AC Power Connector**—Accepts universal AC voltage levels of 90 to 240 volts, 50 to 60 Hz, 350 watts
- **800 MSample Probe Connectors**—Provides interface for optional 800 MSample Probe accessory (described in Chapter 9)
- **GPIB (IEEE-488) I/O Connector**—Provides optional GPIB interface to the user's GPIB host controller
- **Cooling Fans**—Dissipate accumulated heat from inside chassis

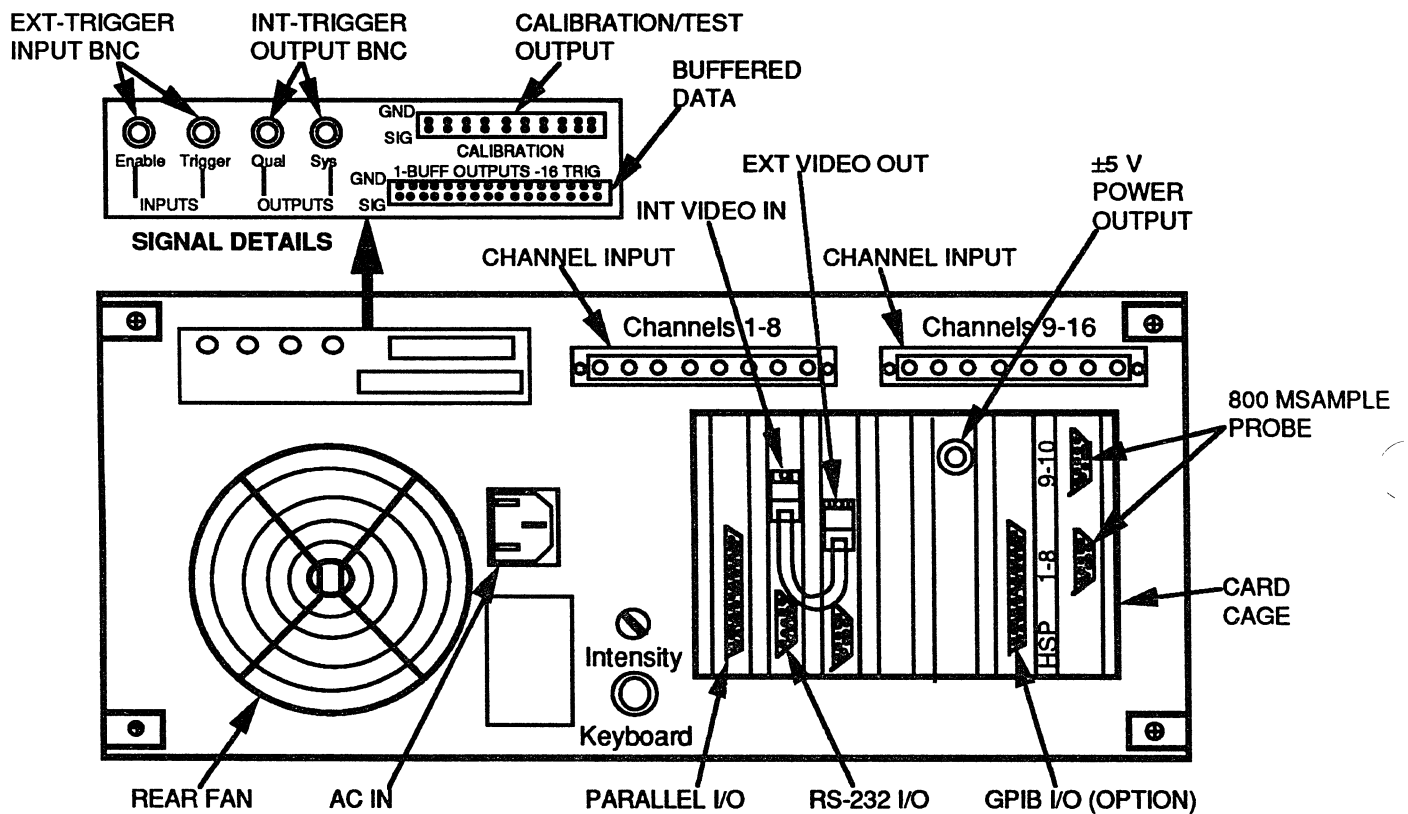

Figure 7-1. K1600 Rear Panel Components

## INTENSITY CONTROL

The Intensity Control is used to adjust the brightness of the built-in VGA display. This is the only user control provided for the VGA display. All other display adjustments are internal and should be made only by a factory-trained technician.

**WARNING:** Electrical shock may result if the chassis covers are removed to make internal adjustments to the display.

## KEYBOARD CONNECTOR

The Keyboard Connector allows the user to connect an optional, external keyboard to the Logic Waveform Analyzer. The external keyboard is convenient when many alphanumeric labels are used to identify traces on the Timing Screen and when extensive use is made of Setup and/or Setup and Data files that are saved and recalled from the floppy disk or optional hard disk drive.

Any AT-compatible ASCII keyboard may be used with the Logic Waveform Analyzer provided it has a standard round, five-pin keyed connector. Switchable or self-configurable XT/AT keyboards may also be used as long as they are supplied with the correct connector.

Table 7-1 shows the equivalent key entry when an external keyboard is used. Note that the external keyboard does not disable the built-in keypad. Both the keypad and keyboard are active at all times, and may be used interchangeably for K1600 operation. This is a special convenience for the user who prefers using the built-in keypad for some functions and the external keyboard for others.

**Table 7-1. Keypad Versus ASCII Keyboard Entry**

<i>Keypad Entry</i>	<i>ASCII Keyboard Equivalent Entry</i>
0-9, A-Z	0-9, A-Z
-	-
.	.
Enter	Enter
ms	m or M
us	u or U
ns	n or N
up/down/left/right	up/down/left/right
Next	PgUp
Previous	PgDn
Start	F6
Stop	F5
Clear/Channel	Shift-F7
Clear	F7
More	F8
Help	F9
Menu	F10
F1	F1
F2	F2
F3	F3
F4	F4
Page Up	Ctrl-PgUp
Page Dn	Ctrl-PgDn
Scroll Up	Ctrl-U
Scroll Dn	Ctrl-D
Disk	Alt-D
Setup	Alt-S
Timing	Alt-T
Print	Alt-P
Insert	Ins
Delete	Del
Space	Space

## VIDEO OUTPUT CONNECTOR

A nine-pin, D-type connector mounted on the rear panel is used to provide video signals to the internal monochrome display or an external VGA color display. When the

internal display is used, a short jumper cable takes the signal from the Video Output Connector and returns it to the Video Input Connector.

An external display may be used together with an external keyboard for distant operation of the instrument (several feet away from the unit, for example) or for large-group viewing of the screen. Please note that the output is *not* compatible with EGA or other color monitors which do not meet the VGA signal specifications and requirements.

## TRIGGER CONNECTORS

### Trigger Input

The Trigger Input BNC Connector provides an input for an external hardware trigger signal, which may be used alone or in combination with trigger bits set on any combination of data input channels. This TTL edge-sensitive input provides an important resource in critical triggering situations.

### Trigger Enable Input

The Trigger Enable Input BNC Connector provides an additional triggering resource in critical applications. This TTL-level input may be used to inhibit triggering until an external signal enables the internal trigger circuitry. A low level inhibits triggering, while a high level permits triggering on the next qualified event. This input is active whenever the Logic Waveform Analyzer is in the Running Mode.

### Qualified Trigger Output

The Qualified Trigger Output BNC Connector provides a positive TTL-level output signal whenever the combined combinational trigger signal from the unit matches the logic levels and filter values specified. This signal may be used for synchronization or other purposes. This output is active at all times.

### System Trigger Output

The System Trigger Output BNC Connector provides a positive TTL-level output signal whenever the unit halts recording and displays recorded data on the CRT. This signal may be used for synchronization or other purposes. This output is active at all times.



## BUFFERED DATA OUTPUT CONNECTORS

### Signal Connections

The Buffered Data Output Connector provides a copy of the 16 data inputs to the model K1600. These outputs relieve the user of “double-probing” signal points on the unit under test in cases where another instrument must be connected to the same point as the Logic Waveform Analyzer. This greatly simplifies the connection to a crowded device or board under test and reduces the loading which would occur when two probes are connected to the same signal point.

The Buffered Data Output signals are isolated from the input probe but are not clocked or modified in any way. As such, they faithfully duplicate the signals being probed with only a slight delay caused by the active buffer and coaxial cable in the signal path.

### Using Buffered Output Signals

One important use for the buffered data output signals is the use of a “state” logic analyzer with multiple trigger levels and other trigger resources. By combining the trigger resources of the Logic Waveform Analyzer with those of an additional “state” logic analyzer, you have almost unlimited trigger resources at your command.

In addition to the buffered data outputs described above, a copy of the External Trigger Input (described in Trigger Connections) is also provided on the rear panel. This External Trigger Input may be used like the buffered data outputs described above in order to avoid double-probing, or to allow the use of another instrument at the same time the Logic Waveform Analyzer is in use.

## OTHER CONNECTORS

### GPIB Connector

The optional 24-pin, IEEE-488 Connector is used to permit remote operation of the K1600 from a GPIB host controller. This operation is most often used in ATE applications or other situations where automatic control of the unit is required.

The GPIB interface allows the user to control most functions of the K1600 remotely from the IEEE-488 instrument bus. Furthermore, it provides for the transfer of ASCII data to other GPIB compatible devices. The GPIB interface provides full remote control, supporting Talk/Listener mode for controlling the K1600 in a test environment with your GPIB host controller.

When operated by an external GPIB host controller, all menu parameters may be entered, the unit armed, and recorded data transferred to the controller for analysis or other use.

## RS-232 Serial Connector

The nine-pin, D-type socket I/O connector is used to provide output to a serial printer or plotter. The setup of parameters and protocol for using this interface is described in Chapter 8.

## Parallel (Centronics) Connector

The 25-pin, D-type socket I/O connector provides the parallel interface for operation of the user's parallel printer.

## COOLING FANS

There are two cooling fans on the model K1600, one on the left side of the unit and the other on the rear panel. These fans draw air into the unit through ventilation holes on both sides of the unit and vents heated air from the rear panel.

**CAUTION:** Both the intake holes and the cooling fans must never be obstructed while the unit is operating as this will reduce airflow through the unit and could result in overheating and internal damage.

If the unit is mounted in a rack or other enclosure, ensure that enough clearance is provided to obtain sufficient intake and output airflow. Biomation will not accept responsibility for units damaged by overheating due to insufficient airflow through the unit.

## AC INPUT CONNECTOR

The AC power input connector accepts the standard plug on the end of the power cord supplied with the unit. The K1600 Logic Waveform Analyzer is self-selecting for operation at 90 to 240 VAC and 50 to 60 Hz. The internal power supply will sense the input voltage/frequency level and configure the unit for operation at the required level. No internal or external adjustments are required when changing from 110 to 220-volt power sources.

The power consumption for a fully-configured K1600 is 350 watts. A built-in fuse block (not accessible to the user) provides protection for power overload.

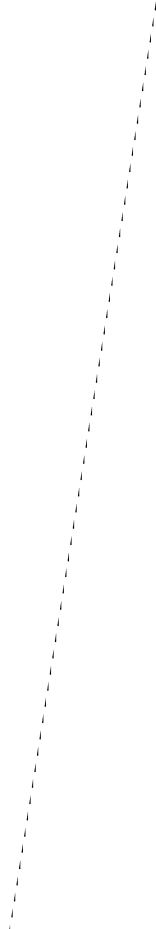

## **Chapter 8**

# **SPECIAL OPERATING FEATURES**

---

## **OVERVIEW**

### **Introduction**

This chapter describes the K1600 special operating features which are not included elsewhere in this manual. These features include using the More Option Menu to set up I/O Operations, Select Probe Type, Store Display Content in Reference Memory, Clear Reference Memory, Display Logic Levels, and Define Stop Conditions for Trigger Events during analysis. A description of the Print Function is also provided.

## **MORE KEY MENU**

Use the **More** key to display a pop-up menu screen which provides access to several additional Analyzer functions without requiring a dedicated front panel key for each function.

Figure 8-1 shows an example of the More Options pop-up menu.

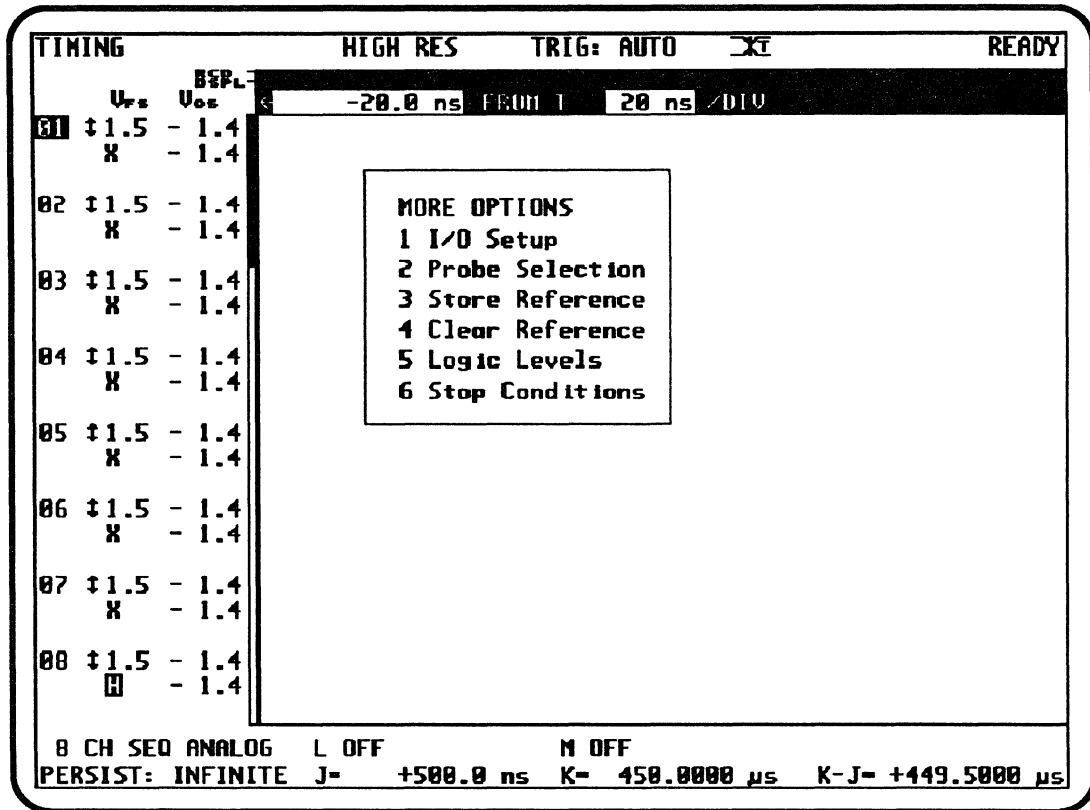

Figure 8-1. More Key Pop-Up Menu

At the present time there are six choices available on the More Options Menu, but more functions may be added in the future. Each menu item is selected by pressing the assigned key number.

## I/O Setup Menu

Pressing key 1 on the More Options Menu displays the I/O Setup Menu. This menu allows the user to define parameters for printing files and other I/O functions.

You can select a serial or parallel printer as the destination output device along with the source filename. The required RS-232 parameters and protocol can be specified on the I/O Setup Menu. You can also specify the Device Address assignment for GPIB operations with a host controller.

An example of the I/O Setup Menu is shown in Figure 8-2.

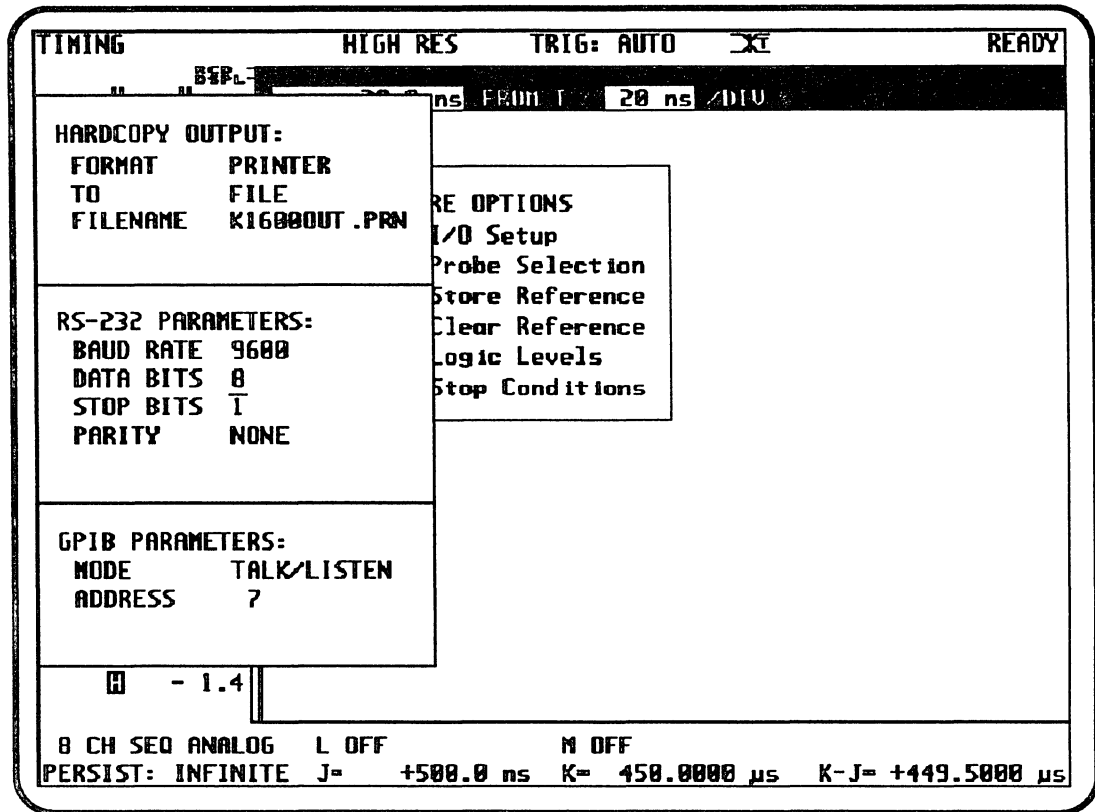

Figure 8-2. More Key, I/O Setup Menu

## Probe Selection Menu

Pressing key 2 on the More Options Menu displays the Probe Selection Menu. This menu allows you to select standard probes or the optional 800 MSample Probe for each input channel group. Chapter 9, Options and Accessories, describes the 800 MSample Probe.

## Store Reference Memory Function

Pressing key 3 on the More Options Menu selects the Store Reference Memory function. This function allows you to store contents of the display memory in internal RAM memory. The unit then displays the stored data for reference or comparison purposes. The screen displays the stored data as a shaded trace (or in yellow with a color monitor), and will remain on the Timing Screen until cleared as explained below.

Note that the Analyzer stores the reference memory in its volatile RAM memory, and will be lost when the power is turned off.

If you require permanent data storage, you may use the Disk Screen to save the desired setup and data to disk. When display is required, the Setup and Data file may be re-

trieved from the disk and stored in volatile RAM memory using the procedure described above.

### Clear Reference Memory Function

Pressing key 4 on the More Options Menu selects the Clear Reference Memory function. This function is used to clear the displayed reference memory. Once cleared, the Timing Screen will be clear until new data is recorded using the **Start** key.

Please note that no provision is made for saving reference data to disk, recalling reference data from disk, or for copying reference data to "main memory." To save a reference recording, the file must be saved prior to copying the recording to reference memory.

### Logic Levels Menu

Pressing key 5 on the More Options Menu displays the digital Logic Levels Menu.

The example of Figure 8-3 shows the Logic Levels Menu.

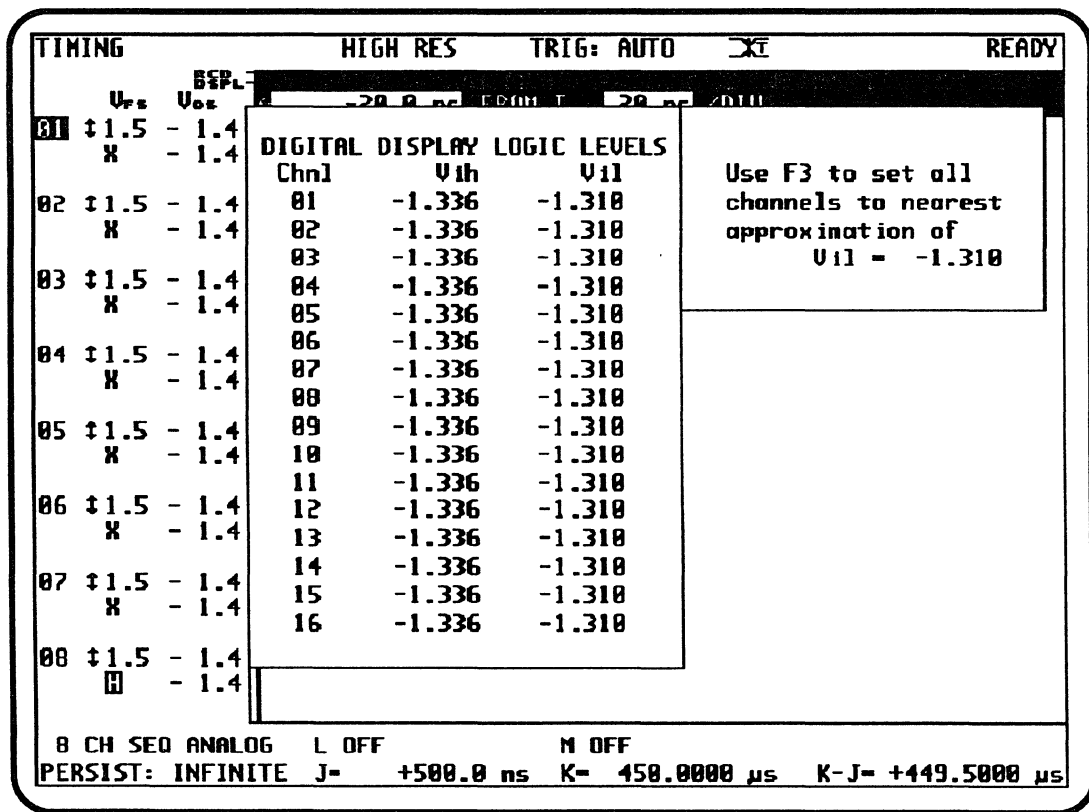

Figure 8-3. More Key, Logic Levels Menu

The K1600 Logic Waveform Analyzer is similar to a digital logic analyzer in that it samples input signal voltages at fixed time intervals and stores the digitized signal in a high-speed memory.

## Logic Levels Description

Where a digital logic analyzer stores each sample as a single bit indicating a high or low logic state, the K1600 stores the sampled voltage as a four-bit or six-bit value. For many applications, this is more resolution than you would need. You would often like to distinguish between only three levels as follows:

- Valid Logic Lows (Vil),
- Valid Logic Highs (Vih),
- Threshold Levels in the transition region between the Valid Low and Valid High state.

To convert analog signals into digital states, it is necessary to define logic thresholds. The Time Chart Display in the Timing Screen allows you to define two thresholds on a channel-by-channel basis as follows:

- Vil, below which the signal is a valid low;
- Vih, above which a signal is a valid high.

The Analyzer defines transition region to be the range of voltages from Vil to Vih. If you program Vil and Vih to be equal, no signals will be in the transition region and all signals will be either high or low.

## Vil and Vih Logic Transition

The Analyzer does not allow you to program Vil to be greater than Vih. Define the thresholds from the Logic Levels pop-up menu, which you access with the key sequence **More, 5**.

Use the **Next** and **Previous** keys or direct entry keys to assign a voltage value within ranges for each Logic Level as shown in Table 8-1.

On every channel, the menu software forces each threshold voltage to match one of the digitization boundary voltages for that channel. This section describes the evaluation of the boundary voltages.

These voltages are determined by the programmed Voffset, Vfullscale for that channel. The voltages are also affected by the recording resolution mode. In low-resolution recording mode, there are 16 levels recorded. The 16 levels are separated by 15 boundary voltages. In high-resolution recording mode, there are 60 levels recorded, which are separated by 59 boundary voltages.



Table 8-1. High and Low Logic Levels

Low-Resolution Voltage Ranges		High-Resolution Voltage Ranges	
Level 16	(V15 < Vin)	Level 60	(V59 < Vin)
Level 15	(V14 < Vin < V15)	Level 59	(V58 < Vin < V59)
Level 2	(V01 < Vin < V02)	Level 2	(V01 < Vin < V02)
Level 1	(Vin < V01)	Level 1	(Vin < V01)

### Stop Conditions Menu

Pressing key 6 on the More Options Menu displays the Stop Conditions Menu.

The example in Figure 8-4 shows the Stop Conditions Menu.

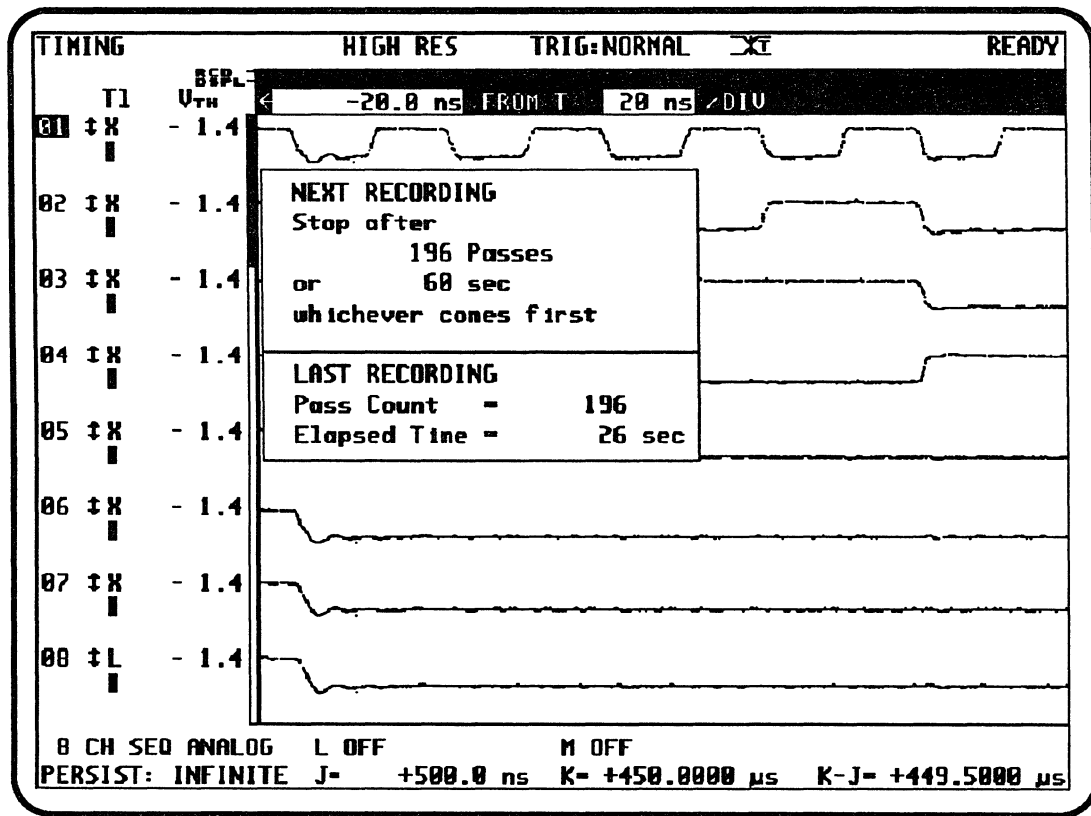

Figure 8-4. More Key, Stop Conditions Menu

The Stop Conditions Menu allows you to enter a value for the number of occurrences (passes) of the trigger event and/or a value for a specified number of seconds. When one or both of these values are entered the Logic Waveform Analyzer will record and display data until either of the limits is reached, and will then stop. This is useful where the user wants to record and display a predetermined number of events (as defined by the trigger event) or record and display for a preset number of seconds.

When a value is entered into either the events or seconds field, the unit will display in the status window (upper-right-hand corner of the Timing and Setup Screens) the number of events recorded up to the time the unit has stopped. This value is also displayed on the Stop Conditions Menu, which may be called up again by pressing the **More**, **6** keys.

## TIME CHART DISPLAY

The Time Chart Display is a software feature, provided in the K1600 Timing Screen. This display presents analog data in the form of digital logic analyzer timing traces. The Time Chart Display feature is selected by the `ANALOG/DIGITAL` field, which is located near the lower-left corner of the Timing Screen.

The `ANALOG` choice selects normal Logic Waveform Analyzer operation, while the `DIGITAL` choice selects the Time Chart display mode.

With `DIGITAL` selected, the `SEQUENCE/OVERLAY` field determines whether the display consists of sequential timing traces representing single channels or bus traces representing groups of channels.

The Time Chart Display screen presents samples containing valid levels as low or high lines. A high line indicates that the signal is above  $V_{ih}$ ; a low line indicates that the signal is below  $V_{il}$ . There is no provision for inverting the signal. Samples containing levels in the transition region are displayed as shaded areas. In keeping with the logic analyzer display, the transitions between levels are joined with vertical lines.

Due to the use of persistence, some samples may be found to have been valid lows on some recordings and valid highs on others. If these samples do not contain data points in the transition region, the display presents two lines, one low and one high. The occurrence of any data points in the transition region cause the sample to be displayed as a shaded region. These rules support the display of "eye-patterns" in which stable intervals can be distinguished from intervals in which signals are changing.

## TIME CHART BUS DISPLAY

To the left of the `ANALOG/DIGITAL` field is the `SEQUENCE/OVERLAY` field, which is used to select the Overlaid Trace Display mode. When Overlaid Trace Display mode is combined with Time Chart Display mode, the screen becomes a digital bus display. As in analog mode, the display can consist of the following conditions:

- `ov1`      1 bus of 2, 4, 8, or 16 channels each.
- `ov2`      2 buses of 2, 4, or 8 channels each.
- `ov4`      4 buses of 2 or 4 channels each.
- `ov8`      8 buses of 2 channels each.

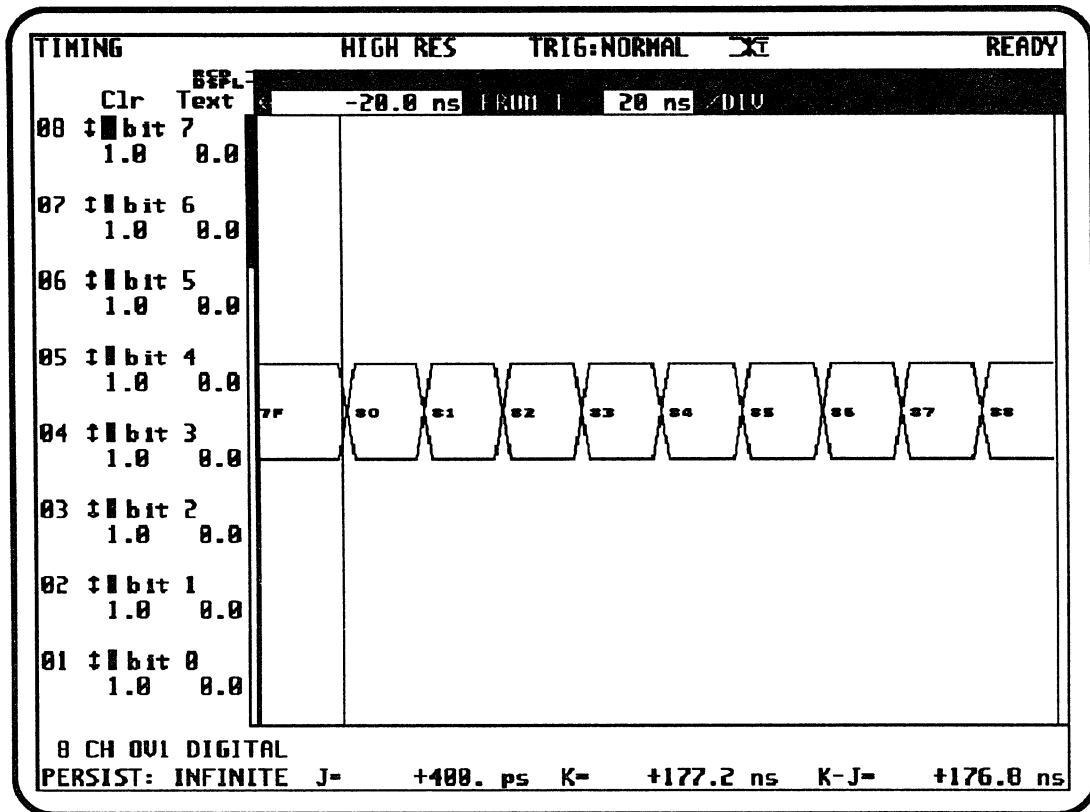

Figure 8-5. Time Chart Bus Display

The bus display is created according to the following algorithm:

Samples at which all channels are valid logic levels are displayed as two lines representing the fact that the bus can contain both high and low levels. Note that both lines are drawn even when all channels are high, or when all channels are low. That is, the high and low lines are used only to indicate the bus is stable, not that the bus is actually a mix of high and low signals.

Samples at which any channel is in the transition region is represented as a cross-hatch. A cross-hatch is also displayed when the state of the bus changes from one sample to the next, regardless of whether any data points are captured in the transition region. Due to the use of persistence, some samples may be found to have been valid lows on some recordings and valid highs on others. These samples are also displayed as a cross-hatch.

Where the bus is stable, the state of the bus is drawn in as one or more digits, with the format depending on the number of channels in the bus as shown in the following examples:

- 2 channels            1 base-4 digit            (0, 1, 2, or 3)
- 3 channels            1 octal digit            (0 through 7)

4 channels	1 hexadecimal digit	(0 through 9, A through F)
8 channels	2 hexadecimal digits	
6 channels	4 hexadecimal digits	

The numeric value is formed by designating the topmost channel in the sequence as the most significant bit. Each lower channel in the sequence is treated as a less significant bit. Where blanks appear in the sequence, the corresponding bit location is assigned a zero value.

As an example, assume that the Timing Screen is set up for eight channels as two overlays in digital mode (8 CH OV2 DIGITAL). If the sequence from top to bottom is set to channels 01, 02, 03, 04, 05, 06, 07, and 08; then the upper bus represents channels 01, 02, 03, and 04 and the lower bus represents channels 05, 06, 07, and 08. The state labels on the upper bus are single hexadecimal digits in which the most significant bit is the value of channel 01 and the least significant bit is the value of channel 04.

## HARD COPY OUTPUT

The top section of the More Options, I/O Menu (Figure 8-2) allows you to select the location of the hardcopy output. Present selections are FILE, RS-232, and PARALLEL.

### FILE Selection

The FILE selection allows the user to specify a filename for directing encoded output to a file on the active disk drive (the floppy disk drive or the optional hard disk drive). The filename is entered by the user and has the fixed extension PRN. If no filename is entered, the default filename 1600OUT.PRN will be used.

Using the FILE selection allows very fast saving of multiple screen images, and makes it possible to print the images unattended using a batch file running on an external computer.

### RS-232 Port Selection

The RS-232 selection directs the encoded data out the RS-232 serial connector on the rear panel. This allows an Epson or Epson-compatible serial printer to be connected directly to this port for immediate printing whenever desired. Although slower than sending the data to a file, this method results in an immediate hardcopy printout of the screen image.

Many users purchase a low-cost dot matrix printer for dedicated use with the Logic Waveform Analyzer. This can be kept with the unit at all times, even when the unit is used on a "scope cart" or other mobile unit.

## RS-232 Parameters

The lower section of the I/O Menu provides fields for entering setup parameters for the RS-232 serial port. User-selectable parameters are shown in Table 8-2. Parameters may be selected by using the **Next** or **Previous** keys to roll through the available choices, or by using the number key shown to the right of the parameter value.

**Table 8-2. RS-232 Parameter Selections**

<i>Parameter</i>	<i>Value (Selection Key)</i>	
Baud rate	110	(0)
	150	(1)
	300	(2)
	600	(3)
	1200	(4)
	2400	(5)
	4800	(6)
9800	(7)	
Data bits	7	(0)
	8	(1)
Stop bits	1	(0)
	2	(1)
Parity	None	(0)
	Odd	(1)
	Even	(2)

You may connect a serial printer with a 25-pin input port to the 9-pin RS-232 serial port of the K1600 by using a 9-pin to 25-pin cable adapter. The adapter cable must have the pin-to-pin connection as shown in Figure 8-6. Standard cable adapters with the required pin connections may be available.

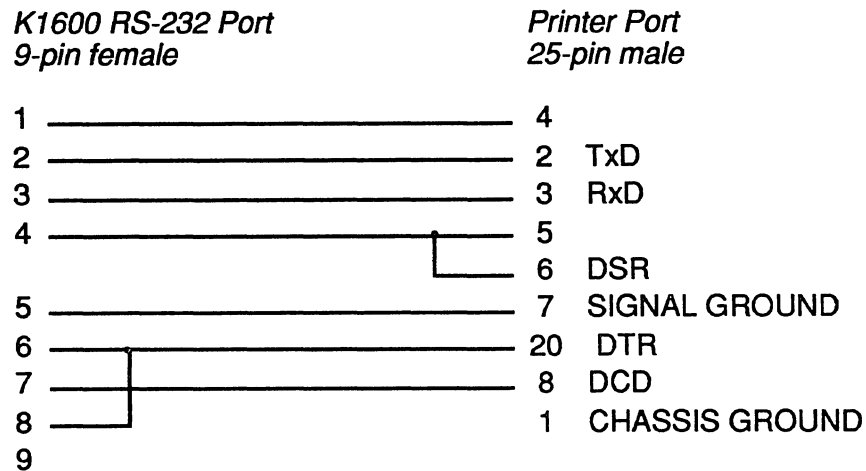

Figure 8-6. Nine-pin to 25-pin Cable Connections Diagram

## PARALLEL Port Selection

The PARALLEL selection directs encoded data out of the parallel connector on the rear panel. This allows an Epson or Epson-compatible parallel printer to be connected directly to this port.

## GPIB Parameters

The bottom section of the I/O Menu provides fields for entering setup parameters for the optional GPIB port. The user can assign the Device Address Number from 0 through 30. The default address is 7. The GPIB option is fully-described in Chapter 10.

# PRINT FUNCTION

## Print Screen Contents to Printer

The **Print** key directs an encoded copy of the displayed screen to the device selected on the I/O Menu described above. The encoded data is used to print an exact copy of the displayed screen including both waveforms and displayed menu parameters. At the present time, the encoding is limited to Epson or Epson-compatible graphics printers, such as the Epson FX-100. Printing time depends on the speed capability of the printer, and may take a minute or longer for each screen.

If RS-232 is selected on the I/O Menu, the print information is sent directly to a serial printer connected to the RS-232 connector on the rear panel.

If PARALLEL is selected on the I/O Menu, the print information is sent to a parallel printer connected to the parallel port on the rear panel.

## Print Screen Contents to File

If FILE is selected on the I/O Menu, the print information is sent to a file on the active disk drive, using the filename entered on the I/O Menu. If no filename is selected, the default filename of 1600OUT.PRN will be used. The FILE selection has the advantage of being much faster than the printer, and allows unattended batch file printing of many screen images at a later time.

## Print Procedure

Use the following steps to perform the print function:

- Use the I/O Menu to select the desired output, and the appropriate filename if FILE is selected (see below).
- If RS-232 or PARALLEL is selected, ensure that the appropriate serial or parallel printer is connected, turned on, and "on line."
- Make any changes to the display that should appear on the final print.
- Press the **Print** key. If FILE is selected, the encoded data will be written to the active drive using the filename selected above. If RS-232 or PARALLEL is selected, printing will start immediately on the printer.
- The **Stop** key may be used to stop printing at any time, or in the event that no printer is connected to the unit. The user should allow 10-15 seconds for the stop command to be executed.
- After writing to disk or when printing is completed, the unit will return to its normal operation.
- If FILE was selected, use the I/O Menu to select a new filename for the next print operation.

## Printing Files From External PC

Since the floppy disk format is PC-compatible (IBM DOS format), an external PC may be used to print files saved on a floppy disk in picture format (using the save-to-file function described above).

Insert the floppy disk containing the desired files into the PC and type the following command:

```
COPY A:<filename.PRN> LPT1/B <ENTER>
```

**NOTE:** The /B at the end of the command line is required to identify the file as a binary file.

## **Chapter 9**

# **OPTIONS AND ACCESSORIES**

---

## **OVERVIEW**

### **Introduction**

This chapter describes the following options and accessories which are available for the model K1600 Logic Waveform Analyzer:

- 800 MSample Probe (Product Number A16000)
- Internal 40 Mbyte Hard Disk Drive (Product Number K1600-Opt2)
- External ASCII Keyboard (Product Number K1KBD)
- GPIB Control (Product Number A16004)

Please contact your local Biomation sales representative for information about purchasing any of these options or accessories.

## **800 MSAMPLE PROBE**

The optional 800 MSample Probe provides single-shot sample rates up to 800 Msamples/sec on one channel or 400 Msamples/sec on two channels. The probe consists of a small pod with two probe tips and two attached cables. One cable is for channel input connections; the other cable is for power and control connections. You may use up to two pods with the K1600.

Figure 9-1 shows details for connecting the 800 MSample Probe to the K1600 rear panel.



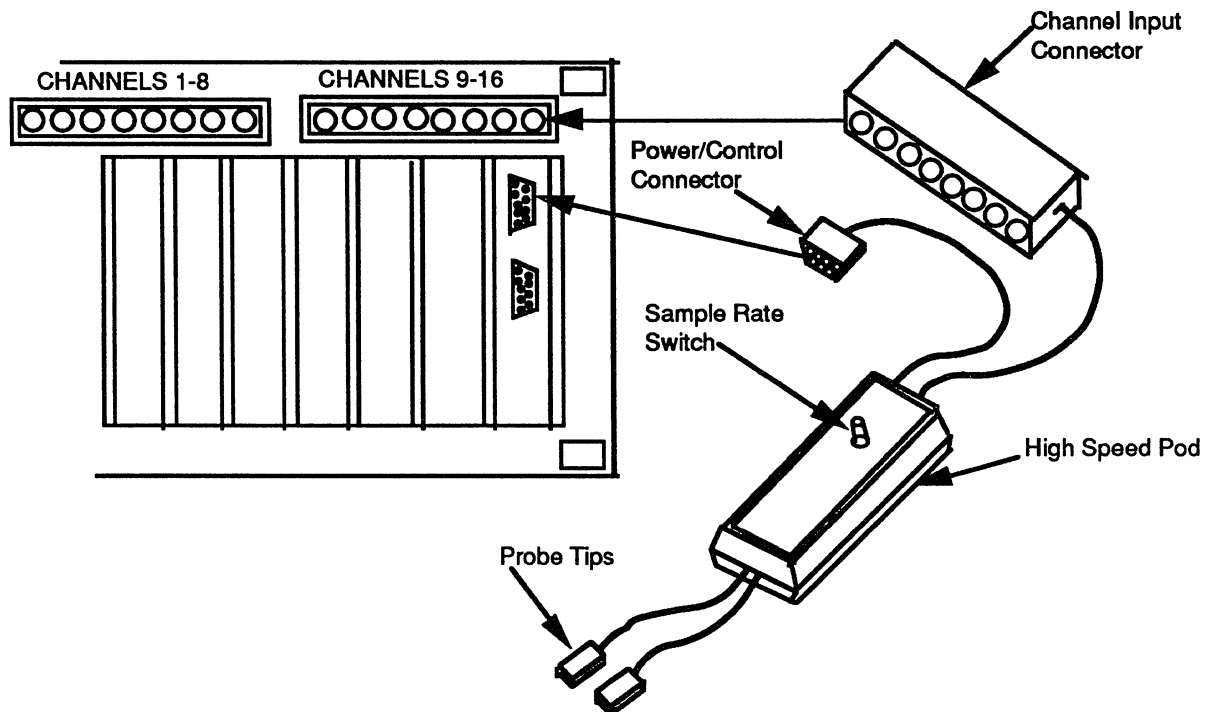

**Figure 9-1. 800 MSample Probe Connections**

The 800 MSample Probe has a two-position toggle switch to select between the following two input configurations:

- 1 channel at 800 Msamples/sec (1.25 ns resolution), by 8K deep,
- 2 channels at 400 Msamples/sec (2.50 ns resolution), by 4K deep

The 800 MSample Probe is used when high resolution is required on signals which are not repetitive. It is also useful in situations where the trigger is repetitive, but an irregular pulse needs to be captured at a high sample rate.

The 800 MSample Probe allows the user to configure the system to take full advantage of multiple channel display/triggering and high-speed sampling at either 400 or 800 Msamples/sec. The displayed traces from the 800 MSample Probe and the standard probes are fully time aligned, allowing accurate measurements between any channels.

By increasing the maximum single-shot sample rate of the K1600 to 800 Msamples/sec, it is possible to display glitches of less than 5 ns duration without requiring that the glitches be repetitive. Single-shot, edge-to-edge timing measurements can be made with a resolution of 1.25 ns.

## Applications

Typical applications for the 800 MSample Probe include the following:

- Intermittent logic problems
- Hardware crashes caused by errant software
- Narrow glitches due to race conditions
- Glitches on a parallel bus due to signal crosstalk
- Short duration bus contention problems
- Capturing the “first” event in a repetitive sequence
- Capturing the “first” clock after startup
- Capturing the “first” disk access on a read cycle

## Theory of Operation

The 800 MSample Probe works on the principle of demultiplexing one input channel into four or eight output channels (Figure 9-2), which are then recorded by the K1600. By introducing a slight delay into each of the four or eight output channels it is possible to obtain much higher resolution than would otherwise be possible in a single-shot mode. For example, in the 800 MHz mode adjacent channels are delayed by 1/sample rate ( $1/800 \text{ Msamples/sec} = 1.25 \text{ ns}$ ).

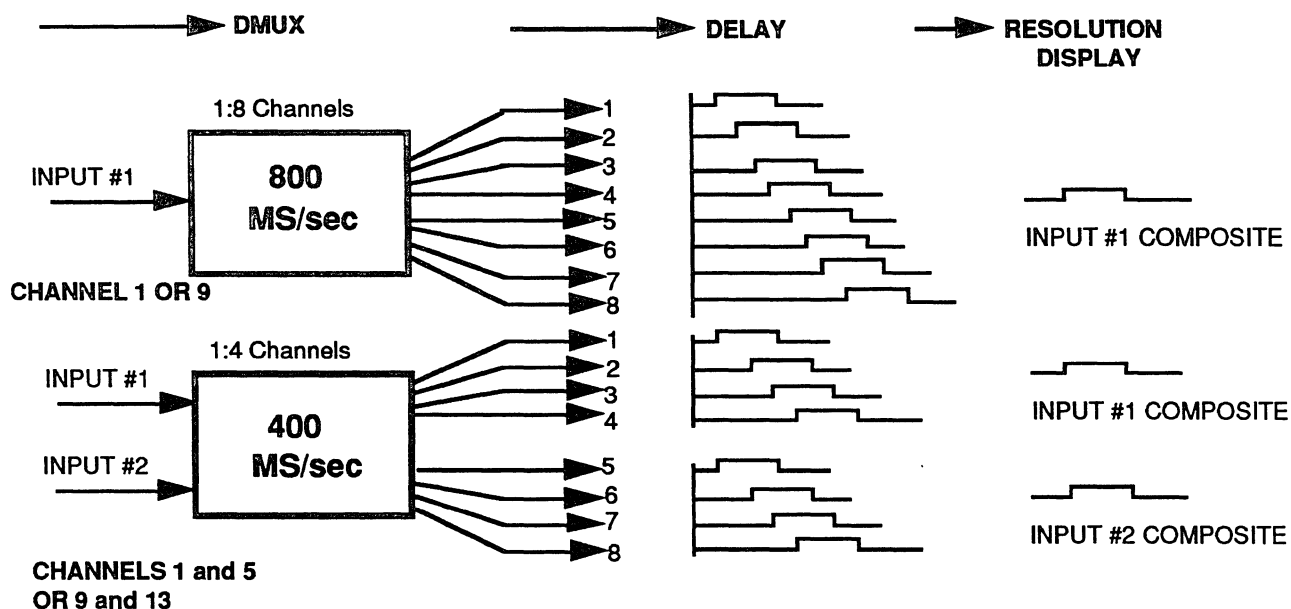
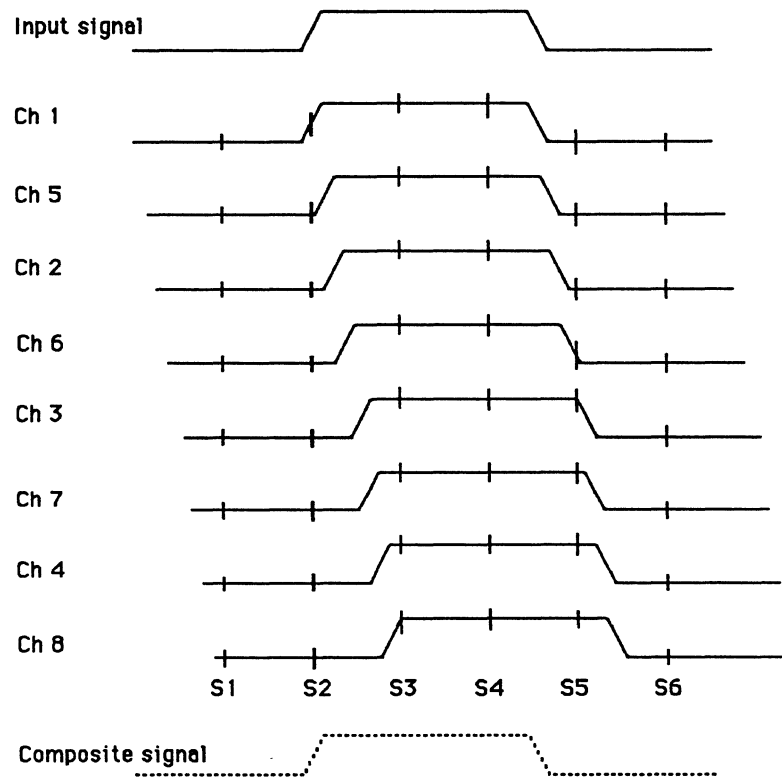

Figure 9-2. Demultiplex of Input to Obtain High-Resolution Output

The diagram of Figure 9-3 shows how the probe works in the 800 MHz mode.



**Figure 9-3. Channel Delay Propagation for 800 MHz Mode**

## Probe Setup

Begin by connecting the 800 MSample Probe to one of the Channel Input Connectors on the rear panel. Two 800 MSample Probes may be used by connecting one probe to each Channel Input group. Connect the power and control cable to the nine-pin 800 MSample Probe connector on rear panel.

The lower nine-pin connector selects and displays channel 1 for 800 Msamples/sec rate or channels 1 and 5 for 400 Msamples/sec rate.

The upper nine-pin connector selects and displays channel 9 for 800 Msamples/sec rate or channels 9 and 13 for 400 Msamples/sec rate.

Connect one or both input probe tips to the target circuit or device under test. At 400 Msamples/sec, both probe tips may be used to provide signals on channels 1 and 5. At 800 Msamples/sec only one probe tip is used, to provide a signal on channel 1 or 9. Move the selector switch to the desired sampling speed, 400 or 800 Msamples/sec. An incorrect switch setting cannot damage the probe but will cause an incorrect wave-form display.

The greatest signal fidelity will be obtained by connecting the probe directly to two 0.025" pins on 0.100" centers mounted on the circuit under test. Optional adapter wires and grabbers may be used with slower-speed signals but some signal fidelity will be lost when measuring fast signals.

### Menu Setup

Use the **More** key to select choice number 2, Probe Selection. This will cause a small pop-up menu to appear which displays a Probe Type selection field for each active input group. Use the cursor control keys and the **Next** or **Previous** key to roll the desired input group or groups to 400 MHz or 800 MHz. Note that the active channels for this selection are displayed just to the left of the selection field.

An example of the Probe Selection Menu is shown in Figure 9-4.

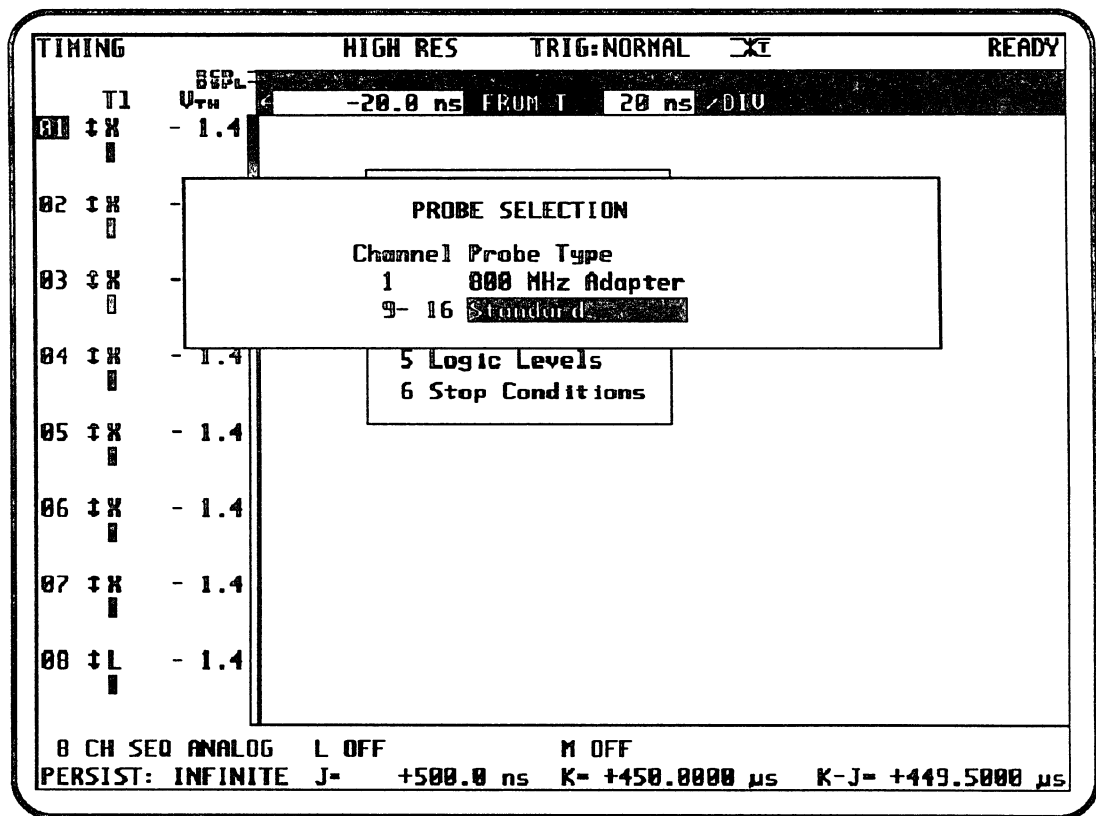

Figure 9-4. Probe Selection Pop Up Menu

Press the **Timing** key to display the Timing Screen. Move the blinking cursor to the Trigger Mode field and change the mode to **SINGLE**, putting the unit in single-shot, low-resolution mode.

The values for Volts Full-Scale, Volts Threshold, and Volts Offset are set as they would normally be set when using standard probes. If one or both of the high-speed

channels are to be used as the trigger channel(s), the trigger bit should be set on channel 1 and/or channel 5 in the same manner as it would be set for a standard probe.

Press the **Setup** key to display the Setup Menu. Note that some channels are blanked from the display when the 800 MSample Probe was selected. If the 800 MHz mode is selected, seven channels will be blanked for each probe, while selecting the 400 MHz mode causes only six channels to be blanked. Set a trigger bit on one of the high-speed channels.

Initially, the display may be set for 4-channel, 8-channel, or 16-channel sequential display. This will leave several channel positions on the display unused (blank) but these may be changed later.

The initial display for a 400 Msamples/sec application might look like the example of Figure 9-5.

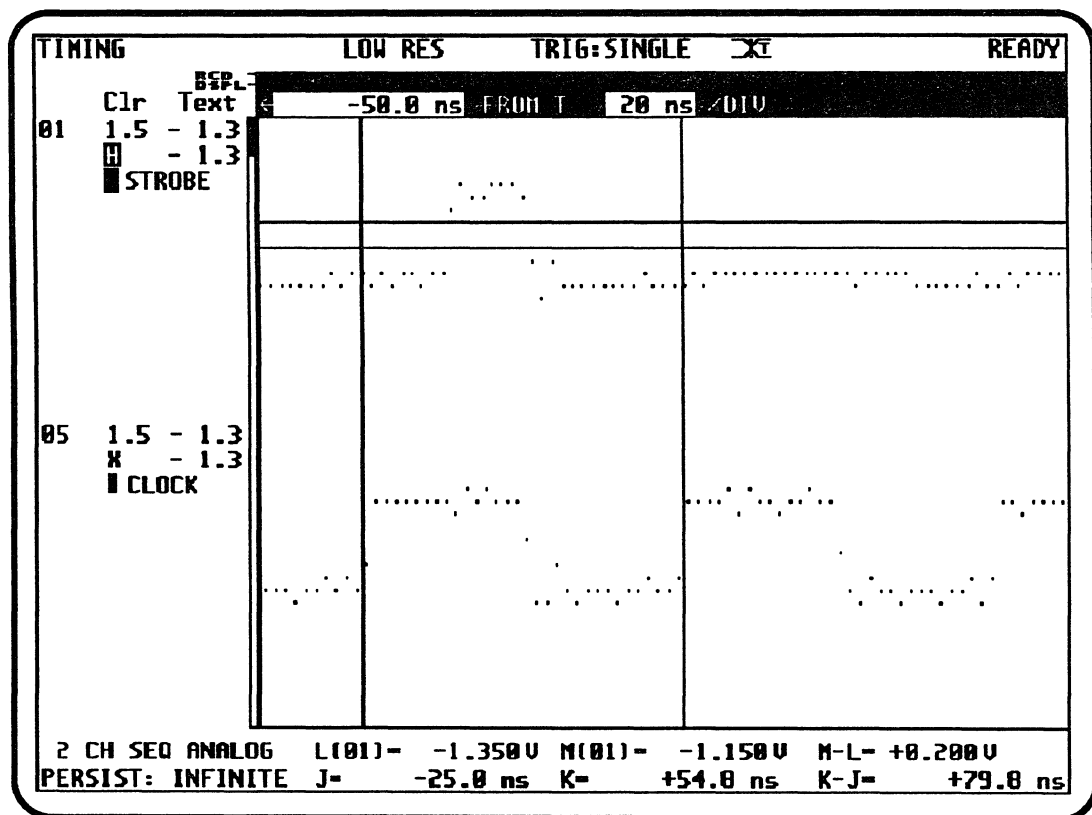

Figure 9-5. Typical Display for 400 Msamples/sec Application

## Optimizing the Display

The display described above is not the ideal display for signals from the 800 MSample Probe, because it leaves large parts of the viewing area unused. The steps below describe another way to use the view area.

- Think of the waveform display area as containing 16, 8, 4, or 2 individual viewing areas, depending on the mode selected (sequential viewing mode only). These viewing areas are part of a larger display area containing 32 individual “slots” which may be used by the operator for viewing combinations of signals.
- Waveform display information is stored in a database format. This allows the waveform from any channel to be displayed in any of the 32 individual “slots” and moved into position by using the **Scroll Up**, **Scroll Dn**, **Page Up**, and **Page Dn** keys. The **Scroll Up** and **Scroll Dn** keys move the viewing area one “slot” at a time, while the **Page Up** and **Page Dn** keys move the viewing area one “page” at a time (16, 8, 4, or 2 channels).
- The vertical bar just to the left of the waveform viewing area shows the location of the viewing area relative to the 32-channel capacity of the display area.
- To prepare the viewing area as desired, simply move the blinking cursor to the channel number field for any displayed channel and enter the desired channel number from the keypad or external ASCII keyboard.

The diagram of Figure 9-6 shows the operation of the Display Area Indicator.

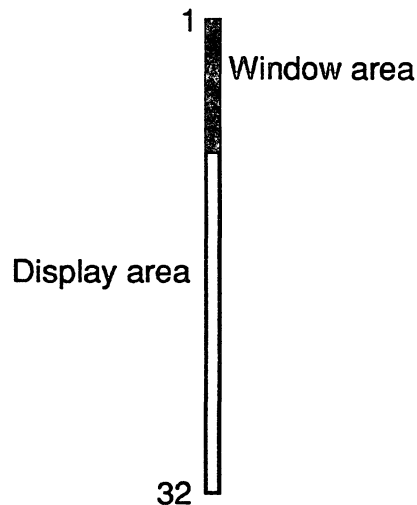

Figure 9-6. Display Area Indicator

An example which combines one high-speed channel with three normal channels is shown in Figure 9-7.

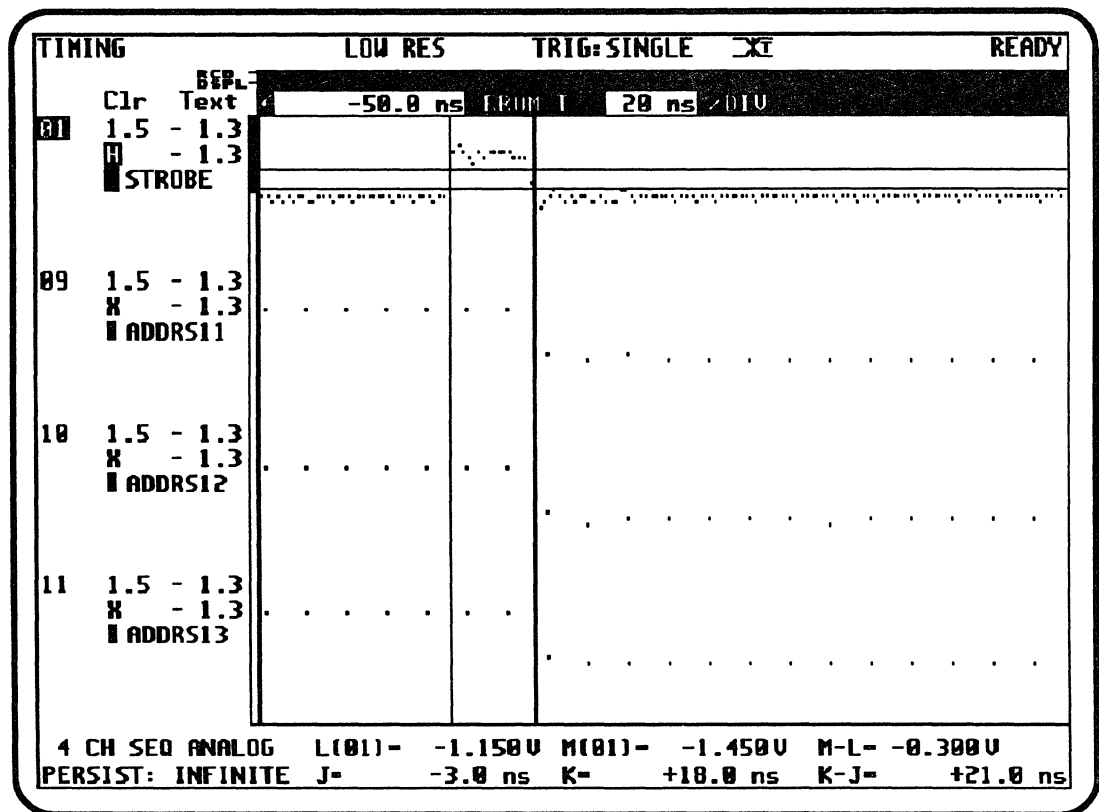

Figure 9-7. High Speed Channel Combined with Three Normal Channels

Once the display is configured as desired, it may be saved to disk as a setup or setup and data file and recalled when needed. In addition, the last setup used before the instrument is turned off will be restored by the Autosave feature when the unit is powered up.

One word of caution: If the probe selection field is returned to Standard, the display will remain as configured and may not show the desired channels. Simply repeat the above steps to restore the screen to its normal configuration. Once restored, this setup may be saved to disk for future use.

## 800 MSample Probe Specifications

Input Channels	1 Channel at 800 Msamples/sec, (1.25 ns), by 8K deep, or 2 Channels at 400 Msamples/sec, (2.50 ns), by 4K deep
Volts Offset Range	-40.0 V to +40.0 V, for each channel
Analog Bandwidth	250 MHz
Input Capacitance	6 pF
Input Resistance	26 k $\Omega$

Trigger Window	The trigger window increases if you use a mixture of 800 MSample Probe inputs and standard probe inputs together in the trigger word.								
	<table> <thead> <tr> <th><i>Trigger Specification</i></th> <th><i>Minimum Trigger Window</i></th> </tr> </thead> <tbody> <tr> <td>Standard channels only</td> <td>2 ns</td> </tr> <tr> <td>800 MSample channels only</td> <td>2 ns</td> </tr> <tr> <td>Mixture of Std &amp; 800 MS</td> <td>5 ns</td> </tr> </tbody> </table>	<i>Trigger Specification</i>	<i>Minimum Trigger Window</i>	Standard channels only	2 ns	800 MSample channels only	2 ns	Mixture of Std & 800 MS	5 ns
<i>Trigger Specification</i>	<i>Minimum Trigger Window</i>								
Standard channels only	2 ns								
800 MSample channels only	2 ns								
Mixture of Std & 800 MS	5 ns								
Power Requirements	+12 to -12 VDC supplied from K1600 rear panel								
Physical Size	Probe Pod 6" L (15.2 cm), by 3" W (7.6 cm), by 3" H (7.6 cm) with attached cables as follows: <ul style="list-style-type: none"> <li>Two Probe Tip cables, 6' L (182.9 cm)</li> <li>One Channel Input cable, 6' L (182.9 cm) with 8-pin connector</li> <li>Control cable, 6' L (182.9 cm) with 9-pin, D-type connector</li> </ul>								
Weight	3 lb (1.35 kg)								
Operating Modes	All scope modes, single-shot and repetitive (Data subject to change without notice)								

## INTERNAL HARD DISK

The optional internal hard disk provides 40 Mbytes of storage and increased speed when saving and recalling files for menu setups and recorded data. The optional hard disk usually is factory-installed and configured. You may order it when you purchase the K1600. You may also order it at a later date and installed by the customer.

If you Analyzer has the optional hard disk drive, from the Disk Screen, use key **8** to toggle between the installed disk drives as shown below:

- Drive A (the floppy disk drive)
- Drive C (the optional internal hard disk drive)

The lower part of the screen displays the active drive as follows:

```
Directory:  A:\
```

Chapter 6 describes full instructions on disk operation.

## EXTERNAL KEYBOARD

The optional external ASCII Keyboard plugs into the K1600 rear panel and provides full alphanumeric capability for ease of entry for waveform labels and disk filenames. In addition, the external keyboard allows remote operation with an external VGA color



monitor. You may order this keyboard from your Biomatic distributor or sales representative.

You may use any AT-compatible ASCII keyboard with the Logic Waveform Analyzer provided it has a standard round five-pin DIN connector. You may also use switchable or self-configurable XT/AT keyboards as long as they come with the correct connector. Figure 9-8 shows connector details.

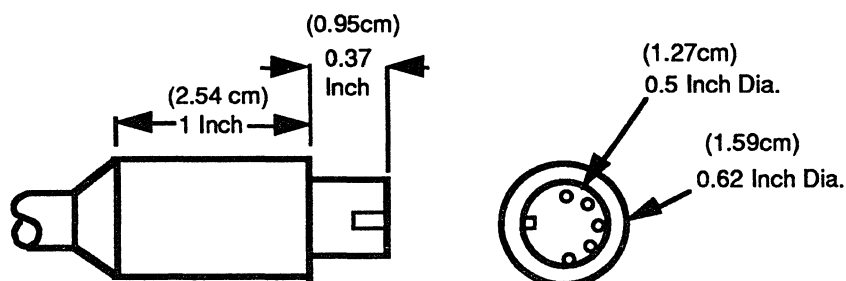

Figure 9-8. Keyboard Connector Details

Using the external keyboard does not disable the built-in keypad. Both the keypad and keyboard are active at all times, and you may use them interchangeably. This is a special convenience for those who prefer using the built-in keypad for some functions and the remote keyboard for others.

Since the arrangement of keys on the keyboard is different from the keypad, the external keyboard uses a different keying sequence for a corresponding keypad entry. Table 7-1 presents the equivalent keyboard entry versus the keypad entry.

## GPIB CONTROL

The optional GPIB Control provides an IEEE-488 communications interface between a GPIB host controller and the K1600 instrument.

The optional hardware consists of a GPIB PC board, which the factory installs in the K1600 chassis, to provide a parallel port for the communications link. The factory installs and configures the GPIB hardware. You may order it when you purchase the K1600. You may also order it at a later date and install it yourself.

The K1600 operates as a peripheral device to receive commands and data messages sent from the GPIB host controller and responds to information requests from the host. The unit transfers data in ASCII code except for binary transfer of Acquisition Data queries.

The GPIB option includes a feature for Remote and Local Mode operation. In Remote Mode, the K1600 is fully-dedicated to the GPIB host controller via local lockout conditions. The unit ignores any K1600 keypad or external keyboard entry.

In Local Mode with the Local Lockout condition overridden, the K1600 responds to keypad and external keyboard entry to perform normal analyzer operations.

Chapter 10 describes full details of the GPIB Option.



## **Chapter 10**

# **GPIB OPTION**

---

## **OVERVIEW**

### **Introduction**

This Chapter describes the GPIB Option (Product Number A16004) which is an accessory for the K1600 Logic Waveform Analyzer. This option provides an IEEE-488 Communications Interface between the user's host controller and the K1600 instrument at the user's workstation environment.

## **GPIB OPERATION**

The K1600 Logic Waveform Analyzer operates as a peripheral with the GPIB host controller. The K1600 is enabled for remote GPIB operation whenever it is connected to the host and selected for data transfers. The commands and data issued at the host initiate K1600 Analyzer functions and send data to, and receive data from the K1600 RAM memory. The host can initiate a recording, send and receive setup information, and interrogate K1600 status.

The K1600 receives commands and data sent from the host and responds by sending requested data to the host. The data is sent and received entirely in ASCII Code, except for response to binary transfer of Acquisition Data queries.

## **GPIB CABLE CONNECTIONS**

The GPIB components are factory-installed in the basic K1600 unit as a user specified option. These components provide the parallel I/O port which interfaces to the users GPIB host controller network.

The GPIB connector is located on the K1600 rear panel described in Chapter 7. Turn off AC power at the host controller and K1600 unit. Connect the GPIB cable from host controller to the GPIB connector.

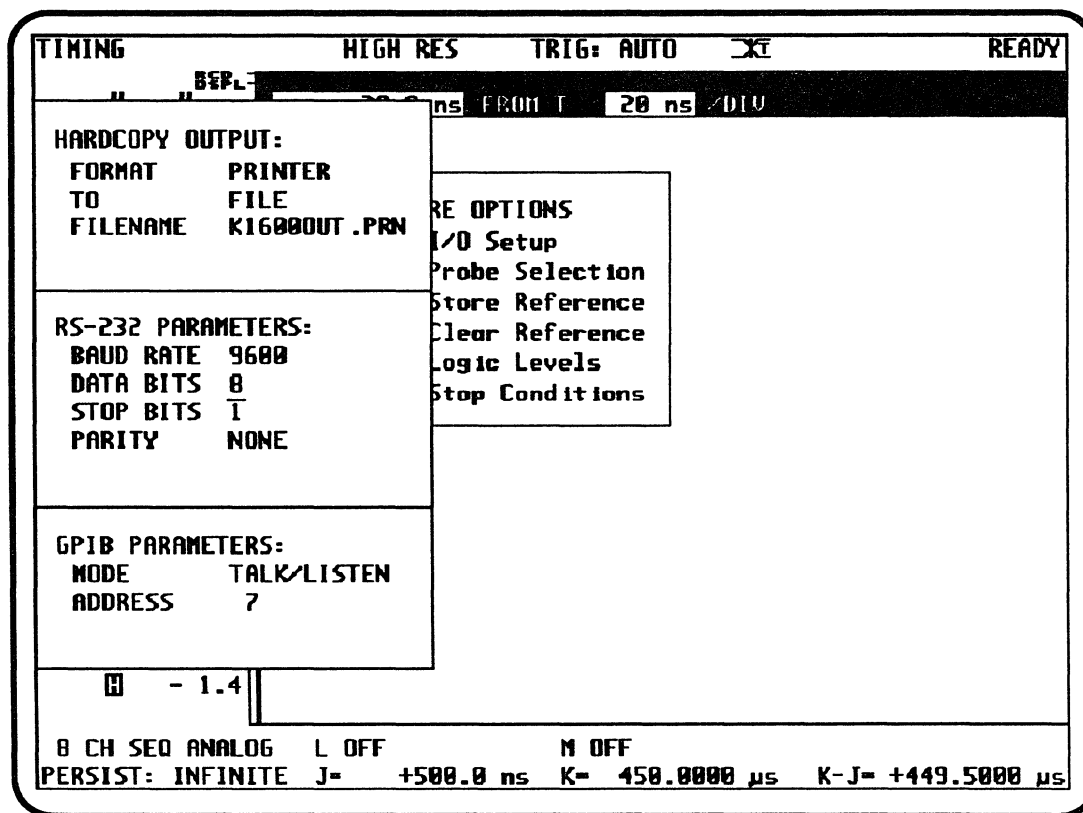

Figure 10-1. I/O Setup Screen

## GPIB STARTUP

Turn on AC power at the GPIB host controller and K1600 Logic Waveform Analyzer. The K1600 will perform its internal diagnostic check and display the Timing Screen when power is completed.

Press the **More** key on front panel keypad to display the More Options Menu. Then, press the 1 key to select the I/O Setup Menu (Figure 10-1).

The following GPIB parameters are indicated on the I/O Setup Screen:

```

GPIB PARAMETERS
MODE           TALK/LISTEN
ADDRESS       7
    
```

All GPIB parameters for the K1600 are fixed except for the I/O Device Address assignment number located on the bottom of the menu. As shown on the menu, the K1600 operates in GPIB Talk/Listen Mode. A unique address between 0 and 30 must be selected by the user as determined by the GPIB host controller requirement. The default address of 7 is assigned by the K1600.

## REMOTE/LOCAL OPERATION

The GPIB Option contains a feature that allows you to operate the K1600 as a stand-alone instrument while it is connected to the GPIB controller. The conditions associated with Remote and Local Mode operation are described below:

### Remote Mode

At any time while the K1600 is connected to the host controller, the host can force the K1600 into Remote Mode by activating the Remote/Enable (REN) line in the communications network and addressing the K1600 to Listen.

In the Remote Mode, all K1600 functions are totally-controlled by the host. Key entries made at the front panel keypad or external keyboard are ignored.

While the Remote Mode is active, and the Local Lockout condition is also active, pressing any key on the K1600 causes a message, GPIB LOCKOUT, to appear in the upper-left-hand corner of the screen. This message indicates the Remote Mode is active, and the K1600 is busy communicating with the host controller.

### Local Mode

Local Mode operation allows the user to operate the K1600 in Stand-Alone Mode under certain conditions as follows:

When Remote Mode is active, but the Local Lockout condition is not active, pressing any key on the K1600 causes a message, STOP FOR RTL (Remote to Local Transition), to appear in the upper left-hand corner of the screen. The user can press the **Stop** key to restore Local Mode operation.

This action causes the RTL bit to be set in the GPIB Status Register (see description of Device Status Reporting near the end of this chapter). The K1600 can now respond to entries made at the keypad or external keyboard to execute stand-alone analyzer functions.

## COMMUNICATION PROTOCOL

The I/O communications and data transfer dialog occur in the form of messages between the GPIB host controller and the K1600 device.

Messages are generally categorized as “program messages” (messages sent from the controller to the K1600) and “response messages” (messages sent from the K1600 to the controller) as shown in Figure 10-2.

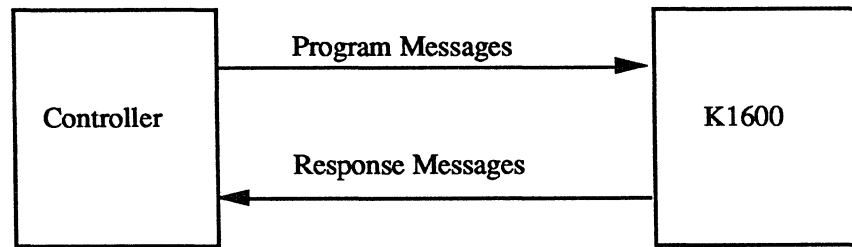

Figure 10-2. GPIB Communications Protocol

## Message Syntax

Program messages may be *Commands* or *Queries*. Commands instruct the K1600 to initiate an action or to select a particular device configuration. The message elements presented in *italics* indicate this information must be specified by the user for the Command or Query entry.

The syntax for each type of message is formatted as follows:

**Command** *<program header><pmt>*  
 or  
*<program header><program header separator><program data><pmt>*

Queries request a response from the K1600 and are formatted as follows:

**Query** *<program header>?<pmt>*

The *<program header>* element uniquely specifies the message. If *<program data>* is included in a message, it is separated from the *<program header>* by a *<program header separator>* character (ASCII space, 20 hex). The *<pmt>*, or program message terminator, is an ASCII newline character (0A hex).

## Special Characters Used in Syntax

Special characters used in the syntax are listed below.

*Character Description*

- ; Semicolon is used as separator for multiple message unit entries.
- ,
- Comma is used to separate a sequence of program data.
- :
- Colon placed in front of header identifies this entry as a Specific Device header. The colon is also used as a separator for compound elements.
- ( )
- Parenthesis is used to enclose a value that is duplicated for a range.
- \*
- Asterisk placed in front of a command denotes this entry is an IEEE-488.2 Common Command.
- ?
- Question mark following a command header indicates this message is a Query.

- Underline is used as a separator between the low and high values for a range.
- " " Double quotation marks enclose a text field.

## Combining Multiple Message Units

Multiple program message units may be included in a single message by using a semi-colon (;) character to separate the units. For example, the following three message units:

```
:acq:mode s<pmt>
:vth:ch1 1.4<pmt>
:go<pmt>
```

may be combined in a single message unit as follows:

```
:acq:mode s;:vth:ch1 1.4;:go<pmt>
```

Multiple program unit messages may include only one query which must be the last unit before the program message terminator. Since each unit is processed as it is received, the system bus would be deadlocked if more than one query was included in a message. Similarly, once a query which requires a response is received, the device waits to be addressed to talk in order to output the response, and if it is instead addressed to listen, a Query Error will result.

## Compound Message Headers

Some messages use simple headers but most K1600 device messages use compound headers to provide for grouping of related variables for display setup, hardware setup, and recorded data. All device specific headers begin with an ASCII colon (:) character and program mnemonics within a compound program header are separated using the colon character.

```
:STOP           (Simple header)
:TRG:VTH?      (Compound header)
:TLE:CH1_8     (Compound header)
```

A multiple compound program message unit may be simplified if each element contains the same root command header. For example, the following compound message unit consisting of:

```
:acq:mode s;:acq:pers I;:acq:vres h<pmt>
```

is equivalent to the simplified version of:

```
:acq:mode s;pers I;vres h<pmt>
```



## Assign Value for Range of Elements

Program messages sent to the device to duplicate a value for a range of channels, probe groups, or timing display sequence parameters may be simplified by using parentheses to enclose the value to be duplicated. For example, the threshold voltage for channels one through nine may be set to 1.4 V by sending the device

```
:vth:ch1_9 (1.4) <pmt>
      OR
:vth:ch1_9 1.4,1.4,1.4,1.4,1.4,1.4,1.4,1.4,1.4 <pmt>
```

## USER REFERENCE DATA

The description of Device Status Reporting and Synchronization Techniques for controlling GPIB communications is provided at the end of this chapter.

A cross-reference index is also provided at the end of this chapter to identify the page location for each command used for GPIB communications.

## COMMON COMMANDS

### General

GPIB common commands are program messages which are defined by the IEEE-488.2 Standard. These commands begin with an asterisk (\*) character and there may be no space separating the asterisk and header.

```
*<common command header><pmt>
```

### Command Names

The following IEEE STD 488.2 common commands are supported by the GPIB Option:

<i>Command Header</i>	<i>Description</i>
*CLS	Clear Status Command
*ESE	Standard Event Status Enable Command
*ESE?	Standard Event Status Enable Query
*ESR?	Standard Event Status Register Query
*IDN?	Identification Query
*OPC	Operation Complete Command
*OPC?	Operation Complete Query
*RST	Reset Command
*SRE	Service Request Enable Command

*SRE?	Service Request Enable Query
*STB?	Read Status Byte Query
*TST?	Self-Test Query
*WAI	Wait-to-Continue Command

## COMMON COMMANDS FORMAT

### \*CLS Clear Status Command

**Function** The Clear Status command clears the Standard Event Status Register and the Status Byte, and forces the device to the Operation Complete Command Idle State and the Operation Complete Query Idle State.

**Syntax** \*CLS<pmt>

### \*ESE Standard Event Status Enable Command

**Function** The Standard Event Status Enable command sets the Standard Event Status Enable register bits.

**Syntax** \*ESE<program header separator><integer value 0-255><pmt>

**Example** \*ESE 255<pmt>

### \*ESE? Standard Event Status Enable Query

**Function** The Standard Event Status Enable Query requests a response of the current contents of the Standard Event Status Enable register.

**Query Syntax** \*ESE?<pmt>

**Response Syntax** <integer value 0-255><pmt>

### \*ESR Standard Event Status Register Query

**Function** The Standard Event Status Register query requests a response of the current contents of the Standard Event Status Register.

**Query Syntax** \*ESR?<pmt>

**Response Syntax** <integer value 0-255><pmt>

### \*IDN? Identification Query

**Function** The Identification query requests a device identification response.

**Query Syntax** \*IDN?<pmt>

**Response Syntax** BIOMATION, K1600, <serial #>, <firmware rev#><pmt>

**\*OPC                    Operation Complete Command**

**Function**                    The Operation Complete command causes the device to generate the operation complete message in the Standard Event Status Register when all pending selected device operations have been finished.

**Syntax**                      *\*OPC<pmt>*

**\*OPC                    Operation Complete Query**

**Function**                    The Operation Complete query causes the device to output an ASCII character 1 when all pending selected device operations have been finished.

**Query Syntax**              *\*OPC?<pmt>*

**Response Syntax**        *1<pmt>*

**\*RST                    Reset Command**

**Function**                    The Reset command forces the device to the Operation Complete Idle State and the Operation Query Idle State.

**Syntax**                      *\*RST<pmt>*

**\*SRE                    Service Request Enable Command**

**Function**                    The Service Request Enable command sets the Service Request Enable Register bits.

**Syntax**                      *\*SRE<program header separator><integer value 0-255><pmt>*

**Example**                      *\*SRE 128<pmt>*

**\*SRE?                   Service Request Enable Query**

**Function**                    The Service Request Enable query requests the current contents of the Service Request Enable register.

**Query Syntax**              *\*SRE?<pmt>*

**Response Syntax**        *<integer value 0-255><pmt>*

**\*STB?                   Read Status Byte Query**

**Function**                    The Read Status Byte query requests the contents of the status byte and Master Summary Status bit.

**Query Syntax**              *\*STB?<pmt>*

**Response Syntax**        *<integer value 0-255><pmt>*

**\*TST? Self-Test Query**

<b>Function</b>	Device returns 0.
<b>Query Syntax</b>	<b>*TST?</b> < <i>pmt</i> >
<b>Response Syntax</b>	0< <i>pmt</i> >

**\*WAI Wait-to-Continue Command**

<b>Function</b>	The Wait-to-Continue command shall prevent the device from executing any further commands until no operations are pending.
<b>Syntax</b>	<b>*WAI</b> < <i>pmt</i> >

**DEVICE-SPECIFIC MESSAGES****General**

Device specific messages enable the user to set up and control the device, and to retrieve data and status information remotely.

**Functional Elements****<CHANNEL NUMBER>**

<b>Function</b>	The < <i>CHANNEL NUMBER</i> > element specifies a channel number between 1 and 16.
<b>Syntax</b>	The < <i>CHANNEL NUMBER</i> > is an unsigned integer.

**<CHANNEL RANGE>**

<b>Function</b>	The < <i>CHANNEL RANGE</i> > element specifies a sequential range of one or more channels from 1 through 16.
<b>Syntax</b>	<i>CH</i> < <i>channel number</i> > or <i>CH</i> < <i>channel number</i> >_< <i>channel number</i> >
<b>Example</b>	<i>CH1</i> ( <i>channel 1</i> ) <i>CH2_10</i> ( <i>channels 2 through 10</i> )

**<GROUP NUMBER>**

<b>Function</b>	The < <i>GROUP NUMBER</i> > element specifies a probe group number between 1 and 2 such that 1 represents channels 1-8, and 2 represents 9-16.
-----------------	--

<b>Syntax</b>	The <i>&lt;GROUP NUMBER&gt;</i> is an unsigned integer.
<b>&lt;GROUP RANGE&gt;</b>	
<b>Function</b>	The <i>&lt;GROUP RANGE&gt;</i> element specifies a sequential range of one or more probe groups from 1 through 2.
<b>Syntax</b>	<i>GP&lt;group number&gt;</i> or <i>GP&lt;group number&gt;_&lt;group number&gt;</i>
<b>Example</b>	<i>GP 1</i> (group 1; channels 1 through 8) <i>GP 1_2</i> (groups 1&2; channels 1-8, 9-16)
<b>&lt;PMT&gt;</b>	
<b>Function</b>	The <i>&lt;PMT&gt;</i> is the program message terminator.
<b>Syntax</b>	The newline character (0A hex) in conjunction with the EOI line is the <i>&lt;PMT&gt;</i> .
<b>&lt;SAMPLE NUMBER&gt;</b>	
<b>Function</b>	The <i>&lt;SAMPLE NUMBER&gt;</i> element specifies an “absolute” sample number for acquired data. This value ranges from 0 through 999.
<b>Syntax</b>	The <i>&lt;SAMPLE NUMBER&gt;</i> is an unsigned integer value.
<b>&lt;SAMPLE RANGE&gt;</b>	
<b>Function</b>	The <i>&lt;SAMPLE RANGE&gt;</i> element specifies a sequential range of one or more samples.
<b>Syntax</b>	<i>SN&lt;sample number&gt;</i> or <i>SN&lt;sample number&gt;_&lt;sample number&gt;</i>
<b>Example</b>	<i>SN 1</i> <i>SN 1_30</i>
<b>&lt;SEQN NUMBER&gt;</b>	
<b>Function</b>	The <i>&lt;SEQN NUMBER&gt;</i> element specifies a display sequence index number between 0 and 31.
<b>Syntax</b>	The <i>&lt;SEQN NUMBER&gt;</i> is an unsigned integer value.
<b>&lt;SEQN RANGE&gt;</b>	
<b>Function</b>	The <i>&lt;SEQN RANGE&gt;</i> element specifies a sequential range of one or more display sequence indices.

<b>Syntax</b>	<code>IS&lt;seqn number&gt;</code> or <code>IS&lt;seqn number&gt;_&lt;seqn number&gt;</code>
<b>Example</b>	<code>IS0</code> (first element in display sequence) <code>IS1_7</code> (second through eighth element in display)

**<TIME VALUE>**

<b>Function</b>	The <i>&lt;TIME VALUE&gt;</i> element specifies a time value in seconds.
<b>Syntax</b>	<i>&lt;signed integer or decimal number&gt;&lt;suffix mult&gt;s</i> where <i>&lt;suffix mult&gt;</i> is <b>M</b> (milli), <b>U</b> (micro), <b>N</b> (nano), <b>P</b> (pico).
<b>Example</b>	<code>1 NS</code> (one nanosecond) <code>250.0 US</code> (two hundred-fifty microseconds) <code>-4.10 MS</code> (-4.1 milliseconds)

**DISPLAY SETUP MESSAGES****General**

Display Setup messages consist of Commands, Queries, and Responses. Display setup Commands are sent to the device to select the display configuration for K1600 recorded data. Display setup Queries are sent to the device to request display setup Response Messages which inform the controller of the settings of the requested parameters.

<i>Message Name</i>	<i>Description</i>
<code>:COL:&lt;channel range&gt;</code>	Channel trace display color
<code>:CURS:JTIM</code>	J-cursor value
<code>:CURS:KTIM</code>	K-cursor value
<code>:CURS:LCV</code>	L-amplitude cursor value
<code>:CURS:LE</code>	L-amplitude cursor-channel select
<code>:CURS:MCV</code>	M-amplitude cursor value
<code>:CURS:ME</code>	M-amplitude cursor-channel select
<code>:DISP:MODE</code>	Display Mode—Analog or Digital
<code>:DISP:ONS</code>	Number of traces on screen
<code>:DISP:ORG</code>	Display organization Seq/Overlay
<code>:DISP:PAR</code>	Timing display parameter choice
<code>:DISP:SCR</code>	Display screen select
<code>:DISP:SEQ:&lt;seqn range&gt;</code>	Timing display channel display sequence
<code>:DISP:TOP</code>	Index of top trace in sequence on timing screen
<code>:DISP:VIH:&lt;channel range&gt;</code>	High-logic level—Time chart display mode
<code>:DISP:VIL:&lt;channel range&gt;</code>	Low-logic level—Time chart display mode
<code>:GLOB:COL</code>	Global parameters—trace color select

: GLOB: END	Global parameters—end channel select
: GLOB: PAR	Global parameters—parameter select
: GLOB: STA	Global parameters—starting channel
: GLOB: TEXT	Global parameters—trace text label
: GLOB: TLE	Global parameters—channel trigger level
: GLOB: VFS	Global parameters—channel full-scale voltage
: GLOB: VG	Global parameters—Vglobal select
: GLOB: VOS	Global parameters—channel offset voltage
: GLOB: VTH	Global parameters—channel threshold voltage
: TEXT: <channel range>	Channel text label
: VG1: TEXT	Vglobal1 text name identifier
: VG1: VFS	Vglobal1 channel full-scale voltage
: VG1: VOS	Vglobal1 channel offset voltage
: VG1: VTH	Vglobal1 channel threshold voltage
: VG2: TEXT	Vglobal2 text name identifier
: VG2: VFS	Vglobal2 channel full-scale voltage
: VG2: VOS	Vglobal2 channel offset voltage
: VG2: VTH	Vglobal2 channel threshold voltage
: VG3: TEXT	Vglobal3 text name identifier
: VG3: VFS	Vglobal3 channel full-scale voltage
: VG3: VOS	Vglobal3 channel offset voltage
: VG3: VTH	Vglobal3 channel threshold voltage
: GEXE	Execute Global Changes

## DISPLAY SETUP COMMANDS FORMAT

### : COL Channel Trace Display Color

**Function** Selects the channel trace color for one or more channels for the Timing display.

**Query Syntax** :COL:<channel range>?<pmt>

**Cmd/Rsp Syntax** :COL:<channel range> <color><pmt>

where <color> is 0 through 7 representing color (or monochrome) value as follows:

0 Orange (medium)	4 Blue (medium)
1 Red (light)	5 Magenta (light)
2 Cyan (bright)	6 Yellow (bright)
3 Green (bright)	7 White (bright)

**Example** :COL:CH1\_3?  
:COL:CH1\_3 3,2,1

**:CURS:JTIM J-Cursor Position**

**Function** Selects the J timing cursor position.

**Query Syntax** :CURS:JTIM?<pmt>

**Cmd/Rsp Syntax** :CURS:JTIM <time value> <pmt>

where <time value> is -500 ms to 32 s dependent on time per division selected

**Example** :CURS:JTIM -105. us

**:CURS:KTIM K-Cursor Position**

**Function** Selects the K timing cursor position.

**Query Syntax** :CURS:KTIM?<pmt>

**Cmd/Rsp Syntax** :CURS:KTIM <time value> <pmt>

where <time value> is -500 ms to 32 s dependent on time per division selected

**Example** :CURS:KTIM -105. us

**:CURS:LCV L-Amplitude Cursor Value**

**Function** Selects the L cursor voltage value.

**Query Syntax** :CURS:LCV?<pmt>

**Cmd/Rsp Syntax** :CURS:LCV <voltage><pmt>

where <voltage> is from -45 to 45; resolution is dependent on Volts Full-Scale, Volts Offset, and the number of channels selected.

**Example** :CURS:LCV 1.23

**:CURS:LE L-Amplitude Cursor-Channel Select**

**Function** Selects the channel trace number where the L-voltage cursor is displayed.

**Query Syntax** :CURS:LE?<pmt>

**Cmd/Rsp Syntax** :CURS:LE <channel number or 0><pmt>  
<channel number> if 0, L-cursor not active

**Example** :CURS:LE 5

**:CURS:MCV M-Amplitude Cursor Value**

**Function** Selects the M-cursor voltage value.

**Query Syntax** :CURS:MCV?<pmt>



**Cmd/Rsp Syntax** :CURS:MCV <voltage><pmt>

where <voltage> is from -45 to 45; resolution is dependent on Volts Full-Scale, Volts Offset, and the number of channels selected.

**Example** :CURS:MCV 1.0

### :CURS:ME M-Amplitude Cursor-Channel Select

**Function** Selects the channel trace number where the M-voltage cursor is displayed.

**Query Syntax** :CURS:ME?<pmt>

**Cmd/Rsp Syntax** :CURS:ME <channel number or 0><pmt>  
<channel number> if 0, M-cursor not active

**Example** :CURS:ME 0

### :DISP:MODE Display Mode

**Function** Selects the display mode for the timing display.

**Query Syntax** :DISP:MODE?<pmt>

**Cmd/Rsp Syntax** :DISP:MODE <dmode><pmt>  
where <dmode> is A (analog) or D (digital).

**Example** :DISP:MODE A

### :DISP:ONS Number of Traces On Screen

**Function** Selects the number of traces on screen on the timing display.

**Query Syntax** :DISP:ONS?<pmt>

**Cmd/Rsp Syntax** :DISP:ONS <ons><pmt>  
where <ons> is 2, 4, 8, or 16.

**Example** :DISP:ONS 4

### :DISP:ORG Display Organization

**Function** Selects the display organization of traces on the timing screen.

**Query Syntax** :DISP:ORG?<pmt>

**Cmd/Rsp Syntax** :DISP:ORG <org><pmt>  
where <org> is:

- s (Sequential)
- 1 (one overlay)
- 2 (two overlays)

3 (four overlays)

4 (eight overlays)

**Example** :DISP:ORG S

### :DISP:PAR Timing Display Parameter Choice

**Function** Selects the parameters to display for each trace on the timing display when 8 or 16 channels are displayed.

**Query Syntax** :DISP:PAR?<pmt>

**Cmd/Rsp Syntax** :DISP:PAR <parms><pmt>

where <parms> is:

- 1 channel Vfs, Vos
- 2 channel trigger level, Vth
- 3 channel color, text label
- 4 overlay mode-vertical position

**Example** :DISP:PAR 1

### :DISP:SCR Display Screen Select

**Function** Selects the screen for display.

**Query Syntax** :DISP:SCR?<pmt>

**Cmd/Rsp Syntax** :DISP:SCR <screen><pmt>

where <screen> is:

- T (Timing Screen)
- D (Disk Screen)
- I (I/O Setup)
- P (Probe Select)
- L (Logic Levels Menu)
- C (Stop Conditions Menu)
- S (Setup Screen).

**Example** :DISP:SCR T

### :DISP:SEQ Timing Display Channel Display Sequence

**Function** Selects the channel order for the display sequence on the timing display.

**Query Syntax** :DISP:SEQ:<seqn range>?<pmt>

**Cmd/Rsp Syntax** :DISP:SEQ:<seqn range> <channel number or 0 for no trace><pmt>

**Example** :DISP:SEQ:IS1\_4?  
:DISP:SEQ:IS1\_4 5,6,7,8

**:DISP:TOP Index of Top Trace in Display Sequence**

**Function** Selects the index of the display sequence trace to appear at the top of the Timing Screen (see :DISP:SEQ).

**Query Syntax** :DISP:TOP?<pmt>

**Cmd/Rsp Syntax** :DISP:TOP <seqn number><pmt>

**Example** :DISP:TOP 0

**:DISP:VIH High-Logic Level—Time Chart Digital Display Mode**

**Function** Selects the high-logic level for one or more channels; if the waveform is above this level, the trace appears as a logic high in Time Chart Digital Display mode.

**Query Syntax** :DISP:VIH:<channel range>?<pmt>

**Cmd/Rsp Syntax** :DISP:VIH:<channel range> <volts><pmt>

**Example** :DISP:VIH:CH2 1.4

**:DISP:VIL Low-Logic Level—Time Chart Digital Display mode**

**Function** Selects the low-logic level for one or more channels; if the waveform is below this level, the trace appears as a logic low in Time Chart Digital Display mode.

**Query Syntax** :DISP:VIL:<channel range>?<pmt>

**Cmd/Rsp Syntax** :DISP:VIL:<channel range> <volts><pmt>

**Example** :DISP:VIL:CH1 -1.0

**:GLOB:COL Global Parameters—Trace Color**

**Function** Selects the global trace color for the global parameters function on the Setup Screen.

**Query Syntax** :GLOB:COL?<pmt>

**Cmd/Rsp Syntax** :GLOB:COL <color><pmt>

where <color> is 0 through 7 representing color (or monochrome) value as follows:

- |                  |                  |
|------------------|------------------|
| 0 Orange(medium) | 4 Blue(medium)   |
| 1 Red(light)     | 5 Magenta(light) |
| 2 Cyan(bright)   | 6 Yellow(bright) |
| 3 Green(bright)  | 7 White(bright)  |

**Example** :GLOB:COL 0

**:GLOB:END Global Parameters—Ending Channel**

**Function** Selects the ending channel number for the global parameters function on the Setup Screen.

**Query Syntax** :GLOB:END?<*pmt*>

**Cmd/Rsp Syntax** :GLOB:END <*channel number*><*pmt*>

**Example** :GLOB:END 16

**:GLOB:PAR Global Parameters—Parameter Select**

**Function** Selects the channel parameter for the global parameters function on the Setup Screen.

**Query Syntax** :GLOB:PAR?<*pmt*>

**Cmd/Rsp Syntax** :GLOB:PAR <*param*><*pmt*>

where <*param*> is:

TL	for Trigger logic level
FS	for Volts Full-Scale
OF	for Volts Offset
TH	for Volts Threshold
CO	for Trace Color
LA	for Channel Text Label
VG	for Vglobal

**Example** :GLOB:PAR TL

**:GLOB:STA Global Parameters—Starting Channel**

**Function** Selects the starting channel number for the global parameters function on the Setup Screen.

**Query Syntax** :GLOB:STA?<*pmt*>

**Cmd/Rsp Syntax** :GLOB:STA <*channel number*><*pmt*>

**Example** :GLOB:STA 2

**:GLOB:TEXT Global Parameters—Trace Text Label**

**Function** Selects the global channel text label for the global parameters function on the Setup Screen.

**Query Syntax** :GLOB:TEXT?<*pmt*>

**Cmd/Rsp Syntax** :GLOB:TEXT <*text*><*pmt*>

where <*text*> is up to eight text characters enclosed within double quotes.

**Example** :GLOB:TEXT "CHANNEL"

**: GLOB: TLE      Global Parameters—Channel Trigger Level**

**Function**                Selects the global trigger level for the global parameters function on the Setup Screen.

**Query Syntax**        : GLOB: TLE? <pmt>

**Cmd/Rsp Syntax**     : GLOB: TLE <trigger><pmt>

where <trigger> is: L (low), H (high), X (don't care)

**Example**                : GLOB: TLE X

**: GLOB: VFS      Global Parameters—Full-Scale Voltage**

**Function**                Selects the global Volts Full-Scale for the global parameters function on the Setup Screen.

**Query Syntax**        : GLOB: VFS? <pmt>

**Cmd/Rsp Syntax**     : GLOB: VFS <volts><pmt>

where <volts> is between 1.0 and 10.

**Example**                : GLOB: VFS 1.0

**: GLOB: VG        Global Parameters—Vglobal Select**

**Function**                Selects the global Vglobal for the global parameters function on the Setup Screen.

**Query Syntax**        : GLOB: VG? <pmt>

**Cmd/Rsp Syntax**     : GLOB: VG <x><pmt>

where <x> is: 1, 2, or 3 (for VGx).

**Example**                : GLOB: VG 1

**: GLOB: VOS      Global Parameters—Offset Voltage**

**Function**                Selects the global Volts Offset for the global parameters function on the Setup Screen.

**Query Syntax**        : GLOB: VOS? <pmt>

**Cmd/Rsp Syntax**     : GLOB: VOS <volts><pmt>

where <volts> is between -40.0 to +40.0

**Example**                : GLOB: VOS 1.3

**GLOB: VTH        Global Parameters—Threshold Voltage**

**Function**                Selects the global Volts Threshold for the global parameters function on the Setup Screen.

**Query Syntax**        : GLOB: VTH? <pmt>

**Cmd/Rsp Syntax** :GLOB:VTH <volts><pmt>  
 where <volts> is between -40.0 and +40.0

**Example** :GLOB:VTH -1.3

**:TEXT Channel Text Label**

**Function** Selects the text label for one or more channels.

**Query Syntax** :TEXT:<channel range>?<pmt>

**Cmd/Rsp Syntax** :TEXT:<channel range> <text><pmt>

where <text> is up to eight text characters enclosed within double quotes.

**Example** :TEXT:CH1\_2 "Chnl 1", "Chnl 2"

**:VG1:VFS Vglobal1 Full-Scale Voltage**  
**:VG2:VFS Vglobal2 Full-Scale Voltage**  
**:VG3:VFS Vglobal3 Full-Scale Voltage**

**Function** Select the Volts Full-Scale for the first, second, and third 'Vglobal' choice, respectively, for the global parameters function on the Setup Screen.

**Query Syntax** :VGx:VFS?<pmt>

**Cmd/Rsp Syntax** :VGx:VFS <volts><pmt>

where <volts> is between 1.0 and 10.0

**Example** :VG1:VFS 1.0

**:VG1:VOS Vglobal1 Offset Voltage**  
**:VG2:VOS Vglobal2 Offset Voltage**  
**:VG3:VOS Vglobal3 Offset Voltage**

**Function** Select the Volts Offset for the first, second, and third 'Vglobal' choice, respectively, for the global parameters function on the Setup Screen.

**Query Syntax** :VGx:VOS?<pmt>

**Cmd/Rsp Syntax** :VGx:VOS <volts><pmt>

where <volts> is between -40.0 and +40.0

**Example** :VG1:VOS -1.3

**:VG1:VTH           Vglobal1 Threshold Voltage**  
**:VG2:VTH           Vglobal2 Threshold Voltage**  
**:VG3:VTH           Vglobal3 Threshold Voltage**

**Function**                 Select the Volts Threshold for the first, second, and third 'Vglobal' choice, respectively, for the global parameters function on the Setup Screen.

**Query Syntax**            :**VGx:VTH?**<*pmt*>

**Cmd/Rsp Syntax**         :**VGx:VTH** <*volts*><*pmt*>  
 where <*volts*> is between -40.0 and +40.0

**Example**                 :**VG1:VTH 5**

**:VG1:TEXT           Vglobal1 Text Name Identifier**  
**:VG2:TEXT           Vglobal2 Text Name Identifier**  
**:VG3:TEXT           Vglobal3 Text Name Identifier**

**Function**                 Select the text name identifier for the first, second, and third 'Vglobal' choice, respectively, for the global parameters function on the Setup Screen.

**Query Syntax**            :**VGx:TEXT?**<*pmt*>

**Cmd/Rsp Syntax**         :**VGx:TEXT** <*text*><*pmt*>  
 where <*text*> is up to four ASCII text characters enclosed in double quotes.

**Example**                 :**VG1:TEXT "ECL"**

**:GEXE                Execute Global Change**

**Function**                 Sets variables based on selected global parameters and the global parameters value for the parameters. Functionally this command is the same as pressing the **Enter** key while in the Setup Screen Global Changes Menu.

## HARDWARE SETUP MESSAGES

### General

Hardware Setup messages consist of Commands, Queries, and Responses. Hardware setup Commands are sent to the device to select the hardware configuration for the next recording. Hardware setup Queries are sent to the device to request hardware setup Response Messages which inform the controller of the setting for requested parameters.

<i>Message Name</i>	<i>Description</i>
: ACQ : LIM	Recording time/cycle limit
: ACQ : MODE	Recording mode
: ACQ : VRES	Vertical resolution
: ACQ : PERS	Recording persistence select
: PROB : <group range>	Probe group mode select
: TIM : TDE	Time at left edge select
: TIM : TPD	Time per division select
: TLE : <channel range>	Channel trigger level select
: TRG : EVENT	Trigger event
: TRG : FILT	Trigger filter
: TRG : MODE	Trigger mode
: TRG : TLE	External trigger level select
: VFS : <channel range>	Channel Full-Scale voltage
: VOS : <channel range>	Channel Offset voltage
: VTH : <channel range>	Channel threshold voltage
: MEM	Next or Last Recording Parameters Set Select
: SET0?	Next recording setup query
: SET1?	Setup for recorded data query

## HARDWARE SETUP COMMANDS FORMAT

### : ACQ : LIM      Recording Time/Cycle Limit

<b>Function</b>	Selects the acquisition limit. The command data is parsed until a message separator or <pmt> is received. The acquisition limit may be specified as a time limit and/or cycle limit using 'T' (time limit), 'C' (cycle limit), and 'N' keywords. Omission of the 'T' keyword specifies no time limit; similarly, omission of the 'C' keyword specifies no cycle limit.
<b>Query Syntax</b>	: ACQ : LIM ? <pmt>
<b>Cmd/Rsp Syntax</b>	: ACQ : LIM <limit value> <pmt>
	where <limit value> is:
	T, <integer 0-99999>      to specify a TIME limit in seconds, 0 indicates no limit
	C, <integer 0-99999>      to specify a CYCLE limit, 0 for none
	N                              to specify NO LIMIT
<b>Example</b>	: ACQ : LIM T, 10, C, 20      Stop after 10 sec or 20 cycles, whichever comes first.



**:ACQ:LIM C,10** Stop after 10 cycles, no time limit.

**:ACQ:MODE Acquisition Mode**

**Function** Selects the acquisition mode as Scope ('s').

**Query Syntax** **:ACQ:MODE?<pmt>**

**Cmd/Rsp Syntax** **:ACQ:MODE <S><pmt>**

**Example** **:ACQ:MODE S**

**:ACQ:PERS Acquisition Persistence Mode**

**Function** Selects the persistence mode for the recording.

**Query Syntax** **:ACQ:PERS?**

**Cmd/Rsp Syntax** **:ACQ:PERS <pers><pmt>**

where <pers> is:

**I** for infinite persistence

**M** for minimum persistence

**Example** **:ACQ:PERS I**

**:ACQ:VRES Vertical Resolution**

**Function** Selects the vertical resolution as low resolution (four-bit mode) or high resolution (six-bit mode).

**Query Syntax** **:ACQ:VRES?<pmt>**

**Cmd/Rsp Syntax** **:ACQ:VRES <L OR H><pmt>**

**Example** **:ACQ:VRES L**

**:MEM Next or Last Recording Parameters Set Select**

**Function** Selects the set for accessing the hardware setup sets. Two copies of the hardware setup are maintained by the device. One set (mem 0) includes variables for the next recording; the second set (mem 1) includes the hardware setup for the acquisition data. The desired copy is selected using the :MEM command.

**Query Syntax** **:MEM?<pmt>**

**Cmd/Rsp Syntax** **:MEM <0 OR 1> <pmt>**

**Example** **:MEM 0**

**:PROB**                   **Probe Group Mode Select**

**Function**                   Selects the probe type and mode for one or more eight-channel groups.

**Query Syntax**             **:PROB:<group range>?<pmt>**

**Cmd/Rsp Syntax**         **:PROB:<group range> <pmt><pmt>**

where *<pmt>* is:

- s** (standard 8-channel mode)
- 2** (high-speed sampling, 2-channel 400 MHz mode)
- 1** (high-speed sampling, 1-channel 800 MHz mode)

**Example**                   **:PROB:GP1 S**

**:SET0?**                   **Next Recording Setup Query****:SET1?**                   **Acquisition Data Setup Query**

**Function**                   Requests device to respond with all hardware setup messages for the setup parameters for the next recording (mem 0), or the setup parameters for the acquired data (mem 1).

**Query Syntax**             **:SET0? or :SET1?**

**Cmd/Rsp Syntax**         All hardware setup messages are returned. Messages are grouped by category.

**Example**                   **:SET0?**  
**:ACQ:MODE S;:ACQ:LIM N;:ACQ:PERS M;...**  
**:PROB:...**  
**:TIM:...**  
 etc.

**:TIM:TDE**               **Time at Left Edge**

**Function**                   Selects the Time Left Edge for the Timing Display.

**Query Syntax**             **:TIM:TDE?<pmt>**

**Cmd/Rsp Syntax**         **:TIM:TDE <left edge><pmt>**

where *<left edge>* is -500 ms to 32 s; dependent on the time per division selected.

**Example**                   **:TIM:TDE -250 mS**

**:TIM:TPD**               **Time Per Division**

**Function**                   Selects the Time Per Division.

**Query Syntax**             **:TIM:TPD?<pmt>**

**Cmd/Rsp Syntax**         **:TIM:TPD <tpd><pmt>**

where *<tpd>* is between 1 ns and 50 ms (in 1, 2, 5 sequence).

**Example**                   :TIM:TPD 500 nS

### :TLE                   Channel Trigger Level

**Function**               Selects the Trigger Level for one or more channels.

**Query Syntax**         :TLE:<channel range>?<pmt>

**Cmd/Rsp Syntax**       :TLE:<channel range> <trigger><pmt>

where *<trigger>* is: L (low), H (high), X (don't care).

**Example**                   :TLE:CH1\_5 L,L,X,H,H

### :TRG:EVENT       Trigger Event

**Function**               Selects trigger event for the recording.

**Query Syntax**         :TRG:EVENT?<pmt>

**Cmd/Rsp Syntax**       :TRG:EVENT <tevent><pmt>

where *<tevent>* is:

T 0	(going True)
F 0	(going False)
T 1	(when True for < or > the filter time period)
F 1	(when False for < or > the filter time period)
T 2	(when the time between consecutive true edges is < or > the filter time period)
F 2	(when the time between consecutive false edges is < or > the filter time period)

**Example**                   TRG:EVENT T1

### :TRG:FILT       Trigger Filter

**Function**               Selects trigger filter qualifier and duration.

**Query Syntax**         :TRG:FILT?<pmt>

**Cmd/Rsp Syntax**       :TRG:FILT <tfqual>, <time value><pmt>

where *<tfqual>* is:

GT	(>, greater than), or,
LT	(<, less than)
<time value>	is 5 ns to 80 ms

**Example**                   :TRG:FILT LT,5.1 uS

### :TRG:MODE       Trigger Mode

**Function**               Selects trigger mode for the recording.

**Query Syntax** :TRG:MODE?<pmt>

**Cmd/Rsp Syntax** :TRG:MODE <tmode><pmt>

where <tmode> is N (normal), A (auto), or S (single).

**Example** :TRG:MODE N

### :TRG:TLE External Trigger Level Select

**Function** Selects external trigger logic level.

**Query Syntax** :TRG:TLE?<pmt>

**Cmd/Rsp Syntax** :TRG:TLE <trigger><pmt>

where <trigger> is L (low), H (high), X (don't care).

**Example** :TRG:TLE X

### :VFS Channel Full-Scale Voltage

**Function** Selects the Volts Full-Scale voltage for one or more channels.

**Query Syntax** :VFS:<channel range>?<pmt>

**Cmd/Rsp Syntax** :VFS:<channel range> <volts><pmt>

where <volts> is 1.0 to 10.

**Example** :VFS:CH1\_5 1.0,1,1,1,.5

### :VOS Channel Offset Voltage

**Function** Selects the volts offset for one or more channels.

**Query Syntax** :VOS:<channel range>?<pmt>

**Cmd/Rsp Syntax** :VOS:<channel range> <volts><pmt>

where <volts> is -40.0 to +40.0.

**Example** :VOS:CH1 -1.3

### :VTH Channel Threshold Voltage

**Function** Selects the Volts Threshold for one or more channels.

**Query Syntax** :VTH:<channel range>?<pmt>

**Cmd/Rsp Syntax** :VTH:<channel range> <volts><pmt>

where <volts> is between -40.0 and +40.0.

**Example** :VTH:CH1\_5 1.4,1.4,1.40,1.4,1.4

## DATA-RELATED MESSAGES

### General

Data-related Queries are sent to the device to request recorded data and acquisition parameters. The GPIB response data format select command (:DATA:FMT) allows the user to select the data format for the response to the Acquisition Data query as binary or ASCII hex data.

<i>Message Name</i>	<i>Description</i>
:DATA:CYC	Recording cycle count
:DATA:FMT	GPIB response data format select
:DATA:PAR	Acquisition Parameters
:DATA:TIM	Acquisition Run Time
:DATA:CH	Acquisition data

## DATA RELATED COMMANDS FORMAT

### :DATA:CYC Recording Cycle Count

**Function** Requests the number of cycles completed since the most recent start command.

**Query Syntax** :DATA:CYC?<pmt>

**Response Syntax** :DATA:CYC <#cycles><pmt>

where <#cycles> is an integer value.

**Example** :DATA:CYC?  
:DATA:CYC 3201

### :DATA:FMT GPIB Response Data Format

**Function** Selects the format for requested recorded data.

**Query Syntax** :DATA:FMT?<pmt>

**Cmd/Rsp Syntax** :DATA:FMT <format>,<separator choice><pmt>

where <format> is:

- H for ASCII HEX format
- B for binary format

where <separator choice> is:

- Y to select separator for ASCII records
- N to select no separator for ASCII records

**NOTE:** The *<separator choice>* selection is optional. If it is not included, NO SEPARATOR is used in formatting data.

**Example** :DATA:FMT B

### :DATA:PAR Acquisition Parameters

**Function** Requests acquisition parameters for the most recent recording. These parameters may also be retrieved by issuing the :MEM 1 command, followed by the appropriate SETUP queries.

**Query Syntax** :DATA:PAR?<pmt>

**Response Syntax** :DATA:PAR <mode><vertical res><pmt>

where <mode> is s for Scope

where <vertical res> is H for high resolution or L for low resolution.

**Sample Response** :DATA:PAR S,L

### :DATA:TIM Acquisition Run Time

**Function** Requests the run time, in seconds, since the most recent start command.

**Query Syntax** :DATA:TIM?<pmt>

**Response Syntax** :DATA:TIM <integer value>s<pmt>

**Sample Response** :DATA:TIM 3s

### :DATA:CH Acquisition Data

**Function** Requests acquired channel data.

**Query Syntax** :DATA:<channel range>:<sample range>?<pmt>

**Response Syntax** :DATA:<channel range>:<sample range>  
<mode>,<aux>,<#bytes>,<data><pmt>

where

<mode> is s for Scope

<aux> is H (for high resolution) or L (for low resolution)

<#bytes> is an ASCII encoded integer indicating the number of bytes which represent each sample in the <data>. This value is dependent on the data format (:DATA:FMT) and data resolution as follows:

*Low Resolution High Resolution**ASCII Hex* 4 bytes/sample 15 bytes/sample*Binary* 2 bytes/sample 8 bytes/sample

*<data>* is dependent on the data format and data resolution as follows:

#*H<channel sample data>* for ASCII HEX format

#*<digit count><total bytes><channel sample data>* for binary format

*<digit count>* is a single integer (1-9) indicating the total number of digits in the *<total bytes>*.

*<total bytes>* indicates the number of binary bytes following which represent the channel sample data.

*<channel sample data>* is ordered as follows:

*<first channel/first sample>...<first channel/last sample>*

*<second channel/first sample>...<second channel/last sample>*

*<last channel/first sample>...<last channel/last sample>*

The *<channel sample data>* format is described below for the four vertical resolution/data format modes.

**Query Example** :DATA:CH1:SN1\_2?

**Sample Response** :DATA:CH1:SN1\_2 S,L,4,#H1800,3000 (lo res/hex)

**Sample Response** :DATA:CH1:SN1\_2 S,L,2,#1418003000 (lo res/binary)

The underlined characters above are sent as raw binary values but are shown in ASCII-encoded HEX for simplicity in this example. All other characters are sent in their ASCII representations.

## CHANNEL SAMPLE DATA FORMAT

Note that in Infinite Persistence mode, more than one level may be asserted in each sample, indicating changes in the waveform over time.

For Minimum Persistence recordings, only the most recently-recorded level is represented in each sample.

## Scope Mode, Low Resolution

The Low Resolution mode gives 16 levels of vertical resolution for each sample.

	<i>Bit7</i>	<i>Bit6</i>	<i>Bit5</i>	<i>Bit4</i>	<i>Bit3</i>	<i>Bit2</i>	<i>Bit1</i>	<i>Bit0</i>
<i>Byte 0</i>	Over	Lvl15	Lvl14	Lvl13	Lvl12	Lvl11	Lvl10	Lvl09
<i>Byte 1</i>	Lvl08	Lvl06	Lvl05	Lvl04	Lvl03	Lvl02	Lvl01	Under

For **Binary**, there are two bytes sent per sample (Sample Byte 0, then Byte 1).

For **ASCII hex**, there are four bytes sent per sample (Encoded Byte 0, then Byte 1).

**Example**                      Binary                      [00000001][00000011][00000010]  
    Hex                                      010302

## Scope Mode, High Resolution

The High Resolution mode gives 60 levels of vertical resolution for each sample.

	<i>Bit7</i>	<i>Bit6</i>	<i>Bit5</i>	<i>Bit4</i>	<i>Bit3</i>	<i>Bit2</i>	<i>Bit1</i>	<i>Bit0</i>
<i>Byte 0</i>	0	0	0	0	Lvl59	Lvl58	Lvl57	Lvl56
<i>Byte 1</i>	Lvl55	Lvl54	Lvl53	Lvl52	Lvl51	Lvl50	Lvl49	Lvl48
<i>Byte 2</i>	Lvl47	Lvl46	Lvl45	Lvl44	Lvl43	Lvl42	Lvl41	Lvl40
<i>Byte 3</i>	Lvl39	Lvl38	Lvl37	Lvl36	Lvl35	Lvl34	Lvl33	Lvl32
<i>Byte 4</i>	Lvl31	Lvl30	Lvl29	Lvl28	Lvl27	Lvl26	Lvl25	Lvl24
<i>Byte 5</i>	Lvl23	Lvl22	Lvl21	Lvl20	Lvl19	Lvl18	Lvl17	Lvl16
<i>Byte 6</i>	Lvl15	Lvl14	Lvl13	Lvl12	Lvl11	Lvl10	Lvl09	Lvl08
<i>Byte 7</i>	Lvl07	Lvl06	Lvl05	Lvl04	Lvl03	Lvl02	Lvl01	Under

For **Binary**, eight bytes are returned (Bytes 0,1,2,3,4,5,6,7).

For **ASCII hex**, 15 characters are returned. The upper four bits of Byte 0 are not included.

# ANALYZER CONTROL FUNCTIONS

## General

The **Commands** and **Queries** for Analyzer Control Functions allow the user to remotely control and determine the recording status of the device.

<i>Message Name</i>	<i>Description</i>
: <b>CLEAR</b>	Clear all channels
: <b>CLRREF</b>	Clear Reference data
: <b>GO</b>	Start acquisition
: <b>RFSH</b>	Refresh screen display
: <b>START</b>	Start acquisition



: STAT?	System status query
: STOP	Stop acquisition
: STORE	Store data to reference

## ANALYZER CONTROL COMMANDS FORMAT

### : CLEAR            Clear Acquisition Buffer Command

**Function**            Clears the acquisition buffer.

**Command Syntax**    :CLEAR <*pmt*>

### : CLRREF           Clear Reference Data Command

**Function**            Clears the reference buffer.

**Command Syntax**    :CLRREF <*pmt*>

### : GO : START            Start Acquisition Command

**Function**            Initiate a record cycle.

**Command Syntax**    :GO<*pmt*>  
:START<*pmt*>

### : RFSH            Screen Refresh Command

**Function**            The RFSH command instructs the unit to refresh and update the screen. In order to provide faster throughput, the K1600 screen is not automatically updated as each setup command is received. Only the receipt of the GO, RFSH, or START command causes the screen to be updated when operating in remote mode.

**Command Syntax**    :RFSH <*pmt*>

### : STAT?            Current Device Status Query

**Function**            The STAT? query requests the current status for the unit.

**Query Syntax**        :STAT?<*pmt*>

**Response Syntax**    :STAT <*status*><*pmt*>

where <*status*> is the ASCII status message which is displayed in the upper-right-hand corner of the display.

**Example Resp**        :STAT    READY

### :STOP            Stop Acquisition Command

**Function**            The STOP command terminates the current recording.

**Command Syntax** :STOP <pmi>

### **:STORE Store Data to Reference Command**

**Function** The STORE command copies the recorded data to the reference buffer.

**Command Syntax** :STORE <pmi>

## DEVICE STATUS REPORTING

### General

Four registers are used to report the status of the device: Status Byte Register, Service Request Enable Register, Standard Event Status Register, and Standard Event Status Enable Register.

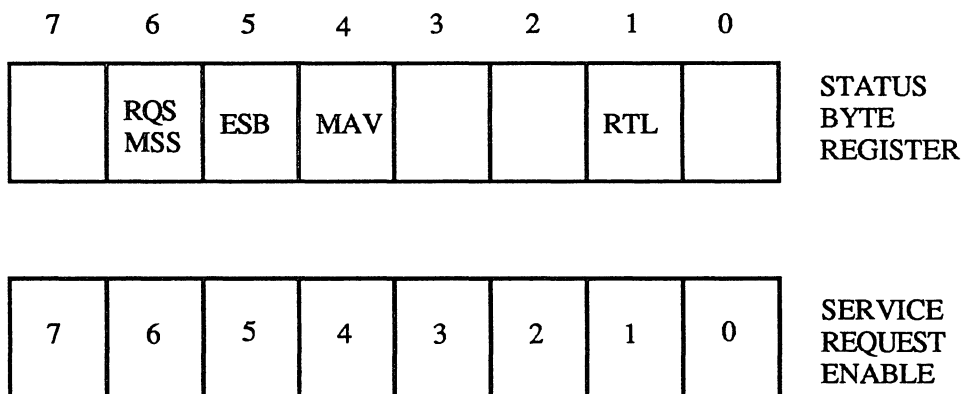

**Figure 10-3. Status Byte and Service Request Enable Registers**

### Status Byte Register

The Status Byte Register (Figure 10-3) consists of seven summary bits. Each summary bit tracks the current status of its associated Status Data Structure.

- RQS** Request for Service bit. This bit is returned during a serial poll and is cleared following the serial poll.
- MSS** Master Summary Status bit. Indicates whether the device has a reason for requesting service. This bit is the inclusive OR of the bitwise combination (excluding bit6) of the Status Byte Register and the Service Request Enable Register.
- ESB** Event Status Bit. TRUE if an enabled event in the Standard Event Status Register is set TRUE. FALSE if no enabled events are TRUE.

**MAV** Message available. Indicates whether or not the Output Queue is empty.

**RTL** Remote to local transition occurred.

The **Status Byte Register** is maintained by the device and is not directly programmable by the user. The contents of the Status Byte register are read by a serial poll or by issuing the `*STB?` query. The Status Byte register is cleared on receipt of the `*CLS` command.

### Service Request Enable Register

The **Status Byte Enable Register** is initialized to 0 on device powerup and is written with the `*SRE` command (`*SRE <integer 0-255>`) and read back with the `*SRE?` query.

### Standard Event Status Register

The bits of the Standard Event Status Register are ANDed with corresponding bits of the Standard Event Status Enable Register (Figure 10-4). The resulting byte is ORed together and reported in the ESB bit of the Status Byte Register.

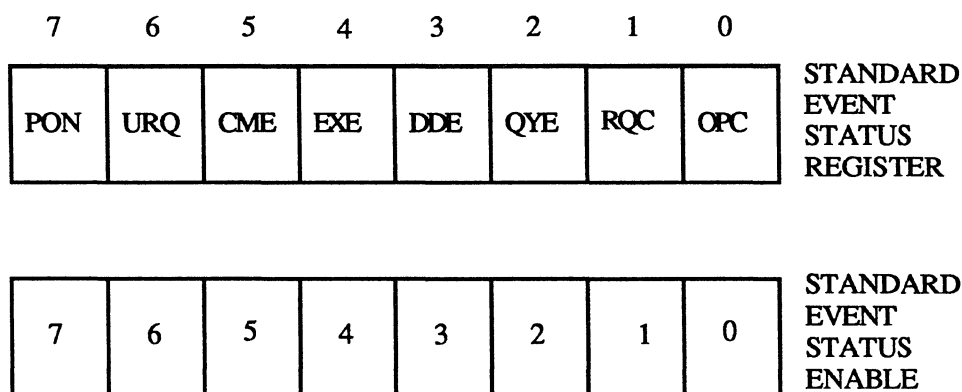

**Figure 10-4. Standard Event Status and Enable Registers**

**PON** Power On. Indicates an off-to-on transition in the power supply.

**URQ** User Request. Indicates when a front panel **Help** key has been pressed.

**CME** Command Error. Indicates when a syntax error is detected by the parser.

**EXE** Execution Error. Indicates when a parameter is received which is out of range for the present configuration.

**DDE** Device Dependent Error. Indicates whether an operation could not be completed due to some error condition which would not cause a command, execution or query error.

- QYE** Query Error. Indicates whether an attempt to read the output queue was made when no data was present.
- RQC** Request Control. Indicates whether the device is requesting control. Always set to 0.
- OPC** Operation Complete. Indicates whether the device has completed all pending operations. Generated in response to the \*OPC command when device has completed all selected pending operations.

The **Standard Event Status Register** is destructively read with the \*ESR? query and is also cleared on receipt of the \*CLS command.

The **Standard Event Status Enable Register** is initialized to 0 on powerup, read with the common query, \*ESE?, and is written to by the common command, \*ESE.

## SYNCHRONIZATION TECHNIQUES

### Query/Readback

When the controller is expecting a response from the device, two methods may be used to retrieve the response.

- 1 The controller may address the device to talk and wait for the response. This is not desirable as the bus will be locked up until the device is ready to respond.
- 2 Alternatively, the controller may serial poll the device until the status byte MAV bit is asserted. This may be accomplished with or without service request interrupts. If service requests are used, the service request enable register must be set appropriately with bit 4 enabled. Once the MAV bit is detected, indicating the device is ready to respond, the controller may address the device to talk and read the message.

### Operation Complete

Two methods may be used to determine when a recording is completed. It should be noted that, in normal operation, the device automatically re-arms after each recording until the :STOP command is received. The user may define a limit condition using the :ACQ:LIM command to program a stop condition on completion of  $x$  record cycles or after a specified time limit.

Once the recording is started, the \*OPC? query may be issued. This query requests the device to output an ASCII 1 when the recording is complete. The user may serial poll or request the response as described above.

Controller to device: \*CLS

Controller to device: :go

Controller to device: **\*OPC?**  
 [wait for MAV bit in Status Byte]  
 [Controller address device to talk]

Device to Controller: **1**

Alternatively, the **\*OPC** command may be issued after the recording is started. This command instructs the device to set the OPC bit in the Standard Event Status Register when the recording is complete. One way to determine when this bit has been set is to first set the related Standard Event Status Enable Register bit. Thus, when the OPC bit is set, the ESB bit in the Status Byte Register will also be set and the user can perform a serial poll to read this back.

Controller to device: **\*CLS; \*ESE 1**

Controller to device: **:go; \*OPC**  
 [wait for ESB bit in Status Byte]

Controller to device: **\*ESR?**  
 [wait for MAV bit in Status Byte]  
 [Controller address device to talk]

Device to Controller: **1**

## INDEX OF COMMANDS

### GPIB COMMON COMMANDS

<i>Name</i>	<i>Description</i>	<i>Page</i>
<b>*CLS</b>	Clear Status Command . . . . .	10-6
<b>*ESE</b>	Standard Event Status Enable Command . . . . .	10-6
<b>*ESE?</b>	Standard Event Status Enable Query . . . . .	10-6
<b>*ESR?</b>	Standard Event Status Register Query . . . . .	10-6
<b>*IDN?</b>	Identification Query . . . . .	10-6
<b>*OPC</b>	Operation Complete Command . . . . .	10-6
<b>*OPC?</b>	Operation Complete Query . . . . .	10-6
<b>*RST</b>	Reset Command . . . . .	10-7
<b>*SRE</b>	Service Request Enable Command . . . . .	10-7
<b>*SRE?</b>	Service Request Enable Query . . . . .	10-7
<b>*STB?</b>	Read Status Byte Query . . . . .	10-7
<b>*TST?</b>	Self-Test Query . . . . .	10-7
<b>*WAI</b>	Wait-to-Continue Command . . . . .	10-7

## DISPLAY SETUP COMMANDS

<i>Name</i>	<i>Description</i>	<i>Page</i>
:COL:<channel range>	Channel trace display color . . . . .	10-11
:CURS:JTIM	J-cursor value . . . . .	10-11
:CURS:KTIM	K-cursor value . . . . .	10-11
:CURS:LCV	L-amplitude cursor value . . . . .	10-11
:CURS:LE	L-amplitude cursor channel select . . . . .	10-12
:CURS:MCV	M-amplitude cursor value . . . . .	10-12
:CURS:ME	M-amplitude cursor channel select . . . . .	10-12
:DISP:MODE	Display Mode—Analog or Digital . . . . .	10-12
:DISP:ONS	Number of traces on screen . . . . .	10-12
:DISP:ORG	Display organization Seq/Overlay . . . . .	10-13
:DISP:PAR	Timing display parameter choice . . . . .	10-13
:DISP:SCR	Display screen select . . . . .	10-13
:DISP:SEQ:<seqn range>	Timing display channel display sequence . . . . .	10-13
:DISP:TOP	Index of top trace in sequence on timing screen . . . . .	10-14
:DISP:VIH:<channel range>	High logic level—Time chart display mode . . . . .	10-14
:DISP:VIL:<channel range>	Low logic level—Time chart display mode . . . . .	10-14
:GLOB:COL	Global parameters—trace color select . . . . .	10-14
:GLOB:END	Global parameters—end channel select . . . . .	10-14
:GLOB:PAR	Global parameters—parameter select . . . . .	10-15
:GLOB:STA	Global parameters—starting channel . . . . .	10-15
:GLOB:TEXT	Global parameters—trace text label . . . . .	10-15
:GLOB:TLE	Global parameters—channel trigger level . . . . .	10-15
:GLOB:VFS	Global parameters—channel full-scale voltage . . . . .	10-16
:GLOB:VG	Global parameters—Vglobal select . . . . .	10-16
:GLOB:VOS	Global parameters—channel offset voltage . . . . .	10-16
:GLOB:VTH	Global parameters—channel threshold voltage . . . . .	10-16
:TEXT:<channel range>	Channel text label . . . . .	10-16
:VG1:TEXT	Vglobal1 text name identifier . . . . .	10-17
:VG1:VFS	Vglobal1 channel full-scale voltage . . . . .	10-17
:VG1:VOS	Vglobal1 channel offset voltage . . . . .	10-17
:VG1:VTH	Vglobal1 channel threshold voltage . . . . .	10-17
:VG2:TEXT	Vglobal2 text name identifier . . . . .	10-17
:VG2:VFS	Vglobal2 channel full-scale voltage . . . . .	10-17
:VG2:VOS	Vglobal2 channel offset voltage . . . . .	10-17
:VG2:VTH	Vglobal2 channel threshold voltage . . . . .	10-17
:VG3:TEXT	Vglobal3 text name identifier . . . . .	10-17
:VG3:VFS	Vglobal3 channel full-scale voltage . . . . .	10-17
:VG3:VOS	Vglobal3 channel offset voltage . . . . .	10-17
:VG3:VTH	Vglobal3 channel threshold voltage . . . . .	10-17
:GEXE	Execute Global Changes . . . . .	10-18

## HARDWARE SETUP COMMANDS

<i>Name</i>	<i>Description</i>	<i>Page</i>
:ACQ:LIM	Recording time/cycle limit . . . . .	10-20
:ACQ:MODE	Recording mode . . . . .	10-20
:ACQ:VRES	Vertical resolution . . . . .	10-20
:ACQ:PERS	Recording persistence select . . . . .	10-20
:MEM	Next or Last Recording Parameters Set Select	10-21
:PROB:<group range>	Probe group mode select . . . . .	10-21
:SET0?	Next recording setup query . . . . .	10-21
:SET1?	Setup for recorded data query . . . . .	10-21
:TIM:TDE	Time at left edge select . . . . .	10-21
:TIM:TPD	Time per division select . . . . .	10-22
:TLE:<channel range>	Channel trigger level select . . . . .	10-22
:TRG:EVENT	Trigger event . . . . .	10-22
:TRG:FILT	Trigger filter . . . . .	10-22
:TRG:MODE	Trigger mode . . . . .	10-23
:TRG:TLE	External trigger level select . . . . .	10-23
:VFS:<channel range>	Channel full-scale voltage . . . . .	10-23
:VOS:<channel range>	Channel offset voltage . . . . .	10-23
:VTH:<channel range>	Channel threshold voltage . . . . .	10-23

## DATA RELATED COMMANDS

<i>Name</i>	<i>Description</i>	<i>Page</i>
:DATA:CYC	Recording cycle count . . . . .	10-25
:DATA:FMT	GPIB response data format select . . . . .	10-25
:DATA:PAR	Acquisition Parameters . . . . .	10-25
:DATA:TIM	Acquisition Run Time . . . . .	10-25
:DATA:CH	Acquisition data . . . . .	10-26

## ANALYZER CONTROL COMMANDS

<i>Name</i>	<i>Description</i>	<i>Page</i>
:CLEAR	Clear all channels . . . . .	10-29
:CLRREF	Clear Reference data . . . . .	10-29
:GO	Start acquisition . . . . .	10-29
:RFSH	Refresh screen display . . . . .	10-29
:START	Start acquisition . . . . .	10-29
:STAT?	System status query . . . . .	10-29
:STOP	Stop acquisition . . . . .	10-29
:STORE	Store data to reference . . . . .	10-29

## Appendix A

# K1600 SPECIFICATIONS

---

## ACQUISITION

<b>Number of Channels</b>	16
<b>Analog Bandwidth</b>	350 MHz (at the probe tip)
<b>Time Resolution</b>	50 ps repetitive (20 GHz equivalent sampling) 1.25 ns single shot (800 Msamples/sec probe pod) 2.5 ns single shot (400 Msamples/sec probe pod) 10 ns single shot (100 Msamples/sec standard probes)
<b>Input Impedance</b>	50 k $\Omega$ , 2 pF (at the probe tip)
<b>Amplitude Resolution</b>	6 bits repetitive (nominal) 4 bits single-shot
<b>Full-Scale Sensitivity</b>	1 V to 10 V in 0.1 V steps
<b>Input Offset</b>	-40 V to +40 V in 0.1 V steps
<b>Trigger Threshold</b>	-40 V to +40 V in 0.1 V steps
<b>Time Per Division</b>	1 ns to 50 ms, adjustable in 1, 2, 5 sequence
<b>Trigger Delay</b>	-500 ms to 32 sec at 50 ms/div -10 $\mu$ s to 640 $\mu$ s at 1 ns/div
<b>Memory Depth</b>	1000 samples per channel

## TRIGGERING

<b>Description</b>	Combinational triggering across all channels, selected as H (high), L (low), or X (don't care) for each channel
<b>Trigger Width</b>	3 ns minimum overlap
<b>External Trigger</b>	BNC, rear panel, TTL levels, combined with data channels, selected as H, L, or X
<b>Trigger Modes</b>	Normal, Single-shot, Auto
<b>Time Filter</b>	Time duration qualifier applied to the combinational trigger word
<b>Time Filter Range</b>	5 ns to 80 ms



<b>Time Filter Resolution</b>	1 ns steps from 5 ns to 100 ns 5 ns steps from 100 ns to 500 ns 1% above 500 ns
<b>Time Filter Choices</b>	Trigger going true (filter off) Trigger going false (filter off) Trigger true > or < filter time Trigger false > or < filter time Time between consecutive true trig > or < filter time Time between consecutive false trig > or < filter time

## DISPLAY

<b>Trace Display Modes</b>	2, 4, 8, or 16 channels displayed, can be either sequentially, or in 1, 2, 4 or 8 overlays
<b>Trace Sequence</b>	Traces can be displayed in any sequence, traces can be displayed multiple times, traces can be inserted and deleted
<b>Trace Persistence</b>	Minimum, infinite
<b>Time Chart Display</b>	User defined high and low logic thresholds, analog signal displayed in time chart (timing diagram) format, signals can be overlaid giving bus display with state readout
<b>Trace Labels</b>	Up to 8 characters per trace
<b>User Screens</b>	Timing, setup, disk, more (utility), help (active field)
<b>Reference Memory</b>	Store to reference, clear reference

## PROBES

<b>Standard Input Probe</b>	350 MHz bandwidth 50 k $\Omega$ , 2 pF impedance 8 channels x 100 Msamples/sec 6 feet long
-----------------------------	---

## I/O INTERFACE

<b>Video out</b>	VGA compatible, supports external color monitor
<b>Printer</b>	RS-232, 9-pin serial port connector Standard 25-pin parallel port connector compatible with Centronics printer interface

<b>Power (Level Converter)</b>	LEMO connector, +5 V at 1 A, -5 V at 1 A, GND
<b>High-Speed Probe</b>	Two 9-pin D-type connectors, power and offset control for two high-speed probe pods
<b>Trigger Input</b>	BNC, rear panel, TTL levels, combined with data channels to define combinational trigger
<b>Enable Input</b>	BNC, rear panel, TTL levels, pulled high internally, enables the K1600 to start looking for the trigger, drive low to disable
<b>Qualified Trigger Out</b>	BNC, rear panel, TTL levels, normally low, pulses high every time a time qualified trigger is found
<b>System Trigger Out</b>	BNC, rear panel, TTL levels, normally low, driven high during data upload, signals every trigger that causes a screen update
<b>Buffered Data</b>	Dual row 34-pin header, ECL levels, buffered copy of 16 data inputs and external trigger input, single ended, top row of header is GND, bottom row is SIG. This buffered data header can be used in conjunction with the enable input to expand the trigger capability of the instrument.
<b>Calibration</b>	Dual row 20-pin header, ECL levels, nine time-aligned copies of square wave for probe deskew calibration, single-ended, top row of header is AGND, bottom row is SIG (right-hand pin on bottom row is also AGND)

## STORAGE

<b>Nonvolatile SRAM</b>	Last setup is stored in nonvolatile SRAM, restored on power up
-------------------------	--

## OPTIONS

<b>800 MSample Probe Pod</b>	250 MHz bandwidth 26 k $\Omega$ , 6 pF impedance 1 channel x 800 Msamples/s, or 2 channels x 400 Msamples/s 6 feet cable length
<b>Disk storage</b>	1.44 Mbyte, 3.5" disk drive, DOS-compatible disk files, store setups and/or data.
<b>Hard disk drive</b>	40 Mbytes
<b>GPIB control</b>	
<b>External color monitor</b>	(Rear-panel connector is standard)

<b>Internal color monitor</b>	(This option not available at time of printing)
<b>ASCII External Keyboard</b>	
<b>PC-based utilities</b>	To view and analyze acquired data on a PC

## **MECHANICAL**

<b>Unit Dimensions (H x W x D)</b>	7.5 x 16.0 x 18 inches (19.0 x 40.5 x 45.7 cm)
<b>Weight</b>	40 lbs (18.2 kg) approximate
<b>Power</b>	Universal supply, 90-240 VAC, 50-60 Hz, 350 watts

# INDEX

---

If a topic covers two or more pages, the index lists only the first page.

2nd key, 3-6  
800 MSample Probe, 2-22, 9-1  
    Applications, 9-2  
    Menu setup, 9-5  
    Optimizing the display, 9-6  
    Probe setup, 9-4  
    Specifications, 9-8  
    Theory of operation, 9-3

## A

AC connector, 7-7  
AC power switch, 3-8  
Analog/Digital Display Mode, 4-20  
Analog features, 1-4  
Applications  
    ATE, 1-3  
    Benchtop, 1-2  
ASCII keyboard, 1-7, 7-4, 9-9  
ATE applications, 1-3  
Autosave, 4-2, 5-2

## B

Basic measurements, 2-6  
Benchtop applications, 1-2  
Buffered data outputs, 7-6  
Bus Display 8-7

## C

Changing the display, 2-14  
Channel and display parameters,  
    4-10, 5-4  
Channel selection, 4-11, 5-4  
Channel Text Label, 4-16, 5-6  
Channel trace color, 4-15, 5-6  
Channel Trigger Level, 4-13, 5-7  
Channel Vertical Position, 4-18

Channel Volts Full-Scale, 4-12,  
    5-4  
Channel Volts Offset, 4-13, 5-5  
Channel Volts Threshold, 4-14,  
    5-5  
Clear keys, 3-6  
Clear Reference Memory  
    function, 8-4  
Color display, 4-15, 7-4  
Color traces, 4-15, 5-6  
Cooling fans, 7-7  
CRT display, 3-2, 4-16, 7-4  
Cursor measurements, 4-21  
Cursor movement keys, 3-5  
Cursor operation, 4-20

## D

Data outputs, 7-6  
Decrement key, 3-5  
Default Setup File, 6-3, 6-6  
Delete a file, 6-4  
Digital-display Mode, 2-18, 4-20  
Digital features, 1-4  
Directory sorting, 6-7  
Disk drive, 3-8  
Disk drive selection, 6-8  
Disk formatting, 6-7  
Disk functions, 2-19, 3-8, 6-4  
Disk purchase and formatting, 6-8  
Disk Screen, 6-1  
    Content, 6-2  
Display, 3-2  
Display Area Indicator, 4-8  
Drive selection, 6-8

## E

End Channel field, 5-9  
Erase a file, 6-4  
External color display, 4-15, 7-4

External keyboard, 1-7, 7-3, 9-9  
External keyboard connector, 7-3

## F

Fans, 7-7  
Features  
    Analog, 1-4  
    Digital, 1-4  
    Menu and display, 1-5  
    Other, 1-7  
    Trigger, 1-4  
Field display, 4-12  
FILE selection, 8-9  
Filter disk directory, 6-4  
Floppy disk drive, 3-8  
Format disks, 6-7  
Front panel, 3-1  
    Layout, 2-4, 3-1  
    Overview, 2-3, 3-1  
Function keys, 3-6

## G

Getting started, 2-1  
Global Changes, 5-8  
Global Parameters field, 5-9  
Global Value field, 5-9  
 GPIB, 9-10, 10-1  
    Analyzer control functions,  
        10-29, 10-36  
    Assign value for range of  
        elements, 10-6  
    Cable connections, 10-1  
    Channel sample data format,  
        10-28  
    Common commands, 10-6,  
        10-34  
    Communication protocol, 10-3  
    Compound message headers,  
        10-5

Data-related messages, 10-26, 10-36  
Device-specific messages, 10-9  
Device status reporting, 10-31  
Display setup messages, 10-11, 10-35  
Hardware setup messages, 10-20, 10-36  
Index of commands, 10-34  
Local Mode, 10-3  
Message syntax, 10-4  
Multiple message units, 10-5  
Operation, 10-1  
Operation Complete, 10-33  
Query/Readback, 10-33  
Remote/local operation, 10-3  
Remote Mode, 10-3  
Scope Mode, High Resolution, 10-29  
Scope Mode, Low Resolution, 10-29  
Service Request Enable Register, 10-32  
Special characters, 10-4  
Standard Event Status Register, 10-32  
Startup, 10-2  
Status Byte Register, 10-31  
Synchronization techniques, 10-33  
User reference data, 10-6  
 GPIB Connector, 7-6, 10-1  
 GPIB parameters, 8-11

## H

Hardcopy output, 8-9  
Hard disk drive, 6-1, 9-9  
Hardware setup, 2-3  
High-speed Probe, *see*  
 800 MSample Probe  
Horizontal indicator bars, 4-7  
How to use this manual, 1-8

## I

IEEE-488 Connector, 7-4  
Increment key, 3-5

Initial setup, 2-2  
Input probe connectors, 7-1  
Input probes, 1-6  
Intensity Control, 7-2  
Interference, *iv*  
Internal hard disk drive, 9-9  
I/O Setup Menu, 8-2

## K

Keyboard, 1-7, 7-3, 9-9  
Keyboard Connector, 7-3  
Keypad, 3-3

## L

Labels, 4-16, 5-6  
Load a file from disk, 6-5  
Load Default Setup File, 6-6  
Logic Levels, 8-5  
Logic Levels Menu, 8-4

## M

Measuring signals, 2-8  
Memory size bars, 4-7  
Menu fields, 4-3, 5-2  
Menu setup and data storage, 1-7  
Menu and display features, 1-5  
Mode selection, 4-3, 5-3  
More key, 2-20, 8-1  
More Options Menu, 8-1

## N

Next/Previous keys, 3-5  
Number of channel displayed, 4-19  
Number/Units keys, 3-5

## O

Operating keys, 3-6  
Options and accessories, 1-7, 9-1  
 800 MSample Probe, 2-22, 9-1

External keyboard, 9-9  
 GPIB, 9-10, 10-1  
Hard disk drive, 9-9  
Overlaid Trace Display, 8-7  
Overlay field, 4-19

## P

Parallel (Centronics) Connector, 7-7  
PARALLEL port selection, 8-11  
Persistence field, 4-13  
Power Input Connector, 7-7  
Power switch, 3-8, 7-7  
Previous key, 3-5  
Print function, 8-11  
 Procedure, 8-12  
 Screen contents to printer, 8-11  
 Screen contents to file, 8-12  
Printing files from external PC, 8-12  
Probe Selection Menu, 8-3

## Q

Qualified Trigger Output, 7-5

## R

Rear panel, 7-1  
Reference waveforms, 2-21  
Reference memory, 8-3  
RS-232 parameters, 8-10  
RS-232 port selection, 8-9  
RS-232 Serial Connector, 7-7

## S

Saving setups and data, 6-6  
Screen features, 2-10  
Screen layout, 4-2  
Scroll keys, 3-4  
Scroll knob, 3-7  
Sequence/Overlay, 4-19

Setup and Timing Screen interaction, 5-2  
Setup File, 6-6  
Setup Menu parameters, 2-8  
Setup Screen, 5-1  
    Layout, 5-2  
    Menu fields, 5-2  
Signal connections, 7-6  
Sorting the directory, 6-7  
Special operating features, 8-1  
Specifications, A-1  
Start Channel field, 5-9  
Start/Stop/Clear keys, 3-6  
Status Window, 4-6, 5-3  
Stop Conditions Menu, 8-6  
Stop key, 3-6  
Store displayed data, 8-3  
Store Reference Memory function, 8-3  
Switches and controls, 7-1, 7-2  
System Trigger Output, 7-5

## T

Text Labels, 4-16, 5-6  
Time Chart Bus Display, 8-7  
Time Chart Display, 8-7  
Time-chart Mode, 2-19, 8-7  
Time fields, 4-8, 5-4  
Time Left Edge, 4-8, 5-4  
Time Per Division, 4-9, 5-4  
Timing cursors, 2-15, 4-21  
Timing Menu setup, 2-10  
Timing Screen, 4-1  
    Layout, 4-2  
    Menu fields, 4-3  
Trace color, 4-15, 5-6  
Trigger, 2-12  
    Features, 1-4  
    Selection, 4-4  
Trigger Connectors, 7-5  
Trigger Enable, 7-5  
Trigger Event, 4-5, 5-3  
Trigger Filter Duration, 4-5, 5-3  
Trigger Filter Qualifier, 4-5, 5-3  
Trigger Input, 7-5  
Trigger Level, 4-13, 5-7  
Trigger Mode, 4-4, 5-3  
Trigger outputs, 7-5  
Trigger Selection, 4-4

Trigger threshold field, 2-17  
Tutorial, 2-1

## U

Units keys, 3-5  
Update the directory, 6-4

## V

Vertical indicator bar, 4-8  
Vertical Position, 4-18  
Vertical resolution, 4-3, 5-2  
VGA color display, 4-15, 7-4  
Vglobal, 5-10  
Video Output Connector, 7-4  
Vil and Vih logic transitions, 8-5  
Voltage cursors, 2-16, 4-20  
Volts Full-Scale, 4-12, 5-4  
Volts Offset, 4-13, 5-5  
Volts Threshold, 4-14, 5-5

## W

Waveform display characteristics,  
4-18

1

2

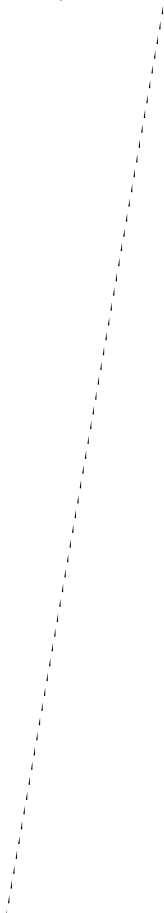



NO POSTAGE  
NECESSARY  
IF MAILED  
IN THE  
UNITED STATES

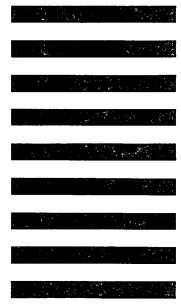

**BUSINESS REPLY MAIL**  
FIRST CLASS MAIL PERMIT NO. 200719 SAN JOSE CA

POSTAGE WILL BE PAID BY ADDRESSEE



1860 Barber Lane  
Milpitas CA 95035-7422



NO POSTAGE  
NECESSARY  
IF MAILED  
IN THE  
UNITED STATES

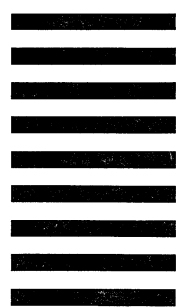

**BUSINESS REPLY MAIL**  
FIRST CLASS MAIL PERMIT NO. 200719 SAN JOSE CA

POSTAGE WILL BE PAID BY ADDRESSEE



1860 Barber Lane  
Milpitas CA 95035-7422





## Warranty/Registration



1860 Barber Lane  
Milpitas CA 95035-7422  
800-934-2466 • 408/435-7800  
FAX 408/435-7970

Please return this card to BIOMATION within five days.

- Did the packaging of this equipment exhibit any outward signs of physical damage? . . . . . YES  NO
- Did this equipment arrive intact, without missing parts, loose parts or cable damage? . . . . . YES  NO
- Did the equipment operate on power-up? . . . . . YES  NO
- Did you attain adequate system performance? . . . . . YES  NO
- Were any electrical adjustments required? . . . . . YES  NO
- If you required assistance, was a local BIOMATION representative contacted? . . . . . YES  NO

Comments \_\_\_\_\_

User Name \_\_\_\_\_ Title \_\_\_\_\_ Department \_\_\_\_\_ M/S \_\_\_\_\_

Company \_\_\_\_\_ Phone \_\_\_\_\_

Address \_\_\_\_\_ City \_\_\_\_\_ State \_\_\_\_\_ Zip \_\_\_\_\_

Model or Description \_\_\_\_\_ Serial or Part No. \_\_\_\_\_ Date Received \_\_\_\_\_

## Reader Comments



1860 Barber Lane  
Milpitas CA 95035-7422  
800-934-2466 • 408/435-7800  
FAX 408/435-7970

The manual's completeness, accuracy, organization, usability, and reliability \_\_\_\_\_

\_\_\_\_\_

Did you find errors in this manual? \_\_\_\_\_ How can this manual be improved? \_\_\_\_\_

\_\_\_\_\_

Additional comments \_\_\_\_\_

\_\_\_\_\_

Name \_\_\_\_\_ Department \_\_\_\_\_ Date \_\_\_\_\_

Company \_\_\_\_\_ Manual or Part No \_\_\_\_\_

Address \_\_\_\_\_

City \_\_\_\_\_ State \_\_\_\_\_ Zip \_\_\_\_\_ Phone \_\_\_\_\_



