

XEROX

**OPERATOR MANUAL
Book One - Full Page**

860 INFORMATION PROCESSING SYSTEM

Appreciation is expressed for the help of International Paper Company in the preparation of this manual, portions of which are drawn from its publication, Pocket Pal - A Graphic Arts Production Handbook, Tenth Edition, June 1970.

Warning: This equipment generates and uses radio frequency energy and if not installed and used properly; i.e., in strict accordance with the instruction manual, may cause harmful interference to radio communications. It has been tested and found to comply with the limits for a Class A computing device pursuant to Subpart J of Part 15 of FCC Rules, which are designed to provide reasonable protection against such interference when operated in a commercial environment.

Operation of this equipment in a residential area is likely to cause interference in which case the user, at his own expense, will be required to take whatever measures may be required to correct the interference.

860 INFORMATION PROCESSING SYSTEM

OPERATOR MANUAL Book One - Full Page

LESSON ONE	Pages
Introduction	
Training Materials: What You Will Need	1- 2
Starting to Use the System	1- 9
Typing a New Document	1-22
Using the Diagnostic Panel and Disc	1-29
Turning Off the 860	1-30
Points to Remember	1-33
Action Summary	1-34
Progress Check	1-35
LESSON TWO	
Activity Page	
Description of the Activity Page	2- 4
Using the Activity Page	2- 6
The Index	2- 9
The Active List	2-13
Checking the Amount of Disc Space (Storage) Left	2-22
Using a Write Protected Disc	2-23
Points to Remember	2-25
Action Summary	2-26
Progress Check	2-29
LESSON THREE	
Copy/Delete	
Copying Single Documents	3- 4
Deleting Single Documents	3- 5
Copying and Deleting More Than One Document	3- 7
Copying an Entire Disc	3- 9
Deleting the Entire Index	3-10
Copying Documents with the Same Titles	3-11
Points to Remember	3-13
Action Summary	3-14
Progress Check	3-17

Table of Contents (cont.)

LESSON FOUR	Pages
Print I	
Printing One Document	4- 4
Printing More Than One Document	4-11
Looking at the Print List	4-12
Deleting Documents from the Print List	4-12
Printing an Index	4-17
Description of Print Options	4-18
Points to Remember	4-20
Action Summary	4-21
Progress Check	4-23
LESSON FIVE	
Input I	
Typing Documents	5- 3
Using Some of the 860's Special Features	5- 8
Centering	5- 8
Underlining	5-14
Bolding	5-20
Adding to the End of a Document	5-25
Points to Remember	5-29
Action Summary	5-30
Progress Check	5-32
LESSON SIX	
Edit I	
Highlighting	6- 3
Adding and Deleting Underlining and Bolding	6-10
Making Revisions to Text	6-21
Using the Search Key	6-23
Inserting Text	6-25
Using the Replace Key	6-27
Making Other Revisions	6-32
Document Storing Decisions	6-37
Points to Remember	6-43
Action Summary	6-44
Progress Check	6-46

Table of Contents (cont.)

	Pages
LESSON SEVEN	
Format I	
Formatting	7- 3
Setting a Format	7- 4
The Recordable Format Page	7- 5
Using the Lower Tab Key	7-10
Using the Upper Tab Key	7-14
Using the Non-Recordable Format Page	7-20
Using More Than One Format	7-29
Using Reformat	7-35
Justifying the Margins	7-40
Points to Remember	7-46
Action Summary	7-47
Progress Check	7-50
LESSON EIGHT	
Utilities	
The Utility Selection Page	8- 3
The Backup Index Utility	8- 6
The Disc Duplicate Utility	8-14
The Initialize Utility	8-18
Initializing a New Disc	8-21
The Reconstruct and Recover Utilities	8-22
Points to Remember	8-24
Action Summary	8-25
Progress Check	8-29
LESSON NINE	
System Disc	
The System Disc	9- 2
The Master Format	9- 4
Points to Remember	9- 9

Xerox 860 IPS Operator Manual
Book One: Fundamentals

Lesson One – Introduction
Introduction to the Xerox 860 Information Processor

LESSON ONE

INTRODUCTION

Introduction to the Xerox 860 Information Processor

OBJECTIVES

After finishing this Lesson, you will be able to:

- use this manual and the Reference Manual
- describe the purpose of each piece of equipment in the basic 860 system
- create a new document on the 860 System

Materials Needed

For this lesson you will need:

- System Disc
- Student Disc
- Diagnostic Disc
- Reference Manual

TRAINING MATERIALS: What You Will Need

This section describes the training materials that you will need in order to learn how to use the 860 system.

The Operator Manuals

The first two manuals that you will use are:

Book One: FUNDAMENTALS

Book Two: WORD PROCESSING

The manuals are self-paced. That means you'll learn to operate the 860 system at your own pace--stopping to review explanations and practicing exercises as you feel the need. The exercises take you step by step through procedures you'll be using every day on the job. It's important to take the time you need to feel comfortable with the new knowledge and skills.

- Reread explanations if they're not clear the first time.
- Repeat exercises whenever you want to.
- Look for information in your Reference Manual.
- Talk to your Training Administrator* or call the Market Support Specialist at your local Xerox office.

After training, if you have problems on the job, Xerox provides information through the Customer Service Center. The Problem Solving section of your Reference Manual explains when to call the Customer Support Center and when to call your local Xerox office. The phone numbers for the Customer Support Center are:

Within the continental United States: 1-800-527-0212
In the State of Hawaii: 1-800-527-5890
In the State of Texas: 1-800-442-5751
In the City of Dallas, Texas: 233-2468

* Your Training Administrator is your supervisor or the person in charge of your training.

There are also many "helps" in each lesson:

- The Steps that you will go through to complete a training exercise are broken into actions that you take. Each action begins with a boldface word, such as **TOUCH** in the example below.

Step 1	TOUCH	the PAGE key.
	TYPE	the word Title
	TOUCH	the ACCPT key.

- Material that you will type is shown in boldface (like the word **Title** above) or shown in a box.
- The Objectives for each lesson are listed on the first page of the lesson, along with the materials that you will use in the lesson.
- The Practice Exercises will help you practice the skills that you learn in a lesson.
- Near the end of each lesson are Points to Remember that list important ideas you learned in the lesson.
- The Action Summary lists the skills you have learned in the lesson. You may want to make a copy of these pages to keep at your desk for a quick reference.
- The Progress Check will help you recall the important ideas and skills that you learn in the lesson. (The answers are provided on the next page.)

The Reference Manual

The Operator Manuals are accompanied by a Reference Manual. This is an additional source of information about the 860 Information Processing System.

In your Reference Manual you'll find instructions on how to change print wheels, install new ribbons, even how to run diagnostics to check out your system.

There's also a section on the messages you'll see on the screen. Should the 860 display a message that's new to you, you can quickly look it up in the Reference Manual. To become familiar with the Reference Manual, look up the message "COVER OPEN" in the **Messages & Symbols** section now. Then return to this page and continue.

There is another section of the Reference Manual that you will find very helpful after you have finished Book One. It's called the "**How To**" Glossary and lists (in a short form) all of the steps that are used to complete different tasks. For example, how to type a document or how to print a document.

Before You Begin

If at any time information is not clear to you--STOP. First, reread the explanation and try the procedure again. Refer to your Reference Manual for assistance. Finally, if you can't find the answer or work out the problem, talk to your Training Administrator or call the Xerox Market Support Specialist.

The Discs

The 860 uses discs to record typed information. Illustration I-1 below shows a disc and a disc envelope. When you're not using a disc, keep it in its envelope.

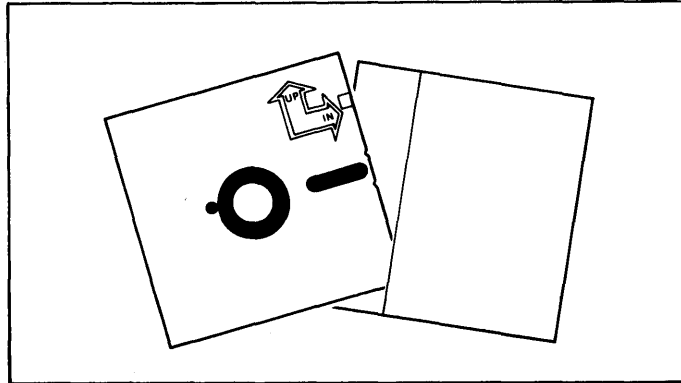

*Disc and Disc Envelope
Illustration I-1*

In this course, you'll use five different discs.

The **System Disc** is identified with a label that says: System Disc. This disc contains the operating instructions for the 860. These instructions tell the 860 how to respond to your keystrokes. A System Disc should have been made for your 860 when it was installed.

The **Student Disc** is a blank disc that you will use to type your own documents.

The **Training Disc** is identified with a label that says: Training Disc. It contains specially prepared documents for use in the training exercises.

The **Diagnostic Disc** is marked with the letter **D**. This disc is used to check the 860 to be sure it is in proper working order.

The **Master Disc** is identified with a label that says: Master Disc. It is a special disc is used to make a System Disc for your 860 System.

CHECK TO MAKE SURE YOU HAVE ALL FIVE DISCS. The Student, Training, Master and Diagnostic Discs should be inside Book Two and the Reference Manual. If you do not have a System Disc, you will be told to make one on page 1-13. If you don't have one of the other discs, talk to your Training Administrator or call the the Market Support Specialist at your local Xerox office.

The Equipment

The basic 860 Information Processing System is made up of a screen, a keyboard, a controller, and a printer.

The **screen** (see Illustration I-3 below) shows you all the information about the documents that you will be working with. It resembles a piece of paper and lets you see exactly what you're doing.

The Screen
Illustration I-3

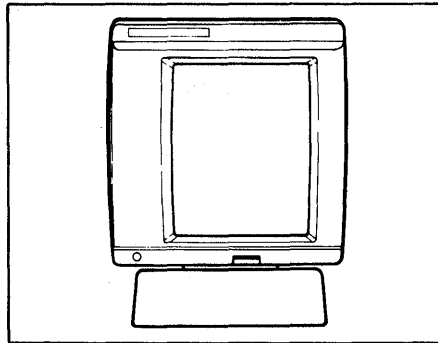

The **keyboard** (see illustration I-4 below) is very similar to a regular typewriter, but it has additional keys on the right and left of the typewriter keys. Some keyboards have a special device (called a "CAT") that helps you locate a specific position on the screen. The keys and the CAT will assist you in getting your work done quickly and easily.

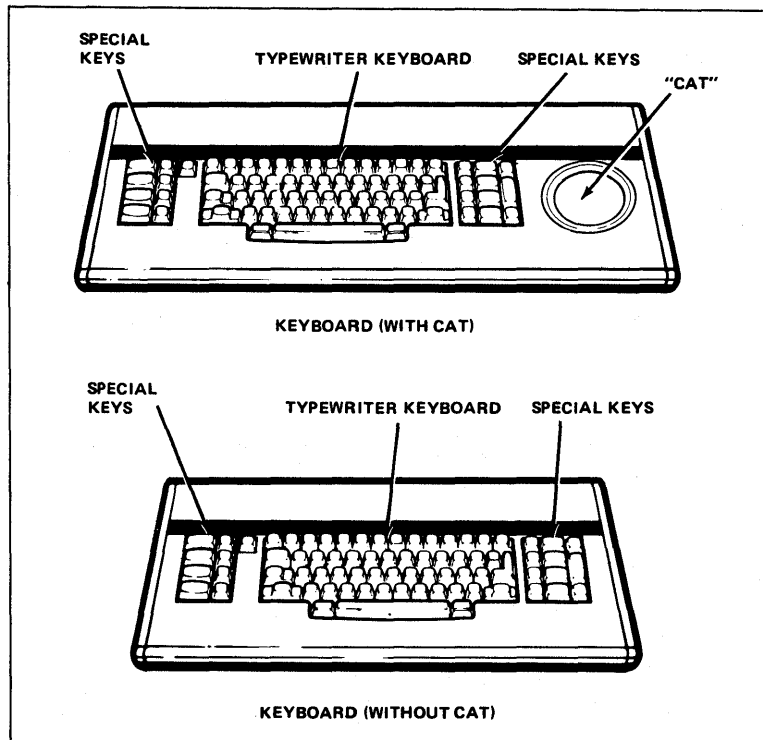

Keyboards Used with the 860 System
Illustration I-4

The **controller** contains the electronics that operate the system. Built into the controller are two stations for discs (see Illustration I-5 below).

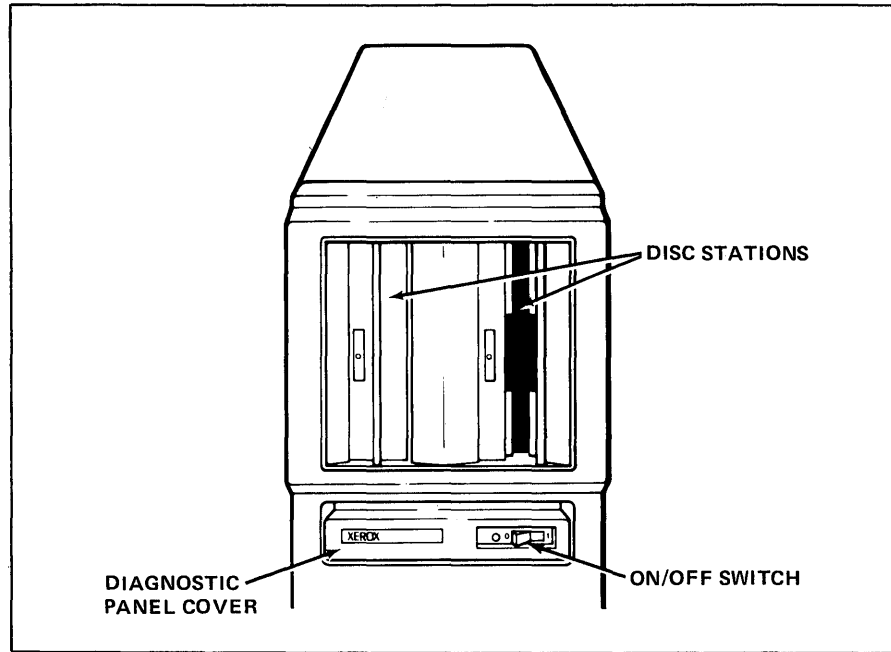

*Disc Stations in the Controller
Illustration I-5*

Everything you type on the 860 is stored on disc so you can revise or print the document at a later date.

There is also a diagnostic panel located near the on/off switch (see Illustration I-6 below).

Look at your controller again and find the cover over the on/off switch. The diagnostic panel is under the cover. The cover flips down. You'll use this panel to tell the system to run a self test.

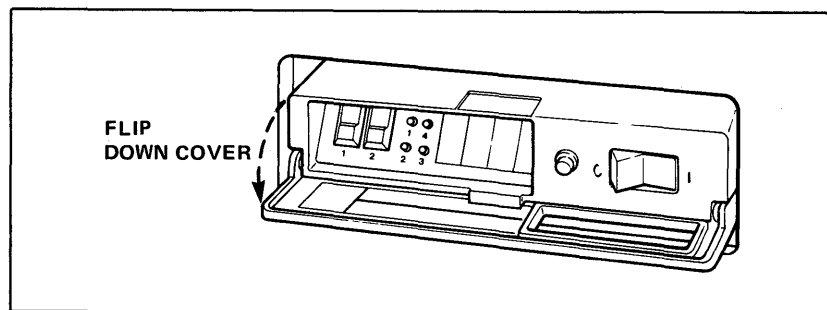

*The Diagnostic Panel
Illustration I-6*

Lesson One--INTRODUCTION

The **printer** is part of the 860 system. There are several different kinds of printers such as:

- the standard printer
- the PI printer
- a wide bed printer

The training assumes you will be using the standard printer (shown in Illustration I-7 below). The Reference Manual contains detailed information about all printers. When you need to know anything about your printer (such as how to change the ribbon), look in the Reference Manual.

Printers can also have accessories:

- an Automatic Paper Feeder (APF)
- a Shared Printer Interface (SPI)

The Automatic Paper Feeder will automatically feed paper into the printer. If you don't have one of these, you will have to insert the paper yourself.

The Shared Printer Interface is a special device that allows up to three systems to use the same printer. If you have a Shared Printer Interface, look in the **Discs and Peripherals** section of the Reference Manual to learn how to use it.

Look up "PRINTERS" now in the **Discs and Peripherals** section of your Reference Manual to become familiar with this section. Then return to this page and continue with the lesson.

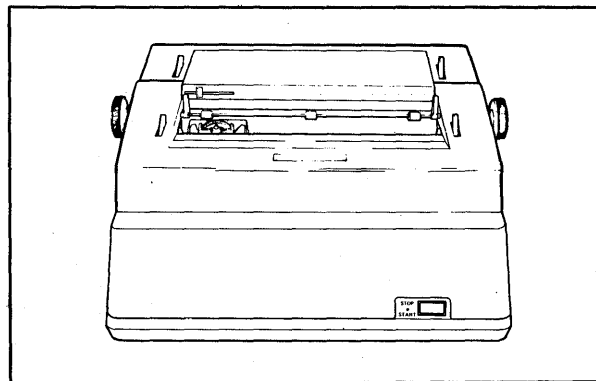

*A Standard Printer
Illustration I-7*

STARTING TO USE THE SYSTEM

Turning On the 860 System

The ON/OFF switch is located on the 860's controller. The ON/OFF switch uses international symbols: "1" for on and "0" for off.

Step 1 **TURN ON** your 860 by pushing the ON/OFF switch on the controller (see Illustration I-8 below).

Result The 860 automatically runs a 10-second diagnostic test. After the test, the screen will display the word XEROX as shown in Illustration I-9 on Page 1-10.

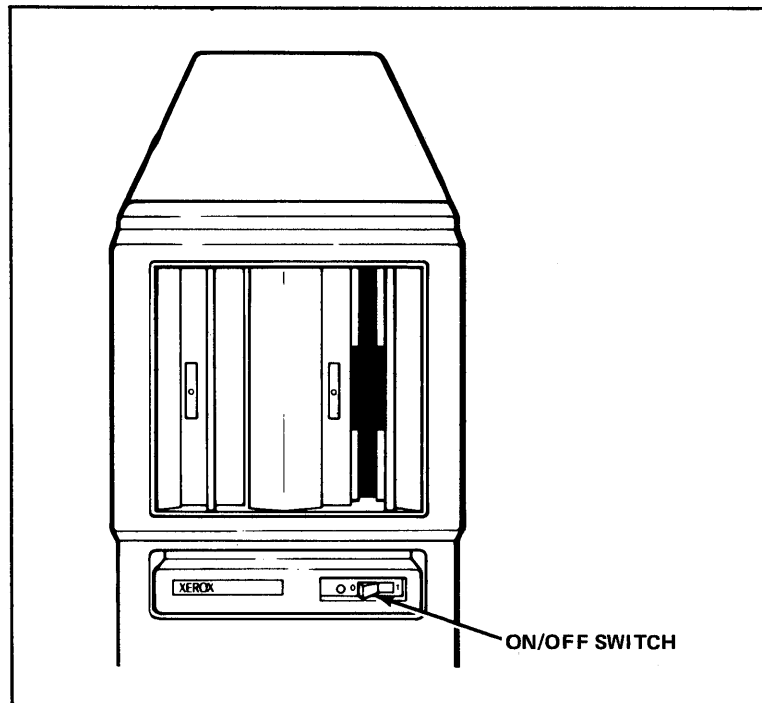

*The ON/OFF Switch on the Controller
Illustration I-8*

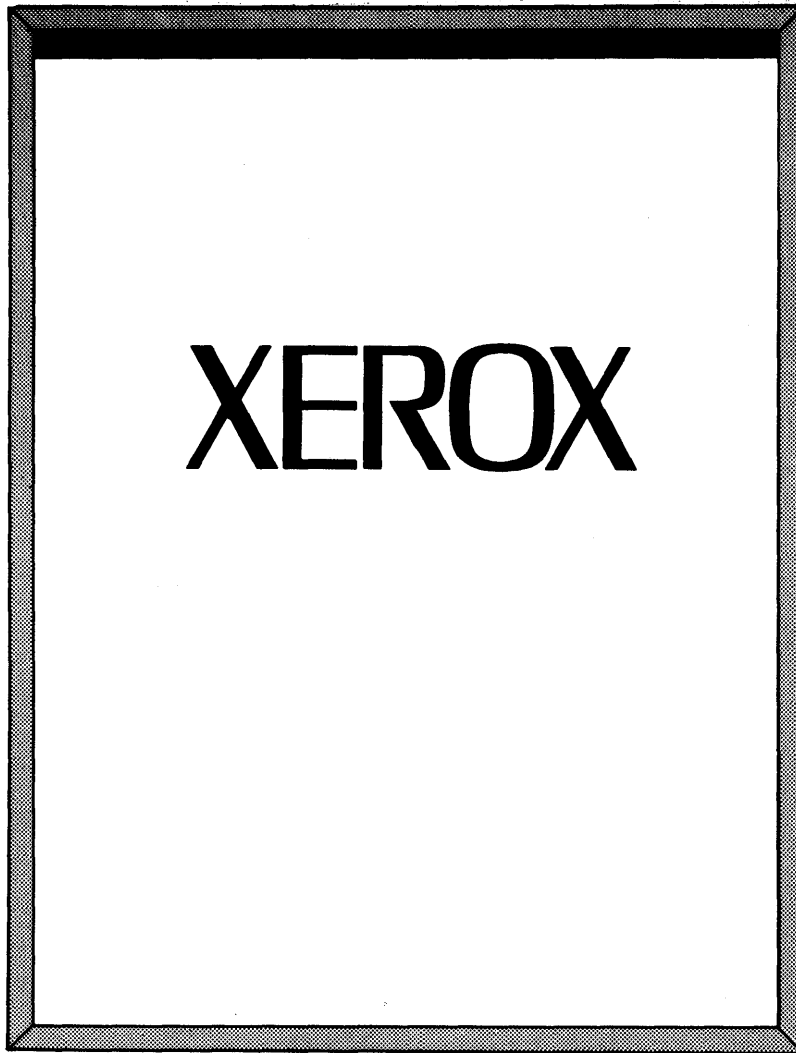

*The System Disc Page
Illustration F-13*

If the screen doesn't come on, check to be sure the 860 is plugged into a power outlet that has power. If the outlet is not the problem, ask your Administrator for assistance or call the Xerox office for service.

Once you have turned on the 860, you can leave it on for the rest of the working day.

THE SCREEN AND ITS ADJUSTMENT CONTROLS

The screen resembles a piece of paper and lets you see what you're typing. The screen can display a full line of 102 characters across and 66 lines of text down the page.

For glare-free viewing, the screen can be tilted by lifting the black lever centered directly below the screen. The brightness of the screen is increased or decreased with the black knob at the lower left of the screen (see Illustration I-10 below).

Adjusting the Screen

- Step 2** **ADJUST** the screen to a comfortable angle by lifting the tilt lever, moving the screen (up or down), then releasing the lever.
- ADJUST** the brightness of the screen by turning the brightness control knob located at the lower left of the screen panel.

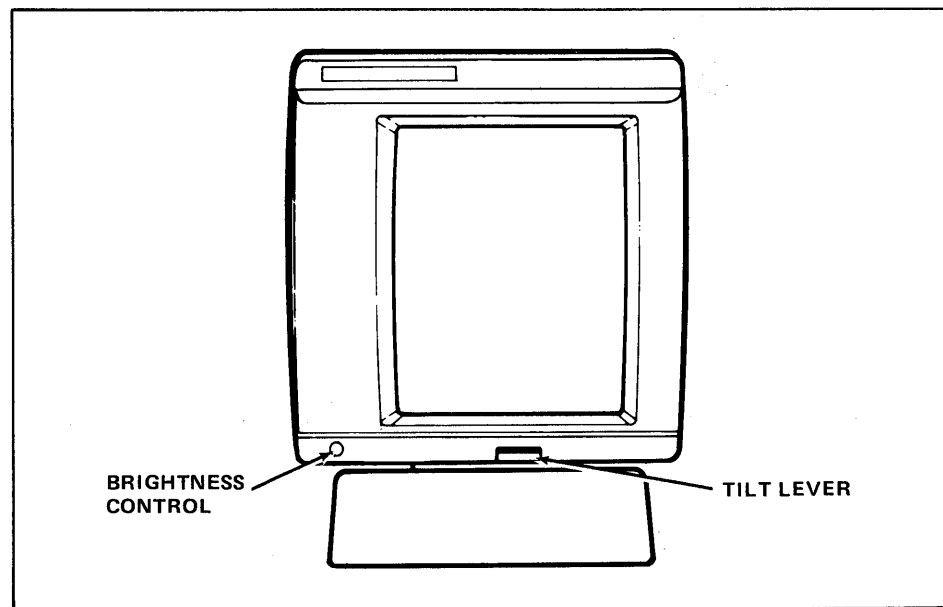

*The Screen and Its Adjustment Controls
Illustration I-10*

THE CONTROLLER

The controller has two stations for discs (see Illustration I-11 below). Everything you type on the 860 is stored on disc so you can revise or print the document at a later date.

On the disc station door is an oblong button with a red light. It is used to open the door.

Opening and Closing the Disc Station Doors

- Step 3** **PUSH** the oblong button with the red light.
Result If the door was closed, it should be open now.
- Step 4** **CLOSE** the door by pulling it to the left until it latches.
- Step 5** **PRACTICE** opening and closing the door once or twice, until you feel comfortable doing it.

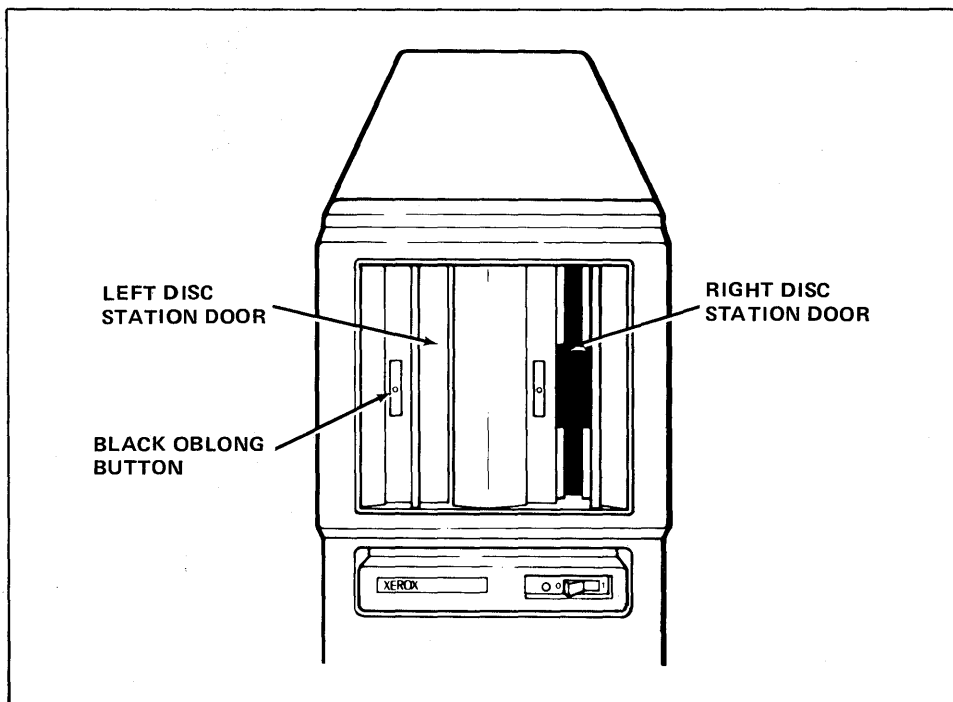

*Disc Station Doors
Illustration I-11*

THE SYSTEM DISC

After you turn on your 860, you need to put the operating instructions into the 860's memory. To do this, you insert a System Disc in the controller. The operating instructions on the System Disc tell the 860 how to respond to your keystrokes and are referred to as "software." The word software means operating instructions that can be transferred from a disc into the system's memory.

You may wonder why the 860 doesn't keep its operating instructions in memory all the time. It has a limited amount of room in its memory. By keeping the operating instructions on disc, the 860 can be more flexible. It has several sets of operating instructions, and offers a variety of features for different types of tasks.

Look at the picture below. Each disc has "Up and In" arrows to use as guides when inserting a disc.

Note: If you do not have a System Disc, turn to page 4-28 in the "**How to**" **Glossary** of your Reference manual and follow the instructions to make a System Disc.

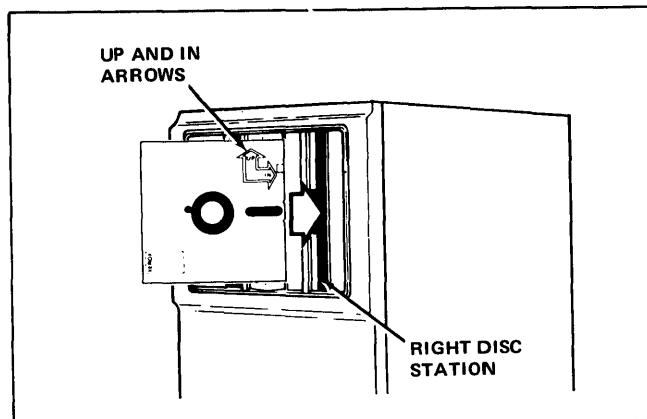

*Inserting the System Disc into the Right Disc Station
Illustration I-12*

Inserting the System Disc

- Step 6** **PUSH** the oblong button to open the right disc station door.
- INSERT** your System Disc as far as it will go into the right disc station. (Actually, you could use either disc station at this point. However, for these first few lessons, we will use the right station.)
- CLOSE** the door. (Pull it to the left until it latches shut.) Turn to the next page for the result.

Lesson One--INTRODUCTION

Result In a few seconds this message will appear at the top of the screen:

LOADING -- PLEASE WAIT

This means that the disc is operating correctly. After about 20 seconds, the screen will show the System Disc Page and will display this message:

ENTER DATE

Note: If, after 20 seconds, the System Disc Page doesn't display, there's been an error. First, check to be sure the System Disc was inserted correctly (hold the disc so the arrows point up in the air and in toward the controller). Reinsert the disc and press Restart (button #1) on the diagnostic panel (shown in Illustration I-24 on Page 1 - 29).

THE SYSTEM DISC PAGE

You will use the System Disc Page to tell the 860 the current date and which set of operating instructions (software) you want to use.

Look at Illustration I-13, below. Reading down the System Disc Page you'll find:

- the **second** line tells you that the right disc station has the System Disc; and that the left disc station is NOT READY (empty)
- the **third** line shows where today's date will be entered
- the **fourth** line lists the available software options
- the bottom half of the page contains the configuration of your 860

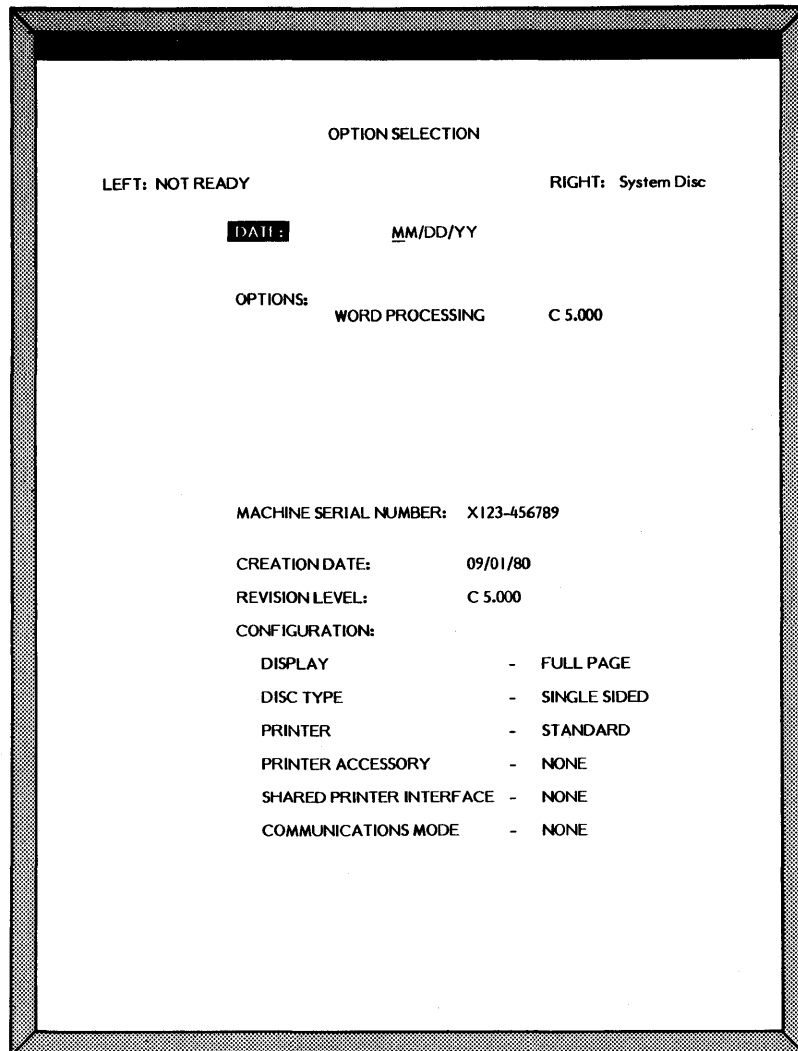

The System Disc Page
Illustration I-13

Lesson One--INTRODUCTION

Step 7 LOOK at the very top of the screen. The message ENTER DATE indicates that the 860 is waiting for you to enter the date.

On the third line the word DATE is highlighted. (The term "highlighting" means displaying white letters on a black background.) The highlighting shows that the numbers you type will be entered after the word DATE.

Using the System Disc Page

On the System Disc Page, you will enter the date and then select the Word Processing software.

When you enter the date, you'll use two-digit numbers for the month, day, and year. For example, the date April 1, 1990 would be written like this: 04/01/90.

All you will need to do is to type in the numbers (the 860 automatically puts in the slashes). So, for the date, April 1, 1990, you type:

040190

The 860 will place slashes between the two-digit numbers.

If you make a mistake while typing the date, you can use the BACKSPACE key (←) to erase the error (see Illustration I-14 below). Each time you touch the backspace key, the 860 erases the character that you just typed. After using the BACKSPACE key to erase the error, you can then type the correct number(s).

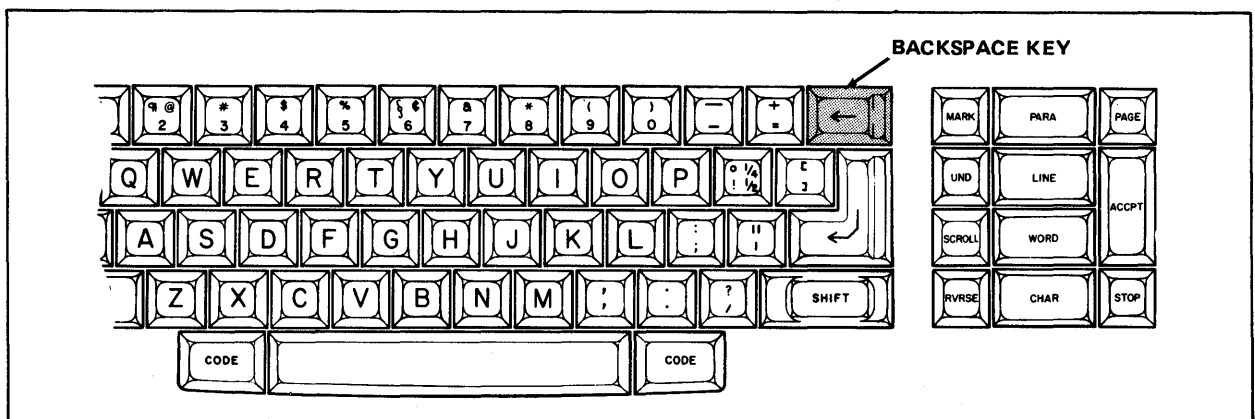

The BACKSPACE Key
Illustration I-14

Typing In the Date

Step 8 **TYPE** the numbers for today's date. Remember, you don't need to type the slash between the numbers--the 860 will automatically put in the slashes.

Result The numbers you typed are entered on the DATE line.

LOOK at the DATE line on your screen to see the date you just typed. If the date is not on the line, see the note below.

Note: If the SHIFT LOCK key was down when you typed the date, the 860 could not recognize the number you typed, so no date will appear on the DATE line. Release the SHIFT LOCK key and type the date again.

Selecting the WORD PROCESSING Option

Now you are ready to move the highlighting to the WORD PROCESSING option and tell the 860 this is the option you want. To do this you will use the LINE and ACCPT keys shown in Illustration I-15 below.

Step 9 **TOUCH** the LINE key.

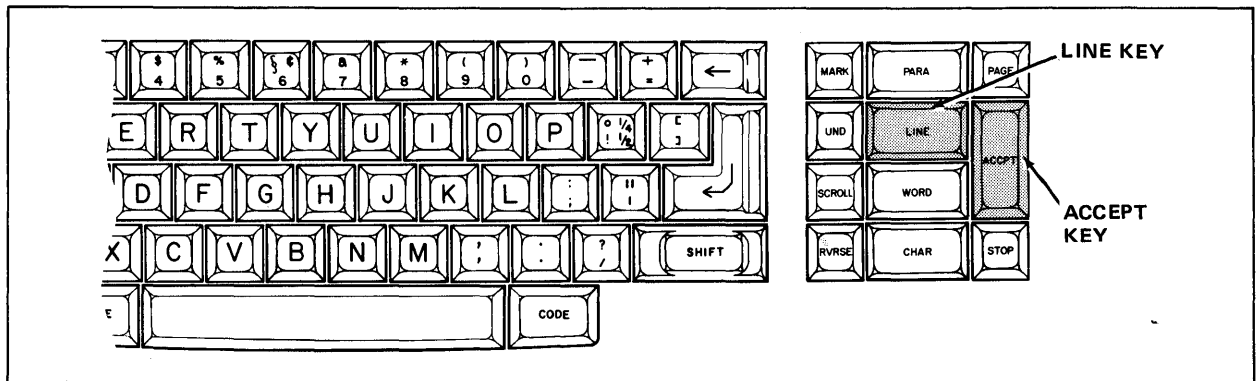

The LINE Key and ACCPT (Accept) Key
Illustration I-15

LOOK at the screen.

Result The highlighting moves to the words, WORD PROCESSING. The words at the top of the screen now read

SELECT OPTION

This message means that you're ready to select the software option. (Some System Discs may have several options to select from.) For the exercises in Books One & Two, you'll use the Word Processing software option.

Step 10 TOUCH the ACCPT key (shown in Illustration I-15 on Page 1-17) to tell the 860 that you want to use the Word Processing software.

Result The 860 displays this message at the top of the screen:

LOADING -- PLEASE WAIT

This means that the 860 is loading the Word Processing software from the System Disc (putting the operating instructions into the 860's memory).

WAIT for the software to load. It should take about a minute.

When the software has been loaded, the screen will display a new page, the Activity Page. (See Illustration I-16 on the next page). When you see this page, you know that you can start to work on the 860.

LOOK at the Activity Page on your screen.

1	2	3	4	5	6	7	8	9	0
	DISPLAY INDEX	DISPLAY PRINT LIST	DISPLAY COMM LIST			PRINT	PRINT INDEX	COMM	GO TO SYSTEM DISC
LEFT:			PRINTER: READY COMM:				RIGHT:		
ACTIVE LIST			WORD PROCESSING						
<u>TITLE</u>		<u>TYPE</u>	<u>DISC</u>		<u>ACTIVE PAGE</u>	<u>USAGE</u>		<u>SECTORS</u>	
INDEX: NOT READY			STORAGE LEFT: 0				MARKED DOCUMENTS: 0		
<u>ENTRY</u>	<u>TITLE</u>	<u>TYPE</u>	<u>CREATED</u>	<u>REVISED</u>	<u>PAGES</u>	<u>SECTORS</u>			

The Activity Page
Illustration I-16

**REVIEW OF
STARTING TO USE THE SYSTEM**

This page is a review of the procedures you've learned in this lesson. Read through the procedures to make sure you understand them, then go on with the lesson.

To turn the 860 System on:

- PUSH** the ON/OFF switch located on the front of the controller.
- WAIT** until the 860 runs a short diagnostic test. (The word "XEROX" will appear on the screen when it is ready to continue.)

To load the "Word Processing" option into the 860 system:

- OPEN** the disc station door. (Push the black oblong button on the disc station door.)
- INSERT** the System Disc (into either disc station).
- CLOSE** the disc station door.
- WAIT** until the Command Line displays: ENTER DATE.
- TYPE** the current date.
- TOUCH** the LINE key.
- TOUCH** the ACCPT key.
- WAIT** until the Activity Page is displayed.

CREATING A NEW DOCUMENT

In this exercise, you'll learn how to type a document on the 860. All documents you type on the 860 are recorded and stored on a disc. The 860 automatically keeps track of where your documents are stored on the disc.

The Student Disc

You will use the blank Student Disc to type your first document. Xerox discs come with a piece of tape along the edge near the "Up and In" arrows. This tape is called the Write Protect Tape (see Illustration I-17 below). Be sure the tape is **on** the Student Disc before you record on it. When you take the tape **off** a disc, the disc cannot be recorded on or erased.

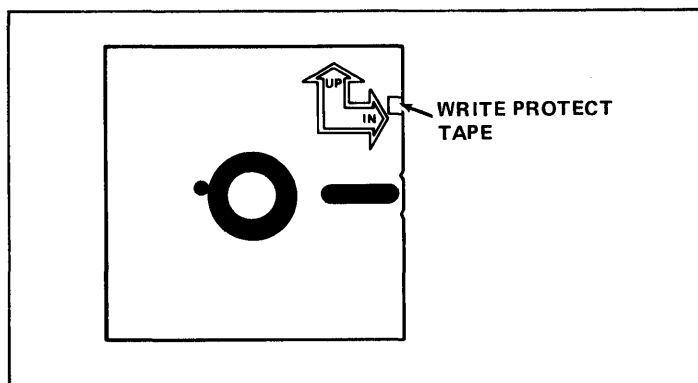

Location of the Write Protect Tape
Illustration I-17

- Step 1**
- INSERT** your Student Disc as far as it will go into the **left** disc station. (Use the arrows on the disc as guides.)
- CLOSE** the door.
- Result** The system checks the disc to be sure it's an 860 disc.
- LOOK** at the line under the boxes at the top of the screen. **LEFT: Student Disc** is highlighted. "Student Disc" is the name of the disc you just inserted in the left disc station.

Note: If your screen shows **LEFT: NOT READY**, you may have put the disc in wrong. Remove the disc, then insert it again using the arrows on the disc as guides. If you use a disc that is not an 860 disc, the word **UNKNOWN** will appear next to **LEFT**. Should this happen, check to be sure you inserted the disc marked Student Disc. Try reinserting the disc. If it still says **UNKNOWN**, talk to your Administrator or call the Market Support Specialist at your Xerox office.

Beginning a New Document

Any document you type on the 860 must be given a title. Your document titles can contain up to 20 characters. The 860 automatically files the documents by title so that you can easily bring a document back to the screen for changes. No two documents can have exactly the same title.

You will use the word "NAME" for the title of your new document. But there are some things that you should look at as you type. Follow the instructions below to title your document. Remember, if you make a mistake, use BACKSPACE key to erase it.

Step 2 **TYPE** a capital letter **N**.

LOOK at the top of your screen.

Result As soon as you type the first letter of the name of your new document, the top of the screen will display this message:

```
ENTER TITLE                    "N"
```

The letter "N" has appeared in quotation marks after the words ENTER TITLE. As you continue to type, the rest of the letters will appear between the quotation marks.

FINISH typing the title **NAME**.

Result When you finish, the top of the screen will display this message:

```
ENTER TITLE                    "NAME"
```

The black line at the top of the screen is called the **Command Line**. It will give you messages to help you as you use the 860 System. Some of the messages will be questions. You'll use the ACCPT key to answer "yes" to the questions, and the STOP key (located below the ACCPT key) to answer "no."

Step 3 TOUCH the ACCPT key to tell the 860 you're finished typing the title.

Result The Command Line displays the words:

NEW DOCUMENT?

LOOK at your screen and check the message in the Command Line.

TOUCH the ACCPT key again to tell the 860 "Yes, this is a new document."

Result **NAME** is listed under the word TITLE in the ACTIVE LIST, as shown in Illustration I-18 below.

LOOK at your screen and find **NAME** in the ACTIVE LIST.

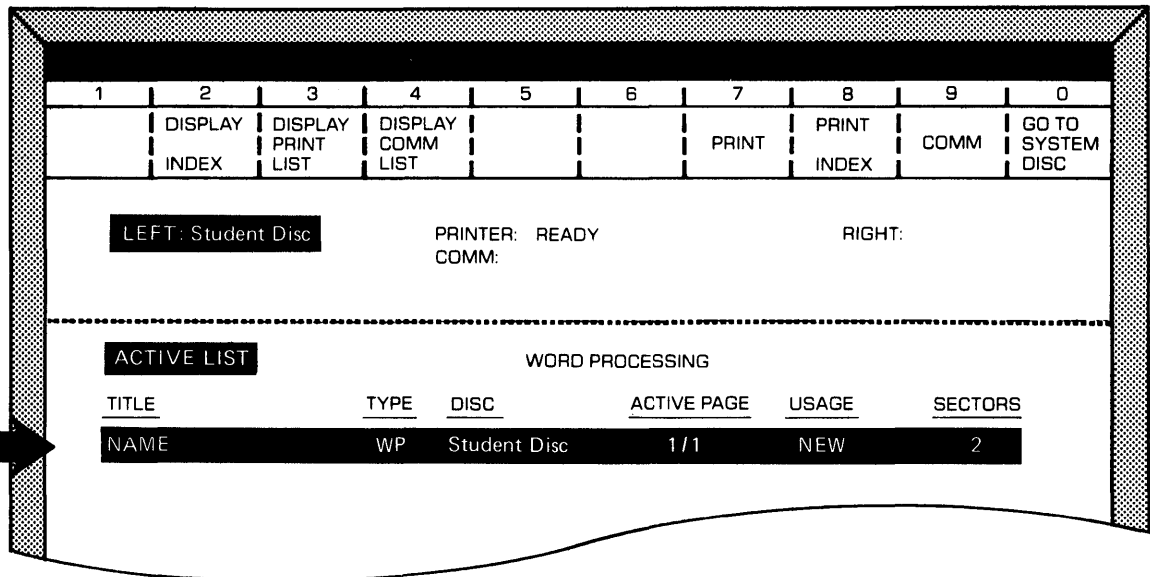

The Document **NAME** in the Active List
Illustration I-18

The ACTIVE LIST shows you the titles of documents you are typing, revising, or printing.

Step 4 TOUCH the ACCPT key once more to tell the 860 you want to begin working on this document.

Result A blank page for your typing comes up on the screen.

Working on the New Document

The Command Line displays the title and page number of the document you are working on. Next to the title and page number you see a line and character counter. Remember, the screen is just like a piece of typing paper. The line number tells you how far down on the paper the line will print and the character number tells you the position of the next typed character.

Below the Command Line, two small rectangular boxes are shown (see Illustration I-19 below); one resembles a domino and the other a solid box.

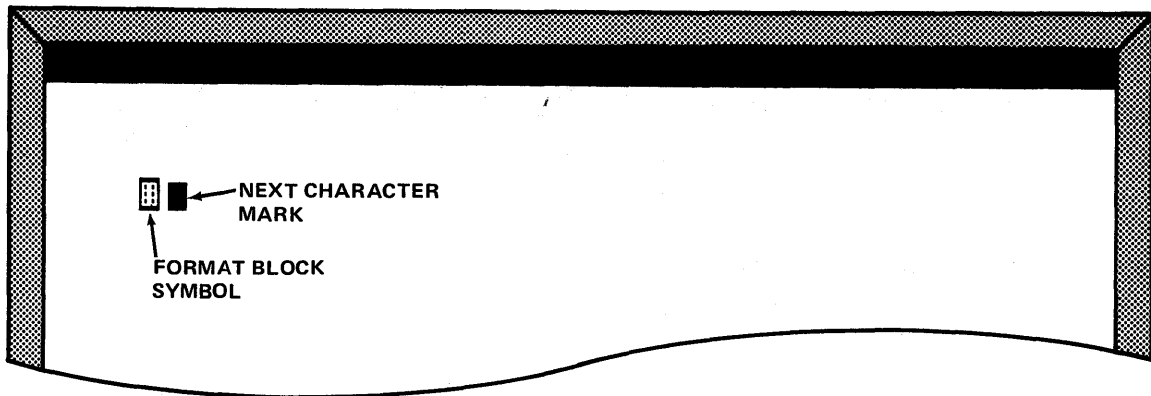

*The Format Block Symbol and Next Character Mark
Illustration I-19*

The first symbol (the domino) is called the Format Block symbol. Every document must have a Format Block as the first character on each page. Later, you will learn to use the Format Block to set the margins and the tabs. At this time, the 860 System automatically uses margins of 12 and 84 with no tabs set.

The second symbol (the solid box) is called the Next Character Mark. It indicates where the next character you type will go.

- Step 5** **TYPE** your first and last name (do not return the carrier).
- Result** The Next Character Mark moves across the page in front of your typing.
- LOOK** at the screen to see the Next Character Mark.
- TOUCH** the RETURN key (↵) after your last name (see Illustration I-20 below).

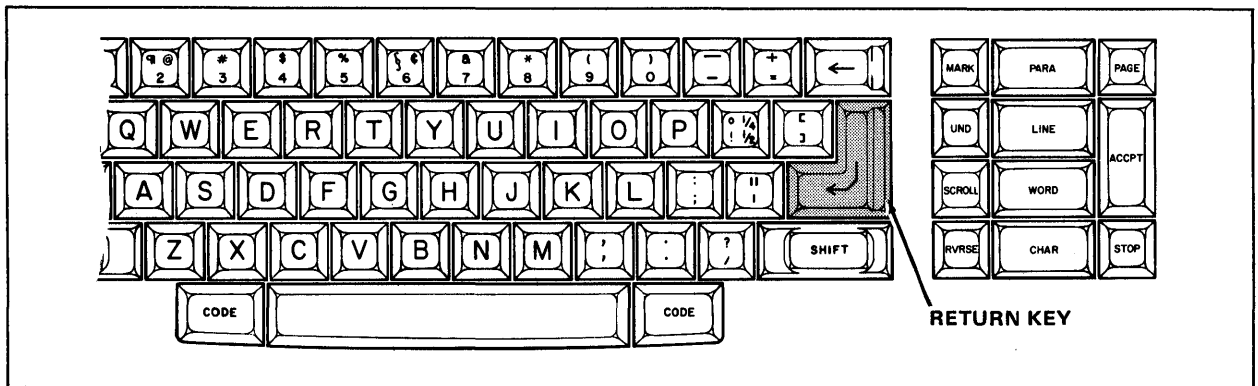

The RETURN Key (Carrier Return)
Illustration I-20

- Result** The Next Character Mark returns to the left margin and moves down the page one line. Also, the line you just typed is now shown in smaller characters.
- NOTICE** also that the Format Block (the domino symbol) disappeared as soon as you touched the RETURN key.

The 860 System displays special symbols only on the line that you are typing. Even though the Format Block has disappeared from the screen, it will be recorded with the document.

- Step 6** **TYPE** your address and the name of the company you work for, touching the RETURN key at the end of each line.

Storing a New Document

Now that you've finished typing your first document, you need to store it on your Student Disc. Until the document is stored, you have no permanent record of the document. To tell the 860 that you want to store a document, you use the STORE key (see Illustration I-21 below).

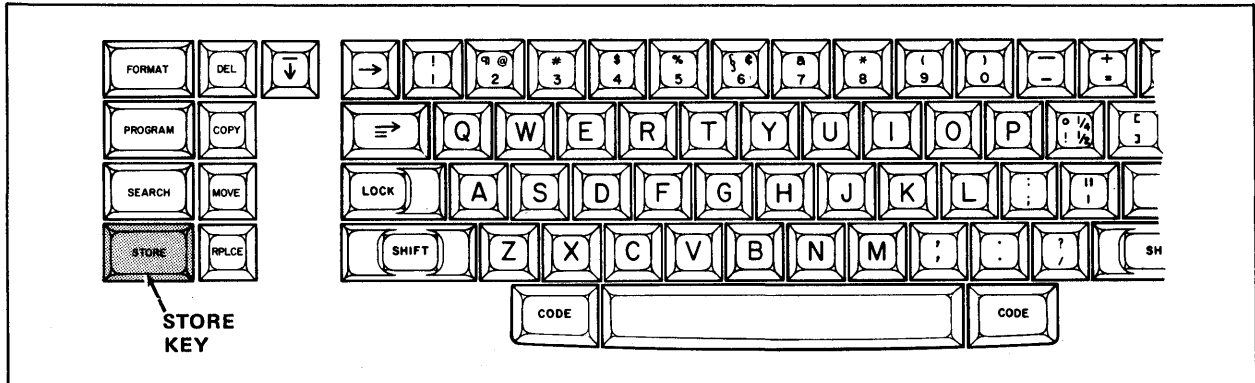

The STORE Key
Illustration I-21

Step 7 TOUCH the STORE key.

Result The document is removed from the screen. The Activity Page comes back to the screen and the Command Line displays the message:

STORE DOCUMENT?

CHECK the message in the Command Line of your screen.

TOUCH the ACCPT key to answer "yes" to the question.

Result The title NAME is listed in the INDEX, indicating your document is stored on the disc.

Remember, your new document is not stored automatically. You must touch the STORE key and the ACCPT key to tell the 860 to store it on the disc.

LOOK at your screen and locate the title **NAME** on the **INDEX** of the Student Disc (see Illustration I-22 below).

The 860 has automatically assigned a number to your document. Since it is the first document on the disc, it is entry number one (1). Notice that today's date has been entered under the heading **CREATED** to indicate that your document was typed (created) on this date.

<u>ENTRY</u>	<u>TITLE</u>	<u>TYPE</u>	<u>CREATED</u>	<u>REVISED</u>	<u>PAGES</u>	<u>SECTORS</u>
1	NAME	WP	MM/DD/YY	//	1	2

INDEX: Student Disc STORAGE LEFT: 0 MARKED DOCUMENTS: 0

END OF INDEX

The Document **NAME** Stored in the Index
Illustration I-22

**REVIEW OF
CREATING A NEW DOCUMENT**

This page is a review of the procedures you've learned in this lesson. Read through the procedures to make sure you understand them, then go on with the lesson.

Before you can create a new document, you must have a disc in the controller and the Activity Page displayed on the screen.

To give a new document a title:

- CHOOSE** an appropriate title (up to 20 characters).
- TYPE** the title.
- TOUCH** ACCPT three times. Once to say Yes to NEW DOCUMENT, once to put the title in the Active List and once more to bring a blank page to the screen.

To type the text of the document:

- USE** the keyboard.

To store a new document onto your disc:

- TOUCH** the STORE key to move document to the Active List.
- TOUCH** the ACCPT key to put the document on the disc and list the title in the Index.

USING THE DIAGNOSTIC PANEL AND DISC

Look at your controller and locate the cover over the on/off switch. The diagnostic panel is located under the cover (see Illustration I-24 below). The cover flips down. If your system is not working correctly, you can use this panel to tell the system to run a self test. Step-by-step instructions for running the test are given in your 860 Reference Manual.

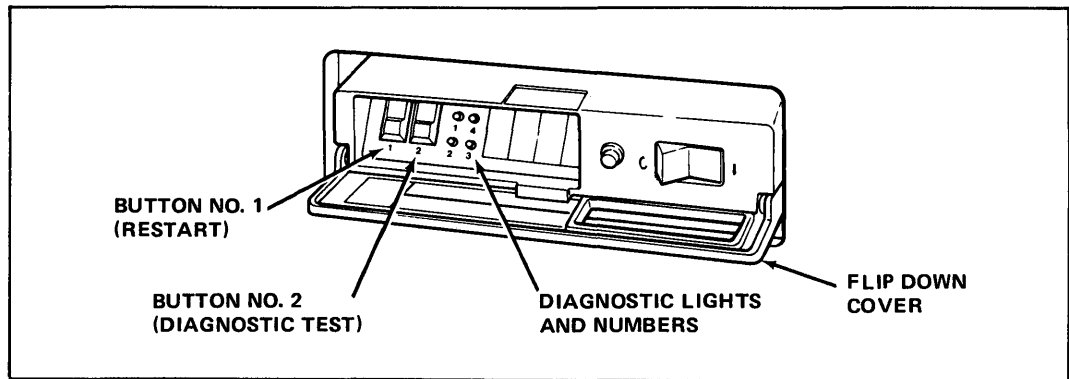

*The Diagnostic Panel
Illustration I-24*

Step 1 **LOOK** up Diagnostics in your Reference Manual in the "How To" Glossary.

FOLLOW the instructions to run the diagnostics on your system.

When the test is complete (it will take about 4 minutes), return to this page and go on with the lesson.

TURNING OFF THE 860

When you turn the 860 on, you can leave it on all day. Once the software is loaded, it will stay in the 860's memory and it will be ready to use any time you want to work on a document.

Before you turn off the 860 at the end of the day, remove your discs.

Step 1 REMOVE any discs from the 860's controller.

TURN OFF the 860 by pushing the ON/OFF switch on the controller.

Whenever you turn off your 860, you should remove your discs first. Discs should be put back in their protective envelopes and stored in an upright position.

Your discs will last a long time if you handle them carefully and store them properly.

- Never place the disc near magnets. This includes paper clip holders that have a magnetic cup.
- Don't touch the exposed surfaces of the disc. Skin oils and the residue from hand lotion can damage the magnetic coating.
- Never write on the disc. Always use an adhesive label and apply it to the black disc cover (see Illustration I-23 below) and be sure you don't cover any of the exposed magnetic surfaces!

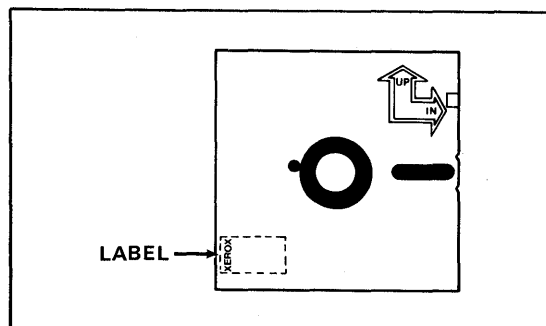

Placement of the Label on a Disc
Illustration I-23

Now that you know how to turn off the 860, use the steps below to turn it on again. Remember, you must use the System Disc to put software into the 860's memory when you turn it on.

- Step 1** **TURN ON** the 860 by pushing the ON/OFF switch on the controller.
- Step 2** **INSERT** the System Disc in the right disc station and close the door.
- WAIT** for the System Disc Page to come to the screen.
- Step 3** **ENTER** today's date. Remember, type two numbers for the month, two for the day, and two for the year.
- TOUCH** the LINE key to highlight WORD PROCESSING.
- TOUCH** the ACCPT key to tell the 860 you want this option.
- WAIT** for the 860 to load the software and display the Activity Page on the screen.

It is a good idea to leave the System Disc in the 860 after the software has been loaded. There may be times when the 860 will need to get additional information from the disc and it can do so automatically if the System Disc is in the controller.

Lesson One--INTRODUCTION

You have now completed Lesson One. On the next pages there are Points to Remember and an Action Summary for you to review.

There is also a Progress Check for you to complete. If you should answer any of the questions incorrectly, turn to the page indicated in the answer and review the information.

POINTS TO REMEMBER

- The 860 uses discs to record typed information. (Page 1-5)
- Once you turn on the 860, you should leave it on for the rest of the working day. (Page 1-30)
- The ACCPT key is used to begin actions or to answer "yes" to questions displayed in the Command Line. (Page 1-22)
- The STOP key is used to halt actions or to answer "no" to questions in the Command Line. (Page 1-22)
- Each disc has Up and In Arrows to use as guides when inserting the disc. (Page 1-13)
- The System Disc contains the operating instructions (software) for the 860. (Page 1-13)
- When you turn on the 860, you use the System Disc to put the operating instructions in memory. (Page 1-13)
- Once the operating instructions (software) are in the 860's memory, the 860 displays the Activity Page. (Page 1-18)
- All new documents must be given a title. The title can have up to 20 characters in it. (Page 1-22)
- To guide you, the 860 displays messages in the Command Line at the top of the screen. (Page 1-22)
- The Next Character Mark shows the position for the next typed character. (Page 1-24)
- When you turn off the 860, remove your discs first. It's very important to handle and store discs properly. Store discs in their protective envelopes. (Page 1-30)

ACTION SUMMARY

You may want to make a copy of this ACTION SUMMARY and keep it on your desk for quick reference.

Before you can use the 860, you must turn it on and load the software into its memory. You can then leave the 860 on all day.

To start to use the 860:

- Step 1 TURN ON** the 860 by pushing the ON/OFF button on the front of the Controller.
- Step 2 LOAD** the software, using the following steps:
- Insert the System Disc
 - Close the disc station door
 - Wait until the Command Line displays ENTER DATE
 - Type the current date
 - Touch the LINE key
 - Touch the ACCPT key

To create a new document:

- Step 1 BEGIN** by typing a title for the document, using the following steps:
- Type an appropriate title (up to 20 characters)
 - Touch ACCPT three times
- Step 2 TYPE** the text in the document.
- END** the document with a carrier return.
- Step 3 STORE** the document, using the following steps:
- Touch the STORE key
 - Touch the ACCPT key

To turn off the 860:

- Step 1 REMOVE** any discs from the disc stations.
- Step 2 PUSH** the ON/OFF switch on the front of the Controller.

PROGRESS CHECK

Answer each question by filling in the blank with the correct answer, then compare your answers with those on Page 37. You should write your answers on a separate sheet of paper to avoid marking up the manual.

1. The _____ Disc contains the 860's operating instructions or software.

2. The characters you type are shown on the _____.

3. The _____ on the disc show you which way to insert the disc in the controller.

4. When you see a message like STORE DOCUMENT?, you can touch the _____ key to answer "yes" to that message.

5. To remove a document from the screen and store it on the disc, touch the _____ key and then touch the _____ key.

6. If you get a message that's different from one shown in this book, you would look in the _____ manual to find out what the message means.

7. Look up **END OF RIBBON** in the Messages & Symbols section of the Reference Manual and read the Reason and Action.

The Command Line displays the message when

Lesson One--INTRODUCTION

(This page is intentionally left blank.)

ANSWERS TO PROGRESS CHECK

If you are uncertain or missed an answer, refer to the pages listed on this answer form to review the original material. When you feel comfortable with this material, return to this point in the lesson and continue.

1. The System Disc contains the 860's operating instructions or software. (Page 1-13)
2. The characters you type are shown on the SCREEN. (Page 1-24)
3. The arrows on the disc show you which way to insert the disc in the controller. (Page 1-13)
4. When you see a message like STORE DOCUMENT?, you can touch the ACCP key to answer "yes" to that message. (Page 1-22)
5. To remove a document from the screen and store it on the disc, touch the STORE key and then touch the ACCP key. (Page I-26)
6. If you get a message that's different from one shown in this book, you would look in the Reference manual to find out what the message means. (Page 1-4)
7. Look up **END OF RIBBON** in the Messages & Symbols section of the Reference Manual and read the Reason and Action.

The Command Line displays the message when the system
detects the end of the ribbon.

Lesson One--INTRODUCTION

(This page is intentionally left blank.)

Xerox 860 IPS Operator Manual
Book One: Fundamentals

Lesson Two – Activity Page
Learning to Use the Activity Page

LESSON TWO

ACTIVITY PAGE

Learning to Use the Activity Page

OBJECTIVES

After finishing this lesson you will be able to:

- name each section of the Activity Page
 - describe the purpose of each section of the Activity Page
 - use the Index and Active List sections of the Activity Page
 - move documents into the Active List
 - mark documents
 - delete documents from the Active List
 - check the amount of disc space available
-

Materials Needed

For this lesson you will need:

- System Disc
- Student Disc
- Training Disc
- Reference Manual

BEFORE YOU BEGIN

Check to be sure your 860 is set up as follows:

- System ON.
- ACTIVITY PAGE on screen.
- System Disc in the disc station.

If your 860 is set up correctly, the Activity Page will be displayed on your screen. It should look about like Illustration II-1 below.

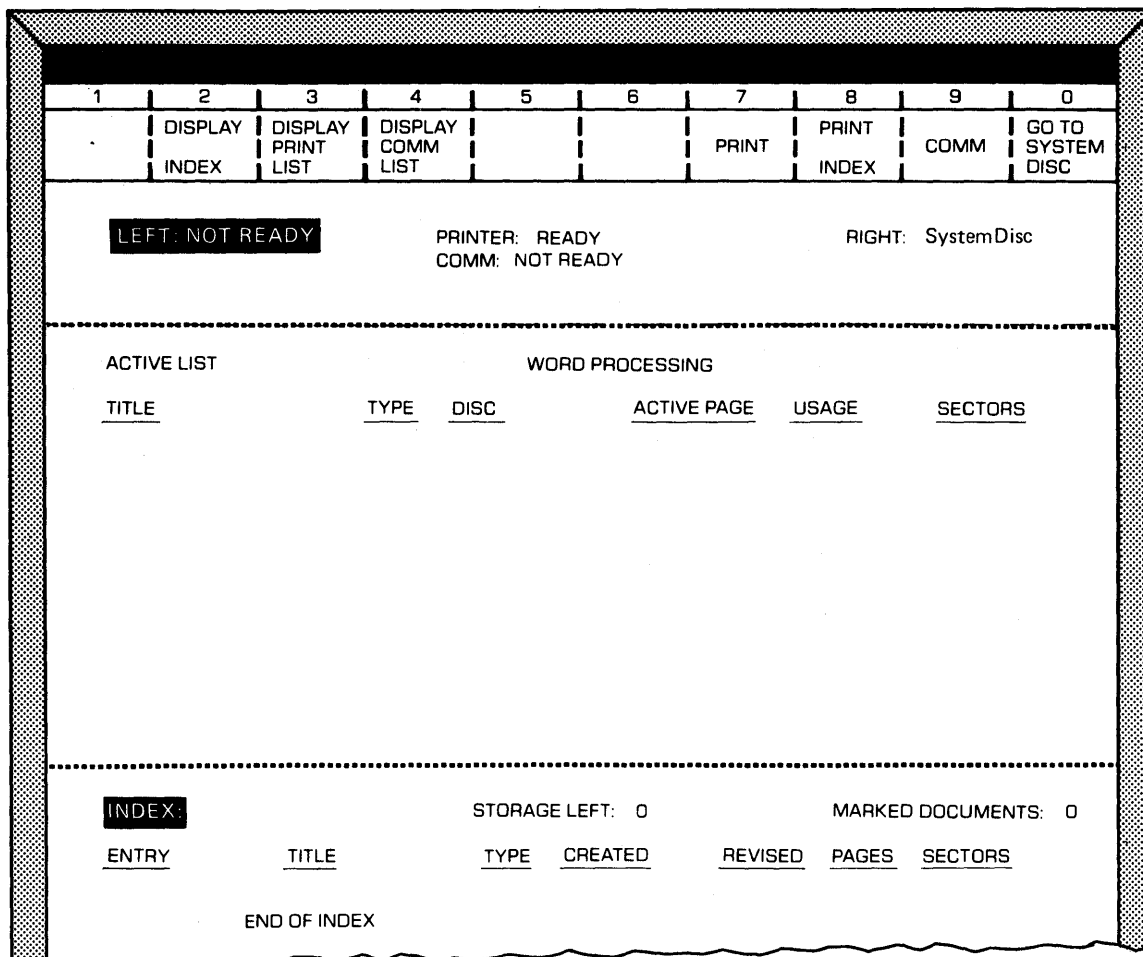

The Activity Page
Illustration II-1

If your 860 is turned off or displays XEROX on the screen, you should turn to page 1-31 in Lesson One and follow the instructions for loading the software. Then return to this lesson and continue.

DESCRIPTION OF THE ACTIVITY PAGE

The Activity Page is a "home base" to start from and return to when you're using the 860. Documents are started, printed, deleted and copied from this "home base."

The Activity Page lists every document stored on the disc under the heading INDEX. Think of your disc as a file cabinet. The INDEX is a listing of all the titles on the folders in the cabinet -- an index to the file cabinet contents.

When you insert a disc into the 860, it looks at the INDEX on the disc and displays all the titles for you. Each disc has its own INDEX. The 860 will automatically put your document titles into the INDEX when you store your documents. That's why you must store a document before taking out your disc or turning off the 860.

Look at the illustration of the Activity Page (Illustration II-2) on the next page.

It's divided into these sections:

COMMAND LINE	Displays messages and prompts
INSTRUCTION BLOCKS	Describe functions of keys on the Activity Page
STATUS LINE	Displays information on disc stations and the printer
ACTIVE LIST	Displays titles of working documents
INDEX	Displays titles of all stored documents

The next section will describe each of these and give instructions on how to use them.

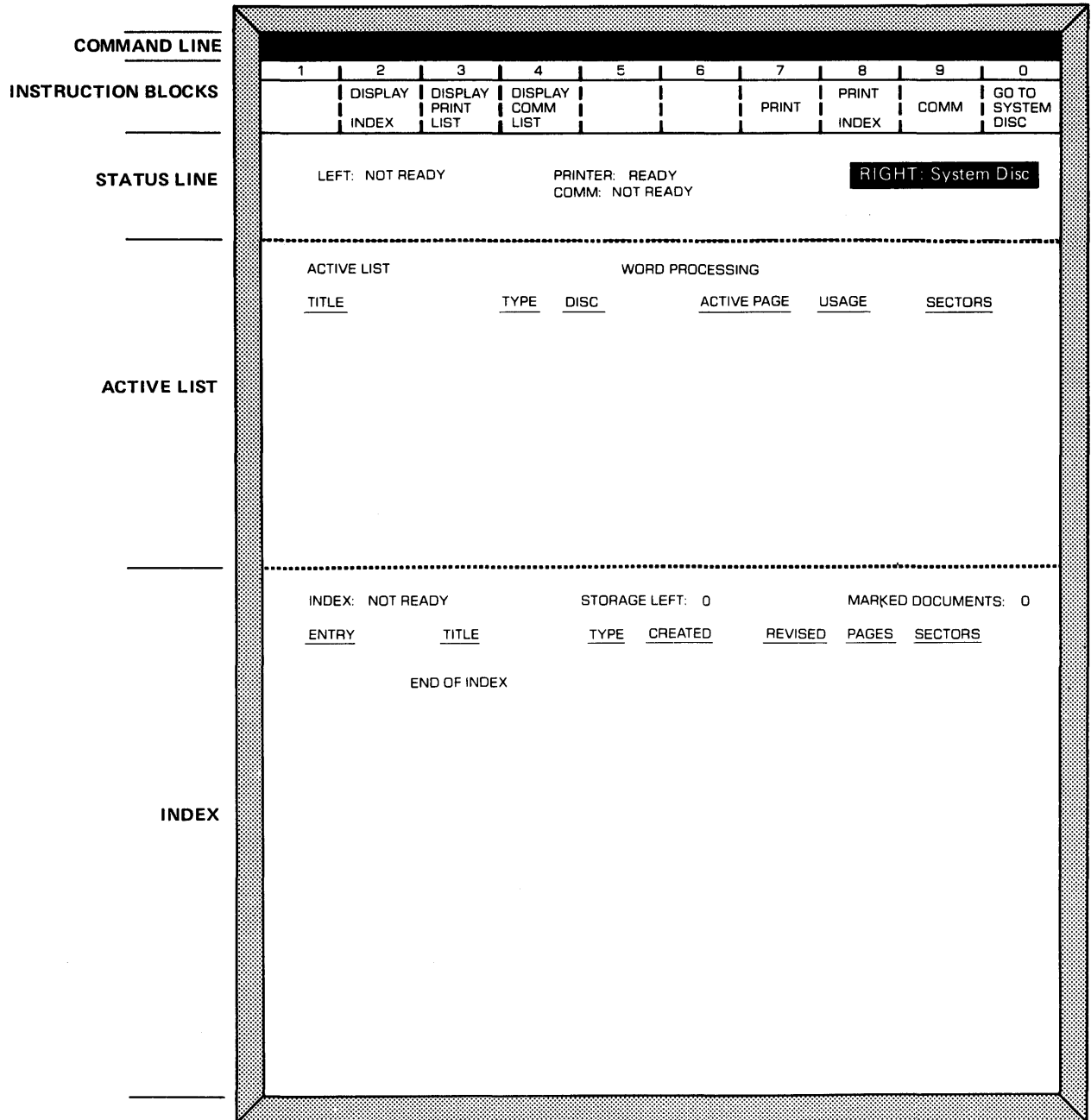

Names of Sections on the Activity Page
Illustration II-2

USING THE ACTIVITY PAGE

Now that you have seen the various sections of the Activity Page, you can practice using them.

The Command Line

The Command Line displays messages to guide you. You respond to the messages in the Command Line by touching keys on the keyboard.

The Instruction Blocks

The Instruction Blocks (see Illustration II-3 below) describe the functions of some of the numeric keys on the Activity Page. You'll be using the Instruction Blocks later in your training.

1	2	3	4	5	6	7	8	9	0
	DISPLAY	DISPLAY	DISPLAY			PRINT	PRINT	COMM	GO TO
	INDEX	PRINT	COMM				INDEX		SYSTEM
		LIST	LIST						DISC

*The Instruction Blocks
Illustration II-3*

The Status Line

The Status Line tells you what's happening with the disc stations and the printer (see Illustration II-4 below).

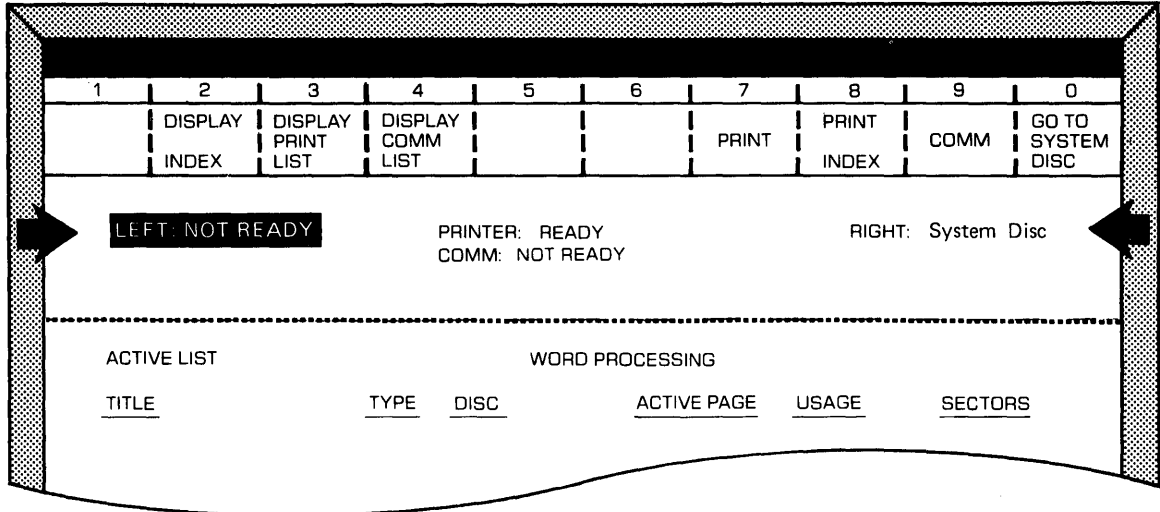

*Disc Station Messages
Illustration II-4*

On your 860, the System Disc is in the right Disc Station, so the Status Line indicates it as **RIGHT System Disc**. (If your System Disc has a different name, its name will appear after the word RIGHT.)

The Status Line can indicate these types of messages:

- LEFT: NOT READY** The message NOT READY indicates that there is no disc in the left station, or that the disc has been inserted improperly.
- RIGHT: "name"** Indicates the name of the disc in the right disc station.
- PRINTER READY** Indicates the printer is ready to print. Other printer messages might be: PRINTER BUSY or PRINTER NOT READY.

Selecting Disc Stations

For the rest of this lesson, you will need to use your Student Disc and Training Disc.

Step 1 REMOVE the System Disc. (Place it in its protective envelope.)

INSERT the Training Disc in the right disc station.

INSERT the Student Disc in the left disc station.

The PARA key (see Illustration II-5 below) is used to switch from one disc to the other. In the following steps, you'll switch to the disc in the right station and look at its INDEX.

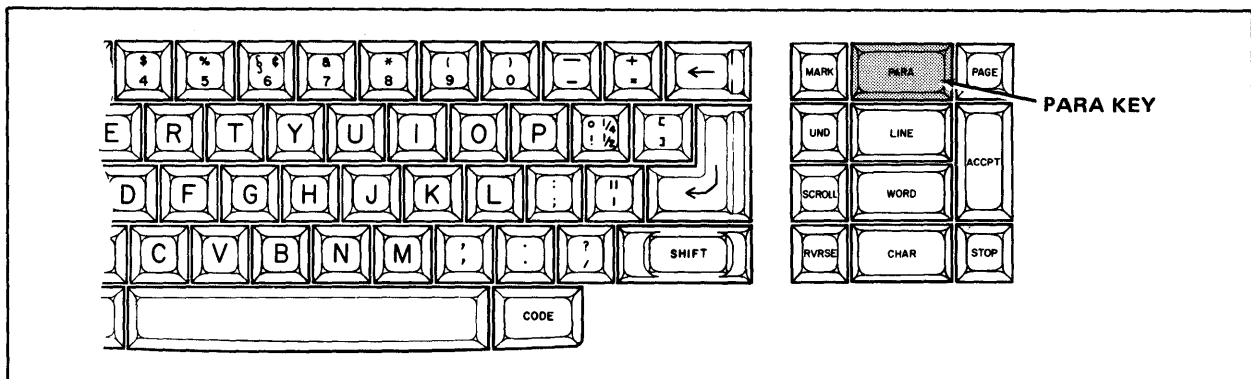

The PARA key
Illustration II-5

Step 2 TOUCH the PARA key.

Result The action switches from the left station to the right. Notice the highlighting moved to **RIGHT: TrainingDisc**.

LOOK at the INDEX. Notice that the heading now says **INDEX: TrainingDisc**. The titles listed on the INDEX are the documents recorded on the Training Disc.

TOUCH PARA once or twice to see the action switch back and forth between the two discs. Watch the list of documents change as you switch the action.

MOVE the highlighting to the **right** station (touch PARA) before you go on.

THE INDEX

The INDEX lists the titles of all documents stored on a disc.

Look at your screen again, and locate the headings: ACTIVE LIST and INDEX. Remember when you typed your first document, the title was in the ACTIVE LIST while you were working. When you stored the document, the title went into the INDEX.

Selecting the ACTIVE LIST or INDEX

You can move the highlighting between the ACTIVE LIST and the INDEX by touching the PAGE key (see Illustration II-6 below).

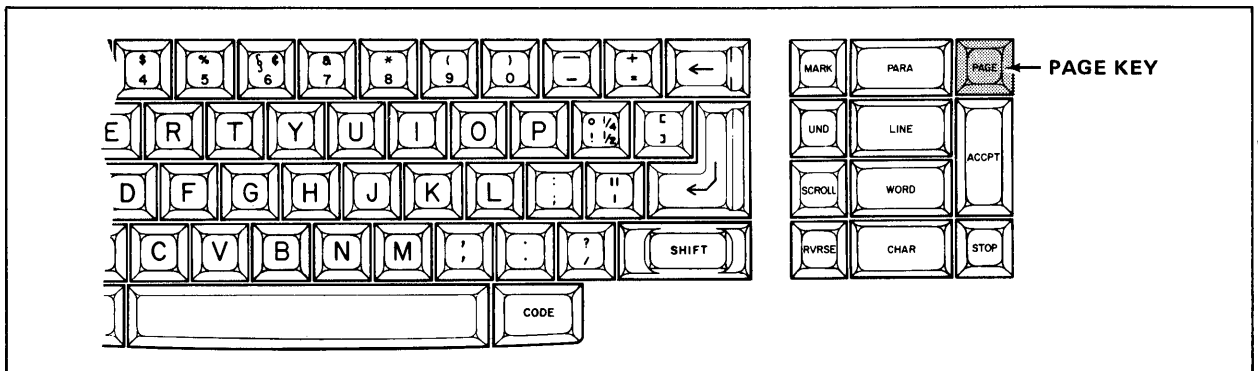

The PAGE Key
Illustration II-6

- Step 3** **TOUCH** the PAGE key several times and watch the screen to see the highlighting move.
- MOVE** the highlighting to the **INDEX: TrainingDisc** (touch the PAGE key).

Scrolling Forward

The INDEX will display twenty titles at one time. If there are more than twenty documents on the disc, you can look at the rest of the titles by touching the SCROLL key (see Illustration II-7 below).

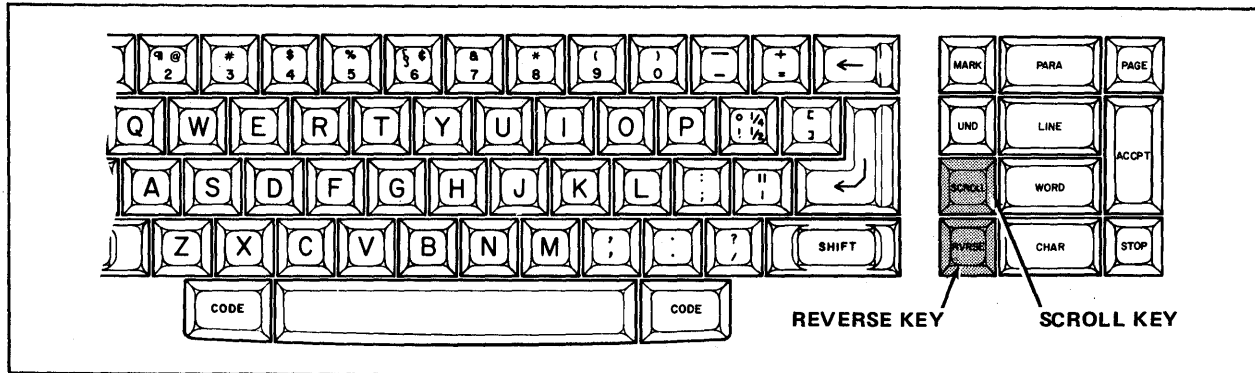

The SCROLL Key
Illustration II-7

Step 4 TOUCH the SCROLL key.

Result The INDEX displays another group of titles.

LOOK at the bottom of the screen. The words END OF INDEX let you know that you've seen all the titles in the INDEX.

Scrolling Backward

When you've used SCROLL to look at the next group of titles, you can use the RVRSE (Reverse) key and SCROLL to look at the previous titles.

Step 5 HOLD down the RVRSE key while you touch the SCROLL key.

Result The INDEX displays the first group of titles again.

Selecting a Title

You tell the system which document you want to work with by highlighting the title. To do this, you use the LINE key (see Illustration II-8 below).

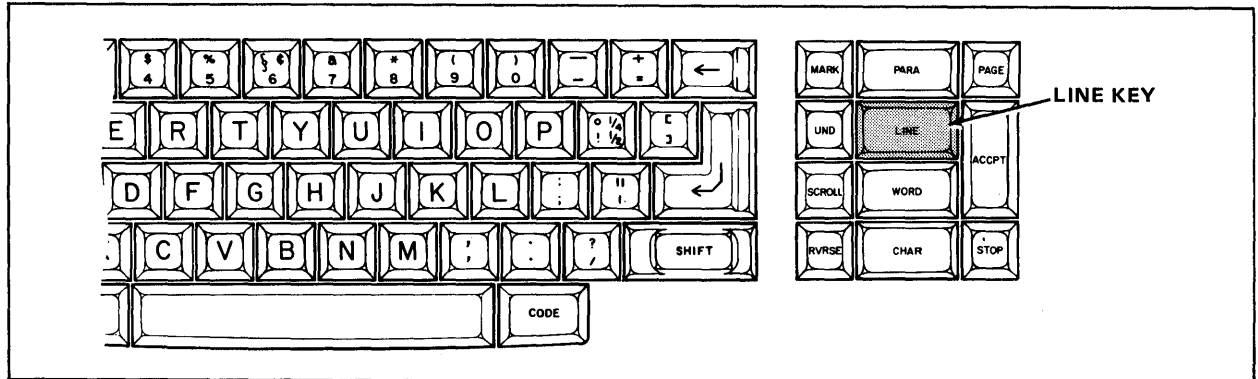

The LINE Key
Illustration II-8

- Step 6** **TOUCH** the LINE key once.
- Result The first document title is highlighted.
- HOLD** down the LINE key.
- Result The highlighting quickly moves down the document titles.
- HOLD** down the RVRSE key while you touch the LINE key.
- Result The highlighting moves back up the INDEX.

**REVIEW OF
USING THE ACTIVITY PAGE**

This page is a review of the procedures you've learned in this part of the lesson. Read through the procedures to make sure you understand them. Then go on with the lesson.

To move the highlighting from one disc station to another:

TOUCH the PARA key.

To move the highlighting from the ACTIVE LIST to the INDEX, and back again:

TOUCH the PAGE key.

To move the highlighting to any one title in the INDEX:

TOUCH the LINE key or RVRSE and LINE keys.

To scroll to the end (bottom) of a long INDEX:

TOUCH the SCROLL key.

To scroll backward through a long INDEX:

HOLD down the RVRSE key and touch the SCROLL key.

THE ACTIVE LIST

Using the INDEX is like opening a file cabinet and seeing every document. In practice, however, you wouldn't work with all the documents at one time. You'd go to the file cabinet and pull out only the documents you wanted to work with.

You can do the same thing by taking documents from the INDEX and putting them in the ACTIVE LIST. The difference is that on the 860 the original document stays on the disc. The document you work with is a duplicate.

The ACTIVE LIST holds up to ten document titles. Right now, the ACTIVE LIST is blank because you haven't taken any documents from the INDEX. In the steps below, you'll learn to put documents in the ACTIVE LIST and recall them to the screen.

Moving a Document to the Active List

- | | | |
|--------|--------------|---|
| Step 1 | MOVE | the highlighting to INDEX: TrainingDisc , if it isn't there now. (Use the PAGE key.) |
| | TOUCH | the LINE key until DOC A is highlighted. (If you go too far, hold down RVRSE while you touch LINE.) |
| | TOUCH | the ACCPT key to tell the 860 this is the document you want. |
| | Result | The highlighting moves from INDEX to ACTIVE LIST, and the title DOC A is placed in the ACTIVE LIST (see Illustration II-9 on the next page). |

Lesson Two--ACTIVITY PAGE

The ACTIVE LIST displays important information about each document. It tells you the title of the document, the type of document, which disc the document is on, the total number of pages, the usage of the document, and the number of sectors the document takes up on the disc.

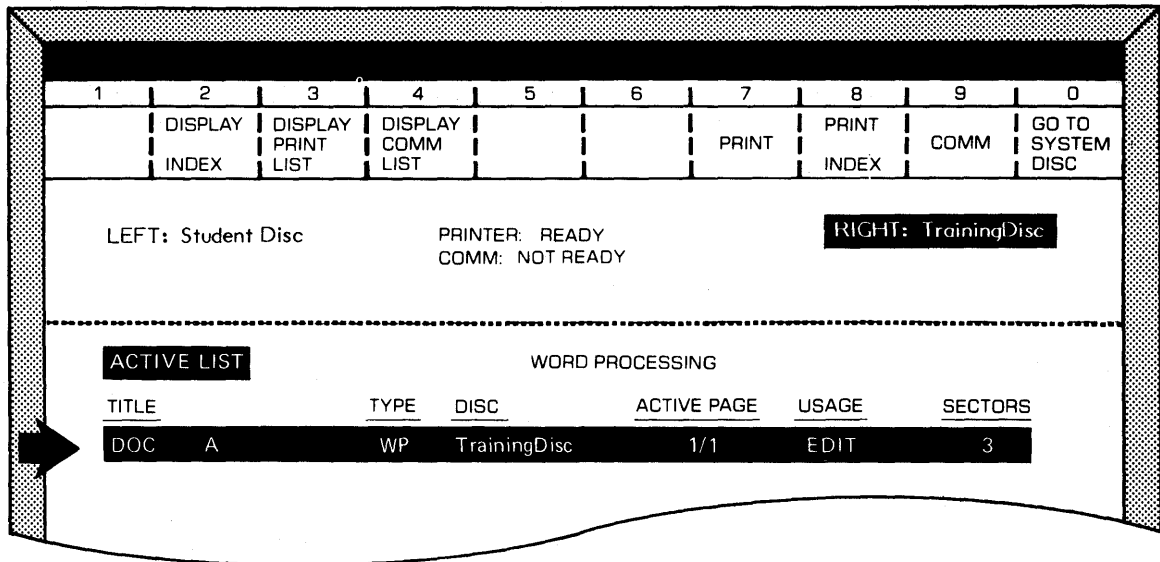

Document DOC A Highlighted on the ACTIVE LIST
Illustration II-9

Step 2 LOOK at the ACTIVE LIST. The USAGE for DOC A is shown as EDIT. Since the document was stored, the 860 assumes you want to "edit" the document.

NOTICE that the TYPE is WP, indicating that the document was typed with the Word Processing software.

Moving a document to the ACTIVE LIST is like taking an unopened file to your desk. Now you're ready to bring the document to the screen, or, open the file.

Displaying a Document

Step 3 **TOUCH** the ACCPT key.

Result The document is displayed on the screen (see Illustration II-10 below).

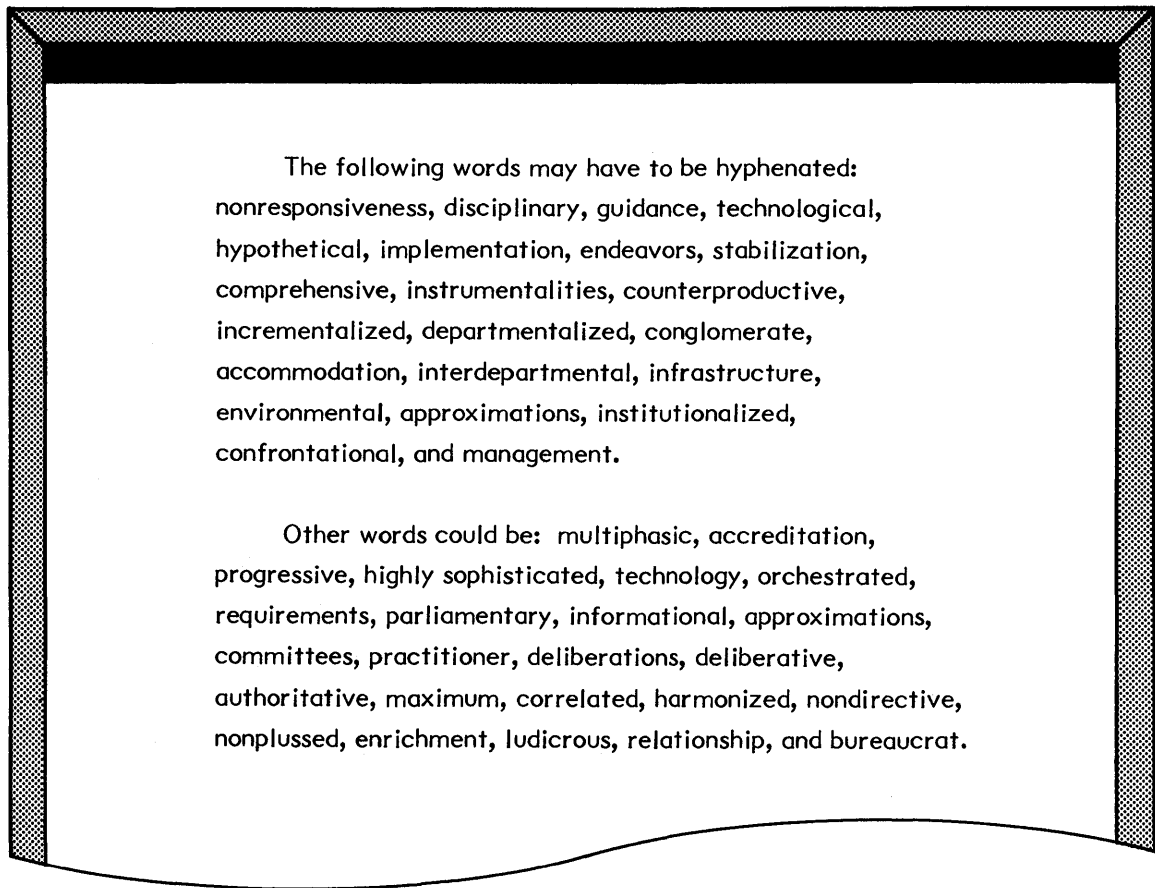

*Document DOC A on the Screen
Illustration II-10*

Removing a Document from the Screen

When you've finished looking at **DOC A**, you can remove it from the screen by using the following steps:

Step 4 TOUCH the STORE key.

Result The document disappears from the screen and the Activity Page is displayed. The title **DOC A** is still in the ACTIVE LIST and the Command Line displays the message:

STORE DOCUMENT?

If this were a new document, you would now touch the ACCPT key in order to store the document. Since the original document is already stored on disc, you may simply delete the duplicate from the ACTIVE LIST.

Deleting Documents from the ACTIVE LIST

To delete (clear) the document from the ACTIVE LIST, you will answer "no" to the message STORE DOCUMENT? by touching the orange STOP key (see Illustration II-11 below).

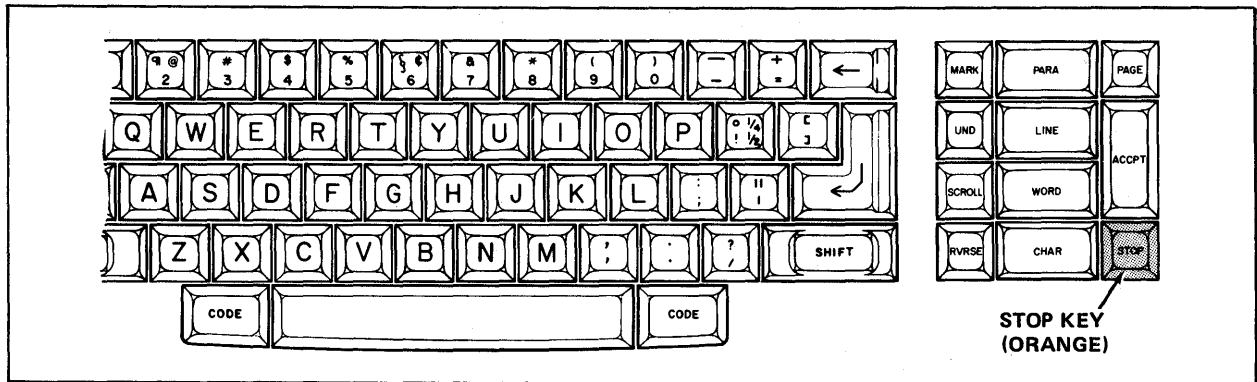

The STOP Key
Illustration II-11

Step 5 TOUCH the STOP key to tell the 860 you don't want to STORE the document.

Result The Command Line message disappears, but **DOC A** is still in the **ACTIVE LIST**.

Now you'll instruct the 860 to delete (clear) the highlighted document in the **ACTIVE LIST**. To do this, you will use the **DEL (Delete)** key (see Illustration II-12 below).

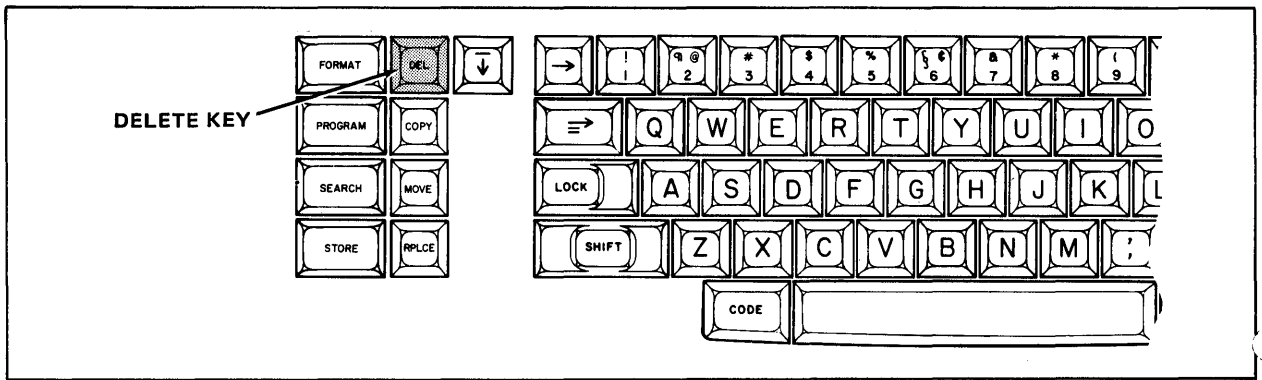

The DEL (Delete) Key
Illustration II-12

TOUCH the DEL (Delete) key.

Result The Command Line now displays:

CLEAR DOCUMENT?

TOUCH the ACCPT key to answer "yes".

Result The title is deleted (cleared) from the **ACTIVE LIST**.

PRACTICE EXERCISE

In the practice exercise below, you'll recall the document you typed in Lesson One. The document is on your Student Disc, so you will need to switch to the other disc station, then move the highlighting from ACTIVE LIST to INDEX. (The steps for doing this are given below.)

- Step 1** **TOUCH** the PARA key to switch to **LEFT: Student Disc.**
- TOUCH** the PAGE key to move the highlighting to INDEX.
- Step 2** **TOUCH** the LINE key to highlight the document titled **NAME.**
- TOUCH** the ACCPT key to tell the 860 this is the document you want.
- Result The title is brought to the ACTIVE LIST and is highlighted.
- TOUCH** the ACCPT key again.
- Result The document is brought to the screen.
- Step 3** **TOUCH** the STORE key to remove the document from the screen.
- LOOK** at the Command Line at the top of the screen. The 860 is asking you if you want to STORE DOCUMENT? Since the document is already stored on the disc, you will answer "no."
- TOUCH** the STOP key to answer "no" to the question STORE DOCUMENT?
- TOUCH** the DEL key and the ACCPT key.
- Result The document title **NAME** is removed from the ACTIVE LIST. The original is still stored in the INDEX.

Moving More Than One Document to the Active List

If you know you're going to be working with several documents, there's a simple way to move them all to the ACTIVE LIST at one time. To try this, you will need to switch back to the INDEX of your Training Disc, using the steps below.

- Step 1** **TOUCH** the PARA key to switch back to the Training Disc.

- TOUCH** the PAGE key to highlight INDEX.

- Step 2** **HIGHLIGHT** **DOC D** (use the LINE key).

The MARK key (see Illustration II-13 below) is used to tell the 860 that you want to select several documents. You can put up to ten documents in the ACTIVE LIST at one time.

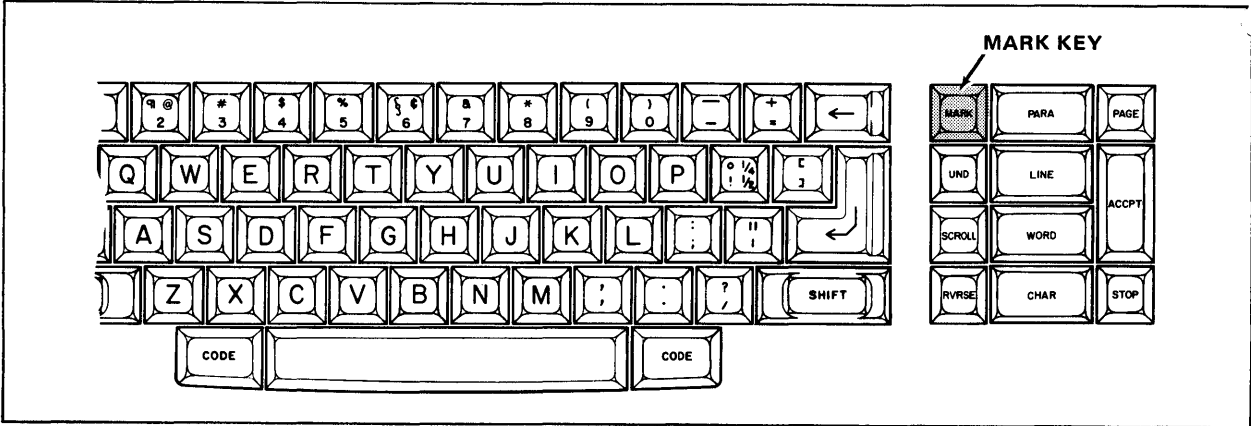

The MARK Key
Illustration II-13

- Step 3** **TOUCH** the MARK key.

- Result** The document title **DOC D** is blinking, indicating that you have marked it.

Lesson Two--ACTIVITY PAGE

To help you keep track of the number of documents you have marked, the 860 counts them for you.

LOOK at the first line of the INDEX. On the right, **MARKED DOCUMENTS: 1** is shown, indicating you have marked one document (see Illustration II-14 below).

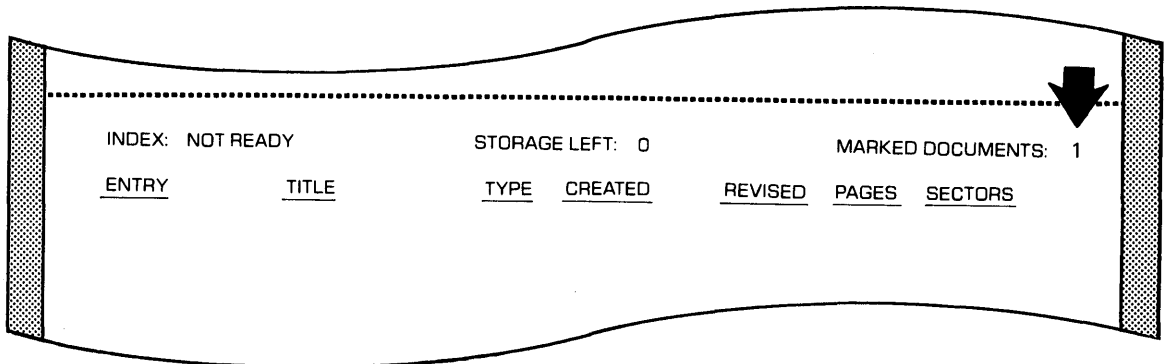

The Marked Documents Counter
Illustration II-14

Step 4 **HIGHLIGHT** the title **DOC E** (use the LINE key).

TOUCH the MARK key.

Result **DOC D** is still highlighted and **DOC E** is blinking. The **MARKED DOCUMENTS** counter now shows 2.

HIGHLIGHT the title **DOC F**.

TOUCH the MARK key.

Result Three titles are highlighted and the **MARKED DOCUMENTS** counter shows 3.

When you have all the titles marked, you tell the 860 that you want to put them in the **ACTIVE LIST** by touching the **ACCPT** key.

Step 5 **TOUCH** the **ACCPT** key.

Result All the marked titles are placed in the **ACTIVE LIST**.

Clearing the Active List

When you don't want to work with any of the documents in the ACTIVE LIST, you can clear (delete) all the documents from the ACTIVE LIST at one time. To do this you use the DEL key with no titles highlighted.

Step 1 **TOUCH** the STOP key to remove the highlighting from the titles on the ACTIVE LIST.

TOUCH the DEL key.

Result The Command Line displays:

CLEAR ENTIRE ACTIVE LIST?

TOUCH the ACCPT key to answer "yes".

Checking the Amount of Disc Space (Storage) Left

The 860 divides each disc into sectors. Since each sector holds about 500 characters, so a full page of typing takes about four sectors.

The 860 always shows you how many sectors are left on a disc, so you will know how much information you can record on the disc before running out of room.

Step 1 TOUCH the PARA key to move the highlighting to your Student Disc.

LOOK at the INDEX. In between the headings INDEX and MARKED DOCUMENTS are the words STORAGE LEFT (see Illustration II-15 below).

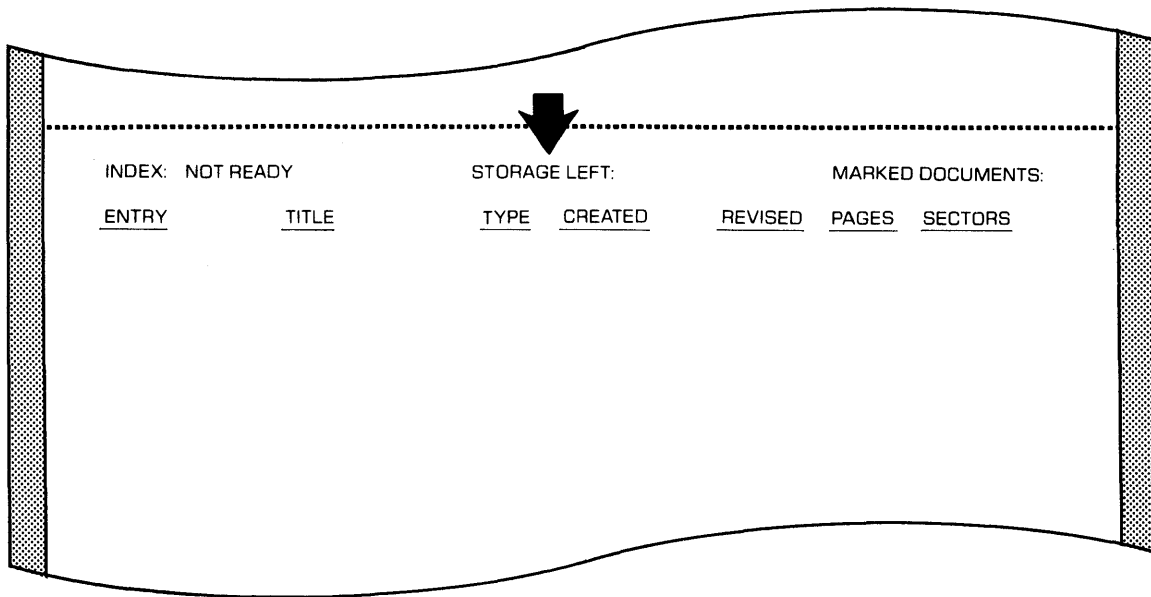

The STORAGE LEFT Heading
Illustration II-15

The number after STORAGE LEFT represents the amount of room left on the disc. If the number indicates there's only a little room left, you wouldn't want to start a long document on the disc. When the number after STORAGE LEFT is less than 65, the 860 will also display a message in the Command Line to let you know that there are LESS THAN 65 SECTORS REMAINING. When this happens, you know the disc is getting full. You can get another disc with more room on it, or delete some documents from the full disc to make more room.

Using a Write Protected Disc

Sometimes you want to make sure that the documents on a disc will never be deleted or changed. Your Training Disc is an example of a disc that should never be changed or erased. It was "write protected" by removing the Write Protect Tape when it was packaged with your manuals.

Step 2 TOUCH the PARA key to move back to the Training Disc.

LOOK at the INDEX and find the words WRITE PROTECTED DISC (see Illustration II-16 below).

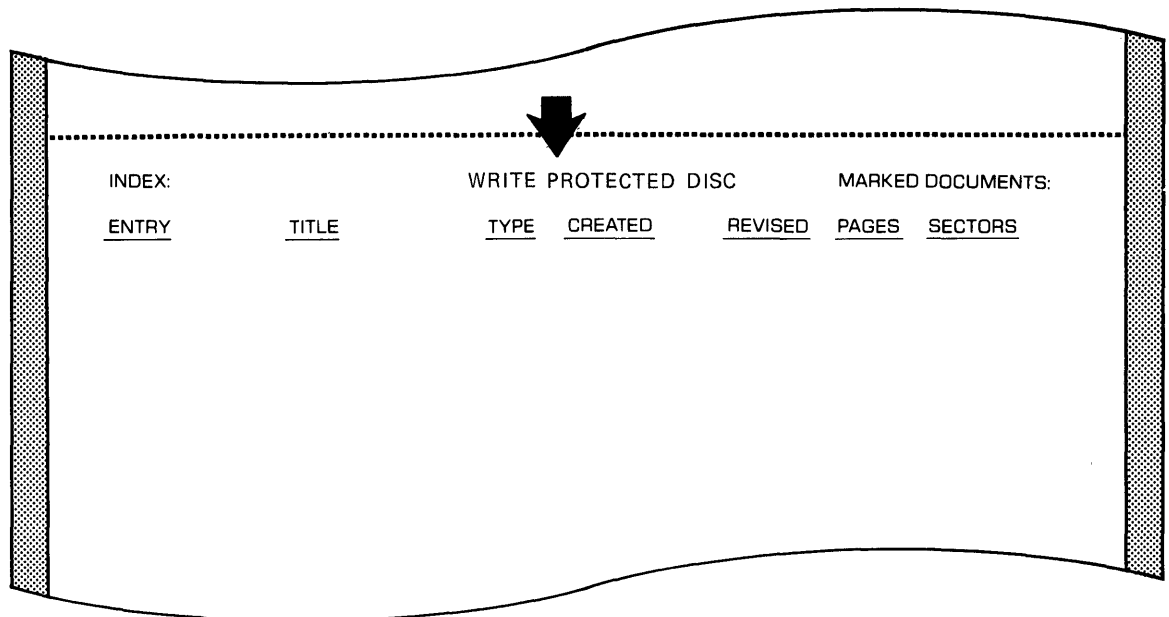

The WRITE PROTECTED DISC Heading
Illustration II-16

If you do not see the message WRITE PROTECTED DISC, take the disc out of the disc station and remove the tape (see Illustration I-17 on Page 1-21 of Lesson One).

When you see WRITE PROTECTED DISC instead of STORAGE LEFT, it means the disc has been protected against being written (recorded) on. When you WRITE PROTECT a disc, you can recall documents and print documents, but you cannot begin new documents or revise old ones. Removing the Write Protect Tape protects the disc from change.

Lesson Two--ACTIVITY PAGE

You have now completed Lesson Two. On the next pages there are Points to Remember and an Action Summary for you to review.

There is also a Progress Check for you to complete. If you should answer any of the questions incorrectly, turn to the page indicated in the answer and review the information.

POINTS TO REMEMBER

- The Command Line displays messages and prompts. (Page 2-4)
- The Status Line tells you about the Disc Stations and the Printer. It displays the name of a disc and its location (Left or Right Disc Station) and whether the Printer is ready to use. (Page 2-7)
- The INDEX lists every document stored on a disc. (Page 2-9)
- The first line of the INDEX shows the name of the disc and the amount of STORAGE LEFT. When the amount of STORAGE LEFT is less than 65 sectors, it is not a good idea to record more material on the disc. (Page 2-22)
- The ACTIVE LIST holds any document (or documents) that you are actively working with (up to 10). (Page 2-13)
- The PARA key switches the highlighting from one disc station to the other. (Page 2-8)
- The PAGE key moves the highlighting from the ACTIVE LIST to the INDEX and back. (Page 2-9)
- The LINE key moves the highlighting to different titles (also the RVRSE and the LINE keys). (Page 2-13)
- The MARK key marks document titles for some kind of action (so that a group of documents may be moved at one time). (Page 2-19)
- When you remove the WRITE PROTECT tape from a disc, you can recall or print documents; but you cannot change documents or begin new ones. (Page 2-23)

ACTION SUMMARY

You may want to make a copy of this ACTION SUMMARY and keep it on your desk for quick reference.

The Activity Page is "home base" for working with discs and documents. It shows you the names of the discs in the controller. In addition, the INDEX shows you a list of the documents on your discs and the ACTIVE LIST shows the documents you are working with.

To switch from one disc station to another:

- | | | |
|--------|-------|--|
| Step 1 | LOOK | at status line (near the top of the Activity Page) to see the names of the discs in the LEFT and RIGHT disc stations. (The highlighting tells you which disc is currently selected.) |
| Step 2 | TOUCH | the PARA key to switch from one disc to another. |
| | LOOK | at the INDEX to see the titles of the documents on the disc. |

To recall documents to the screen:

- | | | |
|--------|-----------|--|
| Step 1 | HIGHLIGHT | the INDEX of the disc containing the document (if the ACTIVE LIST is highlighted, touch the PAGE key). |
| Step 2 | HIGHLIGHT | the title of the document, using one of the following methods: <ul style="list-style-type: none">● Touch the LINE key to highlight the titleOR● Touch SCROLL to scroll through a long INDEX and then touch LINE to highlight the title |
| Step 3 | TOUCH | the ACCPT key to put the highlighted document in the ACTIVE LIST. |
| Step 4 | TOUCH | the ACCPT key again to recall the highlighted document to the screen. |

ACTION SUMMARY -- CONTINUED

If the document on the screen is a new document, you will need to store it in the INDEX. If the document is already stored in the INDEX, you can clear the document without storing it again.

To remove documents from the screen:

- Step 1 TOUCH** the STORE key to put the document in the ACTIVE LIST.
- Step 2 REMOVE** the document from the ACTIVE LIST, using one of the following methods:
- If the document is new, touch the ACCPT key to store the document in the INDEX
 - OR**
 - If the document is already in the INDEX, clear it from the ACTIVE LIST as follows:
 - Touch the STOP key
 - Touch the DEL key
 - Touch the ACCPT key

(This page is intentionally left blank.)

PROGRESS CHECK

Answer each question by filling in the blank with the correct answer, then compare your answers with those on Page 2-35. You should write your answers on a separate piece of paper to avoid marking up the manual.

1. The _____ shows the titles of every document stored on the disc.
2. The _____ shows the titles you have selected to work with.
3. The _____ key is used to highlight document titles.
4. When there are more than twenty documents on a disc, the _____ key may be used to move through the INDEX in sections of twenty titles at a time.
5. If a disc has been protected against accidental erasure or revision, the message _____ will display in place of STORAGE LEFT.
6. The _____ key is used to switch from the INDEX of one disc to the INDEX of the other disc.

(This page is intentionally left blank.)

ANSWERS TO PROGRESS CHECK

If you are uncertain or answered a question incorrectly, refer to the pages listed to review the original material. When you feel comfortable with the material, return to this point in the lesson and continue.

1. The INDEX shows the titles of every document stored on the disc. (Page 2-9)
2. The ACTIVE LIST shows the titles you have selected to work with. (Page 2-13)
3. The LINE key is used to highlight document titles. (Page 2-11)
4. When there are more than twenty documents on a disc, the SCROLL key may be used to move through the INDEX in sections of twenty titles at a time. (Page 2-10)
5. If a disc has been protected against accidental erasure or revision, the message Write Protected Disc will display in place of STORAGE LEFT. (Page 2-23)
6. The PARA key is used to switch from the INDEX of one disc to the INDEX of the other disc. (Page 2-8)

(This page is intentionally left blank.)

Xerox 860 IPS Operator Manual
Book One: Fundamentals

Lesson Three – Copy/Delete
Copying and Deleting Documents and Discs

LESSON THREE

COPY/DELETE

Copying and Deleting Documents and Discs

OBJECTIVES

After finishing this Lesson, you will be able to:

- copy a document from one disc to another disc
 - delete (erase) one document from the INDEX of a disc
 - copy all the documents from one disc to another disc
 - delete the entire INDEX on a disc
 - use the MARK key to copy or delete several documents at one time
-

Materials Needed

For this lesson you will need:

- System Disc
- Student Disc
- Training Disc
- Reference Manual

BEFORE YOU BEGIN

Check to be sure your 860 is set up as follows:

- System ON.
- ACTIVITY PAGE on screen.
- **INDEX: Student Disc** highlighted.

If your 860 is set up correctly, the Activity Page will be displayed on your screen. It should look about like Illustration III-1 below.

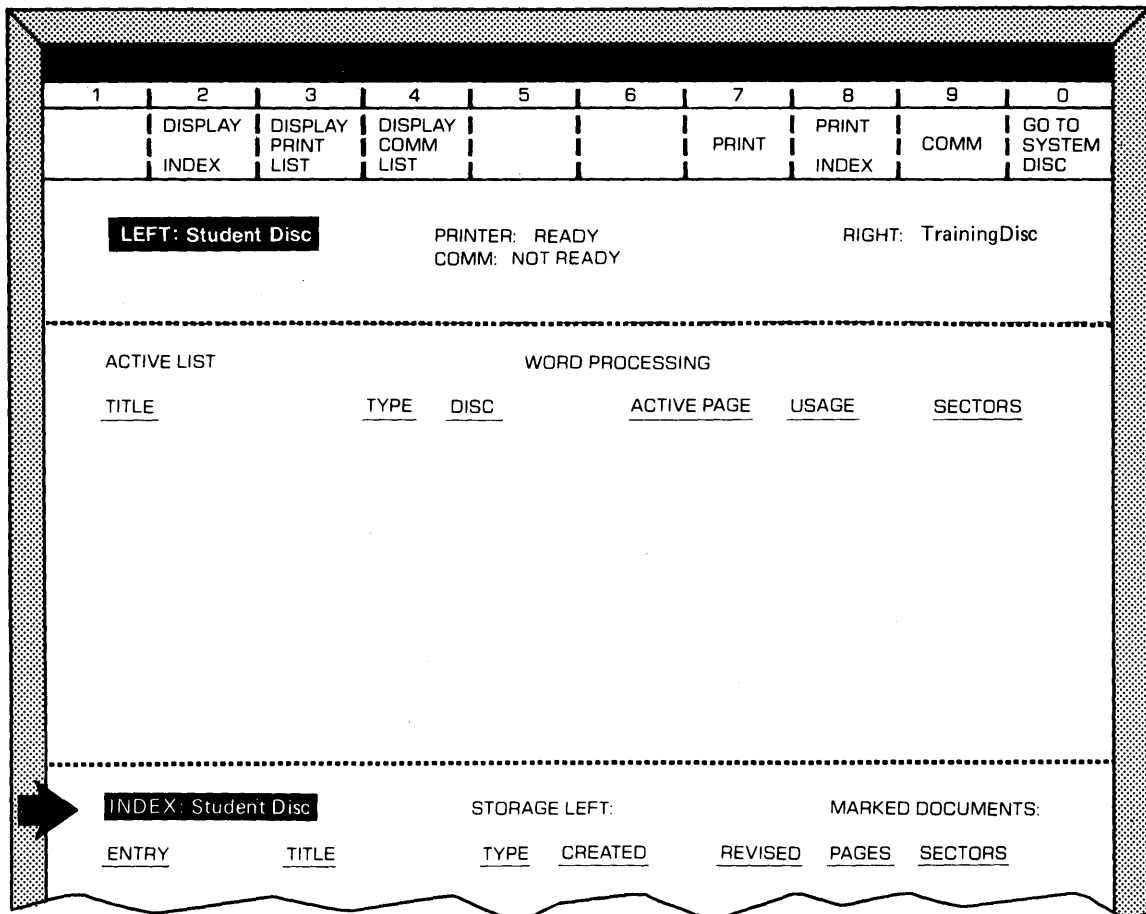

The Activity Page
Illustration III-1

If your 860 is turned off or has XEROX on the screen, follow the instructions on page 31 in Lesson One to load the software. When the Activity Page is on the screen, remove the System Disc and insert your Student Disc in left Disc Station and your Training Disc in the right Disc Station.

Then return to this page and go on with the lesson.

COPYING SINGLE DOCUMENTS

In this lesson you'll learn to copy and delete documents. You may need to copy a document for another operator or make copies for storage and future use. With the 860 Information Processing System, you can easily make copies of documents or discs. First, you'll copy individual documents, then you'll copy the entire disc onto another disc.

To copy a document, you highlight the title in the INDEX and touch the COPY key (see Illustration III-2 below).

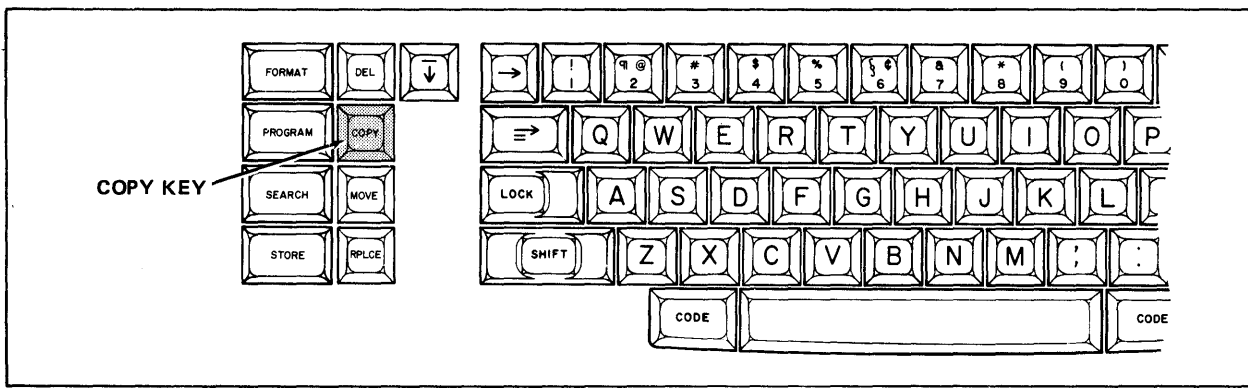

The COPY Key
Illustration III-2

Step 1 HIGHLIGHT the INDEX of the Training Disc (use the PARA key).

HIGHLIGHT the document titled **MEMO A**.

Step 2 TOUCH the COPY key (see Illustration III-2 above).

Result The Command Line displays:

COPY DOCUMENT TO Student Disc

TOUCH the ACCPT key.

Result The Command Line displays:

COPYING MEMO A

When the message disappears, the document has been copied.

- Step 3** **TOUCH** the PARA key to highlight the INDEX of your Student Disc.
- LOOK** at the screen. The document title **MEMO A** has been copied and recorded on your Student Disc. It is shown at the top of the INDEX with the highest entry number.

DELETING SINGLE DOCUMENTS

You also need to know how to delete (erase) documents that are no longer needed. To delete a document, you highlight the title in the INDEX and touch the DEL (delete) key. In the exercise below, you'll delete the document that you just copied.

- Step 1** **HIGHLIGHT** the INDEX for Student Disc.

HIGHLIGHT the document titled **MEMO A**.

- Step 2** **TOUCH** the DEL key.

Result The Command Line displays:

DELETE DOCUMENT?

TOUCH the ACCPT key.

Result The title and the entry number are removed from the INDEX.

Mistake? If you accidentally delete the wrong document you can get it back. Whenever you delete a document, it is moved to the Backup Index (a special Index on the disc). You use the System Disc to do this. This is explained in detail in Lesson 8.

PRACTICE EXERCISE

In this practice exercise, you will copy a document from the Training Disc onto your Student Disc. Then you will delete it.

Copy the document **SOURCES** to your Student Disc, using the steps below.

- Step 1** **HIGHLIGHT** the INDEX of the Training Disc (use the PARA key to switch disc stations).
- HIGHLIGHT** the document **SOURCES** (use the LINE key).
- Step 2** **TOUCH** the COPY key. The Command Line displays the message COPY DOCUMENT TO Student Disc.
- TOUCH** the ACCPT key. The Command Line displays the message COPYING SOURCES.
- Step 3** **HIGHLIGHT** the INDEX of the Student Disc (use the PARA key).
- CHECK** the INDEX of your Student Disc. **SOURCES** should be listed.

Delete the document **SOURCES** from your Student Disc, using the steps below.

- Step 4** **CHECK** to be sure the **INDEX: Student Disc** is highlighted.
- HIGHLIGHT** the document titled **SOURCES**.
- Step 5** **TOUCH** the DEL key.
- TOUCH** the ACCPT key.

COPYING AND DELETING MORE THAN ONE DOCUMENT

In the Activity Page lesson, you used the MARK key to move several documents at one time to the ACTIVE LIST. You can also use the MARK key to copy or delete several documents at one time.

Copying More Than One Document

You can use the MARK key to copy several documents at a time. Follow the steps below to copy three documents from your Training Disc to your Student Disc.

- | | | |
|---------------|------------------|--|
| Step 1 | HIGHLIGHT | the INDEX of your Training Disc (use the PARA key to switch disc stations). |
| Step 2 | HIGHLIGHT | the document JENSON . |
| | TOUCH | the MARK key. |
| | Result | The document title JENSON is blinking. |
| | HIGHLIGHT | the document FLIGHT . |
| | TOUCH | the MARK key. |
| | HIGHLIGHT | the document SLADE GAS . |
| | TOUCH | the MARK key. |
| | Result | The three document titles are marked and the MARKED DOCUMENTS counter indicates 3. |
| Step 3 | TOUCH | the COPY key. |
| | TOUCH | the ACCPT key. |
| | Result | the 860 copies the documents from the Training Disc to the Student Disc. When the COPYING message disappears from the Command Line, the copying is complete. |
| | TOUCH | the PARA key to switch to your Student Disc and see the documents in the INDEX. |

Deleting More Than One Document

You can use the MARK key to delete several documents at one time. To do this, you highlight the title and touch MARK for each document to be deleted, then touch the DELEte key, and the ACCPT key.

Follow the steps below to delete three documents from your Student Disc.

Step 1 **CHECK** that **INDEX: Student Disc** is highlighted.

Step 2 **HIGHLIGHT** the title **JENSON**.

TOUCH the MARK key.

HIGHLIGHT the title **FLIGHT**.

TOUCH the MARK key.

HIGHLIGHT the title **SLADE GAS**.

TOUCH the MARK key.

Result You have highlighted and marked three document titles.

Step 3 **TOUCH** the DEL key.

TOUCH the ACCPT key.

Result The 860 will delete the three documents.

COPYING AN ENTIRE DISC

Copying an entire disc is very similar to copying a single document. You use the same steps as copying single documents. When you copy an entire disc, all of the documents on one disc will be added to the other disc. Copying will not erase any of the documents on either disc.

In the steps that follow, you will be copying all the documents from your Training Disc onto your Student Disc.

Step 1 **HIGHLIGHT** the INDEX for the Training Disc (use the PARA key).

If one title is highlighted, the system will only copy that particular document. By highlighting the INDEX but not highlighting any titles, you tell the system you want to copy the entire disc.

TOUCH the STOP key to make sure no titles are highlighted.

Step 2 **TOUCH** the COPY key.

Result The Command Line displays

```
COPY TrainingDisc TO Student Disc
```

TOUCH the ACCPT key to answer "yes".

Result As each document is being copied, the message COPYING and the document title will appear in the Command Line.

The titles from the Training Disc are now listed on the INDEX of your Student Disc with new entry numbers.

DELETING THE ENTIRE INDEX

On occasion, you may be through with all the documents on a disc and want to delete them. It's easy to delete all the documents. However, as a safety precaution, the system will ask you to confirm that you want to delete everything.

In the steps that follow, you'll delete the INDEX of your entire Student Disc.

Step 1 REMOVE your Training Disc and put it in its protective envelope.

HIGHLIGHT the INDEX for the **Student Disc** (use the PARA key).

TOUCH the STOP key to make sure no titles are highlighted.

Remember If one title is highlighted, the system will delete only that title (the same as when you are copying).

Step 2 TOUCH the DEL key.

Result The Command Line displays

DELETE ENTIRE INDEX?

TOUCH ACCPT to answer "yes".

Result The Command Line displays

ARE YOU SURE?

The system is asking you to double check that you are deleting the correct disc. Check the INDEX title again, to make sure you are deleting the Student Disc. If you discover that you are going to delete the wrong disc, tell the system "no" by touching the STOP key. However, if you accidentally delete documents that you do want to keep, you can go to the Backup Index and get them back.

TOUCH the ACCPT key.

Result The 860 erases the entire INDEX of your Student Disc. All of the documents and their entry numbers go to the Backup Index.

COPYING DOCUMENTS WITH THE SAME TITLES

As you recall, each document in the INDEX must have its own title. Two documents cannot have the same title. If you try to copy a document to a disc that has another document with the same title, the 860 will stop and display the message TITLE USED -- COPY OVER IT?

When this happens, you can do one of two things. You can touch the ACCPT key to copy the new document over the existing one, or you can type a new title for the document you are copying to be stored under. If you type a new title, both documents will be stored in the INDEX.

TRYING TO USE A WRITE PROTECTED DISC

The Training Disc has been protected by removing the Write Protect Tape. You are unable to record (write) information on the disc as long as this tape is removed. At the same time, you cannot delete any documents or copy any documents onto a protected disc. If you try to, the system will tell you it cannot honor your instructions by displaying WRITE PROTECTED DISC -- CHECK DISC in the Command Line.

If you need to delete information from a protected disc, you have to put the Write Protect Tape back on the disc.

BEFORE YOU GO ON

For the rest of the training exercises in Book One, you will need to copy all the documents on your Training Disc onto your Student Disc. Do so now, using the steps below.

Step 1 **INSERT** your Training Disc.

TOUCH the PARA key to move to your Training Disc.

Step 2 **TOUCH** the COPY key.

CHECK that the Command Line displays:

```
COPY TrainingDisc TO Student Disc
```

If it does not, touch STOP twice and start over.

TOUCH the ACCPT key.

When the copy process is finished, the message COPYING will disappear from the Command Line.

Step 3 **REMOVE** your Training Disc from the Controller and place it back in its protective envelope.

You have now completed Lesson Three. On the next pages there are Points to Remember and an Action Summary for you to review.

There is also a Progress Check for you to complete. If you should answer any of the questions incorrectly, turn to the page indicated in the answer and review the information.

POINTS TO REMEMBER

- You can copy individual documents or copy one disc onto another disc. (Page 3-4 and 3-7)
- You can delete individual documents from the INDEX by highlighting the document title, touching the DELEte key and touching the ACCPT key. (Page 3-5)
- You can delete the entire INDEX by highlighting the INDEX, touching STOP (to be sure no document titles are highlighted), touching the DELEte key once and touching the ACCPT key twice. (Page 3-10)
- When you delete an entire INDEX, all the documents and their entry numbers go to the Backup Index. (Page 3-10)
- To copy or delete more than one document at a time, you use the MARK key. (Page 3-7)
- You cannot delete any documents from or copy any documents to a Write Protected Disc. (Page 3-11)

ACTION SUMMARY

You may want to make a copy of this ACTION SUMMARY and keep it on your desk for quick reference.

Documents may be copied from one disc to another. You can copy just one document, several documents, or all the documents in the INDEX. When documents are copied, they will be added to the INDEX of the other disc.

To copy individual document(s):

- Step 1** **HIGHLIGHT** the INDEX of the disc you will copy from as follows:
- Touch PARA to switch from one disc to the other
 - Touch PAGE to move from ACTIVE LIST to INDEX
- Step 2** **HIGHLIGHT** the document title(s) using one of the following methods:
- Touch the LINE key to highlight the title
OR
 - Touch the LINE key to highlight the first title, then touch the MARK key. Continue to use the LINE and MARK keys until all titles are highlighted and marked.
- Step 3** **TOUCH** the COPY key.
- TOUCH** the ACCPT key.

Note: If the title of the document being copied is already on the other disc INDEX, the Command Line will display TITLE USED -- COPY OVER IT? Should this occur, you can type a new title for the copied document and touch ACCPT, or touch ACCPT to copy the new document over the old

To copy all documents in the INDEX:

- Step 1** **HIGHLIGHT** the INDEX of the disc you will copy from as follows:
- Touch PARA to switch from one disc to the other
 - Touch PAGE to move from ACTIVE LIST to INDEX
- TOUCH** STOP to be sure no titles are highlighted.
- Step 2** **TOUCH** the COPY key.
- TOUCH** the ACCPT key.

ACTION SUMMARY — CONTINUED

You can delete documents from the INDEX one at a time or in a group of up to 20 documents. You can also delete the entire INDEX. Any time you delete documents, they will be put in the Backup Index.

To delete individual documents:

- Step 1 HIGHLIGHT the INDEX of the disc containing the documents:**
- Touch PARA to switch from one disc to the other
 - Touch PAGE to move from ACTIVE LIST to INDEX
- Step 2 HIGHLIGHT the title of the document(s) using one of the following methods:**
- Touch the LINE key to highlight the title
OR
 - Touch the LINE key to highlight the first title, then touch the MARK key. Continue to use the LINE and MARK keys until all titles are highlighted and marked.
- Step 3 TOUCH the DEL key.**
- TOUCH the ACCPT key.**

To delete all the documents in the INDEX:

- Step 1 HIGHLIGHT the INDEX of the disc containing the documents:**
- Touch PARA to switch from one disc to the other
 - Touch PAGE to move from ACTIVE LIST to INDEX
- Step 2 TOUCH the STOP key to make sure no titles are highlighted.**
- Step 3 TOUCH the DEL key.**
- TOUCH the ACCPT key.**
- TOUCH the ACCPT key again.**

(This page is intentionally left blank.)

PROGRESS CHECK

Answer each question by filling in the blank with the correct answer, then compare your answers with those on Page 3-19.

Answer TRUE or FALSE. (Write T or F in the space provided.)

- ___ 1. You cannot copy the entire INDEX of a disc.
- ___ 2. You can copy a document from one disc to another.
- ___ 3. You can copy several selected documents at one time by using the MARK key.
- ___ 4. You can delete just one title from an INDEX.
- ___ 5. A WRITE PROTECTED DISC can be erased or recorded on just like any other disc.
- ___ 6. You can delete an entire INDEX on a disc.
- ___ 7. If you delete an entire INDEX, the documents are erased completely off the disc.

Write in the answers below.

- 1. If you accidentally delete the wrong document, you can find the "deleted" document in the _____.
- 2. You make a disc a WRITE PROTECTED DISC if you do not want to _____ any of the documents on it.

(This page is intentionally left blank.)

ANSWERS TO PROGRESS CHECK

If you are uncertain or answered a question incorrectly, refer to the pages listed to review the original material. When you feel comfortable with the material, return to this point in the lesson and continue.

Answer TRUE or FALSE.

- False 1. You cannot copy the entire INDEX of a disc. (Page 3-9)
- True 2. You can copy a document from one disc to another. (Page 3-4)
- True 3. You can copy several selected documents at one time by using the MARK key. (Page 3-7)
- True 4. You can delete just one title from an INDEX. (Page 3-5)
- False 5. A WRITE PROTECTED DISC can be erased or recorded on just like any other disc. (Page 3-11)
- True 6. You can delete an entire INDEX on a disc. (Page 3-10)
- False 7. If you delete an entire INDEX, the documents are erased completely off the disc. (Page 3-10)

Write in the answers below.

1. If you accidentally delete the wrong document, you can find the "deleted" document in the Back-up Index. (Page 3-5)
2. You make a disc a WRITE PROTECTED DISC if you do not want to revise or delete any of the documents on it. (Page 3-11)

(This page is intentionally left blank.)

Xerox 860 IPS Operator Manual
Book One: Fundamentals

Lesson Four – Print I
Printing Documents

LESSON FOUR

PRINT I

Printing Documents

OBJECTIVES

After finishing this Lesson, you will be able to:

- select one or more documents for printing
 - print one or more documents using the standard print options
 - look at the PRINT LIST
 - start the printer from the printer or keyboard
 - interrupt the printer when it is printing and restart it
 - print a list of the documents on your disc
-

Materials Needed

For this lesson you will need:

- System Disc
- Student Disc
- Printer and paper
- Reference Manual

BEFORE YOU BEGIN

Check to be sure your 860 is set up as follows:

- System ON.
- ACTIVITY PAGE on screen.
- **INDEX: Student Disc** highlighted.

If your 860 is set up correctly, the Activity Page will be displayed on your screen. It should look about like Illustration IV-1 below.

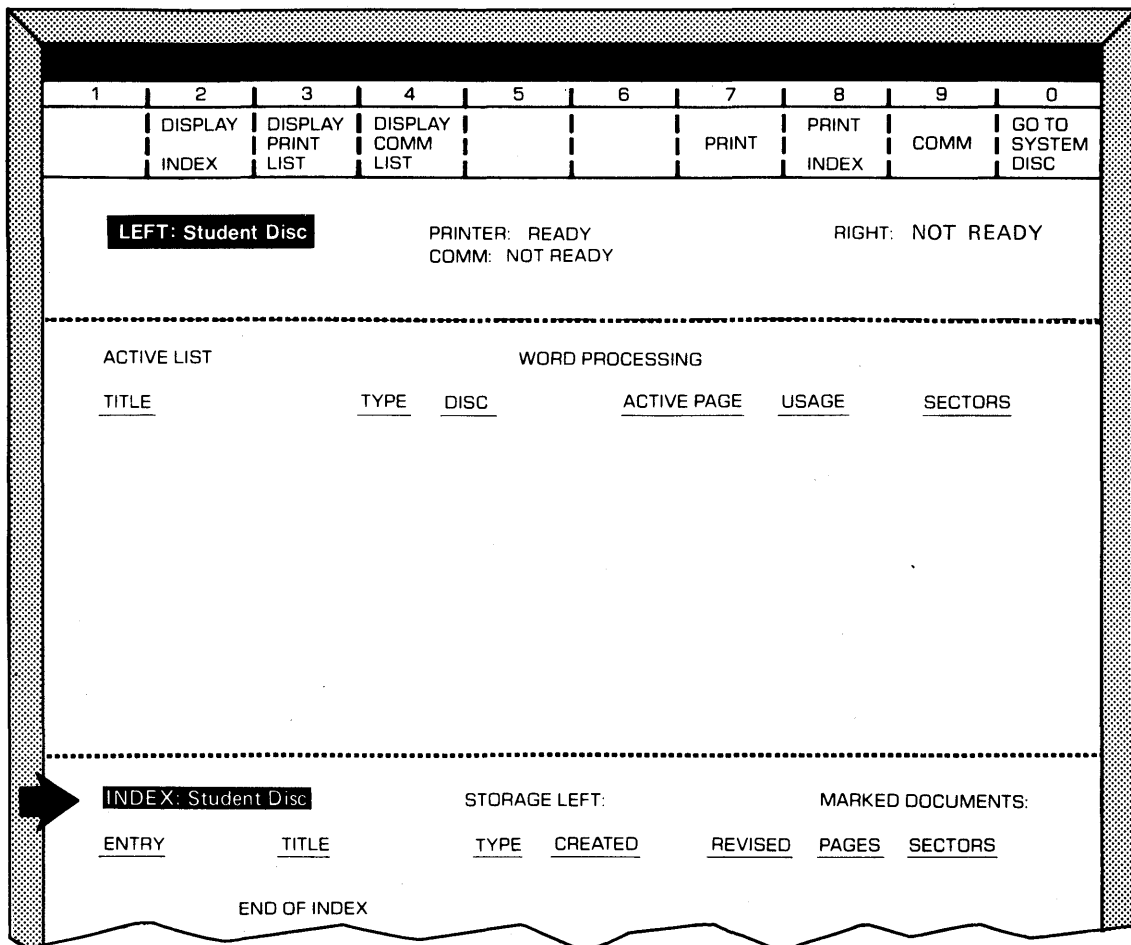

The Activity Page
Illustration IV-1

If your 860 is turned off or has XEROX on the screen, follow the instructions on page 31 in Lesson One to turn it on and load the software. When the Activity Page is on the screen, remove the System Disc and insert your Student Disc in the left Disc Station.

Then return to this page and go on with the lesson.

In this lesson, you will learn how to print documents. The instructions in the lesson assume you have a standard printer without any accessories.

If you have a PI printer, you will need to turn the printer on before you load the software. The switch is located on the back of the printer. If your printer is not turned on, turn it on now. Then reload the software using the steps below:

- Insert your System Disc.
- Hold down CODE and touch the 0 (zero) key.
- Wait for the System Disc Page to appear on the screen.
- Touch ACCPT to reload the software.

More information about the printer is given in the **Disc and Peripherals** section of the Reference Manual.

If you have an Automatic Paper Feeder (APF), simply ignore any of the instructions about inserting the paper; the APF will do all of this for you automatically. Instructions for putting paper into the APF are included in the booklet that comes with it.

If you have a Shared Printer Interface, make sure that all 860's connected to the interface are turned on and have the software loaded (see the Reference Manual, page 6-7).

PRINTING ONE DOCUMENT

On the 860, printing a document is a two step process. First you select the document for printing, then you start the printer.

After you select a document for printing, you use the information in the instruction blocks at the top of the screen (see Illustration IV-2 below).

1	2	3	4	5	6	7	8	9	0
	DISPLAY	DISPLAY	DISPLAY				PRINT	PRINT	GO TO
	INDEX	PRINT	COMM			PRINT	INDEX	COMM	SYSTEM
		LIST	LIST						DISC

*The Instruction Blocks on the Activity Page
Illustration IV-2*

Each instruction block has information in it and a number over it; the number is used with the CODE key to tell the 860 which instruction you want to give. One of the Instruction Blocks has the word PRINT inside it. (The blank boxes will be filled in later as you add new features to your Xerox 860 System.)

When you use CODE + 7 to tell the 860 to print a document, it asks you how you want the document printed by showing you the Print Options. After you select different print options or use the standard ones, the 860 waits for you to insert paper and start the printer.

You'll be using the standard print options in this lesson. Follow the steps on the next four pages to print the document titled **PRINT FIRST**.

Selecting a Document for Printing

Whenever you select a document for printing, you must have the System Disc in the Controller. When you give the print instruction (CODE + 7), the 860 will get additional information from the System Disc so that it can print the document. If the System Disc is not in the Controller, the 860 will display the message INSERT DISC "name" in the Command Line to tell you to insert the System Disc.

- Step 1** **INSERT** the System Disc in the right Disc Station.
- Step 2** **HIGHLIGHT** the document titled **PRINT FIRST** in the INDEX of the Student Disc (use the LINE key).
- LOOK** at the instruction blocks at the top of the screen. The PRINT instruction block has the number 7 over it.

You'll use either one of the CODE keys along with the number 7 key to give the print instruction (see Illustration IV-3 below).

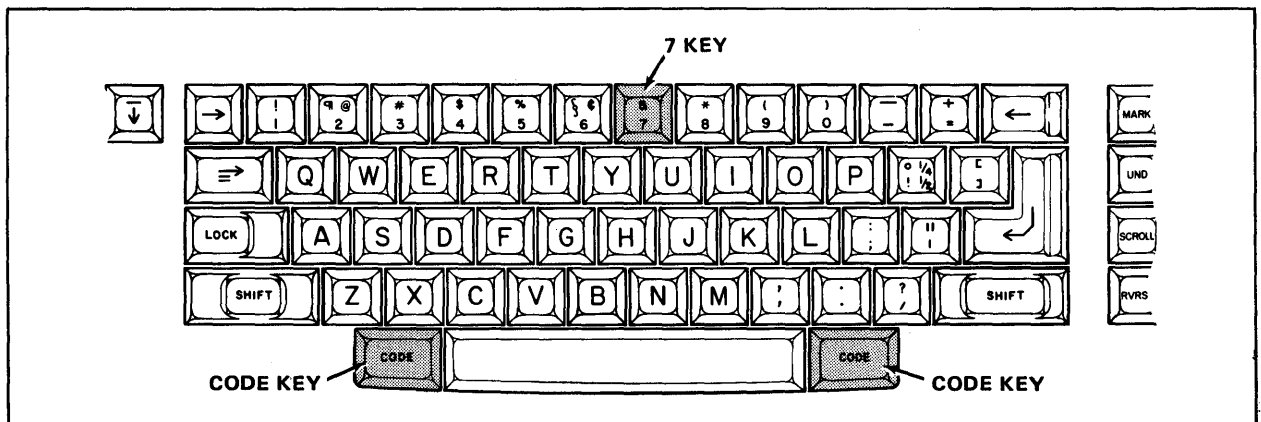

The CODE Keys and the 7 Key
Illustration IV-3

- Step 3** **HOLD** down the CODE key and touch the number 7 key to tell the 860 you want to print the highlighted document.
- Result** The Print Options are brought to the screen in place of the INDEX (see Illustration IV-4 on the next page).
- LOOK** at the Print Options on your screen.

Lesson Four--PRINT I

The Print Options list all the printing options available to you. Later, you'll learn how to select various options. For now, you'll use the options as listed (the standard options).

PRINT OPTIONS

PAGES	1-1
COPIES	1
CONTINUOUS FORM	<input type="checkbox"/>
PAPER SIZE	<input type="checkbox"/>
NON STOP	<input type="checkbox"/>
CODE PRINT	<input type="checkbox"/>
MULTI PASS	<input type="checkbox"/>
PITCH	<input checked="" type="checkbox"/> ANY PS 10 12
KB/PW	<input checked="" type="checkbox"/> ANY STD LEGAL
PRINTWHEEL ID	<input type="checkbox"/>
MERGE	<input type="checkbox"/>
REFORMAT	<input type="checkbox"/>
PAGINATE	<input type="checkbox"/>

*The Print Options Page
Illustration IV-4*

Step 4 TOUCH the ACCPT key to use the standard print options.

Result The print options are removed from the screen and the document is put in the Print List ready to be printed. Later in this lesson, you will learn how to look at the Print List.

Preparing the Printer

The instructions given in Step 5 below are for printers that do not have an Automatic Paper Feeder (APF). If you do have an APF, be sure it has paper in the paper tray and the AUTO MODE light is on. Then go to Step 6 on the next page.

- Step 5** **INSERT** paper in the printer (just as you would in any typewriter). Roll it in until the top edge of the paper is even with the top of the ribbon (see Illustration IV-5 below).

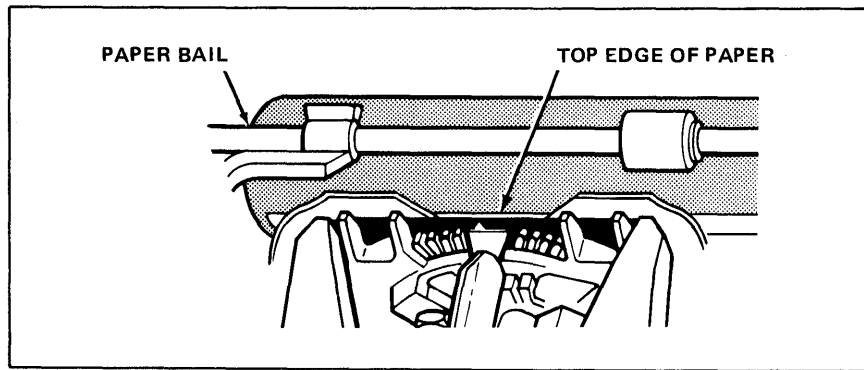

*Positioning the Paper in the Printer
Illustration IV-5*

- PULL** the paper bail away from the platen. Use either of the paper bail levers (see Illustration IV-6 below).

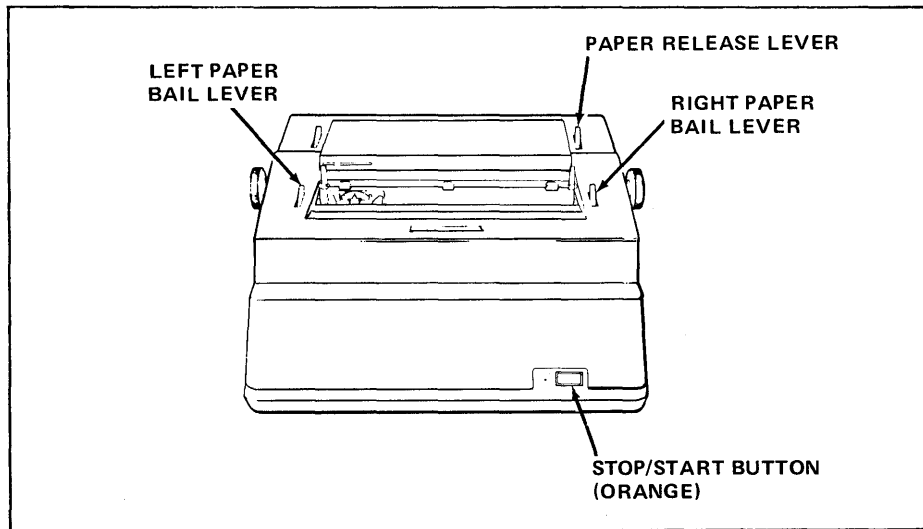

*Position of the Paper Bail Lever and Other Controls on the Standard Printer
Illustration IV-6*

Starting the Printer from the Keyboard

You have already used the PARA key to move from disc to disc. When the PARA key is used with the CODE key, it performs the instruction printed above it (PRINTER START/STOP).

- Step 6**
- | | |
|---------------|--|
| HOLD | down the CODE key and touch the PARA key. |
| Result | The printer immediately begins to print the document. The title of the document is moved from the Print List to the ACTIVE LIST and the USAGE column (on the right side of the ACTIVE LIST) indicates PRINT. |
| LOOK | at your 860's screen and locate the document in the ACTIVE LIST. |

If you don't have an APF:

- | | |
|-------------|---|
| PUSH | the paper bail back in place as the paper rolls upward. |
|-------------|---|

When printing is finished, the title of the printed document is automatically removed from the ACTIVE LIST.

Starting the Printer from the Printer

The Standard Printer has an orange key on the front labeled "START/STOP" (see Illustration IV-6 on the previous page). If your printer has a button, you can use this button instead of CODE + PARA.

PRACTICE EXERCISE

In the practice exercise below, you'll print the document titled **PRINT SECOND**, using the steps given below.

- Step 1** **HIGHLIGHT** the document **PRINT SECOND** (use the LINE key).
- Step 2** **HOLD** down the CODE key and touch the 7 key. The 860 displays the Print Options page.
- TOUCH** ACCPT (to use the standard options).
- Step 3** **INSERT** paper in the printer (if you don't have an APF) and pull back the paper bail.
- Step 4** **HOLD** down the CODE key and touch the PARA key (or use the orange START/STOP button).
- REPLACE** the paper bail (if you don't have an APF).

If you'd like more practice, choose other documents from the INDEX of the Student Disc and print them.

.....

**REVIEW OF
PRINTING ONE DOCUMENT**

This page is a review of the procedures you've learned in this part of the lesson. Read through the procedures to make sure you understand them. Then go on with the lesson.

To select a document for printing:

- INSERT** the System Disc.
- HIGHLIGHT** the document in the INDEX (use LINE key).
- HOLD** down the CODE key and touch the 7 key.
- TOUCH** the ACCPT key to use the standard options.

To prepare the printer (if you don't have an Automatic Paper Feeder):

- INSERT** the paper. Roll the paper far enough up so that the top edge is even with the top of the ribbon.
- PULL** the paper bail towards you.

To start the printer:

- HOLD** down the CODE key and touch the PARA key (or use the orange START/STOP button).
- PUSH** the paper bail back in place as soon as the paper rolls.
- RELEASE** the paper by using the paper release lever.

PRINTING MORE THAN ONE DOCUMENT

You can be typing or making revisions at the same time that documents are printing.

When you select documents for printing, they are put in the Print List until you start the printer. The Print List and the ACTIVE LIST together can hold up to twenty documents. This means if you're working with two documents, you can put up to eighteen other documents into the Print List.

Marking Several Documents for Printing

You can use the MARK key to select several documents for printing.

- Step 1**
- HIGHLIGHT** the document **PRINT FIRST** (use the LINE key).
- TOUCH** the MARK key to tell the 860 you want to select several documents.
- Result** The title **PRINT FIRST** blinks and the MARKED DOCUMENTS counter shows "1".
- HIGHLIGHT** the document **PRINT SECOND**.
- TOUCH** the MARK key.
- HIGHLIGHT** and mark the documents **PRINT THIRD** and **PRINT FOURTH**.
- Result** When you've finished, the four titles should be highlighted and the MARKED DOCUMENTS counter should indicate "4".
- Step 2**
- HOLD** down CODE and touch 7 to tell the 860 to print all of the marked documents.
- TOUCH** the ACCPT key to use the standard print options.
- Result** The documents are put in the Print List and the highlighting is removed from the titles.

Looking at the Print List

The Print List shows all the documents that are waiting to be printed. You can look at the Print List any time you want to see the documents you have selected for printing or to check selected options for a print document.

- Step 4**
- LOOK** at the instruction blocks at the top of the screen. The DISPLAY Print List block has the number 3 over it.
- HOLD** down the CODE key and touch the number 3 key.
- Result** The PRINT LIST replaces the INDEX on the screen (see Illustration IV-7 below). The document titles are shown, along with the disc name and the number of pages.

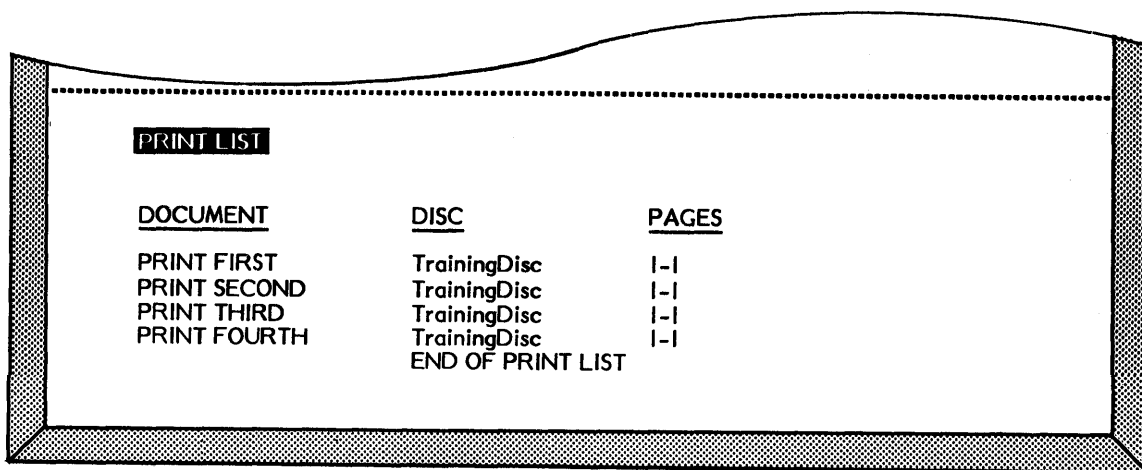

*The Print List Page
Illustration IV-7*

Deleting Documents from the Print List

You can delete documents from the Print List if you decide you do not want them printed. Follow the steps below to delete a document from the Print List.

- Step 5**
- HIGHLIGHT** the document **PRINT THIRD** (use the LINE key).
- TOUCH** the DEL key.
- TOUCH** the ACCPT key.
- Result** The document is deleted from the Print List.

Returning to the Index

After looking at the Print List, you can return to the INDEX by using another instruction block command.

- Step 6**
- LOOK** at the instruction blocks at the top of the screen again. Notice that the DISPLAY INDEX block has the number 2 over it.
- HOLD** down the CODE key and touch the number 2 key.
- Result** The INDEX is returned to the screen.

Printing the Documents

When you start the printer, the documents will print out one after another in the order you selected them. To check the order of documents you can look at the PRINT LIST.

- Step 7**
- INSERT** paper into the printer. Remember, the top edge of the paper should be even with the top of the ribbon.
- HOLD** down the CODE key and touch the PARA key (or use the orange START/STOP button).
- Result** The first document begins printing. It is listed on the ACTIVE LIST and its USAGE column indicates it's at the printer.
- If you have an APF, go to Step 9. If you don't have an APF, after the first document is finished, the Command Line will display:

INSERT PAPER

- Step 8**
- INSERT** another sheet of paper into the printer.
- BEGIN** printing the second document using CODE + PARA or the START/STOP button.
- Result** The printer starts printing and the next document moves to the ACTIVE LIST. Its USAGE is PRINT.

Interrupting The Printer

If you need to interrupt the printer (perhaps the paper is not straight), touch the orange START/STOP button or hold down CODE and touch the PARA key. When you restart the printer, it will print the interrupted page over again from the top.

- Step 9**
- | | |
|---------------|---|
| INSERT | another sheet of paper into the printer. |
| PRINT | the next document. |
| HOLD | down CODE and touch the PARA key to stop printing (or touch the orange START/STOP key). |
| INSERT | a clean sheet of paper into the printer. |
| PRINT | the document again by starting the printer from the keyboard (or the printer). |
| Result | All of the text in the document will print out again. |

.....

**REVIEW OF
PRINTING MORE THAN ONE DOCUMENT**

The next two pages are a review of the procedures you've learned in this part of the lesson. Read through the procedures to make sure you understand them. Then go on with the lesson.

To select several documents for printing:

- HIGHLIGHT** the first document (use the LINE key).
- TOUCH** the MARK key.
- HIGHLIGHT** the next document (use the LINE key or RVRSE and LINE keys).
- TOUCH** the MARK key. Continue until all the documents have been highlighted and marked.
- HOLD** down the CODE key and touch the 7 key.
- TOUCH** the ACCPT key to use the standard print options.

To prepare the printer (if you don't have the Automatic Paper Feeder):

- INSERT** the paper. The top edge should be even with the ribbon.

To start the printer:

- HOLD** down the CODE key and touch the PARA key (or touch the orange START/STOP button on the printer). Wait for the page to be printed.
- REMOVE** the paper (use the paper release lever).
- INSERT** another sheet of paper. Continue until all pages have been printed.

REVIEW — CONTINUED

To interrupt and restart the printer:

HOLD down the CODE key and touch the PARA key (or touch the START/STOP button on the printer).

REMOVE the printed paper (use the paper release lever).

INSERT a new piece of paper.

HOLD down the CODE key and touch the PARA key (or touch the START/STOP button on the printer).



PRINTING AN INDEX

You've seen the INDEX on the screen. You can also print an INDEX. The printed INDEX gives you a quick reference to what is recorded on a disc without having to insert the disc in the system. It is a good idea to keep a printout of the INDEX with your disc when you store it.

Follow the steps below to print an INDEX. (Note: the System Disc must be in the controller in order to print out an INDEX.)

- | | | |
|---------------|---------------|---|
| Step 1 | CHECK | to be sure INDEX: Student Disc is highlighted. |
| Step 2 | INSERT | paper in the printer and pull paper bail back (if you don't have an APF). |
| | LOOK | at the instruction blocks. Notice that the instruction PRINT INDEX has the number 8 over it. |
| Step 3 | HOLD | down the CODE key and touch the 8 key. |
| | Result | The Command Line displays:
<div style="background-color: black; color: white; text-align: center; padding: 5px; margin: 5px 0;">PRINT INDEX?</div> |
| Step 4 | TOUCH | ACCPT to answer "yes". |
| | Result | The printer <u>immediately</u> begins printing the INDEX. (You <u>don't</u> have to touch CODE + PARA.) |

If the INDEX is longer than one page (and you don't have an APF), the 860 will stop and the message INSERT PAPER will appear in the Command Line. When you have done so, start the printer again with CODE + PARA.

DESCRIPTION OF PRINT OPTIONS

This section describes the various print options that are available (see Illustration IV-8 on the next page). In Book One, you will work with the PAGES, COPIES, and CODE PRINT options. You will use the others when you work in Book Two.

- PAGES** You can use this option to print only selected pages of the document. The standard option prints all the pages in a document.
- COPIES** This option allows you to automatically print more than one copy of a document. The standard is one copy.
- CONTINUOUS FORM** This option is selected when you are using continuous form paper. It instructs the 860 to automatically advance the paper between pages and continue printing.
- PAPER SIZE** This option is used if you use paper that is a different length than the PAPER SIZE recorded in the document.
- NON STOP** This option allows you to print a document that contains special codes without acting on the codes.
- CODE PRINT** This option allows you to print the symbols for the codes you record in your documents. (This is especially useful to print all the margins and tabs that you may use with different formats.)
- MULTI PASS** This option allows you to use different type styles (for instance, italicized words or scientific symbols) by changing print wheels.
- MERGE** This option allows you to print repetitive letters. When selected, it will merge a list of names into a standard form letter.

<u>PRINT OPTIONS</u>	
PAGES	1-1
COPIES	1
CONTINUOUS FORM	<input type="checkbox"/>
PAPER SIZE	<input type="checkbox"/>
NON STOP	<input type="checkbox"/>
CODE PRINT	<input type="checkbox"/>
MULTI PASS	<input type="checkbox"/>
PITCH	<input checked="" type="checkbox"/> ANY PS 10 12
KB/PW	<input checked="" type="checkbox"/> ANY STD LEGAL
PRINTWHEEL ID	
MERGE	<input type="checkbox"/>
REFORMAT	<input type="checkbox"/>
PAGINATE	<input type="checkbox"/>

The Print Options Page
Illustration IV-8

You have now completed Lesson Four. On the next pages there are Points to Remember and an Action Summary for you to review.

There is also a Progress Check for you to complete. If you should answer any of the questions incorrectly, turn to the page indicated in the answer and review the information.

POINTS TO REMEMBER

- When you give the print instruction (using CODE + 7), the system gives you options to select how you want the document printed. (Page 4-5)
- The printer can be started by touching the orange START/STOP button on the front of the printer, or by holding down CODE and touching PARA. (Page 4-8)
- The print list and the ACTIVE LIST together can hold up to twenty documents. (Page 4-11)
- When printing with single sheet paper (without an APF), the message INSERT PAPER appears in the Command Line to tell you to insert a new sheet and start the printer again. (Page 4-7)
- You can interrupt the printer (to straighten paper, etc.), by holding down CODE and touching the PARA key (or touching the orange START/STOP button). The printer will begin the page again from the top. (Page 4-14)
- Documents in the Print List are printed in the same order in which they are selected. (Page 4-13)
- You use CODE + 3 to look at the Print List. (Page 4-12)
- You can delete documents from the Print List by using the DEL key. (Page 4-12)
- To return to the INDEX from the Print List, you use CODE + 2. (Page 4-13)

ACTION SUMMARY

You may want to make a copy of this ACTION SUMMARY and keep it on your desk for quick reference.

Documents are selected for printing from the INDEX. They are put in the Print List until you start the printer. If you want to see which documents have been selected for printing, you can look at the Print List.

To print document(s):

- | | | |
|---------------|------------------|---|
| Step 1 | HIGHLIGHT | the INDEX of the disc containing the document, as follows: <ul style="list-style-type: none"> ● Touch PARA to switch from one disc to another ● Touch PAGE to move from ACTIVE LIST to INDEX |
| Step 2 | HIGHLIGHT | the document(s) to be printed, using one of the following methods: <ul style="list-style-type: none"> ● Touch the LINE key to highlight the title OR ● Touch the LINE key to highlight the first title, then touch the MARK key. Continue to use the LINE and MARK keys until all titles are highlighted and marked. |
| Step 3 | HOLD | down CODE and touch the 7 key. |
| | TOUCH | the ACCPT key. |
| Step 4 | INSERT | paper (if you don't have an APF) so the top of the paper is even with the top of the ribbon. |
| | PULL | back the paper bail (you'll push it forward when the printer starts). |
| Step 5 | START | the printer using one of the following methods: <ul style="list-style-type: none"> ● Hold down the CODE key and touch the PARA key OR ● Touch the START/STOP button on the printer. |

ACTION SUMMARY — CONTINUED

To look at the Print List:

- Step 1** **HOLD** down CODE and touch the 3 key.
 LOOK at the documents in the Print List.
- Step 2** **RETURN** to the INDEX by holding down CODE and touching the 2 key.

You can print the INDEX of any disc for a record of what is recorded on the disc.

To print a disc Index:

- Step 1** **INSERT** the System Disc and the disc with the INDEX to be printed.
 INSERT paper in the printer (if you don't have an APF).
- Step 2** **HIGHLIGHT** the INDEX of the disc (touch PARA to switch disc stations).
- Step 3** **HOLD** down CODE and touch the 8 key.

Note: If the INDEX is longer than one page, the 860 will stop printing at the end of the first page. When this happens, insert another sheet of paper, and hold down the CODE key and touch PARA to start the printer.

PROGRESS CHECK

Answer each question by filling in the blank with the correct answer, then compare your answers with those on Page 4-25.

1. The PRINT instruction is given by holding down the _____ key and touching the number _____ key.

2. What are the two methods used to start the printer?
 - a. _____
 - b. _____

3. You can send several documents to the printer at the same time, using the _____ key.

4. You can check which documents are waiting to print by using the _____ and _____ keys to bring the _____ List to the screen.

5. A disc's INDEX can be printed by using the _____ and _____ keys.

6. To move from the PRINT LIST back to the INDEX, use the _____ and _____ keys.

(This page is intentionally left blank.)

ANSWERS TO PROGRESS CHECK

If you are uncertain or answered a question incorrectly, refer to the pages listed on this answer form to review the original material. When you feel comfortable with the material, return to this point in the lesson and continue.

1. The PRINT instruction is given by holding down the CODE key and touching the number 7 key. (Page 4-5)

2. What are the two methods used to start the printer? (Page 4-8)
 - a. CODE + PARA Keys
 - b. START/STOP button on printer

3. You can send several documents to the printer at the same time, using the MARK key. (Page 4-11)

4. You can check which documents are waiting to print by using the CODE and 3 keys to bring the Print List to the screen. (Page 4-12)

5. A disc's INDEX can be printed by using the CODE and 8 keys. (Page 4-17)

6. To move from the PRINT LIST back to the INDEX, use the CODE and 2 keys. (Page 4-13)

(This page is intentionally left blank.)

Xerox 860 IPS Operator Manual
Book One: Fundamentals

Lesson Five – Input I
Typing Documents

LESSON FIVE

INPUT I

Typing Documents

OBJECTIVES

After finishing this lesson, you will be able to:

- type documents using the system's standard format
 - center headings or lines of text
 - underline one word at a time
 - underline a group of words
 - bold one word at a time
 - bold a group of words
 - recall a document that you typed and add new material to the end of it
 - store a revised document in place of the original
-

Materials Needed

For this lesson you will need:

- System Disc
- Student Disc
- Printer and paper
- Reference Manual

BEFORE YOU BEGIN

Check to be sure your 860 is set up as follows:

- System ON.
- **ACTIVITY PAGE** on screen.
- **INDEX: Student Disc** highlighted.

If your 860 is set up correctly, the Activity Page will be displayed on your screen. It should look about like Illustration V-1 below. If your 860 is not turned on or has XEROX on the screen, follow the instructions on page 31 in Lesson One to turn it on and load the software. When the Activity Page is on the screen, insert your Student Disc in the Disc Station. Then return to this page and go on with the lesson.

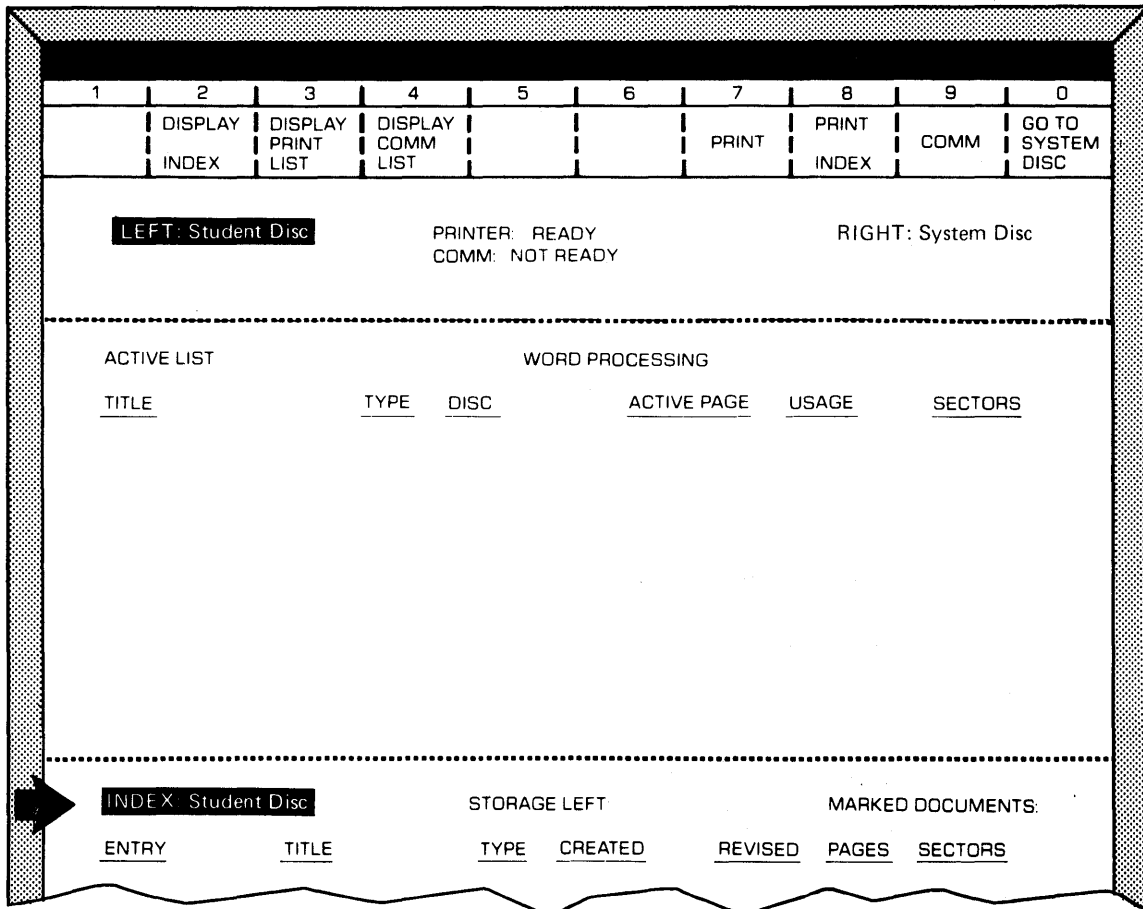



The Activity Page
Illustration V-1

TYPING DOCUMENTS

In Lesson One you typed and stored one short document to become familiar with the keyboard and screen. In this section, you will begin to type longer documents.

Before you can start typing a document, you must give it a title. The title can be up to 20 characters long and must be different from any other title on the disc. The document will be recorded on the disc that is highlighted on the Activity Page.

Creating a New Document

- | | | |
|---------------|--------------|--|
| Step 1 | CHECK | to be sure INDEX: Student Disc is highlighted. (Use the PARA key to switch disc stations if necessary.) |
| | TYPE | TIME as a title for this document. |
| | Result | When you have finished typing the complete title, the Command Line will display the message: ENTER TITLE "TIME" |
| Step 2 | TOUCH | the ACCPT key three times. |
| | Result | <p>The first time you touch the ACCPT key, you tell the system you are finished typing the title.</p> <p>The second ACCPT answers "yes" to the NEW DOCUMENT? message and puts the title on the ACTIVE LIST.</p> <p>The third ACCPT tells the system to bring a blank page to the screen for you to begin typing.</p> |
| | LOOK | at your screen. The Command Line shows you the title of the document, the active PAGE, the LINE number, and the character position. Under the Command Line there is a format block () and a Next Character Mark (). This information on your screen tells you the 860 is ready for you to begin typing the document. |

Typing with Automatic Carrier Return.

To speed up your typing, the 860 automatically returns the carrier for you at the end of a line. There's no need to touch the return key except at the end of short lines or at the end of a paragraph. The 860 senses when the characters are near the right margin and automatically puts in a carrier return for you when you touch the space bar or the hyphen key.

As you type up to the right margin, the 860 will automatically move the last word to the next line if the word would go past the margin. This means that your typing doesn't go past the right margin.

In this exercise, you'll type the document shown in Illustration V-2 below. Follow the step-by-step instructions. They will tell you when to touch the RETURN key and when to let the 860 put in the returns.

- Step 3**
- TYPE** the heading **Productive Time:**
- TOUCH** the RETURN key twice after typing the heading.
- Mistakes?** Simply backspace and retype the correct characters. (You can even backspace carrier returns.)

Productive Time:

This can be divided into two parts, the time spent by the secretary and the time expended by the dictator. The time required for dictation and typing accounts for 55% of the cost of a business letter.

Nonproductive Time:

This time comprises an 8% cost factor. This is the waiting time caused by interruptions during the letter's production or the job time lost due to vacation or illness.

*Text for the Document TIME
Illustration V-2*

Step 4 **TYPE** the first line up to the word **expended** but don't touch the RETURN key. Look at the screen and compare it to Illustration V-3 below.

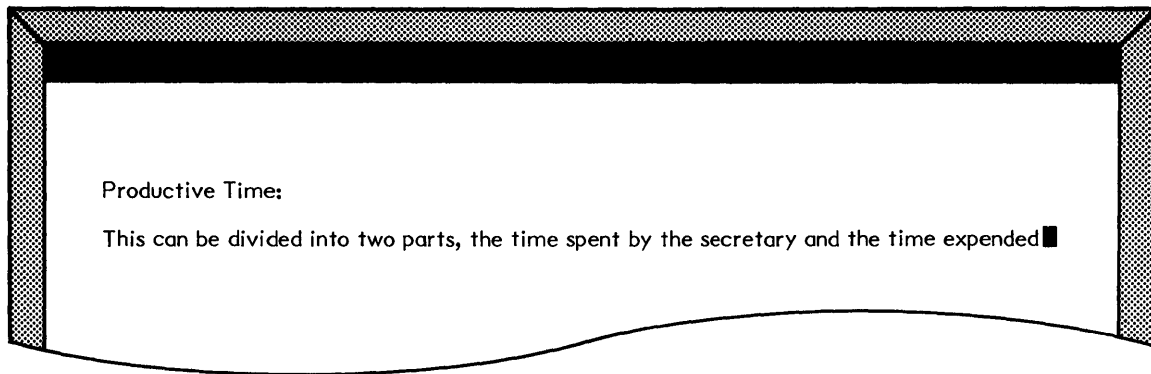

*The Next Character Mark BEFORE an Automatic Carrier Return
Illustration V-3*

TOUCH the SPACE bar once.

Result The word **expended** goes to the next line. The 860 has automatically returned the carrier for you (see Illustration V-4 below).

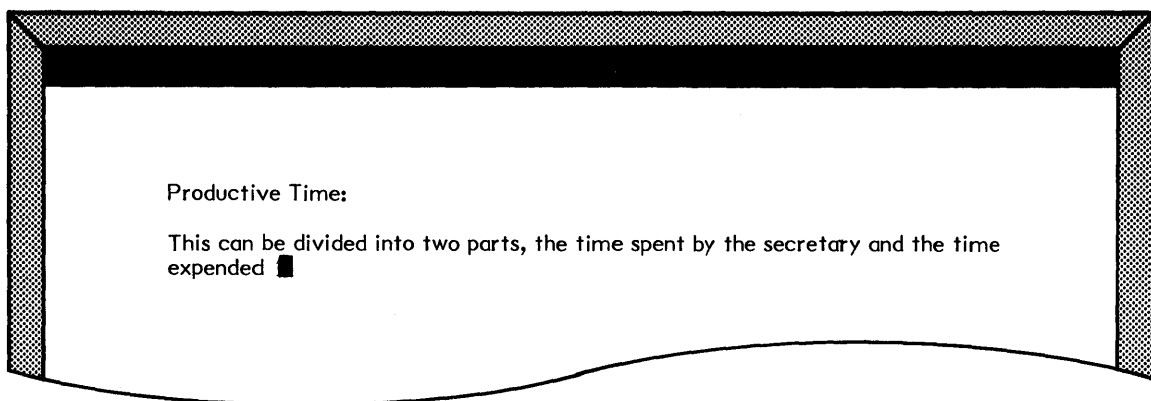

*The Next Character Mark AFTER the First Automatic Carrier Return
Illustration V-4*

Lesson Five--INPUT I

Step 5 **TYPE** the rest of the document. Remember to let the 860 return the carrier for you except at the end of a short line or at the end of a paragraph.

TOUCH the RETURN key once to end the document.

STEP 6 **COMPARE** your work with Illustration V-5 shown below. The copy on your screen should look similar to the illustration.

If you made any mistakes in typing this exercise, don't worry about them now! You will learn how to correct errors in Lesson Six.

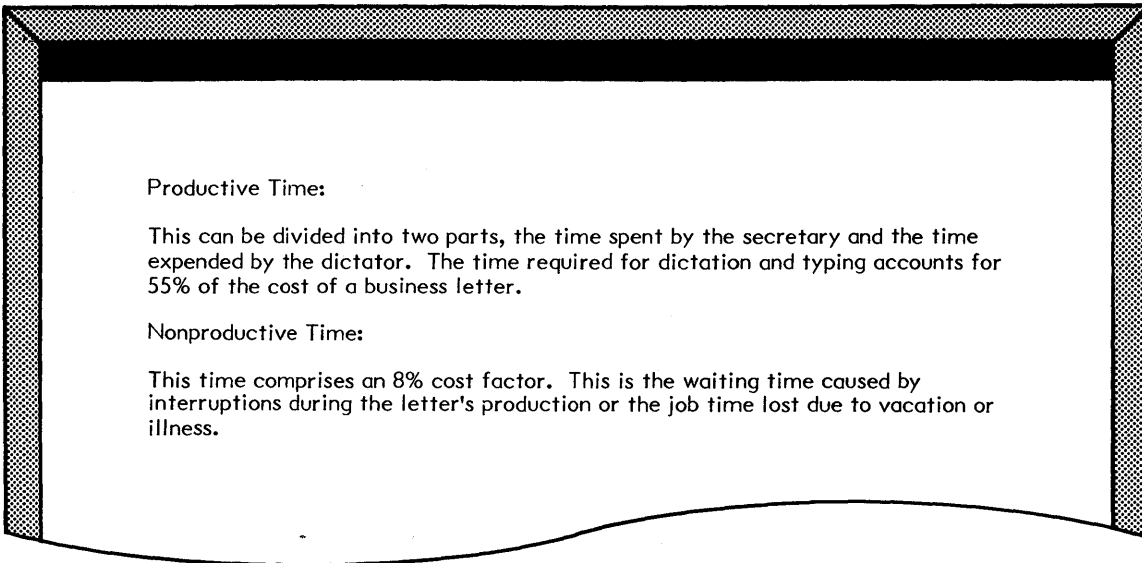

*Corrected Screen Version of Document TIME
Illustration V-5*

Storing the Document

After you type a document, you must store it in the INDEX, so that it will be recorded on the disc.

- Step 7**
- | | |
|--------------|--|
| TOUCH | the STORE key to store this document. |
| Result | The Activity Page is brought to the screen and the Command Line displays STORE DOCUMENT? |
| TOUCH | the ACCPT key to answer "yes". |
| Result | The document title is removed from the ACTIVE LIST and is placed in your INDEX with the next highest entry number. |
| LOOK | at the INDEX on your screen. Notice that the document you just typed is added to the top of the INDEX. |

USING SOME OF THE 860's SPECIAL FEATURES

In the last section, you typed and stored a short document. In this section, you will:

- Create documents using the centering, underlining and/or bolding features of the 860.
- Recall one of the documents to the screen and add new material to the end of it.

CENTERING

Centering is as easy as holding down a button. All you do is hold down the CODE key and touch the 4 key (see Illustration V-6 below). (Notice that the 4 key has the word CENTER over it.) Doing this tells the 860 to center everything you type, up to a carrier return. Remember, it doesn't matter which CODE key you use.

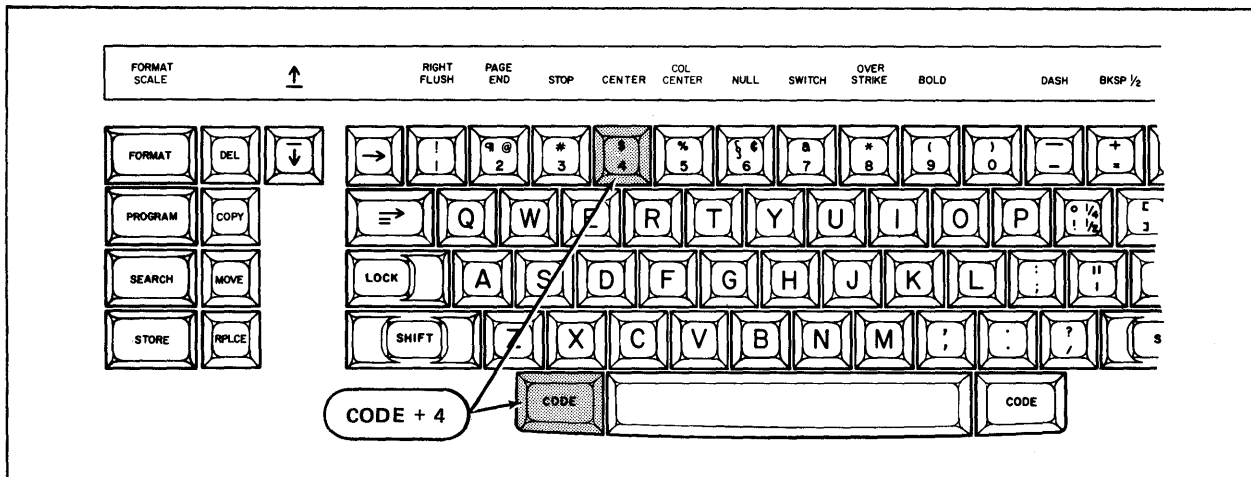

The CODE and 4 Keys Used for Centering
Illustration V-6

Step 1 **TYPE** **CENTERING** for the title of this document.

Step 2 **TOUCH** the ACCPT key three times.

Centering Text

When you want to center a heading or a line, you tell the 860 at the beginning of the line--before you type in the words that are to be centered.

Step 3 **HOLD** down the CODE key and touch the 4 key.

Result The symbol for CODE + 4 (**4**) appears in the middle of the screen. The symbol will remain in front of the words to be centered while you are typing them.

Step 4 **TYPE** the first line **North America**

Result The CODE + 4 symbol and the words **North America** are centered on the line (see Illustration V-7 below).

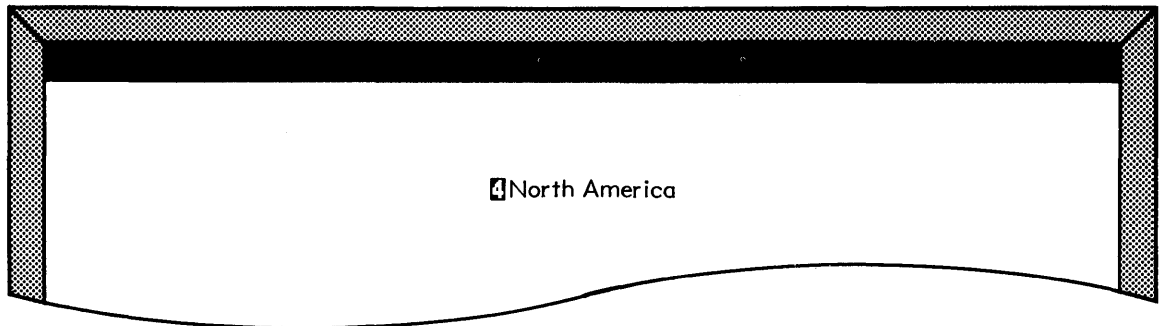

*Screen Display of a Centered Line of Text
Illustration V-7*

TOUCH the RETURN key twice.

Result The words **North America** are centered, the CODE + 4 symbol is no longer displayed.

Lesson Five--INPUT I

Step 5 **HOLD** down the CODE key and touch the 4 key.

Step 6 **TYPE** the second line **United States of America**

TOUCH the RETURN key twice.

Result The second line is centered underneath the first line.

Step 7 **TYPE** the rest of the document, using CODE + 4 to center each line and touching the RETURN key twice after each line (see Illustration V-8 below).

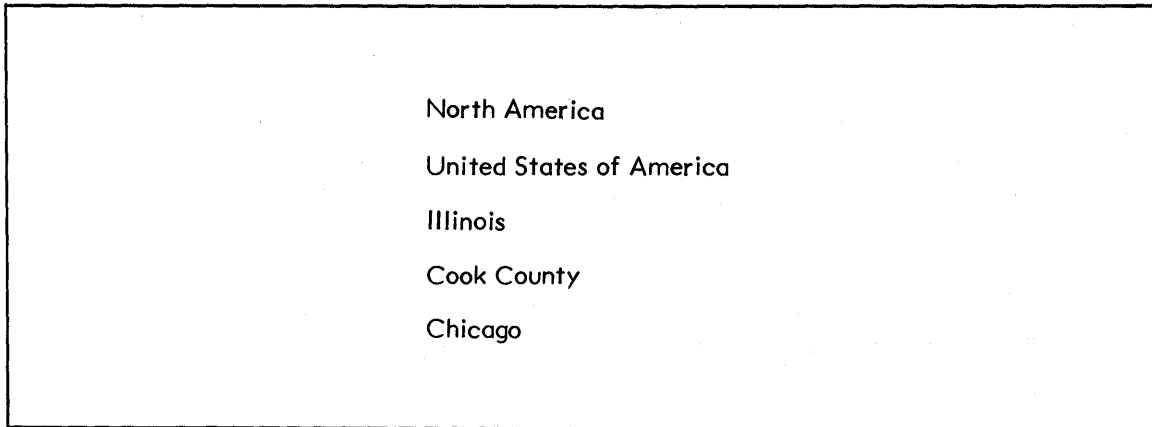

*Text for the Document CENTERING
Illustration V-8*

Step 8 **COMPARE** your work with Illustration V-9 on the next page. Your document should look similar.

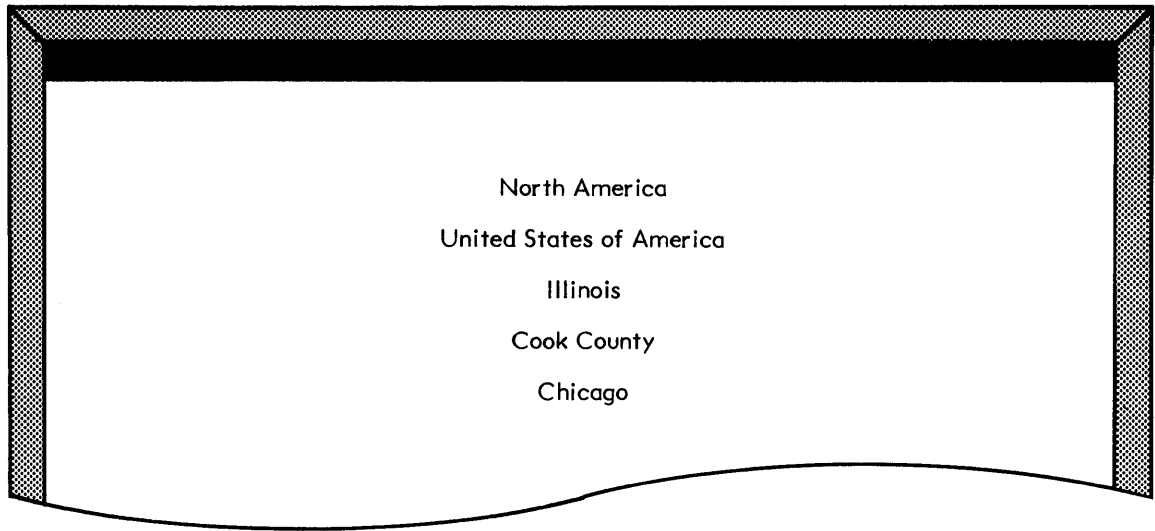

*Screen Version of the Document CENTERING
Illustration V-9*

Now that you've finished typing the document, you need to store it in the INDEX. After the document is stored, you can print it, using the steps below.

- Step 9** **TOUCH** the STORE key.
- TOUCH** the ACCPT key.
- Step 10** **TOUCH** the PAGE key to move the highlighting to the INDEX.
- HIGHLIGHT** **CENTERING** (touch the LINE key).
- HOLD** down the CODE key and touch the 7 key.
- TOUCH** the ACCPT key to use the standard print options.
- INSERT** paper in the printer (if necessary).
- START** the printer from the keyboard (use CODE + PARA).

.....

REVIEW

TYPING A DOCUMENT WITH CENTERING AND AUTOMATIC CARRIER RETURN

This is a review of the procedures you've learned in this part of the lesson. Read through the procedures to make sure you understand them. Then go on with the lesson.

To start a document, you:

CHECK that the proper disc is highlighted.

TYPE the title (up to 20 characters).

TOUCH the ACCPT key three times.

To center a heading or a line of words, you:

HOLD down the CODE key and touch 4.

TYPE the words you want to center.

TOUCH the RETURN key.

To use automatic carrier return, you:

TYPE paragraphs without touching the RETURN key until you reach the end.

TOUCH the RETURN key only at the end of short lines, or at the end of a paragraph.

To store a document, you:

TOUCH the STORE key.

TOUCH the ACCPT key.

.....

PRACTICE EXERCISE

In the practice exercise below, you'll create a short document with a centered heading and a paragraph of text. When you type the paragraph, remember to let the 860 put in the carrier returns. You'll only need to touch the RETURN key after the heading and at the end of the paragraph.

- Step 1** **TITLE** a document **MORE CENTERING** and bring it to the screen, using the following steps:
- Type **MORE CENTERING**
 - Touch **ACCPT** three times
- Step 2** **CENTER** the heading, using the following steps:
- Hold down **CODE** and touch **4**
 - Type the heading
 - Touch **RETURN** twice
- Step 3** **TYPE** the paragraph of text, remembering not to touch the **RETURN** key until you reach the end of the paragraph.

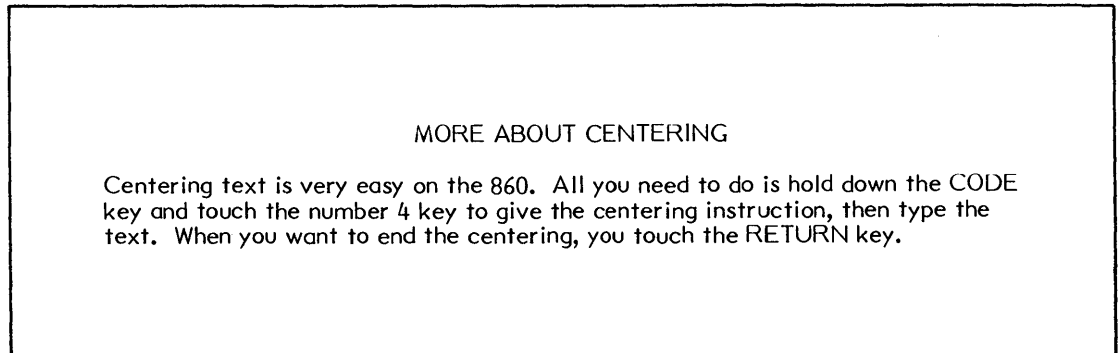

*Text for the Document **MORE CENTERING**
Illustration V-10*

- Step 4** **COMPARE** the document on the screen with the illustration above. It should look similar.
- Step 5** **STORE** the document by touching **STORE** and **ACCPT**.

UNDERLINING

Underlining is very easy on your 860. To underline one word at a time, type the word (but don't space), then touch the UND (Underline) key (see Illustration V-12 below).

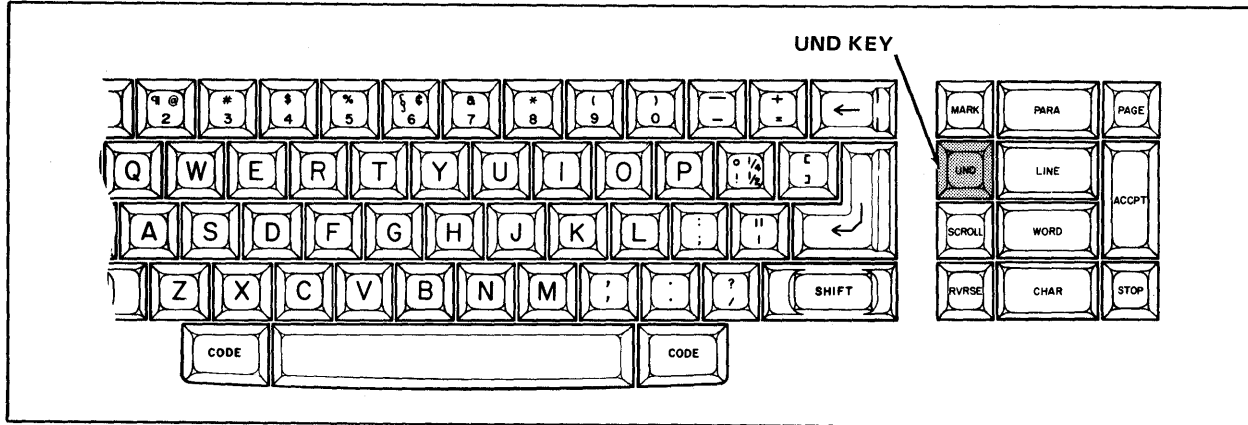

The UND (Underline) Key
Illustration V-12

- Step 1** **TITLE** this new document **ALPS**
- TOUCH** the ACCPT key three times.
- Step 2** **CENTER** the heading using the following steps:
- Hold down CODE, touch 4
 - Type the heading
 - Touch RETURN twice
- TYPE** the first word in the paragraph: **The**

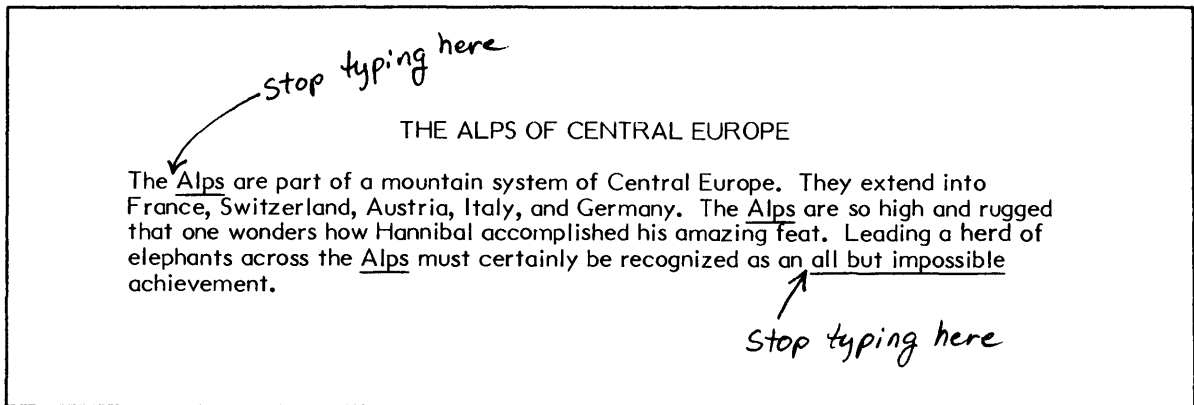

Text for the Document **ALPS**
Illustration V-13

Underlining Single Words

- Step 3**
- | | |
|---------------|--|
| TYPE | the word Alps (do not space after it). |
| TOUCH | the UND (Underline) key. (If you accidentally spaced after the word, touch UND, backspace and then touch the UND key again.) |
| Result | The word Alps is underlined. |
| LOOK | at the underlined word Alps on your screen. |
| TOUCH | the SPACE bar (to add the necessary space after the word). |
- Step 4**
- | | |
|-------------|--|
| TYPE | more of the document, underlining as indicated. Stop typing at the space before the words all but impossible . Then turn to the instructions on the next page. (Remember to let the 860 return the carrier within the paragraph.) |
|-------------|--|

Continuous Underlining

To underline several words in a row (continuous underlining), you touch the UND key, type the words to be underlined, and then touch the UND key again. In other words, you turn on underline, type in the text, and turn off underline.

- Step 5 TOUCH** the UND key.
- Result** The Command Line displays the words **UND BOLD OVER** and the word **UND** is highlighted (black letters on a white background).
- LOOK** at the Command Line to find the **UND BOLD OVER** message.
- TYPE** the three underlined words **all but impossible**.
- Result** Each letter is underlined on the screen as you type it. The **UND** message remains in the Command Line as long as you are underlining.
- TOUCH** the UND key to turn off the continuous underlining.
- TYPE** the remainder of the document (shown below).

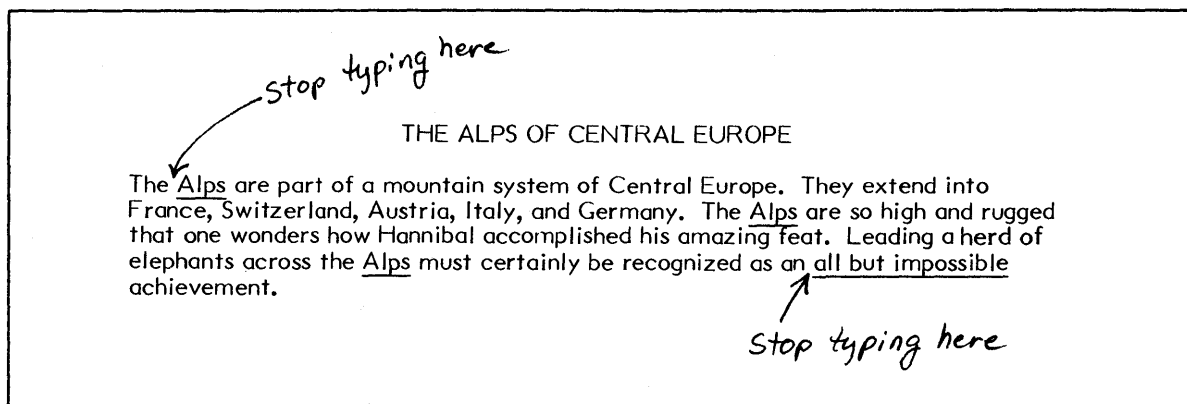

Text for the Document **ALPS**
Illustration V-13

When you're finished with the document, you'll need to store it in the INDEX.

Step 6 **STORE** the document by touching STORE and ACCPT.

You'll recall this document later in this lesson and add text to the end of it.

PRACTICE EXERCISE

In the practice exercise below, you'll type a short document. You'll use all the features that you've learned so far: centering the heading, underlining words, and letting the 860 return the carrier within the paragraphs.

- Step 1** **TITLE** a document **UNDERLINING** and bring it to the screen, using the following steps:
- Type **UNDERLINING**
 - Touch **ACCPT** three times
- Step 2** **CENTER** the heading, using the following steps:
- Hold down **CODE** and touch **4**
 - Type the heading
 - Touch **RETURN** twice
- Step 3** **TYPE** the text, using the following steps:
- Underline a single word by typing the word, then touching **UND**
 - Underline several words by touching **UND**, typing the words, and touching **UND** again
 - Touch the **RETURN** key only at the end of paragraphs

UNDERLINING

Underlining is a feature of the 860 that saves you time and effort; you can underline any amount of information with a single instruction.

You can underline several words in a row by touching the **UND** key, typing the words you want to underline and touching the **UND** key again. You tell the system to begin underlining, type the words, and tell the system to stop underlining.

*Text for the Document **UNDERLINING**
Illustration V-14*

- Step 4** **STORE** the document by touching STORE and ACCPT.
- Step 5** **PRINT** the document, using the following steps:
- Touch PAGE to highlight INDEX of your Student Disc
 - Highlight the document **UNDERLINING**
 - Hold down CODE and touch 7
 - Touch ACCPT
 - Insert paper and start the printer
- Step 6** **COMPARE** your printed document to Illustration V-15 below.

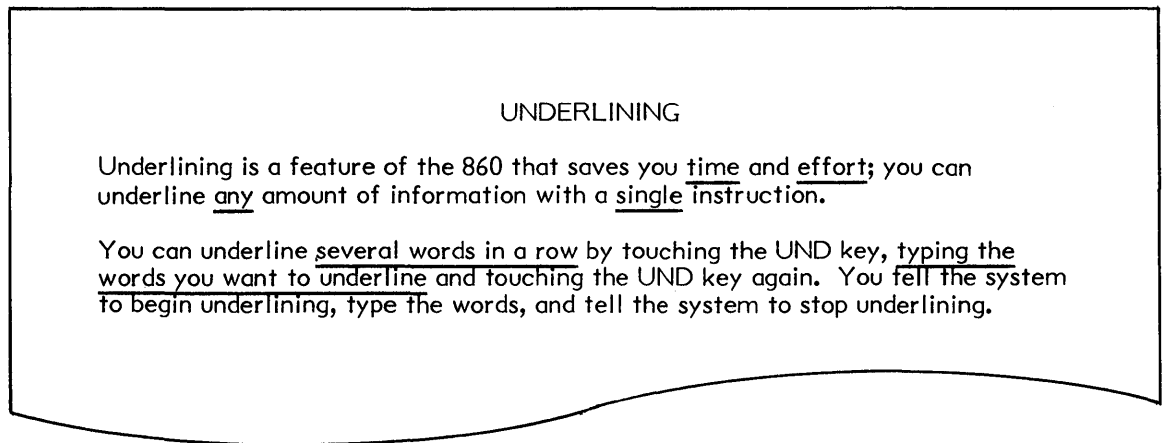

*Printed Version of the Document **UNDERLINING**
Illustration V-15*

BOLDING

Instead of using italics or underlines to emphasize words in a document, you can use an 860 feature called BOLD. For example, the title above this paragraph is bolded. When the 860 bolds a word, it prints each character twice. To make each character appear wider and darker, the second printing is just a fraction of an inch to the right.

The steps to bold are similar to underline. Instead of the UND key, you use the CODE and the 9 keys (see Illustration V-18 below). Notice the word BOLD over the 9 key on the Keyboard.

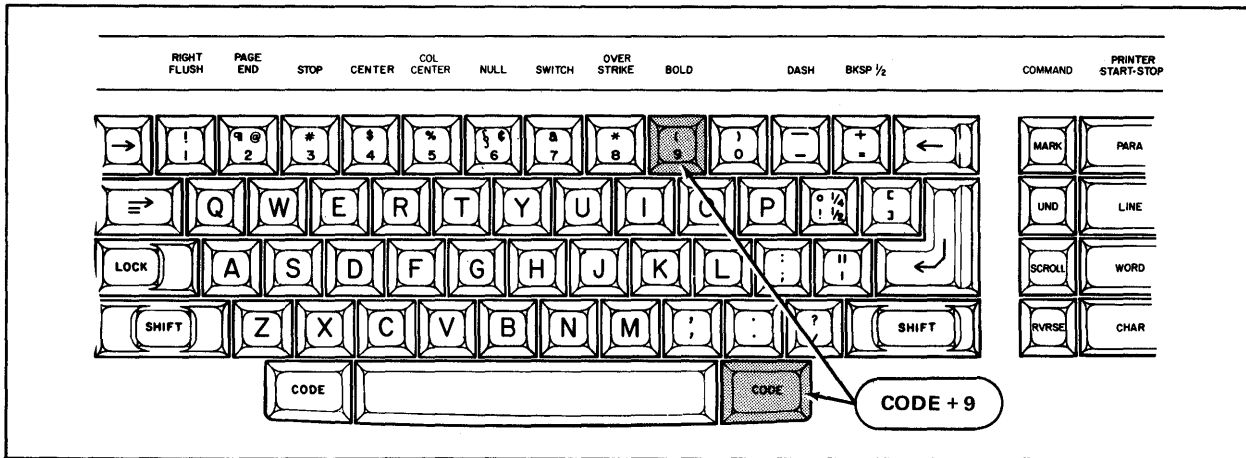

The CODE and 9 Keys (Used for Bolding)
Illustration V-18

Step 1 **TITLE** this document **BOLDING**

TOUCH the ACCPT key three times.

Bolding Single Words

The document you'll type is shown in Illustration V-19 on the next page. To bold a word, you type the word then touch CODE + 9. (CODE + 9 means you hold down the CODE key and touch the 9 key.) Follow the step-by-step instructions to type the document.

Step 2 **HOLD** down the CODE key and touch 4 to center the heading.

TYPE the word **BOLDING** but don't space after it.

HOLD down CODE and touch 9.

Result The word **BOLDING** is underlined in the display.

Bolded and underlined words are both underlined on the screen. To tell the bolded words from underlined words, you highlight a character in the word using the CHAR key and then check the message in the Command Line. Try this now.

- Step 3**
- HOLD** down RVRSE and touch CHAR two times.
- Result** The Next Character Mark is replaced by an End of Document Mark.
- The first time you touch the CHAR key, the End of Document Mark is highlighted.
- The second time you touch the CHAR key, the "G" in BOLDING is highlighted and the Command Line displays UND BOLD OVER with BOLD highlighted (black letters on white background).

To continue typing at the end of the document, you need to bring the Next Character Mark back to the screen. Holding down CODE and touching ACCPT will replace the End of Document symbol with the Next Character Mark.

HOLD down CODE and touch ACCPT to bring back the Next Character Mark.

Result The Next Character Mark is brought back to the screen, exactly where the typing ended on the page.

TOUCH the RETURN key twice.

Step 4 **TYPE** the first paragraph (see Illustration V-19 below).

Remember Use CODE + 9 after a word to bold it.

TOUCH the RETURN key twice at the end of the first paragraph.

BOLDING

Words may be bolded during input or during an edit. To bold one word during input: type the word, use CODE + 9, then type the space after the word. If you want to bold several words in a row, use CODE + 9, type the words, then use CODE + 9 again.

*Text for the Document BOLDING
Illustration V-19*

Bolding a Group of Words

To bold a group of words, you use CODE + 9 to turn on bold, type the words and then use CODE + 9 to turn off bold (just as you did with underline). Use the following steps to type the paragraph shown in Illustration V-20 below.

- Step 5**
- HOLD** down CODE and touch 9 to turn on the BOLD feature.
- TYPE** **To bold during an edit:**
- Result** The words appear underlined on the screen as you type them. And the message **UND BOLD OVER** is displayed in the Command Line.
- HOLD** down CODE and touch 9 again to turn off the BOLD feature.
- TYPE** the rest of the document.

To bold during an edit; highlight the word and use CODE + 9. If there are several words in a row to be bolded, use the text keys and MARK to highlight the words, then use CODE + 9.

*Text for the Document **BOLDING**
Illustration V-20*

- Step 6** **STORE** the document (touch STORE and ACCPT).
- Step 7** **PRINT** the document.
- Step 8** **COMPARE** your printed copy to Illustration V-21 below.

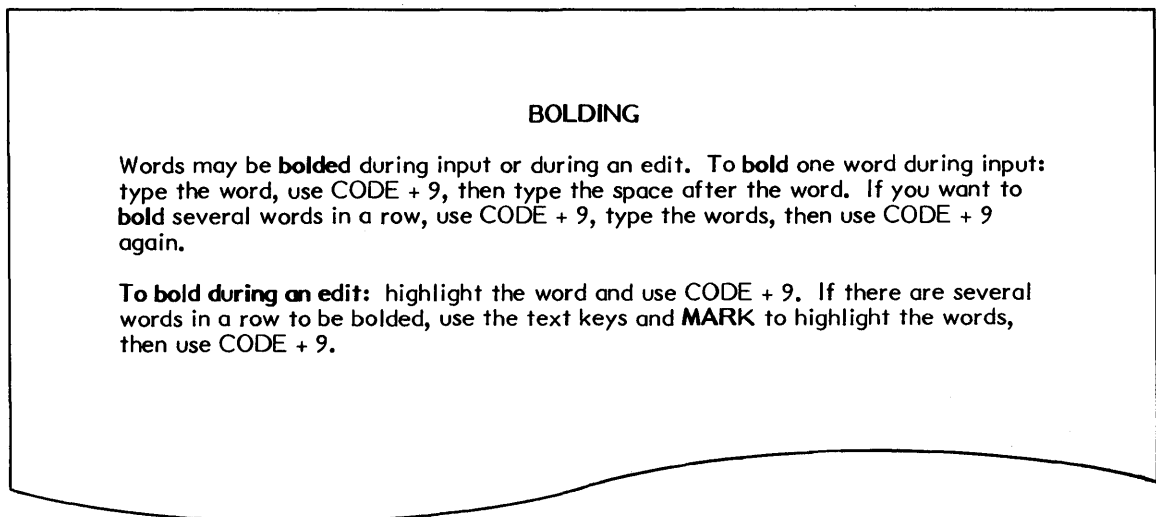

*Printed Version of the Document **BOLDING**
Illustration V-21*

You'll be using a combination of bolding and underlining in other exercises. Remember, both features are indicated by underlining on the screen. To tell which feature you used, you can highlight one character in the text, (using CHAR) and check the message in the Command Line.

.....

**REVIEW OF
UNDERLINING AND BOLDING**

This page is a review of the procedures you've learned in this part of the lesson. Read through the procedures to make sure you understand them. Then go on with the lesson.

The following points refer to underlining and bolding that you do when you are typing the material for the first time. If you need to underline or bold after you have typed a document, the procedure will be slightly different. This will be discussed in a later lesson. (CODE + 9 means hold down the CODE key while you touch the 9 key.)

To underline one word at a time:

- TYPE** the word to be underlined (don't space after the word).
- TOUCH** **UND.**

To underline several words in a row:

- TOUCH** **UND** before the first word to be underlined.
- TYPE** the words to be underlined.
- TOUCH** **UND** after the last letter of the last word to be underlined.

To **bold** one word at a time:

- TYPE** the word to be bolded (don't space after the word).
- TOUCH** **CODE + 9.**

To **bold** several words in a row:

- TOUCH** **CODE + 9** before the first word to be bolded.
 - TYPE** the words to be bolded.
 - TOUCH** **CODE + 9** right after the last word to be bolded.
-

ADDING TO THE END OF A DOCUMENT

Sometimes you may want to store a document before finishing it. Maybe you're interrupted by a priority job or it's lunch time. When you're ready to finish typing the document, you simply recall it and use CODE + ACCPT to put the Next Character Mark at the end of the page. Follow the steps below to do this:

- Step 1** **RECALL** the document you typed earlier titled **ALPS**, using the following steps:
- Touch PAGE to highlight the INDEX of your Student Disc
 - Use LINE to highlight the title
 - Touch the ACCPT key twice
- Step 2** **HOLD** down the CODE key and touch the ACCPT key.
- Result The Next Character Mark is brought back to the screen, exactly where the typing ended on that page.

Typing Additional Text

- Step 3** **TYPE** the additional paragraph (shown below in Illustration V-22). Use the UND key to underline. Be sure to end the paragraph with a return.

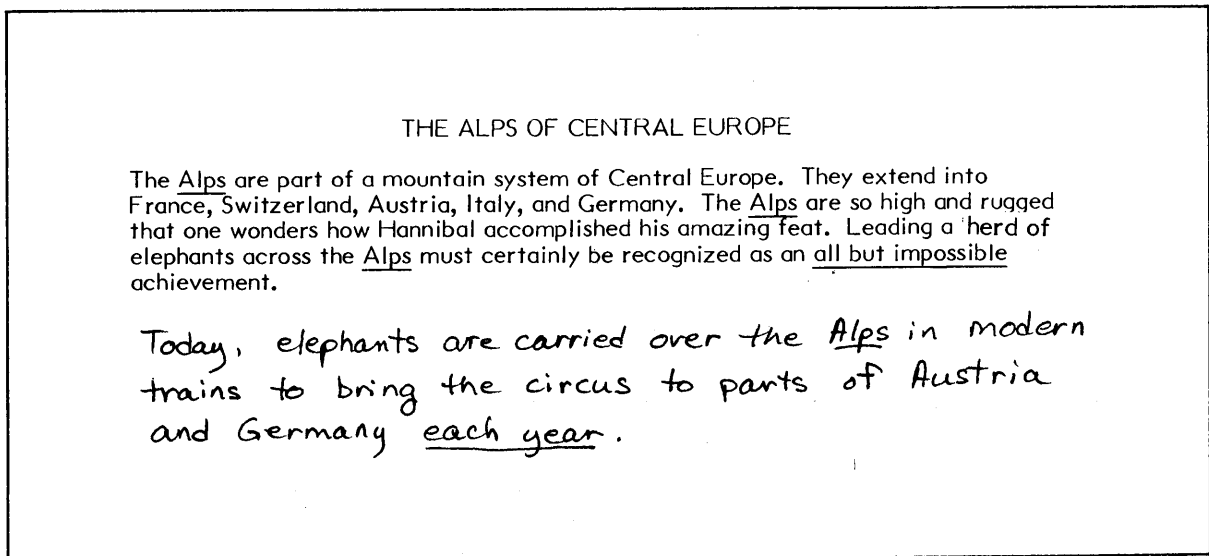

*Additional Text for the Document ALPS
Illustration V-22*

Storing a Revised Document

Anytime you recall a document, the original stays on the disc. When you make changes, the 860 considers it a revision. The 860 will then ask you what you want to do with the document. You have three choices:

- (1) Save only the **revised** document.
- (2) Save both the **revised** and the **original** documents.
- (3) Save only the **original** document.

In the steps below, you'll save only the revised document by storing it over (in place of) the original.

- Step 3** **TOUCH** the STORE key.
- Result The Activity Page returns to the screen. ALPS is in the ACTIVE LIST and the Command Line displays STORE DOCUMENT?
- TOUCH** ACCPT to answer "yes".
- Result The Command Line displays
- STORE OVER ORIGINAL?**
- The system is asking if you want to store the revised version of the document in place of the original. In this case, you do want to store over the original.
- TOUCH** the ACCPT key.
- Result The revised document is removed from the ACTIVE LIST and is stored on the disc under the original title. Since it is a revised document, it will have the highest entry number on the INDEX.
- LOOK** at the INDEX of your Student Disc. Notice that the document ALPS has been stored at the top of the INDEX, and that it has a date in the REVISED column, indicating that it has been revised.
- The original version of the document has been placed on the Backup Index. You'll learn to use the Backup Index in Lesson Eight on the System Utilities.

Step 4 **PRINT** the document.

Step 5 **COMPARE** your printed copy to Illustration V-23 below. Yours should look similar.

THE ALPS OF CENTRAL EUROPE

The Alps are part of a mountain system of Central Europe. They extend into France, Switzerland, Austria, Italy, and Germany. The Alps are so high and rugged that one wonders how Hannibal accomplished his amazing feat. Leading a herd of elephants across the Alps must certainly be recognized as an all but impossible achievement.

Today, elephants are carried over the Alps in modern trains to bring the circus to parts of Austria and Germany each year.

*Print version of the revised document ALPS
Illustration V-23*

Lesson Five--INPUT I

You have now completed Lesson Five. On the next pages there are Points to Remember and an Action Summary for you to review.

There is also a Progress Check for you to complete. If you should answer any of the questions incorrectly, turn to the page indicated in the answer and review the information.

POINTS TO REMEMBER

- Every document must have a format block at the beginning of each page.
- When typing paragraphs of text, let the 860 return the carrier within the paragraph and touch the RETURN key only at the end of a paragraph or short line. (Page 5-5)
- CODE + 4 tells the system to automatically center everything you type up to a carrier return. (Page 5-8)
- To underline one word at a time, type the word (don't space), then touch UND. (Page 5-15)
- To underline several words in a row, touch the UND key to turn on continuous underlining, type the words to be underlined, then touch the UND key again to turn underlining off. (Page 5-16)
- To bold one word at a time, type the word (don't space), then hold down CODE and touch 9. (Page 5-20)
- To bold several words in a row, hold down CODE and touch 9 to turn on the bolding, type the words to be bolded, then hold down CODE and touch 9 to turn bolding off. (Page 5-22)
- To find out if text is underlined or bolded, highlight one character in the text and check the message (UND BOLD OVER) in the Command Line. (Page 5-21)
- Holding down the CODE key and touching ACCPT will restore the Next Character Mark on the page that is currently displayed. (Page 5-25)
- You can make any of the following three choices when storing a revised document (Page 5-26):
 - a. Save only the revised document.
 - b. Save both the revised and original document.
 - c. Save the original and clear the revisions.

ACTION SUMMARY

You may want to make a copy of this ACTION SUMMARY and keep it on your desk for quick reference.

When you begin a new document, first you must select the disc that you want the document to be stored on and type a title for the document. After you type the text, you must store the document on the disc.

To create a new document:

- Step 1** **SELECT** the disc that you want the document stored on. (Check the status line near the top of the Activity Page, and use the PARA key to switch disc stations.)
- Step 2** **TYPE** a title for the document.
- TOUCH** the ACCPT key three times.
- Step 3** **TYPE** the text in the document, using Automatic Carrier Return as follows:
- Let the 860 return the carrier in the middle of paragraphs
 - Touch the return key only at the end of paragraphs and short lines
- CENTER** text using the following steps:
- Hold down CODE and touch the 4 key
 - Type the text to be centered
 - Touch return
- UNDERLINE** text using one of the following methods:
- Type the word and touch the UND key
- OR
- Touch the UND key, type the words and touch the UND key again
- BOLD** text using one of the following methods:
- Type the word, hold down CODE and touch the 9 key
- OR
- Hold down CODE and touch the 9 key, type the words, and hold down CODE and touch the 9 key again
- END** the document with a carrier return.
- Step 4** **STORE** the document using the following steps:
- Touch the STORE key
 - Touch the ACCPT key

ACTION SUMMARY -- CONTINUED

After a document has been typed, you can recall it and add more text. When you do this, you must store it again.

To recall a document and add text to it:

- | | | |
|---------------|------------------|---|
| Step 1 | HIGHLIGHT | the INDEX of the disc containing the document, as follows: <ul style="list-style-type: none">● Touch PARA to switch from one disc to another● Touch PAGE to move from ACTIVE LIST to INDEX |
| Step 2 | RECALL | the document to the screen using the following steps: <ul style="list-style-type: none">● Touch LINE to highlight the title● Touch ACCPT twice |
| Step 3 | HOLD | down the CODE key and touch ACCPT. |
| | TYPE | the additional text. |
| | END | the document with a carrier return. |
| Step 4 | STORE | the document using the following steps: <ul style="list-style-type: none">● Touch STORE● Touch ACCPT <u>twice</u> |

PROGRESS CHECK FOR LESSON FIVE

Part I

In this Progress Check exercise, you will create a document using centering, underlining, and bolding. Then you'll recall the document and add to it, store the revision over the original and print it.

1. Create a document called **PROGRESS I** on your Student Disc.
2. Type the heading and the first paragraph (see Illustration V-24 below). The wavy lines (~~~~) show which words to **BOLD** and the straight lines (——) show which words to UNDERLINE.
3. Store the document.
4. Recall the document.
5. Add the last paragraph to the document.
6. Store the revised version of the document over the original.
7. Print your document when finished.
8. Check your printed copy against the version in Illustration V-25 on the next page.

DISTINCTIVE TYPES

To most people, type faces look alike; even experts must look carefully to differentiate between them.

The entire appearance of a printed piece can be altered by the selection of type faces. Many characteristics, masculinity, femininity, delicacy, formality, etc., can be suggested by the type face used.

*Text for the Document **PROGRESS I**
Illustration V-24*

DISTINCTIVE TYPES

To **most** people, type faces look alike; even experts must look carefully to differentiate between them.

The **entire appearance** of a printed piece can be altered by the selection of type faces. Many characteristics, masculinity, femininity, delicacy, formality, etc., can be suggested by the type face used.

*Print Version of the Document **PROGRESS I**
Illustration V-25*

(This page is intentionally left blank.)

PROGRESS CHECK -- CONTINUED

Part II

Answer each question by filling in the blank with the correct answer, then compare your answers with those on Page 5 - 37.

1. In order to add more information to the end of a document, or to quickly get to the end of your typing, you can restore the Next Character Mark by holding down the CODE key and touching _____.

2. When you want a single word to be underlined, you first _____
_____. Then you touch _____.

3. To center a line of text or a heading, you:

4. To bold a series of words in a row, you:

5. You have three choices when storing a document that has been revised:
 - a. Save only the _____ document.
 - b. Save both the _____ and the _____ documents.
 - c. Save only the _____ document.

(This page is intentionally left blank.)

ANSWERS TO PROGRESS CHECK (PART II)

If you are uncertain or answered a question incorrectly, refer to the pages listed on this answer form to review the original material. When you feel comfortable with the material, return to this point in the lesson and continue.

1. In order to add more information to the end of a document, or to quickly get to the end of your typing, you can restore the Next Character Mark by holding down the CODE key and touching ACCPT. (Page 5-25)

2. When you want a single word to be underlined, you first type
the word. Then you touch UND.
(Page 5-15)

3. To center a line of text or a heading, you:
Use the CODE + 4 keys
(Page 5-8)

4. To bold a series of words in a row, you:
USE CODE + 9 to turn on bold, type the
words, use CODE + 9 to turn off bold
(Page 5-22)

5. You have three choices when storing a document that has been revised (Page 5-26):
 - a. Save only the revised document.
 - b. Save both the revised and the original documents.
 - c. Save only the original document.

Lesson Five--INPUT I

(This page is intentionally left blank.)

Xerox 860 IPS Operator Manual
Book One: Fundamentals

Lesson Six – Edit I
Making Revisions

LESSON SIX

EDIT I

Making Revisions

OBJECTIVES

After finishing this lesson, you will be able to:

- highlight part or all of a page of text
 - use the CAT (if you have one)
 - add and delete underlining and bolding to existing text
 - delete text
 - insert new text
 - use search to locate text
 - replace old text with new text
 - change text to upper or lower case
 - store a revised document under a new title
-

Materials Needed

For this lesson you will need:

- System Disc
- Student Disc
- Printer and Paper
- Reference Manual

PRELIMINARY ACTIVITIES

Make sure the 860 System is ready for typing:

- System ON.
- Student Disc in left disc station.
- System Disc in right disc station.
- Activity Page displayed.
- **INDEX: Student Disc** highlighted.

If your 860 is set up correctly, the screen should look like Illustration VI-1 below.

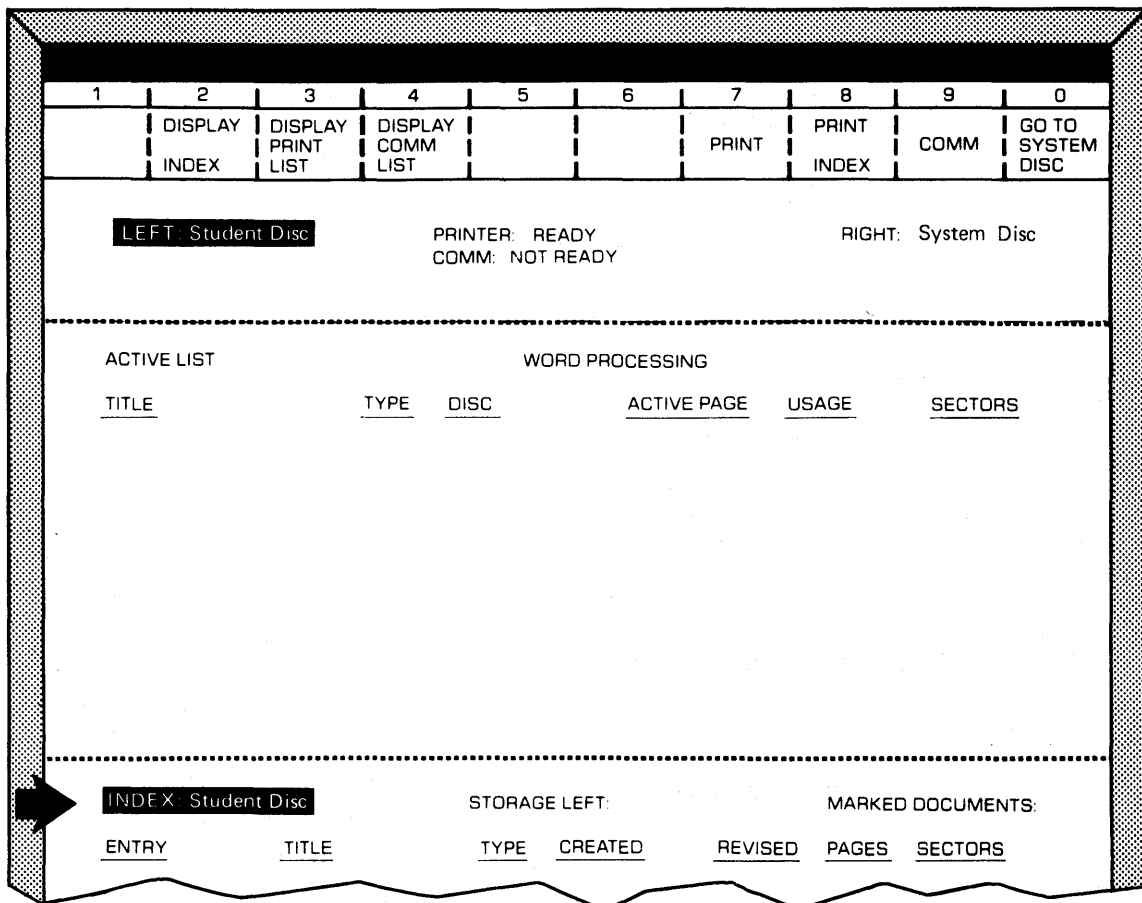

The Activity Page
Illustration VI-1

HIGHLIGHTING

You highlight text in order to tell the 860 that you will do something with the highlighted area. In the next exercises you will practice highlighting text in the document titled SOURCES.

Step 1 **RECALL** the document titled **SOURCES** (use **LINE** to highlight the tile and touch **ACCP** twice.)

Result The document is displayed on the screen.

Looking at the Symbols on a Page

By highlighting an entire page, you can look at the document as the system sees it, complete with carrier returns and format block. To do this, you use the **CODE** key and the **PAGE** key (see Illustration VI-2 below). When you hold down the **CODE** key and touch the **PAGE** key, all codes are displayed and the text is highlighted.

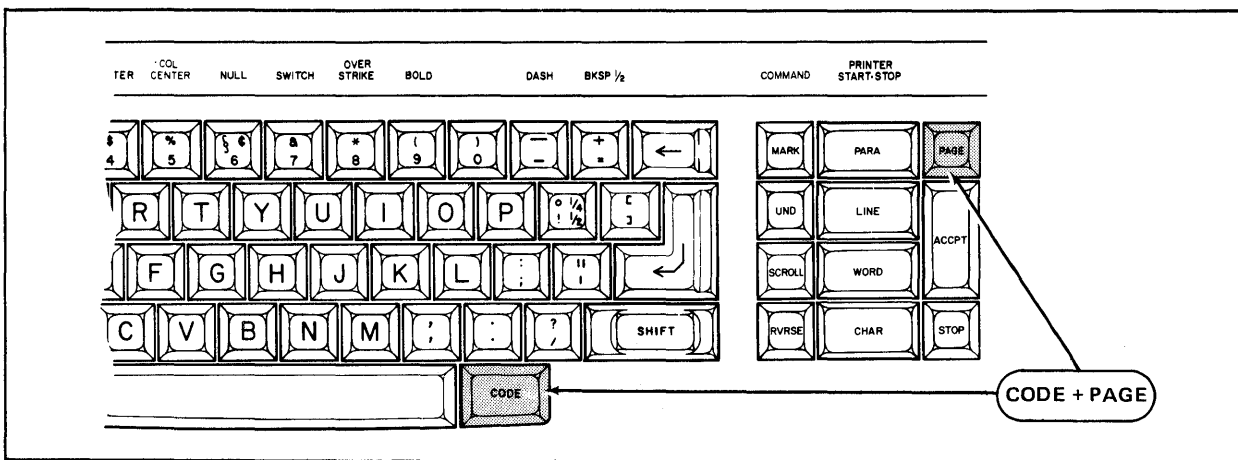

The **CODE** and **PAGE** Keys
Illustration VI-2

Step 2 **HOLD** down the CODE key and touch the PAGE key.

Result The text is highlighted (white letters on black). The carrier returns, the format block and the end of document mark also show on the screen. (see Illustration VI-3 below).

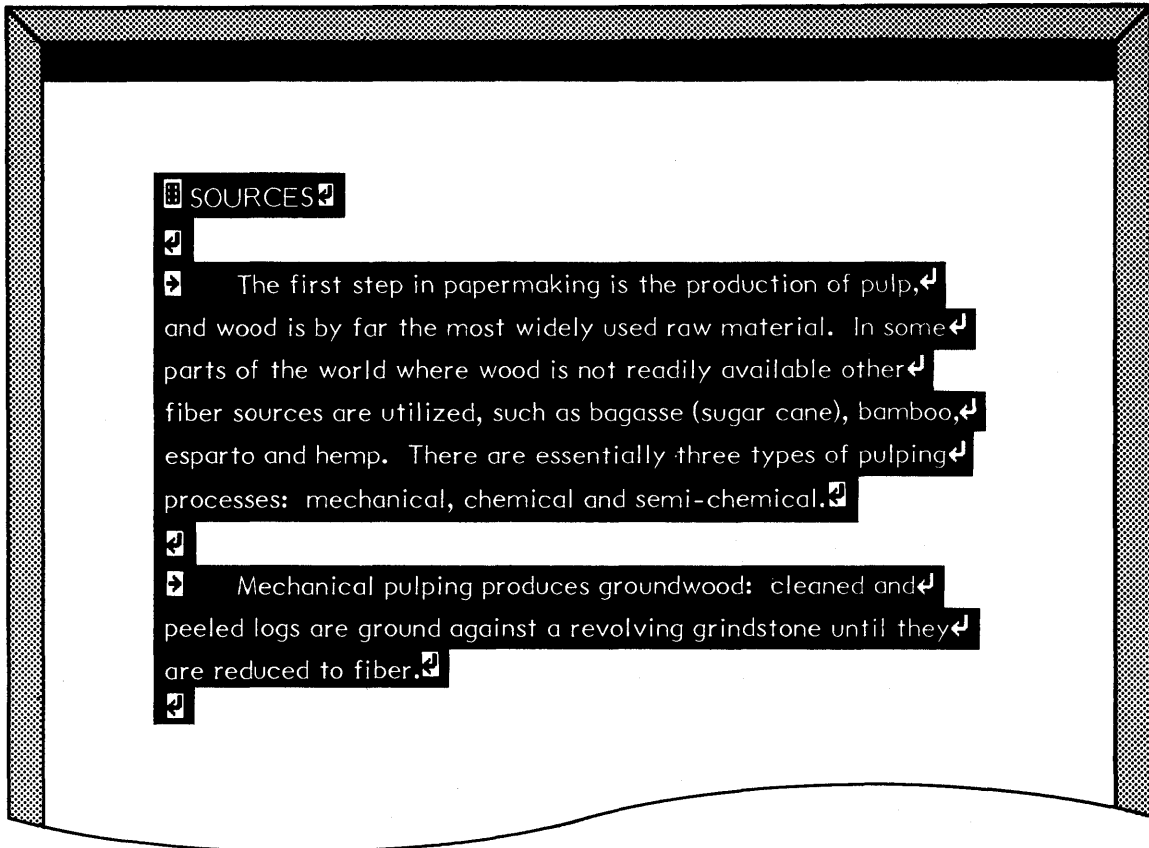

*Highlighted Text
Illustration VI-3*

LOOK at the document on your screen and compare the return symbol after the word **SOURCES** with the return symbols at the end of the other lines.

The symbol after **SOURCES** () is a required return. This symbol appears when you touch the return key. The symbols at the ends of the lines in the paragraph () are regular returns. When the system returns the carrier for you, this symbol appears.

Whenever you want to know how a document was typed, you can highlight it and look at the code symbols. Your Reference Manual has a complete listing of all the symbols.

Removing the Highlighting

Step 3 TOUCH the STOP key once to remove the highlighting.

Result The highlighting is gone.

Highlighting with the Text Keys

You can also highlight parts of the document by using the text keys (PARA, LINE, WORD, and CHAR), located to the right of the keyboard (see Illustration VI-4 below).

The PARAGraph key will highlight one **paragraph** and the carrier returns that follow it.

The LINE key will highlight one **line**.

The WORD key will highlight one **word**.

The CHARacter key will highlight one **character**.

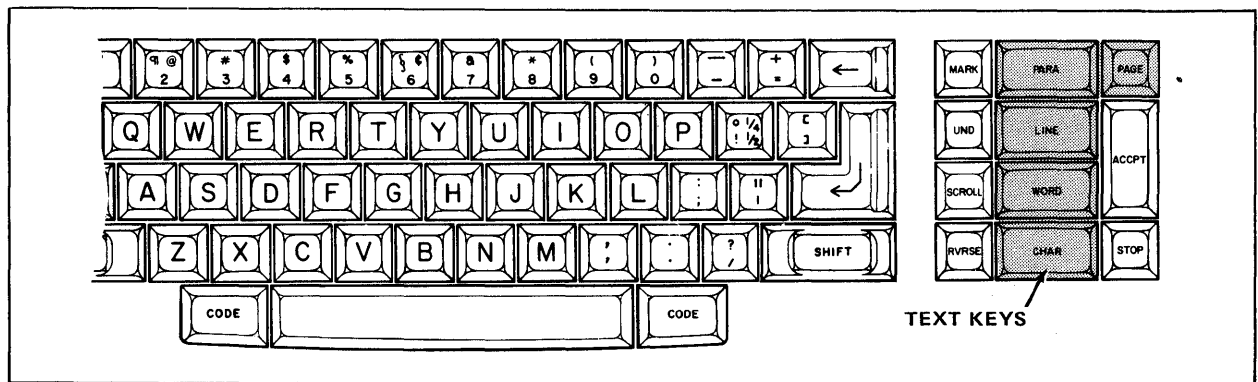

The TEXT Keys
Illustration VI-4

Step 4 TOUCH the PARA (paragraph) key.

Result The first paragraph (the title) is highlighted.

TOUCH PARA two more times to move the highlighting down the screen.

- Step 5** **TOUCH** the LINE key.
- MOVE** the highlighting down the screen by touching the LINE key several times.
- Step 6** **TOUCH** the WORD key.
- MOVE** the highlighting through the words of the text by touching the WORD key several times.
- Step 7** **TOUCH** the CHAR (character) key.
- MOVE** the highlighting over several characters by holding down the CHAR key.
- NOTICE** that the line and character counters in the Command Line are activated when you touch the CHAR key. Anytime you want to know the printing position of a character, you can highlight it with the CHAR key and look at the Command Line.

Moving the Highlighting up the Screen

The text keys move the highlighting down the screen. To reverse and move the highlighting up the screen, hold down the RVRSE key and touch one of the text keys.

- Step 8** **HOLD** down the RVRSE key and touch the PARA key twice to move highlighting back up the screen.
- HOLD** down the RVRSE key and touch the LINE key several times.

- Step 9** **HOLD** down the RVRSE key and touch the WORD key.
- Result The highlighting moves to the carrier return at the end of the highlighted line.
- HOLD** down the RVRSE key and touch WORD several times.
- HOLD** down the RVRSE key and touch the CHAR key.
- Result The highlighting moves to the space at the end of the word.
- HOLD** down the RVRSE key and touch CHAR several times.
- Step 10** **TOUCH** the STOP key to remove the highlighting from the document.

Using the CAT to Highlight Text

Some keyboards have a CAT (see Illustration below). If your keyboard has a CAT, continue with this exercise. If your keyboard does not have a CAT, go to page 10 and continue with the steps there.

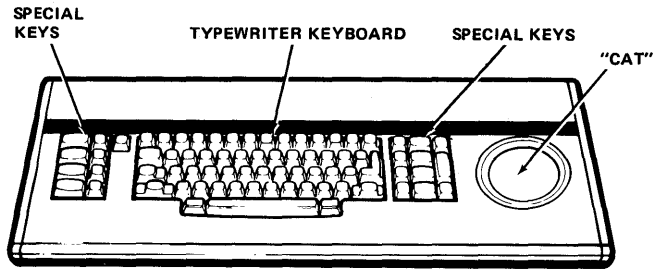

KEYBOARD (WITH CAT)

The **cursor** is a "pointer" you can use to select text (see Illustration VI-5 below).

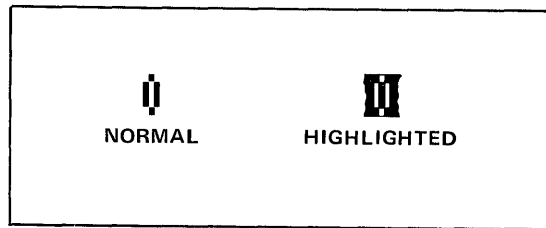

The Cursor
Illustration VI-5

To move the cursor around on the screen, you place your fingers on the outer edge of the CAT. There's no need to push hard. The speed of the cursor is controlled by the number of fingers you place on the pad.

Right now, the cursor should be in the top left corner of your screen (touching the bottom edge of the Command Line) as shown in Illustration VI-6 below. This is the "home" position for the cursor.



Home Position for the Cursor on the Display Screen
Illustration VI-6

- Step 1 TOUCH** the CAT and move the cursor around by placing your fingers (or thumb) along the edge of the pad. Watch the screen to see how the cursor moves as you move your fingers on the CAT (see Illustration VI-7 below).

*Fingers on the CAT
Illustration VI-7*

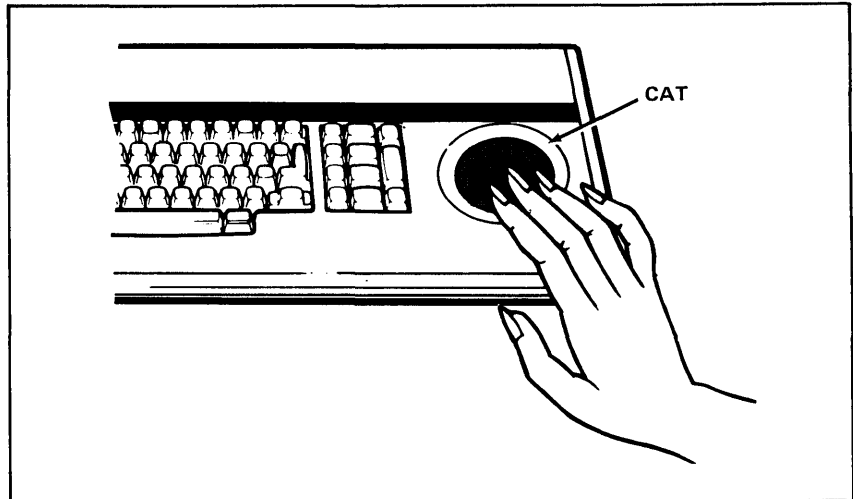

Highlighting Text Near the Cursor

You can highlight the text closest to the cursor by touching one of the text keys.

- Step 2 MOVE** the cursor to any position within the last paragraph of the document.
- TOUCH** the PARA key to highlight the last paragraph.
- TOUCH** the STOP key to remove the highlighting.
- Step 3 MOVE** the cursor to any position within the first paragraph of the document.
- TOUCH** the PARA key to highlight the first paragraph.
- TOUCH** the STOP key to remove the highlighting.
- TOUCH** the STOP key (a second time) to "home" the cursor.
- Result** The cursor returns to its "home" position near the top left corner of the display screen.

ADDING AND DELETING UNDERLINING AND BOLDING

In an earlier lesson, you learned to underline text and bold text. When you have to revise the underlining or bolding, you'll find it easy.

In the example in Illustration VI-8 on the opposite page, the author wants to add and delete underlining and bolding. The steps below and on the following pages will tell you exactly how to make each revision.

Adding Underlining

The first change is to underline the first paragraph. To add underlining, you highlight the text and touch the UND key.

Step 1 **TOUCH** the PARA key until the first paragraph is highlighted.

TOUCH the UND key.

Result The entire first paragraph is underlined.

Adding Bolding

The next change is to bold the word **Mechanical**. To add bolding, you highlight the text and use CODE + 9.

Step 2 **TOUCH** the WORD key until **Mechanical** is highlighted.

HOLD down CODE and touch the 9 key.

Result The highlighted word is bolded. Note that bolding is indicated on the screen with an underline.

Removing Underlining

The next change is to remove the underlining from the third paragraph. To remove underlining, you highlight the text and use the RVRSE key with the UND key.

Step 3 **HIGHLIGHT** the paragraph that is to have the underlines removed (use the PARA key).

HOLD down the RVRSE key and touch UND.

Result The underlines are removed.

SOURCES

underline this paragraph { The first step in papermaking is the production of pulp, and wood is by far the most widely used raw material. In some parts of the world where wood is not readily available other fiber sources are utilized, such as bagasse (sugar cane), bamboo, esparto and hemp. There are essentially three types of pulping processes: mechanical, chemical and semi-chemical.

bold this word Mechanical pulping produces groundwood: cleaned and peeled logs are ground against a revolving grindstone until they are reduced to fiber.

remove underline { Groundwood pulp is very economical since all the wood is used. It does, however, contain impurities which can cause discoloration and weakening of the paper. Its main use is for newsprint. It is also used as a part of the pulp in magazine papers where it contributes bulk, opacity and compressibility.

underline this sentence {Chemical pulping removes most of the lignin, resins, gums and other components of the wood so that the pulp is mainly cellulose fiber.} Papers made from this pulp are much more permanent than groundwood paper. Chemical pulping is done by cooking the wood pulp with chemicals in batch or continuous digesters. There are two main types of chemical wood pulp: sulfite and sulfate. Sulfite pulp is made by cooking chips of coniferous woods like spruce, pine, and hemlock in a liquor made from lime and sulfurous acid. Sulfate pulp, also known as kraft, is produced by cooking broadleaf or coniferous woods with caustic soda and sodium sulfide.

bold these words

remove bolding

Semi-chemical pulping combines chemical with mechanical pulping to produce a pulp with higher yield yet somewhat similar properties to chemical pulp. It is a treatment for hardwoods and is usually used as a blend with chemical pulp imparting stiffness and good foundation.

You may have thought you'd use the delete key to get rid of the underlines, but delete removes everything that is highlighted. In order to remove only the underlines, you tell the system to "reverse" the underlining and remove the underlines without deleting the words.

Removing Bolding

The next change is to delete the bolding from the word **lime**. To delete bolding, you use RVRSE + CODE + 9.

- Step 4** **TOUCH** LINE and WORD until the word **lime** is highlighted. (The word is near the end of the fourth paragraph.)
- HOLD** down the RVRSE and CODE keys and touch 9.
- Result** The bolding has been removed (the underlining disappears).

Marking Words

The next revision is to bold a group of words. You can use the MARK key to tell the 860 to "hold" the highlighting as you continue to touch the text keys.

- Step 5** **HOLD** down RVRSE and touch LINE four times to move the highlighting up the page.
- TOUCH** the WORD key until the word **two** is highlighted.
- TOUCH** the MARK key.
- Result** The first character of the word **two** is highlighted and marked.
- TOUCH** the WORD key three times to highlight three words.
- LOOK** at the screen to verify that three words are now highlighted.
- HOLD** down CODE and touch the 9 key.
- Result** Bolding is added to the three words.

SOURCES

underline this paragraph { The first step in papermaking is the production of pulp, and wood is by far the most widely used raw material. In some parts of the world where wood is not readily available other fiber sources are utilized, such as bagasse (sugar cane), bamboo, esparto and hemp. There are essentially three types of pulping processes: mechanical, chemical and semi-chemical.

bold this word Mechanical pulping produces groundwood: cleaned and peeled logs are ground against a revolving grindstone until they are reduced to fiber.

remove underline { Groundwood pulp is very economical since all the wood is used. It does, however, contain impurities which can cause discoloration and weakening of the paper. Its main use is for newsprint. It is also used as a part of the pulp in magazine papers where it contributes bulk, opacity and compressibility.

underline this sentence {Chemical pulping removes most of the lignin, resins, gums and other components of the wood so that the pulp is mainly cellulose fiber.} Papers made from this pulp are much more permanent than groundwood paper. Chemical pulping is done by cooking the wood pulp with chemicals in batch or continuous digesters. There are two main types of chemical wood pulp: sulfite and sulfate. Sulfite pulp is made by cooking chips of coniferous woods like spruce, pine, and hemlock in a liquor made from lime and sulfurous acid. Sulfate pulp, also known as kraft, is produced by cooking broadleaf or coniferous woods with caustic soda and sodium sulfide.

remove holding { Semi-chemical pulping combines chemical with mechanical pulping to produce a pulp with higher yield yet somewhat similar properties to chemical pulp. It is a treatment for hardwoods and is usually used as a blend with chemical pulp imparting stiffness and good foundation.

The last revision is to underline the first sentence in the paragraph. You'll use MARK to highlight all the words before you underline them.

- Step 6**
- HOLD** down RVRSE and touch LINE until the first line of the paragraph is highlighted.
 - TOUCH** WORD twice to highlight the first word in the paragraph.
 - TOUCH** the MARK key to tell the system you want to highlight several words in a row.
 - CONTINUE** touching the WORD key until the word **fiber** is highlighted.
 - TOUCH** the CHAR key to highlight each letter of the word **fiber**, but don't highlight the period. (If you had used the WORD key, the period would have been highlighted.)
 - TOUCH** the UND key.
 - Result** The sentence is underlined.

Storing the Revised Document Over the Original

- Step 7**
- TOUCH** the STORE key.
 - Result** The Command Line displays STORE DOCUMENT?
 - TOUCH** the ACCPT key to answer "yes".
 - Result** The Command Line displays STORE OVER ORIGINAL?

Since you do want to store the revised version over (in place of) the original, you'll answer "yes" to this message.

- TOUCH** the ACCPT key.
- Result** The revised version is stored on the disc with the same title as the original, but with the next highest entry number. The original document and entry number are removed from the INDEX and placed in the Backup Index.

SOURCES

*underline
this paragraph*

The first step in papermaking is the production of pulp, and wood is by far the most widely used raw material. In some parts of the world where wood is not readily available other fiber sources are utilized, such as bagasse (sugar cane), bamboo, esparto and hemp. There are essentially three types of pulping processes: mechanical, chemical and semi-chemical.

*bold this
word*

Mechanical pulping produces groundwood: cleaned and peeled logs are ground against a revolving grindstone until they are reduced to fiber.

*remove
underline*

Groundwood pulp is very economical since all the wood is used. It does, however, contain impurities which can cause discoloration and weakening of the paper. Its main use is for newsprint. It is also used as a part of the pulp in magazine papers where it contributes bulk, opacity and compressibility.

*underline
this sentence*

{Chemical pulping removes most of the lignin, resins, gums and other components of the wood so that the pulp is mainly cellulose fiber.} Papers made from this pulp are much more permanent than groundwood paper. Chemical pulping is done by cooking the wood pulp with chemicals in batch or continuous digesters. There are two main types of chemical wood pulp: sulfite and sulfate. Sulfite pulp is made by cooking chips of coniferous woods like spruce, pine, and hemlock in a liquor made from lime and sulfurous acid. Sulfate pulp, also known as kraft, is produced by cooking broadleaf or coniferous woods with caustic soda and sodium sulfide.

*bold these
words*

*remove
bolding*

Semi-chemical pulping combines chemical with mechanical pulping to produce a pulp with higher yield yet somewhat similar properties to chemical pulp. It is a treatment for hardwoods and is usually used as a blend with chemical pulp imparting stiffness and good foundation.

Lesson Six--EDIT I

Step 8 **PRINT** the document.

Step 9 **COMPARE** your printed copy with the one shown in Illustration VI-9 on the opposite page. If you forgot to make some of the corrections or are not satisfied with your results, recall the document and make any necessary changes. Then check again.

NOTE When you want to remove both the underlining and bolding from a word, you can do so by touching RVRSE + UND.

SOURCES

The first step in papermaking is the production of pulp, and wood is by far the most widely used raw material. In some parts of the world where wood is not readily available other fiber sources are utilized, such as bagasse (sugar cane), bamboo, esparto and hemp. There are essentially three types of pulping processes: mechanical, chemical and semi-chemical.

Mechanical pulping produces groundwood: cleaned and peeled logs are ground against a revolving grindstone until they are reduced to fiber.

Groundwood pulp is very economical since all the wood is used. It does, however, contain impurities which can cause discoloration and weakening of the paper. Its main use is for newsprint. It is also used as a part of the pulp in magazine papers where it contributes bulk, opacity and compressibility.

Chemical pulping removes most of the lignin, resins, gums and other components of the wood so that the pulp is mainly cellulose fiber. Papers made from this pulp are much more permanent than groundwood paper. Chemical pulping is done by cooking the wood pulp with chemicals in batch or continuous digesters. There are **two main types** of chemical wood pulp: sulfite and sulfate. Sulfite pulp is made by cooking chips of coniferous woods like spruce, pine, and hemlock in a liquor made from lime and sulfurous acid. Sulfate pulp, also known as kraft, is produced by cooking broadleaf or coniferous woods with caustic soda and sodium sulfide.

Semi-chemical pulping combines chemical with mechanical pulping to produce a pulp with higher yield yet somewhat similar properties to chemical pulp. It is a treatment for hardwoods and is usually used as a blend with chemical pulp imparting stiffness and good foundation.

PRACTICE EXERCISE

In this practice exercise, you'll recall **ALPS**, the document you typed in a previous exercise and make the editing changes shown below.

- Step 1 **RECALL** the document titled **ALPS**.
- Step 2 **BOLD** the heading.
- Step 3 **UNDERLINE** the first sentence (use the MARK and WORD keys).
- Step 4 **DELETE** the underlining under the words **all but impossible**.

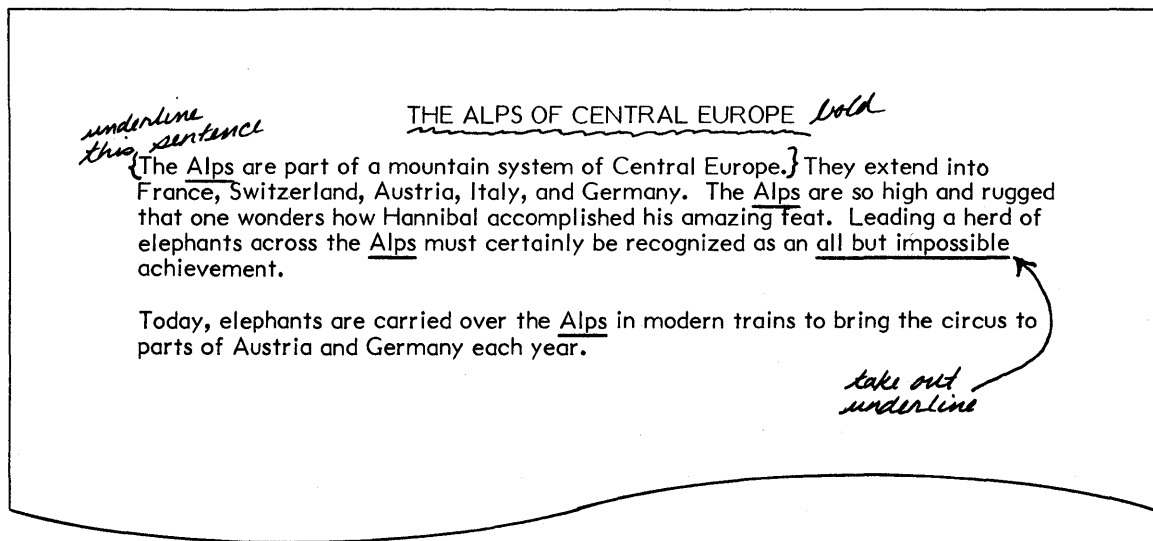

Marked Revisions for the Document **ALPS**
Illustration VI-10

- Step 5 **STORE** the document over the original.
- Step 6 **PRINT** the document.
- Step 7 **COMPARE** the printed document to the one shown in Illustration VI-11 on the next page.

THE ALPS OF CENTRAL EUROPE

The Alps are part of a mountain system of Central Europe. They extend into France, Switzerland, Austria, Italy, and Germany. The Alps are so high and rugged that one wonders how Hannibal accomplished his amazing feat. Leading a herd of elephants across the Alps must certainly be recognized as an all but impossible achievement.

Today, elephants are carried over the Alps in modern trains to bring the circus to parts of Austria and Germany each year.

*Print Version of the Revised Document **ALPS BOLD**
Illustration VI-11*

.....

REVIEW OF

HIGHLIGHTING, ADDING AND DELETING UNDERLINING AND BOLDING

To highlight text using the text keys:

- TOUCH** **CODE + PAGE** to highlight the entire page.
- TOUCH** the **PARA** key to highlight a paragraph.
- TOUCH** the **LINE** key to highlight one line.
- TOUCH** the **WORD** key to highlight one word.
- TOUCH** the **CHAR** key to highlight one character.

To add underlining to an existing document:

- HIGHLIGHT** the text to be underlined.
- TOUCH** the **UND** key.

To delete underlining in an existing document:

- HIGHLIGHT** the text that is underlined.
- HOLD** down the **RVRSE** key and touch the **UND** key.

To add bolding to an existing document:

- HIGHLIGHT** the text to be bolded.
- HOLD** down the **CODE** key and touch **9**.

To delete bolding in an existing document:

- HIGHLIGHT** the text that is bolded.
- HOLD** down the **RVRSE** and **CODE** keys and touch the **9** key.

To **MARK** text for revisions:

- HIGHLIGHT** the first character, word, line or paragraph.
- TOUCH** the **MARK** key.
- TOUCH** the **CHAR**, **WORD**, **LINE**, **PARA**, and/or **PAGE** keys until all the text that is to be revised is highlighted.

MAKING REVISIONS TO TEXT

Almost everything that's typed is also revised. You're probably used to having "first drafts," "second drafts," and at last a "final." On some typewriters, revisions can be a lot of work. The simplicity and ease of making revisions on the 860 system will give you a new viewpoint when work comes back for changes.

Step 1 **RECALL** the document titled **PRINT SECOND**.

As shown in Illustration VI-12 below, you'll be deleting the words **some** and **most of**, and adding a sentence at the end of a paragraph. Then the word **produce** will be changed to **create**. Before you can delete the first word, you have to highlight it. Follow the instructions on the next page to do this.

PULPING

The first step in papermaking is the production of pulp, and wood is by far the most widely used raw material. In ~~some~~ parts of the world where wood is not readily available other fiber sources are utilized, such as bagasse (sugar cane), bamboo, esparto and hemp. There are essentially three types of pulping processes: mechanical, chemical, and semi-chemical.

Mechanical Pulping

Mechanical pulping produces groundwood. Cleaned and peeled logs are ground against a revolving grindstone until they are reduced to fiber. Groundwood pulp is very economical since all the wood is used.

Chemical Pulping

This removes ~~most of~~ the lignin, resins, gums and other components of the wood so that the pulp is mainly cellulose fiber. ←

Semi-Chemical Pulping

This combines chemical with mechanical pulping to ~~produce~~^{create} a pulp with higher yield yet somewhat similar properties to chemical pulp.

*Papers made from this pulp are }
much more permanent than }
groundwood paper.*

*Revisions Marked for the Document PRINT SECOND
Illustration VI - 12*

The first revision is to delete the word **some** in the first paragraph.

Step 1 **TOUCH** the PARA key until the first paragraph is highlighted.

TOUCH the LINE key twice.

TOUCH the WORD key until **some** is highlighted.

Deleting Highlighted Text

In an earlier Lesson, you used the DEL (Delete) key to delete documents from the INDEX. (The DEL key is located next to the FORMAT key at the upper left side of the keyboard.) When you touch the DEL key in a document, the 860 will delete the highlighted text.

Note: Notice the position of the cursor on your screen now (see Illustration VI-13 below). If your keyboard has a CAT, you already know something about the cursor. If you don't have a CAT, this is the first time you will see what the cursor does. The cursor is a pointer that helps to locate text when you are editing.



*Home Position for the Cursor on the Display Screen
Illustration VI-13*

The cursor stays in its "home" position (see Illustration VI-13 above), unless you move it by editing or by using the CAT. As soon as you make the editing change in **Step 2** below, the cursor will move from its "home" position to the point of change.

Step 2 **TOUCH** the DEL key.

Result The word and the space are instantly deleted. The cursor appears in front of the word **parts**.

USING THE SEARCH KEY

Using the text keys to locate a revision point is fast if the next revision is close. If the revision is not close, you can tell the system to find the word or words you want to revise by searching. The SEARCH key is right above the STORE key (see Illustration VI-14 below).

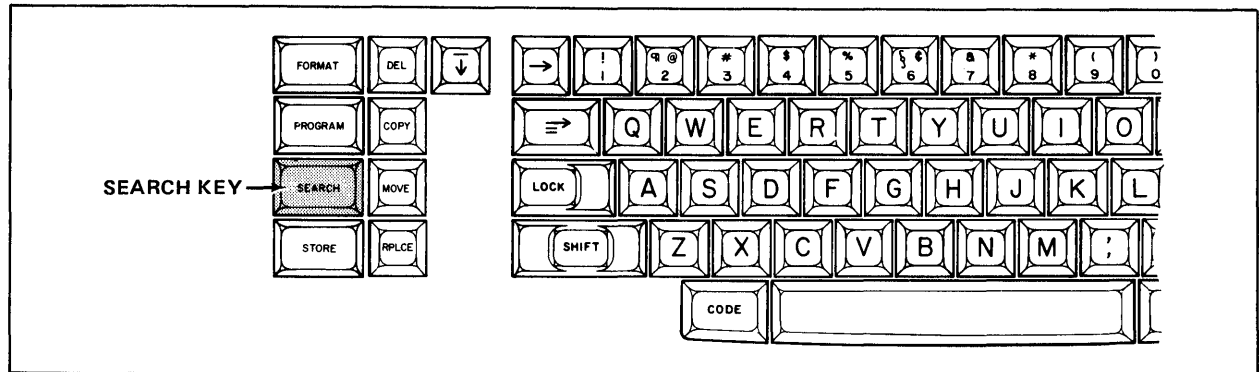

The SEARCH Key
Illustration VI-14

The SEARCH key can be used in three ways: you can search forward, in reverse, or to a specific page in a document. SEARCH works by looking for the exact characters you type into the search instruction. For example, if you misspelled a word, you'd have to tell the system to look for the word exactly as it was misspelled.

Step 1 **TOUCH** the SEARCH key.

Result The Command Line displays:

FORWARD TO: || ||

TOUCH the SEARCH key again.

Result The Command Line now displays:

REVERSE TO: || ||

INSERTING TEXT

To make the next revision (see Illustration VI-15 below), you have to highlight the required carrier return after the word **fiber** in order to insert a new sentence. The quickest way to do this is by using the text keys.

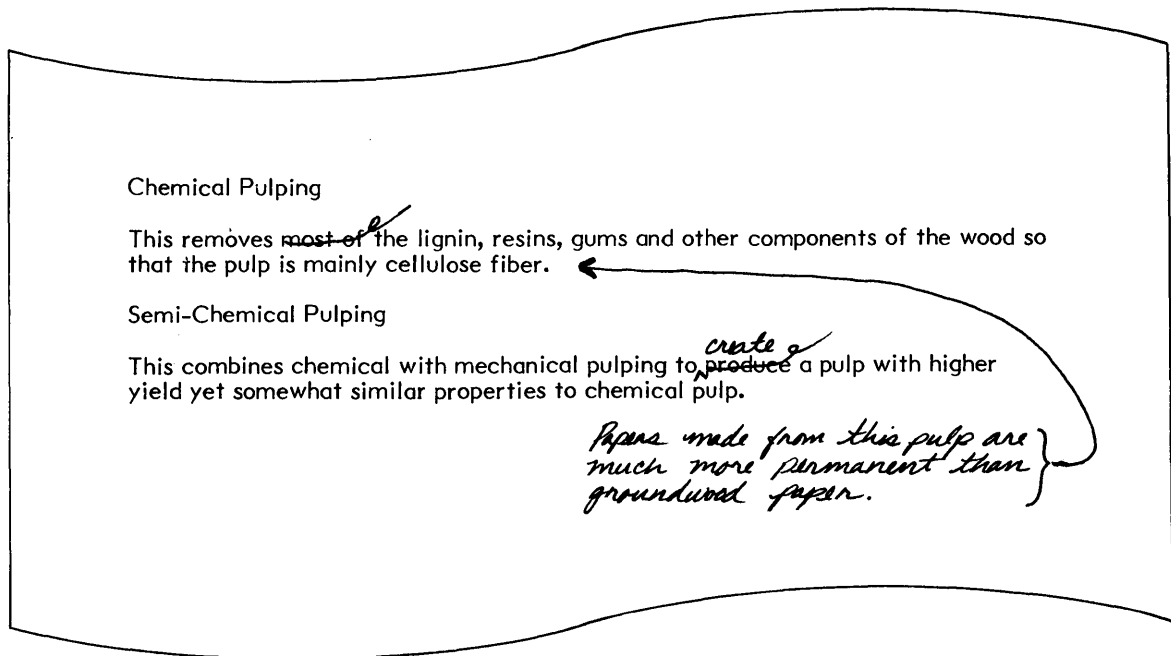

Inserting New Text into the Document PRINT SECOND
Illustration VI-15

Step 5 HIGHLIGHT the second line of this two-line paragraph (use the LINE key).

If you touched CHAR at this point, only the first character of the line would be highlighted. You would then have to hold down CHAR or WORD several times to get to the word "fiber."

However, if you highlight a line and then touch RVRSE and CHAR, the last character of the line will be highlighted.

Lesson Six--EDIT I

- Step 6** **HOLD** down the RVRSE key and touch CHAR.
- Result The required carrier return symbol is highlighted.
- TYPE** two spaces (to end the previous sentence), then type the insertion shown in Illustration VI-16 below. All the new text that you type will go in front of the highlighting.

Note: When you're finished typing the insert, do not add any carrier returns. The returns are already there. The text was inserted in front of them.

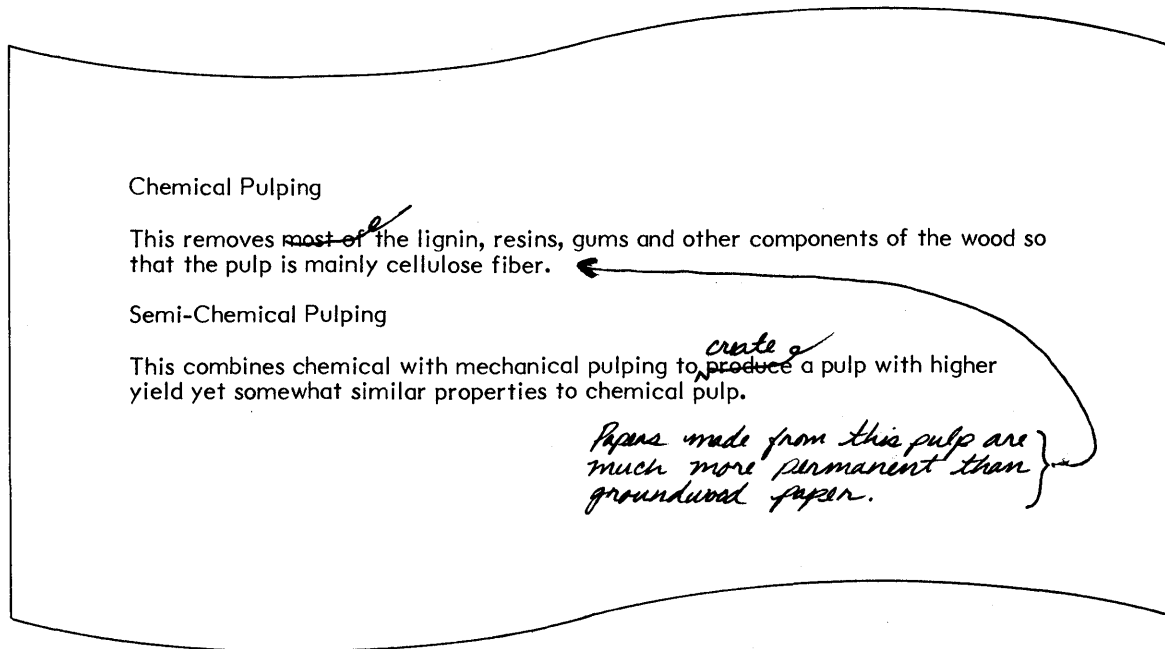

Marked Revisions for the Document **PRINT SECOND**
Illustration VI-16

- Step 7** **TOUCH** the ACCPT key when you've finished typing the insert.
- Result The change has been made and the system is ready for the next revision.

Using the Replace Key

The last change to this document is to replace the word **produce** (in the last paragraph) with the word **create** (see Illustration VI-18 on the next page). This is done using the RPLCE (Replace) key, located next to the STORE key (see Illustration VI-17 below). The RPLCE key will replace highlighted text with other text. This saves time because the old text is automatically deleted as you type the new text.

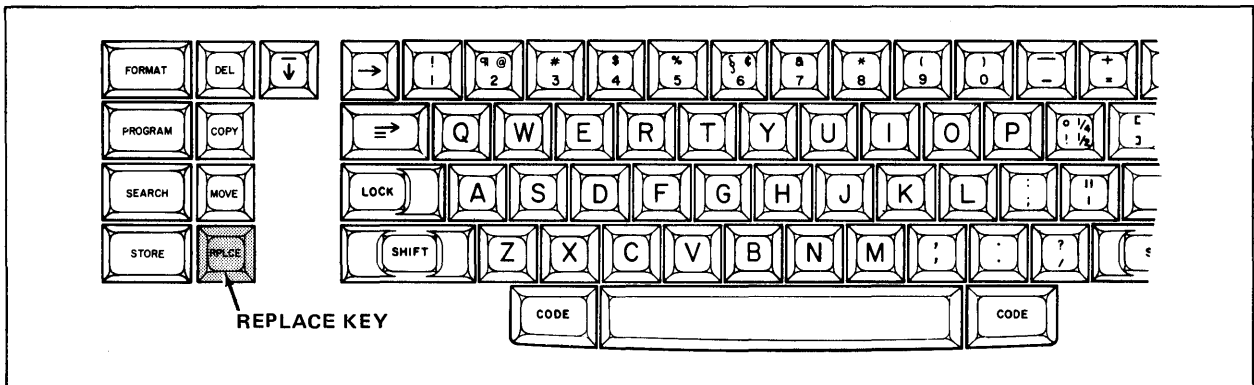

The RPLCE (Replace) Key
Illustration VI-17

Searching and Replacing Text

Step 1 **TOUCH** the SEARCH key.

Result The Command Line displays:

```
FORWARD TO:                    "most of "
```

The system always displays the last search instruction, until you begin typing a new word.

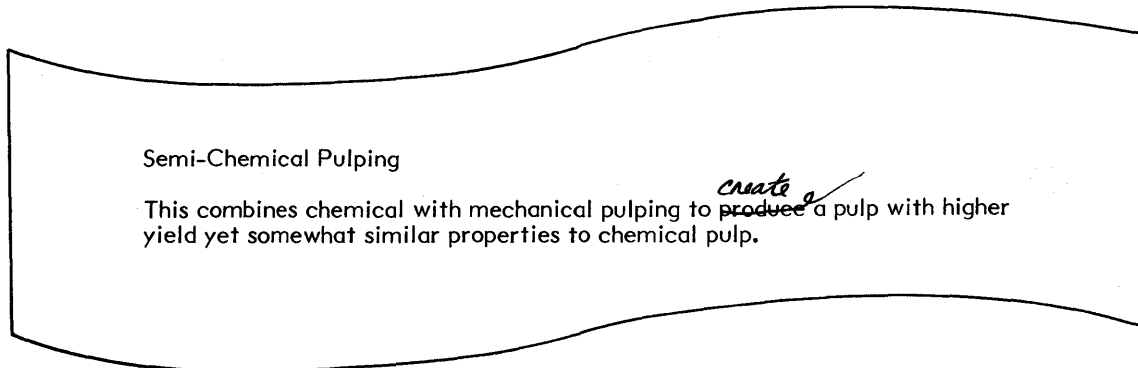

Marked Revisions for the Document **PRINT SECOND**
Illustration VF-18

Step 2 **TYPE** the word **produce** - but don't space after the word since you won't need to replace the space.

Result The Command Line displays:

```
FORWARD TO:                    "produce"
```

TOUCH the ACCPT key.

Result The word **produce** is highlighted.

Step 3 **TOUCH** the RPLCE key.

Result The Command Line displays:

```
REPLACE WITH
```

Step 4 **TYPE** the word **create**. There's no need to space after the word because the space is already there.

Result When you begin typing, the word **produce** is automatically deleted and the word **create** replaces it. (Watch the screen to see how the 860 drops the line down.)

TOUCH the ACCPT key to tell the 860 you've finished the revision.

Step 5 COMPARE your work against the screen version (shown in Illustration VI-19 below).

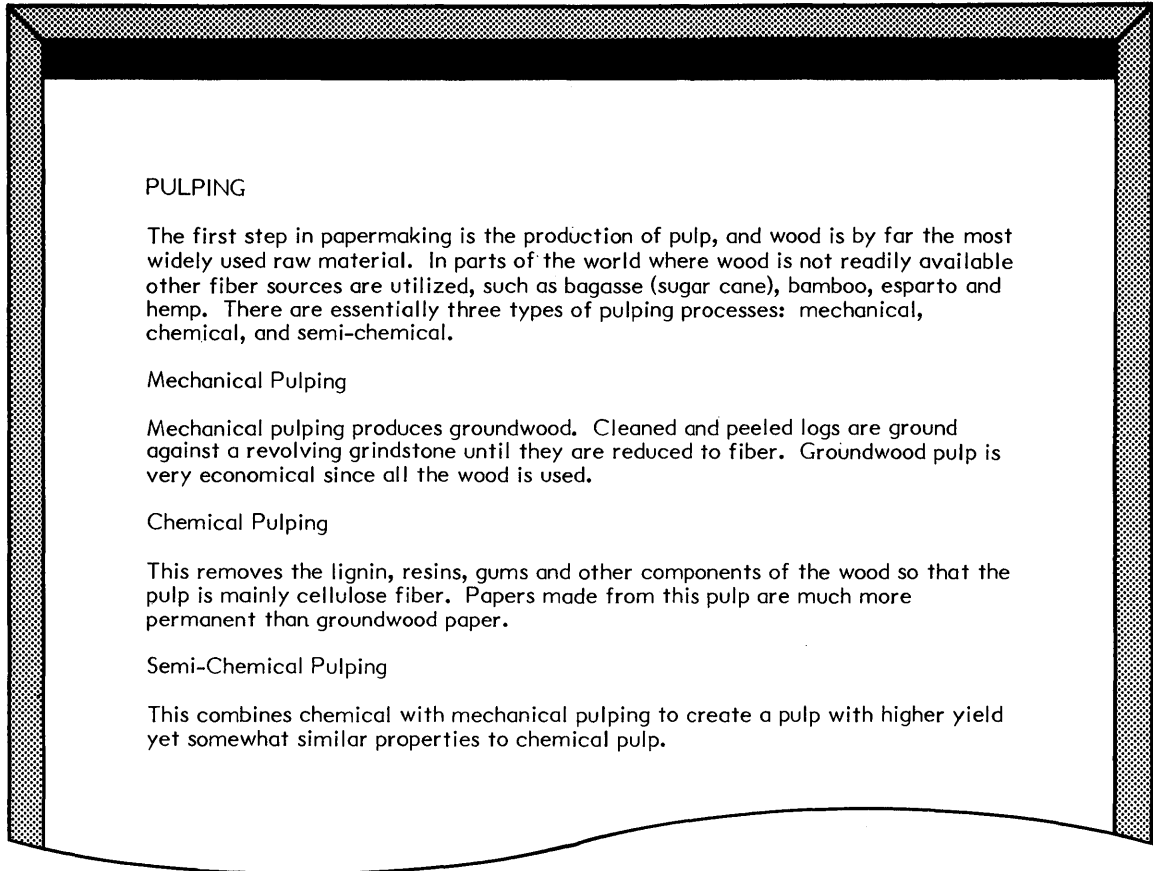

Screen Version of the Document PRINT SECOND
Illustration VI-19

Storing the Revised Document Over the Original

Step 6 **TOUCH** the STORE key.

Result The Command Line displays STORE DOCUMENT?

TOUCH the ACCPT key to answer "yes".

Result The Command Line displays STORE OVER ORIGINAL?

Since you do want to store the revised version over (in place of) the original, you'll answer "yes" to this message.

Step 7 **TOUCH** the ACCPT key.

Result The revised document is stored in the INDEX and the original document is placed in the Backup Index.

.....

REVIEW OF
SEARCHING, DELETING TEXT, REPLACING AND INSERTING TEXT

To have the 860 search forward for a specific word (or words):

- TOUCH** the SEARCH key once.
- TYPE** in the word (or words) to search for.
- TOUCH** the ACCPT key.

To search backwards for a specific word (or words):

- TOUCH** the SEARCH key twice.
- TYPE** in the word (words) to search for.
- TOUCH** the ACCPT key.

To delete text:

- HIGHLIGHT** the text to be deleted.
- TOUCH** the DEL key.

To insert new material into the text:

- HIGHLIGHT** the position for the new text (the text will go in front of the highlighting).
- TYPE** in the new material. (Be sure to add any necessary spaces and carrier returns).
- TOUCH** the ACCPT key.

To replace "old text" with "new text":

- HIGHLIGHT** the word (or words) you want to replace.
- TOUCH** the RPLCE (Replace) key.
- TYPE** the new word (or words).
- TOUCH** the ACCPT key.

MAKING OTHER REVISIONS

In the exercise that follows, you'll be making simple, but larger revisions. Several words and a paragraph are to be deleted and/or replaced. You'll be using the SEARCH key, the TEXT keys, and the CAT to locate the revision points. (If your keyboard does not have a CAT, use the TEXT keys to locate the revisions instead.)

Step 1 **RECALL** the document titled **SLADE GAS** to the screen. This document uses tabs to indent some of the paragraphs. You will learn how to do this in the next lesson.

The changes are shown in Illustration VI-20 below. Follow the instructions below and on the next few pages to make the changes.

all Upper Coal

The **Slade Corporation** has been examining its marketing options in the hope and expectations of developing an intrastate market for natural gas. Three utility companies have expressed an interest.

Midwestern Gas indicated they would be prepared to start taking gas in 1989, ~~at a price~~ subject to negotiation 6 months prior to the first delivery and renegotiation every 3 years thereafter.

~~Western People's Gas has also evidenced an interest in buying the gas directly at a price unspecified, but they require renegotiation on an annual basis.~~

Indiana Gas indicated they would pay 66¢ per *million cubic feet* MCF on an interstate basis of 75¢ per MCF (through their affiliate Western People's Gas). They would not prepay for the gas in an intrastate contract.

Slade Corporation, based on the interest shown by the companies above, may decide to finance the pipeline necessary to create an interstate gas supply throughout the ~~western states.~~ *Western United States and Canada.*

Marked Revisions for the Document **SLADE GAS**
Illustration VI-20

Step 2 **HIGHLIGHT** the third paragraph. (Use the PARA key, or if you have a CAT, move the cursor into or near the paragraph and then touch the PARA key.)

TOUCH the DEL key to delete the paragraph.

Result The paragraph is deleted from the document and the rest of the document moves up the screen.

- Step 3**
- SEARCH** in reverse (touch SEARCH twice).
- TYPE** the words **at a price** and space once.
- TOUCH** the ACCPT key.
- Result** the words **at a price** are highlighted within your document.

Note: If you only typed the word **at** in the search instruction, the system would find these characters in several different words. For example, the words: Corporation, expectatation, intrastate, natatural, and indicatated.

- TOUCH** the DEL key to delete **at a price** and the space.
- Result** The highlighted words are deleted.

Next, you'll change **MCF** to read **million cubic feet** by using the RPLCE key.

- Step 4**
- TOUCH** the SEARCH key and type **MCF** (but no space after it).
- TOUCH** the ACCPT key.
- Result** **MCF** is highlighted.
- TOUCH** the RPLCE key.
- Result** The Command Line displays:
- REPLACE WITH
- TYPE** the words **million cubic feet** (no space is needed after **feet** because a space wasn't included in the SEARCH instruction).
- TOUCH** the ACCPT key.
- Result** The text is automatically rearranged around the revision.

Marking Text for Revisions

The next revision is replacing two words (see Illustration VI-21 below). To do this, you'll use the MARK and WORD keys to highlight both the words.

- Step 5** **TOUCH** the PARA, LINE and WORD keys until the word **western** in the last sentence is highlighted.
- TOUCH** the MARK key once and then touch the WORD key twice.
- Result** The words **western states**. are highlighted. Note that the period is included.
- TOUCH** the RPLCE key.
- TYPE** **Western United States and Canada.**
- TOUCH** the ACCPT key.

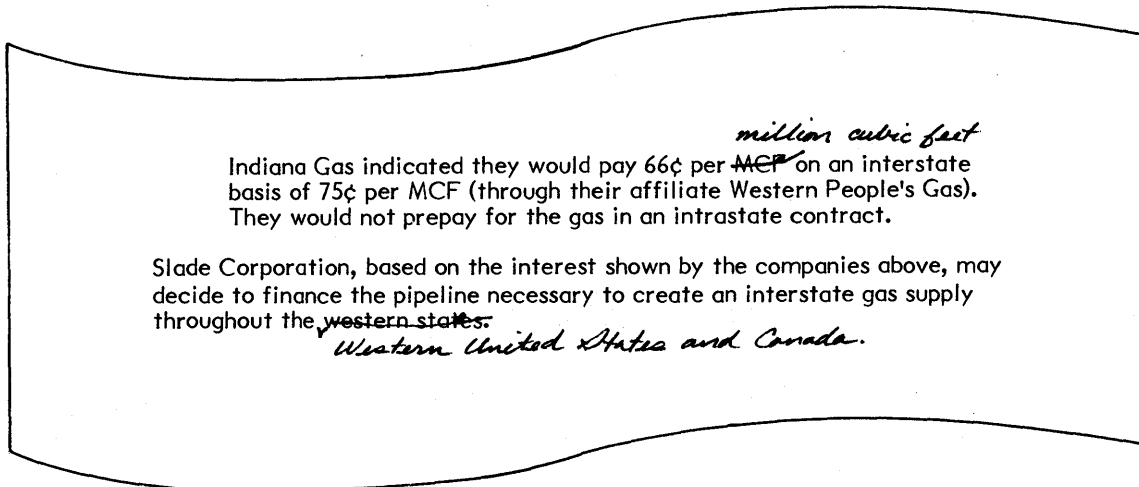

Marked Revisions for the document **SLADE GAS**
Illustration VI-21

Changing Text to All Lower Case or Upper Case

You've just used the RPLCE key to delete unwanted text as you type in new text. There are times, however, when you will want to keep the same text but change to all lower case or upper case characters. The RPLCE key can be used in three different ways. You can replace text with new text, change text to all lower case characters, or to all upper case characters.

Follow the steps below to change the words **Slade Corporation** in the first paragraph to upper case (see Illustration VI-22 below).

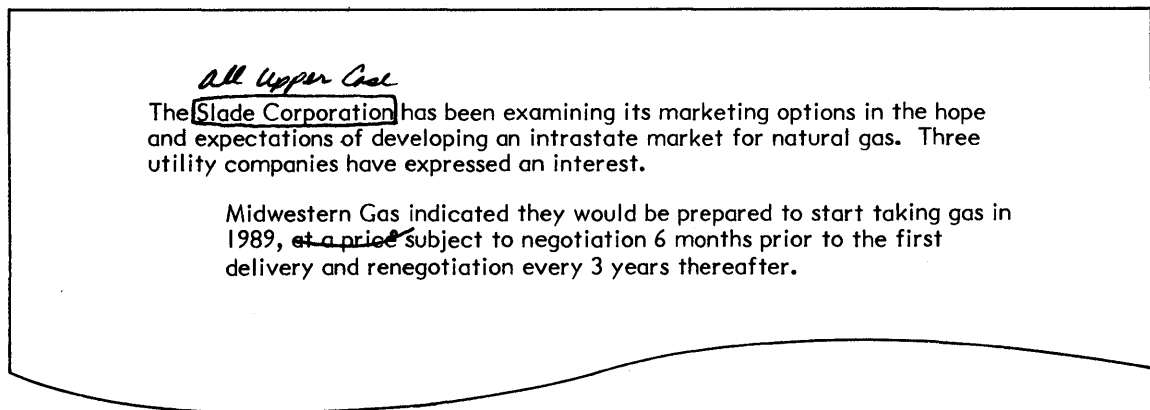

Marked Revisions for the Document **SLADE GAS**
Illustration VI-22

- Step 6** **SEARCH** in reverse (touch SEARCH twice).
- TYPE** the words **Slade Corporation** and space once.
- TOUCH** the ACCPT key.
- Result** The words **Slade Corporation** in the first paragraph are highlighted.
- Note:** If you did not space after typing **Corporation**, the 860 will highlight **Slade Corporation**, in the last paragraph. Touch STOP and try again.

Step 7 TOUCH the RPLCE key twice.

Result The Command Line displays:

REPLACE WITH LOWER CASE

TOUCH the RPLCE key again.

Result The Command Line displays:

REPLACE WITH UPPER CASE

TOUCH the ACCPT key.

Result The highlighted text is automatically changed to all upper case.

Step 8 COMPARE your work against the screen version in Illustration VI-23 below.

If you missed a few of the corrections, go back and try them now. Then compare your work again until you are satisfied with it.

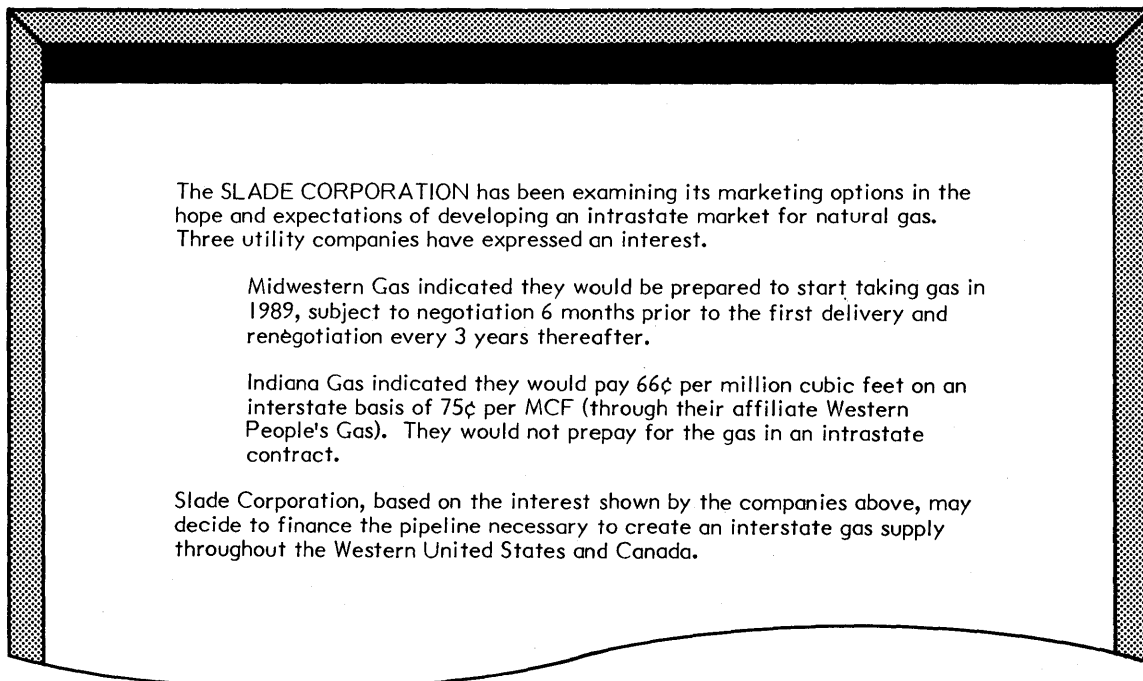

Screen Version of the Document **SLADE GAS**
Illustration VI-23

DOCUMENT STORING DECISIONS

Any time a document is revised, you must decide what to do with the original document and the revision. You have three choices:

1. Save the revised version in place of the original (the usual choice).
2. Save both the revised version and the original.
3. Save only the original.

Saving Both the Revised and Original Documents

You can save both the revision and the original by giving the revision a different title. (If the original document was **MEMO A**, the revision might be titled **MEMO A rev.**) If you choose to do this, you type the new title when the message **STORE OVER ORIGINAL** is displayed.

You just revised the document called **SLADE GAS**. This time you'll keep the revised version and the original version. So you will give **SLADE GAS** a new title.

- | | | |
|---------------|--------------|--|
| Step 1 | TOUCH | the STORE key. |
| | Result | The Activity Page is brought to the screen and the Command Line displays STORE DOCUMENT? |
| | TOUCH | the ACCPT key. |
| | Result | The Command Line displays STORE OVER ORIGINAL? |
| Step 2 | TYPE | the new title for the revision: SLADE REV |
| | TOUCH | the ACCPT key. |
| | Result | The changes you just made to the document are stored under the title SLADE REV . The original document remains on the disc, titled SLADE GAS . |
| | LOOK | at the INDEX. The title SLADE GAS still has its <u>original</u> entry number on the INDEX. The title SLADE REV has been added to the top of the INDEX and given a <u>new</u> entry number. |

Saving the Original But Not the Revised Document

If you don't want to keep a revised document, you can simply delete (erase) the document by touching the STOP key to answer "no" to the Command Line message, STORE DOCUMENT?. Then use the DEL (Delete) key and the ACCPT key to clear the document from the Active List.

.....

REVIEW OF

CHANGING CASE AND STORING DOCUMENTS

This page is a review of the procedures you've learned in this part of the lesson. Read through the procedures to make sure you understand them. Then go on with the lesson.

Changing to Upper or Lower Case

To change text to all upper case:

HIGHLIGHT the text that needs all capital letters.

TOUCH the RPLCE key three times.

TOUCH the ACCPT key.

To change text to all lower case:

HIGHLIGHT the text that needs all lower case.

TOUCH the RPLCE key twice.

TOUCH the ACCPT key.

Storing Revised Documents

To store a revised document over the original:

TOUCH the STORE key.

TOUCH the ACCPT key twice.

To store both a revised document and the original:

TOUCH the STORE key.

TOUCH the ACCPT key once.

TYPE a new title for the revision.

TOUCH the ACCPT key once.

To store only the original (and delete the revised document):

TOUCH the STORE key.

TOUCH the STOP key.

TOUCH the DEL key.

TOUCH The ACCPT key.

.....

PRACTICE EXERCISE

In this practice exercise, you'll recall a document and make the editing changes shown in the illustration below. Then you'll store the revised document under a new title to keep both the revised document and the original in the INDEX.

- Step 1** **RECALL** the document titled **INS. BOOTH**.
- Step 2** **MAKE** the revisions shown in Illustration VI-24 below.

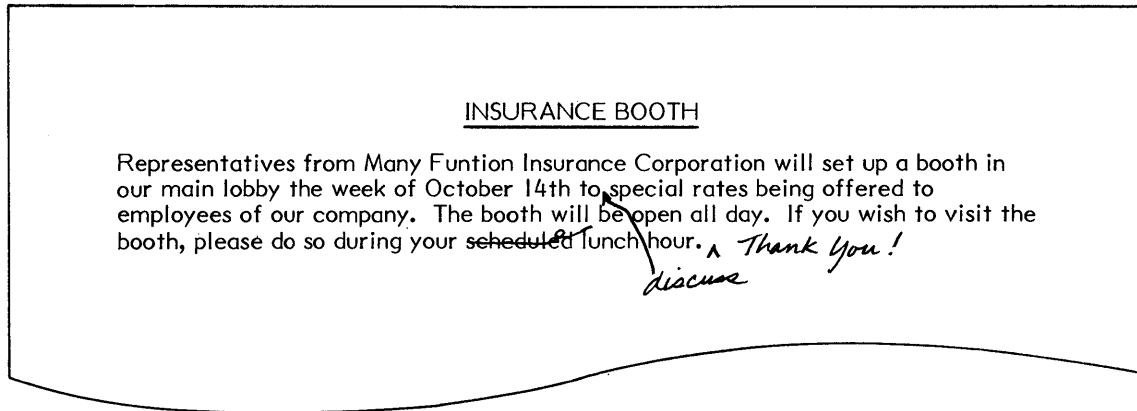

*Marked Revisions for the Document **INS. BOOTH**
Illustration VI-24*

- Step 3** **STORE** the revised document under a new title **INSURANCE BOOTH**
- Step 4** **PRINT** the revised document.
- Step 5** **COMPARE** the printed document to the version shown in Illustration VI-25 on the next page.
- Step 6** **CHECK** that both document titles are listed in the INDEX of your Student Disc: **INS. BOOTH** and **INSURANCE BOOTH**.

INSURANCE BOOTH

Representatives from Many Funtion Insurance Corporation will set up a booth in our main lobby the week of October 14th to discuss special rates being offered to employees of our company. The booth will be open all day. If you wish to visit the booth, please do so during your lunch hour. Thank you!

Print Version of the Document **INSURANCE BOOTH**
Illustration VI-25

Lesson Six--EDIT I

You have now completed Lesson Six. On the next pages there are Points to Remember and an Action Summary for you to review.

There is also a Progress Check for you to complete. If you should answer any of the questions incorrectly, turn to the page indicated in the answer and review the information.

POINTS TO REMEMBER

- In order to delete any information (whether it is a character or an entire paragraph), you highlight the amount of text you want to delete then touch the DEL key. (Page 6-22)
- Using the text keys to locate a revision point is fast if the revision is close to your position on the page. (Page 6-5)
- Instead of using the text keys to locate and highlight text, you can tell the system to find text by using the SEARCH key. (Page 6-23)
- You can search forward, reverse, or to a specific page within a document. (Page 6-23)
- If you have a CAT on your keyboard, you can use it to quickly move the cursor near a revision point and then use the TEXT keys to highlight. (Page 6-8)
- You can insert text anywhere in a document. Inserted text will be entered in front of a highlighted area. (Page 6-26)
- When you make changes to a document and touch the STORE key, the Command Line will display STORE DOCUMENT? Then, when you touch the ACCPT key, you will get the message STORE OVER ORIGINAL? The system is asking you if you want to store the revised document over (in place of) the original. (Page 6-30)
 - If you touch ACCPT again, the revision will be stored over the original.
 - If you type a new title and then touch ACCPT, the revision will be stored under the new title. You will have both the original and the revision in your INDEX.
- The MARK key tells the system to hold the highlighting as you touch the text keys. This way, you can highlight a specific amount of text. (Page 6-34)
- To add underlining or bolding to a document, you highlight the text and touch UND or CODE + 9. To delete underlining from text, you highlight the text and touch RVRSE plus UND. To delete bolding from text, you highlight the text and touch CODE + RVRSE + 9. (Page 6-10)

ACTION SUMMARY

You may want to make a copy of this ACTION SUMMARY and keep it on your desk for quick reference.

Revisions can be made by recalling a document, highlighting the text to be changed and telling the 860 what to do with the text (delete it, replace it, underline it, etc.) When all the changes are made, the document must be stored. You can store the revision over (in place of) the original, or give it a new title to store both the original and the revision.

To revise a document:

- Step 1 RECALL** the document using the following steps:
- Highlight the document title in the INDEX
 - Touch ACCPT twice
- Step 2 MOVE** to the point of revision and highlight the text, using one of the following methods:
- Touch SEARCH, type the text to search for, and touch ACCPT
 - Touch PARA, LINE, WORD, or CHAR to move highlighting down the page
 - Hold down RVRSE and touch the PARA, LINE, WORD, or CHAR to move highlighting up the page
 - Use the CAT to move the cursor near the revision point, then touch PARA, LINE, WORD or CHAR to highlight the text
 - Mark text to be edited by highlighting the first character, touching MARK, and touching PARA, LINE, WORD or CHAR to extend the highlighting
- INSERT** text using the following steps:
- Highlight the position for the new text (the text will go in front of the highlighting)
 - Type the new text
 - Touch ACCPT
- DELETE** text using the following steps:
- Highlight the text to be deleted
 - Touch the DEL key
- REPLACE** text using the following steps:
- Highlight the text to be replaced
 - Touch RPLCE, type the new text, and touch ACCPT
- OR
- Touch RPLCE twice (for lower case) and touch ACCPT
- Touch RPLCE three times (for upper case) and ACCPT

ACTION SUMMARY -- CONTINUED

- Step 3 UNDERLINE** text using the following steps:
- Highlight the text to be deleted
 - Touch the UND key
- REMOVE** underlining using the following steps:
- Highlight the underlined text
 - Hold down RVRSE and touch UND
- Step 4 BOLD** text using the following steps:
- Highlight the text to be bolded
 - Hold down CODE and touch the 9 key
- REMOVE** bolding using the following steps:
- Highlight the bolded text
 - Hold down CODE and RVRSE and touch 9
- Step 5 STORE** the document using one of the following methods:
- To keep both the original and the revision:
 - Touch STORE
 - Touch ACCPT
 - Type a new title for the revision
 - Touch ACCPT
 - To store the revision over the original:
 - Touch STORE
 - Touch ACCPT twice

PROGRESS CHECK

Part I

In this Progress Check exercise, you will edit a document that is now stored on the Student Disc. You will practice using most of the 860 features you learned in this lesson.

When you make the changes, please try to locate the revision points by using as many of the following as possible:

Highlighting with the text keys

The SEARCH key (going forward from the cursor)

The SEARCH key (going backward from the cursor)

The CAT plus the text keys (if you have a CAT)

As you revise the document, check off the highlighting methods you use so you are sure you have practiced as many ways as possible with your keyboard.

1. Recall the document titled **PAPER TIPS**.
2. Make the revisions indicated in Illustration VI-26 on the next page.
3. Store the document under the same title.
4. Print the document.
5. Check your printed copy against the printed version on Page 6 - 48.

lc lc lc lc (Lower Case)
TIPS WHEN ORDERING PAPER

remove underline

Anticipate your needs well in advance. This applies to standard sizes and weights stocked at the mill, as well as special orders in sheets or rolls.

Your merchant represents ^s several paper mills, and cannot be expected to carry the many thousands of stock items. He does carry a ~~number~~ stock of popular items. However, many paper mills can ship overnight to a market many miles distant.

representative

Try to combine items from the same mill to effect a lower price. Special sizes and weights have to be made ~~to~~ order and therefore usually take longer for delivery, depending on mill scheduling.

add underline

and cut

Marked Revisions for the Document **PAPER TIPS**
 Illustration VI-26

Tips When Ordering Paper

Anticipate your needs well in advance. This applies to standard sizes and weights stocked at the mill, as well as special orders in sheets or rolls.

Your merchant represents several paper mills, and cannot be expected to carry the many thousands of stock items. He does carry a representative stock of popular items. However, many paper mills can ship overnight to a market many miles distant.

Try to combine items from the same mill to effect a lower price. Special sizes and weights have to be made and cut to order and therefore usually take longer for delivery, depending on mill scheduling.

*Printed Version of the Revised Document PAPER TIPS
Illustration VI-27*

Part II

Answer each question by filling in the blank with the correct answer, then compare your answers with those on Page 6-51.

1. Touching the SEARCH key once instructs the system to search going forward. How do you tell the system to search for a word in reverse?

2. When you touch the DEL (delete) key, any text that is _____ will be deleted.
3. If you want to highlight several words in a row, you can highlight the first word, then touch the _____ key, and continue touching WORD until all the words are highlighted.
4. In order to search to a word, you touch the SEARCH key, type the exact characters you want to find, then touch _____.
5. To delete the underlining from text without deleting the text, you highlight the text and use the _____ and _____ keys.
6. To remove highlighting, you touch the _____ key once.
7. To change letters to all upper case, you highlight the letters to be changed, touch the _____ key _____ times and touch the _____ key.
8. To put the cursor in the "home" position, you touch the _____ key
_____.

(This page is intentionally left blank.)

ANSWERS TO PROGRESS CHECK -- PART II

If you are uncertain or answered a question incorrectly, refer to the pages listed on this answer form to review the original material. When you feel comfortable with the material, return to this point in the lesson and continue.

1. Touching the SEARCH key once instructs the system to search going forward.
How do you tell the system to search for a word in the reverse? (Page 6-23)
Touch the SEARCH key twice
2. When you touch the DEL (delete) key, any text that is highlighted will be deleted. (Page 6-22)
3. If you want to highlight several words in a row, you can highlight the first word, then touch the MARK key, and continue touching WORD until all the words are highlighted. (Page 6-34)
4. In order to search to a word, you touch the SEARCH key, type the exact characters you want to find, then touch ACPT. (Page 6-23)
5. To delete the underlining from text without deleting the text, you highlight the text and use the RVRSE and UND keys. (Page 6-10)
6. To remove highlighting, you touch the STOP key once. (Page 6-5)
7. To change letters to all upper case, you highlight the letters to be changed, touch the RPLCE key 3 times and touch the ACPT key. (Page 6-35)
8. To put the cursor in the "home" position, you touch the STOP key twice. (Page 6-9)

(This page is intentionally left blank.)

Xerox 860 IPS Operator Manual
Book One: Fundamentals

Lesson Seven – Format I
Changing the Format

LESSON SEVEN

FORMAT I

Changing the Format

OBJECTIVES

After finishing this lesson, you will be able to:

- change margin settings, set tabs, and change the line spacing
 - type text with initial indents and/or block indents
 - change the screen display options
 - print the codes in a document
 - create documents with more than one format block
 - right justify text in a document
 - reformat ragged right or right justified text
 - make hyphenation decisions
 - clear a revised document (storing only the original)
-

Materials Needed

For this lesson you will need:

- Student Disc
- System Disc
- Printer and Paper
- Reference Manual

PRELIMINARY ACTIVITIES

Make sure the 860 System is ready for typing:

- System ON.
- ACTIVITY PAGE displayed.
- Student Disc in left disc station.
- System Disc in right disc station.
- INDEX: Student Disc highlighted.

If your 860 is set up correctly, the screen should look like Illustration VII-1 below.

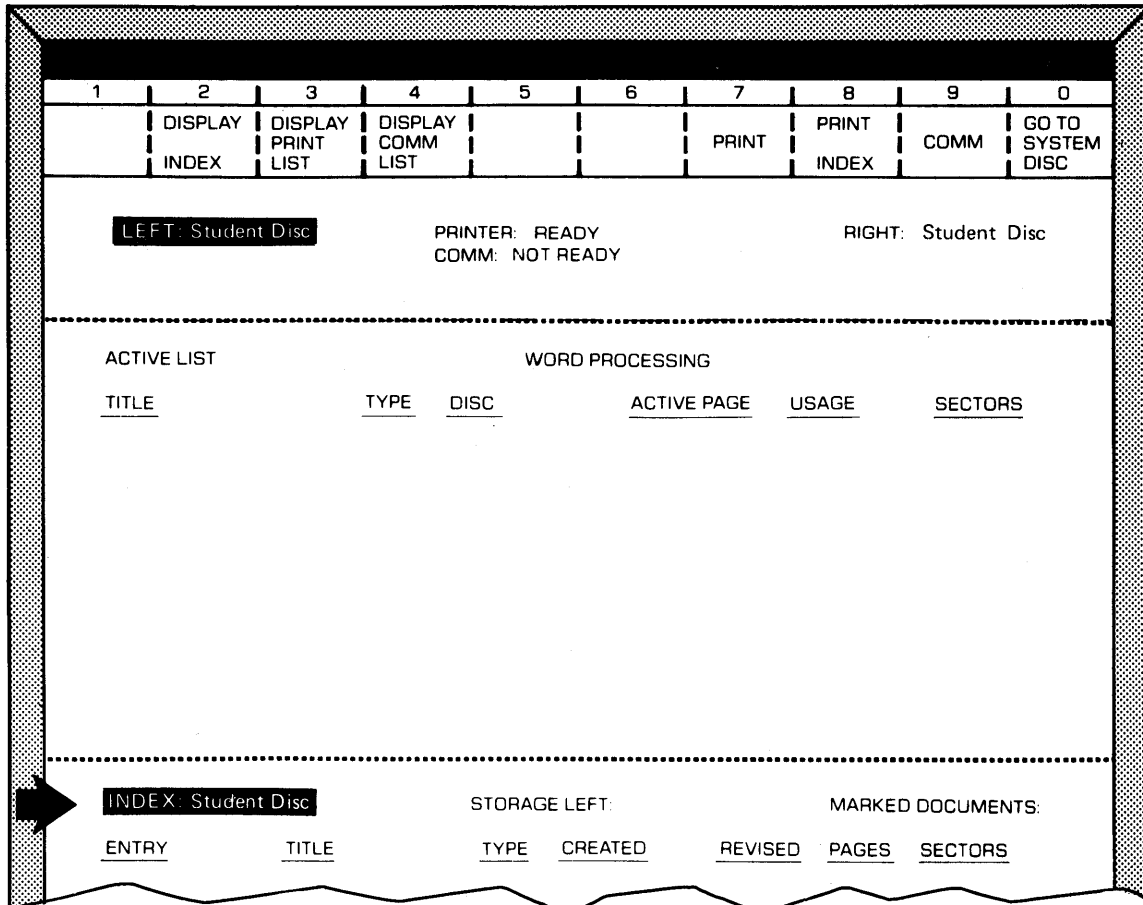

The Activity Page
Illustration VII-1

FORMATTING

A "format" is the way text is laid out on the page. The 860 system has many features that will allow you to format documents quickly and easily.

Each document has its own margins, tabs, and line spacing. Usually, rough drafts are typed in double spacing while the final version is printed in single. Some documents may have only one or two tabs set, while tables and statistical documents have many tabs.

The 860 Information Processing System lets you record the margins, tabs, and line spacing with the document. Each time the document is recalled or printed, the margins, tabs, and line spacing will be exactly what you want.

This information is recorded in the document's **Format Block**, the domino-like block at the beginning of each document (see Illustration VII-2 below).



*The Format Block Symbol
Illustration VII-2*

When you start a new document or recall an old one, you can touch the FORMAT key to check the margin and tab settings in the Format Block. For new documents, the 860 automatically sets margins of 12 and 84, with no tabs and single line spacing.

SETTING A FORMAT

In this exercise, you'll begin a new document and change the margins, tabs, and line spacing in the Format Block. To look at the Format Block information, you'll be using the FORMAT key (see Illustration VII-3 below).

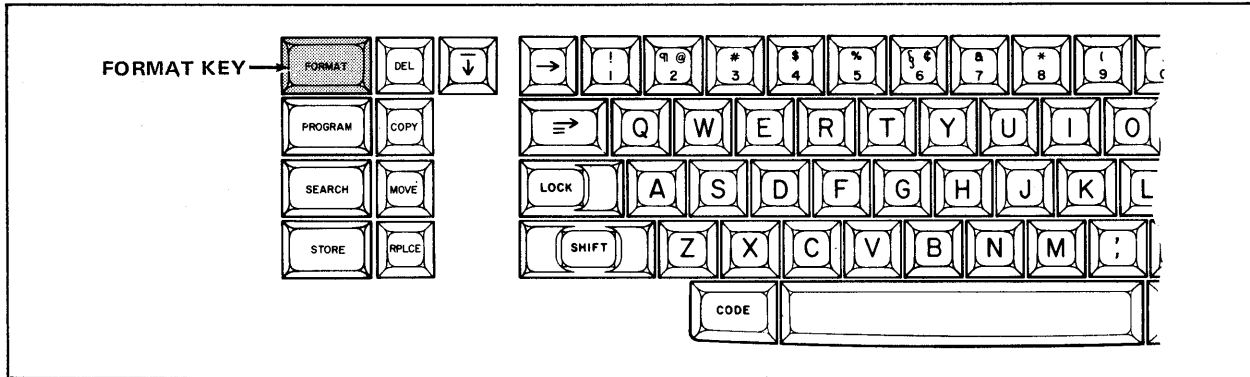

The Format Key
Illustration VII-3

Step 1 HIGHLIGHT the **INDEX: Student Disc.** (You'll record this exercise on your Student Disc.)

Step 2 TYPE **FLEXOGRAPHIC** for the title.

TOUCH the **ACCPT** key three times.

Result A new document titled **FLEXOGRAPHIC** has been started and the first page brought to the screen.

Before you begin typing the text of the new document, you'll tell the system that you want to set new margins, tabs, and line spacing.

Step 3 TOUCH the **FORMAT** key.

Result The Recordable Format Page is brought to the screen.

The Recordable Format Page

The Format Block contains two pages of information. The first one is the Recordable Format Page (see Illustration VII-4 below).

The Recordable Format Page consists of three sections. The first section contains the margins, tabs, line spacing, and keyboard/print wheel information. The second section controls placement of the document on the page. The last section contains the header and trailer options. The text keys, CHAR, LINE, and PARA, are used to highlight and turn on or off the different options on the Format Page.

RECORDABLE FORMAT PAGE

<p>MARGINS</p> <p>TABS / SPEC TABS</p> <p>LINE SPACING</p> <p>JUSTIFY</p> <p>PITCH</p> <p>KB/PW</p> <p>PRINT WHEEL ID</p>	<p>12 84</p> <p>1 1½ 2 3</p> <p>PS 10 12</p> <p>STD LEGAL</p>						
<p>PAGE LAYOUT</p> <table style="width: 100%; border-collapse: collapse;"> <tr> <td style="width: 80%;">TOP MARGIN</td> <td style="text-align: right;">6</td> </tr> <tr> <td>BOTTOM MARGIN</td> <td style="text-align: right;">6</td> </tr> <tr> <td>PAPER SIZE</td> <td style="text-align: right;">66</td> </tr> </table>		TOP MARGIN	6	BOTTOM MARGIN	6	PAPER SIZE	66
TOP MARGIN	6						
BOTTOM MARGIN	6						
PAPER SIZE	66						
<p>PAGE LABELS - SPACES REMAINING 189</p> <table style="width: 100%; border-collapse: collapse;"> <tr> <td style="width: 80%;">PAGE LABEL NUMBER</td> <td style="text-align: right;">1</td> </tr> </table>		PAGE LABEL NUMBER	1				
PAGE LABEL NUMBER	1						
<p>HEADER</p> <p>TRAILER</p> <p>COMMENTS</p>							

*The Recordable Format Page
Illustration VII-4*

Changing the Margins

Look at the Format Page on your screen and notice that the word MARGINS is highlighted. To change the left margin setting, you simply type the new margin.

Step 4 **TYPE** the number **18**
Result The MARGINS line now reads: MARGINS 18 84.

Note: If you get the message UNACCEPTABLE NUMBER -- RE-ENTER displayed on the Command Line, it means that what you typed is not acceptable for a margin. Probably the shift lock is down. If it is, release it, then retype the number.

To change the right margin setting, you touch CHAR to move the highlighting to the right margin setting, then type the new number.

Step 5 **TOUCH** the CHAR key to highlight the right margin setting.

TYPE the new margin: **85**
Result The margins are now set at 18 and 85.

LOOK at the new margin settings on your screen.

The LINE key is used to move the highlighting to the next line on the Format Page. The CHAR key is used to move the highlighting from one choice to another. If you accidentally touch LINE too many times, you can hold down RVRSE and touch the LINE key to move back.

Setting Tabs

To set a tab, you type the position of the tab and touch the LOWER TAB key. The LOWER TAB key has (⇨) on its key cap (see Illustration VII-5 below).

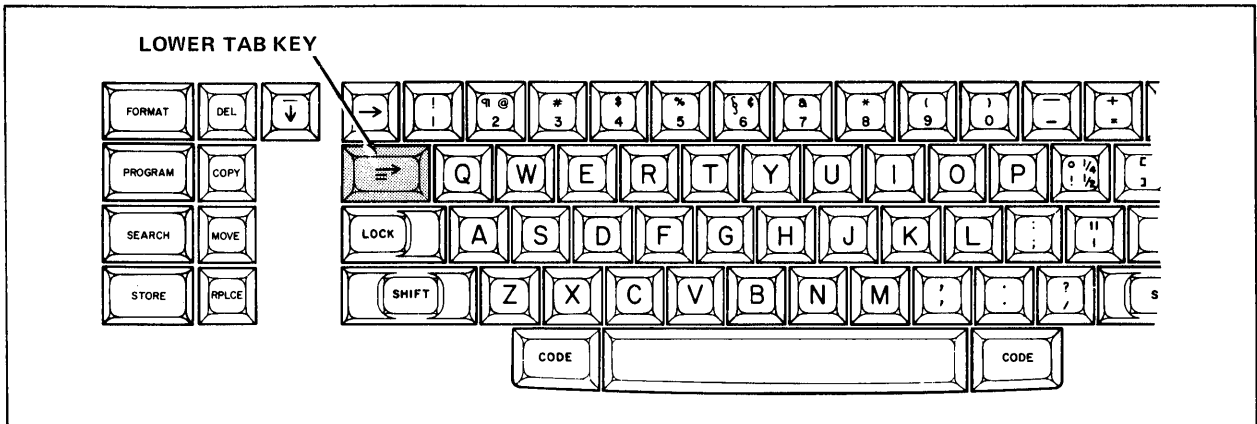

The LOWER TAB Key
Illustration VII-5

- Step 6** **TOUCH** the LINE key to highlight TABS / SPEC TABS
- TYPE** the number **23**.
- Result** The number appears on the TAB line.
- TOUCH** the LOWER TAB key.
- Result** A tab position is set at 23.
- LOOK** at your screen and locate the new tab setting.

In summary, whenever you need to set tabs, highlight TABS / SPEC TABS, type the position where you want the tab, then touch the LOWER TAB key. You can set as many tabs as you want and you don't have to type them in any special order - the system will automatically put them in numerical order.

Changing the Line Spacing

To change the line spacing, you touch the LINE key to highlight LINE SPACING. Then you use the CHAR key to highlight the line spacing you want. You can choose single, one and one-half, double, or triple.

- Step 7** **TOUCH** the LINE key to highlight LINE SPACING.
- TOUCH** the CHAR key.
- Result** The highlighting moves from single space to one-and-a-half.
- TOUCH** the CHAR key again.
- Result** The highlighting is now on double spacing. (If you accidentally went too far, just hold down RVRSE and touch CHAR to move the highlighting backwards.)
- LOOK** at your screen to verify that double spacing (2) is highlighted.

Recording the New Format

Now that you have selected and set the format you want, you need to record it in your document. Touching the ACCPT key removes the Format Page from the screen and records the format with the document.

- Step 8** **TOUCH** the ACCPT key.
- Result** The new margins, tabs, and line spacing are now recorded with the document. Every time you recall this document or print it, it will have the format you just recorded.
- LOOK** at the CHAR counter in the Command Line. It should read 18.
- Step 9** **TYPE** the first paragraph shown in Illustration VII-6 on the next page, then touch the RETURN key twice.

Turn to the next page for instructions on how to type the rest of the document.

Flexographic Presses are web-fed letterpress machines. There are at least two types:

The Stack Type Press has two or three printing units placed vertically in stacks. A press may consist of two or three stacks, with unwind, rewind, sheeter or cutter and creaser.

The Central Impression Cylinder Press is like the common impression system of rotary letterpress and is used extensively for printing flexible films.

Flexography uses rubber plates and water- or solvent-based inks in simple two-roller inking systems. It is an inexpensive and simple printing process used extensively for decorating and packaging printing.

*Text for the Document FLEXOGRAPHIC
Illustration VII-6*

USING THE LOWER TAB KEY

The next three paragraphs of this exercise are indented on every line. On a manual typewriter, you'd have to type, carrier return, and tab or space in for every line in every paragraph.

The 860 has a paragraph indent tab that automatically indents every line after you indent the first one. The LOWER TAB key is the paragraph indent tab.

- Step 1** **TOUCH** the LOWER TAB key.
- TYPE** the second paragraph of the document (shown in Illustration VII-7 on the opposite page). Do not touch the RETURN key until you reach the end of the paragraph.
- Result** As you type, the second and third lines of the paragraph are automatically indented for you.
- TOUCH** the RETURN key twice after typing the paragraph.
- Result** When you type a return from the keyboard, the system understands that the paragraph is finished and returns to the left margin.
- LOOK** at your screen to see the indented paragraph.
- Step 2** **TYPE** the next paragraph using the following steps:
- Touch the LOWER TAB key
 - Type the paragraph, letting the system return the carrier for you until the paragraph is finished
 - End the paragraph with two returns from the keyboard
- Step 3** **TYPE** the last paragraph. (You don't need to use the tab key.)
- END** the document with a carrier return.
- Step 4** **STORE** the document using the following steps:
- Touch STORE
 - Touch ACCPT

Flexographic Presses are web-fed letterpress machines. There are at least two types:

The Stack Type Press has two or three printing units placed vertically in stacks. A press may consist of two or three stacks, with unwind, rewind, sheeter or cutter and creaser.

The Central Impression Cylinder Press is like the common impression system of rotary letterpress and is used extensively for printing flexible films.

Flexography uses rubber plates and water- or solvent-based inks in simple two-roller inking systems. It is an inexpensive and simple printing process used extensively for decorating and packaging printing.

*Text for the Document FLEXOGRAPHIC
Illustration VII-7*

Step 5 **PRINT** the document.

COMPARE your work against the printed copy in Illustration VII-8 below.

Flexographic Presses are web-fed letterpress machines. There are at least two types:

The Stack Type Press has two or three printing units placed vertically in stacks. A press may consist of two or three stacks, with unwind, rewind, sheeter or cutter and creaser.

The Central Impression Cylinder Press is like the common impression system of rotary letterpress and is used extensively for printing flexible films.

Flexography uses rubber plates and water- or solvent-based inks in simple two-roller inking systems. It is an inexpensive and simple printing process used extensively for decorating and packaging printing.

*Printed Version of the Document FLEXOGRAPHIC
Illustration VII-8*

You've learned how to use the LOWER TAB key to set tabs on the Format Page and to automatically indent every line of a paragraph. In this next exercise, you'll learn how to indent only the first line of a paragraph.

Step 1 **CREATE** a new document, titled **BEGINNINGS** (Type **BEGINNINGS**, then touch the ACCPT key three times.)

Each time you start a new document, it will have the standard settings in the format block. For this exercise, you'll need to change the margins, tabs, and line spacing.

Step 2 **TOUCH** the **FORMAT** key and change the margins using the following steps:

- Type **15**
- Touch **CHAR** and type **75**

Result The margins now read **15** and **75**.

Step 3 **SET** a tab at **20** using the following steps:

- Touch **LINE** to highlight **TABS / SPEC TABS**
- Type **20**
- Touch the **LOWER TAB** key

Result A tab is set at **20** and displays on the **TABS / SPEC TABS** line.

Step 4 **TOUCH** **LINE** to highlight **LINE SPACING**.

TOUCH the **CHAR** key to highlight **1½**.

Step 5 **TOUCH** the **ACCPT** key to record the new format settings.

Result The Format Page is removed and the first page of the new document returns to the screen.

LOOK at the **CHAR** counter in the Command Line. It should read **15**.

Lesson Seven—FORMAT I

The document for this exercise is shown in Illustration VII-10 on the next page. Use the instructions below to center the heading and learn how to indent only the first line of each paragraph.

Step 6 **CENTER** and **bold** the heading and touch the RETURN key twice (see Illustration VII-10 on the opposite page).

USING THE UPPER TAB KEY

To indent only the first line of a paragraph, touch the UPPER TAB key (→) at the beginning of the paragraph (see Illustration VII-9 below). The system will indent the first line and automatically return to the left margin on the next line.

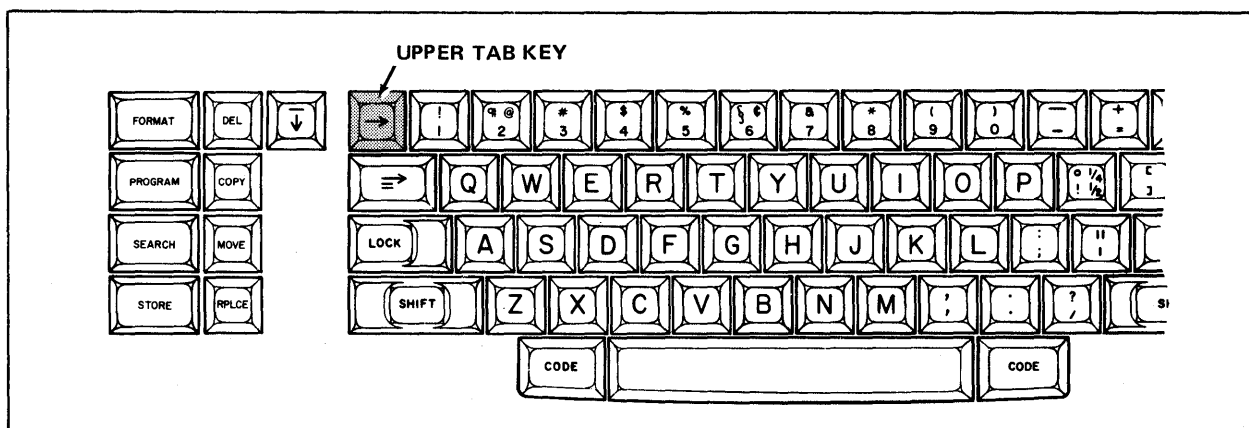

The UPPER TAB Key
Illustration VII-9

Step 7 **TOUCH** the UPPER TAB key once and type the first paragraph. (Remember to let the 860 return the carrier within the paragraph.)

END the paragraph with two returns.

Result Only the first line of the paragraph is indented.

- Step 8** **TYPE** the rest of the document. Remember to use the UPPER TAB key for each paragraph.
- Mistake? If you accidentally touch the LOWER TAB key, backspace it out, then touch the UPPER TAB key and continue typing.
- END** the document with a return.
- Step 9** **STORE** the document when you're finished.
- Step 10** **PRINT** the document.
- Step 11** **COMPARE** your work against the copy in Illustration VII-10 below.

TYPE BEGINNINGS

Our common type faces are either imitations of early handwritten letters or represent a modification of early type faces which, in turn, were modeled after the lettering in manuscript books.

The standard roman lower case letters and capitals assumed their present form about 1470 in a face cut by Nicholas Jenson.

While Jenson, a Frenchman, learned printing in Germany, he did his first printing in Venice, Italy.

*Text for the Document BEGINNINGS
Illustration VII-10*

PRACTICE EXERCISE

- Step 1 CREATE** a new document called **TAB PRACTICE**.
- Step 2 SET** the following format:
- Margins at 18 and 85
 - Tab at 23
 - Double line spacing
- TOUCH** ACCPT.
- Step 3 TYPE** the document shown in Illustration VII-12 on the next page.
- Use the UPPER TAB key to indent the first line of the first and last paragraphs.
 - Use the LOWER TAB key to indent the middle three paragraphs.
- Step 4 STORE** the document.
- Step 5 PRINT** the document.
- Step 6 COMPARE** your document to Illustration VII-12 on the next page.

The Slade Corporation has been examining its marketing options in the hope and expectations of developing an intrastate market for natural gas. Three utility companies have expressed an interest:

Midwestern Gas indicated they would be prepared to start taking gas in 1989, at a price subject to negotiation 6 months prior to the first delivery and renegotiation every 3 years thereafter.

Western People's Gas has also evidenced an interest in buying the gas directly at a price unspecified, but they require renegotiation on an annual basis.

Indiana Gas indicated they would pay 66¢ per MCF on an interstate basis of 75¢ per MCF (through their affiliate Western People's Gas). They would not prepay for the gas in an intrastate contract.

Slade Corporation, based on the interest shown by the companies above, may decide to finance the pipeline necessary to create an interstate gas supply throughout the western states.

*Text for the Document TAB PRACTICE
Illustration VII-12*

.....

REVIEW OF

SETTING A FORMAT AND USING THE UPPER AND LOWER TAB KEYS

The next two pages are a review of the procedures you've learned in this part of the lesson. Read through the procedures to make sure you understand them. Then go on with the lesson.

Setting a Format

To bring Recordable Format Page to the screen:

TOUCH the FORMAT key.

To change the margins:

HIGHLIGHT the MARGINS line (use the LINE key).

TYPE new left margin number.

HIGHLIGHT the right margin setting (use the CHAR key).

TYPE new right margin number.

To set the tabs:

HIGHLIGHT the TABS / SPEC TABS line.

TYPE the first tab number.

TOUCH the LOWER TAB key.

TYPE the next tab number.

TOUCH the LOWER TAB key. Continue until all the tabs have been set.

REVIEW -- CONTINUED

Setting a Format continued

To set the line spacing:

HIGHLIGHT the LINE SPACING line (use the LINE key).

HIGHLIGHT the selected line spacing (use the CHAR key or RVRSE + CHAR keys).

To record the new format:

TOUCH the ACCPT key.

Using the UPPER TAB Key

To indent only the first line of a paragraph:

TOUCH the UPPER TAB key.

TYPE the text to be indented.

Using the LOWER TAB Key

To indent all the lines in a paragraph to a selected tab:

TOUCH the LOWER TAB key.

TYPE the text to be indented.

.....

USING THE NON-RECORDABLE FORMAT PAGE

The second page in the Format Block is the Non-Recordable Format Page (see Illustration VII-14 on Page 23).

The first page of format options is recorded with your document. The second page, however, is not recorded.

This second page gives you reformatting and paginating capabilities, editing options, and allows you to change the appearance of the screen.

- Instead of looking at a white screen, you can be looking at a dark screen.
- You can tell the system to display all the codes (center codes, regular carrier returns, required carrier returns, etc.) while you're typing.
- All characters can be zoomed on every line, instead of just the line of typing.

In the next exercise, you'll begin a new document and change the appearance of the screen before you type the document. Once you change the screen options, they will stay that way until the 860 is turned off, or you change them again.

Creating a New Document

Step 1 CREATE a new document titled **Will.**

Before changing the appearance of the screen, you'll change the margins, tabs, and line spacing.

Step 2 **TOUCH** the FORMAT key and change the margins using the following steps:

- Type **20**
- Touch CHAR and type **85**

SET the tabs using the following steps:

- Touch LINE to highlight TABS / SPEC TABS
- Type **25**
- Touch the LOWER TAB key
- Type **30**
- Touch the LOWER TAB key

CHANGE line spacing to double using the following steps:

- Touch LINE to highlight LINE SPACING.
- Use CHAR or RVRSE + CHAR until **2** is highlighted.

Calling Up the Non-Recordable Format Page

Step 3 **TOUCH** the FORMAT key a second time.

Result The Non-Recordable Format Page is displayed (see Illustration VII-14 on Page 23).

LOOK at the Non-Recordable Format Page on your screen.

Selecting the Code Display Option

The options with square boxes after them are turned on and off by touching the CHAR key. Touching CHAR fills in the box indicating that option is on (activated), or empties the box indicating that option is off (deactivated).

- Step 4**
- | | |
|---------------|--|
| TOUCH | the PARA and LINE keys until CODE DISPLAY is highlighted. (CODE DISPLAY is near the bottom of the page.) |
| TOUCH | the CHAR key to turn on CODE DISPLAY. |
| Result | The square box after CODE DISPLAY is filled in. When you type the document, all the codes will show on the screen. However, they will not print. |

Selecting the Dark Screen Option

DARK SCREEN reverses the way the screen appears. Instead of black characters on white (like a piece of paper), you can tell the system to display white characters against a black screen. To see how this works, follow the steps below.

- Step 5**
- | | |
|---------------|--|
| TOUCH | RVRSE and LINE to highlight DARK SCREEN. |
| TOUCH | the CHAR key to turn on this option. |
| Result | Instantly, the screen reverses. The Format Page is now displayed as white characters against a black background. |
| LOOK | at your screen to see if you like DARK SCREEN. |
| TOUCH | CHAR again to turn off the feature. |

Remember, turning on CODE DISPLAY and DARK SCREEN have no effect on the document. They are screen options and do not record.

NON-RECORDABLE FORMAT PAGE

REFORMAT OPTIONS

REFORMAT

- UNATTENDED
- REPLACE MARGINS
- REPLACE TABS
- REPLACE LINE SPACING
- REPLACE JUSTIFY
- REPLACE PITCH
- REPLACE KB/PW
- REPLACE PRINT WHEEL ID
- DELETE REVISION MARKS

PAGINATION OPTIONS

- PAGINATE
- UNATTENDED
- REPLACE PAGE LAYOUT
- REPLACE PAGE LABELS

PAGE LIMIT 1

EDIT OPTIONS

- EDIT REFORMAT
- UNATTENDED
- AUTO CARRIER RETURN
- AUTO PAGING
- MARGIN ZONE
- SPACE SIZE 3 5 7

DISPLAY OPTIONS

- ZOOM LINE
- ZOOM SCREEN
- SPLIT LINE
- DARK SCREEN
- CODE DISPLAY
- HORIZONTAL SCROLL 40

The Non-Recordable Format Page
Illustration VII-14

Lesson Seven--FORMAT I

You have changed the margins, tabs, and line spacing (which will record with the document), and have made some changes to the screen (which will not record with the document). Now, you'll record the format and type the document.

Step 6 **TOUCH** the ACCPT key.

Result The format is recorded in the document and the first page of the new document now displays all of the codes.

In this exercise, you will be using both the UPPER and LOWER TAB keys and numbering the paragraphs. Illustration VII-15 on the opposite page shows the document with a picture of which tab key to use as you type. (The tab key symbols will look different on your screen.)



Step 7 **TYPE** the document (see Illustration VII-15 on the next page), using the steps below:



- For initial indents (the first and last paragraphs), touch the UPPER TAB key at the beginning of the paragraph.
- For block indents (the numbered paragraphs), touch the LOWER TAB key, type the number, and touch the LOWER TAB key again.
- Let the system return the carrier except at the end of paragraphs.



END the document with a carrier return.

WILL

 I give, devise and bequeath all of the rest and residue of my estate, both real and personal, to my wife, to be held, administered and distributed in accordance with the following provisions:

 1.  The trustee is authorized to retain in the trust any property received by it hereunder, including shares of the trustee's own stock as long as the trustee considers that such retention is in the best interests of the trust.

 2.  The trustee shall have the power to sell, convey, exchange, improve, convert, repair, manage, operate and control all of the above property.

 3.  The trustee shall have the power to loan its funds to the trust for any and all purposes.

 The foregoing document, consisting of thirty pages, was duly signed and witnessed by the following named persons on this date.

Step 8 **LOOK** at the screen when you have finished typing and compare the symbols to those shown below.

With CODE DISPLAY activated, you can see the different types of carrier returns and tab keys on the screen. The codes you see on the screen are explained below:

A **Non-Required Return** (↵) is inserted by the system automatically when you're typing and get close to the right margin.

The system may, after you make revisions, convert this regular return to a space as it rearranges line lengths.

A **Required Return** (⏎) is entered when you return the carrier from the keyboard.

The system will never convert this return to a space. It is permanent and the system will always return at this point.

The **Upper Tab Key** (⇶) tells the system to indent only the first line of the paragraph.

The **Lower Tab Key** (→) instructs the system to automatically indent all lines of a paragraph.

Changing the Non-Recordable Format Page

The options on the Non-Recordable Format Page are not recorded with a document, and they don't change when you store and recall different documents. Use the steps below to turn off CODE DISPLAY.

Step 3 **TOUCH** the FORMAT key twice.

TURN OFF CODE DISPLAY using the following steps:

- Use LINE to highlight CODE DISPLAY
- Touch CHAR to turn off this option.

Since you did not change the recordable format settings, you do not need to touch ACCPT to record the format. Touching STOP will remove the Format Page from the screen without recording a new Format Block.

- Step 10 TOUCH** the STOP key twice to remove the Format Page from the screen. (Once to move highlighting from the CODE DISPLAY line. The second time to remove the Format Page.)
- Result** The Format Page is removed without being recorded.
- Step 11 TOUCH** the STORE key and ACCPT.
- Step 12 PRINT** the document.
- COMPARE** your printed copy with the one in Illustration VII-16 on page 7 - 28.

WILL

I give, devise and bequeath all of the rest and residue of my estate, both real and personal, to my wife, to be held, administered and distributed in accordance with the following provisions:

1. The trustee is authorized to retain in the trust any property received by it hereunder, including shares of the trustee's own stock as long as the trustee considers that such retention is in the best interests of the trust.
2. The trustee shall have the power to sell, convey, exchange, improve, convert, repair, manage, operate and control all of the above property.
3. The trustee shall have the power to loan its funds to the trust for any and all purposes.

The foregoing document, consisting of thirty pages, was duly signed and witnessed by the following named persons on this date.

USING MORE THAN ONE FORMAT

Some documents you type may require more than one format. With the 860, you can record as many formats within a document as you need. This gives you the flexibility to create documents with many different layouts. The next exercise uses more than one format.

Format Blocks should be recorded at the left margin, to ensure that the new format affects the entire line of text. In order to see all the format blocks within the document, you'll turn on the CODE DISPLAY option when you change the first format.

- Step 1** **CREATE** a new document titled **MULTI FORMATS**.
- Step 2** **TOUCH** the **FORMAT** key and set the following format:
- Margins at 17 and 79
 - Tab at 22
- TOUCH** the **FORMAT** key again and turn on **CODE DISPLAY**.
- TOUCH** the **ACCPT** key to record the Format Block.

- Step 3** **TYPE** the centered the heading shown in Illustration VII-19 below.
- TYPE** the first paragraph and touch the RETURN key twice.

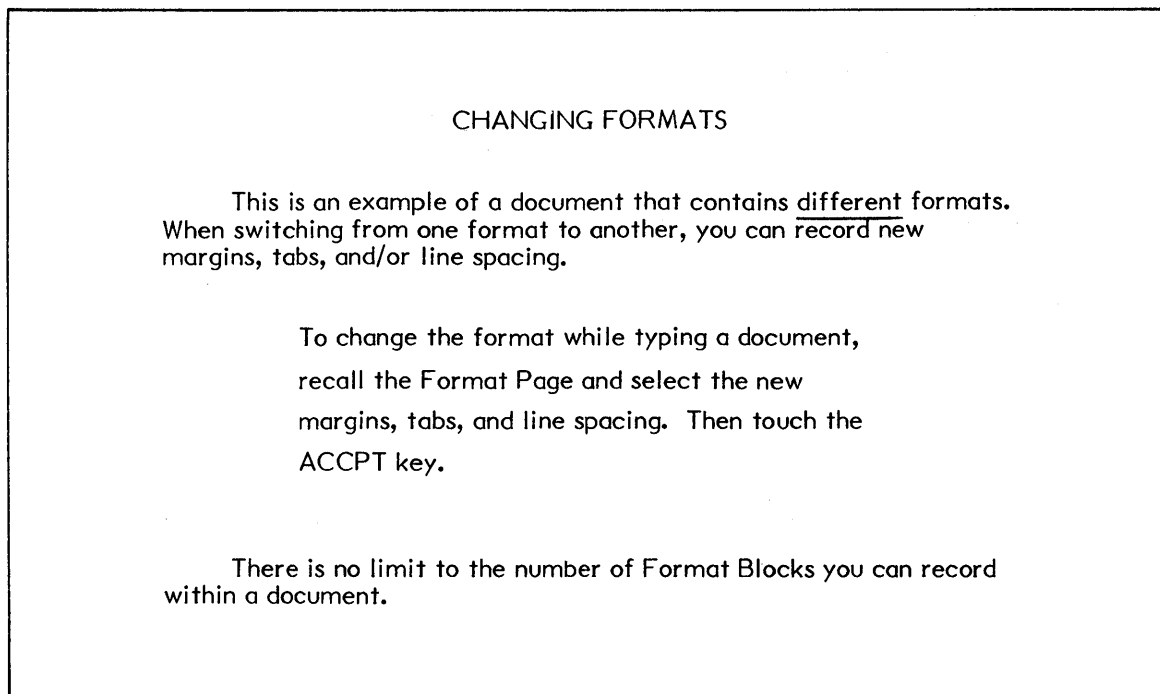

*Text for the Document **MULTI FORMATS**
Illustration VII-19*

Setting a Second Format on the Page

Now it is time to record the format for the second paragraph of the document. You will change the margins and line spacing to create a different layout. You'll also delete the tab setting by highlighting the TABS / SPEC TABS line and touching DEL.

- Step 4** **TOUCH** the FORMAT key and set new margins at 27 and 69.
- DELETE** the tab setting using the following steps:
- Use LINE to highlight TABS / SPEC TABS
 - Touch the DEL key
- CHANGE** the line spacing to one-and-a-half (1½).
- TOUCH** the ACCPT key to record the Format Block and touch the RETURN key once.
- Result** New margins and line spacing have been recorded.
- LOOK** at the screen to see the Format Blocks. Because CODE DISPLAY is turned on, you can see the Format Blocks on the page.
- Step 5** **TYPE** the second paragraph (since you changed the margins to indent the paragraph, it is not necessary to use the tab key). Touch the RETURN key twice at the end of the paragraph.

Setting a Third Format on the Page

- Step 6** **TOUCH** the FORMAT key and set the following format:
- Margins at 17 and 79
 - Tab at 22
 - Single line spacing (1)
- TOUCH** the ACCPT key to record the Format Block and the RETURN key once.
- Step 7** **TYPE** the rest of the document.
- END** with a carrier return.
- Step 8** **STORE** the document.

Printing Out Copies With Codes

You've seen the codes displayed on the screen. You can also print the codes on paper. A "code print" copy of a document tells you exactly how it was recorded, what margins and tabs were used, and which tab keys were used. You may want to keep code print copies of documents you use often. Use the instructions that follow to print a code print copy of **MULTI FORMATS**.

- Step 1**
- TOUCH** PAGE to highlight the INDEX of your Student Disc.
 - HIGHLIGHT** the document titled **MULTI FORMATS**.
 - HOLD** down CODE and touch 7.
 - Result** The Print Options are displayed (see Illustration VII-17 below).
 - LOOK** at the Print Options on your screen and find CODE PRINT.
- Step 2**
- TOUCH** LINE to highlight CODE PRINT.
 - TOUCH** the CHAR key to turn on this option.
 - TOUCH** the ACCPT key.

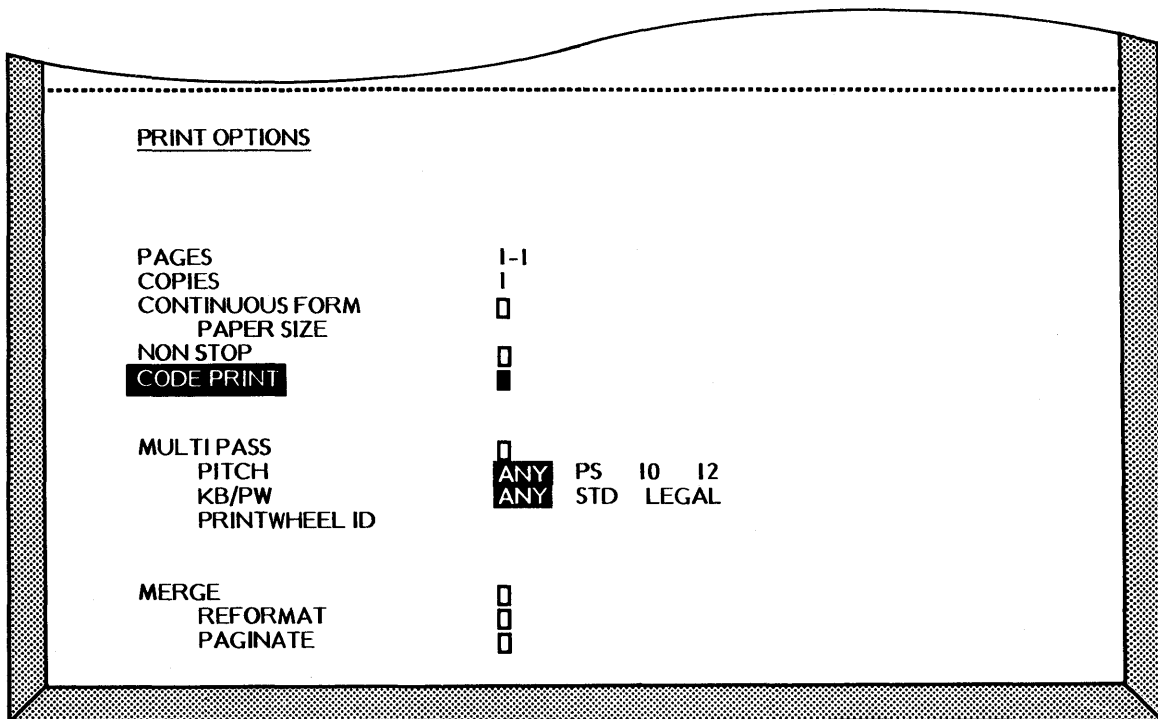

The Print Options Page with CODE PRINT Highlighted
Illustration VII-17

- Step 3 CHECK** that paper is in the printer, then start the printer.
- Result** The document title and the recorded format information print out first. The document prints showing the upper tab and required carrier returns as hyphens with a slash through them (/). You can tell a required carrier return from an upper tab key by its position in the document.
- Step 4 COMPARE** your printed copy against the one shown in Illustration VII-20 below. It should be similar.

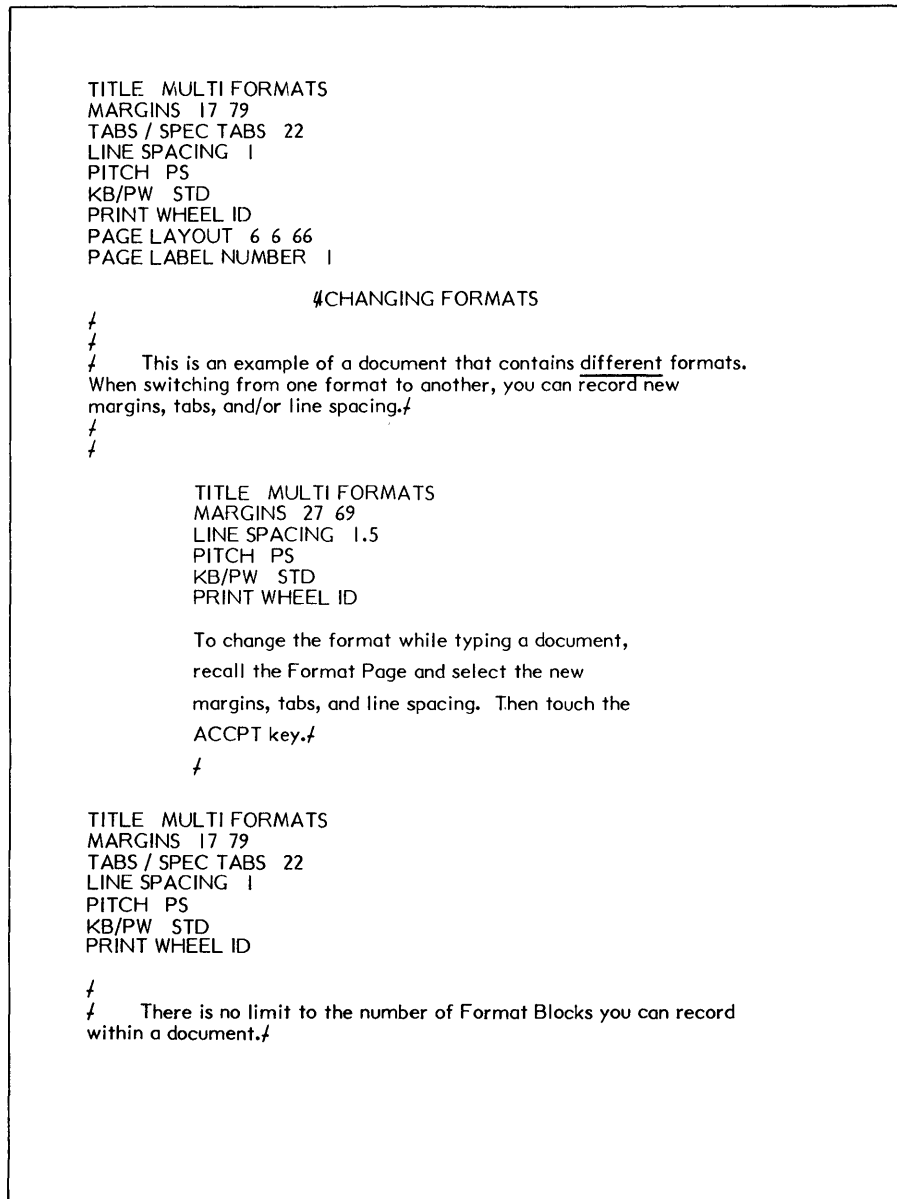

Printed Version (with Codes) of the Document **MULTI FORMATS**
Illustration VII-20

REVIEW OF
USING MULTIPLE FORMATS, SCREEN OPTIONS, AND CODE PRINT

This page is a review of the procedures you've learned in this part of the lesson. Read through the procedures to make sure you understand them. Then go on with the lesson.

To use more than one Format Block on a page:

- SET** the format at the beginning of the document.
- TYPE** text, ending with a return.
- TOUCH** the FORMAT key.
- SET** new margins, tabs, etc.
- TOUCH** the ACCPT key.
- CONTINUE** to set as many new Format Blocks as necessary.

To change an option on the Non-Recordable Format Page:

- BRING** the document to the screen.
- TOUCH** the FORMAT key twice.
- HIGHLIGHT** the selected option (use the LINE key).
- TOUCH** the CHAR key to turn the option on or off.

To print a document with codes:

- HIGHLIGHT** the document title.
- TOUCH** CODE + 7.
- HIGHLIGHT** CODE PRINT. (use the LINE key).
- TOUCH** the CHAR key to turn on this option.
- TOUCH** the ACCPT key.
- PRINT** the document.

USING REFORMAT

After typing a document, you can tell the 860 to rearrange the line endings to make them even, or right-justified (like this manual).

When the system (reformats) rearranges the lines, some words are moved down or up a line to give you a tighter right margin. Sometimes the system will ask for your help in hyphenating long words in order to rearrange the text.

The reformatting shows on the screen, so you can watch the system rearrange the document. If the system needs your help with a long word, it will stop and highlight the word that requires hyphenation.

Follow the steps below to reformat a document. Your Student Disc has a prerecorded document with several hyphenation decisions.

- | | | |
|---------------|------------------|---|
| Step 1 | RECALL | DOC A to the screen. This document contains several long words which may require hyphenating. |
| Step 2 | TOUCH | the FORMAT key twice. |
| | Result | The Non-Recordable Format Page is brought to the screen and REFORMAT is highlighted. |
| | TOUCH | the CHAR key to turn on REFORMAT . |
| | HIGHLIGHT | CODE DISPLAY and turn off the option by touching CHAR . |
| | TOUCH | the ACCPT key to begin reformatting. |
| | Result | The system goes through the document and highlights the first word where you must make a hyphenation decision. In this case, the system asks for your help in hyphenating the word "nonresponsiveness." |

Reformatting and Hyphenating

When the system asks for a hyphenation decision on a long word, you have two choices:

- Tell the system not to hyphenate the word, or
- Tell the system where to hyphenate the word.

During reformat, the system quickly displays the document a line at a time. When a long word needs to be hyphenated, the system stops and displays the word for you to make a decision. The system highlights an area within the word. The flashing character indicates how much of the word will fit on the line before the right margin. You can hyphenate the word within the highlighted area, or extend the highlighting to the right or left by touching CHAR or RVRSE plus CHAR.

If you decide to hyphenate the word, you touch the HYPHEN key (see Illustration VII-21 below) and a hyphen will be placed in front of the flashing character.

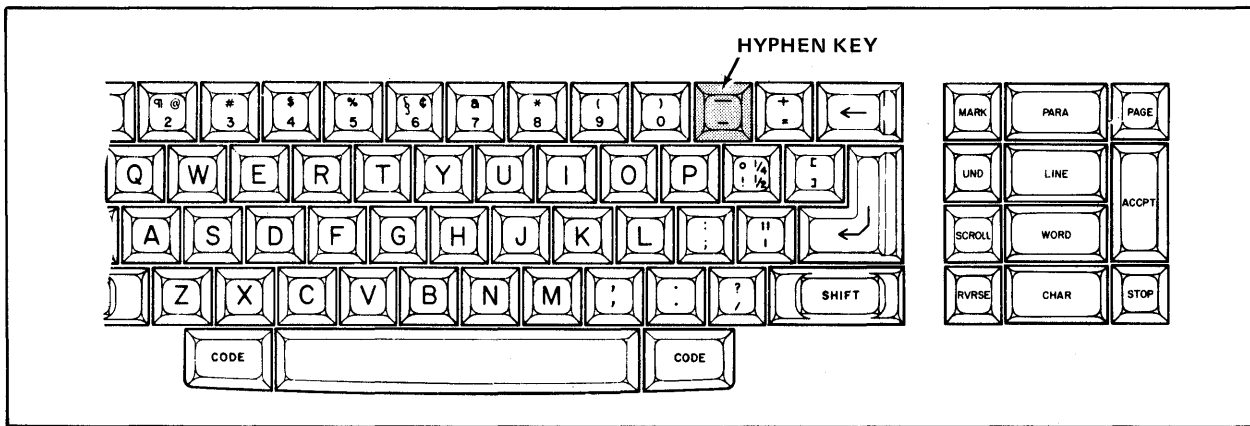

The HYPHEN Key
Illustration VII-21

If you decide not to hyphenate the word, you touch the ACCPT key. This tells the system to put the entire word on the next line.

Sometimes the system may ask you to hyphenate a word that cannot be hyphenated (like the word "through"). If this happens, you touch the ACCPT key to tell the system to move the word to the next line.

Step 3 **HYPHENATE** the word **nonresponsiveness** as **nonre-sponsiveness** by using these steps:

- Hold down the RVRSE key
- Touch CHAR until the **s** is flashing
- Touch the HYPHEN key

Result The 860 places a hyphen in front of the **s**, moves the rest of the word to the next line and rearranges the rest of the page. Then the highlighting moves to the next decision point.

Step 4 **HYPHENATE** the word **instrumentalities** as **instru-mentalities**:

- Since the **m** is already flashing,
- Touch the HYPHEN key

Step 5 **HYPHENATE** **departmentalized** as **department-alized**:

- Hold down the RVRSE key
- Touch the CHAR key until the letter **a** is flashing
- Touch the HYPHEN key

Step 6 **TOUCH** the ACCPT key to move the word **infrastructure** to the next line instead of hyphenating it.

Step 7 **HYPHENATE** **progressive** into **progres-sive**:

- Touch the HYPHEN key

Continue with the instructions on the next page.

Step 8 **HYPHENATE** the remaining words (**require-ments** and **commit-tees**):

- Touch RVRSE + CHAR or CHAR until the suitable letter is flashing. Then touch the HYPHEN key.

COMPARE the final version on the screen with Illustration VII-22 below.

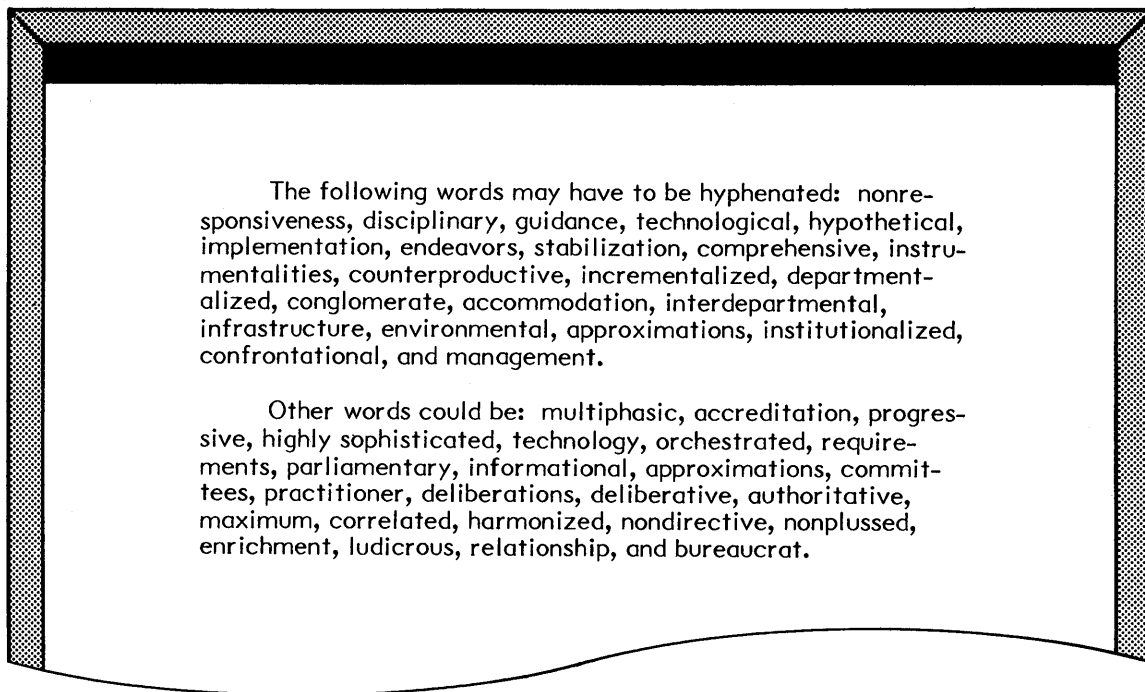

*Screen Version of the Reformatted Document DOC A
Illustration VII-22*

- Step 9 STORE** the revised document under a new title: **FINAL HYPHEN**, using the following steps:
- Touch the STORE key
 - Touch the ACCPT key
 - Type the new title, **FINAL HYPHEN**
 - Touch the ACCPT key
- Result** The revised version (the document with the hyphens) and the original are both stored on the disc.

- Step 10 PRINT** the document.

Note: The document you just reformatted contained several hyphenation decisions for practice. In your normal work, you won't see as many hyphenation decisions. The document was designed to help you learn how to hyphenate words.

When you hyphenate a word during reformat, the 860 will always keep the hyphen in the word. If you revise the document again so that the word no longer comes at the end of a line, the 860 will make the hyphen "invisible" and close up the word. (However, you can look at the hyphen by highlighting the word.)

Keeping the Word on the Line

If you want to keep the word on the same line without hyphenating it, you can use the CHAR key to move the highlighting through the word. When you highlight the carrier return after the word, the 860 will leave the word on the line and go on with the reformat.

Splitting Compound Words

The system may ask for help in hyphenating a compound word, like **electrical/mechanical** or **black/white**. Since a hyphen would be incorrect in either of these cases, you wouldn't want to hyphenate the word. However, it would be proper to insert a carrier return after the slash (/), without a hyphen. To do this, use CHAR or RVRSE and CHAR to move the flashing character past the slash, then touch the RETURN key.

When you touch the return key during a reformat, the system will split the word with a non-required return. If you reformat the document again, the system will drop the return and close up the compound word.

JUSTIFYING THE MARGINS

When you look at newspapers, magazines, and even this manual, you are looking at justified text. This means the left and right margins are even. Now that you know how to reformat a document, justifying is a very simple matter.

The 860 justifies your documents by making the spaces between the words larger or smaller to even out every line. Without justification, every space is exactly the same size. With justification, the spaces between the words vary in width.

Step 1 **RECALL** the document titled **DOC A**.

Selecting the JUSTIFY Option

In order to tell the system you want to justify this document, you turn on the JUSTIFY option.

Step 2 **TOUCH** the **FORMAT** key once.

Result The Recordable Format Page is brought to the screen.

TOUCH the **LINE** key until **JUSTIFY** is highlighted.

TOUCH the **CHAR** key to fill in the box and turn on this option.

Selecting the Reformat Option

Turning on JUSTIFY alone is not enough. You must tell the system to REFORMAT the document so that it can rearrange the lines in order to justify correctly.

- Step 3** **TOUCH** the FORMAT key again to bring up the second format page.
- ACTIVATE** REFORMAT by touching the CHAR key.
- Result The system is ready to reformat and justify the document.
- Step 4** **TOUCH** the ACCPT key to record the format and start the reformatting.
- Result Reformatting begins.

Making Hyphenation Decisions for Justified Text

Making hyphenation decisions for justified text is very similar to making hyphenation decisions for non-justified text. The only difference is that you cannot move the flashing character to the right of the highlighted area. The reason for this is that justified text cannot exceed the right margin.

- Step 5** **MAKE** the necessary hyphenation decisions using the following steps:
- To hyphenate the word:
Touch RVRSE + CHAR until correct character is flashing. Then touch the HYPHEN key.
 - If you don't want to (or cannot) hyphenate a word:
Touch the ACCPT key.
- Step 6** **STORE** this revision under the title **JUSTIFY** using the following steps:
- Touch STORE and ACCPT
 - Type **JUSTIFY** and ACCPT again

Lesson Seven--FORMAT I

Step 7 PRINT the revised document.

Step 8 COMPARE your printed copy with the one in Illustration VII-23 below.

The following words may have to be hyphenated: nonresponsiveness, disciplinary, guidance, technological, hypothetical, implementation, endeavors, stabilization, comprehensive, instrumentalities, counterproductive, incrementalized, departmentalized, conglomerate, accommodation, interdepartmental, infrastructure, environmental, approximations, institutionalized, confrontational, and management.

Other words could be: multiphasic, accreditation, progressive, highly sophisticated, technology, orchestrated, requirements, parliamentary, informational, approximations, committees, practitioner, deliberations, deliberative, authoritative, maximum, correlated, harmonized, nondirective, nonplussed, enrichment, ludicrous, relationship, and bureaucrat.

*Printed Version of the Document DOC A (with Right Justification)
Illustration VII-23.*

.....

**REVIEW OF
USING REFORMAT**

This page is a review of the procedures you've learned in this part of the lesson. Read through the procedures to make sure you understand them. Then go on with the lesson.

To justify the margins:

- TOUCH** the FORMAT key.
- HIGHLIGHT** the JUSTIFY line and touch CHAR to turn it on.
- TOUCH** FORMAT again and reformat the document.

To reformat a document:

- TOUCH** the FORMAT key twice.
- TOUCH** the CHAR key to turn the Reformat option on.
- TOUCH** the ACCPT key to begin reformatting.

If you are able to hyphenate the word:

- TOUCH** the CHAR key (or RVRSE + CHAR keys) to select the letter you want the hyphen to precede.
- TOUCH** the HYPHEN key to insert a hyphen and divide the word.

If you are not able to hyphenate the word:

- TOUCH** the ACCPT key to move the word to the next line.

To split a compound word:

- SELECT** the letter after the slash (use the CHAR key).
 - TOUCH** the RETURN key to insert a carrier return.
-

PRACTICE EXERCISE

In this practice exercise, you will recall the document titled **SOURCES**, turn on **JUSTIFY** and reformat the document. Then you will store the reformatted document under a new title.

- Step 1** **RECALL** the document titled **SOURCES**.
- Step 2** **TOUCH** the **FORMAT** key and turn on **JUSTIFY**.
- TOUCH** the **FORMAT** key again and turn on **REFORMAT**.
- TOUCH** the **ACCPT** key.
- Step 3** **HYPHENATE** (if necessary) using these steps:
- To hyphenate the word:
 Touch **RVRSE + CHAR** until a suitable character is flashing. Then, touch the **HYPHEN** key.
 - If you don't want to (or cannot) hyphenate the word:
 Touch the **ACCPT** key.
- Step 4** **STORE** the document under the title **Practice 7**.
- Step 5** **PRINT** the document.

You have now completed Lesson Seven. On the next pages there are Points to Remember and an Action Summary for you to review.

There is also a Progress Check for you to complete. If you should answer any of the questions incorrectly, turn to the page indicated in the answer and review the information.

POINTS TO REMEMBER

- Every document has its own margins, tabs, and line spacing which are recorded with the document. (Page 7-8)
- Each time you start a new document, it will have the standard settings in the format block. (Page 7-3)
- To change the margins, highlight the MARGINS line and type the new settings. (Page 7-6)
- To set a tab, highlight the TABS / SPEC TABS line, type the setting, and touch the LOWER TAB key. (Page 7-7)
- Touch the ACCPT key to record the Format. (Page 7-8)
- When typing text, the LOWER TAB key instructs the system to indent all the lines of a paragraph. (Page 7-10)
- When typing text, the UPPER TAB key tells the system to indent only the first line of a paragraph. (Page 7-14)
- Screen options are not recorded with the Format. (Page 7-20)
- Format Blocks should be recorded at the left margin to ensure that the new format affects the entire line of text. (Page 7-29)
- To delete previously set tabs, highlight the TABS / SPEC TABS line and touch the DEL key. (Page 7-30)
- During a REFORMAT:
 - Use CHAR or RVRSE + CHAR to select a proper hyphenation point and touch the hyphen key; **or**
 - Touch the ACCPT key to tell the system to put the entire word on the next line; **or**
 - If the document is not justified, use CHAR to highlight the carrier return at the end of the line to leave the word on the line; **or**
 - Use CHAR to move the highlighting to the correct position in a compound word and touch RETURN.

ACTION SUMMARY

You may want to make a copy of this ACTION SUMMARY and keep it on your desk for quick reference.

The margins, tabs, etc. for a document are recorded in the Format Block. Each document must begin with a Format Block. You can change the settings in the Format Block to change the format of the documents. You can record other Format Blocks in the document to change the format in the middle of the document.

To record a new format:

- Step 1 RECALL** the document to the screen.
- Step 2 TOUCH** the FORMAT key.
- SET** new margins:
- Type the left margin setting
 - Touch CHAR
 - Type the right margin setting
- SET** new tabs:
- Touch LINE to highlight the TABS / SPEC TABS line
 - Touch DEL if you want to delete old tab settings
 - Type the first tab position number
 - Touch the LOWER TAB key
 - Continue to type each tab number and touch the LOWER TAB key until all tabs are set
- CHANGE** the line spacing:
- Touch LINE to highlight the LINE SPACING line
 - Touch CHAR to highlight the desired line spacing
- SELECT** JUSTIFY if desired, by highlighting JUSTIFY and touching CHAR.
- Step 3 TOUCH** ACCPT to record the format.

To change the format in the middle of a document:

- Step 1 TYPE** the text up to the point of the format change.
- TYPE** a carrier return.
- Step 2 TOUCH** FORMAT and use the steps above to change the margins, tabs or line spacing.
- TOUCH** ACCPT to record the format.

ACTION SUMMARY -- CONTINUED

The 860 has two tabs keys. The UPPER TAB key is used to indent only the first line of a paragraph (initial indent), and the LOWER TAB key is used to indent all lines of a paragraph (block indent).

To use the tab keys:

- Step 1 RECALL** the document to the screen.
- Step 2 TOUCH** the FORMAT key and set tabs in the format.
TOUCH ACCPT to record the format
- Step 3 INDENT** only the first line of a paragraph, using the following steps:
- Touch the UPPER TAB key at the beginning of the paragraph
 - Type the paragraph
 - End with a carrier return
- INDENT** all lines of a paragraph, using the following steps:
- Touch the LOWER TAB key at the beginning of the paragraph
 - Type the paragraph
 - End with a carrier return
- Step 4 STORE** the document when you're finished.

ACTION SUMMARY -- CONTINUED

Documents can be reformatted to make the right margin more even. When you reformat, the 860 will ask you to make hyphenation decisions if a word is too long to fit within the margins.

To reformat a document:

- Step 1** **RECALL** the document to the screen.
- Step 2** **TOUCH** **FORMAT** once.
- TURN ON** **JUSTIFY**, if you want the right margin justified.
- Step 3** **TOUCH** **FORMAT** again.
- TOUCH** **CHAR** to turn on the **REFORMAT** option.
- Step 4** **TOUCH** **ACCPT** to start the reformat.
- MAKE** any hyphenation decisions using one of the following methods:
- Touch **RVRSE + CHAR** or **CHAR** to select the position for the hyphen (the hyphen will go in front of the flashing character)
 - Touch the hyphen key
 - OR**
 - Touch **ACCPT** to put the word on the next line without hyphenating it
 - OR**
 - Touch **RVRSE + CHAR** or **CHAR** to select the position for splitting a compound word
 - Touch the **RETURN** key to split the word without hyphenating it
 - OR**
 - Touch **CHAR** to move the highlighting through the entire word to keep it on the same line (if **JUSTIFY** is not selected)
- Step 5** **STORE** the document.

PROGRESS CHECK

Part I

1. Type the document shown in Illustration VII-24 on the opposite page. Use the title, **PROGRESS 3**.

Use the following format for the first and third paragraphs:

Margins of 17 and 79
Tab of 22
Double Spacing
Justify turned **on**

Use this format for the second paragraph:

Margins of 27 and 67
Single Spacing
Justify turned **on**

2. When you're finished typing, touch the STOP key twice, then REFORMAT the document.
3. Store and print the document.

Your printed copy should be similar to the example in Illustration VII-25 on Page 7-52.

Justify right margin

MODERN PRINTING PRESSES

Gold

The modern job, or platen, press is the direct descendant of a machine perfected in 1858 by George P. Gordon of New York.

In this machine the platen and form are turned on edge. Of the models manufactured today, some employ a rigid bed, with the platen drawn up against the form.

The modern cylinder press was first conceived by William Nicholson of London. He secured patents in 1790 but was unable to perfect a model that worked.

Text for the Document **PROGRESS 3**
Illustration VII-24

MODERN PRINTING PRESSES

The modern job, or platen, press is the direct descendant of a machine perfected in 1858 by George P. Gordon of New York.

In this machine the platen and form are turned on edge. Of the models manufactured today, some employ a rigid bed, with the platen drawn up against the form.

The modern cylinder press was first conceived by William Nicholson of London. He secured patents in 1790 but was unable to perfect a model that worked.

*Print Version of the Document **PROGRESS 3**
Illustration VII-25*

Part II

Answer each question by filling in the blank with the correct answer, then compare your answers with those on Page 7 - 55.

1. If tabs are set, you can indent blocks of text by touching the _____ key before the text to be indented.

2. To indent only the first line of a paragraph, you use the _____ key.

3. To change the display screen to a dark screen, you recall the _____ Format Page, highlight the _____ option, and touch the _____ key to activate the option.

4. You can print a document with all codes showing by selecting the _____ option on the Print Options page before starting the printer.

(This page is intentionally left blank.)

ANSWERS TO PROGRESS CHECK -- Part II

If you are uncertain or answered a question incorrectly, refer to the pages listed on this answer form to review the original material. When you feel comfortable with the material, return to this point in the lesson and continue.

1. If tabs are set, you can indent blocks of text by touching the Lower
Tab key before the text to be indented. (Page 7-10)
2. To indent only the first line of a paragraph, you use the Upper
Tab key. (Page 7-14)
3. To change the display screen to a dark screen, you recall the Non-
Recordable Format Page, highlight the Dark Screen
option, and touch the CHAR key to activate the option. (Page 7-22)
4. You can print a document with all codes showing by selecting the Code
Print option on the Print Options page before starting the printer. (Page
7-32)

Lesson Seven--FORMAT I

(This page is intentionally left blank.)

Xerox 860 IPS Operator Manual
Book One: Fundamentals

Lesson Eight – Utilities
Using the Utilities

LESSON EIGHT

UTILITIES

Using the System Utilities

OBJECTIVES

After finishing this lesson you will be able to:

- move from the Activity Page to the System Disc Page
 - use the Utility Selection Page
 - identify the purpose of the utilities
 - use the BACKUP INDEX to recover or permanently delete documents
 - use the INITIALIZE utility to prepare a disc for use in the 860
 - use the DUPLICATE utility to make an exact copy of a disc
-

Materials Needed

For this lesson you will need:

- System Disc
- Student Disc
- Training Disc
- Reference Manual
- Optional: a new (unused) disc

BEFORE YOU BEGIN

Check to be sure your 860 is set up as follows:

- System ON.
- ACTIVITY PAGE on screen.
- Student Disc in left disc station.
- System Disc in right disc station.

If your 860 is set up correctly, the screen should look like Illustration VIII-1 below.

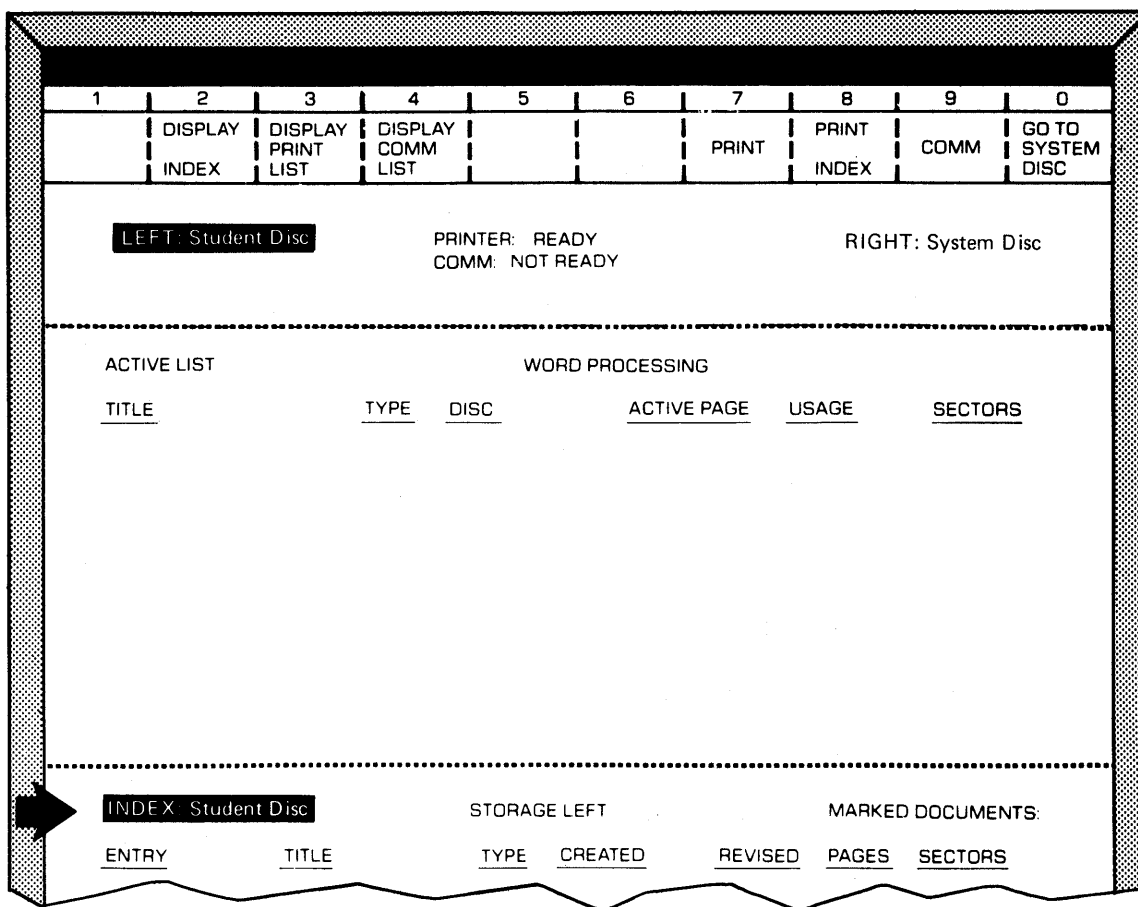

The Activity Page
Illustration VIII-1

THE UTILITY SELECTION PAGE

The utilities are software features that are used less frequently than Word Processing. You learned earlier that a deleted document is put in the Backup Index. The Backup Index is a utility. In this lesson, you'll learn to retrieve a document from the Backup Index.

In addition to the Backup Index, the 860 has other utilities. You'll learn the purpose of each of them, so you will know when to use them in your work.

Each utility is a separate piece of software on the System Disc. When you use a utility, the System Disc must be in the 860 so it can load the utility software. To select a utility, you'll return to the System Disc Page (the page you use to load the Word Processing software). Then you'll bring up the Utility Selection Page and select the utility you want.

Returning to the System Disc Page

Step 1 **LOOK** at the instruction blocks at the top of the Activity Page. Notice that the block below the "0" says GO TO SYSTEM DISC. You'll use this instruction to go to the System Disc Page.

Step 2 **HOLD** down CODE and touch the 0 (zero) key.

Result The Command Line displays:

LOADING -- PLEASE WAIT

Then the System Disc Page is brought to the screen, and the Command Line displays:

SELECT OPTION

Bringing the Utility Selection Page to the Screen

Step 3 **TOUCH** the PAGE key to bring the Utility Selection Page to the screen (see Illustration VII-1 on Page 8-5).

Result A page titled UTILITY SELECTION is brought to the screen and the Command Line displays:

SELECT UTILITY

Lesson Eight--UTILITIES

You select the utility you wish to use by highlighting it with the LINE or RVRSE + LINE keys and touching ACCPT. The selected utility software will then be loaded into the 860's memory.

There are seven utilities listed on the Utility Selection Page (See Illustration VIII-2 on the next page). Below is a brief description of the purpose of each:

Initialize - This utility prepares new discs for use in the 860. It also checks the disc for damaged or "flawed" sectors.

Duplicate - This utility makes an exact copy of a disc.

Reconstruct - This utility rebuilds an Index on your disc when there have been disc errors in the Index.

Rename - This utility allows you to give a disc a new name.

Backup Index - This utility allows you to recover deleted documents and to permanently delete documents.

Convert - This utility converts documents from an 850 disc to an 860 disc, or vice versa.

Recover - This utility allows you to recover a document if your system is turned off or loses power before the document is stored.

Switching Between Pages

You can use the PAGE key to switch back and forth between the Utility Selection Page and the System Disc Page. Try this, using the steps below:

- | | | |
|---------------|--------------|---|
| Step 4 | TOUCH | the PAGE key. |
| | Result | The System Disc Page is displayed on the screen and Word Processing is highlighted. |
| | TOUCH | the PAGE key again. |
| | Result | The Utility Selection Page is returned to the screen. |

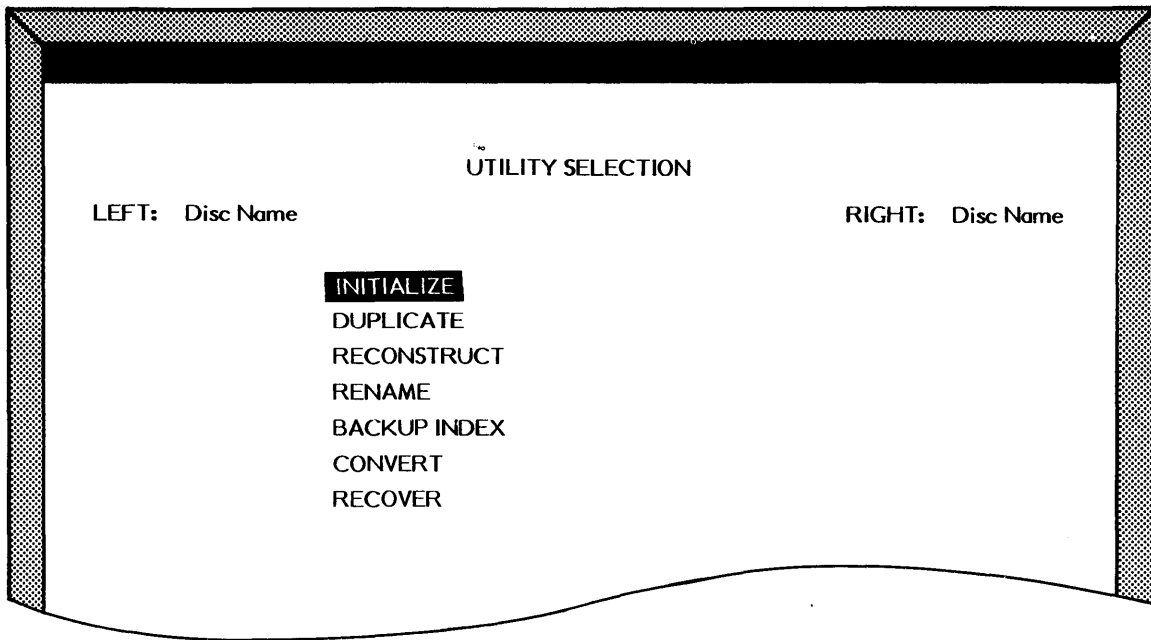

*The Utility Page
Illustration VIII-2*

THE BACKUP INDEX UTILITY

Earlier it was explained that any documents you deleted would automatically go to a Backup Index. The Backup Index gives you the ability to get back (recover) these documents or even an entire disc should you accidentally delete it.

The Backup Index contains:

- documents you deleted from the INDEX on the Activity Page
- the previous version of documents that were revised, when the revision was stored over the original.

In the next two exercises you'll be working with the Backup Index to recover a document you deleted from the INDEX on the Activity Page and to delete documents from the Backup Index.

Selecting BACKUP INDEX

To use the Backup Index, you highlight it and touch the ACCPT key. The 860 will then load the Backup Index software and bring the instructions for using the Backup Index to the screen.

Messages that guide you through using the Backup Index will be displayed in the Command Line.

Step 1 **HIGHLIGHT** BACKUP INDEX (use the LINE key).

TOUCH the ACCPT key.

Result The Command Line displays:

```
LOADING -- PLEASE WAIT
```

WAIT for the software to load. As soon as the Backup Index software has been loaded in memory, the Command Line displays:

```
BACKUP INDEX    PARA TO SELECT DISC STATION --  
ACCPT TO CONTINUE
```

The Backup Index is brought to the screen.

The instruction blocks appear below the Command Line. Notice that the only block that is filled in is the 0 - GO TO SYSTEM DISC block. This is the instruction you'll give when you are finished using this utility. Below the instruction blocks and the Status Line are instructions for using the Backup Index.

READ the instructions on your screen.

Selecting the Disc Station

You use the PARA key to select either the left or the right station. Since your Student Disc is in the left station, (and it's highlighted), you don't need to use the PARA key.

Step 2 **TOUCH** the ACCPT key.

Result The BACKUP INDEX for the Student Disc is displayed on the lower half of the page. It lists all deleted or revised documents and their original entry numbers.

The Command Line displays:

```
LINE TO SELECT TITLES
```

Recovering a Document from the Backup Index

In the next step you'll use LINE and MARK to select two of the deleted documents and put them back in the INDEX. This is called recovering a document.

Step 3 **HIGHLIGHT** the document **NAME** (use the LINE key).

Result The Command Line displays:

```
MARK TITLE -- ACCPT TO RECOVER --  
DEL TO DELETE
```

TOUCH the ACCPT key to recover the document.

Result The Command Line reads:

```
RECOVER DOCUMENTS -- ARE YOU SURE?
```

TOUCH the ACCPT key.

Result The Command Line displays:

```
RECOVERING -- NAME
```

When the 860 finishes putting the document back in the INDEX, the Command Line displays:

VERIFYING INDEX -- PLEASE WAIT

When it finishes verifying the Index, it displays:

RECOVERY COMPLETED -- ACCPT TO CONTINUE

Now the document has been recovered and is listed in the INDEX on the Activity Page. But the title is still shown on the Backup Index. Until you touch ACCPT to continue the recovery process or tell the system you're finished with the Backup Index, the title stays on the Backup Index.

Returning to the System Disc Page

The STOP key is used to tell the 860 you've finished using the Backup Index. Then the CODE + 0 (zero) keys are used to return the System Disc Page to the screen.

Step 5 TOUCH the STOP key.

Result The Command Line displays:

CODE + 0 TO EXIT -- ACCPT TO CONTINUE

HOLD down CODE and touch the 0 (zero) key to go back to the System Disc Page.

Result The Command Line displays:

LOADING -- PLEASE WAIT

Then the System Disc Page is brought to the screen and the Command Line displays:

SELECT OPTION

and WORD PROCESSING is highlighted.

Lesson Eight--UTILITIES

Returning to the Activity Page

Now you can load the Word Processing software and go back to the Activity Page to check that the recovered document called **NAME** has been placed in the INDEX.

Step 6 TOUCH ACCPT to load the software for Word Processing again.

Result The Command Line displays:

LOADING -- PLEASE WAIT

WAIT for the software to load. When the software is loaded, the Activity Page is displayed.

LOOK at the INDEX. **NAME** is the first document listed and it has a new entry number.

If you recover a document that has the same title as another document in the INDEX, the 860 will display the message **TITLE USED - COPY OVER IT?** If you touch **ACCPT**, the 860 will replace the document in the INDEX with the document you are recovering. When you see the **TITLE USED** message, it is best to type a new title for the recovered document and then touch **ACCPT**.

Deleting Documents from the Backup Index

The Backup Index is a great safety feature if you accidentally delete documents, but you may be wondering how you delete documents you really don't need or want anymore. You can permanently delete documents from the disc by deleting them from the INDEX and then from the Backup Index.

As every document takes up disc space, you'll need to delete documents from the Backup Index to "free up" disc space for creating and revising other documents. You won't need to use any of the documents listed on the Backup Index again, so you'll delete the entire Backup Index.

Before you begin, **write** down the number shown after the words STORAGE LEFT.

- Step 1** **TOUCH** CODE + 0 to go to the System Disc Page.
- TOUCH** the PAGE key to go to the Utility Selection Page.
- Step 2** **HIGHLIGHT** BACKUP INDEX.
- TOUCH** ACCPT to load the Backup Index software.
- WAIT** for the Backup Index instruction page to come to the screen.
- CHECK** that LEFT: Student Disc is highlighted. (If it is not, touch PARA.)
- TOUCH** the ACCPT key.
- CHECK** that the Backup Index for the Student Disc is displayed.
- TOUCH** the STOP key to be sure no titles are highlighted on the Backup Index.

Lesson Eight--UTILITIES

Step 3 **TOUCH** the DEL (Delete) key.

Result The Command Line displays:

```
DELETE DOCUMENTS -- ARE YOU SURE?
```

TOUCH **ACCPT.**

Result As the system deletes each title on the Backup Index, the Command Line displays:

```
DELETING -- document title
```

As soon as all titles have been deleted, the Command Line displays:

```
VERIFYING INDEX -- PLEASE WAIT
```

The 860 is checking the INDEX to be sure it is correct. After the 860 has verified the INDEX, the Command Line displays:

```
DELETE COMPLETED -- ACCPT TO CONTINUE
```

Step 4 **TOUCH** **ACCPT.**

Result The Backup Index is now blank and the STORAGE LEFT number has increased.

Step 5 **COMPARE** the new STORAGE LEFT number with the number you wrote down earlier to see how many sectors were recovered on your Student Disc.

The disc space taken up by the documents in the Backup Index has now been cleared for use. Remember, the Backup Index is your margin of safety if you accidentally delete documents. It's very easy to follow the messages in the Command Line to recover or delete documents from the Backup Index.

It's a good idea to check the Backup Index regularly and permanently delete all documents that you no longer need. Otherwise, your disc space will be filled up by unwanted documents.

Returning to the System Disc Page

At this point you could insert another disc, touch ACCPT and recover or delete documents from its Backup Index. When you are done using the Backup Index utility, you use CODE + 0 (zero) to return to the System Disc Page.

Step 6 **HOLD** down CODE and touch 0 to go back to the System Disc Page.

Result The Command Line displays:

LOADING -- PLEASE WAIT

When the software is loaded, the System Disc Page will return to the screen.

THE DISC DUPLICATE UTILITY

The Disc Duplicate utility makes an exact copy of a disc. As you recall, when you use the COPY key to copy documents from one disc to another, the copied documents are added to the other documents on the disc and nothing is erased. When you use the Disc Duplicate utility to copy one disc to another, it does erase any documents on the other disc.

Whenever you want an exact copy of a disc (sector by sector), use the Disc Duplicate utility. (Note: If you have double-sided discs, you cannot use the duplicate utility to duplicate documents to or from a single-sided disc. You must use the COPY key instead.)

In the steps that follow, you'll duplicate the Training Disc onto the Student Disc.

Selecting the Duplicate Utility

Step 1 **TOUCH** the PAGE key to bring the Utility Selection Page to the screen.

Step 2 **HIGHLIGHT** the DUPLICATE utility (use the LINE key).

TOUCH the ACCPT key.

Result The Command Line displays:

```
LOADING -- PLEASE WAIT
```

After the software has been loaded, an information page appears on the screen and the Command Line displays:

```
REMOVE SYSTEM DISC -- ACCPT TO CONTINUE
```

Step 3 **REMOVE** the System Disc.

TOUCH ACCPT.

When the software is loaded, the DUPLICATE utility comes to the screen.

READ the information on the screen.

Selecting Source and Destination Disc Stations

Notice that the Command Line displays the message PARA KEY TO SWITCH STATIONS --ACCPY TO CONTINUE.

Look at the top of the screen and find the words SOURCE and DESTINATION. This indicates that the SOURCE DISC (the disc with the information) should be placed in the left station, and the DESTINATION DISC (the disc you wish to duplicate to) should be placed in the right station. If you want to change the disc stations, you can touch the PARA key. For this exercise, you will change the disc stations.

Step 4 **TOUCH** the PARA key.

TOUCH the ACCPT key.

Result The Command Line now displays:

```
INSERT SOURCE DISC IN RIGHT STATION --
ACCPY TO CONTINUE
```

Step 5 **INSERT** your Training Disc in the right station. (The Training Disc is the Source disc.)

TOUCH the ACCPT key.

Result The Command Line displays:

```
INSERT DESTINATION DISC IN LEFT STATION --
ACCPY TO CONTINUE
```

The disc you want to duplicate the information to is already in the left disc station. Student Disc is the destination disc.

Duplicating the Disc

Step 6 **TOUCH** the ACCPT key.

Result The Command Line displays:

```
DUPLICATING DISC -- PLEASE WAIT
```

When the disc duplication is finished, the Command Line displays:

```
ENTER DISC NAME      " "
```

After you have duplicated a disc, the 860 will give you a chance to rename the destination disc (the disc that you copied to). You have two choices:

- (1) Type a new name for the disc and touch ACCPT
- (2) Touch ACCPT to give the disc the same name as the disc you duplicated from

In this exercise, you will name the disc Daily Disc.

Step 7 **TYPE** the name **Daily Disc**

TOUCH ACCPT.

Result The Command Line displays:

```
DUP SUCCESSFUL    REMOVE DISC --  
ACCPT TO CONTINUE
```

At this point, you could touch ACCPT and use the Duplicate Utility to duplicate another disc. For this exercise, you only want to duplicate one disc, so you will touch STOP and go back to the System Disc Page. Then you will load the Word Processing software and go back to the Activity Page.

Returning to the System Disc Page

Step 8 **TOUCH** the STOP key.

Result The Command Line displays:

```
CODE + 0 TO EXIT -- ACCPT TO CONTINUE
```

Step 9 **USE** CODE + 0 to return to the System Disc Page.

Result The Command Line prompts you to put the System Disc back into the Controller:

```
INSERT DISC "System Disc"
```

REMOVE both discs from the controller.

INSERT your System Disc in either station and touch ACCPT.

Result The System Disc Page is brought to the screen. The Command Line displays:

```
SELECT OPTION
```

THE INITIALIZE UTILITY

The Initialize utility is used to prepare a disc for use in the 860. The utility divides the disc into sectors and puts an INDEX on it. Without the INDEX, you cannot store documents on the disc. When you have a new disc, you must use the Initialize utility to prepare the disc before you record documents on it.

The Initialize utility also checks the disc for damage (flaws) as it divides the disc into sectors. If the disc is damaged, it will mark the damaged (flawed) sectors so they will not be used to store documents.

If you use the Initialize utility on a disc that has documents recorded on it, it will completely erase the disc and check it for flaws. Since flawed sectors can cause read or write errors in your documents, it is a good idea to use the Initialize utility to erase discs when you no longer need any of the documents on them. This way, the 860 can check for flawed sectors before you record on the disc again. Since a disc can get scratched or damaged during use, this will protect your new documents from errors.

In the exercise below, you'll initialize your Student Disc (In the last exercise you renamed it **Daily Disc**). This will erase everything on the disc and check it for flaws.

Bringing the Utility Selection Page to the Screen

- Step 1** **TOUCH** the PAGE key to bring up the Utility Page.
- CHECK** to be sure INITIALIZE is highlighted. If it is not, use the LINE key or RVRSE + LINE keys to highlight it.
- Step 2** **TOUCH** the ACCPT key.
- Result** The Command Line displays:

LOADING -- PLEASE WAIT

When the software has been loaded, the first page of the INITIALIZE Utility comes up on the screen. It explains the procedure you will use.

READ the information on the screen.

The Command Line message displays:

```
INITIALIZE LEFT DISC? -- PARA KEY TO SWITCH
STATIONS
```

This message informs you that you can use the PARA key to switch the action to the right disc station. In this case, the disc to be initialized is already in the left station so you do not need to touch PARA.

Initializing a Disc

Touching ACCPT will tell the 860 that you want to initialize the disc in the left disc station. The 860 will then check the disc to see if it is a new or used disc. The 860 will then ask you if you are sure you want to initialize this disc. This is a safe guard against error, since initializing the disc will erase all of the documents on it.

Step 3 TOUCH the ACCPT key to initialize the disc in the left station.

Result The Command Line displays:

```
DISC NAME: Daily Disc -- ARE YOU SURE? --
STOP OR ACCPT
```

Step 4 TOUCH the ACCPT key to tell the 860 that you do want to initialize your Student Disc.

Result The Command Line displays:

```
ENTER DISC NAME " "
```

Naming the Disc

A disc name can be up to 12 characters long. For this exercise, you'll give the disc the name it had before (Student Disc).

- Step 5**
- TYPE** the words **Student Disc**
- TOUCH** the ACCPT key.
- Result** The Disc Initialization procedure begins.

The 860 first initializes the disc, then verifies the disc. If you are initializing a double-sided disc, the system will initialize and verify Side 1, then initialize and verify Side 2.

When the initialization and verification are finished, a message will appear in the Command Line to show the number of flawed sectors on the disc.

When you see the message **INIT SUCCESSFUL 0 FLAWED SECTORS -- ACCPT TO CONTINUE**, you know that the initialization is complete. Everything that was stored on the disc has been erased, and the disc is ready for you to record new documents on.

The number in front of the words **FLAWED SECTORS** indicates the number of flawed sectors that the 860 found on the disc.

Now that the initialization is complete, you can return to the System Disc Page.

Returning to the System Disc Page

- Step 1**
- TOUCH** the STOP key.
- Result** The Command Line displays:

```
CODE + 0 TO EXIT -- ACCPT TO CONTINUE
```

- Step 2**
- USE** CODE + 0 to go to the System Disc Page.
- Result** The Command Line displays:

```
LOADING -- PLEASE WAIT
```

and the System Disc Page returns to the screen.

INITIALIZING A NEW DISC

If you have a new (never used) disc, follow the instructions below to initialize it. If you do not have a new disc, turn to page 8 - 22 and go on with the lesson.

As you recall, you must initialize a new disc before you can use it in the 860. Initializing the disc puts an INDEX on it so the 860 can keep track of your documents. If you put a new disc in the 860 without initializing it, the status line will show UNKNOWN for the name of the disc. You cannot record any documents on an UNKNOWN (uninitialized) disc. When you open a box of new discs, it is a good idea to initialize them all.

- | | | |
|---------------|------------------|---|
| Step 1 | CHECK | that the System Disc Page is on the screen and your System Disc is in the <u>right</u> disc station. |
| Step 2 | TOUCH | PAGE to bring up the Utility Selection Page. |
| | HIGHLIGHT | the INITIALIZE utility and touch ACCPT. |
| Step 3 | INSERT | the new disc in the <u>left</u> disc station. |
| | TOUCH | ACCPT. |
| | Result | The Command Line will display: NEW DISC? |
| | TOUCH | ACCPT to answer "yes." |
| Step 4 | TYPE | your first name (or any name up to 12 characters) as the name for the disc. |
| | TOUCH | ACCPT to begin initializing the disc. |
| | WAIT | for the INIT SUCCESSFUL message to appear. |
| | IF | you want to initialize another disc, insert the new disc in the <u>left</u> disc station and touch ACCPT. |
| Step 5 | TOUCH | STOP. |
| | USE | CODE + 0 to go to the System Disc Page. |

THE RECONSTRUCT AND RECOVER UTILITIES

The 860 has two utilities that will help recover documents when errors occur.

The **Reconstruct** Utility is used to build a new INDEX should a disc get an error in its INDEX. INDEX errors can be caused by a flawed sector, dirt on the disc or any other condition that makes it hard for the 860 to read the INDEX. When you get an INDEX error, you will not be able to recall the documents on the disc.

If you get an INDEX error, you will get the message SYSTEM ERROR followed by numbers and **NDX**. When you get an NDX type system error, use the Reconstruct utility. (The different types of SYSTEM ERRORS are listed in the messages section of your Reference Manual.)

The **Recover** utility is used to recover a document that was never stored. For instance, a document that you were working on when the electricity went off or when you got a SYSTEM ERROR that would not allow you to store it. The Recover utility will usually recover all of a new document and put it in the INDEX. However, it may not get back revisions when you are editing a document that has already been stored.

The "**How To**" **Glossary** of your Reference Manual has detailed information about each of the utilities. Refer to it when you need to use one of these utilities.

You have now completed your training on the utilities. Your Reference Manual contains more information on the Utilities, including the Convert, Reconstruct, Recover and Rename utilities. You can refer to it whenever you need to use any of the utilities.

On the next pages there are Points to Remember and an Action Summary for you to review. There is also a Progress Check for you to complete. If you should answer any of the questions incorrectly, turn to the page indicated in the answer and review the information.

Lesson Eight--UTILITIES

POINTS TO REMEMBER

- To use a utility, you must begin on the System Disc Page. If the Activity Page is on the screen, use CODE + 0 to go to the System Disc Page. Then touch PAGE to bring up the Utility Selection Page. (Page 8-3)
- When you're finished with a utility, you touch STOP and CODE + 0 to get back to the System Disc Page. (Page 8-9)
- The Initialize Utility is used to prepare a new disc for use in the 860. The Initialize Utility checks the disc for flawed sectors so the 860 won't use them when you record information. (Page 8-18)
- It is also a good idea to use the Initialize Utility to erase and reinitialize a disc when you no longer need the documents on it. (Page 8-18)
- The Duplicate Utility is used when you want to make an exact copy of a disc. When you use Duplicate, all the information on the disc you copy to (the destination disc) will be erased. (Page 8-14)
- The Reconstruct Utility is used to "rebuild" an INDEX when there is an error in the INDEX. (Page 8-22)
- The Recover Utility is used to recover an unstored document if your system loses power. (Page 8-22)
- The Rename Utility is used when you want to give a disc a new name. The name can be up to 12 characters. (Page 8-4)
- The Backup Index Utility is used when you want to recover deleted documents or an entire disc. It is also used to permanently delete documents and free up disc space. (Pages 8-6 and 8-11)
- The Convert Utility is used when you want to convert 850 discs to 860 discs, or vice versa. (Page 8-4)

ACTION SUMMARY

You may want to make a copy of this ACTION SUMMARY and keep it on your desk for quick reference.

The Utilities are used to do special tasks that you perform less frequently. The Utilities stay on the System Disc and are accessed from the System Disc Page.

To bring up the Utility Selection Page:

- Step 1 RECALL** the System Disc Page, using one of the following steps:
- If you are on the Activity Page, touch CODE + 0
 - If you haven't loaded the software yet, insert the System Disc, type the date, and touch LINE
- Step 2 TOUCH** the PAGE key to bring the Utility Selection Page to the screen.

The Backup Index Utility is used to permanently delete documents from the disc, and to recover documents that were accidentally deleted from the INDEX.

To use the Backup Index:

- Step 1 HIGHLIGHT** BACKUP INDEX on the Utility Selection Page.
- TOUCH** ACCPT.
- Step 2 SELECT** the disc station with the desired disc, using the following steps:
- Insert the disc with the Index
 - Check the highlighting in the status line
 - Touch PARA to highlight the correct disc station
- Step 3 RECOVER** documents from the Backup Index using one of the following methods:
- To recover individual documents:
 - Touch LINE to highlight the document title (use MARK and LINE to select and mark several titles)
 - Touch ACCPT twice
 - To recover all documents:
 - Touch ACCPT twice
- Step 4 DELETE** documents from the Backup Index using one of the following methods:
- To delete individual documents:
 - Touch LINE to highlight the document title (use MARK and LINE to select and mark several titles)
 - Touch DEL
 - Touch ACCPT
 - To delete all documents:
 - Touch DEL
 - Touch ACCPT
- Step 5 TOUCH** STOP and CODE + 0 to return to the System Disc Page.

ACTION SUMMARY -- CONTINUED

The Initialize Utility is used to prepare a disc for use in the 860. It can also be used to erase a previously used disc and check it for damage (flawed sectors).

To use the Initialize Utility:

- | | | |
|---------------|------------------|---|
| Step 1 | HIGHLIGHT | INITIALIZE on the Utility Selection Page. |
| | TOUCH | ACCPT. |
| Step 2 | SELECT | the disc station with the desired disc, using the following steps: <ul style="list-style-type: none">● Insert the disc to be initialized● Touch PARA to move to the correct disc station |
| Step 3 | TOUCH | ACCPT. |
| | TYPE | a name for the disc (if the disc already has a name, touch ACCPT and type a new name). |
| | TOUCH | ACCPT again. |
| | WAIT | for the disc to be initialized. |
| Step 4 | TOUCH | STOP when initialization is complete. |
| | TOUCH | CODE + 0 to return to the System Disc Page. |

ACTION SUMMARY — CONTINUED

The Duplicate Utility makes an exact copy of the INDEX of one disc on to another disc. It will erase any documents on the disc that receives the copy, so you want to be sure to use a blank disc.

To use the Duplicate Utility:

- Step 1** **HIGHLIGHT** DUPLICATE on the Utility Selection Page.
 TOUCH ACCPT.
- REMOVE** the System Disc when the software is loaded.
 TOUCH ACCPT.
 TOUCH ACCPT again.
- Step 2** **INSERT** the source and destination discs, using the following steps:
- Insert the disc to be duplicated from (source) in the left disc station
 - Touch ACCPT
 - Insert the disc to receive the duplicated information (destination) in the right disc station
- Step 3** **TOUCH** ACCPT.
 WAIT for the disc to be duplicated.
- Step 4** **TYPE** a name for the disc.
 TOUCH ACCPT.
- Step 5** **TOUCH** STOP.
 REMOVE both discs and touch ACCPT.
 INSERT the System Disc and touch ACCPT.
 TOUCH CODE + 0 to return to the System Disc Page.

Lesson Eight--UTILITIES

(This page is intentionally left blank.)

PROGRESS CHECK

Answer each question by filling in the blank with the correct answer, then compare your answers with those on Page 8-31.

Write the utility name on the line in front of each description. Below are the names of seven of the 860's system utilities:

BACKUP INDEX
 CONVERT
 DUPLICATE
 INITIALIZE
 RECONSTRUCT
 RENAME
 RECOVER

1. _____ This utility allows you to give a disc a new name.
2. _____ This utility allows you to recover deleted documents and to permanently delete documents.
3. _____ This utility makes an exact copy of a disc.
4. _____ This utility converts information from an 850 disc to an 860 disc, or vice versa.
5. _____ This utility rebuilds an Index on your disc when there have been disc errors in the Index.
6. _____ This utility prepares new discs for use in the 860. It also checks the disc for damaged or "flawed" sectors.

Write true or false in front of each statement below.

7. _____ You use STOP and then CODE + 0 to return to the System Disc Page after finishing with any one of the utilities.
8. _____ To move to the Utility Page from the System Disc page, you touch the PARA key.
9. _____ When you delete documents from the BACKUP INDEX, they are permanently gone and can no longer be recovered.
10. _____ When you access each of the system utilities, the 860 displays brief instructions on how to use the utility.

(This page is intentionally left blank.)

ANSWERS TO PROGRESS CHECK

If you are uncertain or answered a question incorrectly, refer to the pages listed on this answer form to review the original material. When you feel comfortable with the material, return to this point in the lesson and continue.

Write the utility name on the line in front of each description. Below are the names of seven of the 860's system utilities:

BACKUP INDEX
 CONVERT
 DUPLICATE
 INITIALIZE
 RECONSTRUCT
 RENAME
 RECOVER

1. RENAME This utility allows you to give a disc a new name. (Page 8-4)
2. BACKUP INDEX This utility allows you to recover deleted documents and to permanently delete documents. (Page 8-6)
3. DUPLICATE This utility makes an exact copy of a disc. (Page 8-14)
4. CONVERT This utility converts information from an 850 disc to an 860 disc, or vice versa. (Page 8-4)
5. RECONSTRUCT This utility rebuilds an Index on your disc when there have been disc errors in the Index. (Page 8-22)
6. INITIALIZE This utility prepares new discs for use in the 860. It also checks the disc for damaged or "flawed" sectors. (Page 8-18)

Write true or false in front of each statement below.

7. True You use STOP and then CODE + 0 to return to the System Disc Page after finishing with any one of the utilities. (Page 8-9)
8. False To move to the Utility Page from the System Disc page, you touch the PARA key. (Page 8-3)
9. True When you delete documents from the BACKUP INDEX, they are permanently gone and can no longer be recovered. (Page 8-11)
10. True When you access each of the system utilities, the 860 displays brief instructions on how to use the utility. (Page 8-7)

Lesson Eight--UTILITIES

(This page is intentionally left blank.)

Xerox 860 IPS Operator Manual
Book One: Fundamentals

Lesson Nine – System Disc
Creating a System Disc

LESSON NINE

SYSTEM DISC

Working with System Discs

OBJECTIVES

After finishing this lesson you will:

- know more about the System Disc
- know when to create a System Disc
- know how to change the Master Format on the System Disc

Materials Needed

For this lesson you will need:

- System Disc

THE SYSTEM DISC

In Lesson One you learned that the System Disc contains software (or operating instructions) that have to be put into the 860's memory every time you turn the 860 on.

You also learned that the 860 needs to get more software off the System Disc when you do certain operations, like printing a document. If the System Disc is not in the controller when the 860 needs more software, it will ask for it by displaying the message "INSERT DISC System Disc Name". When you see this message, you should insert the System Disc and touch ACCPT.

The Master Disc

A disc called the Master Disc is used to create a System Disc. Your 860 was delivered with a Word Processing Master Disc, and you or the Xerox Service Representative made a System Disc so you could use the 860.

The Master Disc contains software which is copied onto the System Disc. The Master Disc cannot be used to put software in the 860's memory. When you create a System Disc, you tell the 860 which software to copy from the Master Disc to the System Disc. For instance, when you have a Standard Printer and an Automatic Paper Feeder, you tell it to put that software on the System Disc; or, if you have the Wide Bed Printer, you tell it to put that software on the System Disc; and so forth.

Creating a System Disc

You already know that you have to create a System Disc before you can use a brand new 860. There will be other times when you will need to create System Discs:

- When you receive a new Master Disc. From time to time, Xerox sends out new Master Discs which contain new features or improvements to existing features. You should always make a new System Disc when you get a new Master Disc.
- When you get a Master Disc for a feature other than Word Processing. Since the 860 can do tasks in addition to Word Processing, your office may purchase other Master Discs. Examples of the applications on purchased Master Discs are Communications, Records Processing, and Program Create.
- When you change your 860's hardware configuration. Should you get a different printer, an Automatic Paper Feeder, or a different type of disc drive, you'll need to change the hardware configuration on your System Disc.

You can use the Word Processing Master Disc to create a System Disc for any 860. However, a System Disc can only be used in the 860 it was created on. Each 860 writes a code on the System Disc that personalizes it for use in that system. This prevents its use in other 860 systems.

If you make a System Disc from an applications Master Disc (such as Communications), that Master Disc will also be personalized to the 860 it is used in. Therefore, you cannot use the Master Disc to make a System Disc for another 860. If you have several 860's in your office, be sure you use the Master Disc in the 860 that will be used for that application.

Whenever you make a System Disc, it is a good idea to label it as a **System Disc**. Along with the name of the software, you should include the level. (The software level is shown on the back of the Master Disc under the word Description -- for example WP-E6.000.) If you call the Customer Support Center for assistance, they will want to know the level of the software you are using.

The Reference Manual contains complete instructions for making System Discs. When you get a new Master Disc, look up the instructions for making a System Disc in the **"How To" Glossary** of the Reference Manual.

The Master Format

From the training, you know that the format is automatically set at the standard values whenever you begin a new document. For example, margins of 12 and 84, no tabs, single line spacing, etc.

If these settings are not convenient for you, you can change the Master Format on the System Disc. When you change the format settings on the Master Format, it will automatically change the standard values on the Recordable and Non-Recordable Format Pages.

In the next exercise, you'll bring up the Master Format Page from your System Disc. Illustration IX-2 on the opposite page shows the Master Format.

Changing the Master Format

- Step 1**
- CHECK** to be sure the System Disc is in the 860.
- BRING** up the System Disc Page using the following steps:
- If the Activity Page is on the screen, touch CODE + 0.
 - If your 860 is turned off, turn it on, enter today's date and touch line.
- TOUCH** the FORMAT key.
- Result** The Master Format Page is displayed.
- Step 2**
- LOOK** at the Master Format Page on your screen.
- If you wanted to change the format settings, you would use the following steps:
- Use the PARA and LINE keys to advance through the lines
 - Use the CHAR key to turn options on or off
 - Type the desired number, where one is required
- Step 3**
- TOUCH** the ACCPT key when you have finished.
- Result** The Master Format Page is removed from the screen. If you made changes in the format settings, the new settings are recorded on the System Disc.

WORD PROCESSING MASTER FORMAT	
MARGINS	12 84
TABS / SPEC TABS	1 1½ 2 3
LINE SPACING	<input type="checkbox"/>
JUSTIFY	<input type="checkbox"/>
PITCH	PS 10 12
KB/PW	STD LEGAL
PRINT WHEEL ID	
PAGE LAYOUT	
TOP MARGIN	6
BOTTOM MARGIN	6
PAPER SIZE	66
PRINT OPTIONS	
CONTINUOUS FORM	<input type="checkbox"/>
PAPER SIZE	0
EDIT OPTIONS	
EDIT REFORMAT	<input type="checkbox"/>
UNATTENDED	<input type="checkbox"/>
AUTO CARRIER RETURN	<input type="checkbox"/>
AUTO PAGING	<input type="checkbox"/>
MARGIN ZONE	5
SPACE SIZE	3 7
OVERSTRIKE SYMBOL	/
DISPLAY OPTIONS	
ZOOM LINE	<input type="checkbox"/>
ZOOM SCREEN	<input type="checkbox"/>
SPLIT LINE	<input type="checkbox"/>
DARK SCREEN	<input type="checkbox"/>
CODE DISPLAY	<input type="checkbox"/>
HORIZONTAL SCROLL	40

Master Format Page
Illustration IX-2

After you change the format settings and load the System Disc, your 860 will use the new Master Format settings. Brief descriptions of the PRINT, EDIT and DISPLAY OPTIONS are given below and on the next page. You can refer back to these if you want to change the options at some time in the future.

PRINT OPTIONS

- **CONTINUOUS FORM** - When this option is turned on, the 860 will advance continuous form paper through the printer automatically without stopping at page ends.
- **PAPER SIZE** - This option changes the paper size for the continuous form paper. When it is set at 0, the 860 will use the paper size recorded in the format block of the document it is printing. If the paper size used in the printer is different, you can change this option to the new paper size.

EDIT OPTIONS

- **EDIT REFORMAT** - When this option is turned on, the 860 rearranges line endings while you edit a document. If the UNATTENDED option is not selected, the system will ask for hyphenation decisions as you edit.
- **UNATTENDED** - This option works with EDIT REFORMAT. When UNATTENDED is selected, words are rearranged as you edit the document, but no hyphenation decisions are displayed. UNATTENDED cannot be used if EDIT REFORMAT is turned off.
- **AUTO CARRIER RETURN** - When this option is turned on, the 860 automatically carrier returns when the margin zone is approached.
- **AUTO PAGING** - When this option is turned on, a temporary page end code is automatically inserted after the last text line of each page.
- **MARGIN ZONE** - The margin zone is the area near the right margin where conversions are made on text that is not justified. The minimum value is 0, and the maximum value is the left margin setting subtracted from the right margin setting.
- **SPACE SIZE** - This option determines the minimum and maximum allowable space size, in units, to use in justifying text. The space size determines how much room can be left between each word on a line. The minimum can be 2, 3, or 4 and the maximum can be any number from 5 to 99.
- **OVERSTRIKE SYMBOL** - This option determines which character will be used to overstrike text. The standard character is a hyphen (-). You can change the symbol to any character you want.

DISPLAY OPTIONS

- **ZOOM LINE** - When this option is turned on, the line on which you are typing will appear double the normal height.
- **ZOOM SCREEN** - When this option is turned on, all displayed text will appear double the normal height.
- **SPLIT LINE** - When this option is turned on, all lines that exceed the current screen width will be displayed on the screen by breaking the line and displaying the remainder on successive lines.
- **DARK SCREEN** - When this option is turned on, the screen will show white characters on a black background.
- **CODE DISPLAY** - When this option is turned on, all codes and functions are displayed.
- **HORIZONTAL SCROLL** - This option determines the number of characters that will be scrolled horizontally on the screen when a line of text exceeds 102 characters. The minimum is 10 characters, and the maximum is 80 characters. Any number between 10 and 80 may be entered. The standard is 40 characters.

Lesson 9--SYSTEM DISC

You have now completed Lesson Nine. On the next page there are Points to Remember for you to review.

POINTS TO REMEMBER

System Disc

- A System Disc is used to put software into the 860 so it will know how to respond to your keystrokes. The System Disc is used each time the 860 is turned on. (Page 9-2)
- A System Disc is made from a Master Disc. (Page 9-2)
- A System Disc can only be used in the 860 system that it was created on. The 860 writes a code on the System Disc that personalizes it and prevents you from using it in another 860. (Page 9-3)
- There are several times when you'll need to create a System Disc: (Page 9-2)
 - When you get a new 860 (if the Xerox Service Representative didn't make the first System Disc for you).
 - When you receive a new Master Disc.
 - When you receive a Master Disc for a new application (like Communications or Records Processing).
 - When you change the hardware configuration of your 860.
- Complete instructions for making System Discs are given in the **"How To" Glossary** of the Reference Manual. (Page 9-3)
- You can change any of the format settings on your System Disc by touching the FORMAT key when the System Disc Page is displayed. When you change these settings, they will become the standard format settings. (Page 9-4)

(This page is intentionally left blank.)

860 INFORMATION PROCESSING SYSTEM

REFERENCE MANUAL

HISTORY PAGE

This package contains supplement pages to be inserted in your 860 IPS Reference Manual. To update your manual, insert this page as the first page in the manual, then remove and add new pages as instructed below.

MANUAL REORDER # 9R80149

		<u>Part #</u>	<u>Master Disc</u>
Manual Issue Date:	4/01/80	610P70533	WP-A3.000
Supplement Dates:	4/28/80	610P70538	WP-A4.000
	7/21/80	610P70538	WP-B4.400
	9/01/80	156P20800	WP-C5.000 GP-C2.000
	1/05/81	156P20801	WP-E6.000 GP-E4.000
	3/11/81	156P20802	WP-E6.000 GP-E4.000
	9/15/81	156P20803	WP-H6.200 GP-H6.200
	2/15/82	156P82604	WP-H6.200 GP-H6.200

<u>SECTION</u>	<u>REMOVE</u>	<u>ADD</u>
Discs & Peripherals	6-7, 6-8	6-7 through 6-18

This supplement updates the SPI documentation to the 6.2 software level.

