

8420 and 8422 Diskette Subsystems

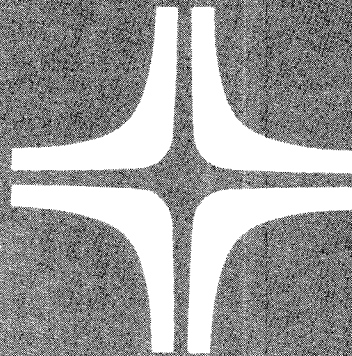

General Description

This document contains the latest information available at the time of preparation. Therefore, it may contain descriptions of functions not implemented at manual distribution time. To ensure that you have the latest information regarding levels of implementation and functional availability, please consult the appropriate release documentation or contact your local Sperry Univac representative.

Sperry Univac reserves the right to modify or revise the content of this document. No contractual obligation by Sperry Univac regarding level, scope, or timing of functional implementation is either expressed or implied in this document. It is further understood that in consideration of the receipt or purchase of this document, the recipient or purchaser agrees not to reproduce or copy it by any means whatsoever, nor to permit such action by others, for any purpose without prior written permission from Sperry Univac.

Sperry Univac is a division of the Sperry Corporation.

FASTRAND, SPERRY UNIVAC, UNISCOPE, UNISERVO, and UNIVAC are registered trademarks of the Sperry Corporation. ESCORT, PAGEWRITER, PIXIE, and UNIS are additional trademarks of the Sperry Corporation.

This document was prepared by Systems Publications using the SPERRY UNIVAC UTS 400 Text Editor. It was printed and distributed by the Customer Information Distribution Center (CIDC), 555 Henderson Rd., King of Prussia, Pa., 19406.

Contents

1. INTRODUCTION	1
2. SUBSYSTEM DESCRIPTION	3
2.1. GENERAL	3
2.2. CONFIGURATION AND OPTIONAL FEATURES	3
2.3. CHARACTERISTICS	6
2.4. SUBSYSTEM COMPONENTS	8
2.4.1. Interface	8
2.4.2. Microprocessor	8
2.4.3. Diskette Drive	8
2.4.4. Autoloader	9
2.5. DISKETTE MEDIA	9
2.6. RECORDING FORMAT	10
2.7. DATA TRANSFER RATE	13
3. SOFTWARE CONTROL	14
3.1. GENERAL	14
3.2. COMMAND REPERTOIRE	14
3.3. STATUS BYTE	15
3.4. SENSE BYTES	15

4.	OPERATOR CONTROLS AND INDICATORS	17
4.1.	OPERATOR CONTROLS	17
4.1.1.	Manual Load/Unload Requirements	17
4.1.2.	Autoload/Unload Requirements	17
4.2.	INDICATORS	18
4.2.1.	LED Indicator	18
4.2.2.	Interlock/Reset Switch	18
4.2.3.	FEED Switch/Indicator	19
4.2.4.	Drive Read/Write Indicator	19
4.2.5.	Other Indicators	19

5.	PHYSICAL CHARACTERISTICS	20
5.1.	DIMENSIONS	20
5.2.	ENVIRONMENTAL REQUIREMENTS	21
5.3.	WEIGHT	22
5.4.	HEAT DISSIPATION	22
5.5.	POWER REQUIREMENTS	23
5.6.	NOISE SUPPRESSION	23
5.7.	DISKETTE HANDLING	23

FIGURES

1-1.	SPERRY UNIVAC 8420 and 8422 Diskette Subsystems	1
2-1.	8420 and 8422 Diskette Drive Configurations	4
2-2.	8420 and 8422 Diskette Subsystems/System Interface	8
2-3.	Diskette Characteristics	9
2-4.	FM Track Format	11
2-5.	MFM Track Format	12
4-1.	Manual-Load Diskette Drive Indicator	18
4-2.	Autoload Diskette Drive FEED Switch and Indicator	19
5-1.	Manual-Load Diskette Drive Cabinet	20
5-2.	Autoload Diskette Drive Cabinet	21

TABLES

2-1.	Diskette Drive Types and Optional Features	5
2-2.	8420 and 8422 Diskette Subsystems Characteristics	6
2-3.	Diskette Media Numbers	10
2-4.	Data Transfer Rates for Diskettes	13
3-1.	Commands	14
3-2.	Status and Sense Bytes	16
5-1.	Diskette Drive Weights	22
5-2.	Diskette Drive Heat Dissipation	22
5-3.	Diskette Drive Power Requirements	23



1. Introduction

The SPERRY UNIVAC 8420 and 8422 Diskette Subsystems (Figure 1-1) are storage devices integrated with the system processor. Each subsystem has a self-contained drive mechanism and a microprogrammed controller resident in the system processor cabinet. The diskette drives may be manually loaded (type 8422) or automatically loaded (type 8420).

The diskette drive cabinet, with or without the diskette extension cabinet, forms a physical part of the overall system cabinet complex.

Either diskette subsystem uses removable and interchangeable diskette storage media with their microprogrammed controller interfacing the processor.

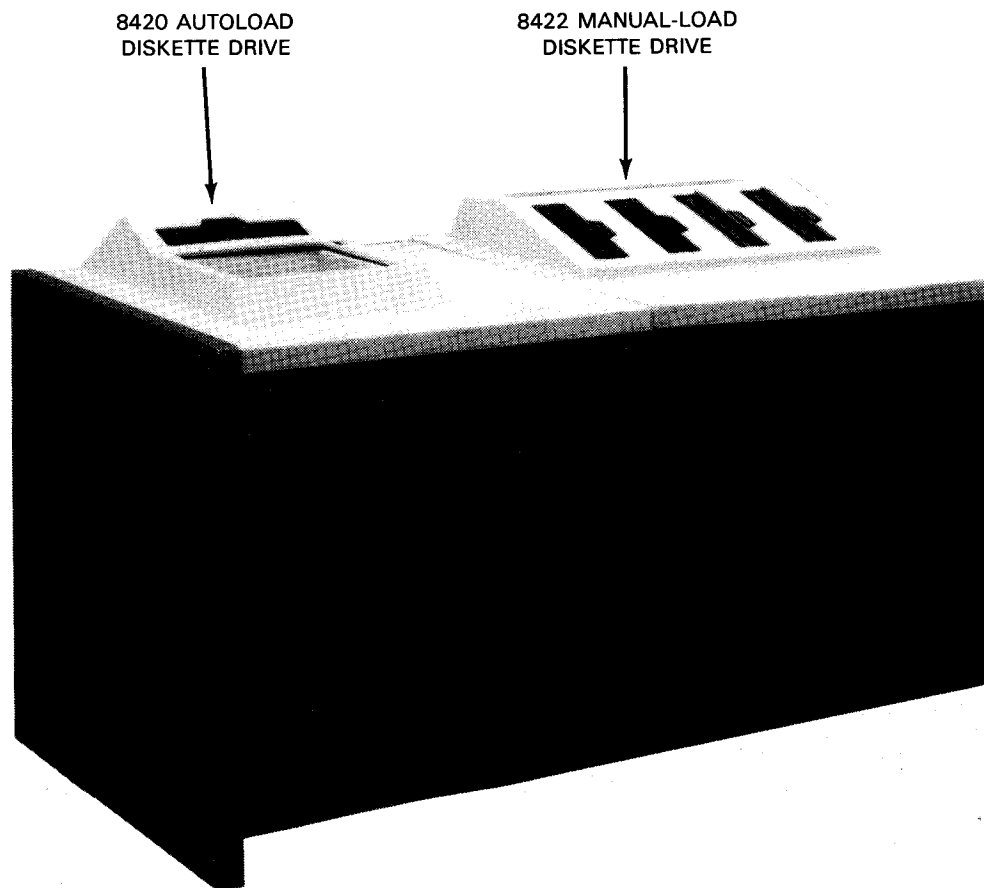

Figure 1-1. SPERRY UNIVAC 8420 and 8422 Diskette Subsystems

Each subsystem is a buffered input/output peripheral device providing floppy type diskettes capable of loading and unloading programs and data to a host system. It reads and writes 1- or 2-sided diskettes that are recorded in either single density (FM) or double density (MFM) method.

An expansion autoloader cabinet is also available. This permits manually loaded or autoloader drives to be in the integrated cabinet and an autoloader drive in the expansion cabinet.

This expansion autoloader drive can optionally include a manually loaded diskette drive. However, all drives, whether integrated or in the expansion cabinet, are under control of the controller and are limited to four drives.

Detailed programmer information for these diskettes is found in the I/O integrated controller programmer reference, UP-8742 (current version). Specifications for the diskette media are found in the media and expendable supply manuals, UP-8593 (current version) for single-sided diskette media and UP-9166 (current version) for double-sided diskette media.

2. Subsystem Description

2.1. GENERAL

The diskette drive is a direct access storage device. The drive characteristics are:

- Each drive accepts only one diskette at a time.
- Each diskette is removable and interchangeable with all drives.
- Each drive has an input/output capability for loading and unloading programs and data to the processor.

Both the autoloader and manual-load drives are controlled by the microprogrammed controller located in the system processor cabinet. The controller can handle up to four drives and two autoloader mechanisms.

The autoloader drive mechanism provides an automatic means of loading and unloading the diskettes. It can sequentially process up to 20 diskettes.

2.2. CONFIGURATION AND OPTIONAL FEATURES

Drive configurations for the cabinets are:

- Integrated manual load or integrated autoloader
- Extension autoloader and manual load

These configurations are shown in Figure 2-1. Optional features are listed and briefly described in Table 2-1.

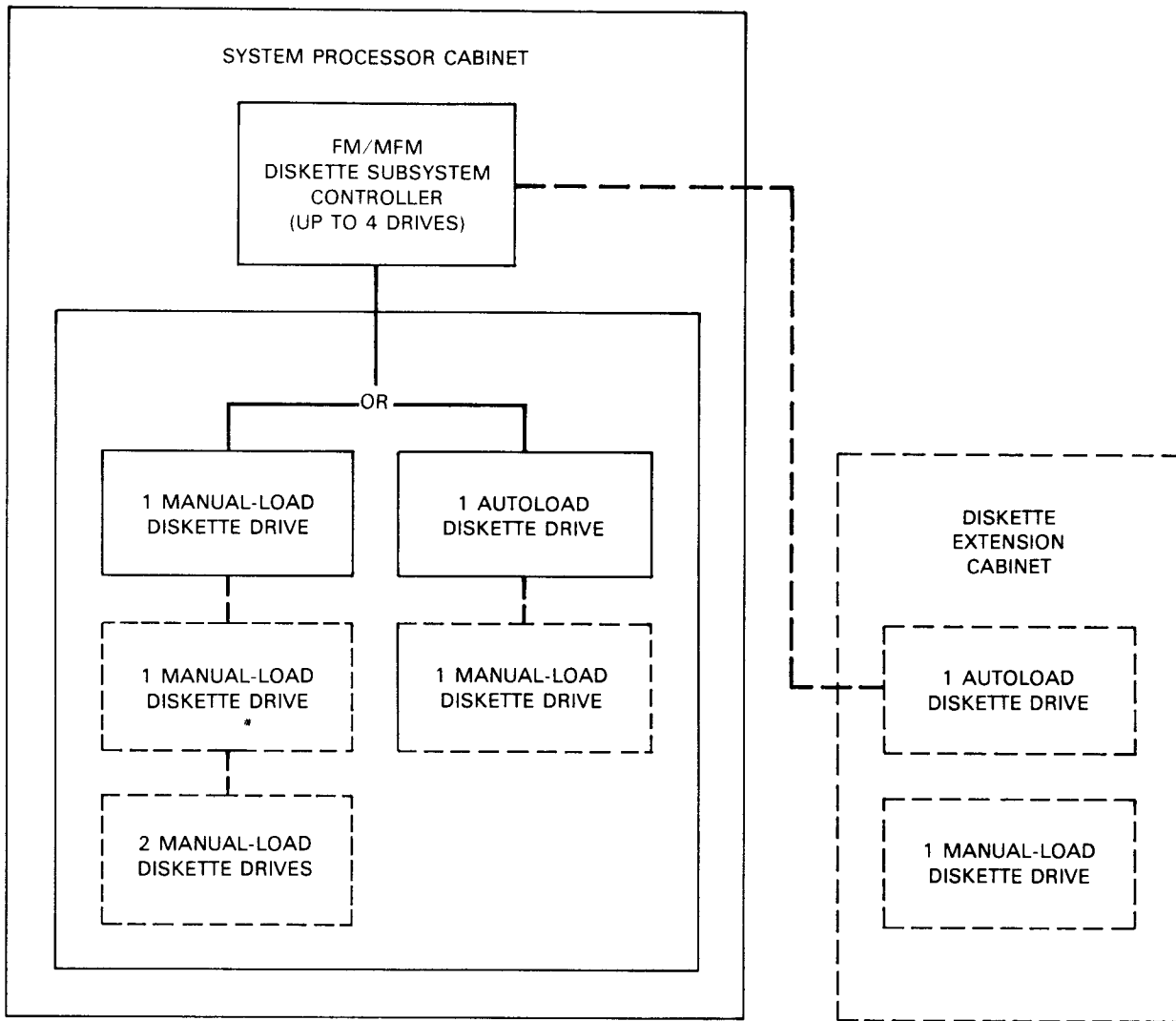

LEGEND:

Optional features

Figure 2—1. 8420 and 8422 Diskette Drive Configurations

Table 2—1. Diskette Drive Types and Optional Features

Item	Description
Type 8422-00 Diskette Drive, 60 Hz	Manual-load diskette drive with cabinet capable of housing four manual diskette drives. Reading and writing on the diskette can be either single-density FM* or double-density MFM**. The diskette drive can process either single-sided or double-sided diskette media. Interface with the host processor is via the diskette controller located in the processor cabinet or processor expansion cabinet. Operates with 220 volts, 60 Hz power.
Type 8422-01 Diskette Drive, 50 Hz	Same as type 8422-00 diskette drive except operates with 50 Hz power.
Type 8420-00 Diskette Drive, 60 Hz	Autoload diskette drive with cabinet capable of housing one autoload diskette drive and one manual-load diskette drive. Autoload hopper and stacker each holds 20 diskettes. Diskette drives read and write at single-density FM or double-density MFM. The diskette drive can process either single-sided or double-sided diskette media. Interface with the host processor is via the diskette controller located in the processor cabinet or processor extension cabinet. Operates with 220 volts, 60 Hz power.
Type 8420-01 Diskette Drive, 50 Hz	Same as type 8420-00 diskette drive except operates with 50 Hz power.
Manual Diskette Drive used with Autoload Diskette Drive, 60 Hz	Single manual-load diskette that operates in the same manner as those in the 8422 diskette drive cabinet, except that it is located in the type 8420 cabinet. Operates with 60 Hz power.
Manual Diskette Drive used with Autoload Diskette Drive, 50 Hz	Same as manual diskette for autoload diskette drive (60 Hz), except operates with 50 Hz power.
Manual Diskette Drive Expansion, 60 Hz	Allows an additional manual diskette drive to be located in the 8422 cabinet. Up to four drives may be located in one cabinet. Operates with 60 Hz power.
Manual Diskette Drive Expansion, 50 Hz	Same as manual diskette expansion (60 Hz), except operates with 50 Hz power.
Two Manual Diskette Drives Expansion, 60 Hz	Allows two additional manual diskette drives to be located in the 8422 cabinet. Up to four drives may be located in one cabinet. Operates with 60 Hz.
Two Manual Diskette Drives Expansion, 50 Hz	Same as two manual diskette expansion (60 Hz), except operates with 50 Hz.
Diskette Controller for MFM and FM	Diskette controller capable of operating with diskettes using FM recording and MFM recording.

* Frequency modulation

** Modified frequency modulation

2.3. CHARACTERISTICS

Table 2-2 lists the functional characteristics of the 8420 and 8422 diskette subsystems.

Table 2-2. 8420 and 8422 Diskette Subsystems Characteristics (Part 1 of 2)

Item	Description
Drive mechanisms	4 maximum (See Figure 2-1.)
Data read/write heads per drive	2
Access time:	
▪ Track-to-track seek	3 ms
▪ Seek settling	15 ms
▪ Head loading	35 ms
Physical tracks per diskette	77 tracks per side
Rotational speed	360 rpm
Tracks per inch	48
Number of sectors per track	Dependent on density method and sector length
Bytes per sector	Dependent on density method and user choice
Data transfer rates	<ul style="list-style-type: none"> ▪ 31.25 kilobytes/second for FM ▪ 62.5 kilobytes/second for MFM (maximum) (Dependent on sector sequence arrangement)
Density	3400 or 6800 bpi (1338 or 2287 bpcm)
Storage capacity per diskette	Recording is on one or both sides of the diskette, depending on the version used. <ul style="list-style-type: none"> ▪ Double density, 2 sides approximately 1000 kilobytes (1 megabyte) ▪ Double density, 1 side approximately 500 kilobytes ▪ Single density, 2 sides approximately 500 kilobytes ▪ Single density, 1 side approximately 250 kilobytes
Data format	The standard data character is an 8-bit byte and can be any code. EBCDIC should be used for IBM basic data exchange compatibility (single density) and for IBM Type H compatibility (double density).

Table 2—2. 8420 and 8422 Diskette Subsystems Characteristics (Part 2 of 2)

Item	Description
<p>Data processing compatibility:</p> <ul style="list-style-type: none"> ▪ MFM <ul style="list-style-type: none"> 256 bytes per sector, 26 sectors per track 512 bytes per sector, 15 sectors per track ▪ FM <ul style="list-style-type: none"> 128 bytes per sector, 26 sectors per track 256 bytes per sector, 15 sectors per track 512 bytes per sector, 8 sectors per track 	
<p>Data Access Mode (DAM)</p>	<p>DAM provides the user with unrestricted access and operation with the mounted diskette.</p>
<p>Data Set Mode (DSM)</p>	<p>DSM allows the user to process data, arranged in a file structure, according to Sperry Univac Standards. (Formats are illustrated in Figures, 2-4, 2-5, and 2-6.) Less user support is needed in processing sequential files.</p>
<p>Data set label checking</p>	<p>The diskette checks certain fields of a data set label and declares invalid labels when certain conditions exist.</p>
<p>Autoloaders</p>	<p>Maximum of 2 per subsystem</p>
<p>Autoloader hopper</p>	<p>Holds 20 diskettes maximum</p>
<p>Autoloader stacker</p>	<p>Holds 20 diskettes maximum</p> <p>The load or unload time per diskette is</p> <ul style="list-style-type: none"> ▪ 5 seconds maximum, 60 Hz ▪ 6 seconds maximum, 50 Hz

2.4. SUBSYSTEM COMPONENTS

2.4.1. Interface

Figure 2-2 illustrates the interface of the diskette microprogrammed controller in the processor cabinet. The data path is 9 bits wide (8 data and 1 parity bit). All information is transferred via this path from the diskette controller to the processor.

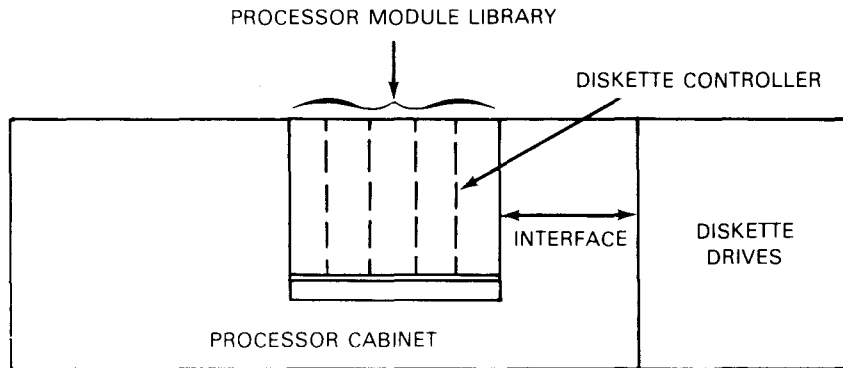

Figure 2-2. 8420 and 8422 Diskette Subsystems/System Interface

2.4.2. Microprocessor

All operations performed by either diskette subsystem are under control of a microprocessor. This microprocessor employs five 2-bit-slice central processing element (CPE) integrated circuits with a 4K by 32-bit control store (PROM) and a 1K by 9-bit read/write (RAM) memory. Control store sequencing is accomplished by programmable logic arrays (PLAs).

The microprocessor uses 256 bytes of the RAM for a working area; the remaining 768 bytes are used as record buffers. This provides six 128-byte record buffers when the record length format is 128 bytes per sector, three 256-byte record buffers when the record length format is 256 bytes per sector, and one 512-byte record buffer when the record length format is 512 bytes per sector.

2.4.3. Diskette Drive

The flexible diskette drive mechanism is a direct access storage device. It uses the standard 8-inch removeable and interchangeable diskette storage media and accepts only one diskette at a time. It has two heads that come into contact simultaneously with the diskette. This allows reading and writing on both sides of the diskette.

2.4.4. Autoloader

The autoloader mechanism hopper has a maximum capacity of 20 diskettes and an empty-hopper detection sensor. The stacker also has a capacity of 20 diskettes; the diskettes are stacked in the same sequence in which they are fed. A stacker-full detection is also provided.

Diskettes are fed one at a time upon command, starting with the one nearest the mechanism, using a mechanical picker technique. An autoloader mechanism cycle consists of unloading a diskette from the drive to the stacker and then loading a diskette from the hopper to the drive. This autoloader mechanism cycle has a duration of 5.9 (± 0.5) seconds maximum at 50 Hz and 5.3 (± 0.4) seconds at 60 Hz.

2.5. DISKETTE MEDIA

The diskette media for the subsystems are removable and interchangeable magnetic storage media consisting of a single flexible disk enclosed in a jacket. One version of the media allows recording only on one side of the diskette; a second version allows recording on both sides.

The diskette has 77 recording tracks per side with each track being divided into 26, 15, or 8 sectors. The tracks are numbered from 00 to 76 with track 00 being designated as the outermost track. Typically, track zero is reserved for labels, and tracks 1-74 are used to store data. Tracks 75 and 76 are used as alternate data tracks when there are defective tracks in the data area (tracks 1-74).

Figure 2-3 illustrates the diskette media characteristics; Table 2-3 lists the various media that can be used on the subsystem.

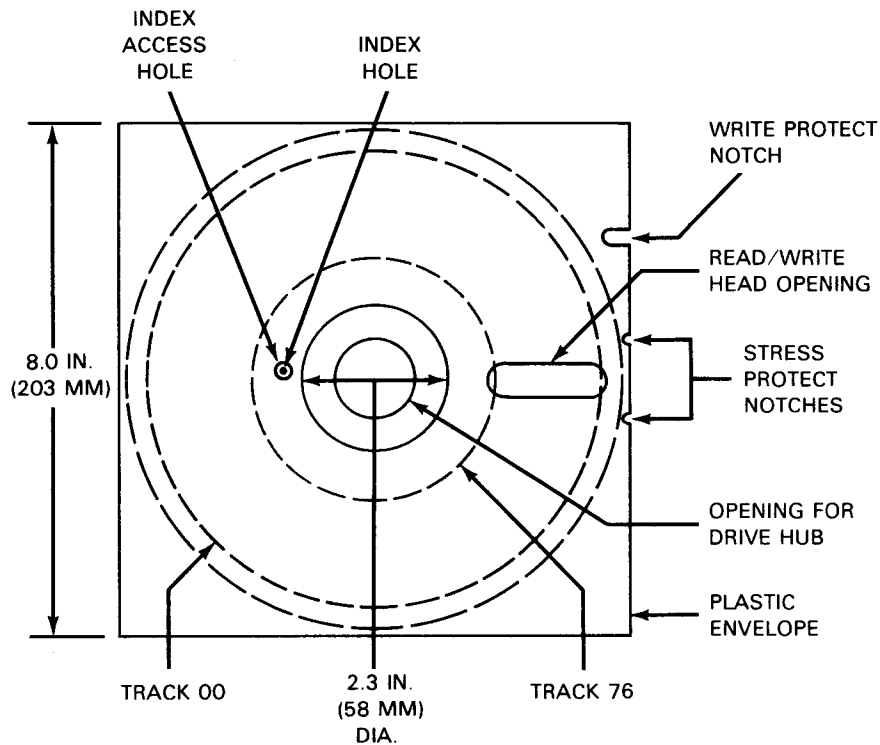

Figure 2-3. Diskette Characteristics

Table 2-3. Diskette Media Numbers

	Purchase Part Number	Description
Single sided	9040092	Unrecorded
	9040185	Unrecorded, write protected
	9040095	CE Alignment
Double sided	9042225	Unrecorded
	9042226	Unrecorded, write protected
	9040095	CE Alignment

For write protection, the write protect notch (Figure 2-3) can be covered with a pressure sensitive tab, since protection is controlled by the hardware recognizing a covered (write) or uncovered (write inhibit) notch.

A special head cleaning kit is available that contains special diskette and cleaners that are used to clean the heads of the disk drives. These special cleaning kits are identified by Sperry Univac part number 2893177-00, or Innovative Computer Products part number FD-08.

2.6. RECORDING FORMAT

The diskette subsystems employ a fixed-format approach using electronic sectoring. Information recorded on the tracks consists of gap bytes, sync bytes, track/sector addresses, data, and cyclic redundancy check (CRC) bytes. The actual track formats that are supported are the single-density (FM) and the double-density (MFM).

The standard data character is an 8-bit byte and can be any code. However, for IBM basic data exchange compatibility, this byte should be in EBCDIC code.

Figures 2-4 and 2-5 illustrate the FM and MFM track formats, respectively.

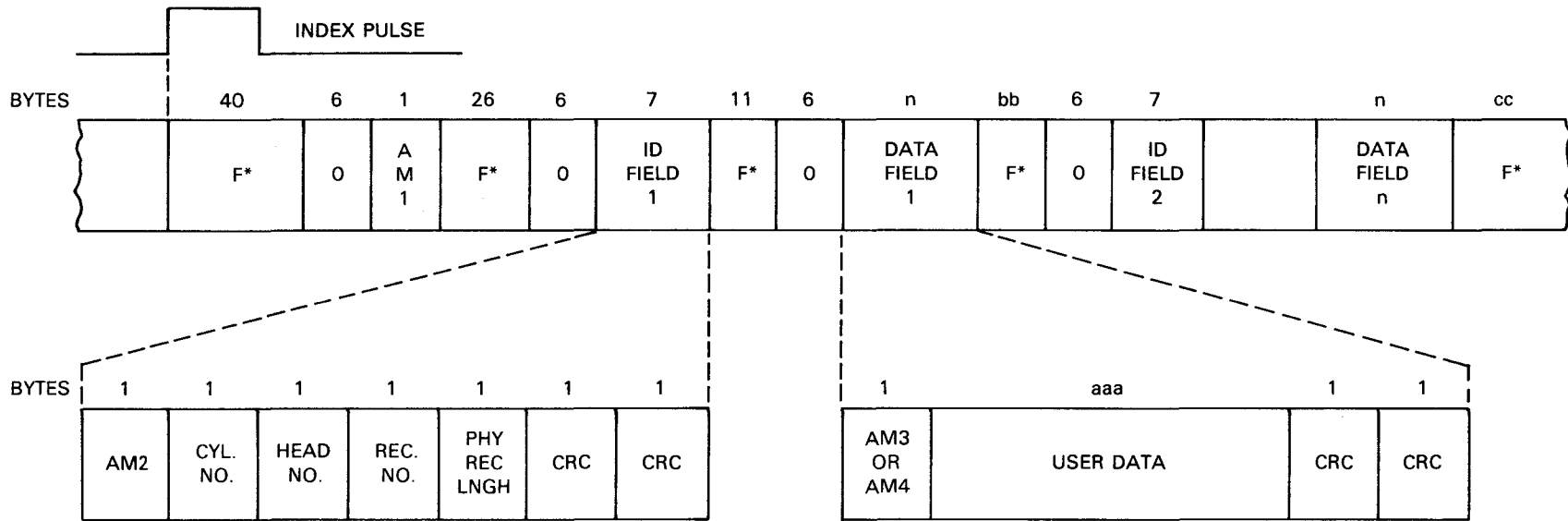

	TYPE	CLOCK	DATA
AM1	INDEX	HEX "D7"	HEX "FC"
AM2	ID	HEX "C7"	HEX "FE"
AM3	DATA	HEX "C7"	HEX "FB"
AM4	CONTROL	HEX "C7"	HEX "F8"

aaa	bb	cc
128	27	247
256	42	170
512	58	311

* This field may contain all zero bytes.

Figure 2-4. FM Track Format

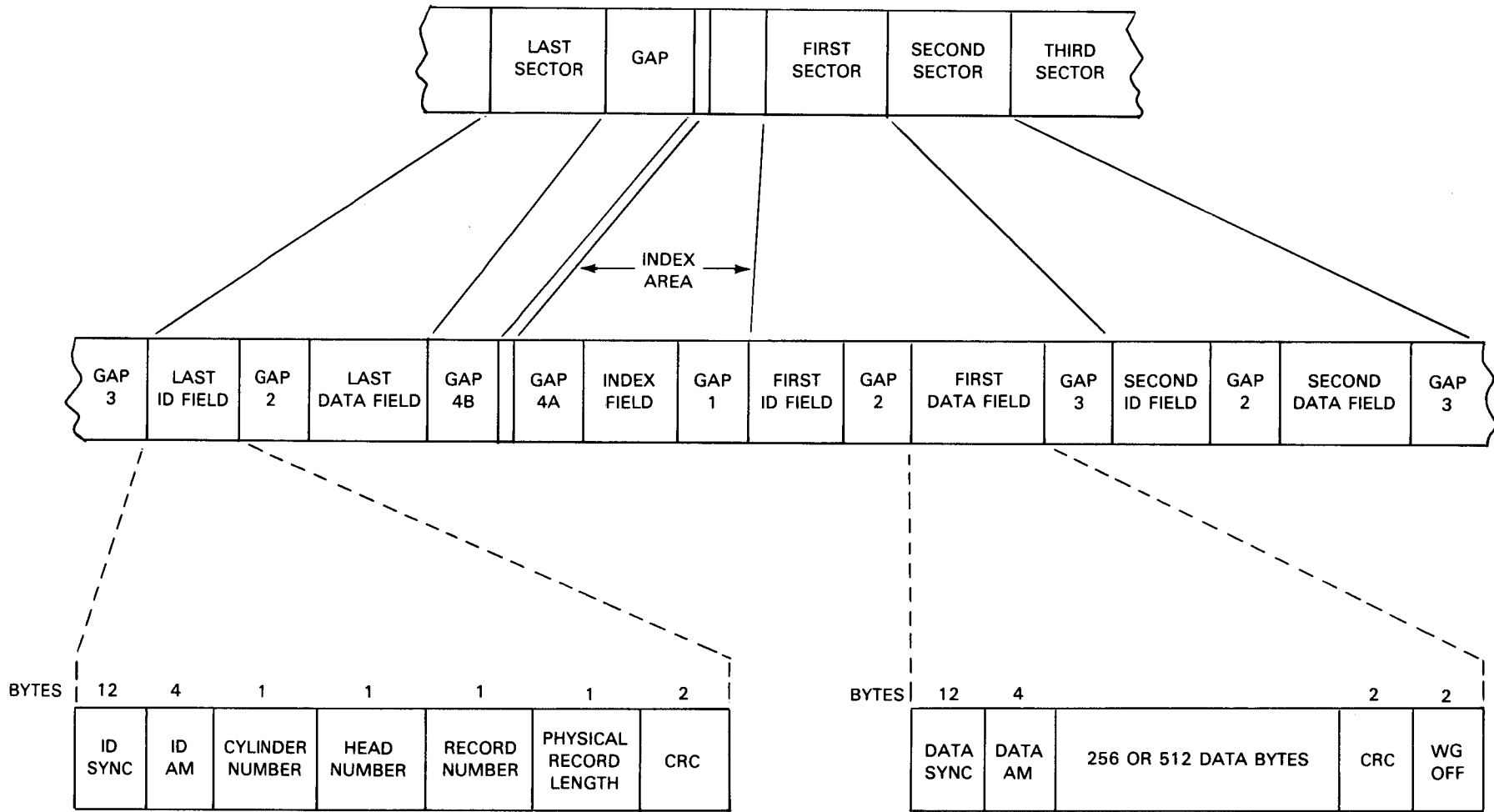

Figure 2-5. MFM Track Format

2.7. DATA TRANSFER RATE

The data transfer rates are highly dependent on the sector sequence arrangement that is employed on the particular diskette and on how the tracks are processed. They also depend upon the number of buffers that are available in the subsystem. There is a possible performance degradation down to 360 records per minute when using the 512-byte format, due to the single record buffer.

The Sperry Univac spiral format provides a sequential arrangement in which, on each successive track, the first sector (01) and all subsequent sectors are physically displaced from the last sector of the preceding track. This format eliminates wasting one full latency time when stepping from one track to the next, provided that the time for the number of sectors physically displaced equals the head step time.

When the standard sequential arrangement of 1 through 26 is employed and the tracks on each side are processed alternately before stepping, the maximum data rates are obtained. These data rates are given in Table 2-4.

Table 2-4. Data Transfer Rates for Diskettes

		One Side (Records per Minute)		Two Sides (Records per Minute)	
		No Spiral	Spiral *	No Spiral	Spiral *
Read	FM 128/26	4670	8125	6225	8690
	FM 256/15	2695	4750	3590	5050
	FM 512/8	1440	2550	1915	2700
	MFM 256/26	4670	8125	6225	8690
	MFM 512/15	2695	4750	3590	5050
Write	FM 128/26	3115	4345	3735	4500
	FM 256/15	1800	2525	2150	2600
	FM 512/8	960	1350	1150	1390
	MFM 256/26	3115	4345	3735	4500
	MFM 512/15	1800	2525	2150	2600

* Assumes that the spiral offset equals:

- 4 sectors for the 26 sectors per track format
- 2 sectors for the 15 sectors per track format
- 1 sector for the 8 sectors per track format

3. Software Control

3.1. GENERAL

The hardware capabilities of the diskette subsystems are directed by a comprehensive set of programming packages. This allows the user to define and configure a logical input/output control system for meeting processing requirements.

3.2. COMMAND REPERTOIRE

The commands in Table 3-1 are issued by the processor to the diskette subsystem. The subsystem rejects any other command and returns a unit-check status presentation to the processor.

Table 3-1. Commands (Part 1 of 2)

Command	Mnemonic	Description
Sense	SNS	Transfers bytes of data to the processor indicating the condition of the subsystem.
Feed	FD	Used with the autoloader causing it to initiate an unload and load sequence of one diskette from the drive into the stacker, and another diskette from the hopper into the drive.
Format Write	FW	Divides tracks into sectors, and writes the ID and preamble field for each sector.
Load Track/ Side/Sector	LTSS	Indicates the next sector to be processed.
Data Set Open	DSO	Conditions the subsystem to process a sequentially organized data set; subsystem enters DSM.
Data Set Close	DSC	Used to exit from the DSM and causes the subsystem to enter the DAM; data set label parameters can be updated.
Read	R	Transfers diskette data to processor except when preceded by a control address mark.
Read Control	RC	Transfers diskette data to the processor and indicates when a control address mark is received.
Write	W	Transfers processor data onto a diskette.

Table 3—1. Commands (Part 2 of 2)

Command	Mnemonic	Description
Write Control	WC	Transfers data to a diskette and puts a special code into the address mark field preceding this data.
Diagnostic Read Subsystem Area	RSA	Transfers up to 256 bytes from the subsystem RAM control area to the processor.
Diagnostic Read Subsystem Buffer	RSB	Transfers up to 768 bytes from the subsystem RAM sector buffer area to the processor.
Read Volume ID	RVID	Obtains the volume ID record from track 0, side 0, sector 7.
Diagnostic Write Enable	DWE	Enabling command for all other diagnostic write commands.
Diagnostic Write Subsystem Buffer	WSB	Loads the subsystem sector buffers with known data.
Recover	RCVR	Used as part of an error recovery operation for R, RC, W, and WC commands.
Initial Load	IL	Allows the processor to position the diskette read/write head to the <i>load point</i> and begin reading data.
Unload	UNLD	Causes the autoloader to initiate an unload sequence of one diskette from the device to the stacker.
No Operation	NOP	Used for test purposes; indicates that the addressed device is installed.
Format Read*	FR	Obtains the ID field bytes from a particular track and diskette side.
Load Physical Track	LPT	Permits read/write head of addressed drive to be loaded for a duration of 3 seconds at a host designated physical track, and enables the host selected read heads. Also used to clean heads when using the special type cleaning diskette.

* MFM version only

3.3. STATUS BYTE

The status and sense bytes are listed in Table 3-2. Status and sense bytes supply information to the processor pertaining to the state of the subsystem.

3.4. SENSE BYTES

Table 3-2 lists the sense bytes as well as status byte. Sense bytes are sent to the processor by the diskette subsystem in response to a sense command or following an abnormal status bit (autosense).

Table 3—2. Status and Sense Bytes

	Status Byte	Sense Byte 0	Sense Byte 1	Sense Byte 2	Sense Byte 3	Sense Byte 4	Sense Byte 5	Sense Byte 6	Sense Byte 7
Bit 0 (MSB)	Attention	Command Reject	Illegal Media	No Data Separator Lock Error	DSL not Found	Autoloader Unload Cycle	MB0*	TA0 (MSB)	L Side Zero
Bit 1	Status Modifier	Intervention Required	Invalid Mode	Side Error	DSL Invalid	Autoloader Feed Cycle	MB1*	TA1	SA0 (MSB)
Bit 2	Control Unit End	Bus Out Check	Invalid Sequence	Track Error	Control AM	Autoloader Stack Full	MB2*	TA2	SA1
Bit 3	Busy	Equipment Check	Invalid Parameter	Record Length Error	DSL WP' Error	Autoloader Hopper Empty	H Autoloader Installed	TA3	SA2
Bit 4	Channel End	Data Check	Not Installed	Sector Error	Disk Parity Error	Autoloader Hang	H Two-Sided	TA4	SA3
Bit 5	Device End	Not Used	Parity Error	ID CRC Error	EOD/EOE	Autoloader Busy	H MFM Density	TA5	SA4
Bit 6	Unit Check	Bus In Check	Stop State Error	Data CRC Error	Read Check Error	Autoloader Jam	H FM Density	TA6	SA5
Bit 7 (LSB)	Unit Exception	Program Alert	Interlock Error	Retry	HWP Error	Data Late	H HWP	TA7	SA6

LEGEND:

CRC = Cyclic Redundancy Check
 DSL = Data Set Label
 EOD = End of Data
 EOE = End of Extent
 H = High
 HWP = Hardware Write Protect
 L = Low
 LSB = Least Significant Bit
 MB = Mode Bit
 MSB = Most Significant Bit
 SA = Sector Address
 TA = Track Address

* Mode Bit (MB) Definition:

	<u>MB0</u>	<u>MB1</u>	<u>MB2</u>	<u>MODE</u>
	0	0	0	DAM
	1	0	0	DSM Read @ BOE
	1	0	1	DSM Read/write @ BOE
	1	1	0	DSM Read/write @ EOD

4. Operator Controls and Indicators

4.1. OPERATOR CONTROLS

No operator controls are used with the manual-load and autoloading diskette drives during operation. All operations are under the control of the system software and controller. Proper installation and removal of the diskettes and clearing any jam for the autoloading are the only operator requirements.

4.1.1. Manual Load/Unload Requirements

For manual loading or unloading, the operator is required to perform the following operations:

Operation	Description
Load	Press latch release bar; door slides open. Place diskette in slot with relief notches down and label away from the latch. Press diskette down until locked in. Close door of diskette drive.
Unload	Press latch release bar; door slides open and diskette automatically rises for removal.

4.1.2. Autoload/Unload Requirements

For autoloading or unloading, the operator is required to perform the following operations:

Operation	Description
Autoload	Place diskettes in the hopper, with strain-relief notches inserted first and label facing front.
Unload	Remove diskettes by lifting them out of the stacker.

4.2. INDICATORS

4.2.1. LED Indicator

A light-emitting diode (LED) indicator (Figure 4-1), located in the latch release push bar of each manual-load diskette drive, is lit when the door is locked and the drive is in use. When the indicator is lit, the diskette cannot be removed because a read or write operation is in progress.

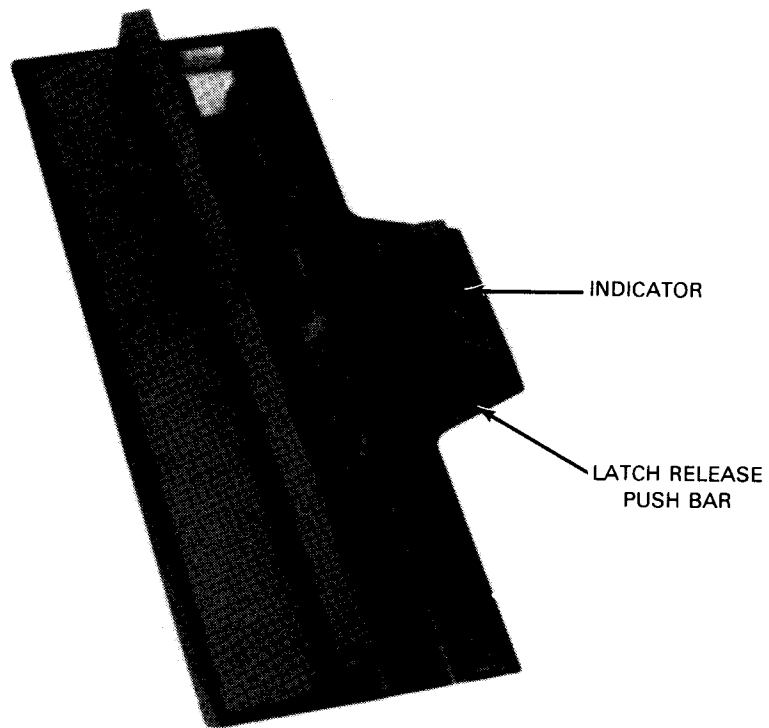

Figure 4-1. Manual-Load Diskette Drive Indicator

4.2.2. Interlock/Reset Switch

This switch is mounted in the autoloader cabinet. Opening the casework trips the switch and power shuts down. Closing the casework:

- activates the switch;
- restores power; and
- recycles the autoloader mechanism to the home feed position.

4.2.3. FEED Switch/Indicator

The FEED switch (Figure 4-2) is used with an autoloader diskette drive to allow an operator-initiated manual feed cycle. It causes an unload and load feed cycle to occur. A lit indicator signifies that a manual feed cycle is in progress.

4.2.4. Drive Read/Write Indicator

The automatically loaded diskette drive uses a red indicator, located near the FEED switch (Figure 4-2), to inform the operator that a read or write operation is in progress. The indicator remains lit while the diskette drive is active.

4.2.5. Other Indicators

All other indicators are supplied by the system and displayed via the messages on the system console workstation.

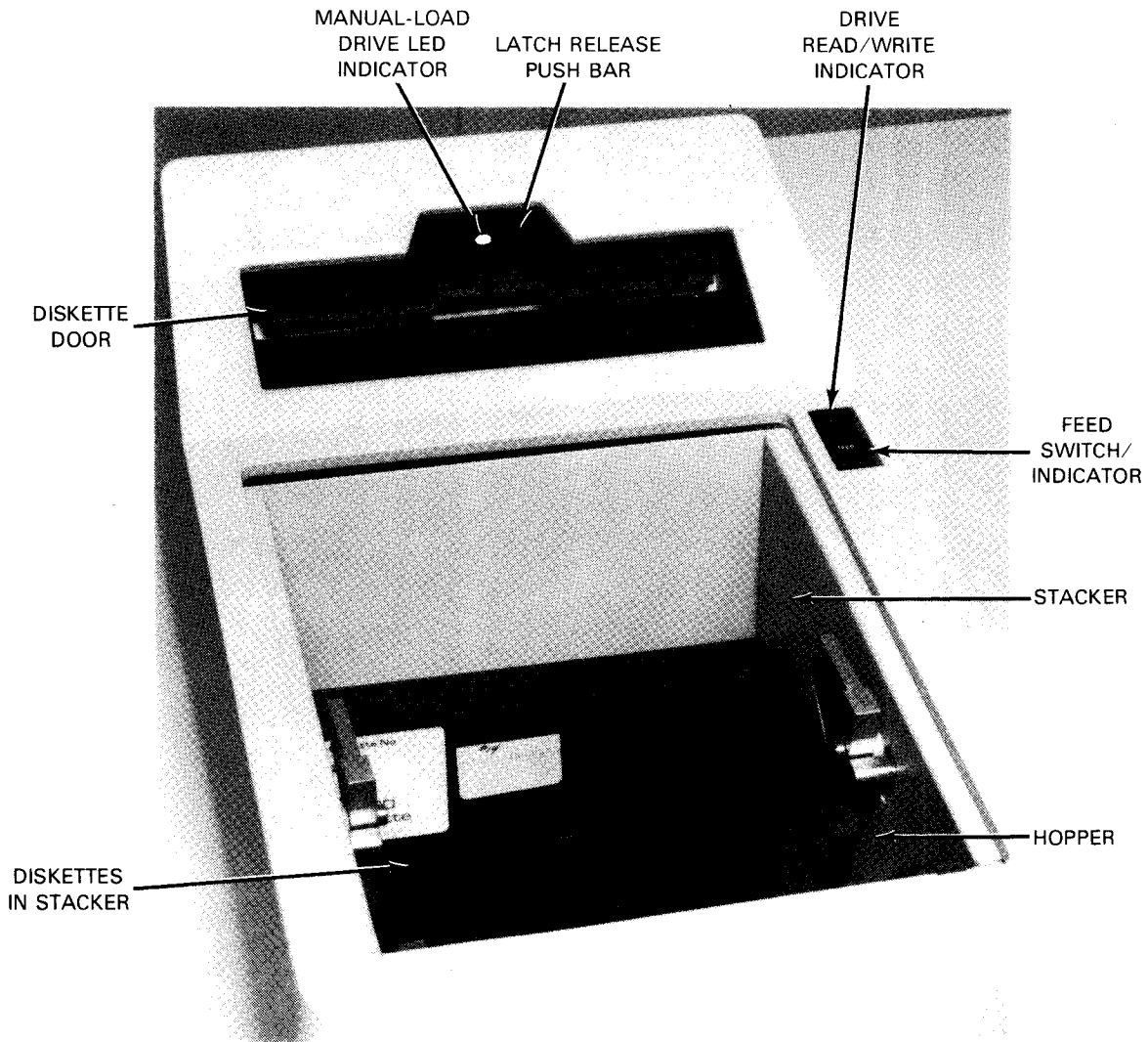

Figure 4-2. Autoload Diskette Drive FEED Switch and Indicator

5. Physical Characteristics

5.1. DIMENSIONS

Figures 5-1 and 5-2 illustrate the physical dimensions of the diskette drive cabinets.

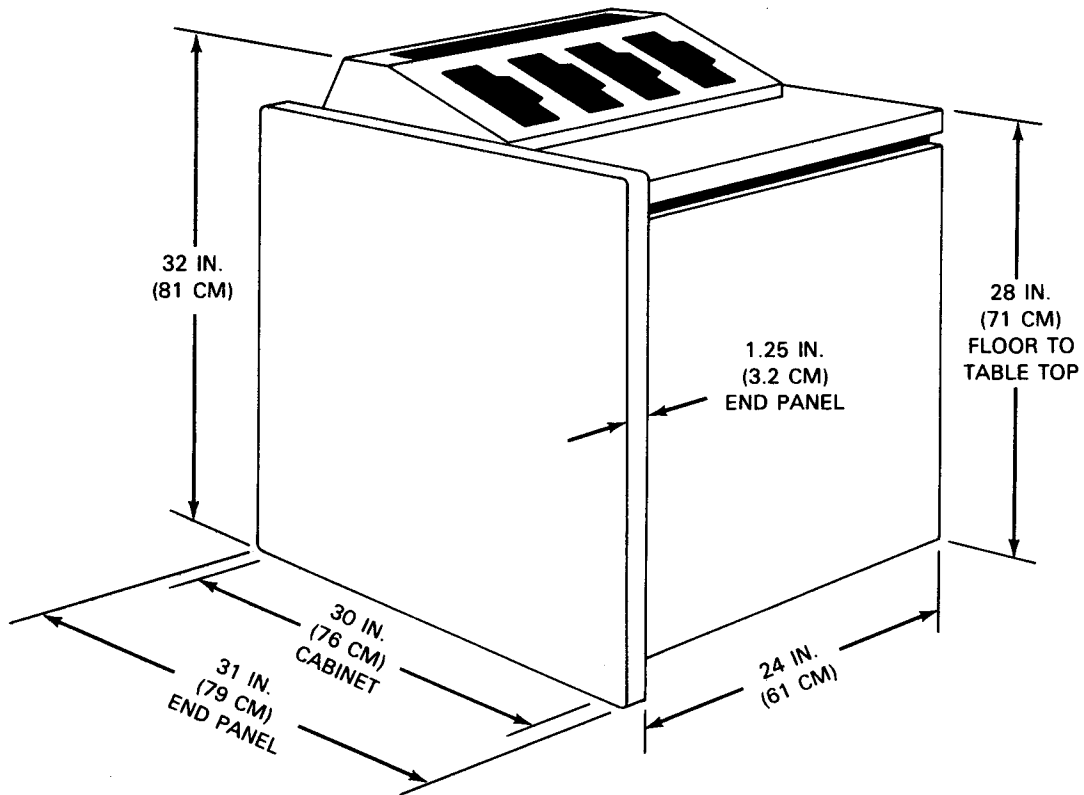

Figure 5-1. Manual-Load Diskette Drive Cabinet

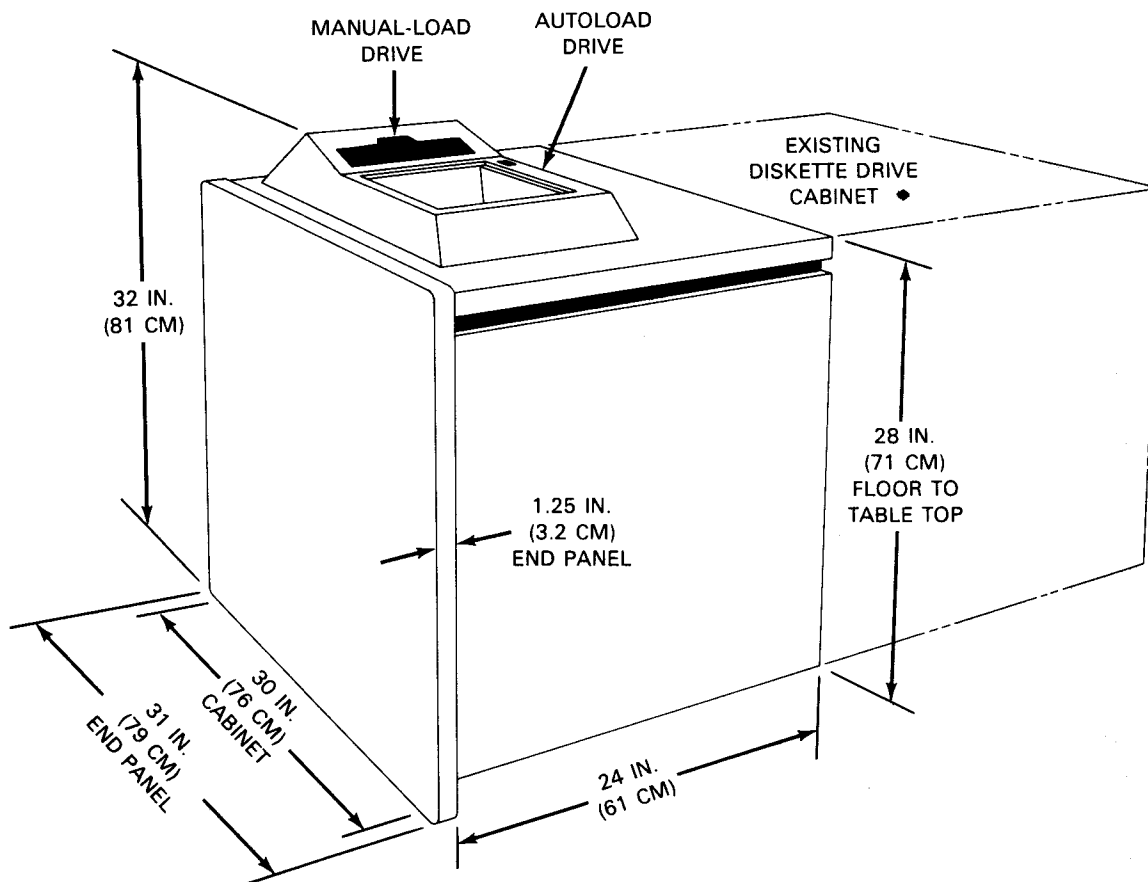

Figure 5—2. Autoload Diskette Drive Cabinet

5.2. ENVIRONMENTAL REQUIREMENTS

The environmental requirements of the subsystem are:

- Shipping and storage range
 - Up to 72 hours (shipping)
 - Temperature: -40° F (-40° C) to 144° F (62° C)
 - Humidity: 1 to 95 percent
 - Up to 6 months (storage)
 - Temperature: -8° F (-22° C) to 117° F (47° C)
 - Humidity: 1 to 95 percent

- Working range

Temperature: 50° F (10° C) to 93° F (34° C)

Humidity: 20 to 85 percent with no condensation

5.3. WEIGHT

Table 5-1 lists the weights for the diskette drive cabinets.

Table 5-1. Diskette Drive Weights

Diskette Drives	Integrated Cabinet (lb)	Extension Cabinet (lb)
1 Manual Load	123 (56 kg)	-
2 Manual Load	140 (64 kg)	-
4 Manual Load	175 (79 kg)	-
1 Autoload	170 (77 kg)	170 (77 kg)
1 Autoload and 1 Manual Load	200 (91 kg)	200 (91 kg)

5.4. HEAT DISSIPATION

The maximum heat dissipations of the diskette drives are listed in Table 5-2.

Table 5-2. Diskette Drive Heat Dissipation

Diskette Drives	Integrated Cabinet (Btu/hr)	Extension Cabinet (Btu/hr)
1 Manual Load	220 (55k cal/hr)	-
2 Manual Load	325 (81.6k cal/hr)	-
4 Manual Load	632 (158.6k cal/hr)	-
1 Autoload	748 (188k cal/hr)	748 (188k cal/hr)
1 Autoload and 1 Manual Load	888 (223k cal/hr)	888 (223k cal/hr)

5.5. POWER REQUIREMENTS

The power requirements for the diskette drives are listed in Table 5-3.

Table 5-3. Diskette Drive Power Requirements

Diskette Drives	Integrated Cabinet (Power From System) (Watts)	Extension Cabinet (Power From System) (Watts)
1 Manual Load	61	-
2 Manual Load	95	-
4 Manual Load	185	-
1 Autoload	219	219
1 Autoload and 1 Manual Load	260	260

5.6. NOISE SUPPRESSION

The diskette drive casework uses the latest acoustical design to provide maximum noise suppression in compliance with National Standard NC55 for Mass Storage Devices.

5.7. DISKETTE HANDLING

A few precautions taken when handling diskette media will assure long trouble-free operation:

- Writing pressure may damage the diskette; therefore, avoid writing on the diskette jacket.
- Avoid bending or attaching paper clips to the diskette.
- Do not clean or touch the diskette surface.
- When you remove the diskette from the diskette drive, replace the diskette into its protective envelope.
- If the diskette envelope is torn or bent out of shape, replace the envelope.
- Avoid placing diskettes near excessive heat or storing them in direct sunlight.
- Be careful to avoid placing the diskette near any magnetized object or near any magnetic field.





