

# 8416/8418 Disk Drives

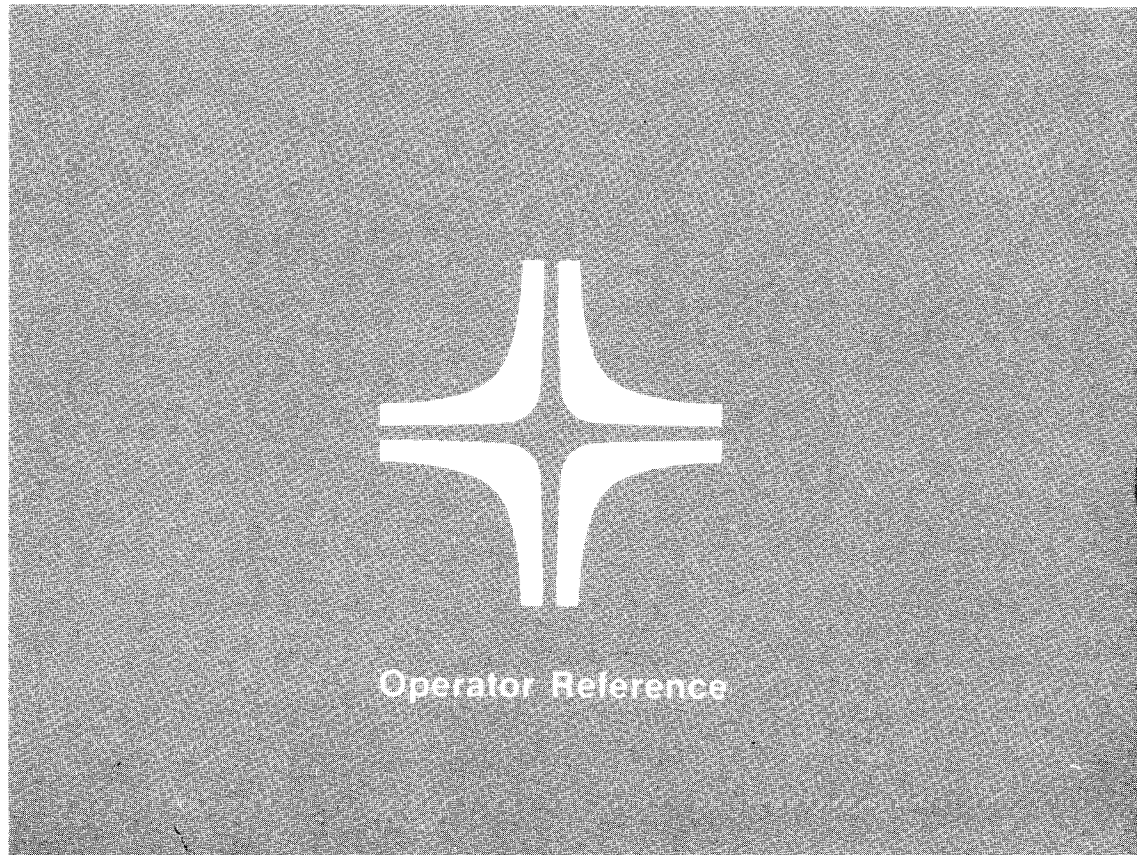

This document contains the latest information available at the time of preparation. Therefore, it may contain descriptions of functions not implemented at manual distribution time. To ensure that you have the latest information regarding levels of implementation and functional availability, please consult the appropriate release documentation or contact your local Sperry representative.

Sperry reserves the right to modify or revise the content of this document. No contractual obligation by Sperry regarding level, scope, or timing of functional implementation is either expressed or implied in this document. It is further understood that in consideration of the receipt or purchase of this document, the recipient or purchaser agrees not to reproduce or copy it by any means whatsoever, nor to permit such action by others, for any purpose without prior written permission from Sperry.

FASTRAND, ✦SPERRY, SPERRY, SPERRY✦UNIVAC, SPERRY UNIVAC, UNISCOPE, UNISERVO, UNIVAC, and ✦ are registered trademarks of the Sperry Corporation. ESCORT, MAPPER, PAGEWRITER, PIXIE, SPERRYLINK, and UNIS are additional trademarks of the Sperry Corporation.

---

The statement below is included in this manual to comply with a Federal Communications Commission (FCC) Regulation. The FCC is an agency of the United States government; thus, the statement below applies to computing equipment installed in the United States of America. Sperry is taking appropriate steps to be in compliance with FCC regulations and similar regulations of other countries.

**WARNING:** This equipment generates, uses, and can radiate radio frequency energy and if not installed and used in accordance with the instructions manual, may cause interference to radio communications. It has been tested and found to comply with the limits for a Class A computing device pursuant to Subpart J of Part 15 of FCC Rules, which are designed to provide reasonable protection against such interference when operated in a commercial environment. Operation of this equipment in a residential area is likely to cause interference, in which case the user, at his own expense, will be required to take whatever measures may be required to correct the interference.

Compliance is based upon a system configuration that includes SPERRY peripherals/subsystems so labeled, and cables furnished by Sperry or built to Sperry specifications and assembly procedures.





# Contents

## PAGE STATUS SUMMARY

### CONTENTS

#### 1. INTRODUCTION

- |      |                           |     |
|------|---------------------------|-----|
| 1.1. | GENERAL                   | 1-1 |
| 1.2. | OPERATOR RESPONSIBILITIES | 1-2 |

#### 2. SUBSYSTEM DESCRIPTION

- |        |                              |     |
|--------|------------------------------|-----|
| 2.1.   | GENERAL                      | 2-1 |
| 2.2.   | SUBSYSTEM COMPONENTS         | 2-1 |
| 2.2.1. | Integrated Disk Control Unit | 2-1 |
| 2.2.2. | Disk Drive                   | 2-1 |
| 2.2.3. | Disk Packs (F1216-01/02)     | 2-1 |

#### 3. CONTROLS AND INDICATORS

- |        |                        |     |
|--------|------------------------|-----|
| 3.1.   | GENERAL                | 3-1 |
| 3.2.   | DISK DRIVE             | 3-1 |
| 3.2.1. | Operator Control Panel | 3-2 |

## 4. OPERATION

4.1.	GENERAL	4-1
4.2.	SYSTEM POWER TURN ON/TURN OFF	4-1
4.3.	DISK DRIVE OPERATION	4-1
4.3.1.	Loading the Disk Drive	4-1
4.3.1.1.	Loading Precautions	4-2
4.3.1.2.	Loading the Disk Pack	4-2
4.3.2.	Unloading the Disk Drive	4-4
4.3.2.1.	Unloading Precautions	4-4
4.3.2.2.	Unloading the Disk Pack	4-4
4.4.	PLACING DISK DRIVE OR SUBSYSTEM ONLINE	4-5
4.5.	PLACING DISK DRIVE OR SUBSYSTEM OFFLINE	4-5
4.6.	RECOVERY PROCEDURES	4-5
4.7.	OPERATOR-PERFORMED MAINTENANCE	4-7

## USER COMMENT SHEET

## FIGURES

1-1.	8416/8418 Disk Drives	1-1
2-1.	Disk Packs (F1216-01/02)	2-2
3-1.	AC Power Box	3-1
3-2.	8416/8418 Operator Control Panels	3-2
4-1.	8418 Disk Drive, Operator Cover Open	4-3
4-2.	8418 Disk Drive, Shroud/Spindle Area	4-3

## TABLES

3-1.	Control Unit Operator Control Panel, Controls and Indicators	3-3
4-1.	8416/8418 Disk Drive Recovery Procedures	4-6

# 1. Introduction

## 1.1. GENERAL

This manual contains the information and procedures for operating the SPERRY 8416/8418 Disk Subsystems. (See Figure 1-1). Each subsystem consists of an integrated disk control unit (IDCU) in the processor mainframe and from one to eight 8416 or 8418 disk drives. Subsystems containing more than four disk drives have an ac power box (type 2408). A subsystem containing more than two drives may also contain a corner adapter (F1769-01), depending on the configuration.

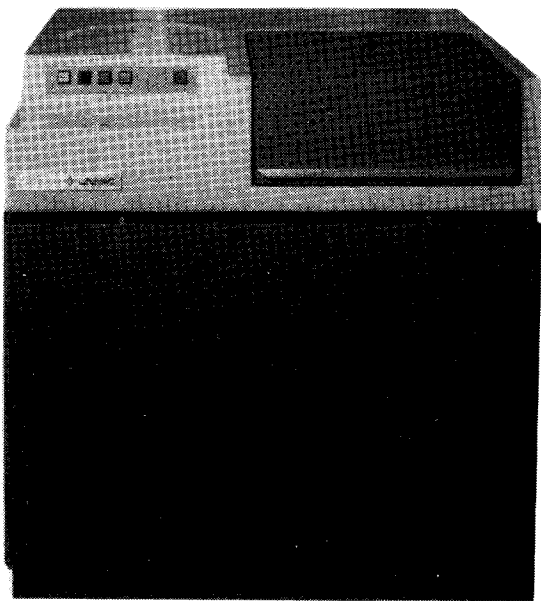

a. 8416 disk drive

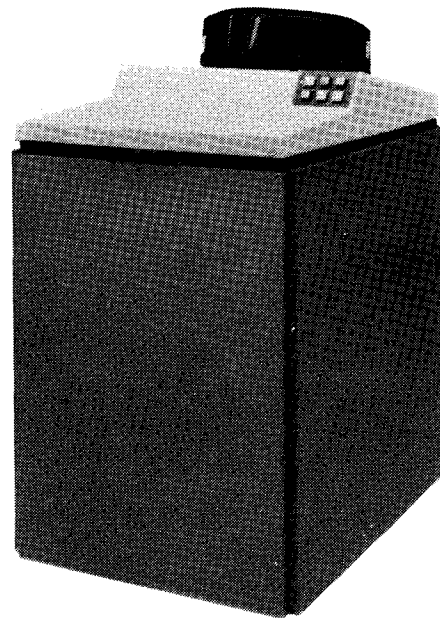

b. 8418 disk drive

Figure 1-1. 8416/8418 Disk Drives

## 1.2. OPERATOR RESPONSIBILITIES

The operator prepares the disk drive for operation and performs the routines required for efficient operation. To assume such responsibilities, the operator must know the locations and functions of all operator-oriented controls and indicators involved in daily use of a drive. The operator must:

- Turn on and turn off the disk drive, as required
- Observe and respond to fault indications
- Load and unload disk packs



## 2. Subsystem Description

### 2.1. GENERAL

The basic 8416/8418 disk subsystem comprises an integrated disk control unit (IDCU) and from one to eight 8416/8418 disk drives.

### 2.2. SUBSYSTEM COMPONENTS

Components of the disk subsystem include the IDCU, disk drives, and the disk packs.

#### 2.2.1. Integrated Disk Control Unit

The IDCU provides the data and control interface between the disk drives and the processor I/O interface. The IDCU resides in the processor mainframe.

#### 2.2.2. Disk Drive

The disk drive is a high-speed direct or random access storage device containing a single disk pack. The upper portion of the disk drive cabinet contains the operator controls and a removable disk pack, as well as the drive motor, and accessing head assemblies. The center and bottom portions of the cabinet include the read/write and control circuitry (essentially all located on printed-circuit boards installed in a card cage), the filtered air supply, the power control panel, and the power supply.

#### 2.2.3. Disk Packs (F1216-01/02)

The disk pack installed by the operator on the drive is the storage medium for up to 57.9 million 8-bit bytes of fixed-length data records. Disk packs are interchangeable among like drives. However, an 8418 disk pack must not be interchanged with an 8416 disk pack. Nor can an 8416 disk pack be interchanged with an 8418 disk pack. Each disk pack weighs approximately 8 pounds (3.6 kilograms) and contains four recording disks (Figure 2-1). Seven of the eight disk surfaces are used for data recording; one surface is used for servo reference information required in head positioning. A circular protective plate is mounted above the top disk and under the bottom disk.

Eight heads are mounted on a single accessor mechanism, seven for writing and reading data, and one for reading servo information. The heads move in unison between the peripheral and the central area of each disk. Each data recording surface is assigned one of the seven read/write heads. Type 8418-94/95 can assume any of 815 track positions (808 data tracks + 7 spare tracks); the type 8418-92/93 can assume any of 411 track positions (404 data tracks + 7 spare tracks). Type 8416 can assume any of 407 primary track positions; 7 tracks are spares.

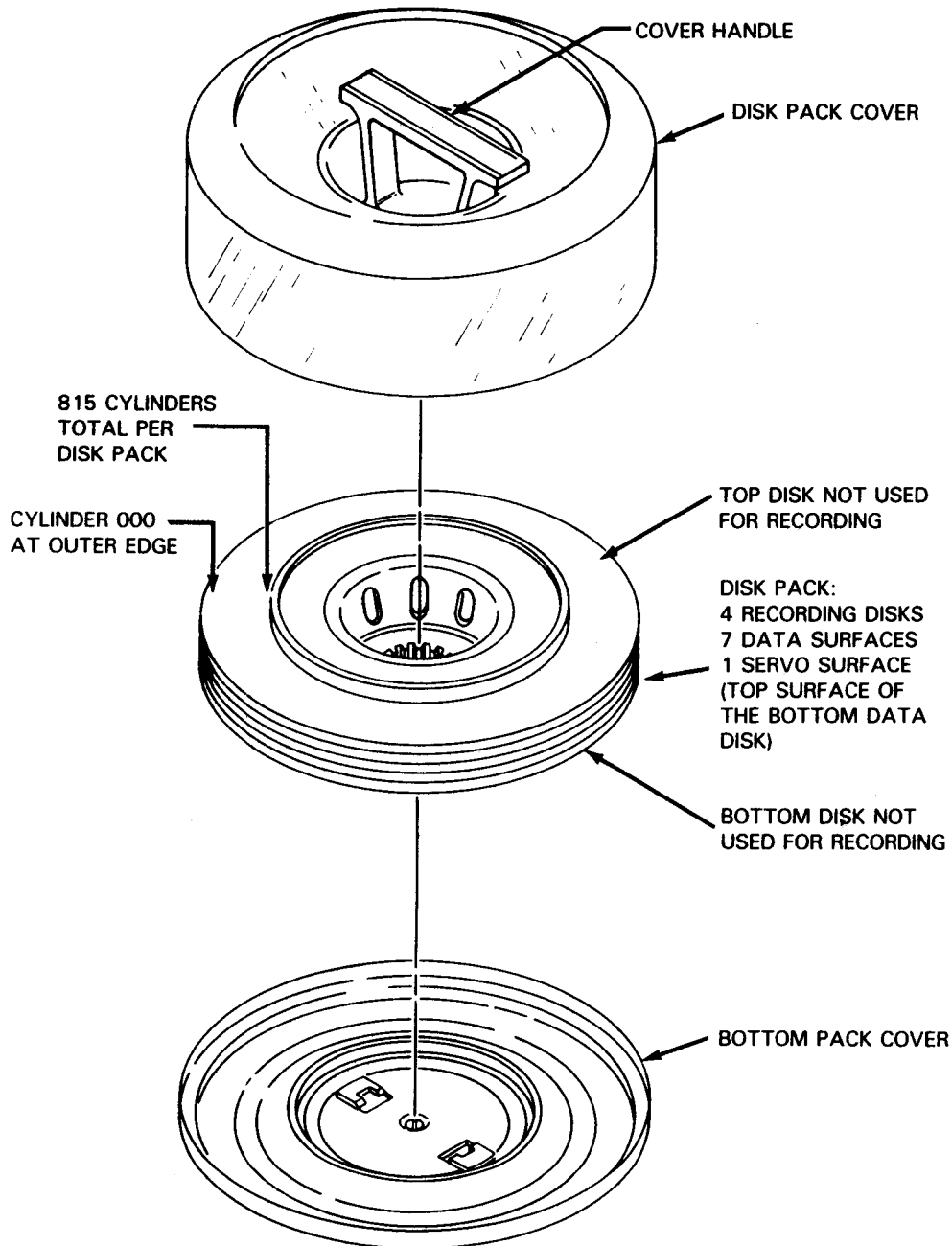

**NOTE:**  
EACH CYLINDER POSITION INTERSECTS  
A DISK DATA SURFACE TO ESTABLISH  
A TRACK LOCATION

Figure 2-1. Disk Packs (F1216-01/02)

## 3. Controls and Indicators

### 3.1. GENERAL

The operating controls and indicators of the 8416/8418 disk drives are located on the operator control panel of each drive. The IDCU is located at the processor and has no operating controls or indicators.

### 3.2. DISK DRIVE

Each disk drive contains an operator control panel located on the upper right corner at the front of the cabinet (8418) or at the left of the disk well (8416). Device addresses are established by the Sperry customer engineer at the time of installation. Subsystems using more than four disk drives require that an ac power box (Figure 3-1) be located between the fourth and fifth disk drives.

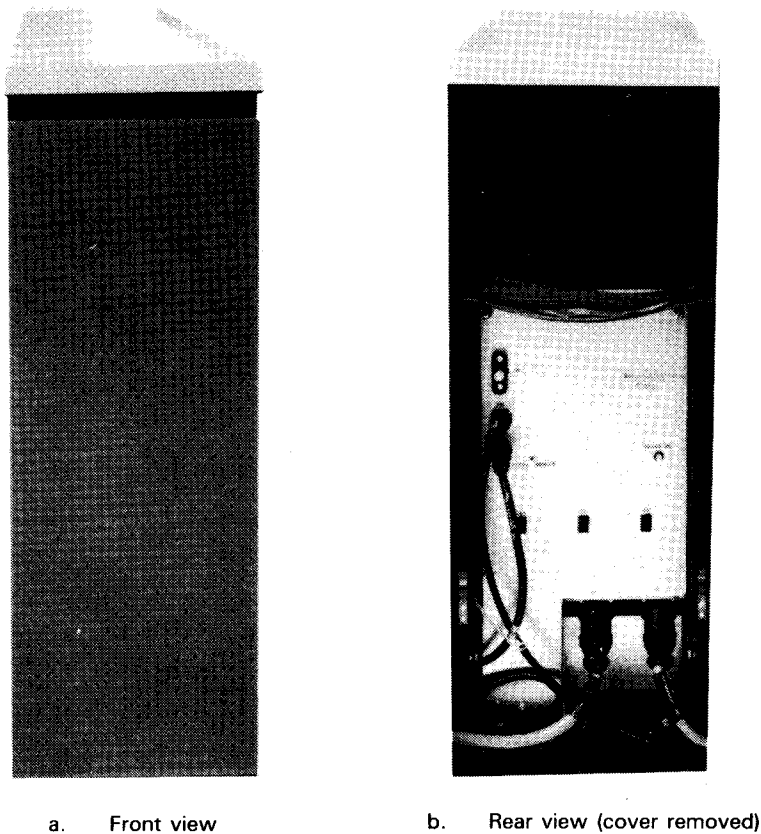
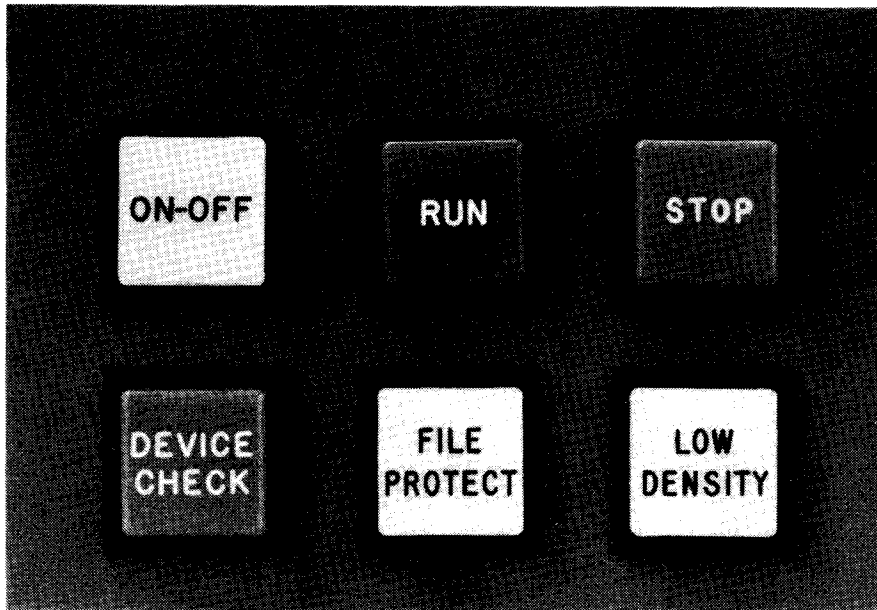

Figure 3-1. AC Power Box

### 3.2.1. Operator Control Panel

The 8418 operator control panel (Figure 3-2a) is located on the upper right side of the disk drive. The 8416 operator control panel (Figure 3-2b) is located to the left of the disk well. Table 3-1 describes the function of each control and indicator. Note that the LOW DENSITY switch/indicator (Figure 3-2) is used on type 8418-92/93 only. The indicators are backlighted.



a. 8418 operator control panel

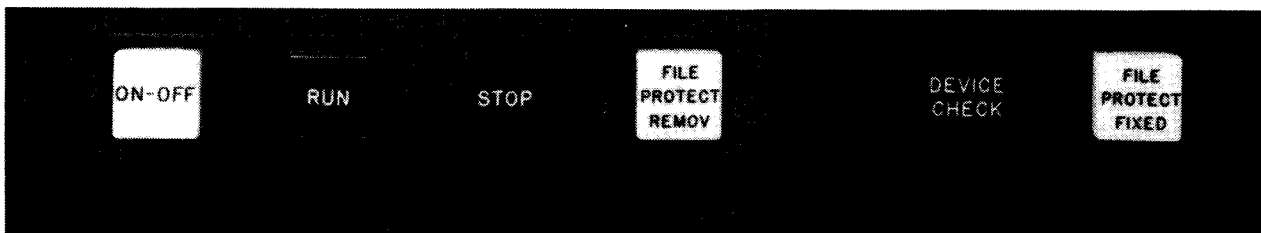

b. 8416 operator control panel

Figure 3-2. 8416/8418 Operator Control Panels

Table 3-1. Control Unit Operator Control Panel, Controls and Indicators (Part 1 of 2)

Control/Indicator	Function
ON-OFF switch/indicator	<p>Applies power to the drive motor. When set to OFF, the ON-OFF indicator blinks until the spindle has stopped.</p> <p>If the cover is not closed or a disk pack is not mounted when the ON-OFF switch is pressed to ON, the ON-OFF indicator is not lit and the STOP indicator blinks. When the cover is closed after the switch is pressed ON, the normal power-on sequence continues.</p> <p>If the drive motor temperature increases, a thermal switch turns off power to the motor until the drive motor has cooled to a safe level. While the thermal switch is open, the ON-OFF switch/indicator remains lit if in the ON position, or extinguishes if in the OFF position, but power to the motor remains off until the motor has cooled.</p>
RUN switch/indicator	<p>Lights when pressed if ON-OFF indicator is lit, and:</p> <ol style="list-style-type: none"> <li>1. disk pack is loaded;</li> <li>2. cover is closed;</li> <li>3. drive spindle is at operating speed;</li> <li>4. heads are loaded at track 00; and</li> <li>5. DEVICE CHECK indicator extinguishes.</li> </ol> <p>If these conditions are met, the RUN indicator lights and the STOP indicator extinguishes. At this point, the ON-OFF and RUN indicators are both lit and the disk drive is ready for system operation.</p> <p>If the RUN switch is pressed and released before these conditions are met, the STOP indicator extinguishes as soon as the RUN switch is released and the RUN indicator lights only after all these conditions have been satisfied.</p>
STOP switch/indicator	<p>Lights to indicate ac power is applied to the disk drive. When pressed, indicator lights and removes the communication link between the integrated control unit and the subsystem. When pressed and held, provides a lamp test for all operator panel lamps.</p> <p>The STOP switch/indicator blinks if a disk pack is not mounted or the cover is not closed when the ON-OFF switch is pressed ON.</p> <p>Certain error conditions that cannot be reset by the system cause the RUN indicator to extinguish and DEVICE CHECK and STOP indicators to light.</p> <p>If an operation is in progress when the STOP switch is pressed, that operation continues to completion before the switch function is activated.</p>
DEVICE CHECK indicator	<p>Lights when conditions are detected within the disk drive that might affect normal operation of the drive. The condition must be cleared before normal drive operation can be resumed.</p> <p>Conditions causing DEVICE CHECK indications are soft unsafes, hard unsafes, and early warning temperature. Soft unsafes are those that can usually be reset by the system. If the soft unsafe cannot be cleared by recovery procedures initiated by the system, the unsafe is considered to be hard. A hard unsafe requires operator intervention at the disk drive.</p> <p>To reset a hard unsafe condition, the operator turns the disk drive off and then on again. If the DEVICE CHECK recurs immediately, corrective maintenance is required; contact Sperry customer engineer.</p>

Table 3-1. Control Unit Operator Control Panel, Controls and Indicators (Part 2 of 2)

Control/Indicator	Function
DEVICE CHECK indicator (cont)	The DEVICE CHECK indicator is lit for any early warning temperature indication or any unsafe condition (soft or hard). A hard unsafe causes the disk drive to go offline. When the disk drive goes offline, the RUN indicator extinguishes and the STOP indicator and DEVICE CHECK indicator are both lit. A DEVICE CHECK condition cannot be cleared by pressing the RUN or STOP switches. While the DEVICE CHECK condition exists, the affected disk drive cannot be placed in the RUN state.
FILE PROTECT switch/indicator (8418 only)	When lit, write operations are inhibited. If an operation is in progress when the FILE PROTECT switch is pressed, that operation continues to completion before the FILE PROTECT function is activated.
FILE PROTECT FIXED switch/indicator (8416 only)	When lit, write operations are inhibited. If an operation is in progress when the FILE PROTECT FIXED switch is pressed, that operation continues to completion before the FILE PROTECT function is activated.
FILE PROTECT REMOV switch/indicator (8416 only)	When lit, write operations are permitted. The FILE PROTECT REMOV switch cancels the effect of the FILE PROTECT FIXED switch.
LOW DENSITY switch	Used only on types 8418-94/95 disk drives. When LOW DENSITY mode is in effect, only tracks 00 through 410 can be accessed. Reading and writing can be done on these tracks. Types 8418-92/93 operate exclusively in this mode and do not require this switch.  This switch allows disk packs to be interchanged between disk drives having different track capacities.

## 4. Operation

### 4.1. GENERAL

Operation of an 8416/8418 disk drive includes turning power on and off, placing individual data storage units online and offline, loading and unloading disk packs in the disk drive, and observing and responding to any subsystem fault conditions that occur during daily operation.

### 4.2. SYSTEM POWER TURN ON/TURN OFF

Power is turned on/off from the system processor. AC power is always present in the disk drive unless the power box is used. A power box with circuit breakers is required when more than four disk drives are included in the subsystem. The STOP indicator, when lit, indicates ac power is available to that disk drive.

To remove power from an individual disk drive without removing power from the rest of the system, press the STOP switch/indicator on the operator control panel; then, press the ON-OFF switch/indicator.

**CAUTION**

*During power removal from a disk drive, failure to press the STOP switch/indicator before pressing the ON-OFF switch/indicator causes power transients that may disturb the processor operation.*

### 4.3. DISK DRIVE OPERATION

#### 4.3.1. Loading the Disk Drive

Disk packs must be protected against improper handling and environmental abuse. The operator should use the instructions provided by the disk pack manufacturer as a reference source.

The disk pack, conditioned to room temperature before installation, is carried by the built-in handle on the top cover. A self-locking device in the handle permits removal of the disk pack top cover only when the pack is mounted on the drive. Other precautions are listed in subsequent subsections.

### 4.3.1.1. Loading Precautions

To load the disk drive:

1. Do not drop the disk pack onto the disk drive spindle; the first threads of the spindle may be damaged.
2. Ensure that the protective cover is completely released from the disk pack before attempting removal; an upward pull applied to the drive shaft lock can damage the threads.
3. Avoid excessive loading torque; extra clockwise twisting to ensure that the disk pack is locked on the shaft is not necessary and can damage the spindle threads.

### 4.3.1.2. Loading the Disk Pack

Loading the disk pack in preparation for operation requires operator attention to both the operator controls and the disk pack. Instructions for both the 8416 and 8418 are the same; only the 8418 is discussed.

1. Push and release the cover latch. The cover springs upward (Figure 4-1). Lift the cover to fully expose the spindle area (Figure 4-2). Keep the amount of time the cover is open to a minimum to limit contamination of the pack area by airborne particles.
2. Remove the disk pack bottom cover by squeezing the bottom cover release mechanism.
3. Place the disk pack on the spindle.
4. Turn the disk pack top cover handle in a clockwise direction until it comes to a full stop. Continue to turn the handle, even though the cover may disengage, to ensure that the full stop point is reached.
5. Remove the disk pack cover.
6. Close and latch the disk drive operator cover. Store the disk pack top and bottom covers in the disk pack storage basket on the drive or in a designated area.
7. Press the ON-OFF switch/indicator, then the RUN switch/indicator. When the disk drive reaches operating speed, the RUN indicator lights and the disk unit is ready for operation.

**NOTE:**

*It is not necessary to wait for the disk drive to power up completely before the RUN switch/indicator is pressed. If the ON-OFF switch/indicator and then the RUN switch/indicator are pressed in sequence, the disk drive immediately goes out of the stop state (STOP indicator extinguishes). The disk drive status automatically changes to the run state after the normal power-up cycle is complete.*

8. Set the mode of operation desired by pressing the FILE PROTECT switch/indicator. The read-only mode is set when the indicator is lit.

**NOTE:**

*The mode of operation can be changed at any time; however, the change does not take effect until the current operation has been completed.*



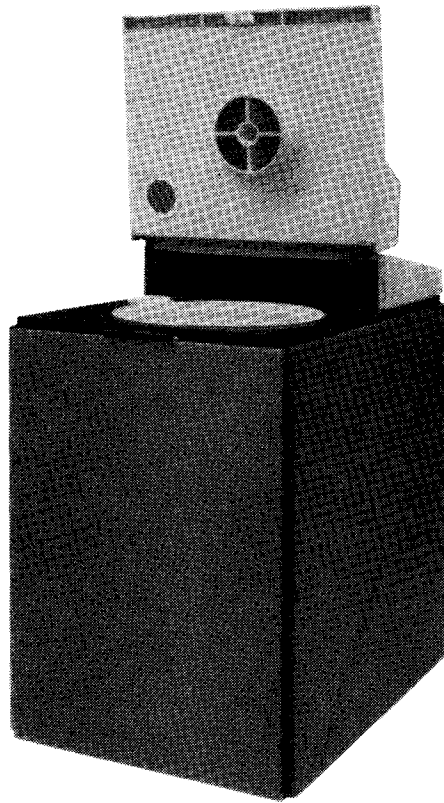

Figure 4-1. 8418 Disk Drive, Operator Cover Open

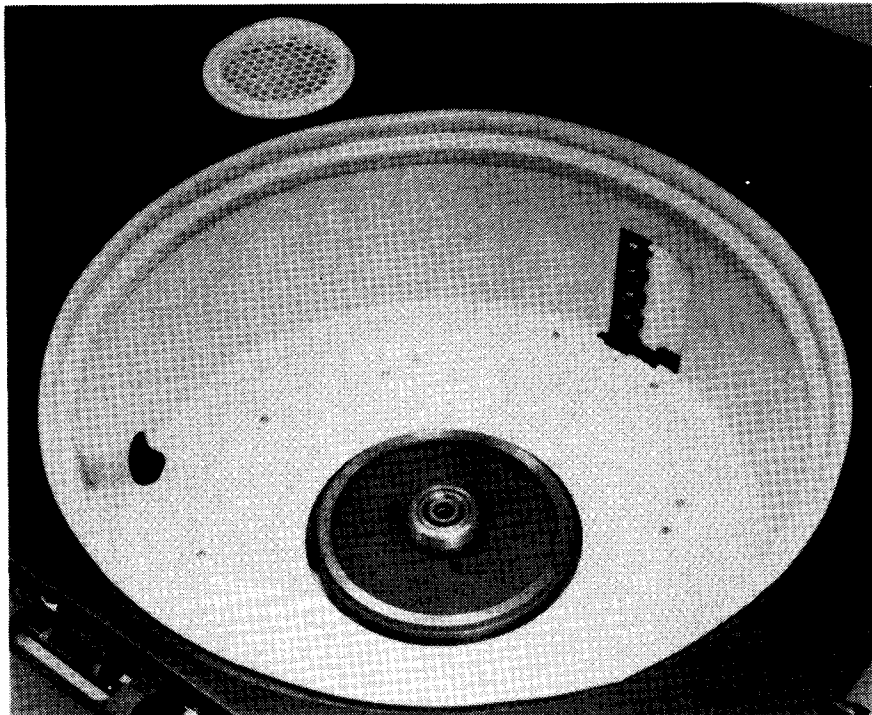

Figure 4-2. 8418 Disk Drive, Shroud/Spindle Area

9. When it is necessary to set the disk drive offline (integrated disk control unit prevented from communicating with the subsystem), press the STOP switch/indicator on the operator control panel. The STOP indicator lights and the RUN indicator extinguishes.

## 4.3.2. Unloading the Disk Drive

### 4.3.2.1. Unloading Precautions

To unload the disk drive, proceed as follows:

1. To prevent damage to the threads, do not attempt to lift the disk pack from the spindle threads until the pack is completely disengaged.
2. A clicking sound can be heard when the spindle releases the disk pack (after the pack is turned counterclockwise for removal); do not permit more than one or two clicks before removing the pack or damage to the threads can result.
3. Store the disk pack in the same environment as the disk drive.

### 4.3.2.2. Unloading the Disk Pack

To remove or replace a disk pack:

1. Press the STOP switch/indicator. Note that all the switch backlights light. When the STOP switch is released, the STOP indicator remains lit. Press the ON-OFF switch; the ON-OFF indicator blinks until pack rotation stops.

**NOTE:**

*A solenoid-operated latch locks the operator cover closed until pack rotation stops.*

2. Once pack rotation stops, release the operator cover latch and lift the cover to fully expose the spindle area.
3. Position the disk pack cover over the pack.
4. Turn the cover counterclockwise for two full turns so that the cover becomes securely fastened to the disk pack, thus forming an integral unit.
5. Remove the disk pack by its top handle.
6. Immediately attach the bottom cover to create a positive dust seal, and store in a designated area.
7. Close and latch the operator cover.

#### 4.4. PLACING DISK DRIVE OR SUBSYSTEM ONLINE

When the subsystem is online, a single disk drive is placed online as follows:

1. Install the correct disk pack (4.3.1.1), if necessary; then close and latch the operator cover. Press the ON switch/indicator first; then press the RUN switch/indicator.
2. At the processor console, provide the operating system with the address of the drive as notice that the drive is to be placed online.

To place an offline powered-up disk subsystem online:

1. Press the RUN switch/indicator at each disk drive.
2. At the processor console, provide the operating system with the addresses of each disk drive to be placed online.

#### 4.5. PLACING DISK DRIVE OR SUBSYSTEM OFFLINE

To place an online disk drive offline:

1. At the processor console, provide the operating system with the address of the disk drive to be placed offline.
2. Press the STOP switch/indicator. Note that the RUN indicator is extinguished and the OFF indicator remains lit after the STOP switch is released.

#### 4.6. RECOVERY PROCEDURES

Operator response to an indicated fault is limited to observing the indication and, in most cases, making one or more efforts to restart the halted operation.

Indicator lamps can be tested by pressing the STOP switch/indicator. All the lamps should be lit while the STOP switch is held pressed. If an indicator does not light, but the proper function occurs, notify the Sperry customer engineer of the condition so it can be corrected at a convenient time.

The DEVICE CHECK indicator is lit when conditions are detected within the drive that might affect normal operation of the disk drive. A DEVICE CHECK (as indicated by the RUN indicator extinguishing and DEVICE CHECK and STOP indicators being lit) caused by a hard unsafe must be cleared before normal drive operation can be resumed. A DEVICE CHECK indicator lit and accompanied by an EARLY WARNING indication at the processor is a signal for operations to be terminated as soon as possible before the temperature problem in the disk drive results in a thermal trip condition.

To reset a hard unsafe generated DEVICE CHECK condition, the operator must turn the disk drive off and then back on and note this occurrence in the system log. If the DEVICE CHECK indication recurs, corrective maintenance is required and the Sperry customer engineer should be notified.

Table 4-1 lists the disk drive malfunctions that may be corrected by the operator. If the malfunction persists after operator intervention, contact the Sperry customer engineer.

Table 4-1. 8416/8418 Disk Drive Recovery Procedures

Fault Indication	Probable Cause	Operator Action
No indicator lit on operator control panel.	Loss of power within subsystem	<ol style="list-style-type: none"> <li>1. Ensure circuit breakers on subsystem ac power box are in the on (up) position. Reset if necessary.</li> </ol> <p>Ensure that the main dc circuit breakers at the processor power control panel are set to their on (up) position. Reset if necessary.</p>
DEVICE CHECK indicator remains lit, RUN indicator off, STOP indicator lit.	Electrical or mechanical malfunction detected	<ol style="list-style-type: none"> <li>1. Hard unsafe detected. To reset, turn disk drive off and then back on. If DEVICE check remains lit, notify Sperry customer engineer.</li> <li>2. Overheating condition detected. Check whether EARLY WARNING indicator is lit at processor.</li> </ol> <p>Check air flow and air filters.</p> <p>Check for excessive recycling of disk drive motors.</p> <p>Allow time for cooling and restart disk drive.</p> <div style="text-align: center; border: 1px solid black; padding: 2px; width: fit-content; margin: 10px auto;">CAUTION</div> <p>If a suspected disk pack or disk drive malfunction requires substitution of the disk pack or disk drive due to a recurring malfunction, do not continue to substitute disk packs or disk drives after the first replacement. A read/write head and/or disk pack crash during a previous operation can cause damage to the heads or disk pack that may cause further damage and eventually disable the entire subsystem if substitutions continue. Contact Sperry customer engineer.</p>
Power loss	Circuit breaker tripped	Set circuit breaker to the OFF position; then reset to the ON position. If circuit breaker trips again, contact Sperry customer engineer.

## 4.7. OPERATOR-PERFORMED MAINTENANCE

Preventive maintenance is performed on an 8416/8418 drive on a periodic basis by Sperry customer engineers. Therefore, operating personnel are not required to adjust, clean, or replace any internal items in the subsystem. External cleaning may be performed at the discretion of the local Sperry maintenance organization. Good housekeeping practices should be observed by keeping contaminants from inside the disk pack and disk well while any cover is open.

Operator-performed maintenance of the subsystem is limited to the following:

- Attempting to restart a disk drive when the DEVICE CHECK indicator on a disk drive indicates an internal problem in the drive. If a DEVICE CHECK condition cannot be cleared from the operator panel, notify the Sperry customer engineer. (See 4.6.)
- Replacing defective indicator lamps in the operator control panel switch/indicators, as follows:
  1. Grasp switch lens and pull forward to remove.
  2. Using a piece of 1/8-inch (4 mm) rubber tubing, slide tubing over bulb, push down, turn counterclockwise, and remove bulb.
  3. Place new lamp into tubing with lamp base protruding from tubing.
  4. Place lamp base into lamp socket using tubing, press in, and turn clockwise. Remove tubing from lamp.
  5. Replace switch lens by pressing it into place.



CUT



## USER COMMENT SHEET

We will use your comments to improve subsequent editions.

NOTE: Please do not use this form as an order blank.

---

*(Document Title)*

---

*(Document No.)*

---

*(Revision No.)*

---

*(Update No.)*

### Comments:

**From:**

---

*(Name of User)*

---

*(Business Address)*

Fold on dotted lines, and mail. (No postage stamp is necessary if mailed in the U.S.A.)  
Thank you for your cooperation

CUT

FOLD

NO POSTAGE  
NECESSARY  
IF MAILED  
IN THE  
UNITED STATES

---

**BUSINESS REPLY MAIL**

FIRST CLASS PERMIT NO. 21 BLUE BELL, PA.

---

POSTAGE WILL BE PAID BY ADDRESSEE

**SPERRY CORPORATION**

ATTN.: SOFTWARE SYSTEMS PUBLICATIONS

P.O. BOX 500  
BLUE BELL, PENNSYLVANIA 19424



FOLD