

IBM

Operator's Guide

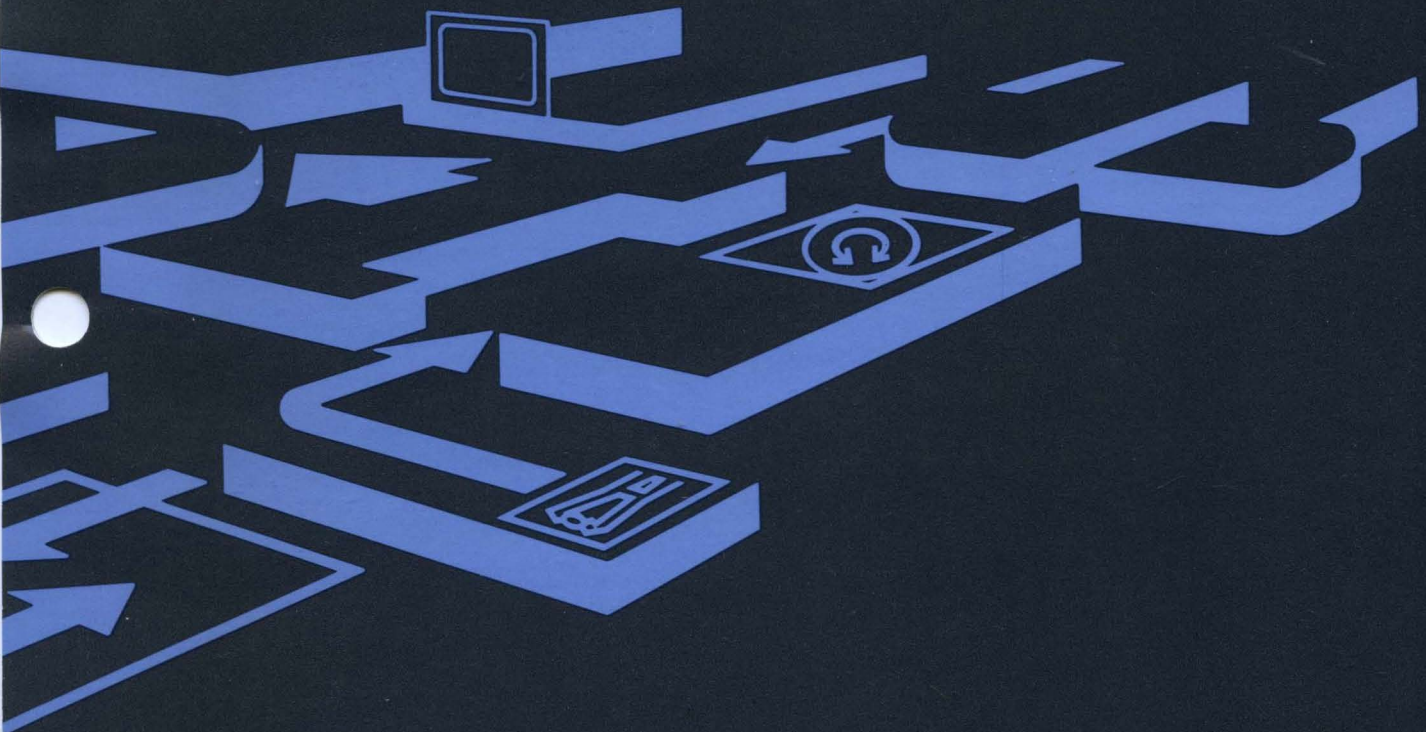

IBM 5531 Industrial Computer

IBM

Operator's Guide

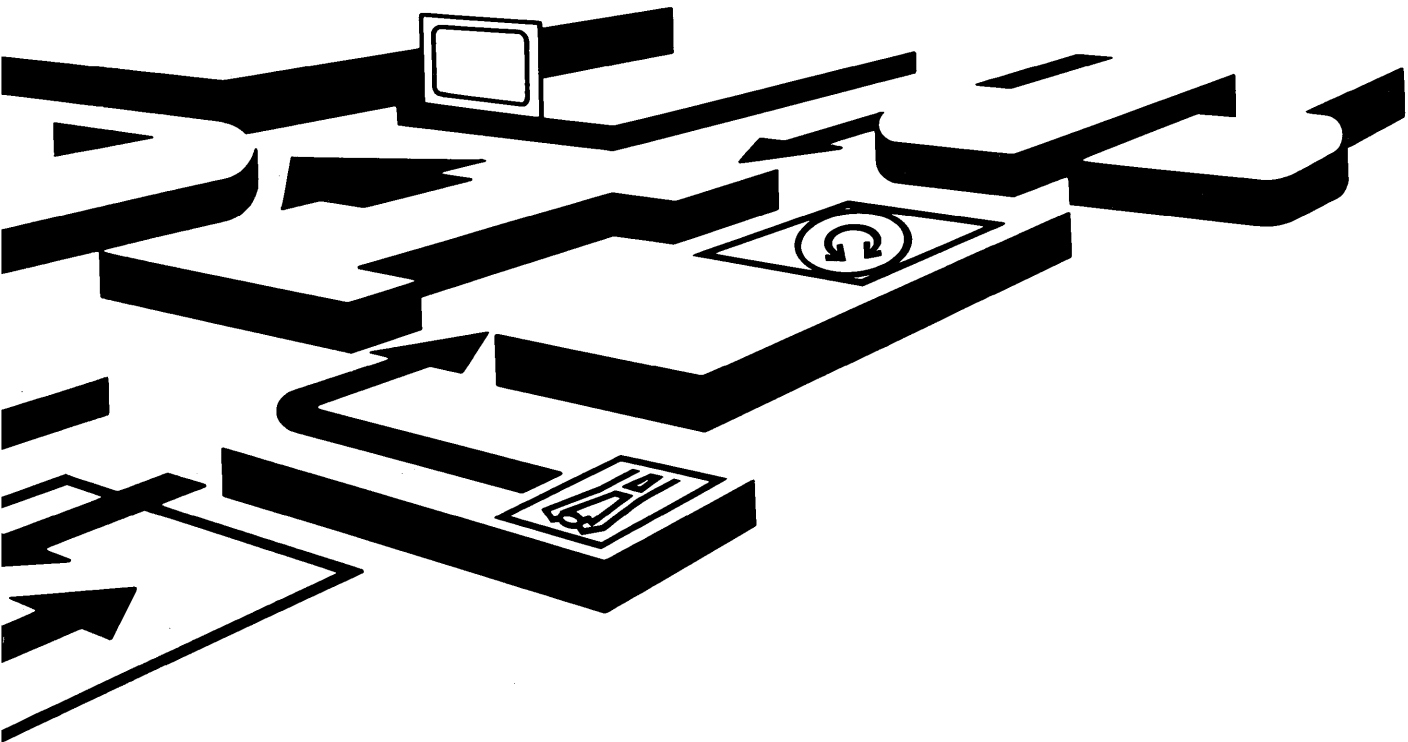

IBM 5531 Industrial Computer

Federal Communications Commission (FCC) Statement

Warning: This equipment generates, uses and can radiate radio frequency energy and if not installed and used in accordance with the instructions manual, may cause interference to radio communications. It has been tested and found to comply with the limits for a Class A computing device pursuant to Subpart J of Part 15 of FCC Rules, which are designed to provide reasonable protection against such interference when operated in a commercial environment. Operation of this equipment in a residential area is likely to cause interference in which case the user at his own expense will be required to take whatever measures may be required to correct the interference.

CAUTION

This product described herein is equipped with a grounded plug for the user's safety. It is to be used in conjunction with a properly grounded receptacle to avoid electrical shock.

First Edition (April 1985)

INTERNATIONAL BUSINESS MACHINES CORPORATION PROVIDES THIS PUBLICATION "AS IS" WITHOUT WARRANTY OF ANY KIND, EITHER EXPRESS OR IMPLIED, INCLUDING, BUT NOT LIMITED TO THE IMPLIED WARRANTIES OF MERCHANTABILITY OR FITNESS FOR A PARTICULAR PURPOSE. Some states do not allow disclaimer of express or implied warranties in certain transactions, therefore, this statement may not apply to you.

This publication could include technical inaccuracies or typographical errors. Changes are periodically made to the information herein; these changes will be incorporated in new editions of the publication. IBM may make improvements and/or changes in the product(s) and/or the program(s) described in this publication at any time.

It is possible that this publication may contain reference to, or information about, IBM products (machines or programs), programming, or services that are not announced in your country. Such references must not be construed to mean that IBM intends to announce such IBM products, programming, or services in your country.

Products are not stocked at the address below. Requests for copies of this publication and for technical information about IBM Industrial Computer products should be made to your authorized IBM Industrial Computer dealer or your IBM Marketing Representative.

The following paragraph applies only to the United States and Puerto Rico:

Address comments to: IBM Corporation, Manufacturing Systems Products, P.O. Box 1328-4327, Boca Raton, Florida 33432. IBM may use or distribute any of the information you supply in any way it believes appropriate without incurring any obligations whatever.

Preface

Audience and Purpose

The *IBM 5531 Industrial Computer Operator's Guide*, part number 6219637, is intended for anyone who is responsible for cabling and operating the IBM 5531 Industrial Computer. This book provides the information you need to cable and operate your IBM 5531 Industrial Computer. It also contains information on how to check for a problem that may occur.

How This Book Is Organized

This book contains five chapters and a glossary of the terms and abbreviations. The book contains the following chapters:

Chapter 1. Introducing the IBM 5531 Industrial Computer. This chapter provides a brief description of the system unit, keyboard, and display. Chapter 1 also shows a typical IBM Industrial Computer configuration.

Chapter 2. Cabling the IBM 5531 Industrial Computer. This chapter provides step-by-step instructions for connecting the cables to the system and running the power-on self-test (POST).

Chapter 3. Diskettes and Utilities. This chapter provides information on handling diskettes, write-protecting diskettes, and inserting and removing diskettes. Chapter 3 also describes the Thermal Warning program.

Preface

How This Book Is Organized (*continued*)

Chapter 4. Checking and Replacing Filters. This chapter provides instructions on checking and replacing the filters on the system unit and on an IBM Industrial Color Display.

Chapter 5. Problem Determination Procedures. This chapter provides steps for correcting problems that may occur. The chapter shows how to check electrical and communications connections, how to adjust screen alignment, and how to correct other problems that may occur.

Appendix A. Option List. The Option List is to be used for determining which options are installed in your system.

How to Use This Book

When using this book, disregard any reference to options or adapters that are not a part of your system. The final configuration of your system depends on your choice of the various options and adapters that are available.

This book is intended to cover options and adapters that may or may not be installed in your system.

Chapters 1, 2, and 3 are meant to be read in order.

Chapter 1 shows you the components of an IBM Industrial Computer system. Once you are familiar with the system, Chapter 2 shows you how to connect the cables. Chapter 3 shows you how to insert a diskette in the diskette drive.

Refer to Chapter 4 when you need to check or replace the filters on the system unit and the display.

Refer to Chapter 5, “Problem Determination Procedures,” to correct problems that occur during system use.

Each of the five chapters has an external tab to help you find the chapter more easily.

Where to Store This Book

Store this book in the *Operator's Guide* binder.

Diskettes Included with This Book

Two diskettes are included with this book. They are in a plastic holder at the back of this book. These diskettes are:

- *Industrial Computer Utilities*, which is used with Chapter 3.
- *Industrial Computer Diagnostics*, which is used with Chapter 5, "Problem Determination Procedures."

Related Publications

Related publications are:

- *IBM 5531 Industrial Computer Installation and Setup Manual*, part number 6523287, which is intended for anyone who is responsible for installing and setting up the IBM 5531 Industrial Computer.
- *IBM 5531 Industrial Computer Maintenance Information*, part number 6219638, which contains detailed problem determination procedures and removal and replacement procedures. This book is intended for someone who has experience with servicing computers.
- *IBM 5531 Industrial Computer Technical Reference, System Unit*, part number 6219639, which is intended for experienced programmers and engineers.
- *IBM Industrial Computer Technical Reference, Options and Adapters* (3-volume set) part number 6523262.

Preface

Reference Publications

You may need to use the following publications for reference:

- *IBM Personal Computer Disk Operating System (DOS)*, Version 2.1 or later
- *IBM Personal Computer BASIC*.

If you install any options in your 5531 Industrial Computer, you should refer to the information that accompanies the option.

Contents

Chapter 1. Introducing the IBM Industrial Computer 1-1

Typical IBM Industrial Computer 1-2

System Unit 1-3

 Front View 1-4

 Rear View 1-4

Keyboard 1-5

 Typewriter Keys 1-6

 Numeric Keypad 1-8

 Function keys 1-10

 Special Key Combination 1-20

 Adjusting the Keyboard Tilt Position 1-11

IBM Industrial Display 1-12

 Front View 1-12

 Rear View 1-13

Options or Adapters for the IBM 5531 Industrial Computer 1-14

Summary 1-14

Chapter 2. Cabling the IBM 5531 Industrial Computer 2-1

Connecting the Cables 2-2

Running the Power-On Self-Test (POST) 2-8

Summary 2-9

Chapter 3. Diskettes and Utilities 3-1

Handling Diskettes 3-2

Write-Protecting a Diskette 3-3

Inserting and Removing a Diskette from the Drive 3-4

 Inserting a Diskette in the Diskette Drive 3-4

Contents

Removing a Diskette from the Diskette Drive 3-5
Thermal Warning 3-8
Summary 3-6

Chapter 4. Checking and Replacing Filters 4-1

System Unit Filter 4-2
 Checking and Replacing the System Unit Filter 4-2
IBM Industrial Color Display Filter 4-4
 Checking and Replacing an IBM Industrial Color Display Filter 4-4

Chapter 5. Problem Determination Procedures 5-1

Checking Electrical Connections 5-1
Checking the IBM Cluster Adapter 5-3
Running the Power-On Self-Test (POST) 5-4
 Industrial Computer POST Errors 5-6
Formatting a Diskette 5-8
Diagnostic Test Error Messages 5-13
System Testing Information 5-14
Loading Diagnostics 5-16
Test 100 -System Unit 5-100-1
Test 300 -Keyboard 5-300-1
Test 400 -Monochrome Display and Printer Adapter 5-400-1
Test 500 -Color/Graphics Monitor Adapter 5-500-1
Test 600 -Diskette Drive 5-600-1
Test 700 -Math CoprocessorS 5-700-1
Test 900 -Printer Adapter 5-900-1
Test 1100 -ASYNCR Adapter 5-1100-1
Test 1500 -SDLC Adapter 5-1500-1
Test 1700 -Fixed Disk Drive 5-1700-1
Test 2000 -BSC Adapter 5-2000-1
Test 2200 - IBM Personal Computer Cluster Adapter 5-2200-1
Test 2400 -Enhanced Graphics Adapter 5-2400-1
Test 3600 -General Purpose Interface Bus Adapter 5-3600-1
Test 3800 -Data Acquisition and Control Adapter 5-3800-1
Test 4700 -Realtime Clock 5-4700-1
Test 1400 -Graphics Printer 5-1400-1

Appendix A. Option List A-1

Diskette Drives A-1
Fixed Disk Drive A-1
Base Memory A-1
Display A-1
Other Options A-1

Terms and Abbreviations X-1

Index X-5

Chapter 1. Introducing the IBM 5531 Industrial Computer

This chapter describes the hardware for the IBM 5531 Industrial Computer. Illustrations identify power controls and power connectors as well as other parts of the hardware. Familiarize yourself with the parts identified in each illustration. Throughout the book, we refer to these parts.

The basic IBM 5531 Industrial Computer consists of a system unit and a keyboard. The system unit contains a dual-sided diskette drive, a Diskette Drive Adapter, a Combination Adapter, 128KB or 256KB of memory, and additional expansion slots. Your system may include a fixed disk drive, a Color/Graphics Monitor Adapter, or other options and adapters.

When reading this book, disregard any reference to options or adapters that are not a part of your system.

The keyboard, which is used to send data to the system, attaches to the system unit with a 2-meter (6-foot) coiled cable. The keyboard consists of three sections: the typewriter keys, the numeric keypad, and the function keys.

Introducing the IBM 5531 Industrial Computer

Typical IBM Industrial Computer

A typical IBM Industrial Computer system consists of a system unit, a keyboard, and a display. The display may be an IBM Industrial Display, or it may be a non-IBM display. The examples used in this book show an IBM Industrial Display.

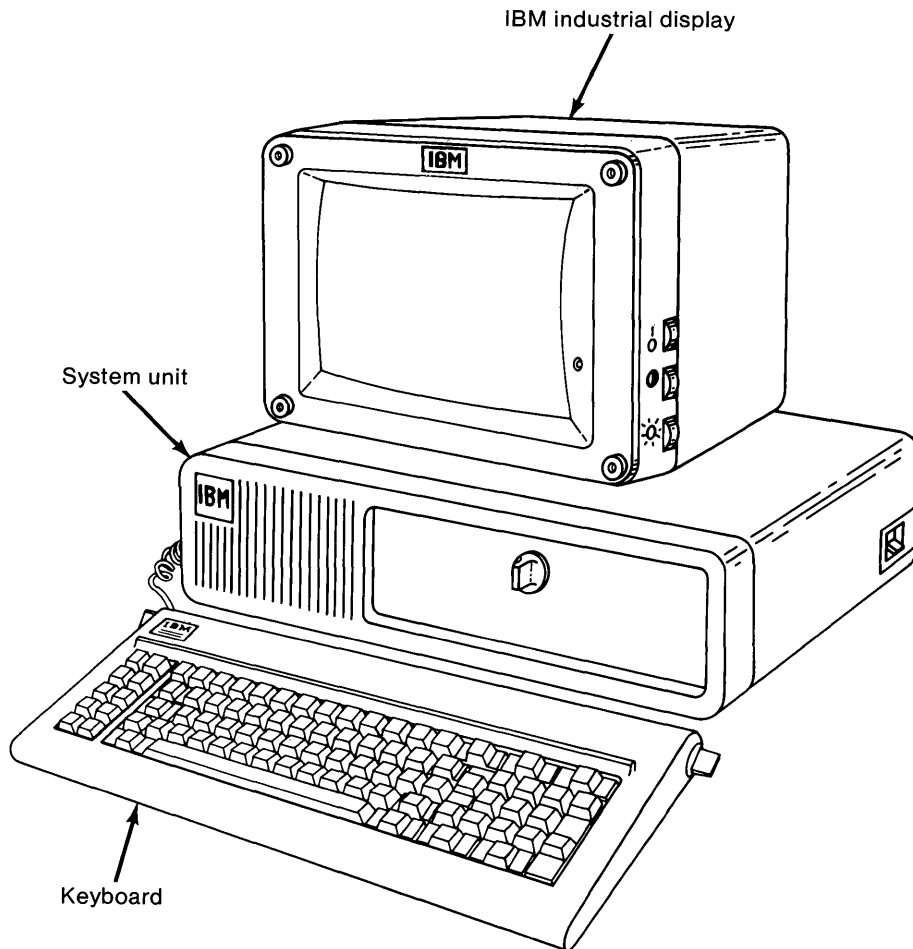

System Unit

The most important part of the IBM 5531 Industrial Computer is the system unit. The system unit controls the operation of your system. It accomplishes this through sets of instructions called programs.

Many of the programs for the 5531 are written in IBM BASIC, a programming language that is already installed in your system. You can also use several other IBM-supported programming languages to write your own programs. You should have an understanding of fundamental programming concepts if you intend to write programs. Various program packages available from your industrial dealer will also help you meet a variety of business and personal needs.

The system unit stores data on either a fixed disk drive or on the diskettes that are used in the diskette drive. The system unit allows you to retrieve data stored on a fixed disk or on a diskette. The set of programs that controls such operations is known as an *operating system*, an example of which is the IBM Disk Operating System (DOS). The reference manuals *IBM Disk Operating System (DOS)* and *IBM BASIC* describe the commands that allow you to store or retrieve information. If you choose to write your own operating system, refer to the *IBM 5531 Industrial Computer Technical Reference*.

The system unit contains at least one diskette drive (referred to as drive A), a Diskette Drive Adapter, and a Combination Adapter.

The Diskette Drive Adapter allows you to use the dual-sided diskette drive that is installed in the system unit.

The Combination Adapter allows you to use asynchronous communications and/or attach a printer to the system unit. This adapter comes configured for primary communications operation and RS-232C asynchronous communications. If you use any other type of communications, you must have the appropriate communications adapter installed. For information on available communications options, see your place of purchase.

For a listing of options or adapters, refer to "Options or Adapters for the IBM 5531 Industrial Computer" near the end of this chapter.

Introducing the IBM 5531 Industrial Computer

System Unit *(continued)*

The following illustrations show a front and a rear view of the system unit. The illustrations identify all important parts of the system unit.

Front View

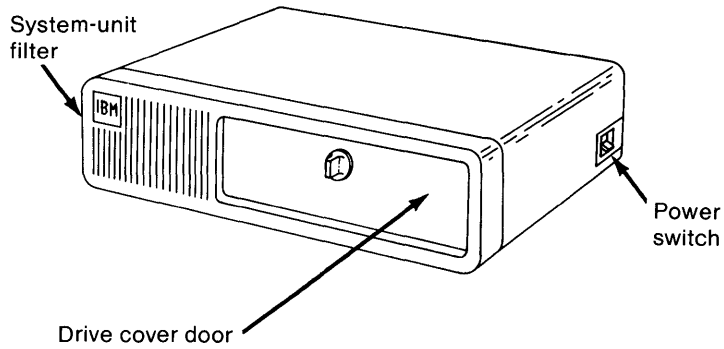

Note: You may or may not have ordered a keylock for the drive cover door.

Rear View

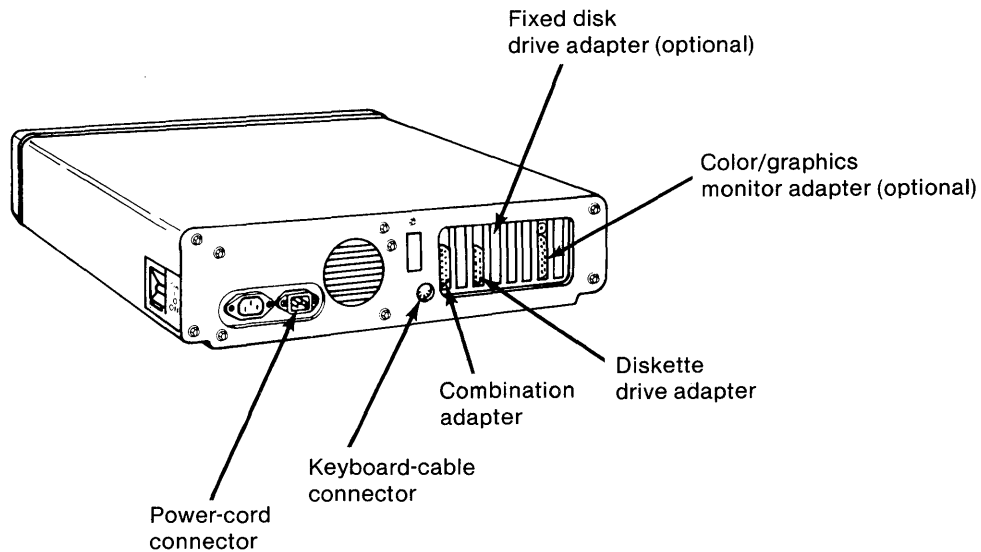

Keyboard

The keyboard connects to the system unit. The keyboard contains three types of keys: the typewriter keys, the function keys, and the keys on the numeric keypad. Familiarize yourself with the keyboard by looking at the illustrations and reading the descriptions of the keys.

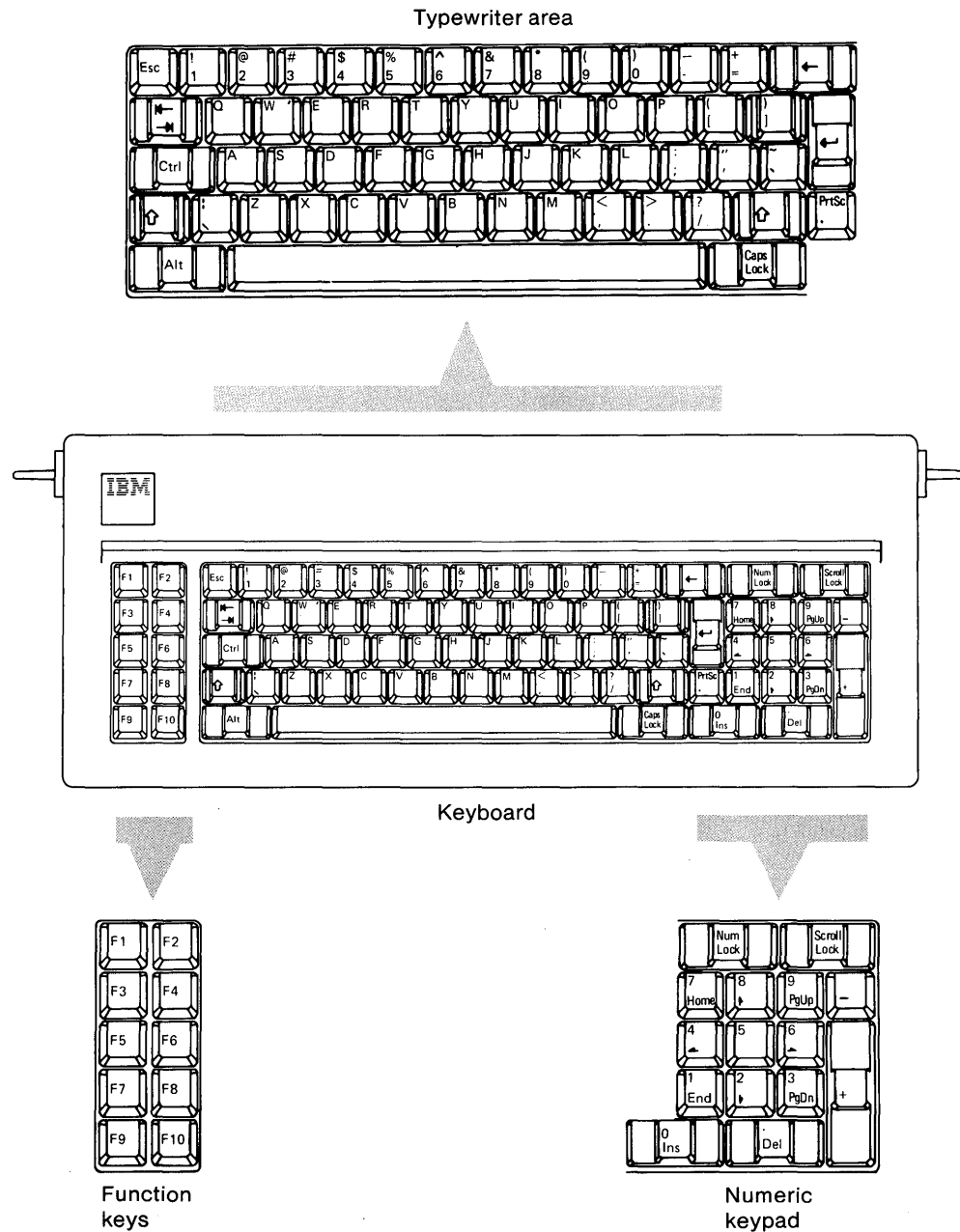

Introducing the IBM 5531 Industrial Computer

Keyboard (continued)

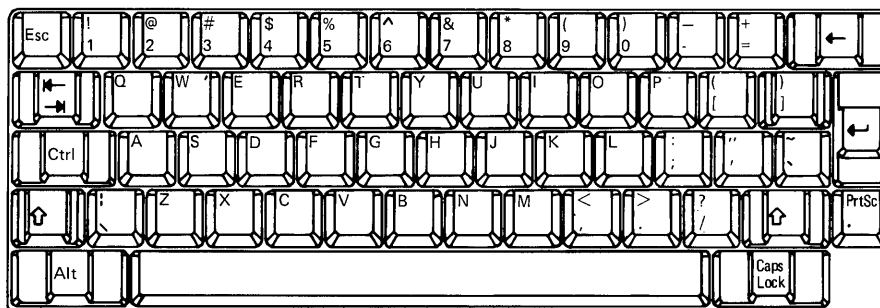

The typewriter keys function as those on a standard typewriter. However, some keys perform special functions. The functions of these keys are described in the following table.

Key	Description
Caps Lock	Caps Lock, when pressed once, locks the characters A through Z in the uppercase position. To shift to lowercase characters while Caps Lock is on, press the Shift key. To return to lowercase, press the Caps Lock key again.
Enter 	The function of the Enter key is defined by the programming language or application you are using. Refer to the appropriate manual for information on the function of the Enter key.
PrtSc*	This key works only if you have a printer. Pressing the PrtSc (Print Screen) key together with the Shift key prints a copy of whatever is displayed on the screen. If the information on the screen consists of alphanumeric characters, as in a program listing, that information is printed. If the information on the screen consists of graphics characters, it can be reproduced only by a printer that supports graphics printing.

Keyboard (continued)

Key	Description
Backspace ←	Backspace moves the cursor one space to the left, erasing the existing character.
Space bar	The Space bar moves the cursor to the right. Any character the cursor moves over is replaced with a blank.
Alt	Alt (Alternate) makes it easy for you to type BASIC statement keywords. When you press Alt together with any alphabetic key (A through Z), the BASIC keyword is entered. You can use Alt with Ctrl (Control) and Del (delete); see "Special Key Combination" at the end of the keyboard section. You can also use Alt together with any of the keys on the numeric keypad to enter ASCII codes. Refer to <i>IBM Personal Computer BASIC</i> for more information on the Alt key.
Ctrl	Ctrl (Control) performs a variety of functions. These functions are described in the manual that came with your operating system or application program. You can use Ctrl together with Alt (Alternate) and Del (Delete); see "Special Key Combination" at the end of the keyboard section.
Esc	Refer to the manual that came with your operating system or application program for information on the function of the Esc (Escape) key.
Tab ← →	Tab moves the cursor to the next tab stop. Refer to the manual that came with your operating system or application program for information on how tab stops are defined.
Shift ↑	The keyboard has two shift keys. Pressing either of these keys changes the alphabetic keys to the uppercase state. Then, when you press the alphabetic keys, the characters appear as capital letters.

Introducing the IBM 5531 Industrial Computer

Keyboard (continued)

Numeric Keypad The illustration shows the keys on the numeric keypad. The table that follows explains the use of each key on the numeric keypad.

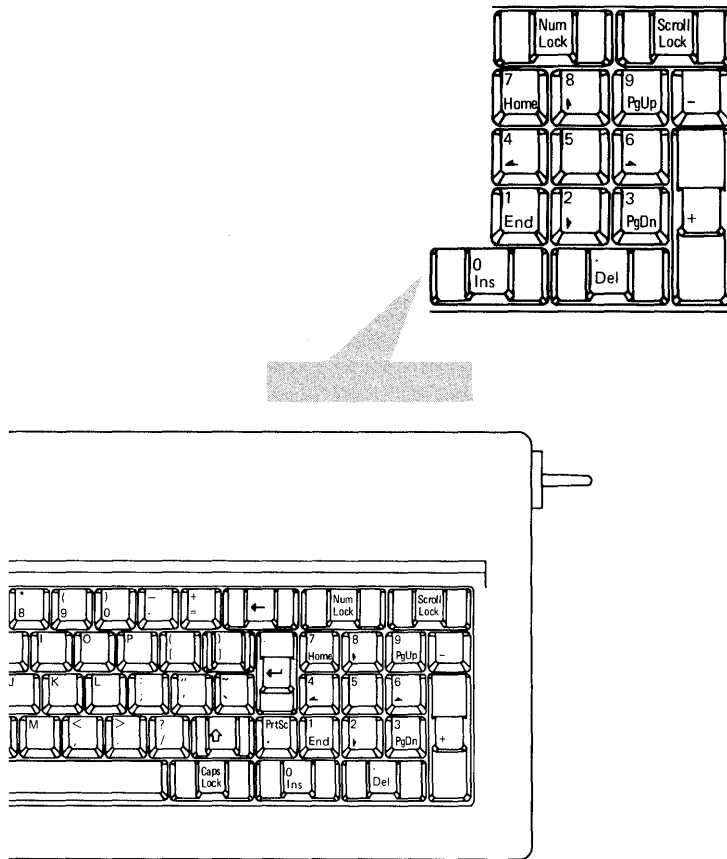

Keyboard *(continued)*

Key	Description
Num Lock	Pressing Num Lock (Numeric Lock) once places keys 0 through 9 of the numeric keypad in the numeric state. Then, when you press any one of these keys (0 through 9), a number appears on the screen. Pressing Num Lock again returns keys 0 through 9 to the cursor-control function.
Scroll Lock	Refer to the manual that came with your operating system or application program for information on the use of Scroll Lock.
Ins	Ins (Insert), when pressed, enables you to add characters in the middle of a line. Pressing Ins again returns the key to normal operation.
↑	Cursor Up moves the cursor to the preceding line.
↓	Cursor Down moves the cursor to the next line.
→	Cursor Right moves the cursor one character position to the right.
←	Cursor Left moves the cursor one character position to the left.
Home	Refer to the manual that came with your operating system or application program for information on the use of the Home key.
End	End moves the cursor one position to the right of the last character on a line.
PgUp	Refer to the manual that came with your operating system or application program for information on the use of the PgUp (Page Up) key.
PgDn	Refer to the manual that came with your operating system or application program for information on the use of the PgDn (Page Down) key.
Plus (+) or Minus (-)	When the Plus or the Minus key is pressed, a plus or a minus sign appears on the screen.
Del	You can use Del (Delete) with Alt (Alternate) and Ctrl (Control); see "Special Key Combination" at the end of the keyboard section. Refer to the manual that came with your operating system or application program for information on the use of the Del (Delete) key.

Introducing the IBM 5531 Industrial Computer

Keyboard (*continued*)

Function Keys

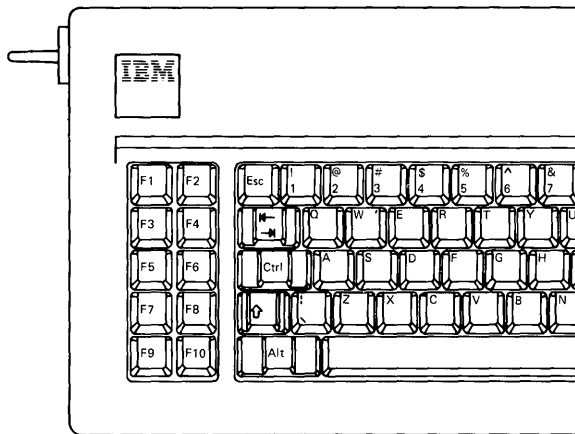

The function keys (F1 through F10) are always under program control. Refer to the manual that came with your operating system or application program for information on the use of the function keys.

Special Key Combination

The Alt (Alternate), Ctrl (Control), and Del (Delete) keys can be pressed simultaneously to perform a *system reset*. All three keys must be pressed at the same time. Doing a system reset with these keys is faster than setting the system unit's Power switch to Off and then to On again when you wish to start over (insert a new program and so on).

Keyboard *(continued)*

Adjusting the Keyboard Tilt Position

The tilt of the keyboard can be adjusted for your typing comfort. To adjust the tilt, hold the keyboard. Firmly push in the adjustable handles, and turn them to the desired position as shown below.

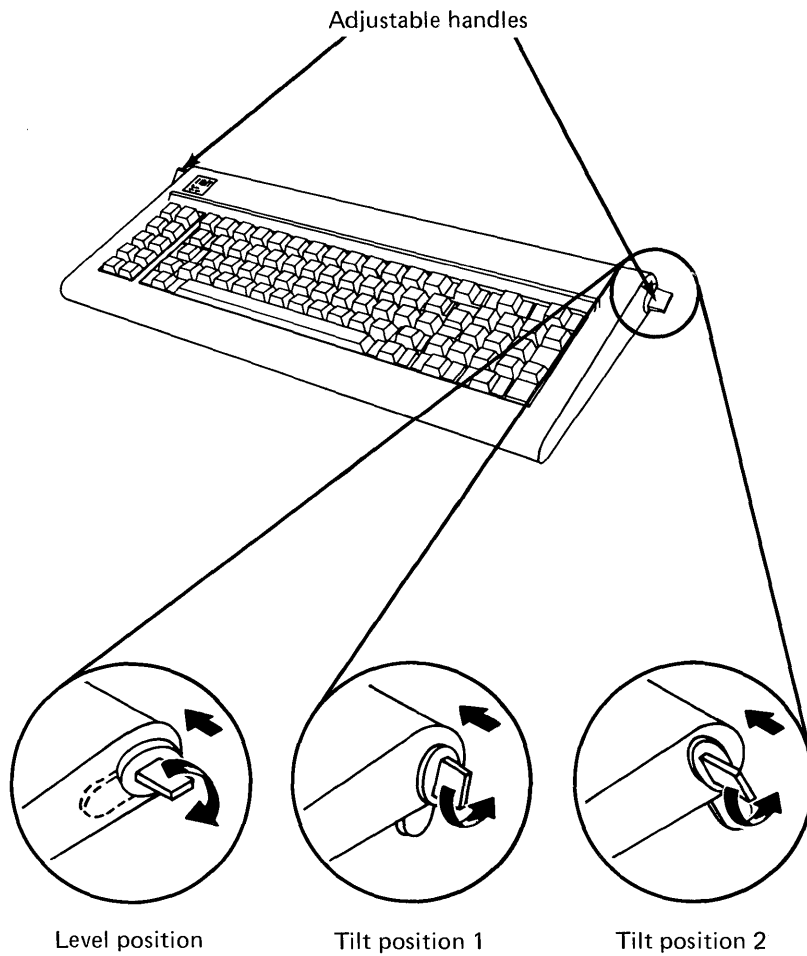

Introducing the IBM 5531 Industrial Computer

IBM Industrial Display

You can attach a display to the system unit. The display may be an IBM Industrial Display or a non-IBM display. The illustrations show a front and a rear view of an IBM Industrial Display and identify the important parts for you.

Warning: Make sure the display you are using, like an IBM Industrial Display, has been specifically designed for an industrial environment; otherwise, you may damage your display.

Front View

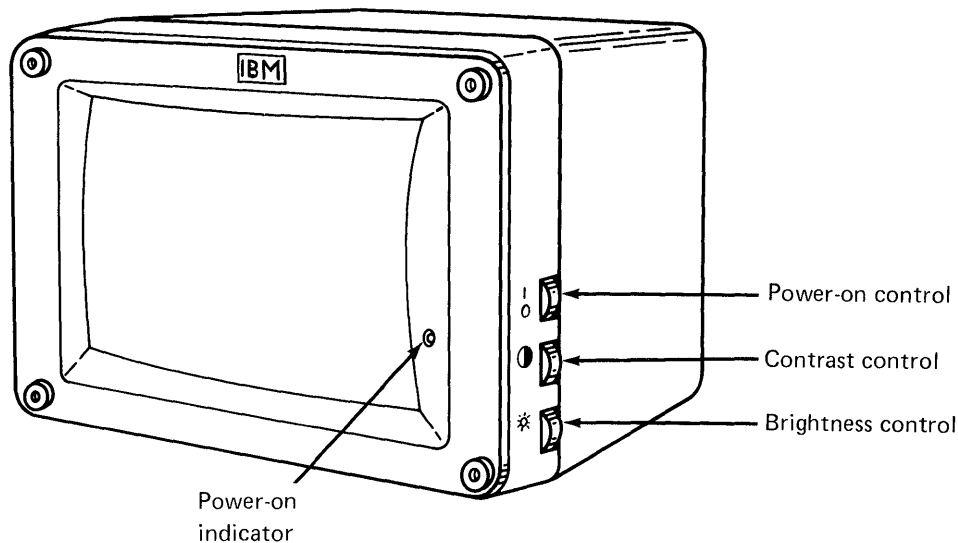

The illustration shows the Power-on control, the Contrast control, the Brightness control, and the Power-on indicator. When switching on power to an IBM Industrial Display, use the Power control. A Power-on indicator light lets you know that power is switched on. The Contrast control is used to increase or decrease the intensity of black, blue, green, cyan, red, magenta, brown, and white. The Brightness control is used to increase or decrease the brightness of the entire screen.

IBM Industrial Display *(continued)*

Rear View

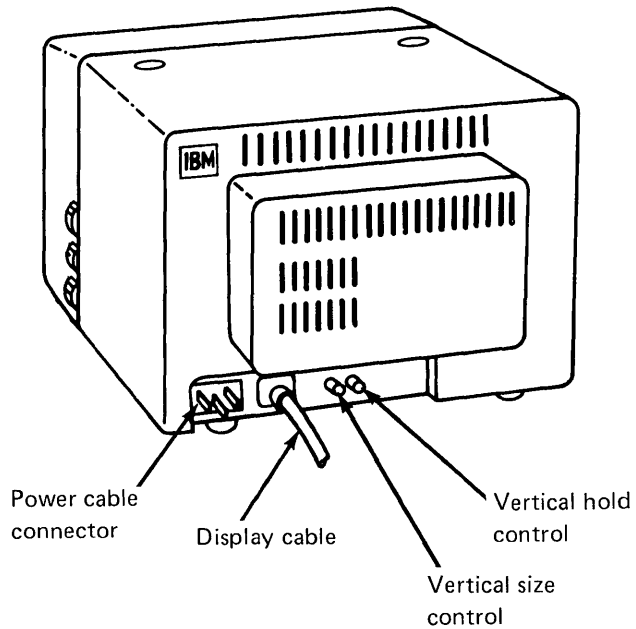

The illustration shows the signal cable that connects the display to the system unit and the power-cord connector for the display. The illustration also shows the vertical-hold control and the vertical size control. Use the vertical hold control only when the screen presentation is rolling from top-to-bottom or from bottom-to-top. Use the vertical size control only when the character size is incorrect.

Introducing the IBM 5531 Industrial Computer

Options or Adapters for the IBM 5531 Industrial Computer

Some options or adapters that may be installed in the IBM 5531 Industrial Computer are:

- 64/256KB Memory Expansion option
- Monochrome Display and Printer Adapter
- 3278/3279 Emulation Adapter
- IBM Personal Computer Cluster Adapter
- Binary Synchronous Communications (BSC) Adapter
- SDLC Adapter
- Color/Graphics Monitor Adapter
- Graphics Memory Expansion
- General Purpose Interface Bus (GPIB) Adapter
- Data Acquisition and Control Adapter
- Enhanced Graphics Adapter
- 10Mb Fixed Disk Drive Kit
- PC Network Adapter
- Asynchronous Communications Adapter

Other options include the keylock for the drive cover door on the system unit, and the Combination Adapter cable for use with the Combination Adapter card installed in the system unit.

For information about these and other options, contact your place of purchase.

Summary

Chapter 1 explained the components of the IBM 5531 Industrial Computer. The chapter showed you the hardware contained in a typical system. The illustrations identified the important parts of each system component. Chapter 1 also described the functions of the keys on the 5531 keyboard.

Chapter 2. Cabling the IBM 5531 Industrial Computer

This chapter provides step-by-step instructions for connecting the cables to the system unit and running the power-on self-test (POST).

This chapter shows you how to:

- Connect the cables to the system unit
- Run the power-on self-test (POST).

You should follow the steps in the order they are given.

Cabling the IBM 5531 Industrial Computer

Connecting the Cables

To connect the cables:

1. Place the keyboard next to the system unit, and connect the keyboard cable as shown.

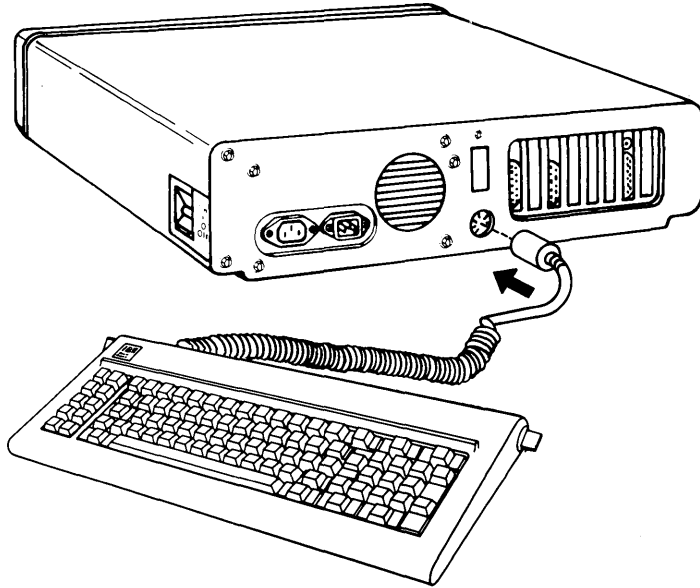

2. Place the keyboard in front of the system unit. Make sure the keyboard cable is as shown.

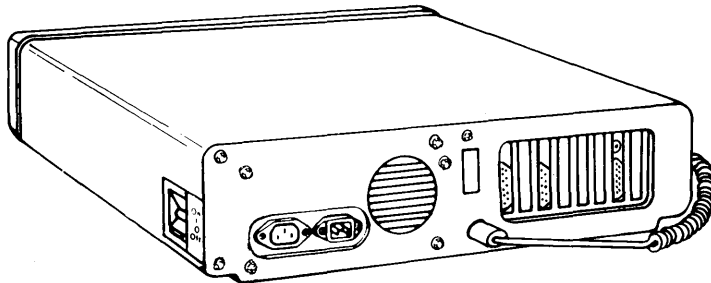

Connecting the Cables *(continued)*

3. Make sure that the Power switch is set to Off.

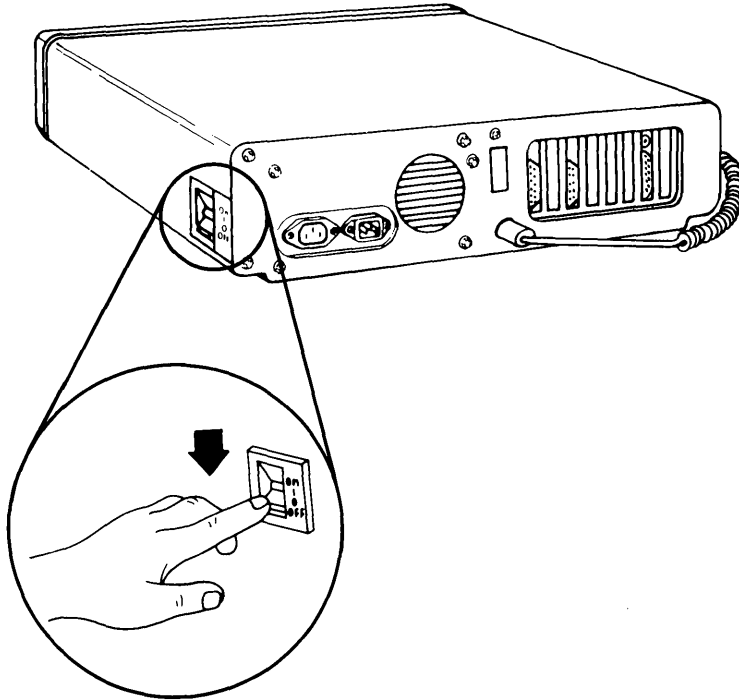

| is the international symbol for On.

○ is the international symbol for Off.

Cabling the IBM 5531 Industrial Computer

Connecting the Cables *(continued)*

4. Connect the system unit's power cord to the back of the system unit.

CAUTION

This product is equipped with a line cord and plug designed for your safety. They are to be used with a properly grounded power receptacle to avoid possible electrical shock.

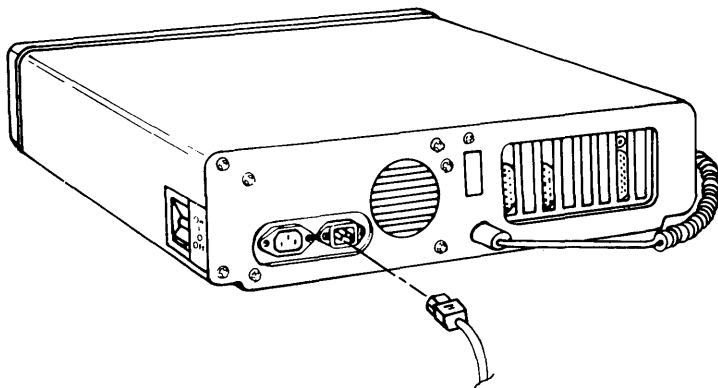

5. Place the display at convenient location or within cable distance from the system unit.
6. Connect the display's power cord to the back of the display.

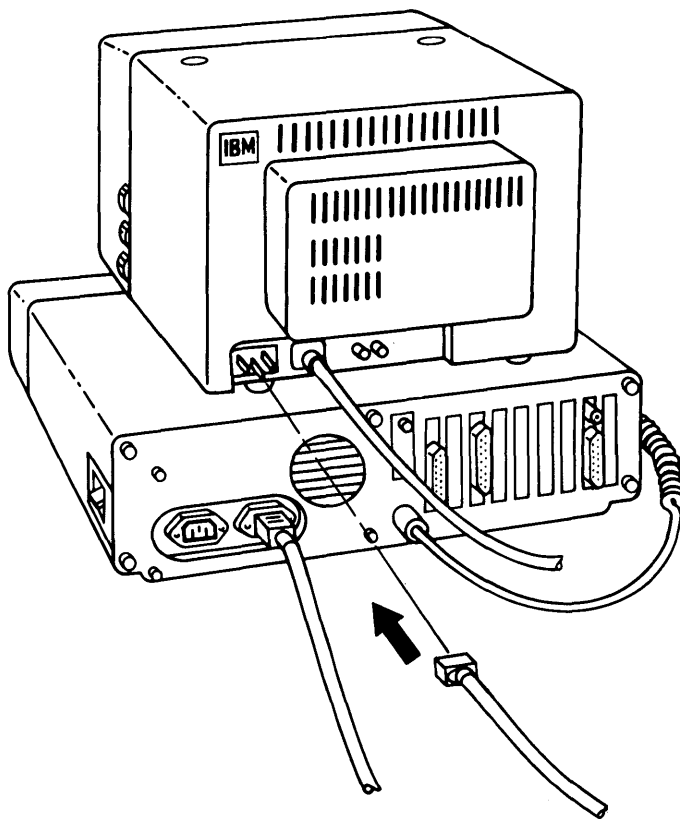

Connecting the Cables (continued)

7. Connect the display's signal cable to the system unit as shown below. Use a flat-blade screwdriver to tighten the screws.

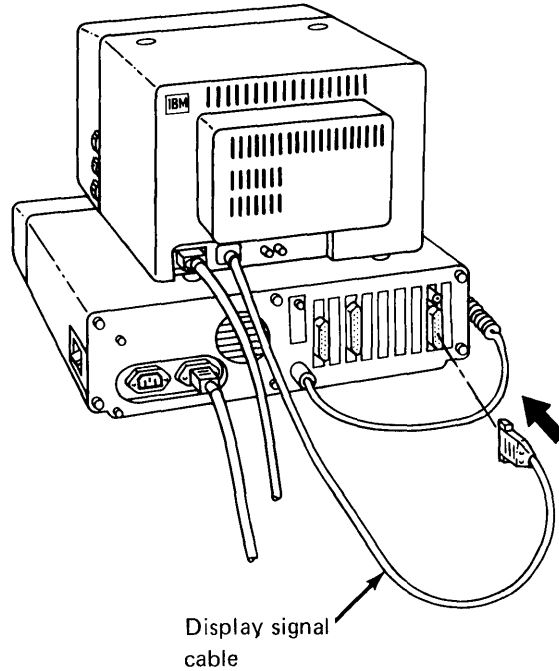

Before you plug the power cords in to the power outlets, you need to install cable-retaining brackets on both the display and the system unit.

8. Loosen the two screws on the system unit as shown below.

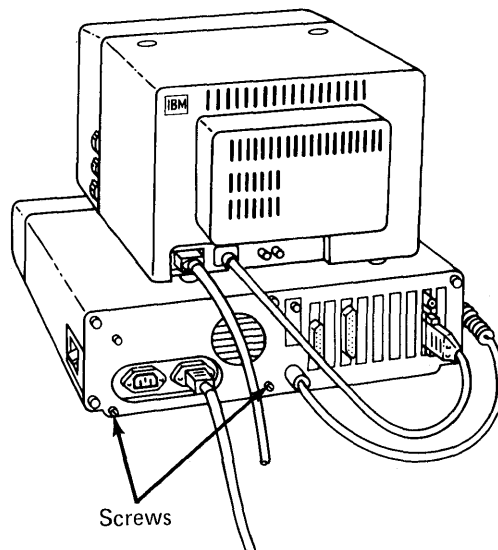

Cabling the IBM 5531 Industrial Computer

Connecting the Cables (*continued*)

9. Place the cable-retaining bracket over the cables on the system unit. Make sure that the screws are aligned in the two slots in the bracket. Also, make sure that the bracket fits securely over the cables. When the bracket is secure, tighten the screws.

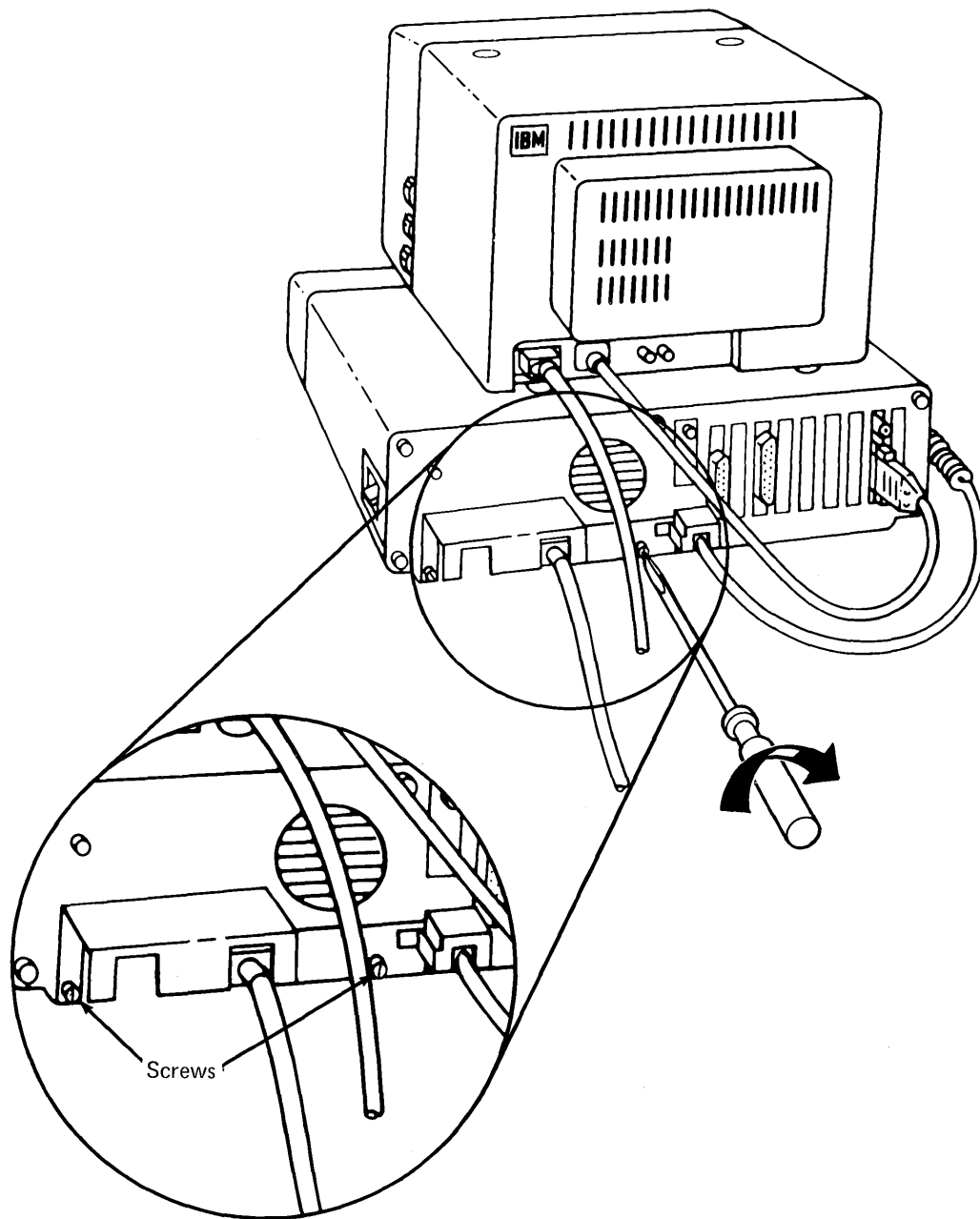

Connecting the Cables *(continued)*

10. Place the cable-retaining bracket under the power cord on the display and tighten the screws as shown.

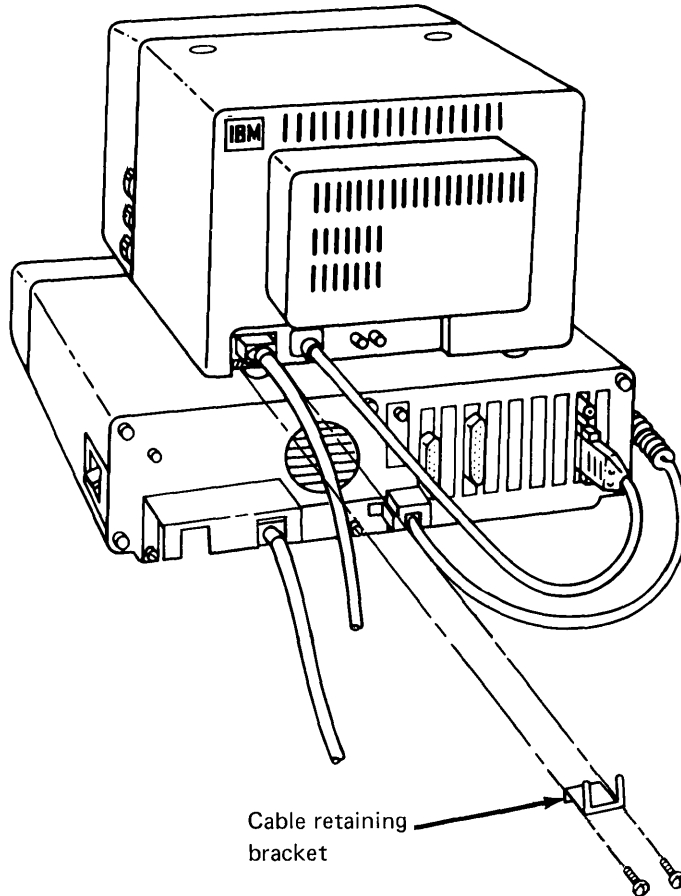

11. Plug the power cords from the system unit and the display in the power outlet.

Cabling the IBM 5531 Industrial Computer

Running the Power-On Self-Test (POST)

The power-on self-test runs every time you set system power on and tests the base system and memory. The POST takes between 13 and 90 seconds to run, depending on the amount of memory installed in the system unit. As the POST is running, the amount of memory already tested is displayed on the screen. The number increases until it is equal to the amount of memory installed. If the POST has finished successfully, you will hear one short beep.

1. Adjust the controls on the display for maximum brightness and contrast.
2. Switch on the power to all attached devices (display, printer, and so on).
3. Set the system unit's Power switch to On.

As the POST is running, a series of messages similar to the following example should be displayed on the screen:

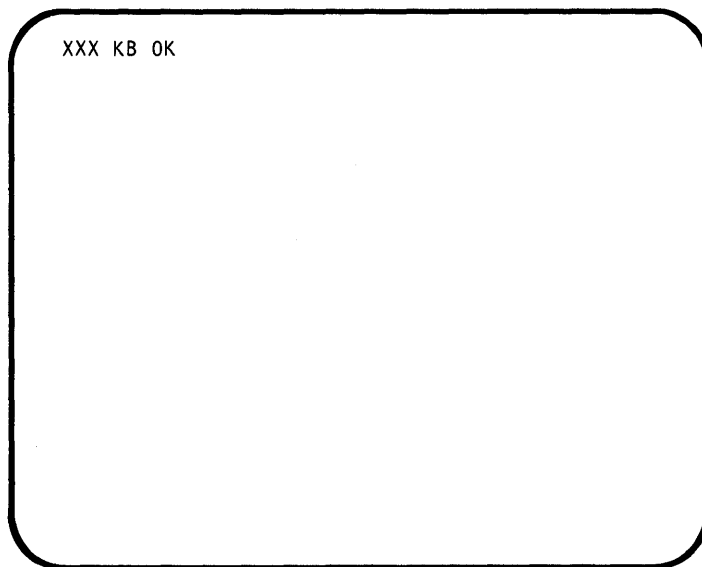

Note: If your screen does not look similar to the example, or if nothing appears on the screen, refer to Chapter 5, "Problem Determination Procedures."

Running the Power-On Self Test (POST) *(continued)*

As we mentioned before, when the POST has finished successfully, you will hear one short beep.

Then, the following screen should appear:

```
The IBM Personal Computer Basic
Version X.XX Copyright IBM Corp. 1981
XXXX Bytes Free
Ok

1LIST 2RUN 3LOAD"4SAVE"5CONT 6LPT1 7TRON 8TROFF 9KEY 0SCREEN
```

If you heard one short beep and your screen looks like the example above, then the system completed its power-on self-test successfully. You are now ready to begin using the 5531 Industrial Computer.

If you did not hear a beep, if nothing appeared on the screen, or if the screen is not centered properly, refer to Chapter 5, "Problem Determination Procedures."

Note: If a program from a diskette or an operating system from the fixed disk drive is automatically loaded, the first screen that appears will look different from our example. If the displayed screen is correct, you are now ready to begin using the 5531 Industrial Computer.

Cabling the IBM 5531 Industrial Computer

Running the Power-On Self-Test (POST) *(continued)*

Summary

You have connected all the cables. You have run the power-on self-test to make sure the system unit is working correctly.

Chapter 3. Diskettes and Utilities

This chapter provides information on handling diskettes, write-protecting a diskette, inserting a diskette in the diskette drive, and removing a diskette from the diskette drive.

Diskettes and Utilities

Handling Diskettes

Before you insert a diskette in the drive, you should be aware of the proper way to handle diskettes. The following illustrations show how to handle diskettes.

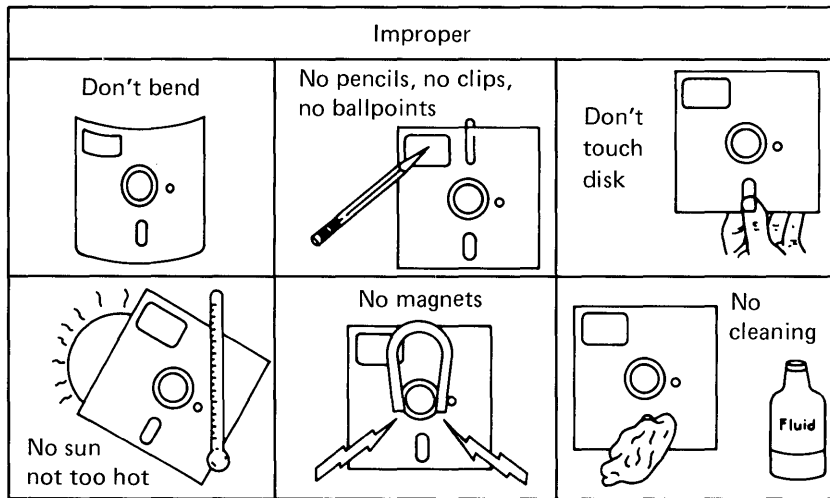
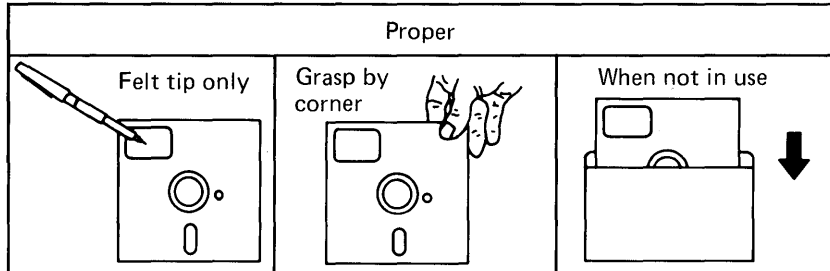

Write-Protecting a Diskette

When a diskette is write-protected, no information can be stored (written) on the diskette.

To write-protect a diskette, cover the notch on the side of the diskette with a write-protect tab.

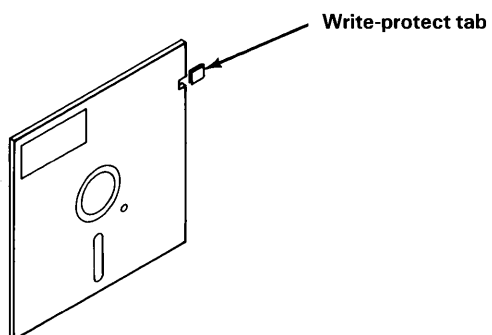

If you want to store (write) information on a diskette that is write-protected, you must remove the write-protect tab.

Diskettes and Utilities

Inserting and Removing a Diskette from the Drive

Inserting a Diskette in the Diskette Drive

To insert a diskette in the diskette drive:

1. Open the drive cover door.

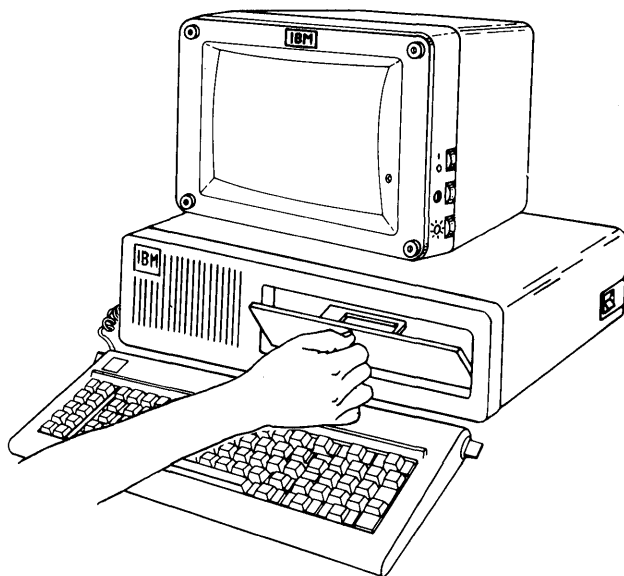

2. Open the drive load lever.

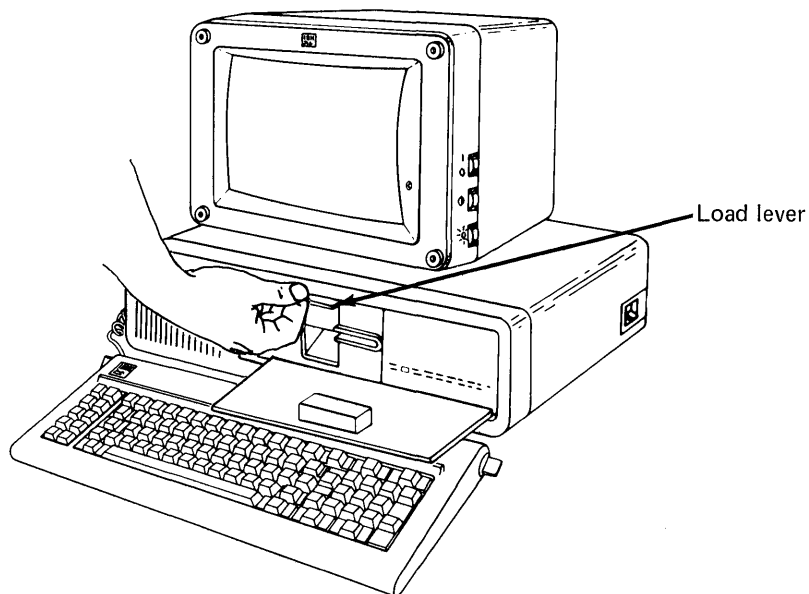

Inserting and Removing a Diskette from the Drive *(continued)*

3. Insert the diskette in the diskette drive as shown.

Note: Make sure that the diskette label faces up and is in the position shown below.

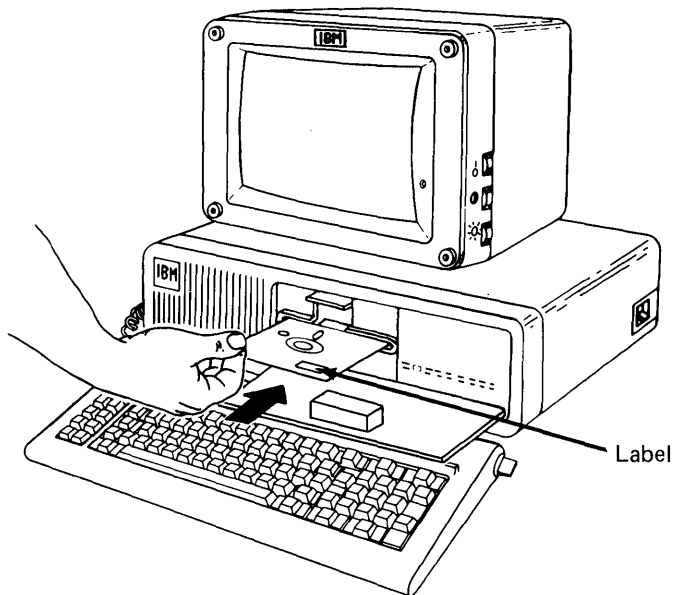

4. Close the drive load lever.
5. Press the Alt, Ctrl, and Del keys together to load the program.

In a moment, the in-use light will blink. The light lets you know that the system is using the diskette drive.

Warning: *Do not* open the drive load lever when the in-use light is on. Your diskette data may be damaged if you do.

Removing a Diskette from the Diskette Drive

To remove a diskette from the diskette drive:

1. Open the drive cover door.
2. Make sure that the in-use light is off.

Warning: *Do not* open the drive load lever when the in-use light is on. Your diskette data may be damaged if you do.

3. Open the drive load lever and remove the diskette.

Diskettes and Utilities

IBM Industrial Computer Utilities

If your IBM Industrial Computer does not have the realtime clock and thermal utilities installed, refer to the *IBM 5531 Industrial Computer Installation and Setup Manual*.

Thermal Warning

To activate the Thermal Warning program, when the DOS prompt appears, type **THERMAL** and press the **Enter** key. The Thermal Warning program is now loaded in DOS.

While using DOS, if the internal operating temperature of the IBM 5531 Industrial Computer exceeds its design limits, the message THERMAL WARNING will be posted on line 25 of the display. The message will also contain the time the thermal warning was detected. The system will continue to run with this message displayed and the system beeper sounding at 10-second intervals for 10 minutes.

Warning: If you do not respond to this warning, the program you have been using automatically stops. However, the system unit continues to run.

If the temperature returns to normal before the 10 minutes is up, the timer and beeper reset and the message THERMAL NORMAL is displayed. If after 10 minutes the temperature has not returned to normal, and the program has stopped, switch off the system unit's power, and allow the system unit to cool. Check the filter in the system unit. Refer to Chapter 4, "Checking and Replacing Filters." Then you can restart the system and begin work again. If you still have problems, contact your service representative.

Summary

In this chapter, you learned how to handle diskettes and how to insert a diskette in the diskette drive. You learned how some of the keys work on the 5531. In general, you have become familiar with the 5531. You also learned how to handle a thermal warning.

Chapter 4. Checking and Replacing Filters

This chapter describes how to check and replace the filters in the IBM 5531 Industrial Computer and an IBM Industrial Color Display. You will need to check them at least once a week or as often as necessary depending on your environmental conditions. The filters protect the system unit and display from any particles that would otherwise enter and damage them.

Refer to this chapter when you need to check or replace the filters.

Checking and Replacing Filters

System Unit Filter

Checking and Replacing the System Unit Filter

The filter is located on the front left side of the system unit.

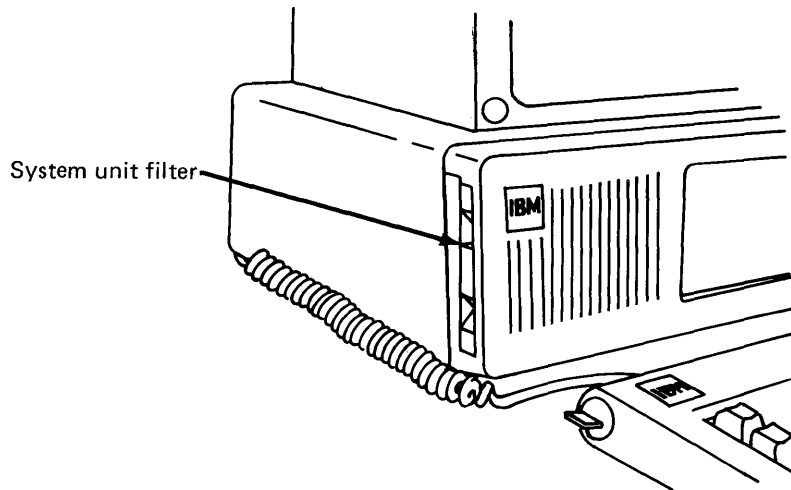

To check or replace the filter:

1. Make sure the system unit's Power switch is set to Off.
2. Slide the filter frame out of the system unit.

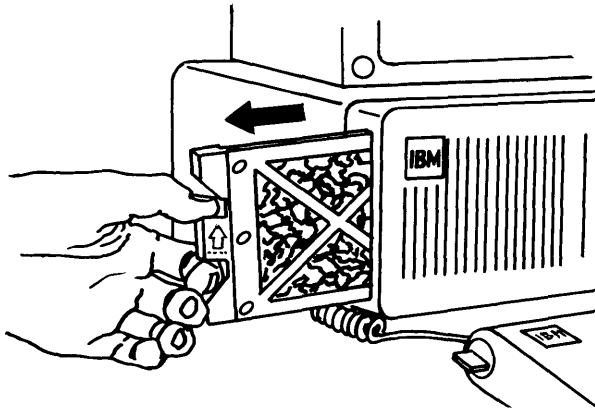

System Unit Filter *(continued)*

3. Check the filter. If necessary, remove the filter from the frame, and replace it with a new one.

If you need new filters, contact your place of purchase.

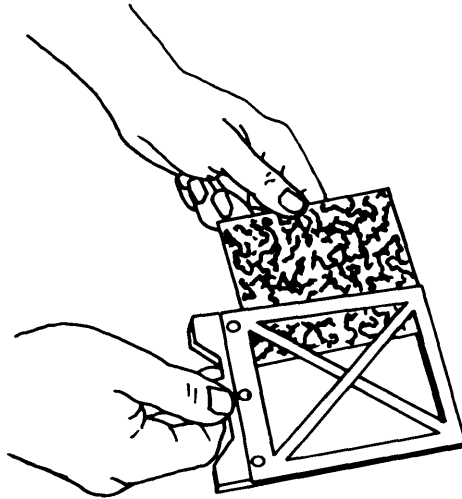

Before you slide the frame back into the system unit, notice that there are arrows on the side of the frame. The arrows indicate the top of the frame. When you replace the filter, make sure the arrows are pointing up.

Warning: The filter frame must be inserted completely for proper operation. **DO NOT FORCE** the filter frame into the system unit! Remove it and try again. Make sure the arrows on the side of the filter frame are pointing up.

4. Slide the filter frame into the system unit.

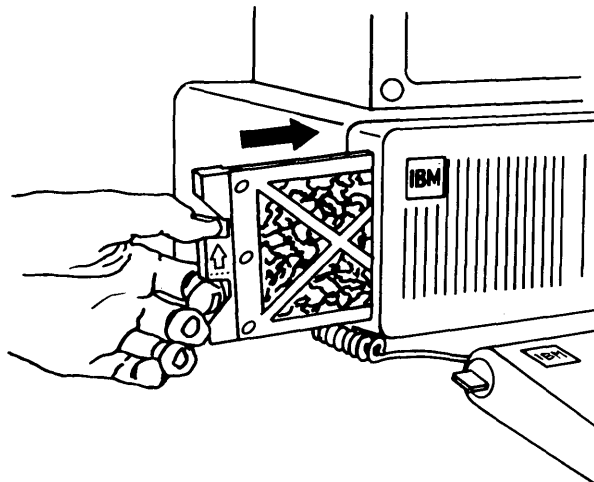

Checking and Replacing Filters

IBM Industrial Color Display Filter

Checking and Replacing an IBM Industrial Color Display Filter

You need a flat-blade screwdriver for this procedure. The display filter is located on the bottom of the display.

To check or replace the display filter:

1. Set the system unit's Power switch to Off.
2. Set the display's Power control to Off.
3. Unplug the system unit and display from the power outlet.
4. Place the display off to the side of the system unit.

Note: You may need to disconnect the display from the system unit to set the display off to the side. If so, do it before you move the display. You may damage the cord if you do not disconnect it.

5. Turn the display on its side as shown below. Make sure that you do not set it on the side with the controls.

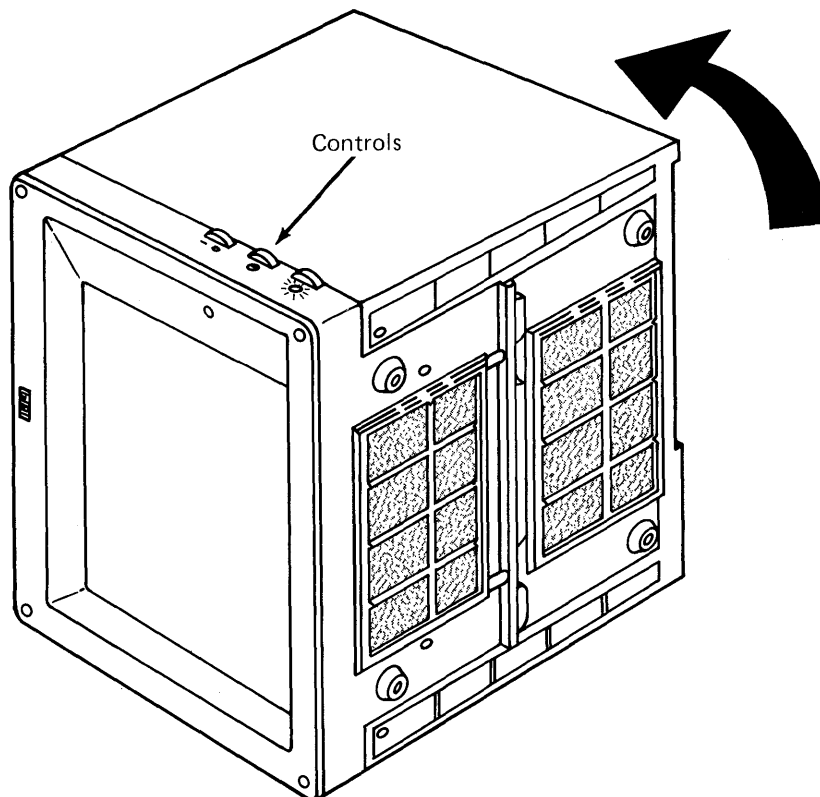

IBM Industrial Color Display Filter *(continued)*

6. Locate the eight cover snaps. Place a flat-blade screwdriver under the cover by the snaps and pop them open as shown.

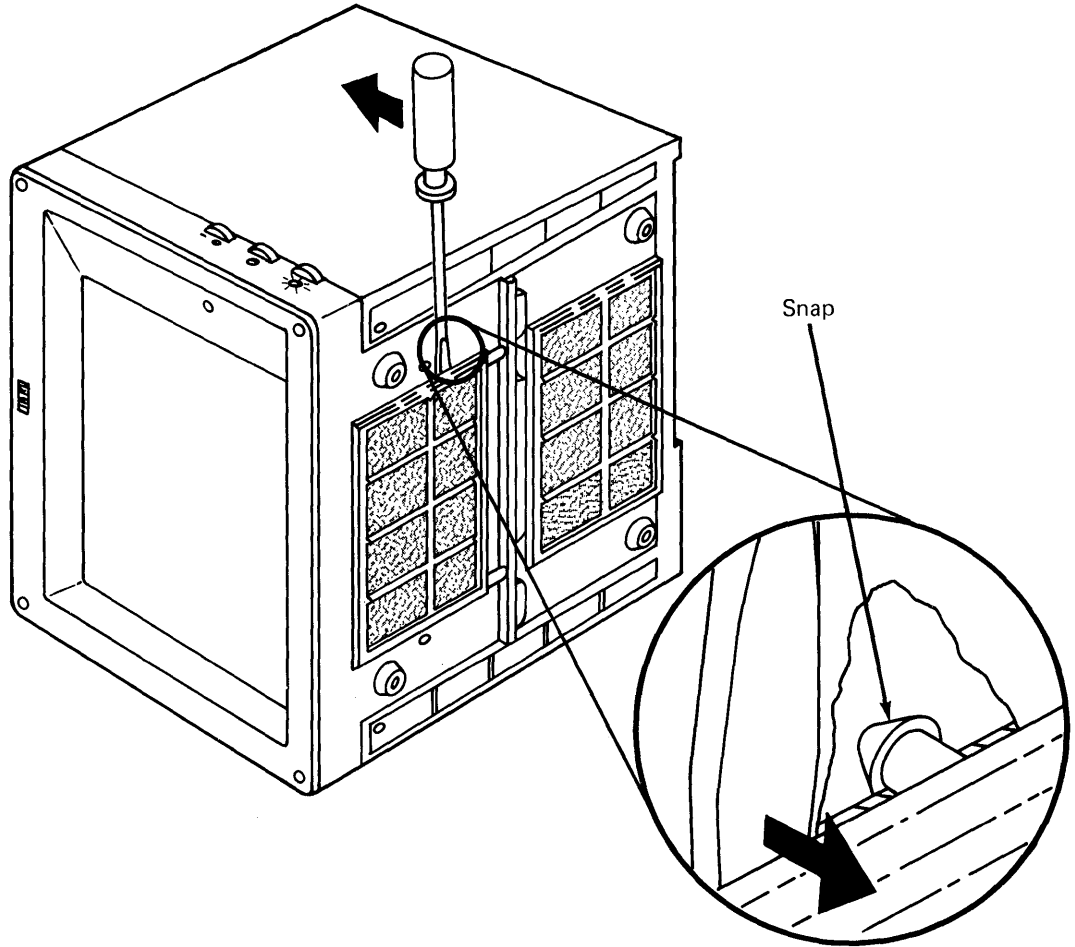

Checking and Replacing Filters

IBM Industrial Color Display Filter *(continued)*

7. Remove the bottom covers and check the filters. Replace the filters if necessary.

If you need new filters, see your place of purchase.

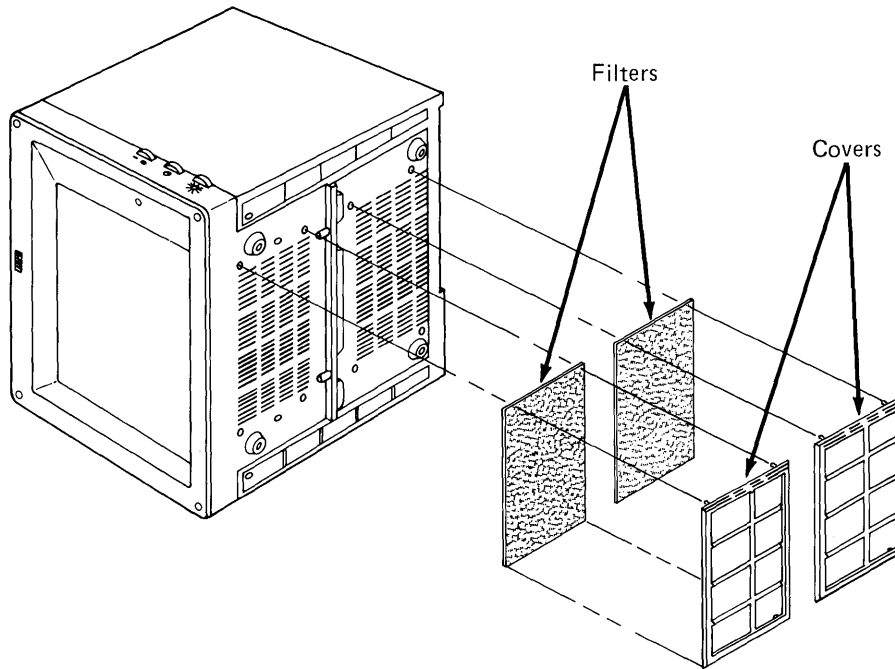

8. Replace the bottom covers. Push the cover snaps back into place.
9. Return the display to its normal operating location. Reconnect all cables (refer to Chapter 2, "Cabling the IBM 5531 Industrial Computer," if you need help.)

Chapter 5. Problem Determination Procedures

If you experience a problem with your IBM 5531 Industrial Computer or an IBM Industrial Color Display, the problem determination procedures will help you find which unit in your system is failing. The procedures can also be used to check that your system is operating correctly. Follow the step-by-step instructions and answer yes or no to the questions asked.

As part of the problem determination, use the *Diagnostics* diskette, which is at the back of this manual. The diskette contains a series of tests that check the units of your system: the system unit, keyboard, and display. The tests are performed in sequence. Follow the steps and instructions that appear on the screen and use this chapter for screen reference.

The chapter contains the following sections:

- Checking Electrical Connections
- Checking the IBM Cluster Adapter
- Running the Power-On Self-Test
- Formatting a Diskette
- Diagnostic Test Error Messages
- Loading Diagnostics
- System-Test Reference Screens
- Adjusting Screen Alignment.

Problem Determination Procedures

Checking Electrical Connections

If all of your system components power-on successfully, go to “Checking the IBM Cluster Adapter” in this chapter.

If all or any one of your system components does not power on when you set the Power switch to On, you should check for an electrical problem.

1. Set the system unit’s Power switch to Off.
2. Set the display’s Power switch to Off.
3. Unplug the system unit and display from the power outlets.
4. Check the power outlets by plugging in a lamp (or some other device) that works.
5. Does the power outlet(s) work?
 - YES** – Continue with Step 6.
 - NO** – Repair the outlet(s) or plug the system into a working outlet(s). Switch the system power on. If the problem still exists, continue with Step 6. If the problem no longer exists, go to “Checking the IBM Cluster Adapter” in this chapter.
6. Make sure the system unit’s and display’s Power is set to Off.
7. Remove the cable-retaining brackets from the system unit and the display. Disconnect all attached devices.
8. Connect each cable to the proper connector on the system unit and the display. Replace the cable-retaining brackets.
9. Plug the power cords for the system unit and the display in the power outlets.
10. Set the system unit’s and display’s Power switch to On.
11. Does the system power on?
 - YES** – You have completed this section successfully.
 - NO** – Set the system unit’s and display’s Power switches to Off. Go to “Loading Diagnostics” in this chapter.

Checking the IBM Cluster Adapter

Note: If you do not have an IBM Cluster Adapter, continue with the next section.

The IBM Cluster Adapter is sold with a terminating plug. This procedure requires that you use that plug.

1. Disconnect the coaxial cable from the Cluster Adapter's connector.
2. Install the terminating plug (IBM part number 6320352) on the Cluster Adapter's connector as shown below.

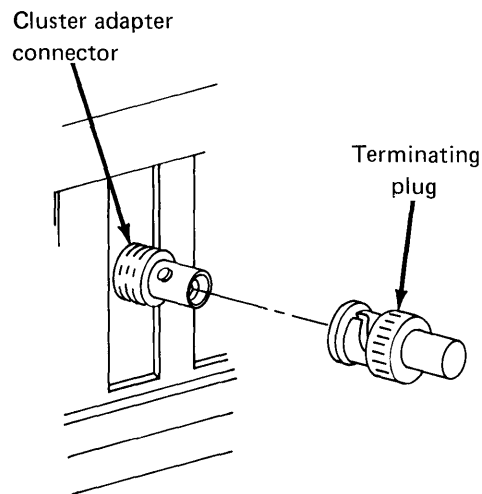

You have completed connecting the cluster adapter terminating plug. Continue with the next section.

Problem Determination Procedures

Running the Power-On Self-Test (POST)

The power-on self-test runs every time you set system power on and tests the base system and memory. The POST takes between 13 and 90 seconds to run, depending on the amount of memory installed in the system unit. As the POST runs, the amount of memory tested is displayed on the screen. The number increases until it is equal to the amount of memory installed. If the POST has finished successfully, you will hear one short beep.

1. Set the controls on your display for maximum brightness and contrast. Refer to the manual that came with your display if necessary.
2. Set the display's Power control to On.

Note: If you have a PC Network Adapter installed, a translator unit must be plugged in and powered On to successfully complete the POST.

3. Set the system unit's Power switch to On.

As the POST is running, something similar to the following example should be displayed in the upper-left corner of the screen:

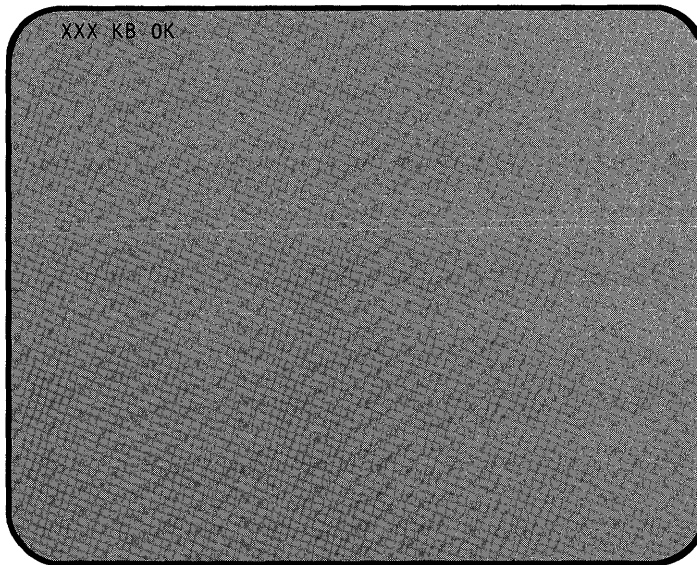

Running the Power-On Self-Test (POST) *(continued)*

As we mentioned before, when the POST has finished, you will hear one short beep.

Then, the following screen should appear:

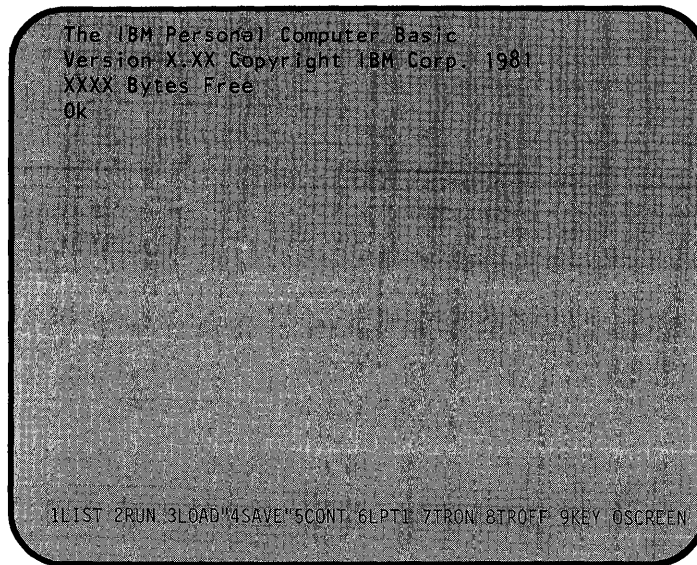

If you heard one short beep and your screen looks like the example above, then the system completed its power-on self-test successfully. Go to the section, “Formatting a Diskette,” in this chapter.

Note: If a program from a diskette or an operating system from the fixed disk drive is automatically loaded, the first screen that appears will look different from our example. If this screen is correct (for the operating system you are using), you are ready to format a diskette and begin running the diagnostic tests.

If nothing appears on the screen, you did not hear a beep, an error message appears, or if the screen is not centered properly, continue with the next section, “Industrial Computer POST Errors.”

Problem Determination Procedures

Industrial Computer POST Errors

In the following examples, find your screen response and audio response. Then follow the instructions in the box labeled "Action."

Warning: If the instructions tell you to have a unit serviced, and that unit has a fixed disk drive, we recommend that you back up all disk files onto diskettes. Normal shipping and handling can result in permanent loss of data from your fixed disk drives. Refer to the *IBM DOS* manual for a description of the **BACKUP** command.

Screen Response	Audio Response	Action
Amount of memory shown on screen is wrong or cursor is missing	1 short beep	Have the system unit serviced
XX301 XXXKB ERROR (RESUME="F1" KEY)	2 short beeps	Have the keyboard serviced (see Note 1 on the next page)
301 XXXKB OK ERROR, (Resume = "F1" key)	2 short beeps	Have the keyboard serviced (see Note 1 on the next page)
Any error followed by ERROR. (RESUME="F1" KEY)	2 short beeps	Go to "Diagnostic Test Error Messages"
Blank screen or may display anything	Any response other than 1 short beep or continuous beep	See Note 2 on the next page
Screen has wrong or no color	1 short beep	See Note 2 on the next page
Blank Screen or obvious TV-type problems (such as rolling screen or shadows)	1 short beep	See Note 2 on the next page
Blank screen	No response	Have the system unit serviced
Error message indicating disk or diskette loading problem	1 short beep	Go to "Loading Diagnostics"
Blank screen or may display anything	Continuous beep	See Note 3 on the next page

Industrial Computer POST Errors *(continued)*

Notes:

1. Make sure that the keyboard is connected correctly, and check for any objects or foreign material on the keyboard. If error 301 still appears after the keyboard has been serviced, have the system unit serviced.
2. If you are using a non-IBM display, verify that the color is correct by disconnecting your display from the system unit and operating it normally. If you have an IBM Industrial Color Display, go to “Test 9000 - IBM Industrial Color Display” in this chapter.
3. Do the following:
 - a. Set the system unit’s Power switch to Off.
 - b. Disconnect the keyboard.
 - c. Set the system unit’s Power switch to On.
 - d. **DID THE FAILING SYMPTOM REMAIN?**

YES – Have the system unit serviced.

NO – Have the keyboard serviced.

Problem Determination Procedures

Formatting a Diskette

During the diagnostic tests that follow, you will need a *scratch* diskette. (A *scratch* diskette is a formatted diskette with no data on it.) If you already have a scratch diskette, skip this section, and proceed to “Diagnostic Test Error Messages” in this chapter. If you do not have a scratch diskette, continue with this procedure.

1. Remove the *Diagnostics* diskette from the back of this manual.
2. Set the system unit’s Power switch to Off.
3. Open the drive cover door.
4. Lift the drive load lever, remove any diskette that is in the drive, and insert the *Diagnostics* diskette.
5. Close the drive load lever.
6. Set the system unit’s Power switch to On.
7. Did an error message appear on the screen?

Note: Refer to “Diagnostic Test Error Messages” on page 5-13 for a description of the error messages that may appear on the screen.

YES – Press the F1 key, and proceed with Step 8.

NO – Proceed with Step 8.

Formatting a Diskette (*continued*)

8. Did the following appear on your screen?

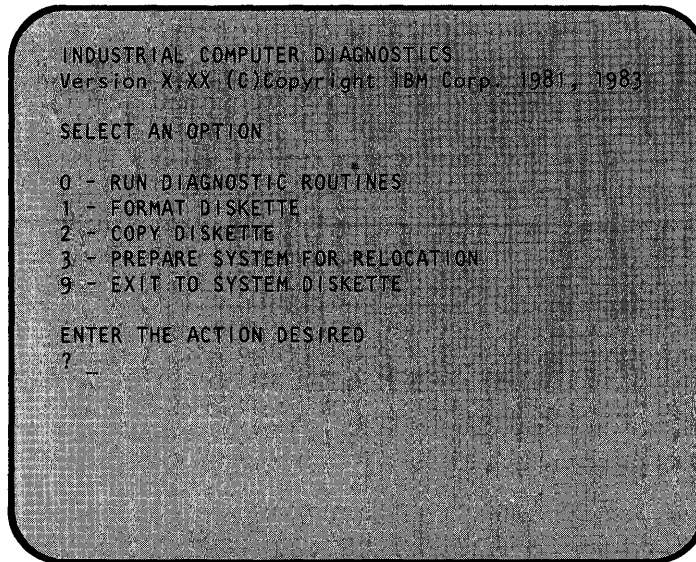

YES – Proceed with Step 9.

NO – Remove the diskette and verify that it is the *Diagnostics* diskette and that it was inserted correctly.

If the *Diagnostics* diskette was inserted correctly, have the system unit serviced.

Note: If you are using a non-IBM display, you could experience data errors when you operate your diskette drive. To correct this problem, move the display a minimum of 30 cm (12 in.) away from the system unit.

9. Press **1** (FORMAT DISKETTE); then press the **Enter** key. If you are unable to enter the proper information have your keyboard serviced; otherwise, proceed with Step 10.

Problem Determination Procedures

Formatting a Diskette (*continued*)

10. Did the following appear on your screen?

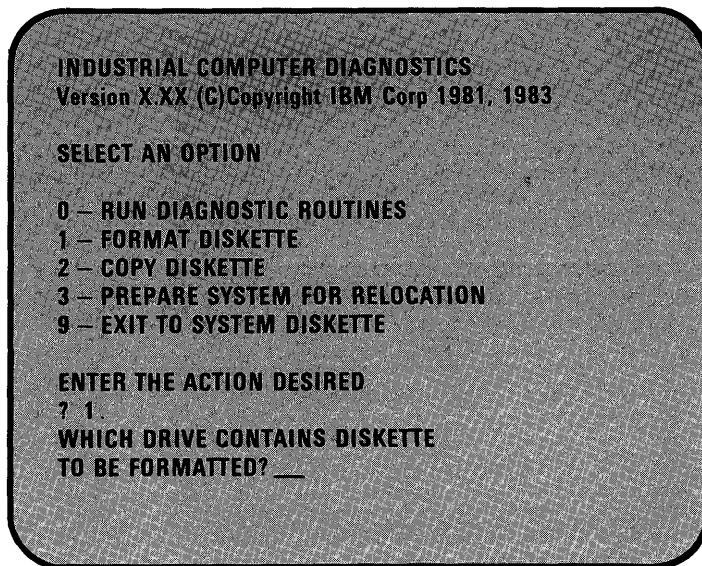

YES – Press **A**; then press the **Enter** key. Proceed with Step 11.

NO – Have the system unit serviced.

Formatting a Diskette (*continued*)

11. Did the following appear on your screen?

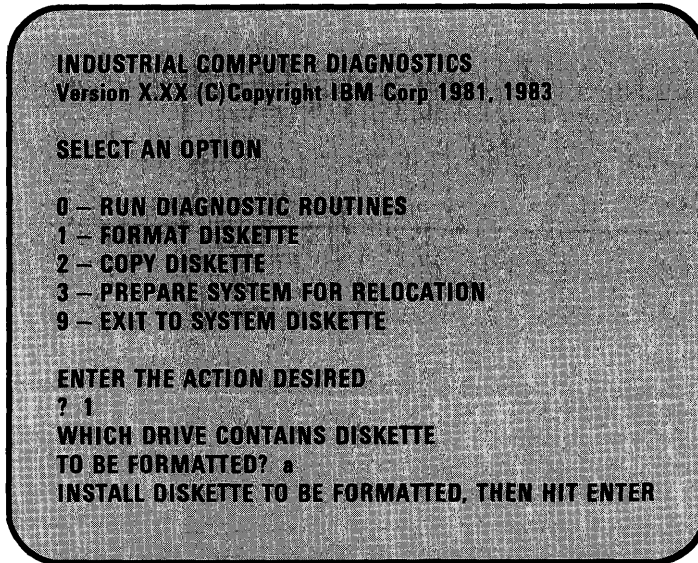

YES – Remove the *Diagnostics* diskette from the diskette drive. Insert a blank diskette, and close the drive load lever. Press the **Enter** key.

The blank diskette will be formatted. When the in-use light goes out, remove the scratch diskette, and replace the *Diagnostics* diskette. Then proceed with Step 12.

NO – Have the system unit serviced.

Problem Determination Procedures

Formatting a Diskette (*continued*)

12. Did the following appear on your screen after the diskette was formatted?

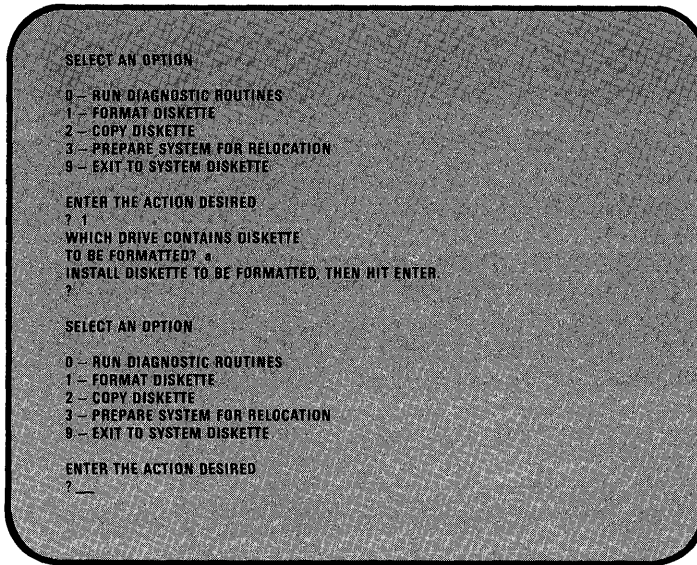

YES – Remove the diskette, insert the *Diagnostics* diskette, and continue with “Diagnostic Test Error Messages.”

NO – Return to Step 2 and try another blank diskette. Be sure to insert the diskette correctly. If the problem still exists, have the system unit serviced.

Diagnostic Test Error Messages

During the diagnostic tests, you may be asked to record an error message. This information is needed when you have your system serviced.

Following are examples of error messages you may receive. A message ending in **00** means the test finished successfully.

In the examples, X can be any alphanumeric character.

Example 1

```
XX:XX:XX  
ERROR - SYSTEM UNIT XXXX
```

Example 2

```
XX:XX:XX  
XXX KB OK  
ERROR.(RESUME = "F1" KEY)
```

Example 3

```
XXX KB OK  
XXXX  
ERROR.(RESUME = "F1" KEY)
```

Example 4

```
XXXX  
XXX KB OK  
ERROR.(RESUME = "F1" KEY)
```

Warning: If Examples 2, 3, or 4 appear on your screen, it means that the POST detected an error. Pressing the F1 key allows the system to bypass the error condition for the diagnostic tests, but your system may not function correctly unless it is serviced.

Continue with "System Testing Information."

Problem Determination Procedures

System Testing Information

Note: Tests are run only on the installed options in your IBM 5531 Industrial Computer.

Before a test runs, the test number is displayed on the screen along with instructions. Follow the instructions as they appear. If you receive an error message during any of the tests, record the error message and have the system unit serviced, unless otherwise stated.

The minimum configuration required to perform customer diagnostics is:

- System unit with 128Kb memory
- One diskette drive
- Display adapter
- Display

Some of the tests ask you **IS THIS SCREEN CORRECT?** Turn to the reference screen under the corresponding test number in this manual to compare the screens.

If the screen is correct, press **Y** and then the **Enter** key to continue to the next screen or test.

If the screen is incorrect, press **N** and then the **Enter** key. Record any error message that appears and have the system unit serviced, unless otherwise stated.

System Testing Information *(continued)*

Have your system unit serviced if you get any of the following errors. Be sure your keylock key (if you have one) is with your system unit.

- A parity check error
- A ROM error
- A screen with a blinking cursor and you are unable to continue
- The same screen indefinitely and you are unable to continue.

You are now ready to begin the diagnostics tests. If you have not formatted a diskette for each installed diskette drive, go to “Formatting a Diskette” earlier in this section before beginning the tests.

Remember: During the tests, you may be asked to record an error. This information is needed to assist you in getting your system unit serviced.

Continue with “Loading Diagnostics” in this chapter.

Problem Determination Procedures

Loading Diagnostics

If you came here from “Formatting a Diskette,” go to Step 11. Otherwise begin with Step 1.

1. Remove the *Diagnostics* diskette from the back of this manual.
2. Set the system unit’s Power switch to Off.
3. Set the power switches on all attached devices to Off.
4. Open the drive cover door.
5. Open the drive load lever, and insert the *Diagnostics* diskette in the drive.
6. Close the drive load lever.
7. Set the power switches on all attached devices to On.
8. Set the system unit’s Power switch to On.
9. Did the following appear on your screen?

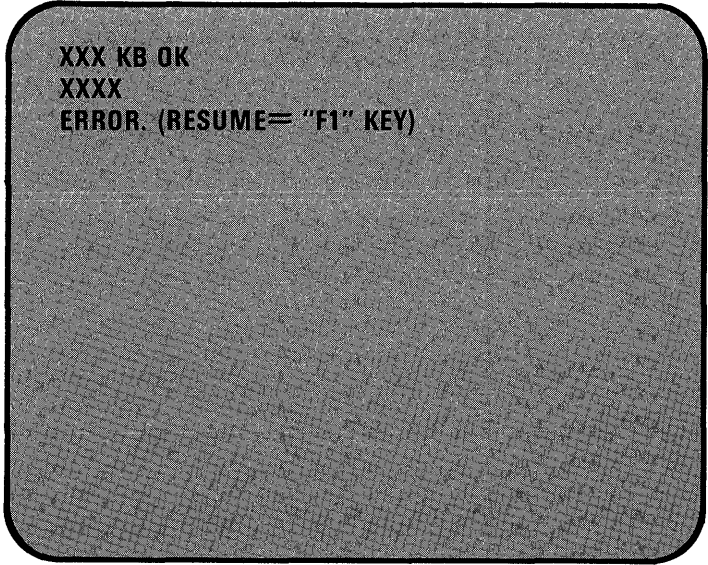

XXX KB OK
XXXX
ERROR. (RESUME= "F1" KEY)

YES – Press the F1 key; then proceed with Step 10.

NO – Proceed with Step 10.

Loading Diagnostics (*continued*)

10. Did the INDUSTRIAL COMPUTER DIAGNOSTICS menu screen appear?

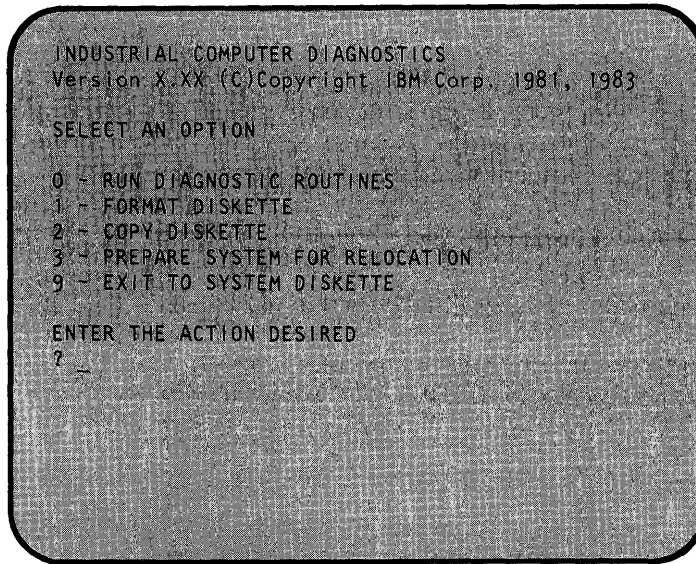

YES – Proceed with Step 11.

NO – Remove the diskette and verify that it is the *Diagnostics* diskette and that it was inserted correctly.

If the *Diagnostics* diskette was inserted correctly, have the system unit serviced.

Note: If you are using a non-IBM display, you could experience data errors when you operate your diskette drive. To correct this problem, move the display a minimum of 30 cm (12 in.) away from the system unit.

11. Press **0** (RUN DIAGNOSTIC ROUTINES); then press the **Enter** key. If you are unable to enter the proper information have your keyboard serviced; otherwise, proceed with Step 12.

Problem Determination Procedures

Loading Diagnostics (*continued*)

12. The installed devices menu appears. Does the screen correctly list all the installed devices and options that you have in your system? (If your printer is not listed, answer Yes.)

Notes:

- a. The screen below is only a representation of the screen you will have depending on the configuration of your system. Refer to Appendix A to verify the options installed in the system unit and compare with the options listed on your screen.
- b. Cables will not appear in the list.

S means the device or option is installed in the system unit.

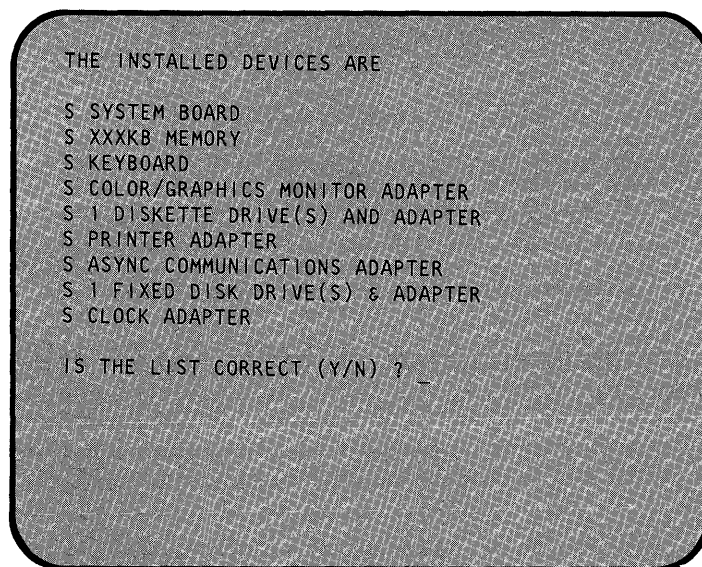

YES – Press **Y**; then press the **Enter** key. Proceed with Step 13.

NO – Press **N**; then press the **Enter** key. Record the error message and have your system unit serviced.

13. Press **0** (RUN TESTS ONE TIME); then press the **Enter** key.

You have loaded the diagnostic tests successfully. Continue with the tests on the following pages to perform a complete system checkout.

Note: The tests are performed in sequence. Follow the steps and instructions that appear on the screen and use this manual as reference where indicated.

Test 100 - System Unit

Did you receive a **SYSTEM UNIT 100** message as shown below?

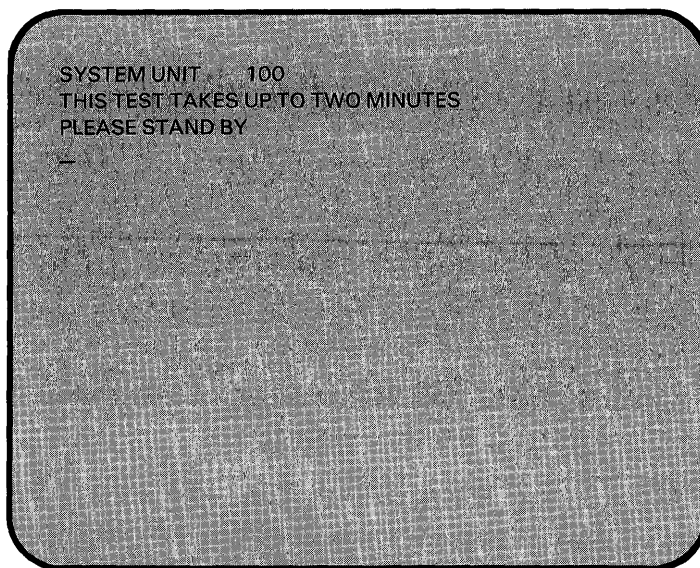

YES – The system has completed this test successfully. Continue with the next test.

NO – Have the system unit serviced.

This page is intentionally left blank.

Test 300 - Keyboard

1. After approximately 2 minutes, did the following appear on your screen?

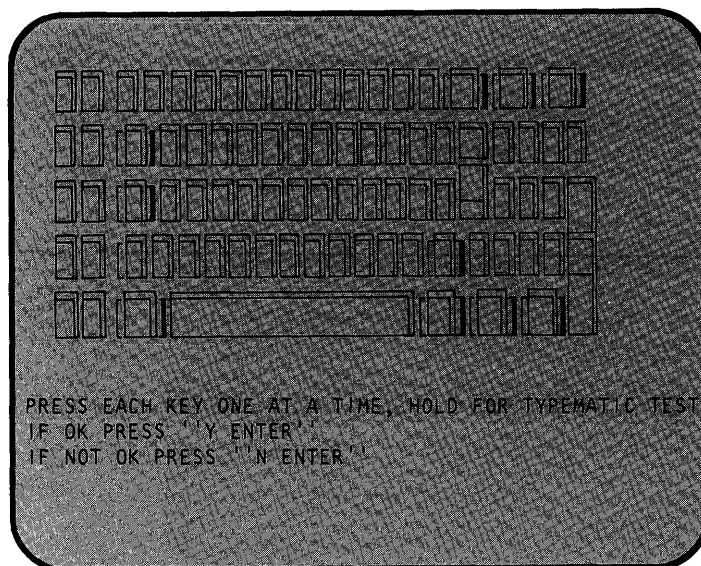

Note: If you are operating in a 40 × 25 mode it is normal for the screen to be split and overlapped.

- YES** – Press each key once; then proceed with Step 2.
- NO** – Press N; then press the **Enter** key. Record the error message, and have the system unit serviced.

Problem Determination Procedures

Test 300 — Keyboard *(continued)*

2. Did all the blocks change to characters as shown below?

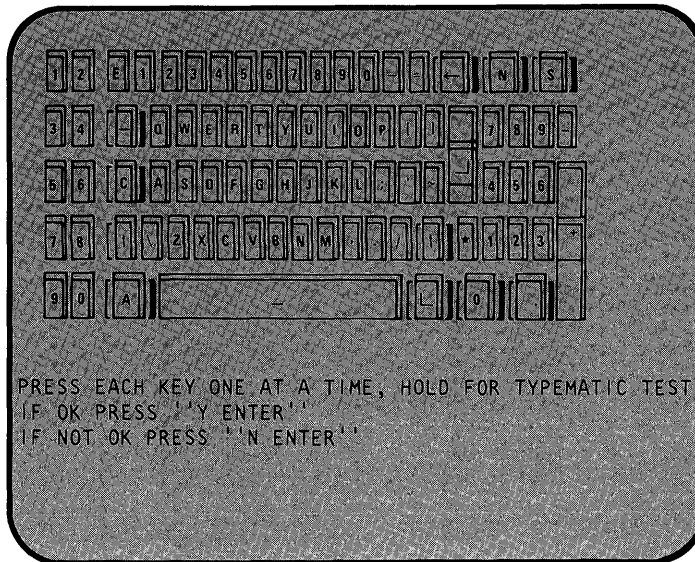

- YES** — Press and hold any key. The corresponding character on the screen will blink. This is the typematic test.

If the typematic test works correctly, press **Y**; then press the **Enter** key. Proceed with the next test. If the typematic test fails, press **N**; then press the **Enter** key. Record the error message, and have the keyboard serviced.

- NO** — Have the keyboard serviced.

Test 400 - Monochrome Display and Printer Adapter

1. Do you have an IBM Monochrome Display and Printer Adapter installed in your system?

NO – Continue with the next test.

YES – Did the following appear on your screen?

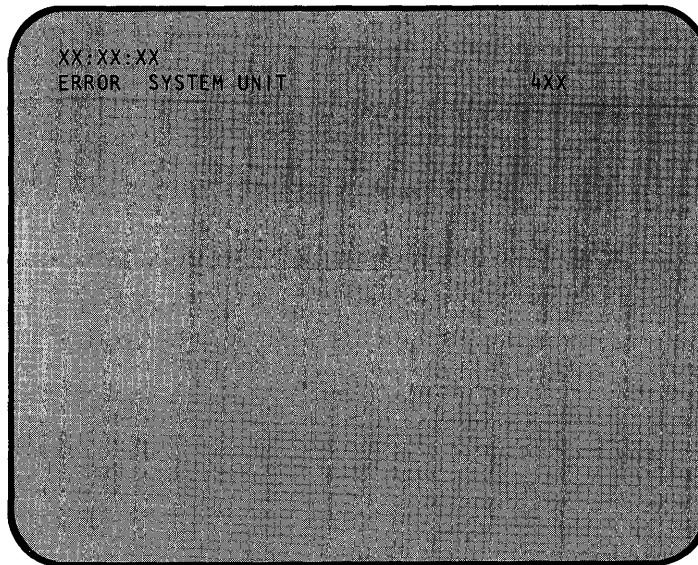

NO – Continue with the next step.

YES – Record the error message, and have the system unit serviced.

Problem Determination Procedures

Test 400 - Monochrome Display and Printer Adapter *(continued)*

2. Do you have an IBM Monochrome Display attached to the Monochrome Display and Printer Adapter?

NO – Continue with the next test.

YES – Did the following appear on your screen?

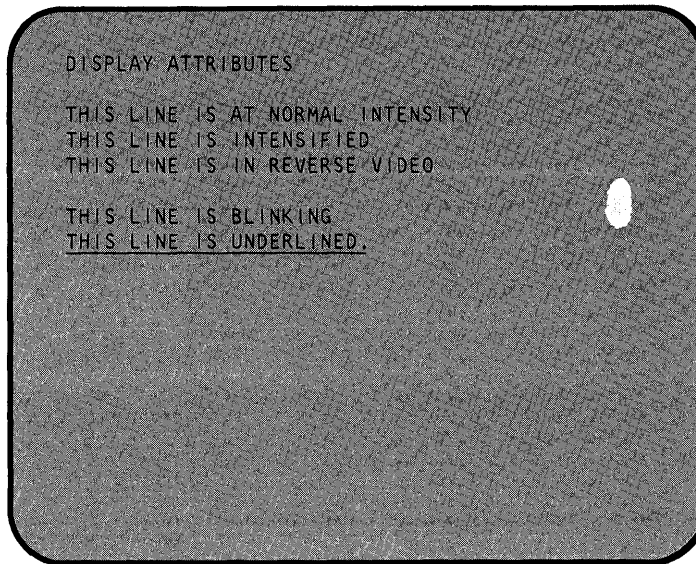

YES – Press **Y**; then press the **Enter** key. Proceed with the next step.

NO – Press **N**; then press the **Enter** key. Record the error message, and have the system unit serviced.

Test 400 - Monochrome Display and Printer Adapter *(continued)*

3. Did the following appear on your screen?

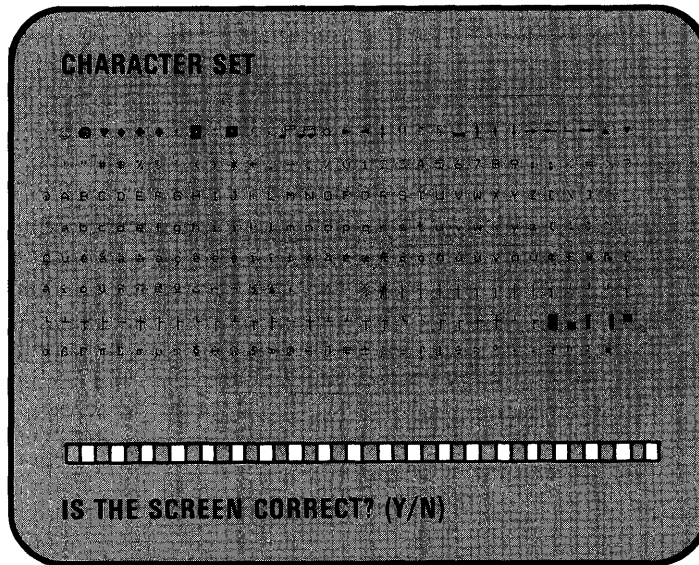

YES – Press **Y**; then press the **Enter** key. Proceed with the next step.

NO – Press **N**; then press the **Enter** key. Record the error message, and have the system unit serviced.

Test 500 - Color/Graphics Monitor Adapter

1. Do you have an IBM Color/Graphics Monitor Adapter installed in your system?

NO – Continue with the next test.

YES – Did the following appear on your screen?

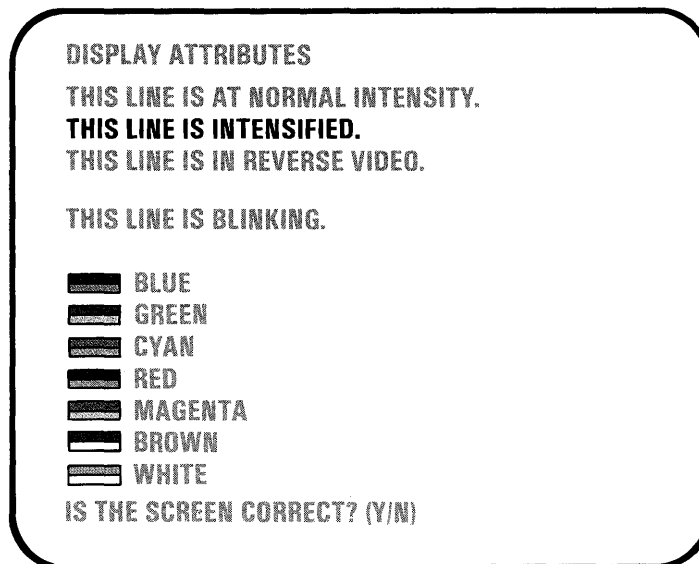

YES – Press **Y**; then press the **Enter** key. Proceed with Step 2.

NO – Press **N**; then press the **Enter** key. Record the error message, and have the system unit serviced.

Problem Determination Procedures

Test 500 - Color/Graphics Monitor Adapter (continued)

2. Did the following appear on your screen?

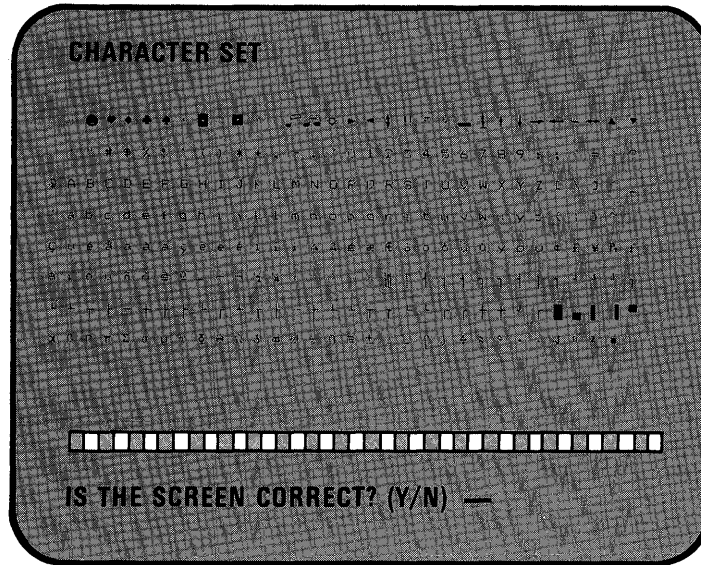

YES – Press **Y**; then press the **Enter** key. Proceed with Step 3.

NO – Press **N**; then press the **Enter** key. Record the error message, and have the system unit serviced.

Test 500 - Color/Graphics Monitor Adapter (continued)

3. Did the following appear on your screen?

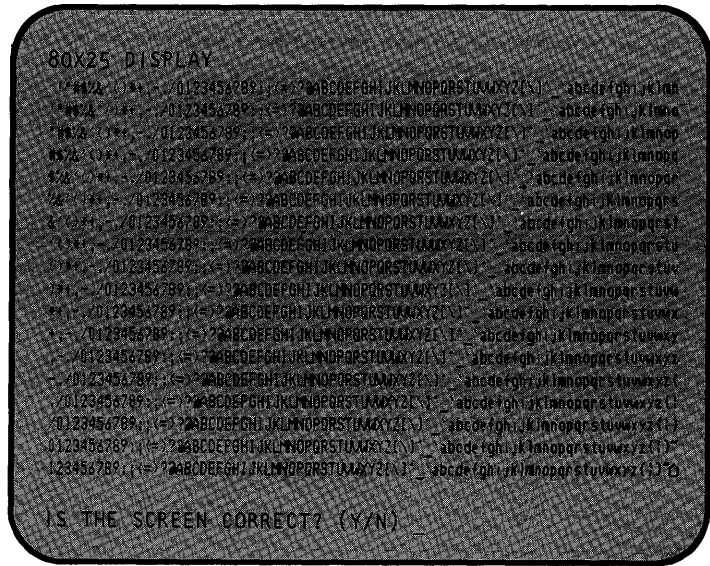

YES - Press Y; then press the Enter key. Proceed with Step 4.

NO - Press N; then press the Enter key. Record the error message, and have the system unit serviced.

Problem Determination Procedures

Test 500 - Color/Graphics Monitor Adapter (continued)

4. Did the following appear on your screen?

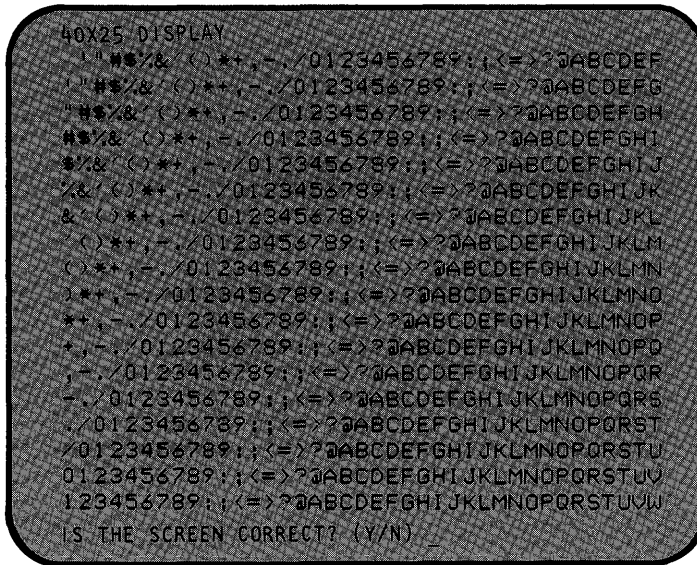

YES – Press **Y**; then press the **Enter** key. Proceed with Step 5.

NO – Press **N**; then press the **Enter** key. Record the error message, and have the system unit serviced.

Test 500 - Color/Graphics Monitor Adapter *(continued)*

5. Did the following appear on your screen with the correct colors?

Note: Text in illustration is black for clarity.

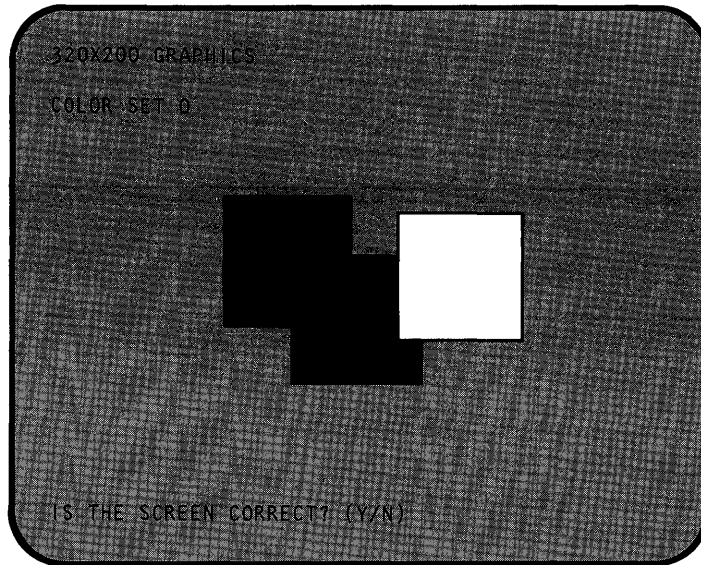

- YES** – Press **Y**; then press the **Enter** key. Proceed with Step 6.
- NO** – Press **N**; then press the **Enter** key. Record the error message, and have the system unit serviced.

Problem Determination Procedures

Test 500 - Color/Graphics Monitor Adapter (*continued*)

6. Did the following appear on your screen with the correct colors?

Note: Text in illustration is black for clarity.

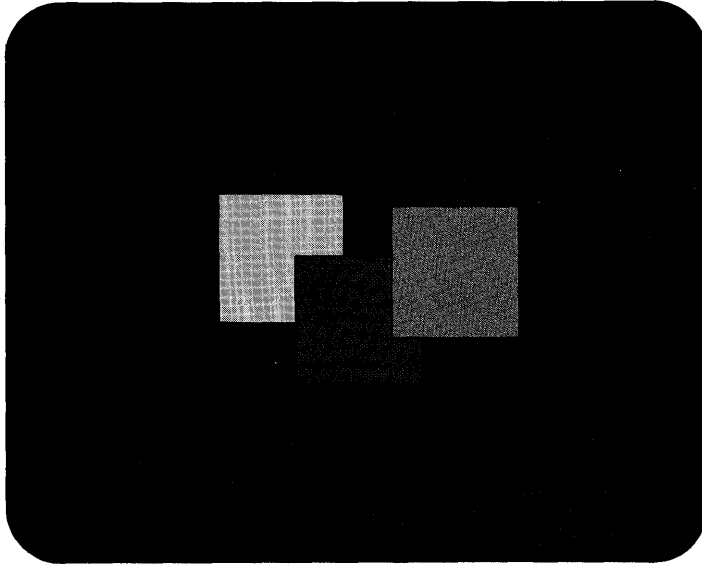

- YES** – Press **Y**; then press the **Enter** key. Proceed with Step 7.
- NO** – Press **N**; then press the **Enter** key. Record the error message, and have the system unit serviced.

Test 500 - Color/Graphics Monitor Adapter *(continued)*

7. Did the following appear on your screen?

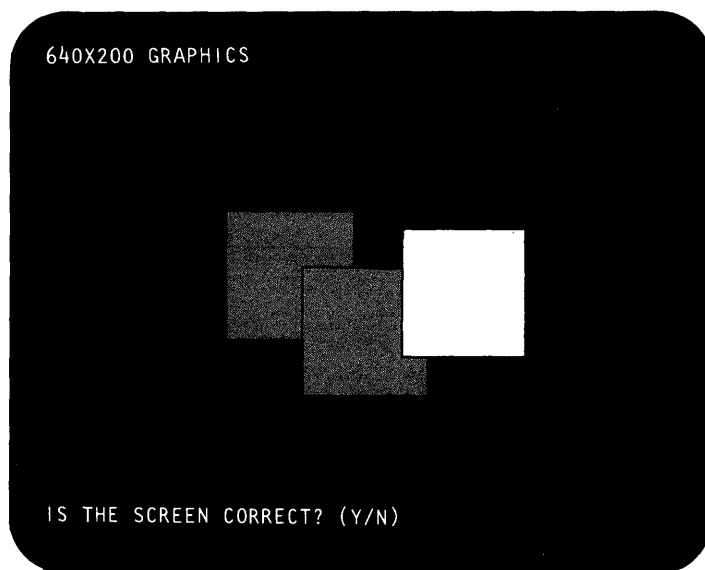

YES – Press **Y**; then press the **Enter** key. Proceed with Step 8.

NO – Press **N**; then press the **Enter** key. Record the error message, and have the system unit serviced.

Problem Determination Procedures

Test 500 - Color/Graphics Monitor Adapter *(continued)*

8. Did the following appear on your screen?

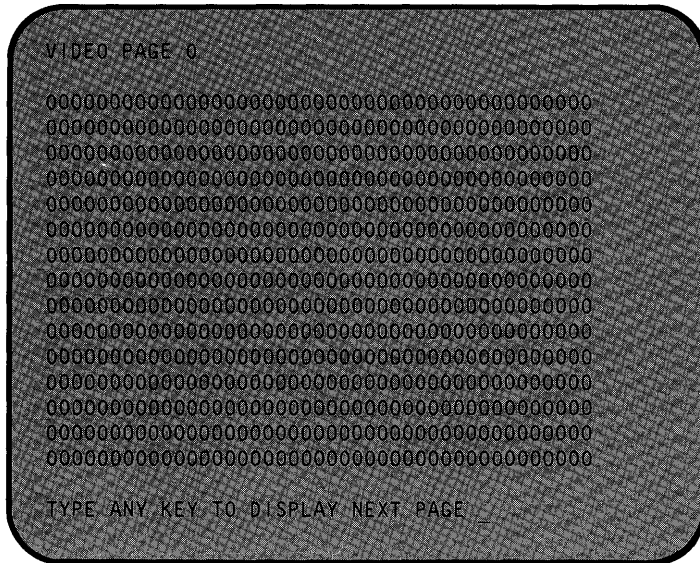

YES – Proceed with Step 9.

NO – Press **N**; then press the **Enter** key. Record the error message, and have the system unit serviced.

Test 500 - Color/Graphics Monitor Adapter (continued)

9. There are eight video pages. Press any key. VIDEO PAGE 1 appears. Continue to press any key until VIDEO PAGE 0 appears.
10. Did all eight pages appear?

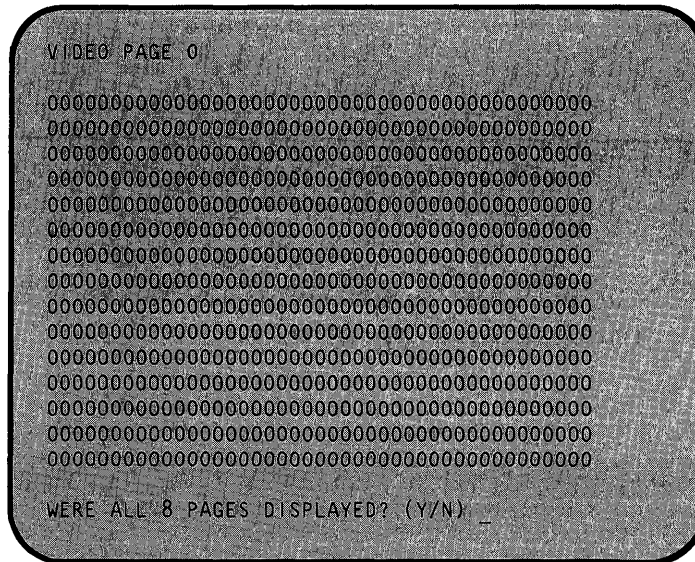

- YES** – Press **Y**; then press the **Enter** key. The **SYSTEM UNIT 500** message appears briefly on the screen when the system has completed this test successfully. Continue with the next test.
- NO** – Press **N**; then press the **Enter** key. Record the error message, and have the system unit serviced.

This page is intentionally left blank.

Test 600 - Diskette Drive

1. Remove the *Diagnostics* diskette.
2. Does your screen match the one shown in the figure below?

Note: X can be any alphanumeric character.

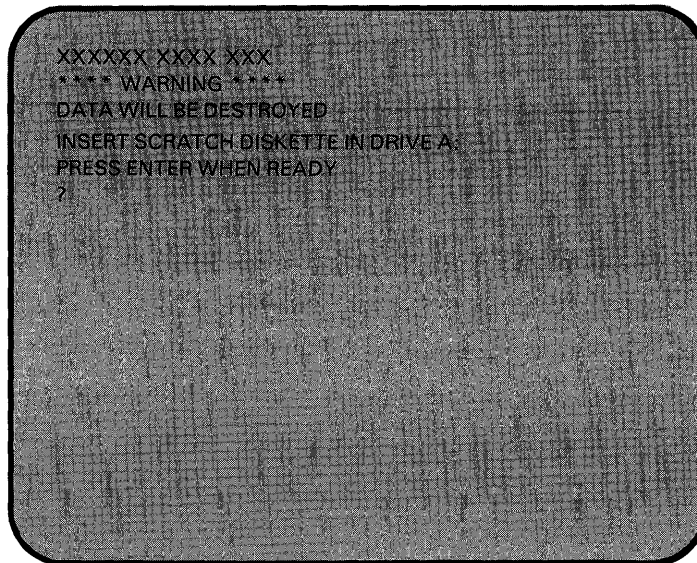

YES – Proceed with Step 3.

NO – Record the error message, and have the system unit serviced.

Problem Determination Procedures

Test 600 - Diskette Drive *(continued)*

3. Insert a scratch diskette in drive A, and press the **Enter** key.
4. Did the following appear on your screen? Is the drive type correct?



```
XXXXXX XXXX   XXX
**** WARNING ****
DATA WILL BE DESTROYED
```

```
INSERT SCRATCH DISKETTE IN DRIVE A:
PRESS ENTER WHEN READY
```

```
? ___
```

```
DISKETTE A: IS DOUBLE SIDED
IS THE DISKETTE DRIVE TYPE
CORRECT - (Y/N) ? ___
```

- YES** – Press **Y**; then press the **Enter** key. If you have two diskette drives installed in your system, go to the next step. If you have only one diskette drive, your system has completed this test successfully. Continue with the next test.
- NO** – Have the system unit serviced.

Test 600 - Diskette Drive *(continued)*

5. Did the following appear on your screen?

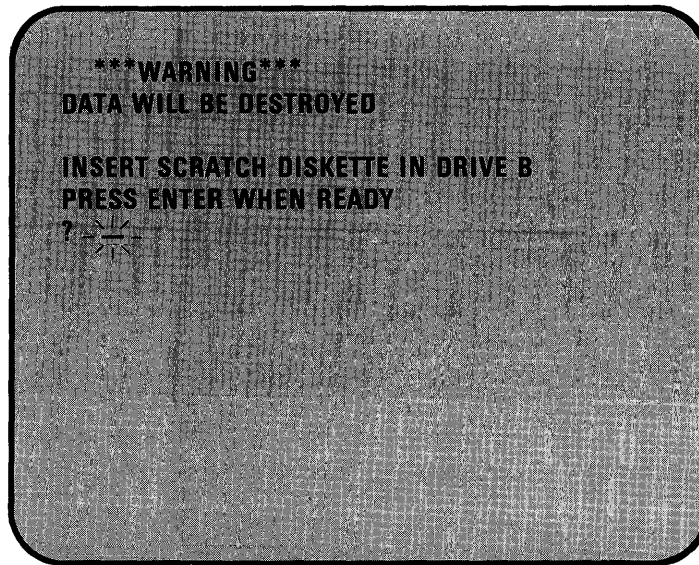

- YES** – Remove the scratch diskette from drive A, place it in drive B, and press the **Enter** key. Go to the next step.
- NO** – Have the system unit serviced.

Problem Determination Procedures

Test 600 - Diskette Drive *(continued)*

6. Did the following appear on your screen and is the drive type correct?

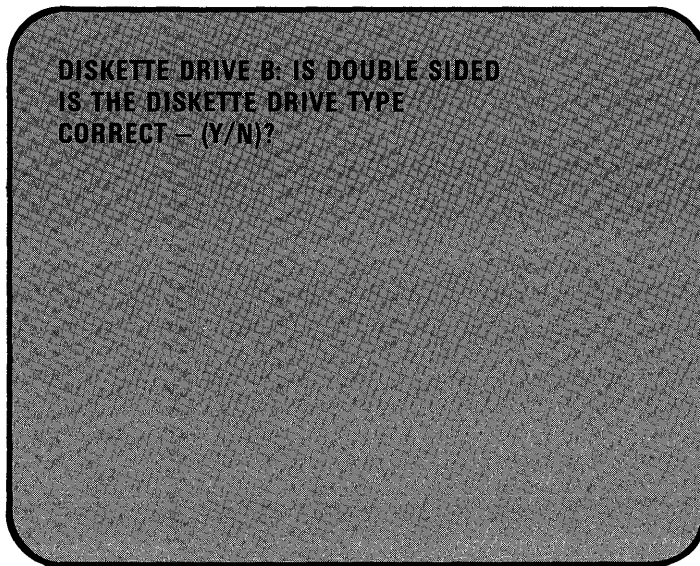

- YES** – Press **Y**; then press the **Enter** key. The **SYSTEM UNIT 600** message appears briefly when the system has completed this test successfully. Continue with the next test.
- NO** – Have the system unit serviced.

Test 700 - Math Coprocessor

1. Do you have an IBM Math Coprocessor installed in your system?

NO – Continue with the next test.

YES – Did the following appear and remain on your screen for more than 10 seconds?

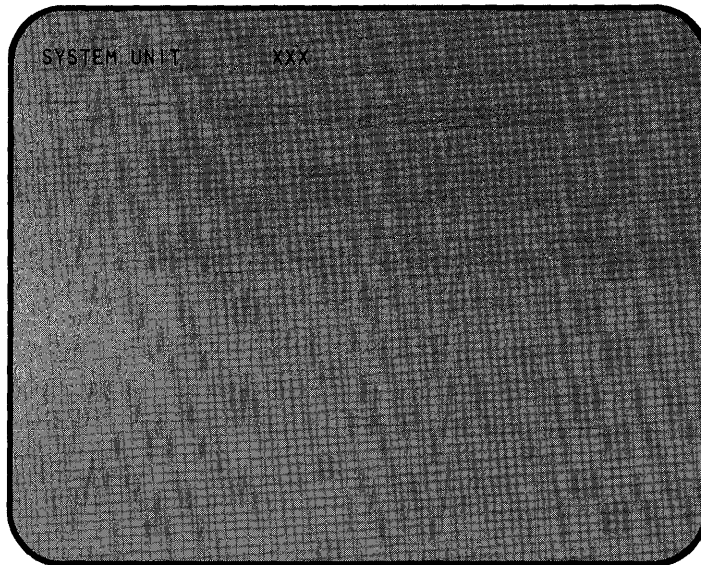

YES – Have the system unit serviced.

NO – Proceed with Step 2.

Problem Determination Procedures

Test 700 - Math Coprocessor *(continued)*

2. Did the following appear on your screen?

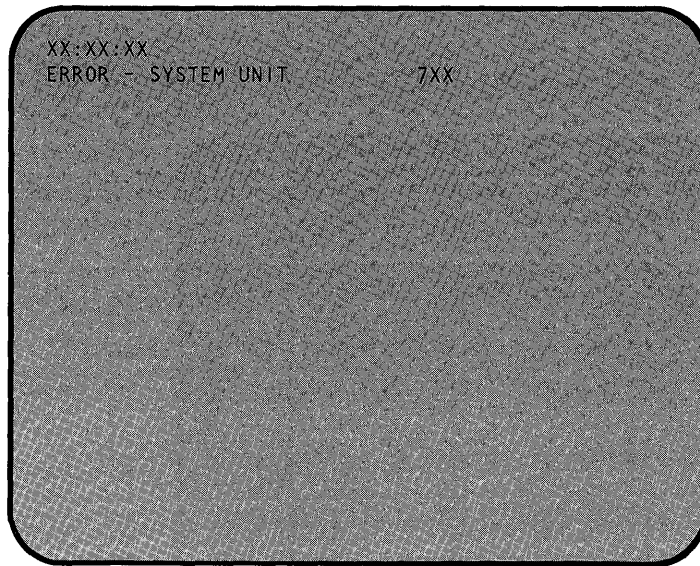

YES – Have the system unit serviced.

NO – The system has completed this test successfully. Continue with the next test.

Test 900 - Printer Adapter

Did the following error message appear on your screen?

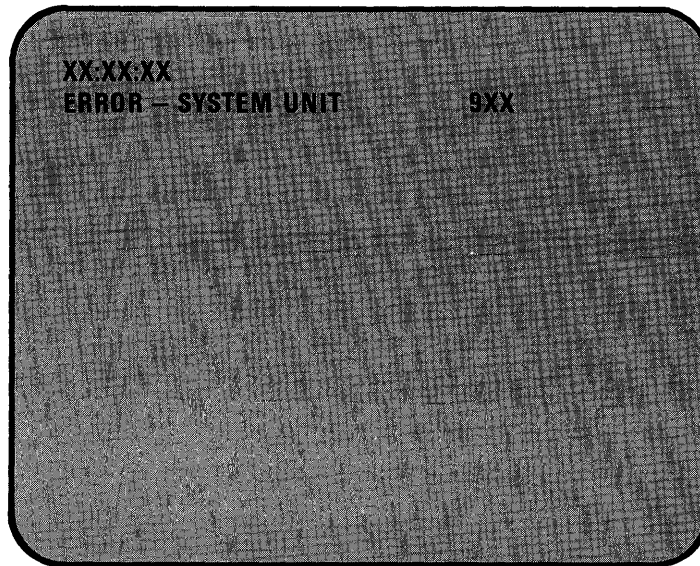

YES - Have the system unit serviced.

NO - The system has completed this test successfully. Continue with the next test.

This page is intentionally left blank.

Test 1100 - ASYNC Adapter

Do you have an IBM Combination Adapter or Asynchronous Communications Adapter installed in your system?

NO – Continue with the next test.

YES – Did either or both of the following error messages appear on your screen?

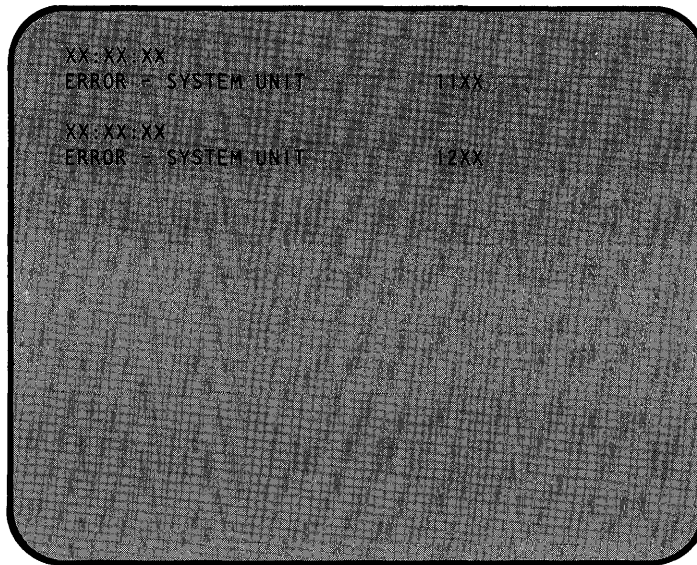

YES – Have the system unit serviced.

NO – The system has completed this test successfully. Continue with the next test.

This page is intentionally left blank.

Test 1400 - Graphics Printer

The following appears on your screen.

Note: If the Power is not switched On, a 14XX error occurs.

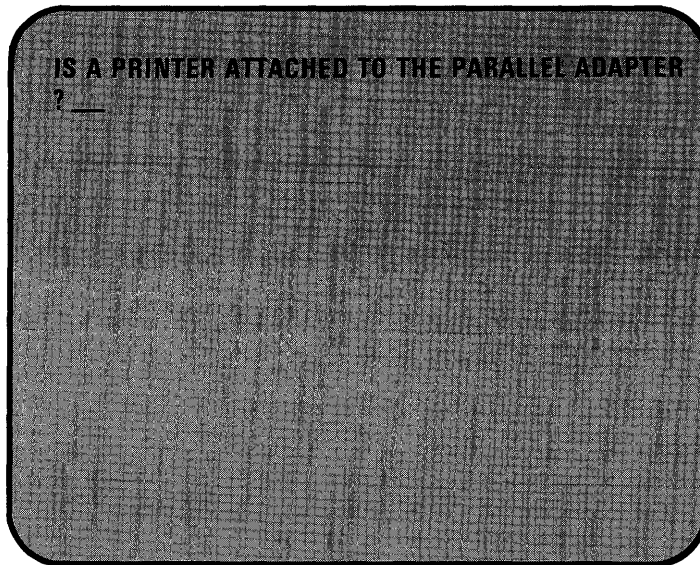

YES – Type **Y**; then press the **Enter** key.

NO – Type **N**; then press the **Enter** key. Follow the directions on the screen.

Test 1500 - SDLC Adapter

Do you have an IBM Synchronous Data Link Control Adapter installed in your system?

NO – Continue with the next test.

YES – Did the following error message appear on your screen?

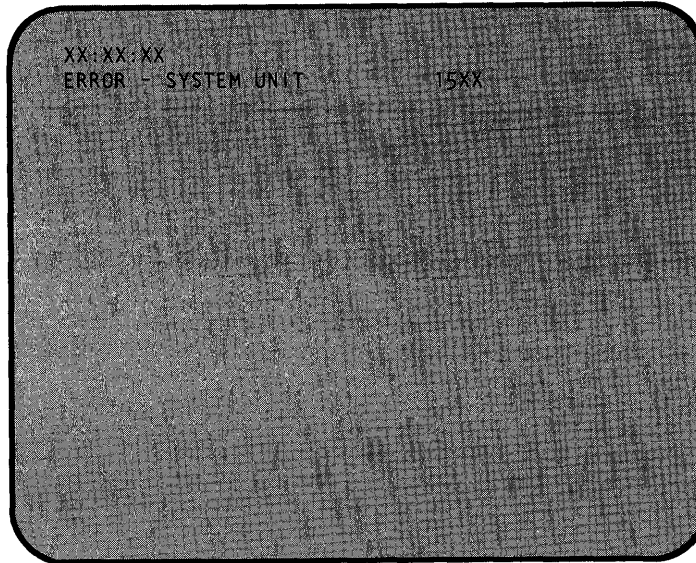

YES – Have the system unit serviced.

NO – The system has completed this test successfully. Continue with the next test.

This page is intentionally left blank.

Test 1700 - Fixed Disk Drive

1. Do you have a fixed disk drive installed in your system unit?

NO – Continue with the next test.

YES – The following appears on your screen.

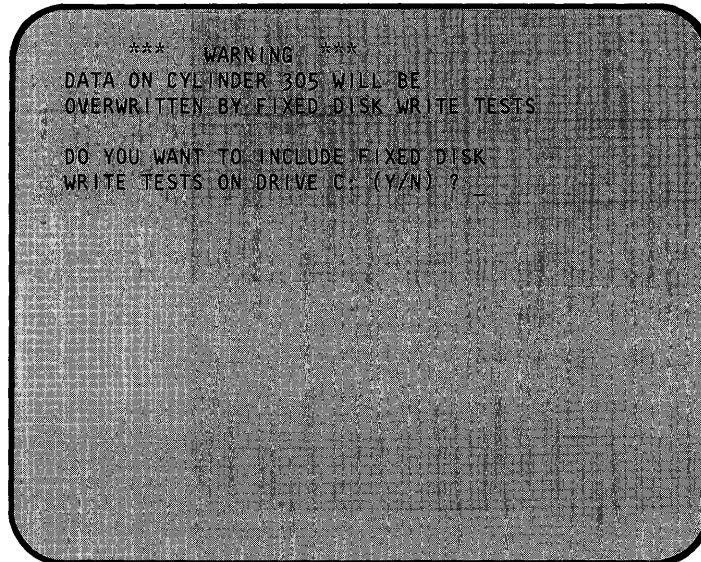

Press **Y**; then press the **Enter** key if you want to include fixed-disk write tests. If you do not want to include fixed-disk write tests, press **N**. Then press the **Enter** key.

Proceed with Step 2.

Problem Determination Procedures

Test 1700 - Fixed Disk Drive *(continued)*

2. Did the following appear on your screen?

Note: If you pressed **N** (no write test), **PERFORMING WRITE TEST** will not appear.

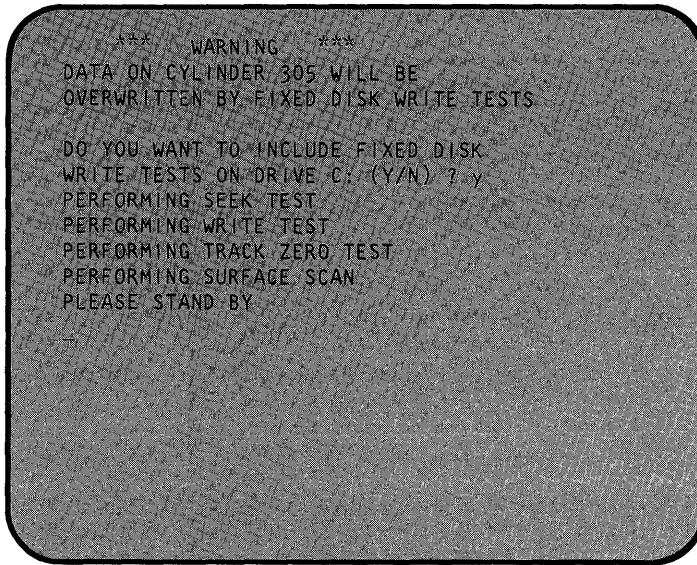

YES – The system is performing a test on the fixed disk drive. Proceed to Step 3.

NO – Have the system unit serviced.

Test 1700 - Fixed Disk Drive *(continued)*

Note: The test on the fixed disk drive can take up to 5 minutes.

3. When the test completed, did the following appear on your screen?

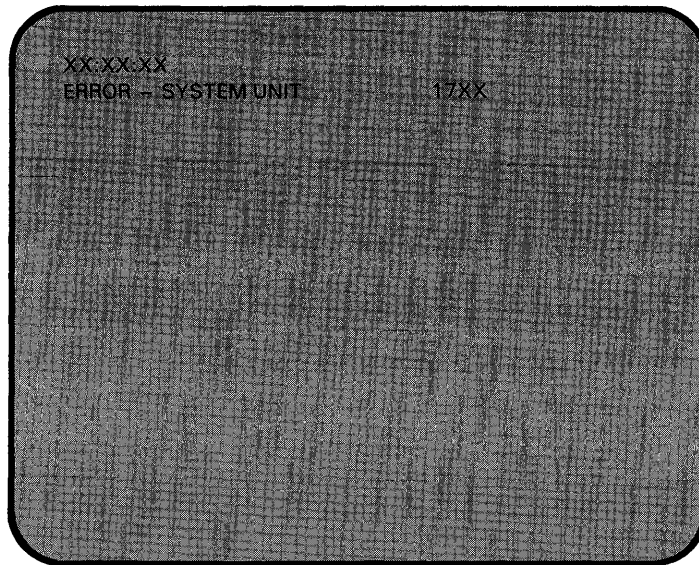

YES – Record the error message, and have the system unit serviced.

NO – The system has successfully completed this test. Press **9**; then press the **Enter** key. Continue with the next test.

This page is intentionally left blank.

Test 2000 - BSC Adapter

Do you have an IBM Binary Synchronous Communications Adapter installed in your system?

NO – Continue with the next test.

YES – Did either or both of the following error messages appear on your screen?

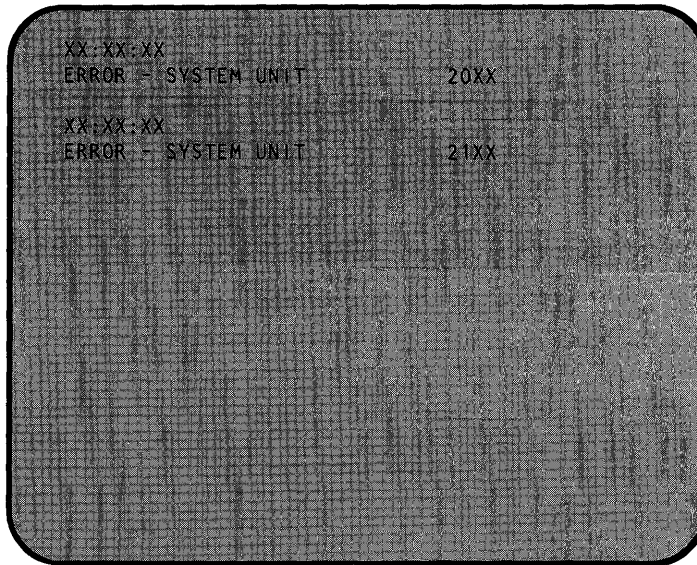

YES – Have the system unit serviced.

NO – The system has completed this test successfully. Continue with the next test.

This is intentionally left blank.

Test 2200 - IBM Personal Computer Cluster Adapter

1. Do you have an IBM Personal Computer Cluster Adapter installed in your system?

NO – Continue with the next test.

YES – Did the following error message appear on your screen?

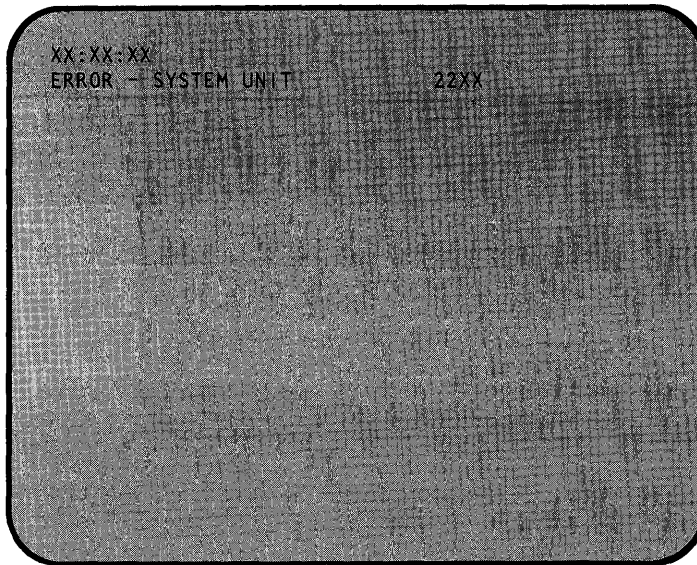

YES – Have the system unit serviced.

NO – Proceed with Step 2.

Problem Determination Procedures

Test 2200 - IBM Personal Computer Cluster Adapter *(continued)*

2. Did the following error message appear on your screen?

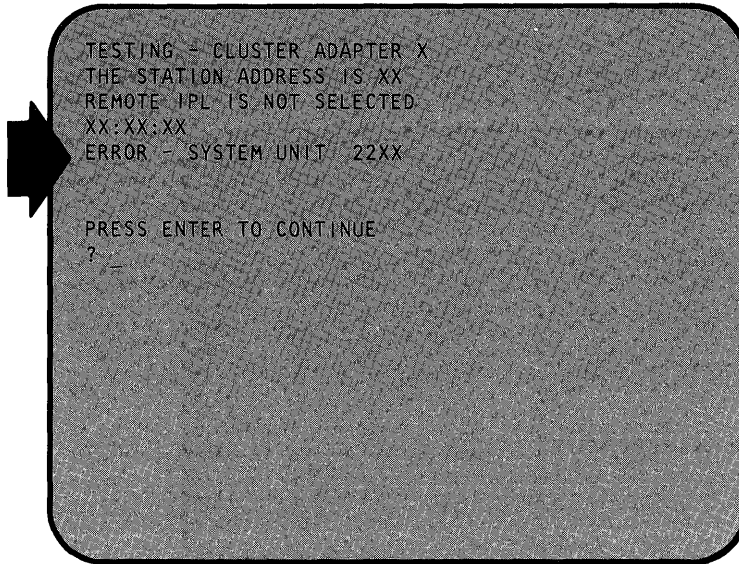

YES – Have the system unit serviced.

NO – Proceed with Step 3.

Test 2200 - IBM Personal Computer Cluster Adapter *(continued)*

3. The following appears on your screen.

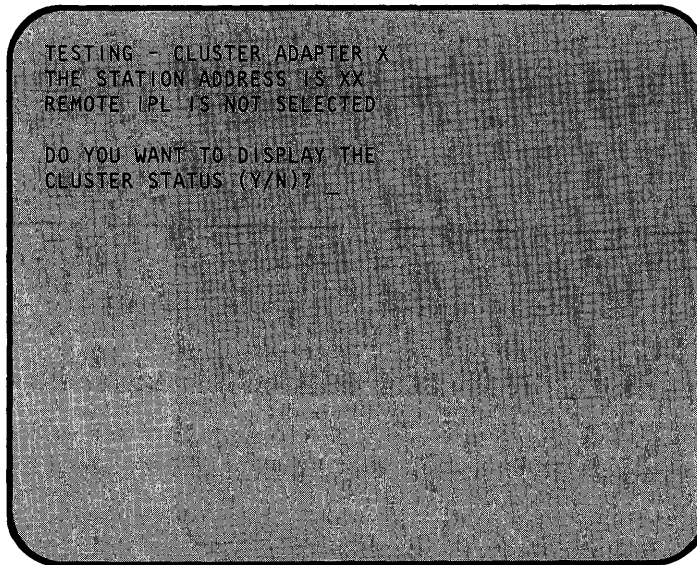

Note: When more than one Cluster Adapter is installed in an Industrial Computer, each of the adapters will be tested.

4. Does the adapter number, station address, and remote IPL (Initial Program Load) information shown on your screen match the switch setting information you entered below?

Note: Refer to Appendix A for any information required below.

Cluster Adapter Number _ _ _ _

Station Address _ _ _ _

Remote IPL (Is/Is not) Selected _____

YES - Proceed with Step 5.

NO - If the adapter number, station address, or remote IPL information is not correct, have the system unit serviced.

Problem Determination Procedures

Test 2200 - IBM Personal Computer Cluster Adapter (*continued*)

5. Do you want to display the cluster status?

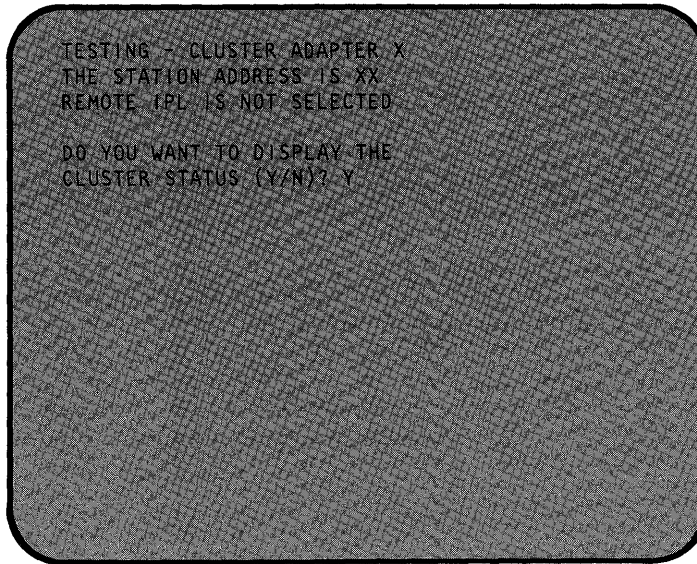

Note: The cluster-status screen presentation will show up to 64 boxes that represent the stations in the cluster that have their Power switch set to On and are connected to the cluster bus.

YES – Set the Power switches on all cluster system units to On. Press **Y**; then press the **Enter** key.

Then proceed with Step 6.

NO – The system has successfully completed this test. Remove the terminating plug, and attach the coaxial cable to the Cluster Adapter connector.

Press **N**; then press the **Enter** key. Continue with the next test.

Test 2200 - IBM Personal Computer Cluster Adapter *(continued)*

6. The following appears on your screen.

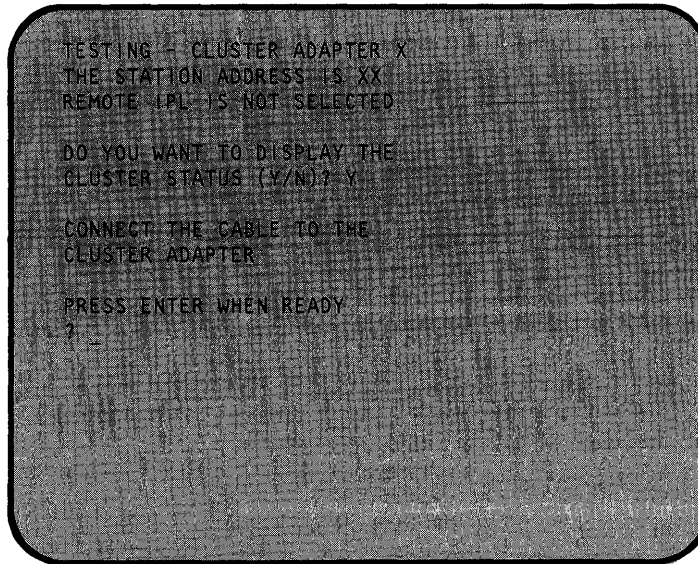

Disconnect the terminating plug, and attach the coaxial cable to the Cluster Adapter's connector.

Press the **Enter** key. Proceed to the next page.

Problem Determination Procedures

Test 2200 - IBM Personal Computer Cluster Adapter *(continued)*

This page explains the cluster status that may appear on your screen.

NN is any station address from 0 to 63.

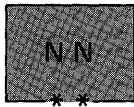

The system you are using is indicated on the screen in blinking reverse video, and the box is marked by two asterisks.

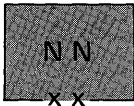

Stations that have their Power switch set to On are displayed in reverse video, and their boxes are marked by two Xs.

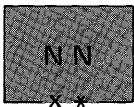

If another Industrial Computer has the same station address as your Industrial Computer, a long beep will sound every 3 seconds. The box will be displayed in blinking reverse video and will be marked by an X and an asterisk.

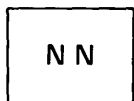

A station address not in the cluster is indicated by a box displayed in normal video and not marked with Xs or asterisks.

A Cluster-Access Error message may be displayed in reverse video.

Proceed with Step 7.

Test 2200 - IBM Personal Computer Cluster Adapter *(continued)*

7. Wait 15 seconds. Do all stations in the cluster appear and remain on the screen presentation?

Note: This screen is for illustrative purposes only.

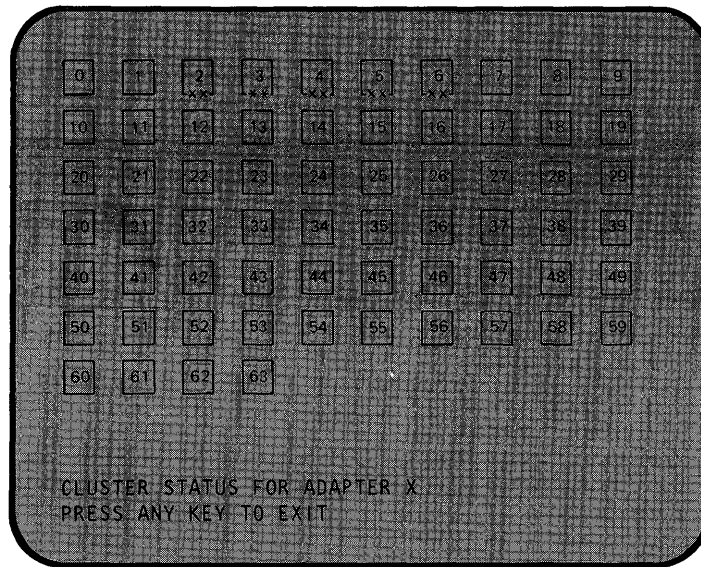

Notes:

- Your installation manager has a cluster map that lists the station addresses and the order in which the stations are connected. Compare the map and the status screen presentation to determine that all stations in the cluster are operating properly.
- The status screen shows all stations installed on your cluster, and is updated every 3 seconds to show stations that are added to or removed from the cluster.

YES – The system has successfully completed this test. Press any key and continue with the next test.

NO – Proceed with Step 8.

Problem Determination Procedures

Test 2200 - IBM Personal Computer Cluster Adapter *(continued)*

8. Did a box appear in blinking reverse video with an X and asterisk, and did a beep sound every 3 seconds?

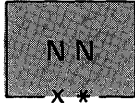

YES – Another Industrial Computer has the same station address as your Industrial Computer. Compare your cluster map with the status screen presentation. Do the system diagnostic tests on the Industrial Computer missing from the cluster-status screen presentation.

Have the system unit that contains the failing adapter serviced.

NO – Proceed with Step 9.

Test 2200 - IBM Personal Computer Cluster Adapter *(continued)*

9. Did a box appear in normal video with no Xs or asterisks for a station address that is in the cluster?

Note: Multiple grounds on cluster cables may cause stations to appear on the status screen presentation intermittently. If this happens, notify your installation manager.

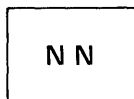

YES - Go to Step 11.

NO - Proceed with Step 10.

Problem Determination Procedures

Test 2200 - IBM Personal Computer Cluster Adapter *(continued)*

10. Do you have a cluster-access error?

Note: This screen is for illustrative purposes only.

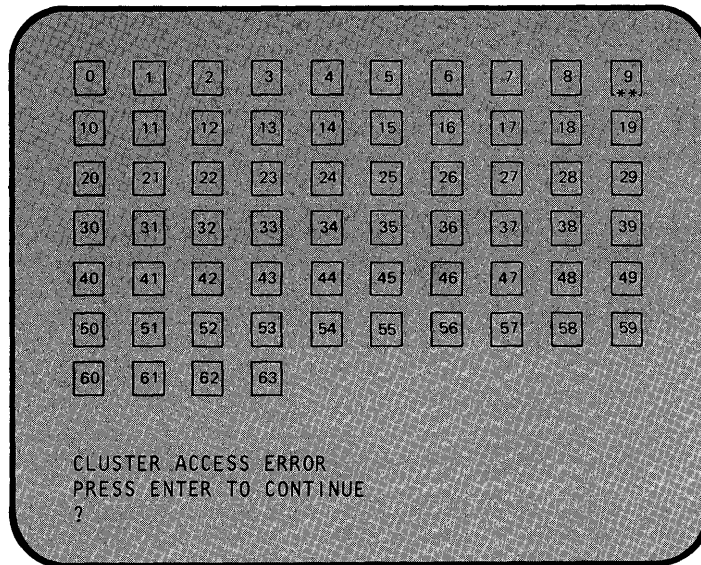

YES – Proceed with Step 11.

NO – The system has successfully completed this test. Continue with the next test.

Test 2200 - IBM Personal Computer Cluster Adapter *(continued)*

11. You have stations that are not indicated on any status screen presentation, or by a cluster-access error message.
 - Perform the system diagnostic tests on a station that is not indicated on any status screen presentation or that has a cluster-access error.
 - If the diagnostic tests fail, have the system unit serviced.
 - If the diagnostic tests pass, continue performing the diagnostic tests until you test all of the stations that did not appear on any cluster-status screen presentation or that had a cluster-access error.
 - If the Cluster Adapters pass the diagnostic tests and the stations did not appear on the cluster-status screen presentations, contact your installation manager. The problem may be with the coaxial cable or a terminating plug.

Note: If you have more than one cluster adapter installed in your system, go back to 5-2200-1 and continue testing until all cluster adapters have been tested.

This page is intentionally left blank.

Test 2400 - Enhanced Graphics Adapter

Note: Refer to Appendix A, "Option List" to determine the amount of graphics memory installed on your Enhanced Graphics Adapter.

1. Do you have an IBM Enhanced Graphics Adapter installed in your system?

NO – Continue with the next test.

YES – Is the amount of graphics memory displayed the correct amount for your system?

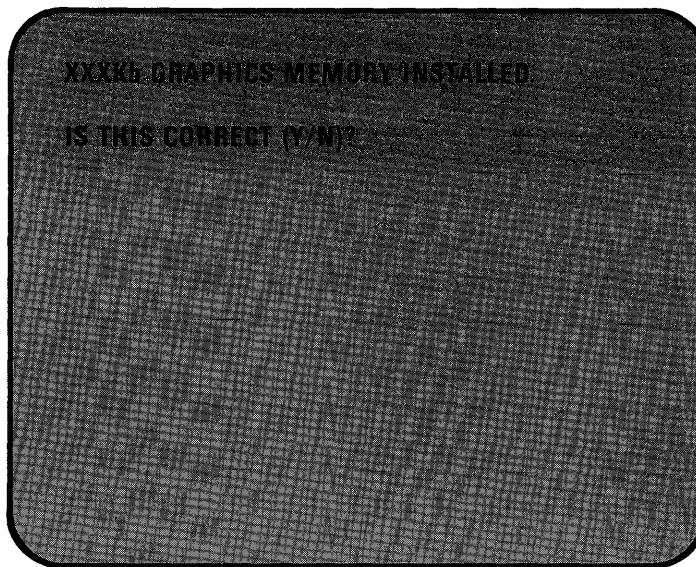

Note: The screen may indicate 64Kb, 128Kb, or 256Kb graphics memory installed, depending on your system configuration.

YES – Press **Y**; then press the **Enter** key and go to Step 3.

NO – Press **N**; then press the **Enter** key and go to the next step.

Problem Determination Procedures

Test 2400 - Enhanced Graphics Adapter *(continued)*

2. Did the following screen appear?

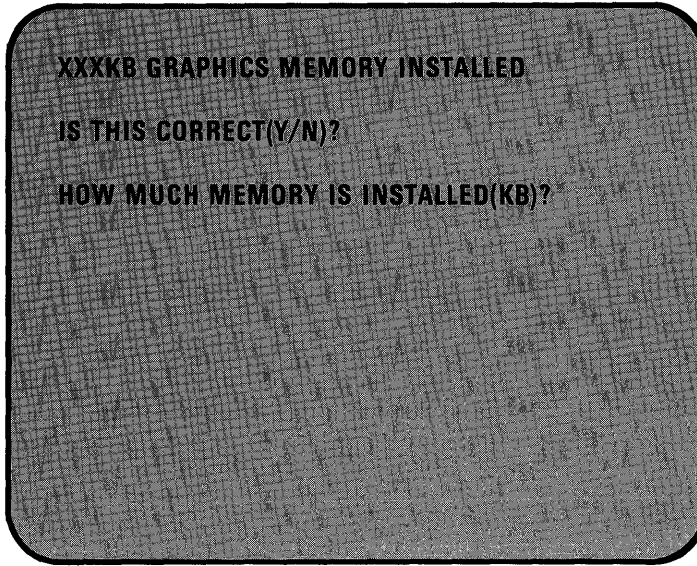

- YES** – Type in the correct amount of graphics memory installed and press **Enter**. Go to the next step.
- NO** – Go to the next step.

Test 2400 - Enhanced Graphics Adapter *(continued)*

3. Refer to Appendix A to determine your mode of operation.

Are you operating in the *Enhanced* mode?

NO – Continue with step 20.

YES – Continue with the next step.

4. Did the following appear on your screen (ignore any color problems for now)?

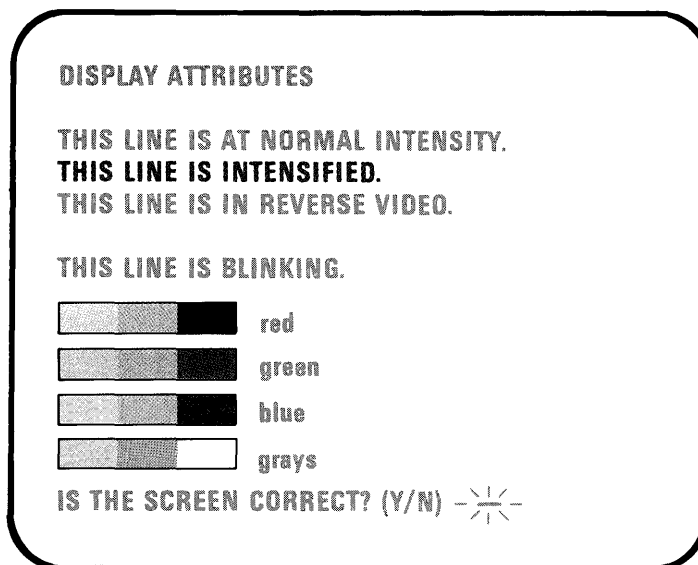

YES – Go to the next step.

NO – Press **N**; then press the **Enter** key. Record the error message, and have the unit that contains the adapter serviced.

Problem Determination Procedures

Test 2400 - Enhanced Graphics Adapter (continued)

5. Examine the DISPLAY ATTRIBUTES screen.

Are the colors correct?

Note: There should be three different shades of each color.

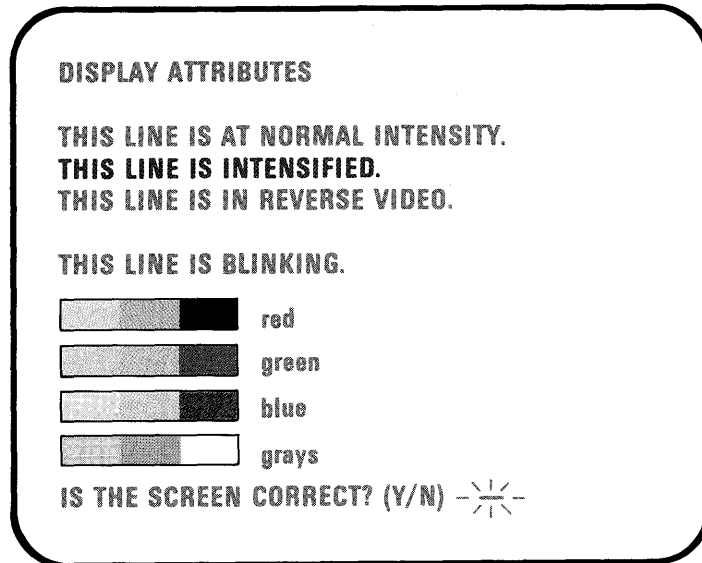

YES – Press **Y**; then press the **Enter** key. Continue with the next step.

NO – Have the display serviced.

Test 2400 - Enhanced Graphics Adapter *(continued)*

6. Did the following appear on your screen (ignore any color problems for now)?

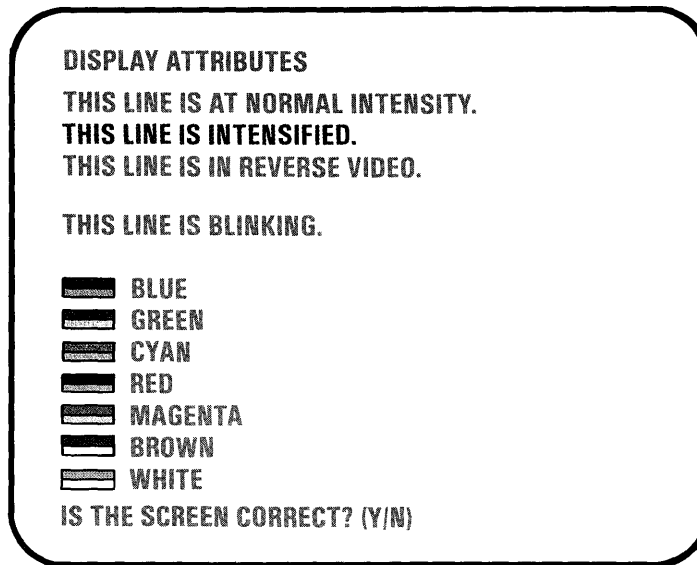

YES – Go to the next step.

NO – Press **N**; then press the **Enter** key. Record the error message, and have the unit that contains the adapter serviced.

Problem Determination Procedures

Test 2400 - Enhanced Graphics Adapter *(continued)*

7. Examine the DISPLAY ATTRIBUTES screen.

Are the colors correct?

Note: There should be two different shades of each color.

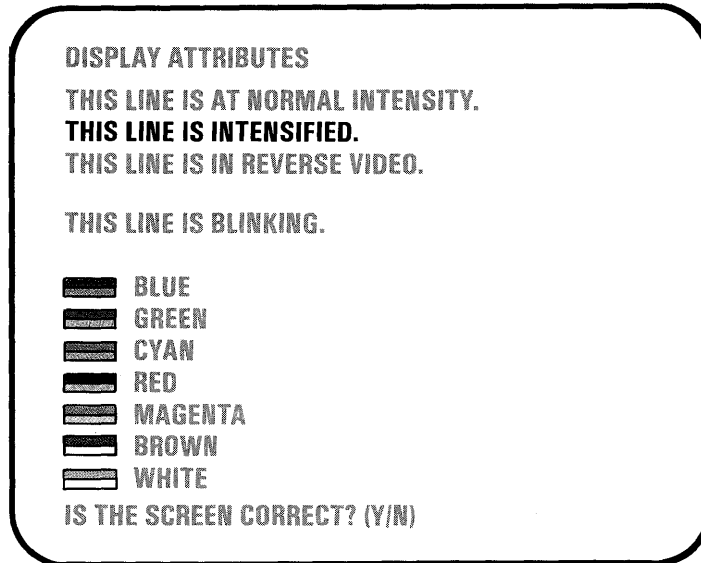

YES – Press **Y**; then press the **Enter** key. Continue with the next step.

NO – Have the display serviced.

Test 2400 - Enhanced Graphics Adapter *(continued)*

8. Did the following appear on your screen?

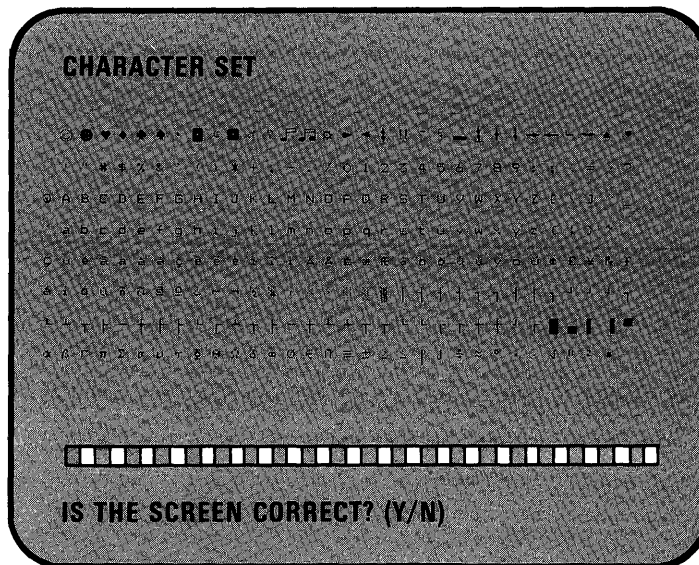

YES – Press **Y**; then press the **Enter** key. Continue with the next step.

NO – Press **N**; then press the **Enter** key. Record the error message, and have the unit that contains the adapter serviced.

Problem Determination Procedures

Test 2400 - Enhanced Graphics Adapter (*continued*)

9. Did the following appear on your screen?

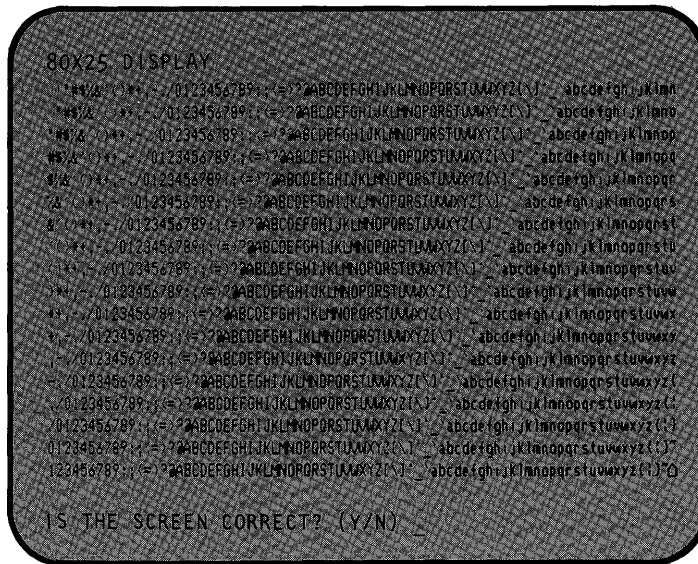

YES – Press **Y**; then press the **Enter** key. Continue with the next step.

NO – Press **N**; then press the **Enter** key. Record the error message, and have the unit that contains the adapter serviced.

Test 2400 - Enhanced Graphics Adapter *(continued)*

10. Did the following appear on your screen?

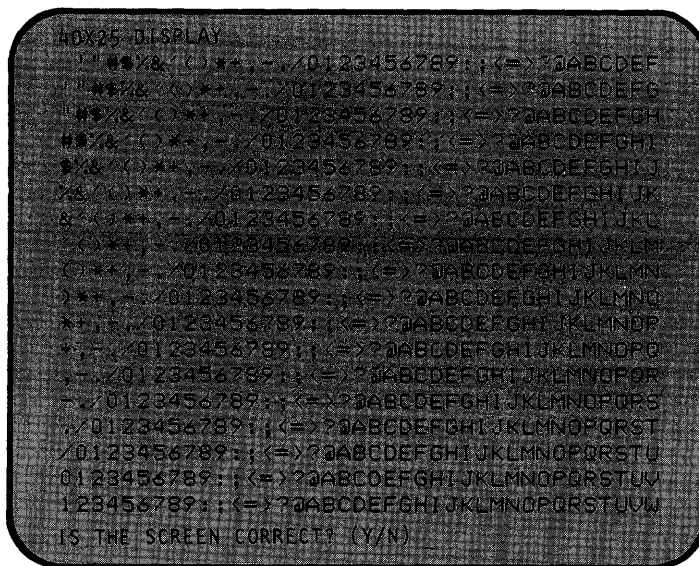

YES – Press **Y**; then press the **Enter** key. Continue with the next step.

NO – Press **N**; then press the **Enter** key. Record the error message, and have the unit that contains the adapter serviced.

Problem Determination Procedures

Test 2400 - Enhanced Graphics Adapter (*continued*)

11. Did the following appear on your screen and are the colors correct?

Note: Text in illustration is black for clarity.

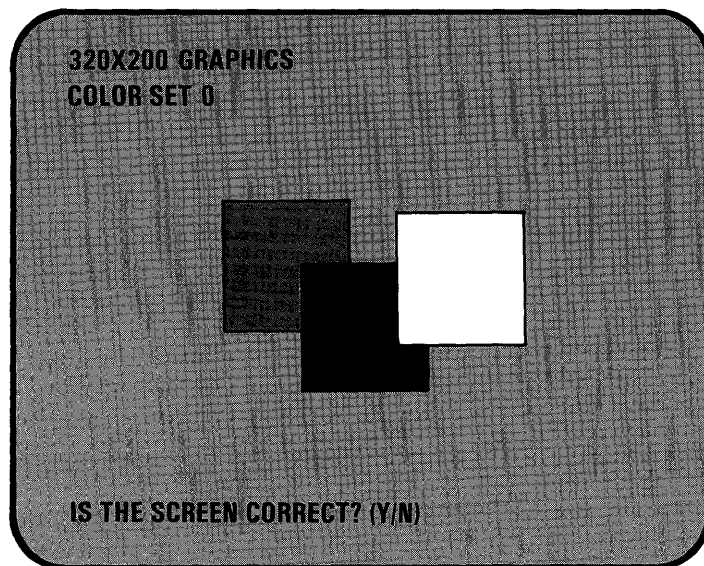

YES – Press **Y**; then press the **Enter** key. Continue with the next step.

NO – Press **N**; then press the **Enter** key. Record the error message, and have the unit that contains the adapter serviced.

Test 2400 - Enhanced Graphics Adapter *(continued)*

12. Did the following appear on your screen, and are the colors correct?

Note: Text in illustration is black for clarity.

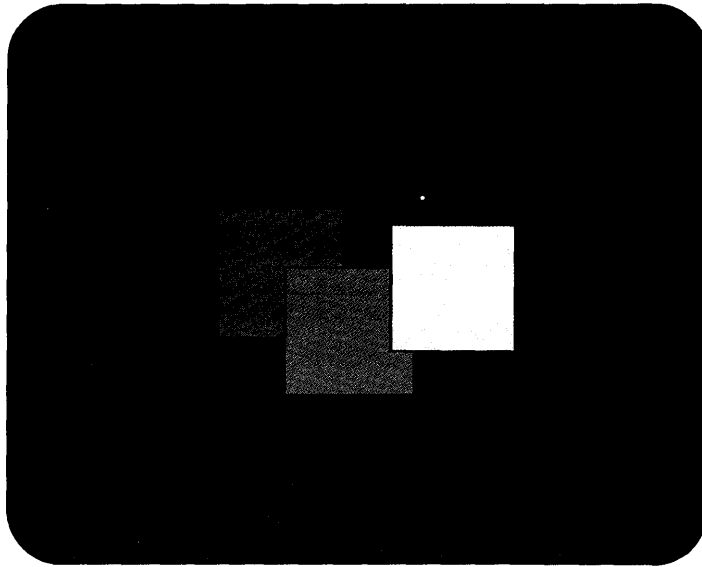

YES – Press **Y**, then press the **Enter** key. Continue with the next step.

NO – Press **N**, then press the **Enter** key. Record the error message and have the unit that contains the adapter serviced.

Problem Determination Procedures

Test 2400 - Enhanced Graphics Adapter *(continued)*

13. Did the following appear on your screen?

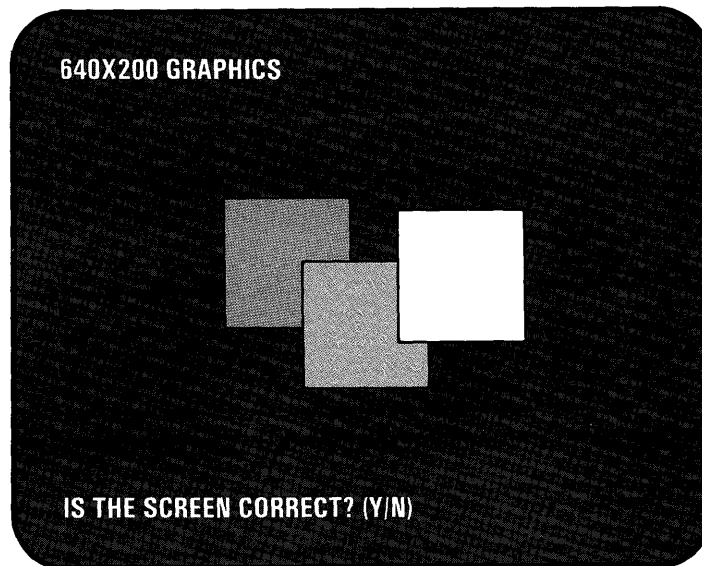

YES – Press **Y**, then press the **Enter** key. Continue with the next step.

NO – Press **N**; then press the **Enter** key. Record the error message, and have the unit that contains the adapter serviced.

Test 2400 - Enhanced Graphics Adapter (continued)

14. Did the following appear on your screen, and are the colors correct?

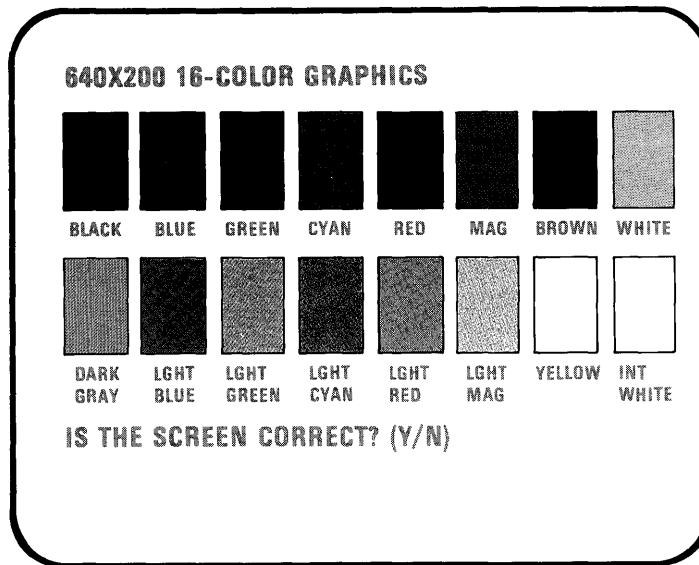

YES – Press **Y**, then press the **Enter** key. Continue with the next step.

NO – Press **N**; then press the **Enter** key. Record the error message, and have the unit that contains the adapter serviced.

Problem Determination Procedures

Test 2400 - Enhanced Graphics Adapter (*continued*)

15. The following will appear if you have only 64Kb of memory on your Enhanced Graphics Adapter.

Did the following appear on your screen?

NO – Continue with the the next step.

YES – Is the screen as shown below and are the colors correct?

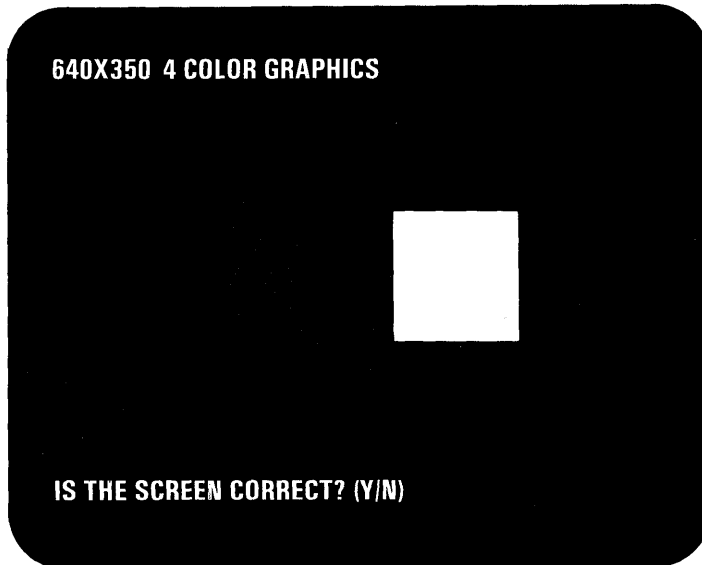

YES – Press **Y**, then press the **Enter** key. Continue with the next step.

NO – Press **N**; then press the **Enter** key. Record the error message, and have the unit that contains the adapter serviced.

Test 2400 - Enhanced Graphics Adapter *(continued)*

16. The following will appear if you have 128 or more Kb of memory on your Enhanced Graphics Adapter.

Did the following appear on your screen?

NO – Continue with the the next step.

YES – Is the screen as shown below and are the colors correct?

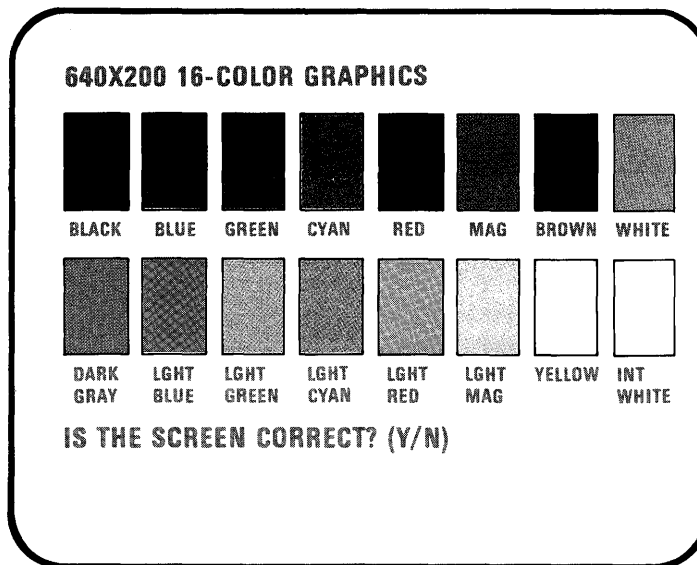

YES – Press **Y**, then press the **Enter** key. Continue with the the next step.

NO – Press **N**; then press the **Enter** key. Record the error message, and have the unit that contains the adapter serviced.

Problem Determination Procedures

Test 2400 - Enhanced Graphics Adapter (*continued*)

17. Did the following appear on your screen?

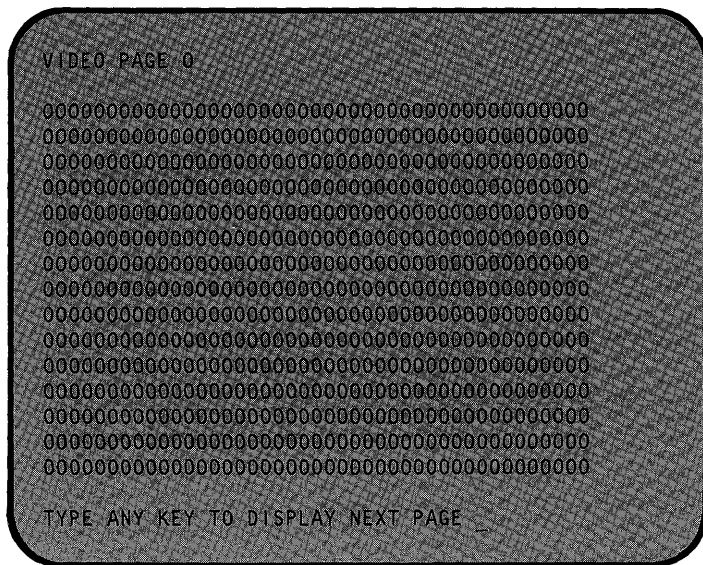

- YES** – Go to the next step.

- NO** – Press **N**; then press the **Enter** key. Record the error message, and have the unit that contains the adapter serviced.

Test 2400 - Enhanced Graphics Adapter *(continued)*

18. There are eight video pages. Press any key. VIDEO PAGE 1 appears. Continue to press any key until VIDEO PAGE 0 appears.
19. Did all eight pages appear?

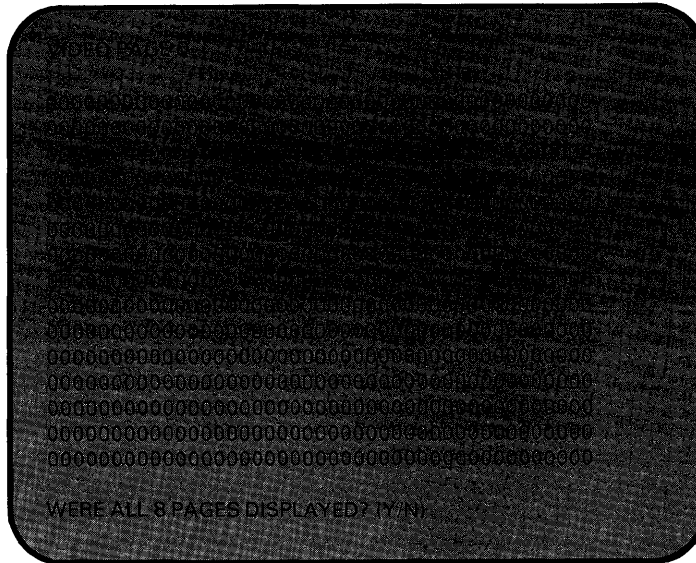

YES – Press **Y**; then press the **Enter** key. Your system has completed this test successfully. Continue with the next test.

NO – Press **N**; then press the **Enter** key. Record the error message, and have the unit that contains the adapter serviced.

Problem Determination Procedures

Test 2400 - Enhanced Graphics Adapter (*continued*)

20. Refer to Appendix A to determine the mode of operation you are in.

Are you in the *Color* mode?

NO – Go to step 32.

YES – Did the following appear on your screen (ignore color problems)?

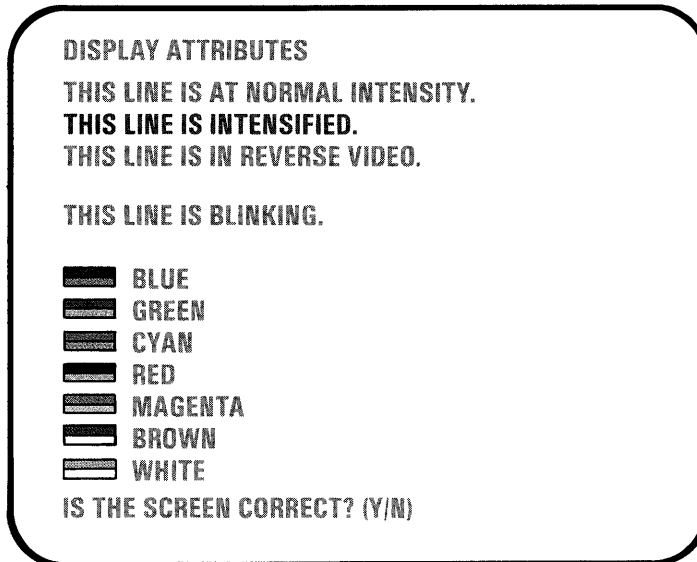

YES – Go to the next step.

NO – Press **N**; then press the **Enter** key. Record the error message, and have the unit that contains the adapter serviced.

Test 2400 - Enhanced Graphics Adapter *(continued)*

21. Examine the DISPLAY ATTRIBUTES screen. Are the colors correct?

Note: There should be two different shades of each color.

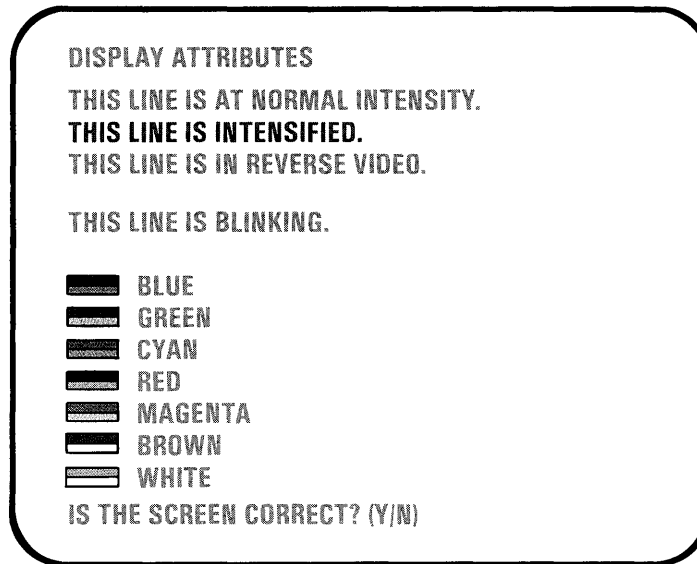

YES – Press **Y**; then the **Enter** key. Continue with the next step.

NO – Have the display serviced.

Problem Determination Procedures

Test 2400 - Enhanced Graphics Adapter (continued)

22. Did the following appear on your screen?

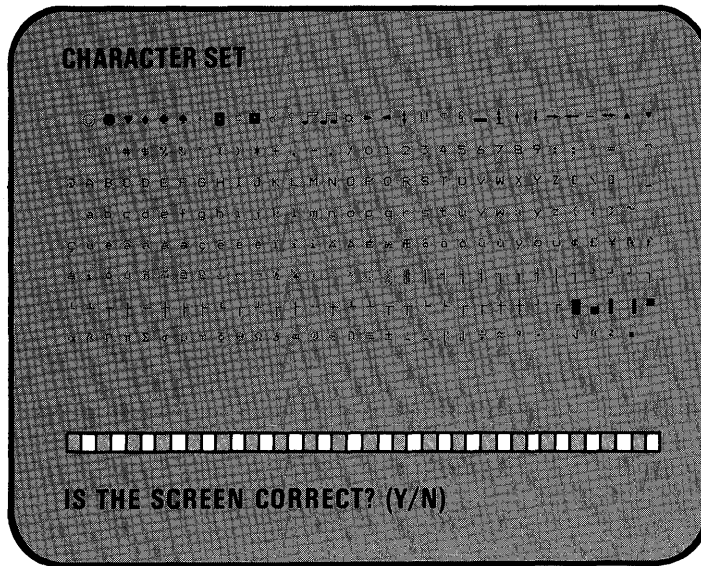

YES – Press **Y**; then the **Enter** key. Continue with the next step.

NO – Press **N**; then the **Enter** key. Record the error message and have the unit that contains the adapter serviced.

Test 2400 - Enhanced Graphics Adapter *(continued)*

23. Did the following appear on your screen?

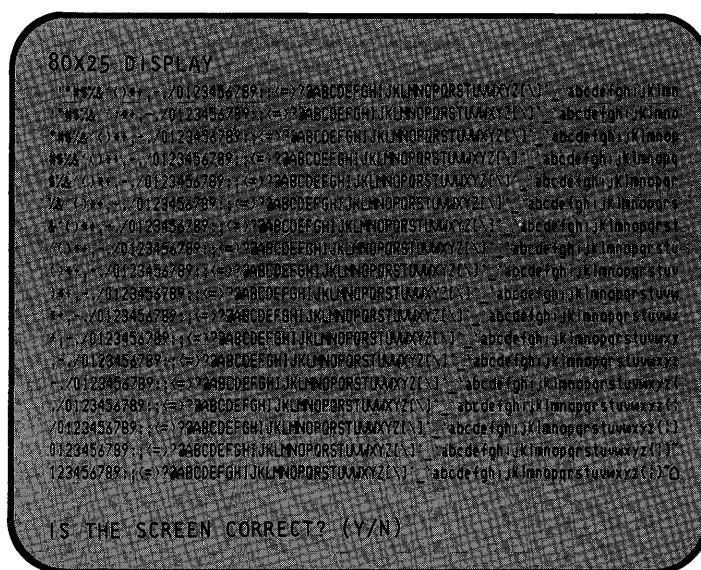

YES – Press **Y**; then the **Enter** key. Continue with the next step.

NO – Press **N**; then the **Enter** key. Record the error message and have the unit that contains the adapter serviced.

Problem Determination Procedures

Test 2400 - Enhanced Graphics Adapter (continued)

24. Did the following appear on your screen?

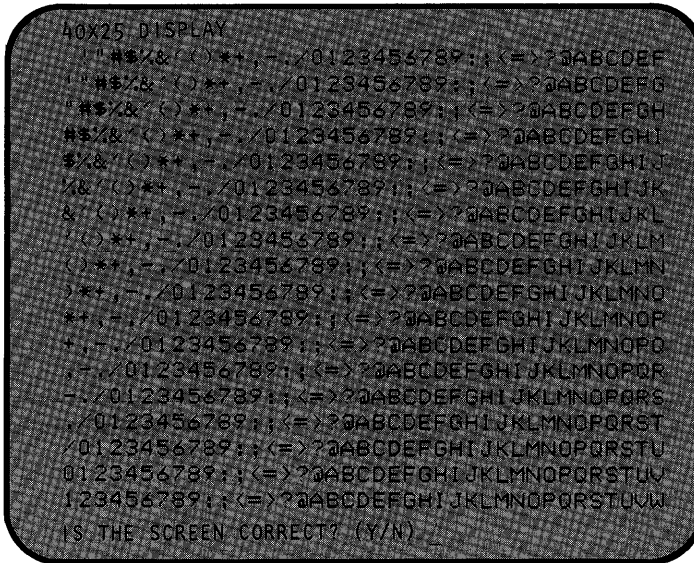

YES – Press **Y**; then the **Enter** key. Continue with the next step.

NO – Press **N**; then the **Enter** key. Record the error message and have the unit that contains the adapter serviced.

Test 2400 - Enhanced Graphics Adapter *(continued)*

25. Did the following appear on your screen and are the colors correct?

Note: Text in illustration is black for clarity.

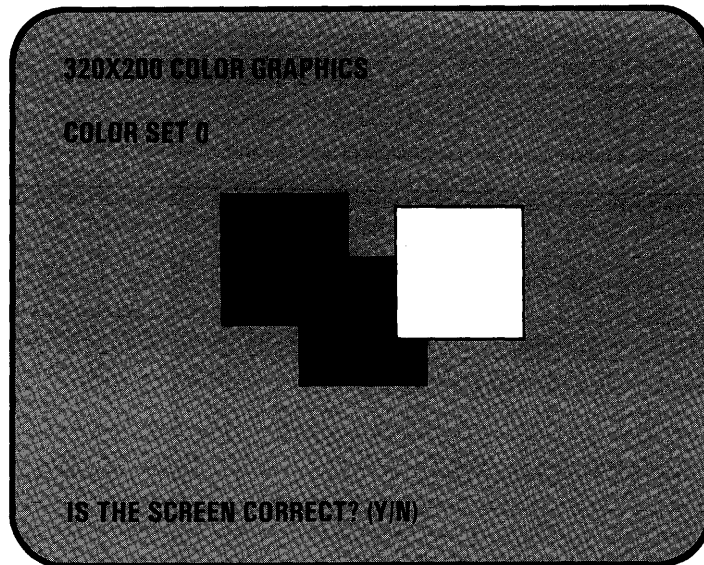

YES – Press **Y**; then the **Enter** key. Continue with the next step.

NO – Press **N**; then the **Enter** key. Record the error message and have the unit that contains the adapter serviced.

Problem Determination Procedures

Test 2400 - Enhanced Graphics Adapter *(continued)*

26. Did the following appear on your screen, and are the colors correct?

Note: Text in illustration is black for clarity.

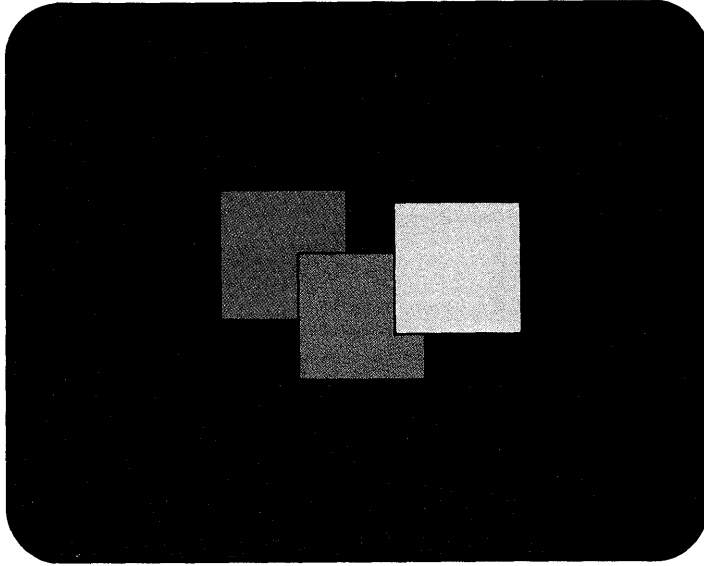

YES – Press **Y**; then the **Enter** key. Continue with the next step.

NO – Press **N**; then the **Enter** key. Record the error message and have the unit that contains the adapter serviced.

Test 2400 - Enhanced Graphics Adapter *(continued)*

27. Did the following appear on your screen?

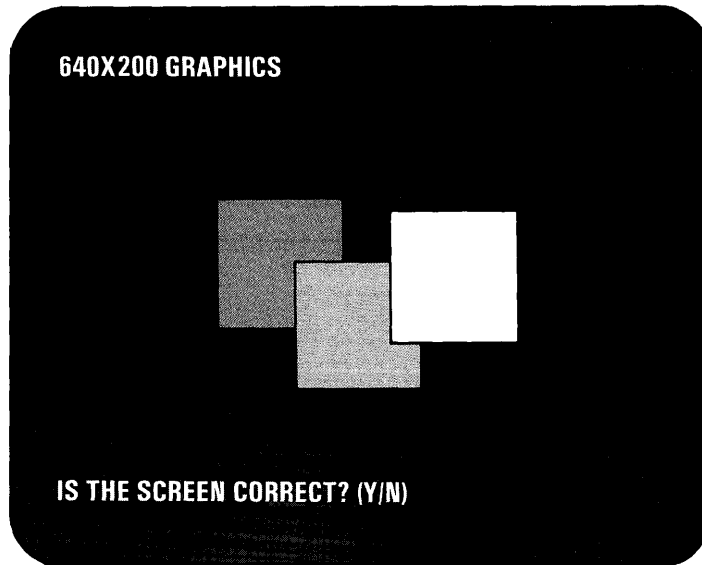

YES – Press **Y**; then the **Enter** key. Continue with the next step.

NO – Press **N**; then the **Enter** key. Record the error message and have the unit that contains the adapter serviced.

Problem Determination Procedures

Test 2400 - Enhanced Graphics Adapter (continued)

28. Did the following appear on your screen, and are the colors correct?

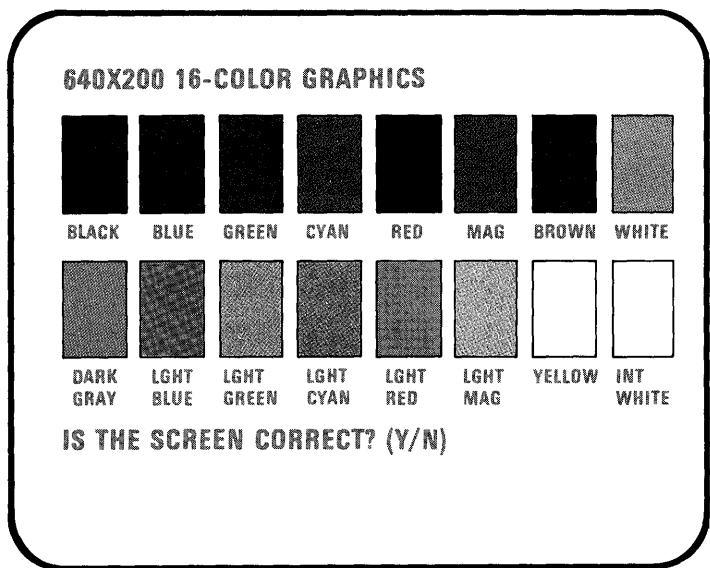

YES – Press **Y**; then the **Enter** key. Continue with the next step.

NO – Press **N**; then the **Enter** key. Record the error message and have the unit that contains the adapter serviced.

Test 2400 - Enhanced Graphics Adapter *(continued)*

29. Did the following appear on your screen?

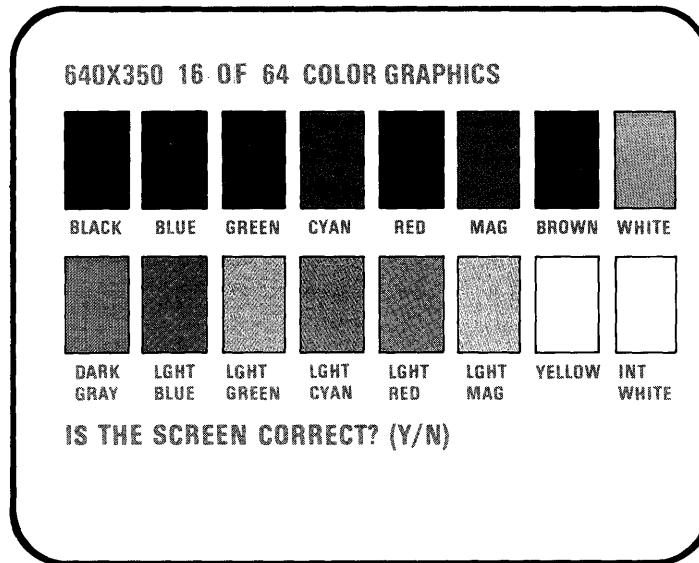

YES – Go to the next step.

NO – Press **N**; then the **Enter** key. Record the error message and have the unit that contains the adapter serviced.

Problem Determination Procedures

Test 2400 - Enhanced Graphics Adapter *(continued)*

30. There are eight video pages. Press any key; VIDEO PAGE 1 appears. Continue to press any key until VIDEO PAGE 0 appears again.
31. Did all eight pages appear?

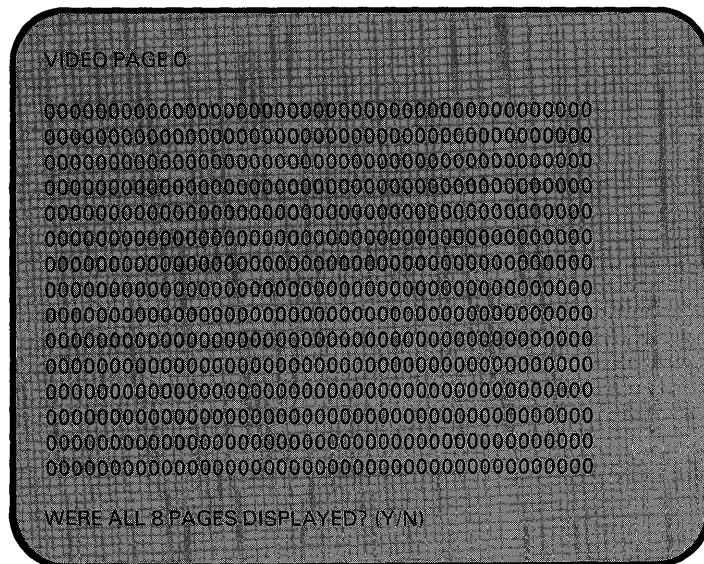

- YES** – Press **Y**; then press the **Enter** key. Your system has completed this test successfully. Continue with the next test.
- NO** – Press **N**; then the **Enter** key. Record the error message and have the unit that contains the adapter serviced.

Test 2400 - Enhanced Graphics Adapter *(continued)*

32. Refer to Appendix A to determine the mode of operation you are using.

Are you operating in the *Monochrome* mode?

NO – Continue with the next test.

YES – Did the following appear on your screen?

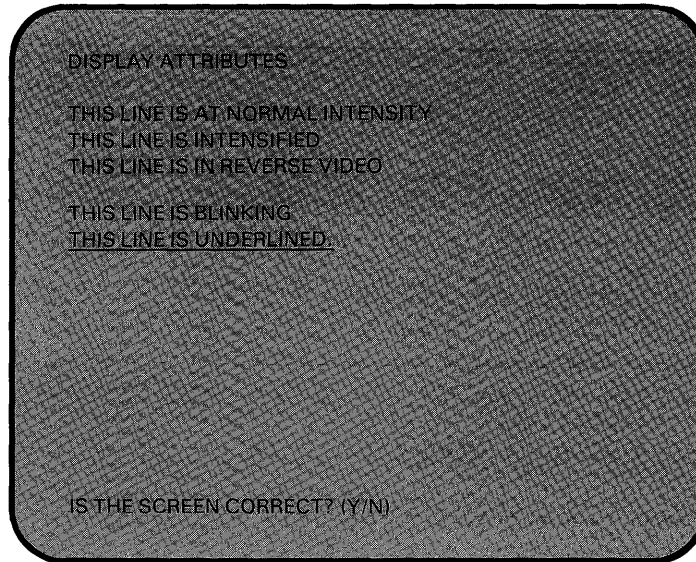

YES – Press **Y**; then press the **Enter** key. Continue with the next step.

NO – Press **N**; then the **Enter** key. Record the error message and have the unit that contains the adapter serviced.

Problem Determination Procedures

Test 2400 - Enhanced Graphics Adapter *(continued)*

33. Did the following appear on your screen?

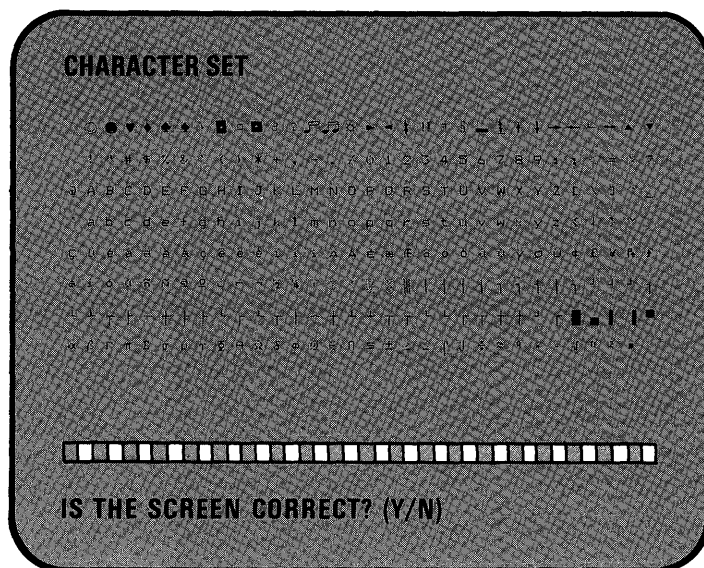

YES – Press **Y**; then press the **Enter** key. Continue with the next step.

NO – Press **N**; then the **Enter** key. Record the error message and have the unit that contains the adapter serviced.

Test 2400 - Enhanced Graphics Adapter (continued)

34. Did the following appear on your screen?

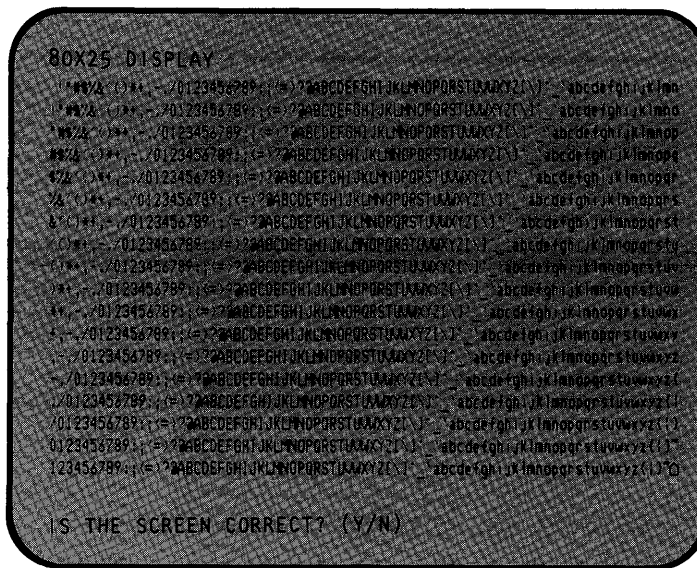

YES – Press **Y**; then press the **Enter** key. Continue with the next step.

NO – Press **N**; then the **Enter** key. Record the error message and have the unit that contains the adapter serviced.

Problem Determination Procedures

Test 2400 - Enhanced Graphics Adapter *(continued)*

35. Did the following appear on your screen?

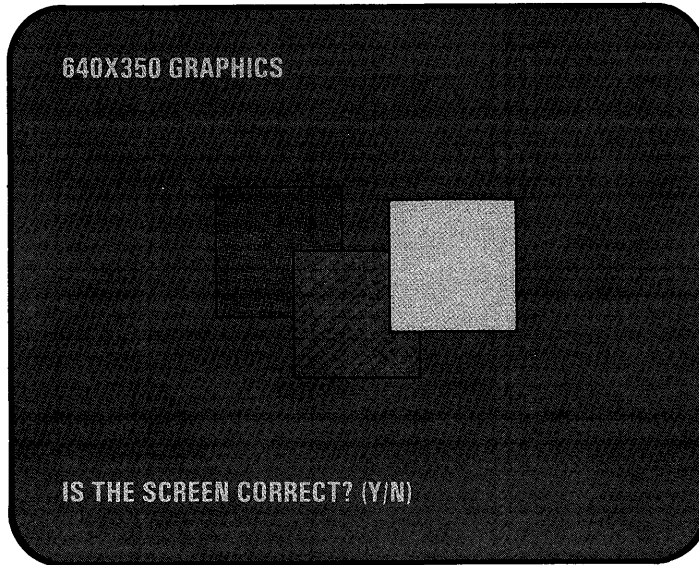

Note: The right block should be blinking.

YES – Press **Y**; then press the **Enter** key. Continue with the next step.

NO – Press **N**; then the **Enter** key. Record the error message and have the unit that contains the adapter serviced.

Test 2400 - Enhanced Graphics Adapter *(continued)*

36. Did the following appear on your screen?

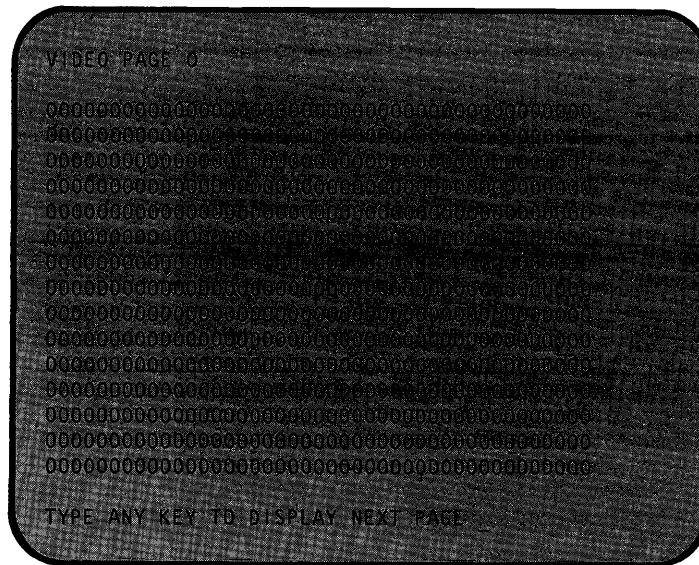

YES – Go to the next step.

NO – Press **N**; then the **Enter** key. Record the error message and have the unit that contains the adapter serviced.

Problem Determination Procedures

Test 2400 - Enhanced Graphics Adapter *(continued)*

37. There will be four or eight video pages, depending on the amount of graphics memory installed. Press any key; VIDEO PAGE 1 appears. Continue to press any key until VIDEO PAGE 0 appears.

38. Did all the pages appear?

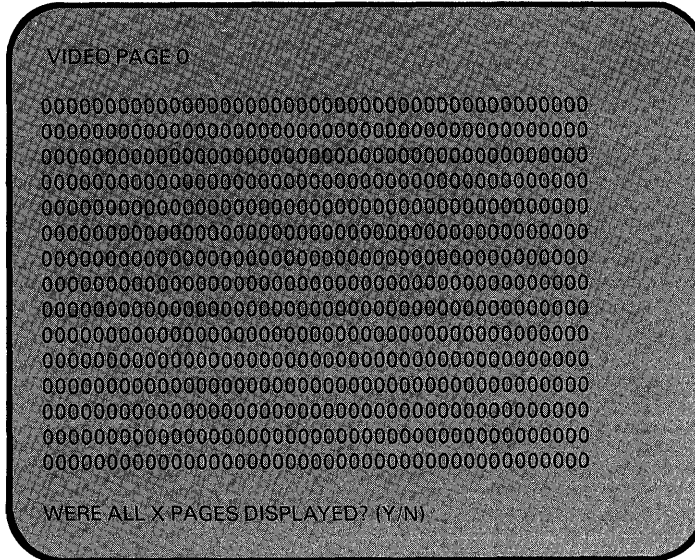

Note: The X will be either 4 or 8, depending on the amount of graphics memory installed.

YES – Press **Y**; then press the **Enter** key. Your system has completed this test successfully. Continue with the next test.

NO – Press **N**; then the **Enter** key. Record the error message and have the unit that contains the adapter serviced.

Test 3600 - General Purpose Interface Bus Adapter

1. Do you have an IBM General Purpose Interface Bus Adapter installed in your system?

NO – Continue with the next test.

YES – Did the following appear on your screen?

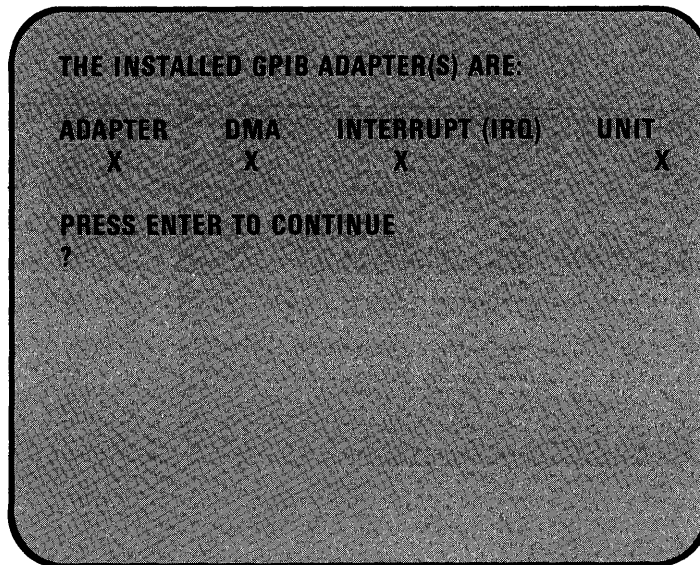

YES – Continue with the next step.

NO – Have the unit that contains the failing IBM General Purpose Interface Bus Adapter serviced.

Problem Determination Procedures

Test 3600 - General Purpose Interface Bus Adapter *(continued)*

2. The following appears for each IBM General Purpose Interface Bus Adapter installed in your system.

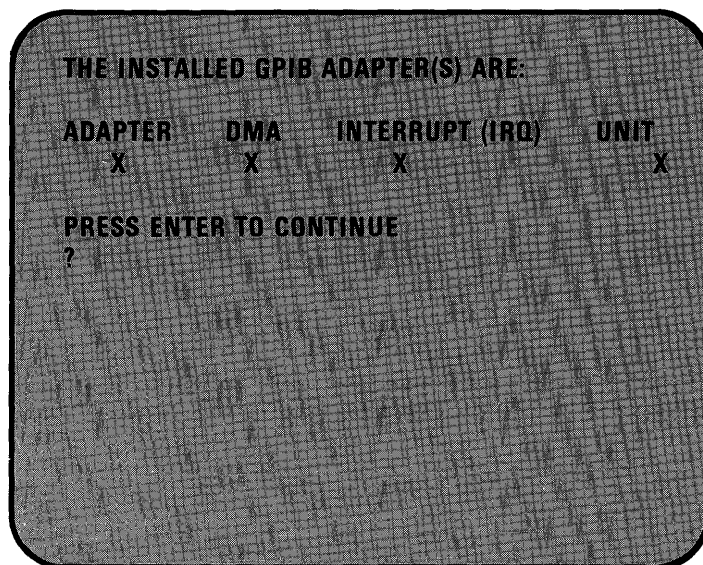

Continue with the next step.

Test 3600 - General Purpose Interface Bus Adapter *(continued)*

3. Does the information on your screen match the information recorded below?

Note: If the information in the following table has not been filled in, refer to Appendix A, "Option List" and verify the information is correct.

Adapter	DMA	Interrupt	Unit
0	_____	_____	_____
1	_____	_____	_____
2	_____	_____	_____
3	_____	_____	_____
4	_____	_____	_____
5	_____	_____	_____
6	_____	_____	_____
7	_____	_____	_____

YES – Continue with the next step.

NO – Check that all jumpers have been set correctly. Have the unit that contains the failing IBM General Purpose Interface Bus Adapter serviced.

Problem Determination Procedures

Test 3600 - General Purpose Interface Bus Adapter *(continued)*

4. Press the **Enter** key.
5. Disconnect all cables connected to each IBM General Purpose Interface Bus Adapter.

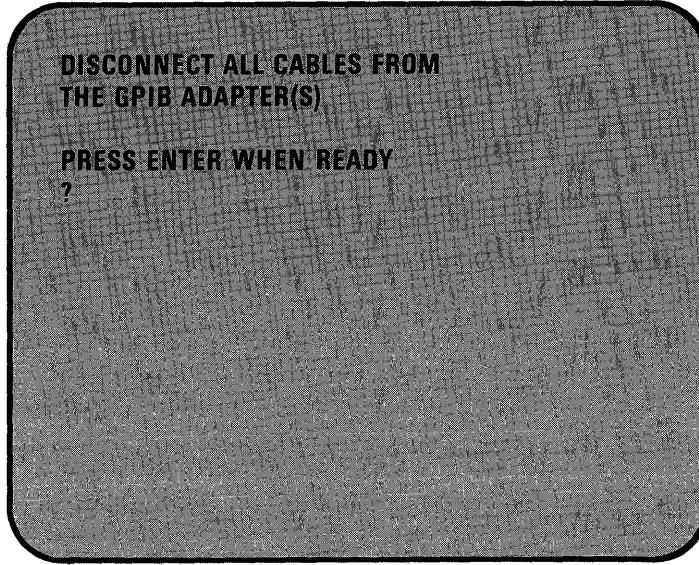

Continue with the next step.

Test 3600 - General Purpose Interface Bus Adapter *(continued)*

6. Press the **Enter** key.

7. Did an error message appear on your screen?

YES – Record the error message and have the unit that contains the failing IBM General Purpose Interface Bus Adapter serviced.

NO – Your system has completed this test successfully.

Connect any cables you disconnected.

Continue with the next test.

This page is intentionally left blank.

Test 3800 - Data Acquisition and Control Adapter

1. Do you have an IBM Data Acquisition and Control Adapter installed in your system?

NO – Continue with the next test.

YES – Did the following error message appear on your screen?

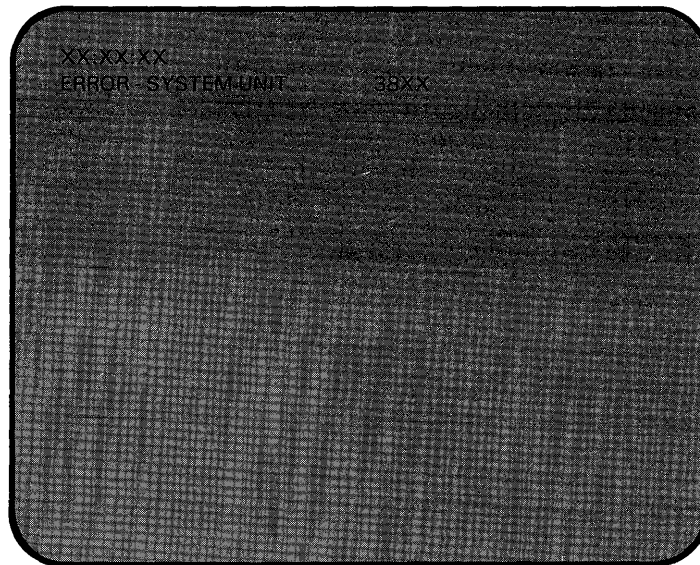

YES – Have the system unit serviced.

NO – Continue with the next step.

Problem Determination Procedures

Test 3800 - Data Acquisition and Control Adapter *(continued)*

2. Did the following message appear on your screen?

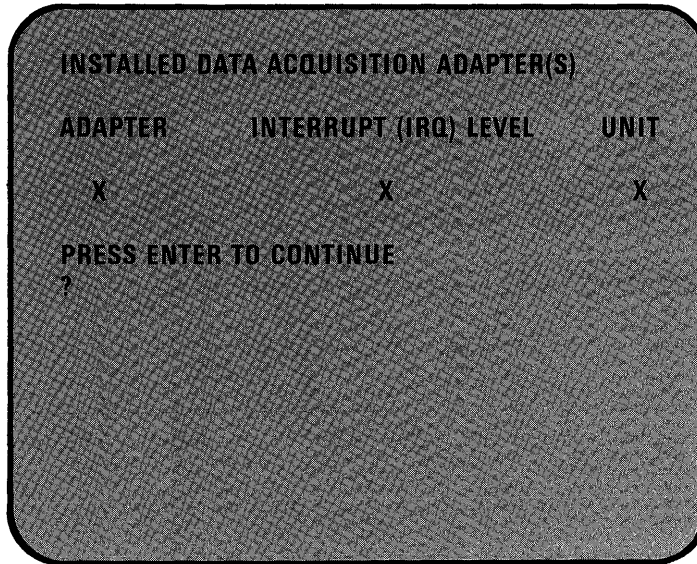

Note: Refer to Appendix A, “Option List” to verify information is correct for options installed.

YES – Continue with the next step.

NO – Have the system unit serviced.

Test 3800 - Data Acquisition and Control Adapter *(continued)*

3. Press the **Enter** key. Did the following message appear on your screen?

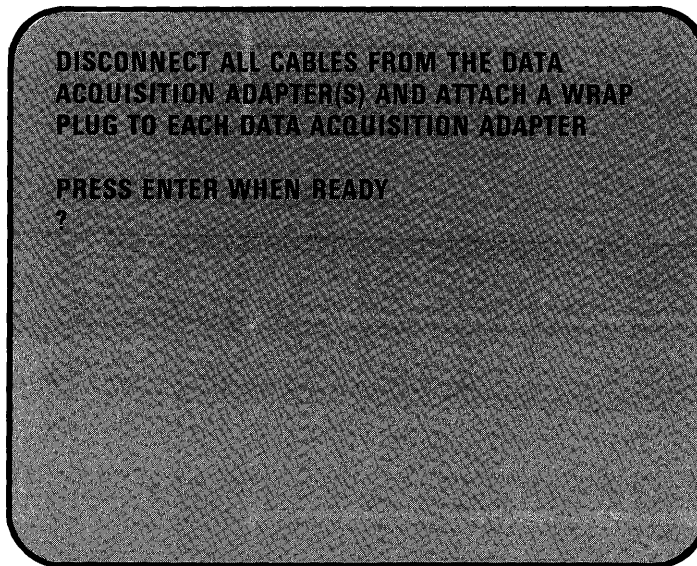

Note: Refer to the following figure. Install a wrap plug on each installed IBM Data Acquisition and Control Adapter.

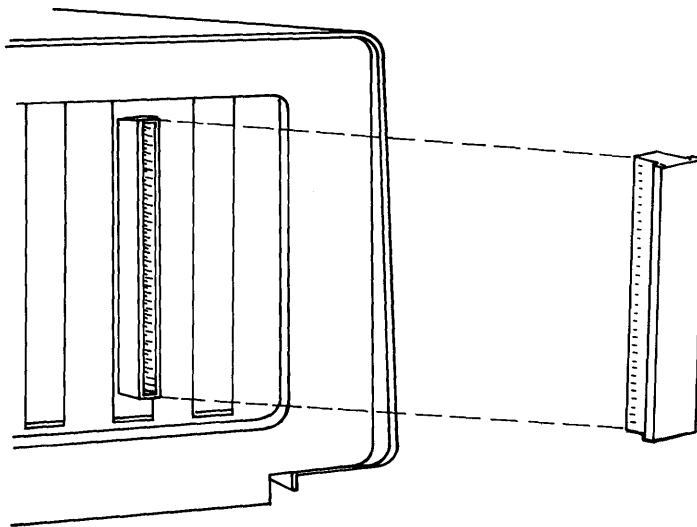

- YES** – Follow the screen instructions and continue with the next step.
- NO** – Have the system unit serviced.

Problem Determination Procedures

Test 3800 - Data Acquisition and Control Adapter *(continued)*

4. Did the following message appear on your screen?

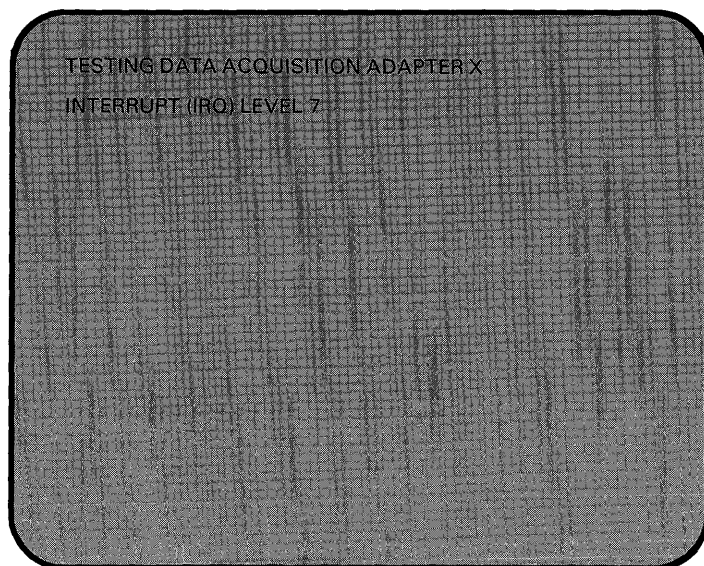

YES – Continue with the next step.

NO – Have the system unit serviced.

Test 3800 - Data Acquisition and Control Adapter *(continued)*

5. Did the following error message appear on your screen?

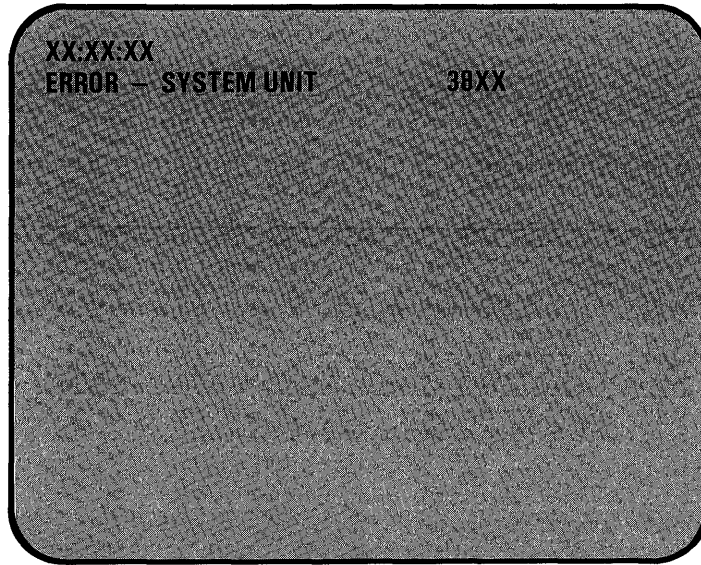

YES – Have the system unit serviced.

NO – The system has completed this test successfully. Continue with the next test.

This page is intentionally left blank.

Test 4700 - Realtime Clock

Did the following error message appear on your screen?

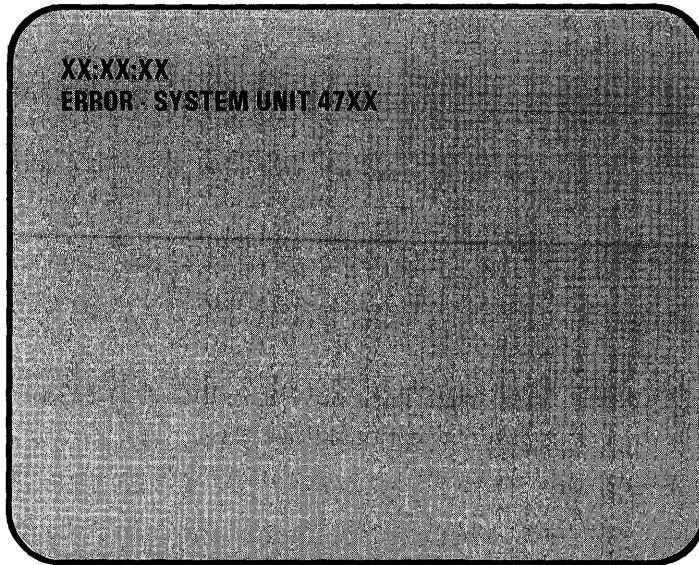

YES – Have the system unit serviced.

NO – The system unit has completed this test successfully.

Note: If you have a printer attached, go to Test 1400. If you have an IBM Industrial Color Display attached, go to Test 9000. If you do not have a printer or an IBM Industrial Color Display attached, you have finished the problem determination procedures with no failures. Remove the scratch diskette from the diskette drive. Return the *Diagnostics* diskette to the back of this manual. Now you can load the operating system.

If you have any other problems, contact your place of purchase.

This page is intentionally left blank.

Test 9000 - IBM Industrial Color Display

Note: If your IBM Industrial Color Display requires service, the power cord must be returned with the display. Before returning your display for service, remove all accessories (such as an optional screen filter), if any.

1. Set the display's Power control to On.
2. Is the display Power-on indicator lit?
YES – Continue with the next step.
NO – Check that the power cord is plugged in a functioning outlet and in the rear of the display. If it is, have the display serviced.
3. Set the system unit's Power switch to Off.
4. Turn the controls on your display to the maximum brightness and contrast. If necessary, refer to the manual that came with the display for more information.
5. Look at the back of the display; turn the left (vertical-size) control to the minimum.

Black areas should appear on the screen as shown in the following examples.

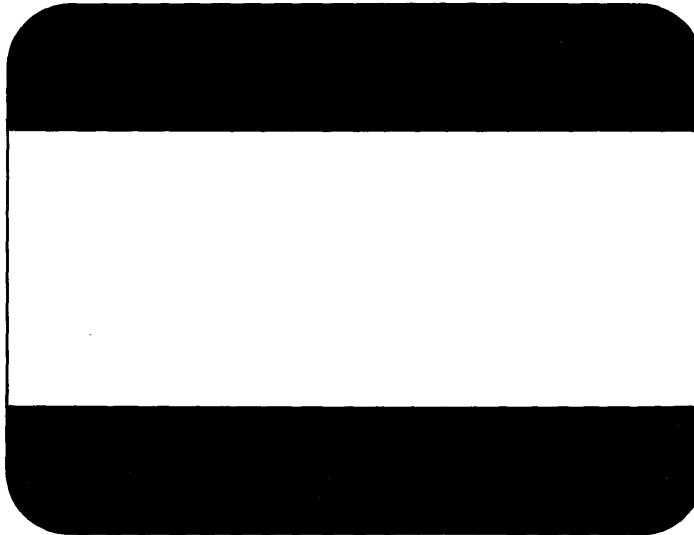

Typical 5532 display

Problem Determination Procedures

Test 9000 - IBM Industrial Color Display *(continued)*

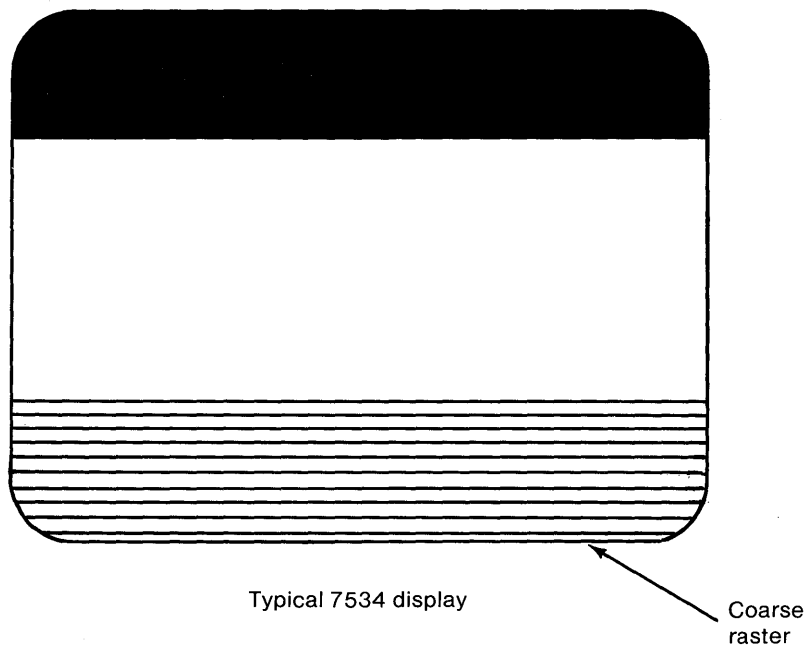

6. Does the screen look like one of the illustrations above?

YES – For 5532 display, continue with step 7.
For 7534 Display continue with step 8.

NO – Have the display serviced.

7. Are the black areas approximately the same size?

Note: Answer this question **NO** only if one area is less than half the width of the other.

YES – Continue with the next step.

NO – Have the display serviced.

8. 7534 Display:

Turn the left (vertical size 1) control until the black area just disappears.

5532 Display:

Turn the left (vertical size) control until the black areas just disappear. If one of the black areas disappears before the other, continue to turn the control until the second black area is gone.

9. Is the entire screen white?

YES – Go to Step 14.

NO – Continue with the next step.

Test 9000 - IBM Industrial Color Display *(continued)*

10. Set the display's Power control to Off.
11. Disconnect the display's signal cable from the system unit.
12. Set the display's Power control to On.
13. Is the screen white?
 - YES** – Have the system unit serviced.
 - NO** – Have the display serviced.
14. Open the load levers on all diskette drives.
15. Watch the screen and set the system unit's Power switch to On.
16. Did the screen change from white to black when the system unit's Power switch was set to On? (The screen may remain black for only 13 seconds before changing again.)
 - YES** – Continue with the next step.
 - NO** – Have the display serviced.
17. Wait for the power-on self-test (POST) to finish. The IBM Personal Computer Basic message, with a blinking cursor, appears unless an operating system is automatically loaded from a fixed disk drive.
18. Is your screen blank?
 - YES** – Have the system unit serviced.
 - NO** – Continue with the next step.
19. Is the screen rolling?
 - YES** – Continue with the next step.
 - NO** – Go to Step 23.
20. Do you have an IBM 5532 Industrial Color Display?
 - YES** – Continue with the next step.
 - NO** – Have the display serviced.
21. Turn the vertical-hold control until the screen stops rolling.

Problem Determination Procedures

Test 9000 - IBM Industrial Color Display (*continued*)

22. Were you able to make the screen stop rolling?
 - YES** – Continue with the next step.
 - NO** – Have the display serviced.
23. Does the screen have white characters on a dark background?
 - YES** – Go to Step 29.
 - NO** – Continue with the next step.
24. Set the system unit's Power switch to Off.
25. Set the display's Power control to Off.
26. Disconnect the display's signal cable from the system unit.
27. Set the display's Power control to On.
28. Is the screen white?
 - YES** – Have the system unit serviced.
 - NO** – Have the display serviced.
29. BASIC is needed for the following steps. Is the BASIC message on the screen?
 - YES** – Go to Step 32.
 - NO** – Continue with the next step.
30. An operating system loaded from the fixed disk when you set the system unit's Power to On. When the **C>** appears on the screen, type **BASIC** and press the **Enter** key.
31. Did BASIC load?
 - YES** – Continue with the next step.
 - NO** – Determine why BASIC does not load. After loading BASIC, continue with the next step.
32. Type **SCREEN 1** and press the **Enter** key.
33. Type **COLOR 7, 0** and press the **Enter** key.
34. Type **CLS** and press the **Enter** key.
35. Move the brightness control from limit to limit.

Test 9000 - IBM Industrial Color Display (continued)

36. Does the intensity of the screen presentation change?

YES – Continue with the next step.

NO – Have the display serviced.

37. Increase the brightness and move the contrast control from limit to limit.

38. Does the intensity of the screen presentation change?

YES – Continue with the next step.

NO – Have the display serviced.

39. Increase the contrast on the display. Can you find your problem in the following examples?

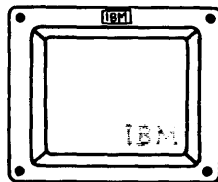

Too dim

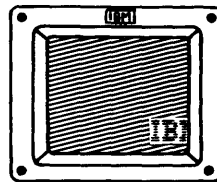

Too wide

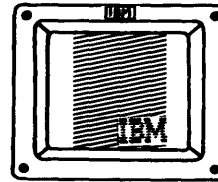

Too narrow

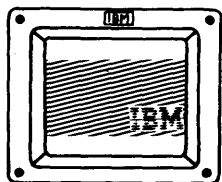

Too short

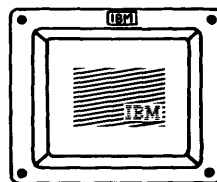

Shrunk

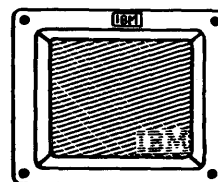

Out of focus

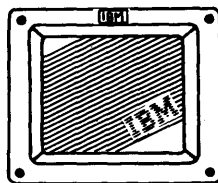

Tilted

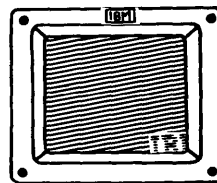

Changes size when
brightness control
turned

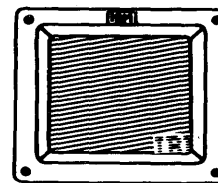

Characters shifted left
or right or up and
down off the display
area

YES – Have your display serviced.

NO – Continue with “Vertical-Size Adjustment” on the next page.

Problem Determination Procedures

Test 9000 - IBM Industrial Color Display (*continued*)

Vertical-Size Adjustment

1. Did you come directly from Step 39 of the previous section?
YES – Go to Step 10.
NO – Continue with the next step.
2. Did you come here directly for a vertical-size adjustment?
YES – Continue with the next step.
NO – You should not be here. Return to the last step that sent you to this test.
3. BASIC is needed for the following steps.
 - a. Open the load lever(s) on your diskette drive(s).
 - b. Set the system unit's Power switch to Off.
 - c. Wait 10 seconds and set the Power switch to On.
4. After some delay, does the IBM Personal Computer BASIC message appear on the screen?
YES – Go to Step 7.
NO – Continue with the next step.
5. An operating system must have loaded from a fixed disk. When the **C>** appears on the screen, type **BASIC** and press the **Enter** key.
6. Did BASIC load?
YES – Continue with the next step.
NO – Determine why BASIC does not load. After loading BASIC, continue with the next step.
7. Type **SCREEN 1** and press the **Enter** key.
8. Type **COLOR 7, 0** and press the **Enter** key.
9. Type **CLS** and press the **Enter** key.
10. **OK** should appear in the upper-left corner of the screen. Adjust the left vertical control so the O in OK is an equal distance from the left edge and the top edge of the screen.

Test 9000 - IBM Industrial Color Display *(continued)*

11. Were you able to make the adjustment?

YES – Continue with the next step.

NO – Have your display serviced if turning the left control does not change the vertical position of the screen.

12. Is your display an IBM 5532 Industrial Color Display?

YES – Continue with the next step.

NO – Go to Step 19.

13. Type **SCREEN 0** and press the **Enter** key.

14. Type **COLOR 0, 7** and press the **Enter** key.

15. Type **CLS** and press **Enter** key.

16. The screen is now white with a black border.

17. Are the black borders on the left and right about the same?

Note: Answer this question with **NO** only if you see a significant difference in width.

YES – Continue with the next step.

NO – Have your display serviced.

18. This concludes the manual test of your IBM 5532 Industrial Color Display.

If you performed TEST 9000 because of a problem, return to the step that sent you to this test, unless you corrected the problem with one of the adjustments.

If you performed a vertical-size adjustment only, this adjustment is completed.

19. Is your display an IBM 7534 Industrial Color Display?

YES – Continue with the next step.

NO – Your display is not supported by this test.

20. Type **SCREEN 0** and press the **Enter** key.

21. Type **COLOR 0, 7** and press the **Enter** key.

22. Type **CLS** and press the **Enter** key.

23. The screen is now white with a black border.

Problem Determination Procedures

Test 9000 - IBM Industrial Color Display (*continued*)

24. Turn the right (vertical-size 2) control from limit to limit.
25. Does the screen move?
- YES** – Continue with the next step.
 - NO** – Go to Step 30.
26. Are the black borders on the left and right of the screen about equal in width?
- Note:** Answer this question with **NO** only if you see a significant difference in width.
- YES** – Continue with the next step.
 - NO** – Have your display serviced.
27. Adjust the right (vertical-size 2) control until the black border on top is about the same width as the border on the left.
28. Were you able to make the adjustment?
- YES** – Continue with the next step.
 - NO** – Have your display serviced if turning the right control does not change the vertical position of the screen.
29. This concludes the manual test for your IBM 7534 Industrial Color Display.
- If you performed Test 9000 because of a problem, return to the step that sent you to this test, unless you corrected the problem with one of the adjustments.
- If you performed a vertical-size adjustment only, this adjustment is completed.
30. Is your IBM 7534 Industrial Color Display attached to an Enhanced Graphics Adapter (EGA)?
- Note:** Refer to the “Option List” that came with your computer for the required information.
- YES** – Continue with the next step.
 - NO** – Go to Step 34.
31. If you have problems with vertical size in high-resolution mode, load the program that contains the problem screen. Advance the program to a point where that screen is displayed.

Test 9000 - IBM Industrial Color Display *(continued)*

32. Turn the right (vertical-size 2) control until the screen is adjusted to your satisfaction.

33. Were you able to make the adjustment?

YES – Go to Step 29.

NO – Have your display serviced.

34. Your IBM 7534 Industrial Color Display is attached to a Color Monitor Adapter (CGA). High-resolution is not possible in this mode. The right (vertical-size 2) control does not work.

If you performed Test 9000 because of a problem, return to the step that sent you to this test, unless you corrected the problem with one of the adjustments.

If you performed a vertical-size adjustment only, this adjustment is completed.

Chapter 1. Installing the Keyboard

This manual tells you how to:

- Cable the keyboard
- Locate the *Keyboard Utility* diskette
- Update DOS.

Installing the Keyboard

Cabling the IBM Industrial Computer Keyboard

Perform the following steps to cable the keyboard:

1. Set the system unit's Power switch to Off.
2. Set the Power switches for all attached options to Off.
3. Connect the 6-pin connector on the keyboard cable to the rear of the keyboard.

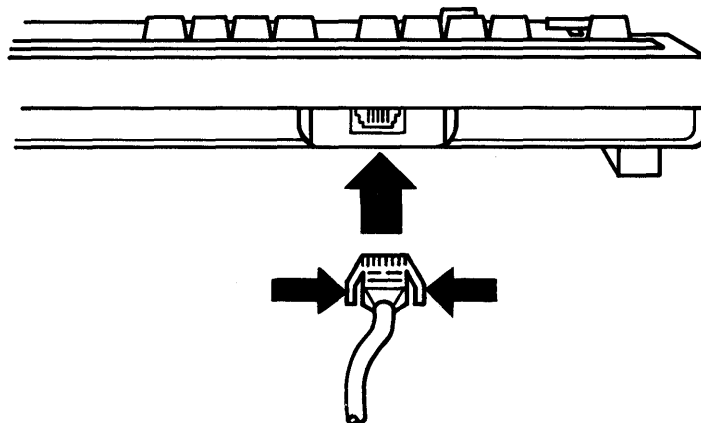

Note: To remove the keyboard cable, press the clips in on the side of the 6-pin connector. Then remove the cable.

4. Connect the other end of the cable to the system unit.

Updating DOS Using the Keyboard Utility Diskette

Locating the Keyboard Utility Diskette

The *Keyboard Utility* diskette is located in the *Operator's Guide* that came with your industrial computer.

Updating DOS

Note: You must have a display attached to your system unit to complete the following procedure.

Because the IBM Industrial Computer Keyboard has more keys than a standard keyboard, you must update DOS on your system. When you update DOS, you are adding a program that allows the system to recognize the additional keys.

Follow the procedure below to add the program to your DOS diskette or fixed disk drive. You should also use this procedure to update any backup DOS diskettes. Perform the procedure only once for each diskette.

Updating Procedure

Perform the following steps to update a diskette or a fixed disk drive:

1. Set the system unit's Power switch to Off.
2. Set the Power switches for all external devices to Off.
3. Insert your DOS (3.0) diskette in drive A.
4. Set the Power switches for all external devices to On.
5. Set the system unit's Power switch to On.
6. When the DOS prompt appears on the screen, remove the DOS diskette and replace it with the *Keyboard Utility* diskette.
7. Type **AUTOEXEC.** and press the **Enter** key.
8. Follow the instructions on the screen to update DOS.
9. When you have completed all the instructions, the DOS prompt should appear on the screen.

Appendix A. Option List

Note: When the Problem Determination Procedures ask you to refer to Appendix A to determine the “mode of operation,” refer to this Option List to identify the options installed in your system and the type of display (monochrome, color, or enhanced color).

IMPORTANT: Check those items shown below that are installed in your system. For installed options not shown, record the name and memory sizes under :

Diskette Drives

320/360Kb (Double-Sided)
 320/360Kb (Double-Sided) Optional

Fixed Disk Drive

10Mb Optional

Base Memory

128Kb 192Kb 256Kb

Display

Monochrome Color Enhanced Color

Other Options

Use the space below and on the following page to record the name, and, if applicable, other variable parameters of other options installed in your system.

Appendix A. Option List

Adapter	DMA	Interrupt	Unit	SLOT
0	_____	_____	_____	1 EGA
1	_____	_____	_____	2 3278/9 Emulator
2	_____	_____	_____	3 64/256 memory Expansion
3	_____	_____	_____	4 FORTEGRAPHICS 536
4	_____	_____	_____	5 Fixed Disk Adaptor
5	_____	_____	_____	6 Diskette Adaptor
6	_____	_____	_____	7
7	_____	_____	_____	8 Combination Adaptor

Cluster Adapter Number _____

Station Address _____

Remote IPL (Is/Is not) Selected _____

Installation Requirements

If your system has not been set up, refer to the *IBM Industrial Computer Operator's Guide* for instructions to install and set up the system. After the system is set up, install the Combination Adapter cable using the instructions that follow.

After you install the cable, file these instructions in the *Operator's Guide*.

Note: The Combination Adapter card should be installed in your system before you begin installing this cable. If the adapter is not installed, refer to "Installing an Adapter Card" in the *Operator's Guide* for installation procedures.

Tools Required

A small flat-blade screwdriver is required to install this cable.

Note: The non-IBM devices shown on the following pages are for illustration only, and their use here does not constitute a recommendation or an endorsement by IBM. The selection, interconnection, and use of another manufacturer's device are the responsibility of the customer.

Installation instructions

1. Set all power switches to Off.
2. Unplug the system unit's power cord from the wall outlet.
3. Position the unit to allow access to the rear.
4. Connect the cable (9-pin connector end) to the Combination Adapter connector at the rear of the unit, as shown below. Tighten the screws by turning them clockwise.

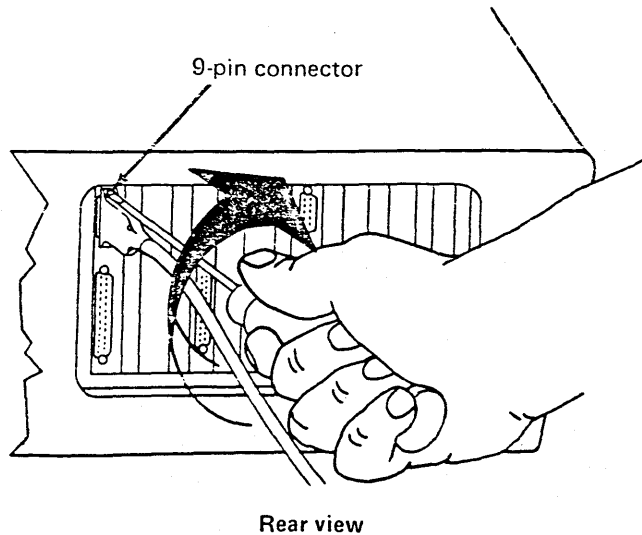

Installation Instructions (*continued*)

5. Connect the other end of the cable as shown below. Tighten the screws by turning them clockwise.

Modem or other
RS-232-C data
communications equipment
(user-supplied)

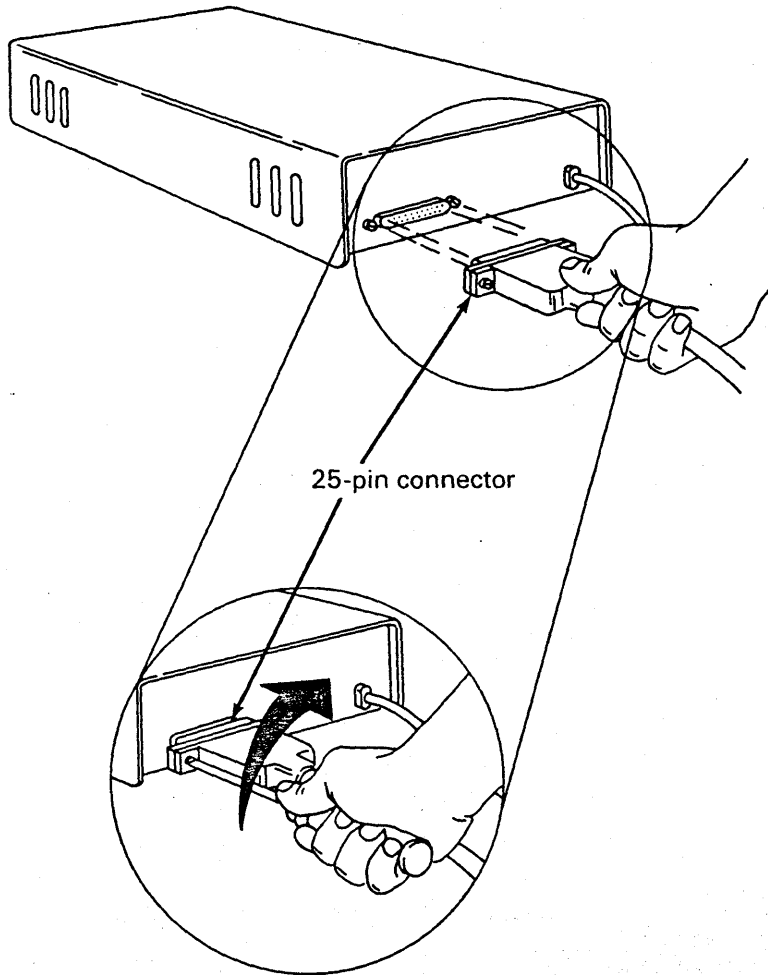

Your IBM Combination Adapter cable is now installed and ready for use. File these instructions in the *Operator's Guide*

Limited Warranty

The International Business Machines Corporation warrants this IBM Industrial Computer Product to be in good working order for a period of 90 days from the date of purchase from IBM or an authorized IBM Industrial Computer Dealer. Should this Product fail to be in good working order at any time during this 90 day warranty period, IBM will, at its option, repair or replace this Product at no additional charge except as set forth below. Repair parts and replacement Products will be furnished on an exchange basis and will be either reconditioned or new. All replaced parts and Products become the property of IBM. This limited warranty does not include service to repair damage to the Product resulting from accident, disaster, misuse, abuse, or non-IBM modification of the Product.

Limited Warranty service may be obtained by delivering the Product during the 90 day warranty period to an authorized Industrial Computer Dealer and providing proof of purchase date. If this Product is delivered by mail, you agree to insure the Product or assume the risk of loss or damage in transit, to prepay shipping charges to the warranty service location and to use the original shipping container or equivalent. Contact an authorized IBM Industrial Computer Dealer or write to IBM Industrial Computer Products, Marketing, P.O. Box 1328, Boca Raton, Florida 33432, for further information.

ALL EXPRESS AND IMPLIED WARRANTIES FOR THIS PRODUCT INCLUDING THE WARRANTIES OF MERCHANTABILITY AND FITNESS FOR A PARTICULAR PURPOSE, ARE LIMITED IN DURATION TO A PERIOD OF 90 DAYS FROM THE DATE OF PURCHASE, AND NO WARRANTIES, WHETHER EXPRESS OR IMPLIED, WILL APPLY AFTER THIS PERIOD. SOME STATES DO NOT ALLOW LIMITATIONS ON HOW LONG AN IMPLIED WARRANTY LASTS, SO THE ABOVE LIMITATIONS MAY NOT APPLY TO YOU.

IF THIS PRODUCT IS NOT IN GOOD WORKING ORDER AS WARRANTED ABOVE, YOUR SOLE REMEDY SHALL BE REPAIR OR REPLACEMENT AS PROVIDED ABOVE. IN NO EVENT WILL IBM BE LIABLE TO YOU FOR ANY DAMAGES, INCLUDING ANY LOST PROFITS, LOST SAVINGS OR OTHER INCIDENTAL OR CONSEQUENTIAL DAMAGES ARISING OUT OF THE USE OR OF INABILITY TO USE SUCH PRODUCT, EVEN IF IBM OR AN AUTHORIZED IBM INDUSTRIAL COMPUTER DEALER HAS BEEN ADVISED OF THE POSSIBILITY OF SUCH DAMAGES, OR FOR ANY CLAIM BY ANY OTHER PARTY.

SOME STATES DO NOT ALLOW EXCLUSION OR LIMITATION OF INCIDENTAL OR CONSEQUENTIAL DAMAGES FOR CONSUMER PRODUCTS, SO THE ABOVE LIMITATIONS OR EXCLUSIONS MAY NOT APPLY TO YOU.

THIS WARRANTY GIVES YOU SPECIFIC LEGAL RIGHTS, AND YOU MAY ALSO HAVE OTHER RIGHTS WHICH MAY VARY FROM STATE TO STATE.

IBM Combination Adapter Cable for Industrial Computer

Inventory Checklist

This carton contains:

- IBM Combination Adapter cable
- Wrap plug.

If any items are missing or damaged, notify your place of purchase.

Refer to the Limited Warranty statement on the back of this sheet.

Terms and Abbreviations

adapter. An auxiliary device or unit used to extend the operation of another system.

ASCII. American Standard Code for Information Interchange. The standard code, using a coded character set consisting of 7-bit coded characters (8 bits including parity check), used for information exchange between data-processing systems, data communication systems, and associated equipment. The ASCII set consists of control characters and graphic characters.

backup. Duplicating data from a fixed disk drive or diskette to a diskette which ensures availability of data in the event of loss or damage to the original.

BASIC. Beginner's all-purpose symbolic instruction code. A programming language that uses common English words.

basic input/output system (BIOS). The feature of the IBM Personal Computer that provides the level control of the major I/O devices, and relieves the programmer from concern about hardware device characteristics.

binary synchronous communications (BSC). A uniform procedure, using a standardized set of control characters and control character sequences for synchronous transmission of binary-coded data between stations.

BIOS. Basic input/output system.

BSC. Binary synchronous communications.

byte. A sequence of eight adjacent binary digits that are operated upon as a unit. A binary character operated upon as a unit. The representation of a character.

characters per second (cps). A standard unit of measurement for the speed at which a printer prints.

computer. A functional unit that can perform substantial computation, including numerous arithmetic operations or logic operations, without intervention by a human operator during a run.

cps. Characters per second.

CPU. Central processing unit.

cursor. In computer graphics, a movable marker that is used to indicate a position on a display. A displayed symbol that acts as a marker to help the user locate a point in text, in a system command, or in storage. A movable spot of light on the screen of a display device, usually indicating where the next character is to be entered, replaced, or deleted.

data. A representation of facts, concepts, or instructions in a formalized manner suitable for communication, interpretation, or processing by human or automatic means. Any representations, such as characters or analog quantities, to which meaning is, or might be assigned.

DIP. Dual in-line package.

DIP switch. One of a set of small switches mounted in a dual in-line package.

disk. Generally, a magnetic disk.

diskette. A thin, flexible magnetic disk and a semirigid protective jacket, in which the disk is permanently enclosed. Synonymous with flexible disk.

Terms and Abbreviations

diskette drive. A device for storing data on and retrieving data from a diskette.

display. A visual presentation of data. A device for visual presentation of information on any temporary character imaging device. To present data visually.

FCC. Federal Communications Commission.

fixed disk drive. In the IBM Personal Computer, a unit consisting of nonremovable magnetic disks, and a device for storing data on and retrieving data from the disks.

flexible disk. Synonym for diskette.

format. The arrangement or layout of data on a data medium.

hardware. Physical equipment used in data processing, as opposed to programs, procedures, rules, and associated documentation. Contrast with software.

head. A device that reads, writes, or erases data on a storage medium; for example, a small electromagnet used to read, write, or erase data on a magnetic disk.

interface. A device that alters or converts actual electrical signals between distinct devices, programs, or systems.

joystick. In computer graphics, a lever that can pivot in all directions and that is used as a locator device.

Kb. 1024 bytes.

load. In programming, to enter data into storage or working registers.

magnetic disk. A flat circular plate with a magnetizable surface layer on which data can be stored by magnetic recording. See also diskette.

Mb. 1 048 576 bytes.

microprocessor. An integrated circuit that accepts coded instructions for execution; the instructions may be entered, integrated, or stored internally.

modem (modulator-demodulator). A device that converts serial (bit-by-bit) digital signals from a business machine (or data communication equipment) to analog signals that are suitable for transmission in a telephone network. The inverse function is also performed by the modem on reception of analog signals.

module. A program unit that is discrete and identifiable with respect to compiling, combining with other units, and loading. A packaged functional hardware unit designed for use with other components.

monitor. Synonym for cathode ray tube display (CRT display).

most-significant digit. The leftmost (non-zero) digit. See also high-order position.

operating system. Software that controls the execution of programs; an operating system may provide services such as resource allocation, scheduling, input/output control, and data management.

output. Pertaining to a device, process, or channel involved in an output process, or to the data or states involved in an output process.

output process. The process that consists of the delivery of data from a data-processing system, or from any part of it. The return of information from a data processing system to an end user, including the translation of data from a machine language to a language that the end user can understand.

personal computer. A small home or business computer that has a processor and keyboard and that can be connected to a television or some other monitor. An optional printer is usually available.

power supply. A device that produces the power needed to operate electronic equipment.

processor. In a computer, a functional unit that interprets and executes instructions. A functional unit, part of another unit such as a terminal or a processing unit, that interprets and executes instructions. Deprecated term for processing program. See microprocessor.

program. A series of actions designed to achieve a certain result. A series of instructions telling the computer how to handle a problem or task. To design, write, and test computer programs.

programming language. An artificial language established for expressing computer programs. A set of characters and rules, with meanings assigned prior to their use, for writing computer programs.

programming system. One or more programming languages and the necessary software for using these languages with particular automatic data-processing equipment.

prototype card. A blank circuit card which can be used to create custom adapters.

RAM. Random access memory. Read/write memory.

random access memory (RAM). Read/write memory.

read-only memory (ROM). A storage device whose contents cannot be modified. The memory is retained when power is removed.

read/write memory. A storage device whose contents can be modified. Also called RAM.

reverse video. A form of highlighting a character, field, or cursor by reversing the color of the character, field, or cursor with its background; for example, changing a red character on a black background to a black character on a red background.

RF. Radio frequency.

RF modulator. The device used to convert the composite video signal to the antenna level-input of a home TV.

ROM. Read-only memory.

ROM/BIOS. The ROM resident basic input/output system, which provides the level control of the major I/O devices in the computer system.

run. A single continuous performance of a computer program or routine.

schematic. The representation, usually in a drawing or diagram form, of a logical or physical structure.

SDLC. Synchronous Data Link Control.

sector. That part of a track or band on a magnetic drum, a magnetic disk, or a disk pack that can be accessed by the magnetic heads in the course of a predetermined rotational displacement of the particular device.

setup. In a computer that consists of an assembly of individual computing units, the arrangement of interconnections between the units, and the adjustments needed for the computer to operate. The preparation of a computing system to perform a job or job step. Setup is usually performed by an operator and often involves performing routine functions, such as mounting tape reels. The preparation of the system for normal operation.

signal. A variation of a physical quantity, used to convey data.

software. Computer programs, procedures, and rules concerned with the operation of a data-processing system. Contrast with hardware.

storage. A storage device. A device, or part of a device, that can retain data. The retention of data in a storage device. The placement of data into a storage device.

Synchronous Data Link Control (SDLC). A protocol for management of data transfer over a data link.

synchronous transmission. Data transmission in which the time of occurrence of each signal representing a bit is related to a fixed time frame. Data transmission in which the sending and receiving devices are operating continuously at substantially the same frequency and are maintained, by means of correction, in a desired phase relationship.

syntax. The relationship among characters or groups of characters, independent of their meanings or the manner of their interpretation and use. The structure of expressions in a language. The rules governing the structure of a language. The relationships among symbols.

text. In ASCII and data communication, a sequence of characters treated as an entity if preceded and terminated by one start-of-text and one end-of-text transmission control character, respectively.

track. The path or one of the set of paths, parallel to the reference edge on a data medium, associated with a single reading or writing component as the data medium moves past the component. The portion of a moving data medium such as a drum, or disk, that is accessible to a given reading head position.

translate. To transform data from one language to another.

transmission. The sending of data from one place for reception elsewhere. In ASCII and data communication, a series of characters including headings and text. The dispatching of a signal, message, or other form of intelligence by wire, radio, telephone, or other means. One or more blocks or messages. For BSC and start-stop devices, a transmission is terminated by an EOT character. Synonymous with data transmission.

typematic. Keyboard buttons that will repeat when held depressed.

video. Computer data or graphics displayed on a cathode ray tube, monitor, or display.

word. A character string or a bit string considered as an entity. See computer word.

write. To make a permanent or transient recording of data in a storage device or on a data medium.

Index

A

adapters

- Cluster Adapter 5-3
- Combination Adapter 1-3
- Diskette Drive Adapter 1-3

adapters, options 1-14

adjustments

- keyboard tilt position 1-11
- vertical hold 1-13
- vertical size 1-13

Alt key 1-7

B

Backspace key 1-7

brightness control 1-12

C

cable

- combination adapter 1-4

cable retaining brackets, installing the 2-5

Caps Lock key 1-6

Cluster Adapter, checking the 5-3

Combination Adapter 1-3

- primary communications operation 1-3
- RS-232C communications 1-3

Combination Adapter cable 1-4

connecting cables, steps for 2-2

contrast control 1-12

controls

- brightness 1-12
- contrast 1-12
- power 1-12
- power-on indicator 1-12
- vertical hold 1-13
- vertical size 1-13

Ctrl key 1-7

Cursor Down key 1-9

Cursor Left key 1-9

Cursor Right key 1-9

Cursor Up key 1-9

D

Del key 1-9

diagnostics

- errors 5-13
- loading 5-16
- testing 5-1
- tests 5-16

diskette

- formatting 5-8
- handling 3-2
- inserting in a diskette drive 3-4
- removing from a diskette drive 3-5

Diskette Drive Adapter 1-3

Index

display
 front view 1-12
 rear view 1-13

E

electrical connections, checking 5-1
End key 1-9
Enter key 1-6
errors
 diagnostic testing 5-13
 POST 5-6
Esc key 1-7

F

filters
 IBM Industrial Color Display 4-4
 system unit 4-2
formatting a diskette 5-8
function keys 1-10

G

graphics printer diagnostic test 5-1400-1

H

handling diskettes 3-2
Home key 1-9

I

IBM industrial display 1-12
in-use light (for diskette drive) 3-5
Ins key 1-9

K

keyboard
 function keys 1-10
 numeric keypad 1-8
 typewriter keys 1-6
keyboard tilt position, adjusting the 1-11

keys
 Alt (Alternate) 1-7
 Backspace 1-7
 Caps Lock 1-6
 Ctrl (Control) 1-7
 Cursor Down 1-9
 Cursor Left 1-9
 Cursor Right 1-9
 Cursor Up 1-9
 Del (Delete) 1-9
 End 1-9
 Enter 1-6
 Esc (Escape) 1-7
 Home 1-9
 Ins (Insert) 1-9
 Minus 1-9
 Num Lock 1-9
 PgDn (Page Down) 1-9
 PgUp (Page Up) 1-9
 Plus 1-9
 PrtSc (Print Screen) 1-6
 Scroll Lock 1-9
 Shift 1-7
 Space bar 1-7
 Tab 1-7

L

loading diagnostics 5-16
location of
 adapters 1-4
 filter 1-4
 keyboard cable connector 1-4
 Power switch 1-4
 power-cord connector 1-4
 system unit 1-4

M

Minus key 1-9

N

Num Lock key 1-9
numeric keypad 1-8

O

options
 adapters 1-14

cable 1-14
keylock 1-14
screen cover (clear) 1-14

P

PgDn key-19
PgUp key 1-9
Plus key 1-9
POST 2-8, 5-4
POST errors 5-6
power control (on the display) 1-12
power-on indicator (on the display) 1-12
power-on self-test (POST), running the 2-8, 5-4
PrtSc (Print Screen) 1-6

S

Scroll Lock key 1-9
Shift key 1-7
Space Bar 1-7

system unit
front view 1-4
rear view 1-4

T

Tab key 1-7
thermal warning 3-6
typewriter keys 1-6
typical IBM Industrial Computer 1-2

V

vertical hold control 1-13
vertical size control 1-13

W

write-protecting a diskette 3-3

IBM 5531 Industrial Computer
Operator's Guide
Part Number 6219645

READER'S
COMMENT
FORM

This manual is part of a library that serves as a reference source for systems analysts, programmers, and operators of IBM systems. You may use this form to communicate your comments about this publication, its organization, or subject matter, with the understanding that IBM may use or distribute whatever information you supply in any way it believes appropriate without incurring any obligation to you. Your comments will be sent to the author's department for whatever review and action, if any, are deemed appropriate.

Note: *Copies of IBM publications are not stocked at the location to which this form is addressed. Please direct any requests for copies of publications, or for assistance in using your IBM system, to your IBM representative or to the IBM branch office serving your locality.*

Note: Staples can cause problems with automated mail sorting equipment.
Please use pressure sensitive or other gummed tape to seal this form.

Thank you for your cooperation. No postage stamp necessary if mailed in the U.S.A. (Elsewhere, an IBM office or representative will be happy to forward your comments or you may mail directly to the address in the Edition Notice on the back of the title page.)

Cut or Fold Along Line

Reader's Comment Form

Fold and tape

Please Do Not Staple

Fold and tape



NO POSTAGE
NECESSARY
IF MAILED
IN THE
UNITED STATES

BUSINESS REPLY MAIL
FIRST CLASS PERMIT NO. 40 ARMONK, N.Y.



POSTAGE WILL BE PAID BY ADDRESSEE:

International Business Machines Corporation
Industrial Information Products, Department 27X
P.O. Box 1328-4327
Boca Raton, Florida 33432

Fold and tape

Please Do Not Staple

Fold and tape



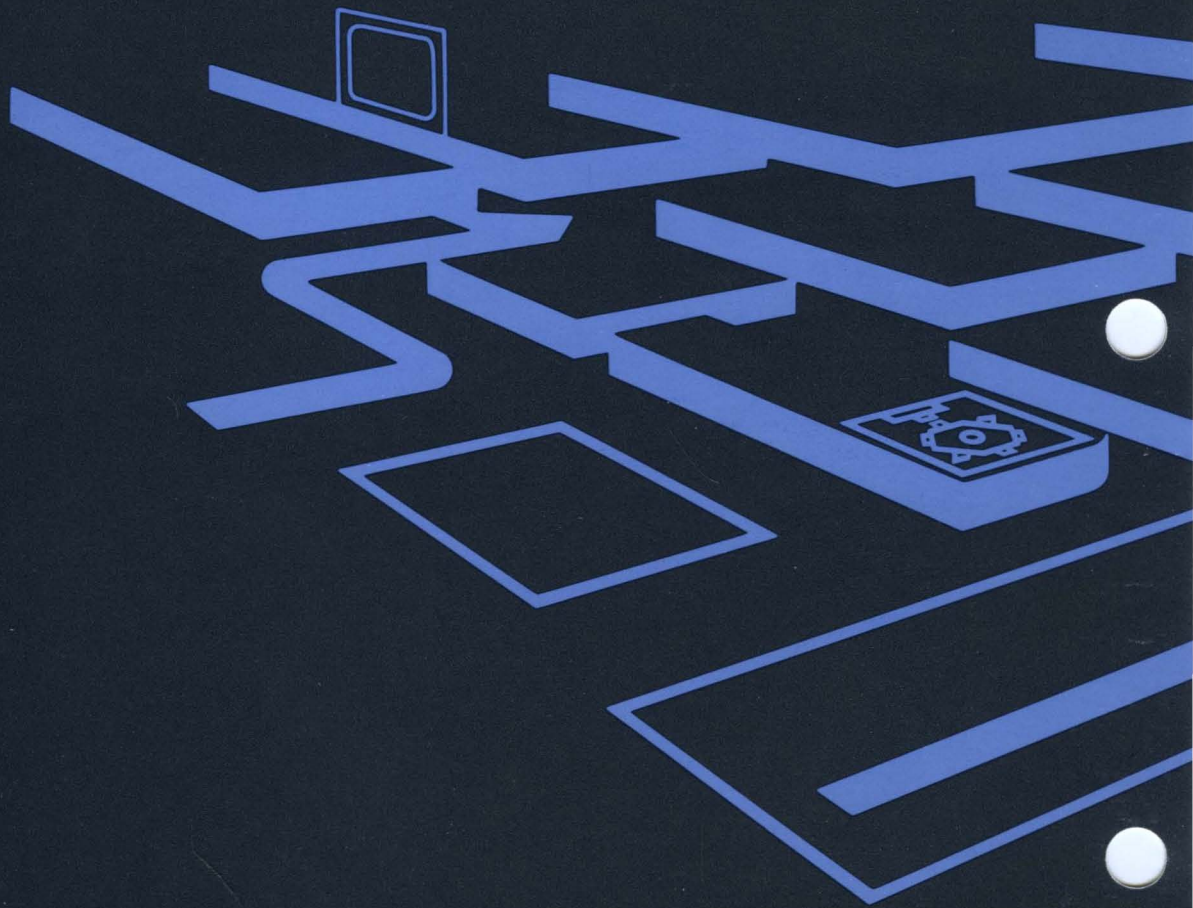

6219645