

Omninet Disk System Installation Guide

Apple II

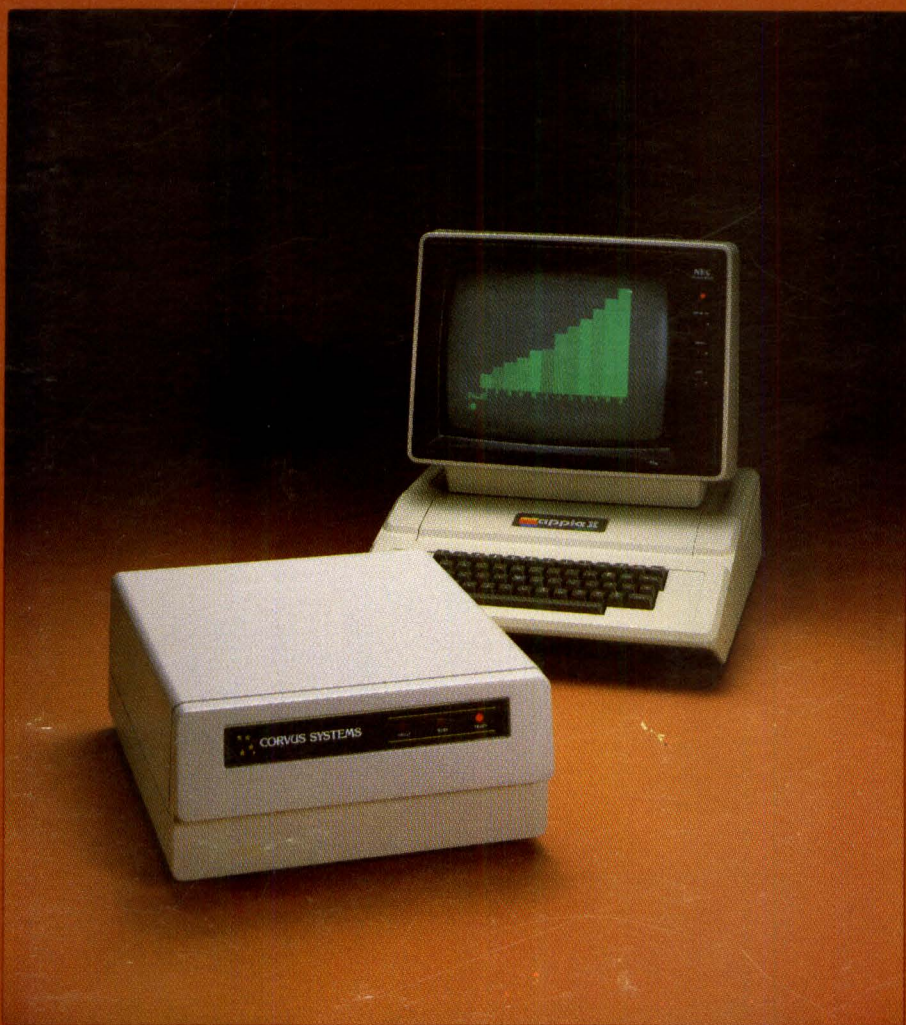

DISCLAIMER OF ALL WARRANTIES & LIABILITIES

Corvus Systems, Inc. makes no warranties, either expressed or implied, with respect to this manual or with respect to the software described in this manual, its quality, performance, merchantability, or fitness for any particular purpose. Corvus Systems, Inc. software is sold or licensed "as is." The entire risk as to its quality or performance is with the buyer and not Corvus Systems, Inc., its distributor, or its retailer. The buyer assumes the entire cost of all necessary servicing, repair, or correction and any incidental or consequential damages. In no event will Corvus Systems, Inc. be liable for direct, indirect, incidental or consequential damages, even if Corvus Systems, Inc. has been advised of the possibility of such damages. Some states do not allow the exclusion or limitation of implied warranties or liabilities for incidental or consequential damages, so the above limitation may not apply to you.

Every effort has been made to insure that this manual accurately documents the operation and servicing of Corvus products. However, due to the ongoing modification and update of the software along with future products, Corvus Systems, Inc. cannot guarantee the accuracy of printed material after the date of publication, nor can Corvus Systems, Inc. accept responsibility for errors or omissions.

NOTICE

Corvus Systems, Inc. reserves the right to make changes in the product described in this manual at any time without notice. Revised manuals and update sheets will be published as needed and may be purchased by writing to:

Corvus Systems, Inc.
2029 O'Toole Avenue
San Jose, CA 95131
Telephone: (408) 946-7700
TWX 910-338-0226

This manual is copywrited and contains proprietary information. All rights reserved. This document may not, in whole or in part be copied, photocopied, reproduced, translated or reduced to any electronic medium or machine readable form without prior consent, in writing, from Corvus Systems, Inc.

Copyright© 1982 by Corvus Systems, Inc. All rights reserved.

Mirror® patent pending, The Corvus Concept™, Transporter™, Corvus OMNINET™, Corvus Logical™, Time Travel Editing™, EdWord™, Constellation™, Corvus™, Corvus Systems™, Personal Workstation™, Tap Box™, Passive Tap Box™, Active Junction Box™, Omninet Unit™ are trademarks of Corvus Systems, Inc.

FCC WARNING

This equipment generates, uses, and can radiate radio frequency energy and if not installed and used in accordance with the instruction manual, may cause interference to radio communications. As temporarily permitted by regulation it has not been tested for compliance with the limits for Class A computing devices pursuant to Subpart J of Part 15 of FCC Rules, which are designed to provide reasonable protection against such interference. Operation of this equipment in a residential area is likely to cause interference in which case the user at his own expense will be required to take whatever measures may be required to correct the interference.

OMNINET DISK SYSTEM INSTALLATION GUIDE

PART NO.: 7100-03105

DOCUMENT NO.: AP2/21-11/1.3

RELEASE DATE: November, 1982

Apple II®

Apple II is a registered trademark of
Apple Computers Inc.

TABLE OF CONTENTS

Scope.....	1
Conventions.....	3
Chapter One: Introduction to Omninet.....	5
Hardware and software.....	6
Chapter Two: Hardware setup.....	7
Setting up the network trunk cable.....	7
Terminating the network trunk cable.....	8
Installing the network device tap boxes.....	10
Installing the Omninet disk server.....	11
Installing the Corvus hard disk.....	14
Checking the voltage settings.....	15
Connecting the Apple II to the network.....	17
Powering on the disk server and disk drive.....	19
Chapter Three: Initializing for Apple BASICS (DOS 3.3).....	21
Booting from diskette.....	21
Initializing for BASICS.....	23
Initializing the 2nd half of a Model 20 drive.....	25
Installing the operating system patch.....	26
Copying BASICS files to the hard disk.....	28
Initializing Volume Directories.....	30
Upgrading BASICS with Constellation software.....	33
Copying Constellation files to the hard disk.....	34
Initializing with CONSTCREATE.....	36
Initializing for a Model 20 Drive.....	37
Setting Boot to Constellation.....	39
Initialize User Table.....	39
Reboot.....	42
Chapter Four: Initializing for Pascal.....	43
Booting from diskette.....	43
Creating the SYS: diskette.....	44
Initializing for Pascal.....	49
Copying Pascal files to the hard disk.....	50
Initializing the 2nd half of a Model 20 drive.....	56
Upgrading Pascal with Constellation software.....	57
Create Volume—Private.....	57
File Transfer.....	59
Volume Initialization.....	62
Volume Initialization for a Model 20 Drive.....	63
Setting Boot to Constellation.....	67

Chapter Five: Adding BASICS to Pascal	69
Creating BASICS volumes	69
Installing the operating system patch	72
Initializing Volume Directories	73
Copying BASICS files to the hard disk	76
Upgrading BASICS/Pascal with Constellation	78
Upgrading the BASICS area	78
Adding BASICS to a Model 20 Drive	82
Setting Boot to Constellation	83
Reboot	84

SCOPE

This guide takes you through the procedure to install the basic configuration for an Omninet Disk System Network™ for the Apple II™ computer. Only the hardware installation and software initialization of the system is described.

Details on network (Constellation) software are contained in the System Manager's Guide for Apple II Computers. Information on other utilities (e.g., the use of the Mirror) is contained in the Disk System User Guide for Apple II Computers.

CONVENTIONS

The word **“Type”** is used throughout this guide to mean that two or more letters, numbers, or symbols are to be entered at the computer keyboard. The form of a **“Type”** statement is as follows:

Type RUN BSYSGEN [RETURN]

Keypop symbols within or at the end of a statement to be typed represent a single typewriter key to be pressed.

Examples of these keytop symbols include [RETURN] and [SPACE]. When a keytop symbol is used, press the key to which it refers; do not type out the word shown within the keytop symbol. For example, **“Press [SPACE]”** does not mean that you should type out the letters S-P-A-C-E.

The word **“Press”** is used throughout this guide to mean that a single letter, number, or symbol is to be entered at the computer keyboard. Examples:

Press Y

Press 3

Press [RETURN]

INTRODUCTION TO OMNINET

The Corvus Omninet is a local area network of common bus topology. In a common bus type network, the transmission line is shared, as on a telephone party line. The Omninet common bus is a cable composed of a pair of 20-gauge insulated wires twisted together inside a common insulated cover. This cable is called the network trunk.

The Corvus Omninet allows up to 64 devices to be interconnected on the network trunk. The two types of devices which are discussed in this guide are disk servers and transporter interface cards. A disk server permits a Corvus hard disk to communicate over the Omninet network trunk. A transporter allows a microcomputer to do the same.

Network devices, such as disk servers and transporters, are connected to the Omninet trunk at network taps. A network tap consists of a tap box on the network trunk, and a tap cable which connects the network device to the Omninet trunk line.

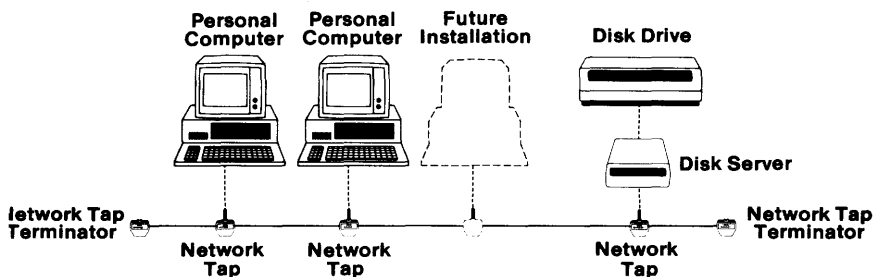

Diagram of the Omninet Network System

Hardware and Software

You will need the following minimum hardware:

- Corvus Hard Disk System
- Omninet Disk Server Unit
- Trunk Cable (20-gauge twisted pair wire: Belden™* type 8205 VW-1 or equivalent)
- 3 tap boxes
- Wire strippers
- Small common screwdriver
- Apple II transporter
- Apple II computer with monitor and diskette drive
- Apple language card if system will be Pascal
- 2 100 ohm resistors

You will need the following software:

BASICS

- Corvus AP Utilities for BASICS—DOS 3.3
- Corvus Constellation AP utilities for BASICS—DOS 3.3

Pascal

- Corvus AP Utilities for Pascal (Volume 1 and 2)
- Corvus Constellation AP Utilities for Pascal
- Apple Pascal Language System (APPLE1, 2, and 3)
- Formatted blank diskette

*57604
1-312-250-0900*

*Belden is a trademark of the Belden Corporation

HARDWARE SETUP

Setting up the Network Trunk Cable

Step 1: Planning Your Omninet Network

The first step in constructing an Omninet disk system network is planning its layout. Carefully design your network before starting hardware installation—lay it out on paper if necessary. Remember a few basic requirements:

Maximum length of network trunk:
1000 feet (approximately 300 meters)

Maximum distance from trunk cable to network device:
15 feet (approximately 5 meters)

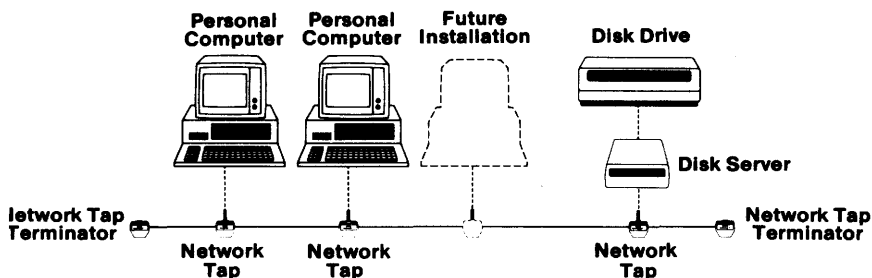

The Basic Network

Step 2: Installing the Network Trunk Cable

Once the network has been designed, install the network trunk. Use unshielded, 20-gauge twisted pair wire (Belden type 8205 VW-1 or equivalent). The trunk should be one continuous run—network taps will be cut into the trunk after it is installed.

Avoid placing the network trunk cable in locations where it may get pulled, stepped on, or will obstruct passageways.

Terminating the Network Trunk Cable

In order for the Omnet network to function correctly, the trunk cable must be terminated at both ends with a resistor. This prevents interference from signal echo.

Step 1: Preparing the Trunk Cable

First, strip the twisted wire pair at end of the trunk cable. Use the wire strippers supplied by Corvus to cut off approximately one inch of the outer covering (2.5 centimeters). Be careful not to cut the insulation on the red or black wire.

Use the wire stripper hole marked "20" (for 20-gauge wire) to strip both the red and the black wires about $\frac{3}{8}$ of an inch (one cm). Be careful not to nick the wire when stripping it.

Step 2: Connecting the End Tap Box to the Trunk Cable

Open the tap box. Inside are six grommets and four screws. Slide a rubber grommet over the trunk cable end.

Inside the tap box is a terminal strip. The A and B pairs are electrically connected (see diagram below).

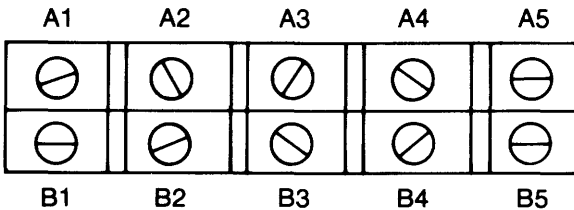

Terminal Strip

Insert the black stripped wire into B1 and tighten down the screw. Insert the red stripped wire into B2 and tighten down the screw.

Step 3: Installing the Terminating Resistor

Install a 100 ohm, ¼ watt, $\pm 5\%$ resistor (supplied by Corvus) between A1 and A2 on the terminal strip. Insert one end of the resistor into A1 and tighten down the screw. Insert the other end into A2 and tighten down the screw.

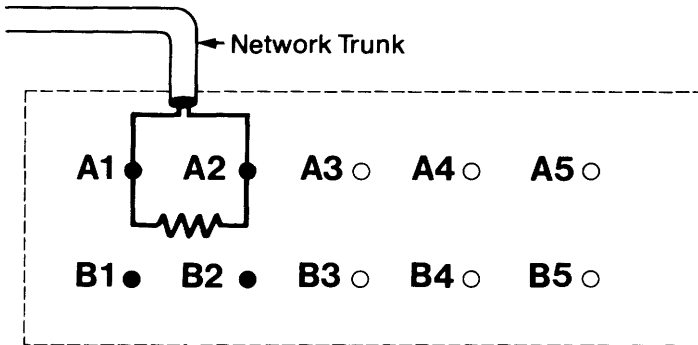

Inside of Tap Box Showing Cable and Resistor

Step 4: Closing the Tap Box

The tap box should be closed tightly. Place a rubber grommet on each tap box cutout. Once the rubber grommets have been placed into the cutout holes, the lid of the tap box can be secured with four screws, one in each corner of the box.

Step 5: Repeat

After one end of the trunk cable is terminated, terminate the other end by repeating the procedure just performed.

Installing Network Device Tap Boxes

Each network device (computer or Omnet Disk Server) requires a network device tap. A network device tap consists of a tap box installed on the trunk cable, and a 15 foot (or less) cable which connects the device to the tap box.

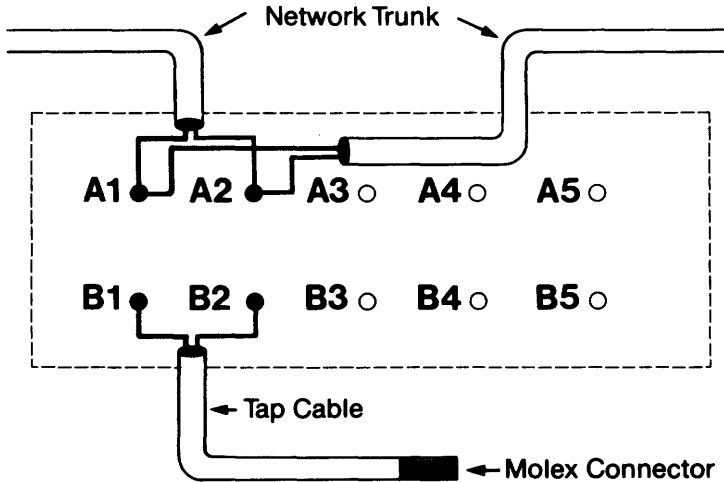

A Simple Network Tap

Step 1: Installing the Tap Box

Cut the network trunk cable where the tap box will be located.

Remove approximately 1 inch (2.5 cm) of the outer insulation (being careful not to cut the insulation on the two wires). Strip off about $\frac{3}{8}$ " insulation from the red wire and the black wire, being careful to avoid cutting the wire itself. Repeat for the other cable end.

Slide a rubber grommet over each end of the cut trunk cable wire.

Insert the two black stripped wires into A1 on the terminal strip, and tighten down the screw.

Insert the two red stripped wires into A2 on the terminal strip, and tighten down the screw.

*Molex is a trademark of the Molex Corporation

Step 2: Attaching the Tap Cable

Slide a rubber grommet over the stripped wire end of the tap cable approximately 4 inches.

Insert the black stripped wire into B1 on the terminal strip in the tap box, and tighten down the screw.

Insert the red stripped wire into B2 on the terminal strip in the tap box, and tighten down the screw.

Insert rubber grommets into notches in the tap box, and close lid securely.

Step 3: Repeat

Repeat the above procedure to install another tap onto the network trunk. One tap will be used by the disk server, the other by a transporter.

Installing the Omninet Disk Server

The disk server is attached to the network trunk cable by means of a tap box and tap cable, like the other network devices.

Step 1: Installing a Network Tap

First, install a network tap box and tap cable according to the directions in the previous step, for the Omninet disk server.

Step 2: Connecting the Tap Cable to the Disk Server

Open the disk server unit by loosening the two screws located on the back panel that secure the top of the unit, then lift and slide the top cover off the base.

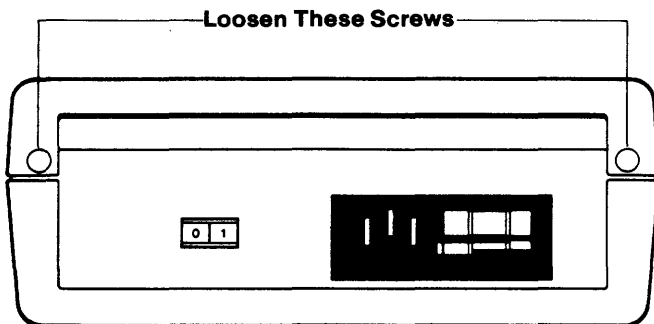

The Disk Server Showing Screws

Connect the small, plastic, three pronged female connector on the end of the tap cable to the three pronged connector on the printed circuit board inside the disk server. The male connector is located near the rear of the unit. The two little tabs on the female connector slide over the single back tab on the connection, and gently lock the tap cable in place.

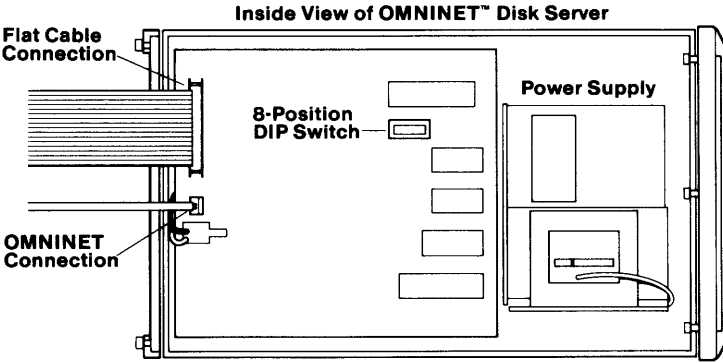

Inside View of the Omninet Disk Server Unit

Step 3: Connecting the Flat Cable to the Disk Server

Take one end of the flat cable, and connect it to the flat cable connection on the disk server printed circuit board. The colored stripe on the flat cable should be closest to the three pronged connector. The flat cable should be installed so that it exits toward the rear of the disk server unit.

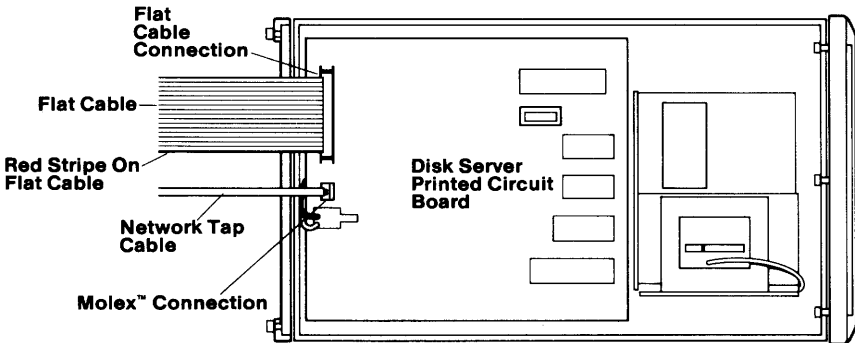

Flat Cable and Network Tap Connection

Step 4: Setting the Device Address on the Disk Server

The device address for the disk server is set with an 8-position DIP switch located near the top part of the disk server printed circuit board. The DIP switch positions are labeled 1 through 8. Set the DIP switches as follows:

SWITCH	SETTING	MEANING
1	ON	▶
2	ON	▶
3	ON	▶ This sets the device address to zero
4	ON	▶
5	ON	▶
6	ON	▶
7	ON	This sets the network bias.
8	OFF	This switch is not used.

By turning switches 1-6 ON, the disk server's device address is set to zero. By turning switch 7 ON, the network bias (or base signal), is set. Only one network device is used to set network bias.

Switch 8 is not used at the present time, and should be in the OFF position.

Step 5: Replacing the Disk Server Cover

Slide the cover back in place. Tighten the two screws on the back of the disk server unit that hold the cover in place.

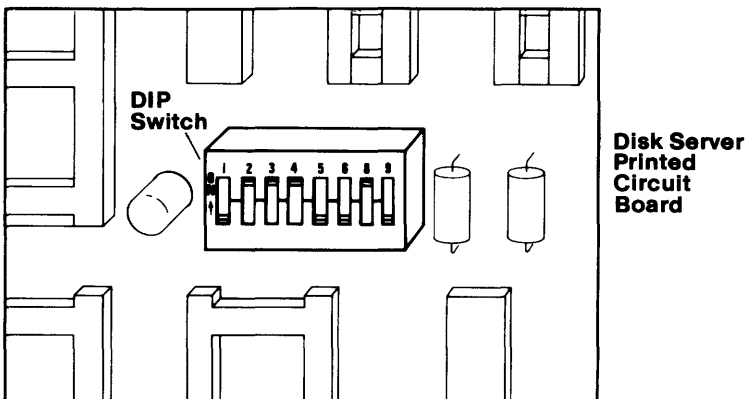

DIP Switch for Setting the Device Address

Installing the Corvus Hard Disk

Step 1: Setting up the Hard Disk

Place the Corvus hard disk on a flat level surface, either on its side or on its base. Since the Corvus disk is a precision instrument, it should be handled carefully. The disk drive must not be operated when the unit is upside down or tilted.

NOTE—WARNING

Be sure the disk drive has adequate ventilation. To ensure cool running equipment, the air slots on the drive should not be blocked or covered. Avoid putting the drive unit in a closed area, such as a box or drawer.

Do not place electromagnetic field generating equipment (such as a video cassette recorder, display monitor, or television) on top of the drive unit.

Step 2: Checking the Drive Controller Switches

Approximately two inches below the indicator lights on the front of the drive unit, the front panel protrudes slightly. Directly beneath the lights, and up under the lip of this protrusion, are the four drive controller switches.

Flip all four drive controller switches to the left.

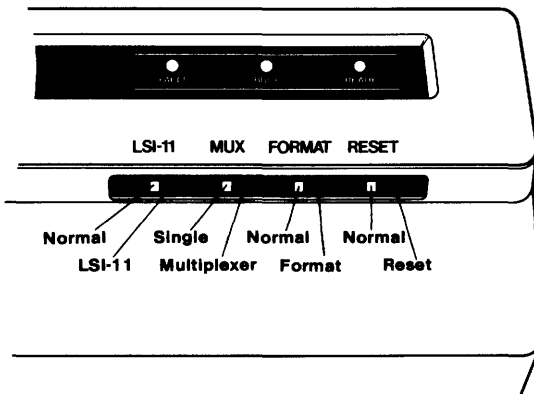

Front Panel Switches

Step 3: Attaching the Flat Cable to the Drive

On the rear of the Corvus drive there are two flat cable connections, one labeled PROCESSOR and the other labeled DRIVE.

Plug the other end of the flat cable coming from the disk server unit into the connection labeled PROCESSOR. The cable should lead down and away from the drive. The colored stripe on the cable edge should be on the right side, closest to the fuse holder.

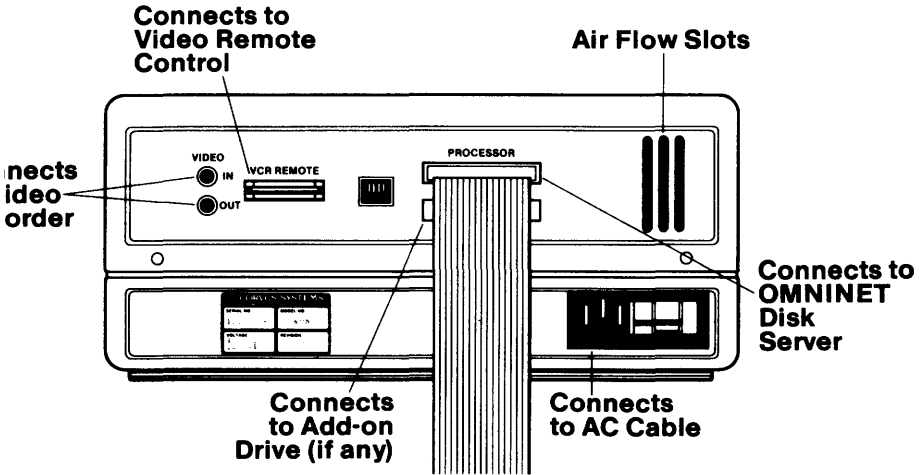

Back Panel of the Corvus Drive

Checking Voltage Settings

Step 1: Checking the Voltage Settings on Corvus Equipment

Make sure the voltage setting for the disk server unit and the hard disk match the local voltage supply: either 100, 120, 220 or 240 volts. The equipment can use either 50 or 60 Hz power in any of the voltage settings. The voltage setting, fuse, and local voltage supply must match. Any type of mismatch here can cause damage to the equipment. To verify the voltage setting, look at the bottom right corner on the back of the equipment. There you will find the AC power cord connector and fuse receptacle. Directly underneath the fuse holder, the voltage setting is displayed.

Step 2: Changing the Voltage Setting

If the voltage setting displayed matches the voltage supply in your region, continue to the next step. If you must change the voltage setting, proceed as follows:

Slide open the clear plastic cover door, pull the fuse-pull lever to the left, and remove the fuse.

Use longnose pliers to carefully pull the voltage circuit board out of the fuse housing. To select the proper operating voltage, position the circuit board so that the desired voltage is displayed on the top left side of the board. Push the board firmly back into the module slot.

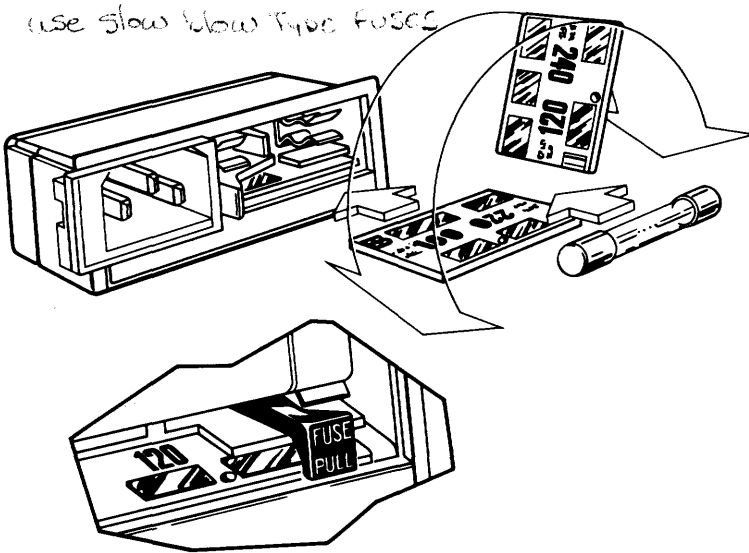

Voltage Setting and Fuses

Do not reinsert the fuse you have removed if you have chosen a different voltage setting than the one originally set on the equipment. Select the correct fast blow fuse using the following table:

DEVICE	100/200 VOLTAGE	200/240 VOLTAGE
Disk Server	1/2 amp	1/4 amp
Disk System	2 amp	1 amp

To return the fuse to its holder, push the fuse-pull lever to the right, and insert the fuse into the holder. Slide the clear

plastic cover over the fuse holder, so the AC power cord connection is unobstructed.

Connecting the Apple II to the Network

Step 1: Installing the Transporter Card into the Computer

First, make sure that the power is turned off for the computer.

Set the DIP Switches on the transporter card to a unique device address. (See table of network device address on page 18. DO NOT SET ADDRESS TO ZERO.)

Remove the cover from the Apple II computer.

Press the floppy drive controller card firmly into slot four of the Apple II. (See drawing next page.)

Plug the transporter card into slot six of the Apple II. (See drawing next page.)

Attach the three pronged female connector on the end of the three pronged male connector on the transporter card.

Press the floppy drive controller card firmly into slot four of the Apple II. (See drawing next page.)

Replace the cover on the Apple II.

Remember to connect the tap cable to a tap box in the trunk network for each computer.

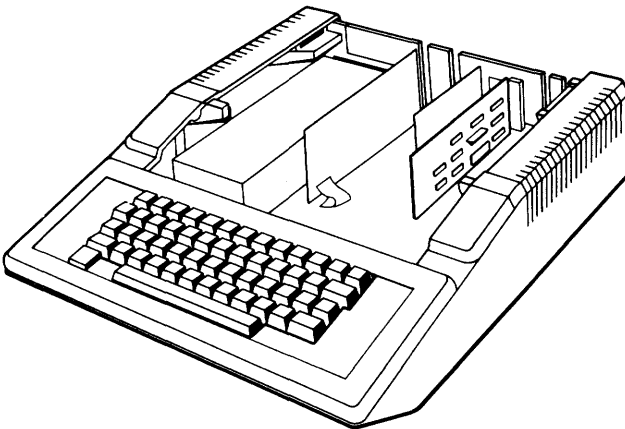

Plugging the Corvus Transporter Card into the Apple II

Address	Switch Setting					
	1	2	3	4	5	6
0	↑	↑	↑	↑	↑	↑
1	—	↑	↑	↑	↑	↑
2	↑	—	↑	↑	↑	↑
3	—	—	↑	↑	↑	↑
4	↑	↑	—	↑	↑	↑
5	—	↑	—	↑	↑	↑
6	↑	—	—	↑	↑	↑
7	—	—	—	↑	↑	↑
8	↑	↑	↑	—	↑	↑
9	—	↑	↑	—	↑	↑
10	↑	—	↑	—	↑	↑
11	—	—	↑	—	↑	↑
12	↑	↑	—	—	↑	↑
13	—	↑	—	—	↑	↑
14	↑	—	—	—	↑	↑
15	—	—	—	—	↑	↑
16	↑	↑	↑	↑	—	↑
17	—	↑	↑	↑	—	↑
18	↑	—	↑	↑	—	↑
19	—	—	↑	↑	—	↑
20	↑	↑	—	↑	—	↑
21	—	↑	—	↑	—	↑
22	↑	—	—	↑	—	↑
23	—	—	—	↑	—	↑
24	↑	↑	↑	—	—	↑
25	—	↑	↑	—	—	↑
26	↑	—	↑	—	—	↑
27	—	—	↑	—	—	↑
28	↑	↑	—	—	—	↑
29	—	↑	—	—	—	↑
30	↑	—	—	—	—	↑
31	—	—	—	—	—	↑
Address	1	2	3	4	5	6
Address	Switch Setting					

Address	Switch Setting					
	1	2	3	4	5	6
32	↑	↑	↑	↑	↑	—
33	—	↑	↑	↑	↑	—
34	↑	—	↑	↑	↑	—
35	—	—	↑	↑	↑	—
36	↑	↑	—	↑	↑	—
37	—	↑	—	↑	↑	—
38	↑	—	—	↑	↑	—
39	—	—	—	↑	↑	—
40	↑	↑	↑	—	↑	—
41	—	↑	↑	—	↑	—
42	↑	—	↑	—	↑	—
43	—	—	↑	—	↑	—
44	↑	↑	—	—	↑	—
45	—	↑	—	—	↑	—
46	↑	—	—	—	↑	—
47	—	—	—	—	↑	—
48	↑	↑	↑	↑	—	—
49	—	↑	↑	↑	—	—
50	↑	—	↑	↑	—	—
51	—	—	↑	↑	—	—
52	↑	↑	—	↑	—	—
53	—	↑	—	↑	—	—
54	↑	—	—	↑	—	—
55	—	—	—	↑	—	—
56	↑	↑	↑	—	—	—
57	—	↑	↑	—	—	—
58	↑	—	↑	—	—	—
59	—	—	↑	—	—	—
60	↑	↑	—	—	—	—
61	—	↑	—	—	—	—
62	↑	—	—	—	—	—
63	—	—	—	—	—	—
Address	1	2	3	4	5	6
Address	Switch Setting					

↑ = on
— = off

Table of Network Device Addresses

Powering on the Disk Server and Disk Drive

Step 1: Powering on the Disk Server

Connect an AC power cord first to the disk server unit, then to a power receptacle.

Power on the disk server.

Step 2: Powering on the Disk Drive

Connect an AC power cord first to the disk drive unit, then to a power receptacle.

Power on the disk drive.

Step 3: Checking for the Drive Ready Condition

In the upper right hand corner of the front of the driver there are three indicator lights labeled FAULT, BUSY and READY. When you power on the drive, all three indicator lights come on. When the drive is ready (after approximately 40 seconds), only the READY light should stay on.

If after one minute the drive does not become ready, flip the reset switch (the rightmost switch on the front of the drive) to the right. If the drive becomes ready now, continue on with the software initialization procedure.

If the drive still does not become ready, see the Troubleshooting Section of your Disk System User Guide.

You are now ready to initialize the Omninet Disk System for use.

INITIALIZING FOR APPLE BASICS (DOS 3.3)

Use the procedures in this chapter only if you are initializing your Corvus disk drive exclusively with Apple BASICS (DOS 3.3). If you are initializing for Pascal, or both Pascal and BASICS, skip this chapter and continue to Chapter 4: "Initializing for Pascal."

When you have initialized a Corvus drive with Apple BASICS, the drive is divided into multiple fixed-sized areas called volumes, each of which is equal in capacity to a diskette. Each volume stores multiple files with a file directory, and can be brought online or taken offline at will.

The procedures in this chapter will not add BASICS to a Corvus drive which has previously been initialized with Apple Pascal. Conversely, you cannot add Pascal to a drive which has been initialized using the BASICS initialization procedures in this chapter.

You may, however, initialize your drive with both Apple Pascal and Apple BASICS (DOS 3.3), using Chapter 4: "Initializing for Pascal" first, and then continuing to Chapter 5: "Adding BASICS to Pascal."

The last section of each of chapters 3, 4, and 5 describe the initialization of Constellation software for your particular operating system or systems. The Constellation software implements your Omninet network.

In this manual, reference to Apple BASICS (DOS 3.3) may be shortened, for convenience, to either BASICS or DOS.

Booting from Diskette

1. Insert the CORVUS AP UTILITIES BASICS — DOS 3.3 diskette into the diskette drive.
2. Be certain that your Corvus drive is still powered on. Power on your CRT monitor, then power on the Apple II computer.

boot diskette by typing PR#4

At this point, the Corvus disk has no information to tell the Apple how to start up (boot). Thus, the Apple must be booted from the diskette drive. To boot from the diskette, begin by holding down the [CTRL] key and pressing [RESET].

The screen displays:

]

3. The screen displays a list of some of the files, contained on the CORVUS AP UTILITIES BASICS—DOS 3.3 diskette.

VER 4.3
CORVUS AP UTILITIES FOR DOS 3.3
25-OCT-82

DISK VOLUME C01

A 003 BASICS UTILITIES 25-OCT-82
A 004 APPLESOFT BOOT PREP
B 002 BCI.OBJ
I 004 BOOT PREP
A 008 BRINGUP
A 016 BSYSGEN
B 030 BSYSGEN.OBJ
B 004 CATV99
B 042 CF18.2
B 042 CF18.2A
A 007 COPY 3
B 006 COPY3.OBJ
A 060 DIAGNOSTIC
B 004 DIAG.OBJ. 18.2
A 004 FILE FINDER
A 005 FILE MOVER
A 032 MIRROR

4. To view the rest of this list:

Press [SPACE]

The screen displays:

B 004 OMNIBCI.OBJ
A 002 PASCAL
A 015 SETBOOT
B 038 SETBOOT.OBJ31
A 003 UNLOCK VOLUME
B 003 UNLOCK VOLUME.OBJ
A 006 VOLUME INIT
A 017 VOLUME UPDATER

1

Initializing for BASICS (DOS 3.3)

1. Now that the Apple has booted from the diskette drive, run the BSYSGEN program to generate a BASICS system.

Type RUN BSYSGEN [RETURN]

The screen displays:

VER 4.6
DISK FORMATTER—3.3 BASICS ONLY

WHICH DRIVE DO YOU WANT FORMATTED FOR
"BASICS ONLY"? (1 OR 2)

2. Press 1

The screen displays:

THIS PROGRAM WILL DESTROY ANY DATA ON
DRIVE 1

OK TO BSYSGEN? (Y/N)

3. Press Y

The screen displays:

DRIVE WILL CONTAIN XX VOLUMES

LOADING BSYSGEN. OBJ---

WRITING BOOT TRACKS---

.....

ZEROING DIRECTORES---

.....
.....

4. The number of volumes shown, represented by "XX," varies according to which model drive you have. A Model 6 drive has 38 DOS volumes, and a Model 11 drive has 82 DOS volumes.

Corvus software views a Model 20 drive as two logical drives. Each drive has 62 DOS volumes.

5. Initialization takes approximately 60 seconds.

The screen displays:

FORMAT DONE
DRIVE IS FORMATTED WITH XX BASIC VOLUMES

]

The number of volumes shown, represented by "XX," varies according to which model drive you have. A Model 6 drive has 38 DOS volumes, and a Model 11 drive has 82 DOS volumes.

Corvus software views a Model 20 drive as two logical drives. Each drive has 62 DOS volumes.

6. If you have a Model 20 drive, continue to the next section, "Initializing the 2nd half of a Model 20 drive."

If you have a Model 6 or Model 11 Corvus disk drive, skip the section called "Initializing the 2nd half of a Model 20 drive" and proceed to the section titled "Installing the operating system patch."

Initializing the 2nd half of a Model 20 drive

1. Corvus software views a Model 20 drive as two logical drives. If you have a Model 20 drive, you have so far initialized only the first half of the drive. To initialize the second half of a Model 20 drive:

Type RUN BSYSGEN [RETURN]

- The screen displays:

VERSION 4.6
DISK FORMATTER—3.3 BASICS ONLY
19-JULY-81

WHICH DRIVE DO WANT FORMATTED FOR
"BASICS ONLY"? (1 OR 2)

2. Press 2

The screen displays:

THIS PROGRAM DESTROYS ANY DATA ON
DRIVE 2.

OK TO BSYSGEN? (Y/N)

3. Press Y

The screen displays:

LOADING BSYSGEN.OBJ---
WRITING BOOT TRACKS---
.....

ZEROING DIRECTORIES---
.....

FORMAT DONE
DRIVE IS FORMATTED WITH 62 BASICS VOLUMES

]

Installing the Operating System Patch

1. In order for a Corvus drive to function under Apple DOS 3.3, a patch must be installed into the operating system. To install this patch in the operating system:

Type **RUN BRINGUP [RETURN]**

The screen displays:

VER 4.1
BRINGUP UTILITY—DOS/ONLY
19-JUL-81

THIS PROGRAM IS FOR DRIVES THAT ARE DOS ONLY. IF THE DRIVE HAS BEEN FORMATTED WITH PASCAL THIS PROGRAM WILL NOT WORK PROPERLY.

CONTINUE ? (Y/N)

2. Press **Y**

The screen displays:

YOU ARE CONFIGURED AS XX VOLUMES
OF 16-SECTOR IMAGES.

CATALOG, V99, D1

The number of volumes shown, represented by "XX," varies according to the site of the drive. A Model 6 drive may have up to 38 DOS volumes, and a Model 11 drive has 82 DOS volumes.

Corvus software views a Model 20 drive as two logical drives. Each drive has 62 DOS volumes.

3. In Step 2, the screen prompts you with "CATALOG, V99, D1" to catalog the entire Corvus drive 1.

Press **[RETURN]**

The screen shows that none of the volumes on the Corvus drive contain information:

VOL DIRECTORY—CORVUS DRIVE 1

]

Type FP [RETURN]

The screen displays:

]

-
4. You will now store an image of Apple DOS 3.3 with the Corvus patch installed. This image will be used to boot up the Apple from the Corvus drive. To store this image:

Type LOAD APPLESOFT BOOT PREP [RETURN]

The screen displays:

]

-
5. **Type** CATALOG, V1, S6 [RETURN]

The screen displays:

DISK VOLUME 001

]

The screen shows that the first volume on the drive contains no information.

6. **Type** RUN [RETURN]

After a few seconds, the screen displays:

CORVUS 11A P
DOS 3.3

]

Copying BASICS Files to Hard Disk

1. Corvus utilities can be used from the hard disk once the programs are copied from the CORVUS AP Utilities diskette to the drive. To copy the Corvus utilities to the disk, begin by clearing out high memory of the Apple:

Type FP [RETURN]

The screen displays:

]

2. Type RUN COPY3.S4 [RETURN]

The screen displays:

VER 4.2
CORVUS SYSTEMS C O P Y 3
COPYRIGHT ©1979 BY PERSONAL SOFTWARE
13-MAR-81

ONLY DOS 3.3 VOLUMES CAN BE
SUCCESSFULLY COPIED

FROM SLOT (4):?

3. Press [RETURN]

The screen displays:

FROM DRIVE (1):?

4. Press [RETURN]

The screen displays:

FROM VOLUME (0):?

5. Press [RETURN]

The screen displays:

TO SLOT (6):?

6. Press [RETURN]

The screen displays:

TO DRIVE (1):?

7. Press [RETURN]

The screen displays:

TO VOLUME (1):?

8. Press [RETURN]

The screen displays:

FROM:

SLOT— 4
DRIVE— 1
VOLUME— 0

TO:

SLOT— 6
DRIVE— 1
VOLUME— 1

OK TO COPY?

9. Press Y

After about two minutes, the screen displays:

0 ERRORS DURING COPY
COPY AGAIN?

10. Press N

The screen displays:

]

Initializing Volume Directories

1. Although the BSYSGEN program initialized the entire drive, each volume directory needs to be initialized as well. To initialize volume directories:

Type RUN VOLUME INIT, S6, V1 [RETURN]

The screen displays:

VER 4.4
BULK VOLUME INITIALIZATION PROGRAM
19-JUL-81

INIITALIZES A GIVEN RANGE OF VOLUMES

WHICH DRIVE (1 OR 2)?

2. **Press 1**

The screen displays:

FIRST VOLUME (1 TO XX)?

The number of volumes shown, represented by "XX," varies according to the size of the drive. A Model 6 drive has 38 DOS volumes, and a Model 11 drive has 82 DOS volumes.

Corvus software views a Model 20 drive as two logical drives. Each drive contains 62 volumes.

3. When you used the COPY3 program, you initialized volume 1 and copied the utility diskette. Because volume 1 has already been initialized with COPY3, the first volume which still needs to be initialized is volume 2.

Press 2 [RETURN]

The screen displays:

LAST VOLUME (2 TO XX)?

The number of volumes shown, represented by "XX," varies according to the size of the drive. A Model 6 drive

has 38 DOS volumes, a Model 11 drive has 82 DOS volumes, and either half of a Model 20 drive has 62 volumes.

4. Enter the appropriate number of volumes for your model or disk drive and **press** [RETURN].

For a Model 6 drive:

Type 37 [RETURN]

For a Model 11 drive:

Type 82 [RETURN]

For either half of a Model 20 drive:

Type 62 [RETURN]

The screen displays:

INITIALIZE VOLUMES 2 THRU XX ON DRIVE 1
ARE YOUR SURE?

5. **Press** Y

The screen displays:

VOLUME X INITIALIZED
INITIALIZING VOLUME Y.

As each of the volumes is initialized, the displayed volumes (represented here as X and Y) change on the screen. Finally, when all volumes have been initialized, the screen displays:

VOLUMES 2 THRU XX ARE INITIALIZED

]

The "XX" in the above example should be the same as the number of volumes you entered in Step 4.

6. If you have a Model 6 or Model 11 Corvus drive, your drive is now configured for BASICS (Apple DOS 3.3) only; skip Steps 7-11, and continue to Step 12.

If you have a Model 20 drive, continue with Steps 7-11 to initialize the volume directory on the second half of the Model 20 drive.

7. To initialize the volume directory on the second half of a Model 20 drive:

Type RUN VOLUME INIT,S6,V1 [RETURN]

The screen displays:

VER 4.4
BULK VOLUME INITIALIZATION PROGRAM
19-JUL-81

INITIALIZES A GIVEN RANGE OF VOLUMES

WHICH DRIVE (1 OR 2)?

8. Press 2

The screen displays:

FIRST VOLUME (1 TO 62)?

9. Press 1 [RETURN]

The screen displays:

LAST VOLUME (2 TO 67)?

10. Type 62 [RETURN]

The screen displays:

INITIALIZE VOLUMES 2 THRU 62 ON DRIVE 2
ARE YOU SURE?

11. Press Y

After initializing each volume, the screen displays:

VOLUMES 2 THRU 62 ARE INITIALIZED

12. After you have initialized all volume directories, your Corvus drive is configured for BASICS (Apple DOS 3.3) only. Do NOT attempt to add Pascal to a Corvus disk drive which has been initialized for Apple DOS only.

To gain familiarity with your Corvus disk system and related software, continue to the CORVUS DISK SYSTEM USER GUIDE FOR APPLE II COMPUTERS. The User's Guide can also be used to add more Corvus disk drives to your system.

To supervise a multi-user network of Apple II computers and Corvus disks, see the CORVUS SYSTEM MANAGER'S GUIDE FOR APPLE II COMPUTERS.

Upgrading BASICS with Constellation Software

In this section you will bring up a BASICS only system with Constellation software for the Model 6, 11, or 20 drives. The following will contain a step by step guide allowing you to add multi-user Constellation network capability to an Apple II computer. If you want a system with both BASICS and Pascal, then begin with "UPGRADING PASCAL WITH CONSTELLATION SOFTWARE."

The Constellation software can be installed on an existing single user Corvus system, with Apple BASICS, without deleting any existing volumes.

Because of the varying amount of data space available on the Corvus Model 6, 11, and 20 drives, some of your responses to the prompts in the programs in this section may not be the ones shown. The table below shows the various amounts.

Drive	Blocks Available	Maximum Volumes
6	11540	38
11	23700	82
20	35860	124

(62 per logical drive)

ONLY THE FIRST TWO DRIVES OF A CORVUS DISK SYSTEM CAN HAVE BASICS VOLUMES ON THEM.

Copying Constellation Files to the Hard Disk

The first task in upgrading your system is to connect the proper hardware and move the files from the floppy diskette to the Winchester drive.

The diskette will be copied to drive 1, volume 2 on the Corvus disk. Therefore, remove any valuable files from that volume before continuing with this procedure.

1. Power on the Apple II. The Apple will boot the first volume on the Corvus drive.

The screen displays:

```
-----  
CORVUS 11AP  
DOS 3.3  
-----  
  
]
```

2. Place the Corvus Constellation AP Utilities BASICS—DOS 3.3 diskette on the Apple II floppy drive.
3. **Type** RUN COPY3,S6,V1,D1 [RETURN]

The screen displays:

```
-----  
VER 4.2  
CORVUS SYSTEMS COPY3  
COPYRIGHT ©1979 BY PERSONAL SOFTWARE  
13-MAR-81  
  
ONLY DOS 3.3 VOLUMES CAN BE  
SUCCESSFULLY COPIED  
  
FROM SLOT (4) :?
```

4. **Press** [RETURN]

The screen displays:

```
-----  
FROM DRIVE (1) :?  
-----
```

5. Press [RETURN]

The screen displays:

FROM VOLUME (0) :?

6. Press [RETURN]

The screen displays:

TO SLOT (6) :?

7. Press [RETURN]

The screen displays:

TO DRIVE (1) :?

8. Press [RETURN]

The screen displays:

TO VOLUME (1) :?

9. Press 2 [RETURN]

The screen displays:

FROM
 SLOT— 4
 DRIVE— 1
 VOLUME— 0

TO
 SLOT— 6
 DRIVE— 1
 VOLUME— 2

OK TO COPY ?

10. Press Y

After approximately one minute, the screen displays:

0 ERRORS DURING COPY
COPY AGAIN?

11. Press N

The screen displays:

]

12. Type FP [RETURN]

The screen displays:

]

Initializing with CONSTCREATE

To generate a Constellation system, begin by running the CONSTCREATE program.

1. Type RUN CONSTCREATE,S6,V2 [RETURN]

The screen displays:

VER 4.2
CONSTELLATION VOLUME PREP
08-APR-81

THIS PROGRAM WILL MAKE A GROUP OF
BASICS VOLUMES PROTECTED AGAINST
ALL CONSTELLATION USERS EXCEPT
USER NUMBER ONE, WHO WILL BE GIVEN
WRITE ACCESS TO ALL VOLUMES

CONTINUE (Y/N) ?

2. Press Y

The screen displays:

DRIVE (1 OR 2) :

3. Press 1

The screen displays:

STARTING VOLUME (1..XX) :

The number of volumes (represented above by XX) vary according to drive model.

4. Press 1 [RETURN]

The screen displays:

ENDING VOLUME (1..XX) :

5. Enter the number of the last volume which will fit on your disk drive.

For example, for a Model 6 drive:

Type 37 [RETURN]

The screen displays:

CONST PREP VOLS 1 THRU XX ON DRIVE 1
ARE YOUR SURE?

6. Press Y

The screen displays:

INITIALIZING VOLUMES..

The screen displays a dot as each volume is initialized for use with Constellation software and then reports:

END OF PROGRAM

Initializing for a Model 20 Drive

If you have a Model 6 or 11 drive skip to the next section, "Setting Boot to Constellation." If you have a Model 20 drive, the CONSTCREATE program must be repeated to initialize the volumes on the second logical drive for use with Constellation software.

1. Type RUN CONSTCREATE,S6,V2 [RETURN]

The screen displays:

VER 4.2
CONSTELLATION VOLUME PREP
08-APR-81

THIS PROGRAM WILL MAKE A GROUP OF
BASICS VOLUMES PROTECTED AGAINST
ALL CONSTELLATION USERS EXCEPT
USER NUMBER ONE, WHO WILL BE GIVEN
WRITE ACCESS TO ALL VOLUMES.

CONTINUE (Y/N) ?

2. Press Y

The screen displays:

DRIVE (1 OR 2) :

3. Press 2

The screen displays:

STARTING VOLUME (1..62) :

4. Press 1 [RETURN]

The screen displays:

ENDING VOLUME (1..62) :

5. Type 62 [RETURN]

The screen displays:

CONST PREP VOLS 1 THRU 62 ON DRIVE 2
ARE YOU SURE?

6. Press Y

The screen displays:

INITIALIZING VOLUMES...

The screen displays a dot as each of the 62 volumes is initialized for use with Constellation software.

END OF PROGRAM

]

Setting Boot to Constellation

When a single computer system without Constellation software boots, the user has access to the entire drive. To require the entry of a log-on name to boot, you must run the SETBOOT program.

1. Type RUN SETBOOT,V1S6 [RETURN]

The screen displays:

VER 4.5
CORVUS BOOT SELECTION PROGRAM
9-SEP-81

P[ASCAL B[ASICS C[ONST Q:

2. Press C

The screen displays:

LOADING SETBOOT.OBJ.....
SETTING BOOT FOR PASCAL VERSION 1.0--
CORVUS BOOT NOW SET UP TO CONSTELLATION

]

Initialize User Table

The program USER MANAGER will initialize the table in which the names of system users will be stored.

1. Type RUN USER MANAGER,V2,S6,D1 [RETURN]

The screen displays:

```

VER. 4.4
USER MANAGER
27-JUL-81

```

```

QUIT Z(EROUSERS L(IST A(DD R(EMOVE :

```

2. Press Z

The screen displays:

```

*****
ZEROING THE USER TABLE WILL
REMOVE ALL VALID USERS. YOU
*MUST* ADD SOME VALID USERS
BEFORE ENDING THIS PROGRAM OR
IT WILL BE IMPOSSIBLE TO BOOT
THE CONSTELLATION SYSTEM.
*****

```

```

CONTINUE Y/N ?

```

3. Press Y

The screen displays:

```

.....
.....

```

4. Type SMOR [RETURN]

The screen displays:

```

ENTER PASSWORD (2 CHARS MAX)
OR TYPE [RETURN] FOR NO PASSWORD :

```

5. Press [RETURN]

The screen displays:

```

ENTER BASICS HOME VOLUME (0..XX) :

```

6. Type 1 [RETURN]

The screen displays:

```
*****
THE VOLUME MUST BE A 3.3 MASTER

USE 'VOLUME UPDATER' TO FETCH A 3.3
IMAGE FROM AN APPLE DOS 3.3
SYSTEM MASTER DISKETTE
*****
```

```
DEFAULT : P(ASCAL OR B(BASICS ?
```

7. Press B

The screen displays:

```
Q(UIT Z(EROUERS L(IST A(DD R(EMOVE :
USER HAS BEEN ADDED.
```

8. Press L

The screen displays:

```
*** Constellation USER DIRECTORY ***
ID: 1 SMOR [ ] (BASICS) VOL: 1
```

```
Q(UIT Z(EROUERS L(IST A(DD R(EMOVE
```

9. Press Q

The screen displays:

```
END OF PROGRAM
]
```

Ensure that volume 1 contains a DOS 3.3 master image. If it contains the Corvus AP Utilities, it is OK.

Reboot

The system is now upgraded to Constellation software. To test it you may boot the system to the new Constellation software.

1. Type PR#6 [RETURN]

The screen displays:

C O R V U S
C O N S T E L L A T I O N

✧
✧
✧ ✧
✧

PLEASE ENTER YOUR NAME __

2. Type SMGR [RETURN]

The screen displays the catalog of the first volume on the Corvus hard disk. To view the remainder of the directory:

3. Press [SPACE]

The BASICS only disk system has now been ungraded for use with Constellation software. Proceed to the SYSTEM MANAGER'S GUIDE FOR APPLE II COMPUTERS for details on the Constellation software.

INITIALIZING FOR PASCAL

The procedures in this chapter initialize your Corvus disk drive with Apple Pascal. After you complete this chapter, you can leave your drive with Pascal only, or you can add Apple BASICS (DOS 3.3) to Pascal by continuing to Chapter 5.

When you have initialized a Corvus drive with Apple Pascal, the drive is divided into variable-sized areas called volumes. Each volume is similar to a floppy, in that it can store multiple files with a file directory, and can be brought online or taken offline at will. But Corvus volumes can be as large as 10 megabytes.

Booting from Diskette

- 1.** With the Apple II powered off, remove the cover from the Apple II computer.
- 2.** Remove the Corvus interface card from slot six and the floppy drive controller card from slot four of the Apple II.
- 3.** Press the Corvus interface card firmly into slot two of the Apple II computer.
- 4.** Press the diskette controller card firmly into slot six of the Apple II.
- 5.** Replace the cover of the Apple II computer.
- 6.** Make sure you have all of the Apple Pascal system diskettes, both of the Corvus Pascal Utilities diskettes (volumes 1 and 2), and a blank diskette which has been formatted with the FORMATTER program on the Apple Pascal APPLE3 diskette.
- 7.** Place the Apple Pascal APPLE 1 system diskette in the diskette drive.

8. Power on the CRT monitor, then the Apple II computer.

The screen displays:

COMMAND: E[DIT R[UN F[ILE C[OMP L[IN

WELCOME APPLE1 TO APPLE II PASCAL 1.1

BASED ON UCSD PASCAL II.1

CURRENT DATE IS 14-AUG-80

©Apple Computer Inc. 1979, 1980

©UC Regents 1979

NOTE: Only the portion of the Pascal command line which appears on a 40-column monitor is shown above. The full Pascal command line only becomes visible on an 80-column monitor, and looks like this:

COMMAND: E[DIT R[UN F[ILE C[OMP L[INK X[ECUTE A[SSEM D[EBUG ? [1.1]

Creating the SYS: diskette

- 1.** Before you can initialize a Corvus drive for Pascal, a Pascal disk initialization diskette must be produced. This System Bringup (or SYS: for short) diskette will contain selected Corvus utility files for initializing a Corvus drive, and certain Apple Pascal files which enable the Apple II to boot up in Pascal from this SYS: diskette.

To produce this system bringup diskette, begin by selecting the Pascal filer. The Apple Pascal APPLE1 diskette should still be in the diskette drive.

Press F

The screen displays:

FILER: G, S, N, L, R, C, T, D, Q [1.1]

- 2.** To transfer files from the Apple Pascal APPLE1 diskette to the blank diskette:

Press T

The screen displays:

TRANSFER ?

3. Type APPLE1:;BLANK: [RETURN]

This command tells the Apple II to copy the entire contents of the APPLE1: diskette to the BLANK: diskette, including the APPLE1: diskette's name.

The screen displays:

TRANSFER 280 BLOCKS ? (Y/N)

4. Press Y

The screen displays:

PUT IN BLANK:
TYPE [SPACE] TO CONTINUE

5. Place the formatted BLANK: diskette in the diskette drive.

6. Press [SPACE]

The screen displays:

DESTROY BLANK: ?

7. Press Y

The screen displays:

PUT APPLE1: IN UNIT #4
TYPE [SPACE] TO CONTINUE

8. Place the APPLE1: diskette in the diskette drive.

9. Press [SPACE]

10. Swap the APPLE1: and BLANK: diskettes, following the instructions that display on the screen, until the contents of the APPLE1: diskette have been copied to the BLANK: diskette.

When this transfer has been completed, the BLANK: diskette should be in the diskette drive.

The screen displays:

```
FILER: G, S, N, L, R, C, T, D, Q [1.1]
APPLE1:                               --▶BLANK:
```

- 11.** At this point, the BLANK: diskette has been renamed the APPLE1: diskette. However, this diskette should be renamed SYS: for use with a Corvus drive. To change the name of the diskette:

Press C

The screen displays:

```
CHANGE?
```

- 12.** Type APPLE1:;SYS:

Press [RETURN]

The screen displays:

```
FILER: G, S, N, L, R, C, T, D, Q [1.1]
APPLE1:                               --▶SYS:
```

The BLANK: diskette, which had previously been renamed APPLE1:, has again been renamed. It will be referred to as the SYS: diskette for the rest of this chapter.

- 13.** Now copy a few files from the Corvus Pascal Utilities diskettes onto the SYS: diskette. Begin by placing the CORVUS AP UTILITIES—VOL. 1 OF 2 PASCAL 1.1 diskette in the diskette drive.

- 14.** Press T

The screen displays:

```
TRANSFER ?
```

- 15.** Type CORVUS1: BOOT.DATA,SYS:\$ [RETURN]

The screen displays:

```
PUT IN SYS:
TYPE [SPACE] TO CONTINUE
```

- 16.** Place the SYS: diskette in the diskette drive.

17. Press [SPACE]

The screen displays:

FILER: G, S, N, L, R, C, T, D, Q [1.1]

CORVUS1:BOOT.DATA
--▶ SYS:BOOT.DATA

18. Place the CORVUS AP UTILITIES—VOL 1 OF 2 PASCAL 1.1 diskette in the diskette drive.

19. Press T

The screen displays:

TRANSFER ?

20. Type CORVUS1:PSYSGEN.CODE.SYS:\$ [RETURN]

The screen displays:

PUT IN SYS:
TYPE [SPACE] TO CONTINUE

21. Place the SYS: diskette in the diskette drive.

22. Press [SPACE]

The screen displays:

FILER: G, S, N, L, R, C, T, D, Q [1.1]

CORVUS1:PSYSGEN.CODE
--▶ SYS:PSYSGEN.CODE

23. Place the CORVUS AP UTILITIES—VOL. 1 OF 2 PASCAL 1.1 diskette in the diskette drive.

24. Press T

The screen displays:

TRANSFER ?

25. Type CORVUS1:DIAG.DATA,SYS:\$ [RETURN]

The screen displays:

```
PUT IN SYS:
TYPE [SPACE] TO CONTINUE
```

26. Place the SYS: diskette in the diskette drive.

27. Press [SPACE]

The screen displays:

```
FILER: G, S, N, L, R, C, T, D, Q, [1.1]

CORVUS1:DIAG.DATA
--▶ SYS:DIAG.DATA
```

28. To check that all software was successfully copied from the original Apple and Corvus diskettes to the SYS: diskette:

Press E

The screen displays:

```
DIR LISTING OF ?
```

29. Type SYS: [RETURN]

The screen displays:

```
FILER: G, S, N, L, R, C, T, D, Q [1.1]
SYS:
SYSTEM.APPLE          32    9-NOV-80    6  DATA
SYSTEM.PASCAL         41   22-SEP-80   38  CODE
SYSTEM.MISCINFO       1    4-MAY-79   79  DATA
SYSTEM.EDITOR         47   24-SEP-80   80  CODE
SYSTEM.FILER          28   18-SEP-80  127  CODE
SYSTEM.LIBRARY        31   20-JAN-81  155  DATA
SYSTEM.CHARSET         2   14-JUN-79  189  DATA
SYSTEM.SYNTAX         14    1-AUG-80  191  DATA
PSYSGEN.CODE         20   21-OCT-82  223  CODE
DIAG.DATA             1    19-SEP-81  225  DATA
BOOT.DATA            18    1-SEP-81  226  DATA
[UNUSED]              36                                244
11/11 FILES, 36 UNUSED, 36 IN LARGEST
```

- 30.** If one or more of the above files are not listed on your screen, use the **T(RANSFER** option of the Pascal filer to copy the missing files onto the **SYS:** diskette.

When all of the above files have been copied onto the **SYS:** diskette, exit the filer:

Press Q

The screen displays:

```
COMMAND: E(DIT R(UN F(ILE C(OMP L(IN
```

Initializing for Pascal

The Corvus drive will now be initialized for Pascal. A 1024-block volume called **SYS:** will be created on the hard disk. The entire contents of the **SYS:** diskette will be copied to the **SYS:** volume, allowing the Apple II to boot from the Corvus drive.

- 1.** Be sure that the diskette named **SYS:** is still in the diskette drive and the Apple II is still powered on.

Press X

The screen displays:

```
EXECUTE WHAT FILE ?
```

- 2. Type PSYSGEN [RETURN]**

The screen displays:

```
PSYSGEN UTILITY...VERSION 2.7
```

```
OK TO DESTROY ALL DATA  
ON DISC IN ALTERNATE SLOT (Y/N)?
```

- 3. Press Y**

The screen displays:

```
OPENING FILE BOOT.DATA...  
WRITING BOOT TRACKS...  
SETTING BOOT FOR PASCAL 1.1  
COPYING FLOPPY TO DISC...  
.....  
PSYSGEN OPERATION FINISHED
```

4. Remove the SYS: diskette from the diskette drive.
5. Power off the Apple II computer.
6. Remove the Corvus interface card from slot 2 of your Apple II computer, and the diskette controller card from slot 6.
7. Press the Corvus interface card firmly into slot 6 of the Apple. Press the diskette controller card firmly into slot 4.
8. Power on the Apple II computer. If disk initialization was successful, the screen will display:

COMMAND: E[DIT R[UN F[ILE C[OMP L[IN

WELCOME SYS, TO APPLE II PASCAL 1.1.

BASED ON UCSD PASCAL II.1

CURRENT DATE IS 14-AUG-80

©APPLE COMPUTER INC. 1979, 1980

©U.C. REGENTS 1979

If the Apple did not boot from the Corvus drive, repeat Steps 1-8. When the Apple has booted, continue to the next section, "Copying Pascal Files to Hard Disk."

Copying Pascal Files to the Hard Disk

1. After you have initialized your Corvus drive with Apple Pascal, copy certain Pascal files from diskettes into the SYS: volume of the Corvus drive.

Place the CORVUS AP UTILITIES—VOL. 1 OF 2 PASCAL 1.1 diskette in the diskette drive.

2. To copy all files from the CORVUS1: diskette to the SYS: volume of the hard disk, begin by entering the Pascal filer:

Press F

The screen displays:

FILER: G, S, N, L, R, C, T, D, Q [1.1]

3. Press T

The screen displays:

```
TRANSFER ?
```

4. Type CORVUS1:,SYS:\$ [RETURN]

This command tells the Apple II to copy all files from the CORVUS1: diskette to the SYS: volume on the Corvus drive.

The screen displays:

```
CORVUS1:BASICS.CODE  
--▶ SYS: BASICS.CODE  
REMOVE OLD SYS: BOOT.DATA ?
```

5. Press N

The screen displays:

```
CORVUS1:CF18.2.DATA  
--▶ SYS:CF18.2.DATA  
CORVUS1:DIAGNOSTIC.CODE  
--▶ SYS:DIAGNOSTIC.CODE  
REMOVE OLD SYS:DIAG.DATA ?
```

6. Press N

The screen displays:

```
CORVUS1:MIRROR.CODE  
--▶ SYS:MIRROR.CODE  
REMOVE OLD PSYSGEN.CODE ?
```

7. Press N

The screen displays:

```
CORVUS1:SETBOOT.CODE  
--▶ SYS:SETBOOT.CODE  
CORVUS1:VMGR.CODE  
--▶ SYS:VMGR.CODE
```

When all files have been copied, the screen displays:

```
FILER: G, S, N, L, R, C, T, D, Q [1.1]
```

8. Place the CORVUS AP UTILITIES—VOL. 2 OF 2 PASCAL 1.1 diskette in the diskette drive.

9. Press T

The screen displays:

TRANSFER ?

10. To copy all files from the CORVUS2: diskette to the SYS: volume on the Corvus drive:

Type CORVUS2:,SYS:\$ [RETURN]

The screen displays:

FILER: G, S, N, L, R, C, T, D, Q, [1.1]

CORVUS2:BACKUP.CODE
--▶ SYS:BACKUP.CODE
CORVUS2:BASICS3.DATA
--▶ SYS:BASICS3.DATA
CORVUS2:BASICS3.OMNI
--▶ SYS:BASICS3.OMNI
CORVUS2:RESTORE.CODE
--▶ SYS:RESTORE.CODE
CORVUS2:VINIT.CODE
--▶ SYS:VINIT.CODE

11. Place the Apple Pascal APPLE2 diskette in the diskette drive.

12. Press T

The screen displays:

TRANSFER ?

13. To copy all files from the APPLE2: diskette to the SYS: volume of the hard disk:

Type APPLE2:,SYS:\$ [RETURN]

The screen displays:

```
FILER: G, S, N, L, R, C, T, D, Q [1.1]
```

```
APPLE2:SYSTEM.COMPILER
--▶ SYS:SYSTEM.COMPILER
APPLE2:SYSTEM.LINKER
--▶ SYS:SYSTEM.LINKER
APPLE2:SYSTEM.ASSMBLER
--▶ SYS:SYSTEM.ASSMBLER
APPLE2:6500.OPCODES
--▶ SYS: 6500.OPCODES
APPLE2:6500.ERRORS
--▶ SYS:6500.ERRORS
```

- 14.** The Apple Pascal APPLE3 diskette includes two files for formatting floppy diskettes. Both files should be copied to the Corvus drive. Begin by placing the Apple Pascal APPLE3 diskette in the diskette drive.

15. Press T

The screen displays:

```
TRANSFER ?
```

- 16. Type APPLE3:FORMATTER.CODE,SYS:\$ [RETURN]**

The screen displays:

```
FILER: G, S, N, L, R, C, T, D, Q [1.1]
```

```
APPLE3:FORMATTER.CODE
--▶ SYS:FORMATTER.CODE
```

17. Press T

The screen displays:

```
TRANSFER ?
```

18. Type APPLE3:FORMATTER.DATA,SYS:\$ [RETURN]

The screen displays:

FILER: G, S, N, L, R, C, T, D, Q [1.1]

APPLE3:FORMATTER.DATA
▶ SYS:FORMATTER.DATA

19. The SYS: volume on the Corvus drive now contains all of the Corvus single-user utilities and most of the Pascal language system. To view a list of the files in the SYS: volume:

Press E

The screen displays:

DIR LISTING OF ?

20. Type SYS: [RETURN]

The screen displays:

TYPE [SPACE] TO CONTINUE

SYS:

SYSTEM.APPLE	32	9-NOV-80	6 DATA
SYSTEM.PASCAL	41	22-SEP-80	38 CODE
SYSTEM.MISCINFO	1	4-MAY-70	79 DATA
SYSTEM.EDITOR	47	24-SEP-80	80 CODE
SYSTEM.FILER	28	18-SEP-80	127 CODE
SYSTEM.LIBRARY	34	19-SEP-81	155 DATA
SYSTEM.CHARSET	2	14-JUN-79	189 DATA
SYSTEM.SYNTAX	14	1-AUG-80	191 DATA
BOOT.DATA	18	1-SEP-81	205 DATA
PSYSGEN.CODE	20	1-SEP-81	223 CODE
DIAG.DATA	1	31-AUG-81	243 DATA
BASICS.CODE	2	26-FEB-81	244 CODE
CF17.3.DATA	60	9-NOV-81	246 DATA
DIAGNOSTIC.CODE	49	4-DEC-81	306 CODE
MIRROR.CODE	50	12-AUG-81	355 CODE
SETBOOT.CODE	18	12-AUG-81	405 CODE
VMGR.CODE	48	12-AUG-81	423 CODE
BACKUP.CODE	4	13-SEP-70	471 CODE
BASICS3.DATA	96	28-OCT-80	475 DATA
BASICS3.OMNI	96	31-JUL-81	571 DATA
RESTORE.CODE	4	5-OCT-79	667 CODE
INIT.CODE	52	20-AUG-81	671 CODE

- 21.** The above is a partial list of the files in the SYS: volume of the Corvus drive. To view the rest of the list:

Press [SPACE]

The screen displays:

```
FILER: G, S, N, L, R, C, T, D, Q [1.1]
SYS:
SYSTEM.COMPILER      75  19-SEP-80   723  CODE
SYSTEM.LINKER        24  16-SEP-80   798  CODE
SYSTEM.ASSMBLER      54  19-SEP-80   822  CODE
6500.OPCODES         2  20-DEC-78   876  DATA
6500.ERRORS          7  28-MAR-79   878  DATA
FORMATTER.CODE       4  14-AUG-80   885  CODE
FORMATTER.DATA       6  14-AUG-80   889  DATA
[UNUSED]              129
29/29 files, 129 unused, 129 in largest
```

- 22.** When all of the desired files have been copied to the SYS: volume, exit the filer:

Press Q

The screen displays:

```
COMMAND: E[DIT R[UN F[ILE C[OMP L[IN
```

- 23.** If you are initializing a Model 20 drive, continue with the next section, "Initializing the 2nd half of a Model 20 drive."

If you are configuring a Model 6 or Model 11 drive for Pascal only, your system is configured.

To add BASICS to Pascal on a Model 6 or Model 11 drive, skip the next section titled "Initializing the 2nd half of a Model 20 drive," and continue to Chapter 5: "Adding BASICS to Pascal."

To gain familiarity with your Corvus disk system and related Pascal software, continue to the CORVUS DISK SYSTEM USER'S GUIDE FOR APPLE II COMPUTERS. The User's Guide can also be used to add more Corvus disk drives to your system.

To supervise a multi-user network of Apple II computers and Corvus disks, see the CORVUS SYSTEM MANAGER'S GUIDE FOR APPLE II COMPUTERS.

Initializing the 2nd Half of a Model 20 Drive

1. To initialize the second half of a Model 20 drive:

Press X

The screen displays:

EXECUTE WHAT FILE?

2. Type VINIT [RETURN]

The screen displays:

VINIT: I(NIT D(OSVOL C(ONST S(EM P(IPES

3. Press I

The screen displays:

INITIALIZE VOLUME DIRECTORY OF DRIVE # :

4. Press 2 [RETURN]

When the volume directory has been initialized, the screen displays:

COMMAND: E(DIT R(UN F(ILE C(OMP L(IN

5. Press Q

6. If you are configuring a Model 20 drive for Pascal only, your system is initialized.

If you wish to add BASICS to Pascal on your Model 20 drive, continue to Chapter 5: "Adding BASICS to Pascal."

To gain familiarity with your Corvus disk system and related software, continue to the CORVUS DISK SYSTEM USER'S GUIDE FOR APPLE II COMPUTERS. The User's Guide can also be used to add more Corvus disk drives to your system.

To supervise a multi-user network of Apple II computers and Corvus disks, see the CORVUS SYSTEM MANAGER'S GUIDE FOR APPLE II COMPUTERS.

Upgrading Pascal with Constellation Software

This section covers bringing up a Pascal system or the Pascal section of a Pascal-BASICS system for use with Constellation software for Model 6, 11, or 20 drives.

The Constellation software may be installed on an existing single user Corvus system, with Apple Pascal, without deleting any existing user files.

Create Volume—Private

To upgrade a Pascal system with Constellation software, begin by creating a volume named PRIVATE:. The volume PRIVATE: will be used only by the system manager, who will have sole access to the volume.

1. Power up the system.

The screen displays:

```
COMMAND: E{DIT, R{UN, F{ILE, C{OMP, L{IN
```

2. Press X

The screen displays:

```
EXECUTE WHAT FILE?
```

3. Type VMGR [RETURN]

The screen displays:

```
VMGR: Q L{IST N{EW R{MOVE W{PROT M{NT U{NM
```

4. Press N

The screen displays:

```
NEWVOLUME: ENTER VOLUME NAME :
```

5. Type PRIVATE [RETURN]

The screen displays:

```
ENTER LENGTH (BLOCKS) :1024
```

6. Type 512 [RETURN]

The screen displays:

ENTER CORVUS DRIVE # (1..2) :1

7. Press [RETURN]

The screen displays:

ENTER ADDRESS (BLOCKS):XX

8. Press [RETURN]

The volume is added and the screen displays:

VMGR: Q L{IST N{EW R{MOVE.W{PROT M{NT U{NM

9. Press M

The screen displays:

MOUNT : ENTER VOLUME NAME :

10. Type PRIVATE [RETURN]

The screen displays:

MOUNT PRIVATE ON UNIT #9

11. Type 12 [RETURN]

The screen displays:

PRIVATE : MOUNTED

You have now created and mounted a volume named PRIVATE:. This volume will be used to store programs for use by the system manager only.

12. Quit the VMGR program.

Press Q

The screen displays:

CHANGE DEFAULT MOUNT TABLE (Y/N):

13. Press Y

The screen displays:

```
COMMAND: E(DIT, R(UN, F(ILE, C(OMP, L(IN
```

File Transfer

In this section you will transfer the files you need from the floppy diskette to volumes SYS: and PRIVATE:. These files are the new Constellation software programming that will upgrade a single user system to multi-user capability.

The following steps should be followed to transfer the files to the proper volume.

1. Press F

The screen displays:

```
FILER: G, S, N, L, R, C, T, D, Q [1.1]
```

2. Press C

The screen displays:

```
CHANGE ?
```

3. Press T

The screen displays:

```
TRANSFER ?
```

4. Type #4:?,#12:\$ [RETURN]

The screen will display each file one at a time.

5. Press Y for the files listed below and Press N for all other files.

```
PSYSGEN.CODE  
DIAG.DATA  
CF18.3.DATA  
DIAGNOSTIC.CODE  
SETBOOT.CODE  
BACKUP.CODE  
RESTORE.CODE  
VINIT.CODE
```

6. Press R

The screen displays:

REMOVE WHAT FILE ?

7. Type SYS:? [RETURN]

The screen will display each file one at a time.

**8. Press Y for the files listed below and
Press N for all other files:**

PSYSGEN.CODE *psysgen.code*
DIAG.DATA
CF18.3.DAT
DIAGNOSTIC.CODE
SETBOOT.CODE
BACKUP.CODE
RESTORE.CODE
VINIT.CODE

9. When asked "UPDATE DIRECTORY"

Press Y

10. Press K

The screen displays:

CRUNCH ?

11. Type SYS: [RETURN]

The screen displays:

FROM END OF DISK, BLOC 1024/ [Y/N]

12. Press Y

The screen shows the moving of various files.

The screen then displays:

SYS: CRUNCHED

**13. Place the Corvus Constellation Utilities—Pascal 1.1 diskette
in the floppy drive.**

14. Press T

The screen displays:

TRANSFER ?

15. Type #9:?,SYS:\$ [RETURN]

The screen will display each file one at a time.

**16. Press Y for the files listed below and
Press N for all other files.**

CORVUS.LIBRARY
SHARE.TEXT
SHARE.CODE
SPOOL.TEXT
SPOOL.CODE
USERDEMO.TEXT
USERDEMO.CODE

17. When asked "UPDATE DIRECTORY"

Press Y

18. Press T

The screen displays:

TRANSFER ?

19. Type #9:?,PRIVATE:\$ [RETURN]

The screen will display each file one at a time.

**20. Press Y for the files listed below and
Press N for all other files.**

CMGR.CODE
SETBOOT.CODE

21. When asked "UPDATE DIRECTORY"

Press Y

22. Press Q

The screen displays:

COMMAND: E(DIT, R(UN, F(ILE, C(OMP, L(IN

You have now transferred all the Pascal files from the floppy to volumes SYS: and PRIVATE: on the Corvus hard disk.

Volume Initialization

This section will initialize (set up) a Pascal system for use with Constellation software. There must be at least 126 contiguous free blocks in the default volume when this option is run.

1. Press X

The screen displays:

EXECUTE WHAT FILE ?

2. Type PRIVATE:VINIT [RETURN]

The screen displays:

VINIT: I(NIT D(OSVOL C(ONST S(EM4INIT P(IPES

3. Press C

If a Model 20 drive is being used, the screen displays:

WHICH DRIVE SHOULD BE SET UP (1..2)? 1

4. Press [RETURN]

The screen displays:

THIS PROGRAM WILL
--GIVE THE USER WHOSE ID IS #1 FULL ACCESS TO
THE SYSTEM
--SET ITS ID TO SMGR WITH NO PASSWORD
--GIVE ALL OTHER USERS NO PASCAL ACCESS
THE FMGR P(PREFIX MUST BE SET TO THE FIRST
VOLUME ON THE CORVUS DRIVE (1..X)

CONTINUE (Y/N) ?

5. Press Y

The screen displays:

```

.....
.....
.....
DONE THE CONSTELLATION USER TABLE IS NOW
INITIALIZED CONFIRM ZERO USER TABLE: N

```

6. Press Y

The screen displays:

```

.....
.....
.....
.....

```

7. Press Q

The screen displays:

```

COMMAND: E[DIT, R[UN, F[ILE, C[OMP, L[IN

```

Volume Initialization for a Model 20 Drive

If you have a Model 6 or 11 drive go to the next section titled "Setting Boot to Constellation." If you have a Model 20 drive proceed with this section. This section creates the first volume for the second half of your drive.

1. A small volume (136 blocks) must be created at block 8 on logical drive 2 of a Model 20 drive. If a volume presently exists at this location, save the volume's data and then remove the volume.

2. Press X

The screen displays:

```

EXECUTE WHAT FILE?

```

3. Type VMGR [RETURN]

The screen displays:

```

EXECUTE WHAT FILE?

```

4. Press N

The screen displays:

NEW VOLUME 2 ERROR 1754 12 15
VMGR: Q L(IST N(EW R(MVE W(PROT M(NT U(NM

5. Type SYS2: [RETURN]

The screen displays:

ENTER LENGTH

6. Type 136 [RETURN]

The screen displays:

ENTER CORVUS DRIVE #(1..2)

7. Type 2 [RETURN]

The screen displays:

ENTER ADDRESS (BLOCKS):

8. Type 8 [RETURN]

The volume is added and the screen displays:

VMGR: Q L(IST N(EW R(MVE W(PROT M(NT U(NM

9. Press M

The screen displays:

MOUNT: ENTER VOLUME NAME

10. Type SYS2: [RETURN]

The screen displays:

MOUNT SYS2: ON UNIT #

11. Type 10 [RETURN]

The screen displays:

SYS2: MOUNTED

12. Press Q

The screen displays:

CHANGE DEFAULT MOUNT TABLE (Y/N):

13. Press Y

The screen displays:

COMMAND: E{DIT, R{UN, F{ILE, C{OMP, L{IN

14. Press F

The screen displays:

FILER: G, S, N, L, R, C, T, D, Q [1.1]__

15. Press P

The screen displays:

PREFIX TITLES BY ?

16. Type SYS2: [RETURN]

The screen displays:

PREFIX IS SYS2:

17. Press Q

The screen displays:

COMMAND: E{DIT, R{UN, F{ILE, C{OMP, L{IN

18. Press X

The screen displays:

EXECUTE WHAT FILE?

19. Type PRIVATE:VINIT [RETURN]

The screen displays:

VINIT: I{NIT D{OSVOL C{ONST S{EM4INIT P{IPES

20. Press C

The screen displays:

WHICH DRIVE SHOULD BE SET UP (1..2)? 2

21. Press 2 [RETURN]

The screen displays:

THIS PROGRAM WILL
---GIVE THE USER WHOSE ID IS #1 FULL ACCESS TO
THE SYSTEM
--SET ITS ID TO SMGR WITH NO PASSWORD
--GIVE ALL OTHER USERS NO PASCAL ACCESS
THE FMGR P{REFIX MUST BE SET TO THE FIRST
VOLUME ON THE CORVUS DRIVE (1..2)

CONTINUE (Y/N) ?

22. Press Y

The screen displays:

.....
.....
.....
.....
.....
DONE THE CONSTELLATION USER TABLE IS NOW
INITIALIZED CONFIRM ZERO USER TABLE: N

23. Press N

The screen displays:

VINIT: E{DIT R{UN F{ILE C{OMP L{IN

24. Press Q

The screen displays:

```
COMMAND: E[EDIT R[UN F[ILE C[OMP L[IN
```

Setting Boot to Constellation

If you plan to have a Pascal-BASICS system, skip to the next section. Otherwise, proceed with the next five steps to have a Pascal only system.

When a single computer system without Constellation software boots, the user has access to the entire drive. To require the entry of a log-on name to boot, you must run the SETBOOT program.

1. Press X

The screen displays:

```
EXECUTE WHAT FILE ?
```

2. Type PRIVATE:SETBOOT [RETURN]

The screen displays:

```
CORVUS BOOT SELECTION PROGRAM [1.2]:
```

```
P[PASCAL B[BASICS C[ONST ◀esc▶:
```

3. Press C

The screen displays:

```
SETTING BOOT FOR PASCAL 1.1...
```

```
OPENING BOOT.DATA...  
CORVUS BOOT NOW SET TO CONSTELLATION
```

4. Press H

The system prints a log-on message asking for your name.

The screen displays:

```
CORVUS
CONSTELLATION
  *
   *
  * *
   *
  *
```

PLEASE ENTER YOUR NAME: __

5. Type SMGR [RETURN]

The screen displays:

```
COMMAND: E[DIT R[UN F[ILE C[OMP L[IN
```

The Pascal only system has now been upgraded for use with Constellation software. Proceed to the SYSTEM MANAGER'S GUIDE FOR APPLE II COMPUTERS for details on Constellation software.

ADDING BASICS TO PASCAL

This chapter provides instructions for adding Apple BASICS (DOS 3.3) system to a Model 6, Model 11, or Model 20 Corvus Winchester disk drive which has been initialized with Apple Pascal, for use with Omninet and Apple II computers.

A drive which has been initialized with Apple Pascal can be divided into variable-sized areas called volumes which can be as large as 10 megabytes. The volumes which you create, however, will all use the Pascal operating system and file structure. The procedures in this chapter allow you to add fixed-sized volumes which use the BASICS operating system and file structure. Each BASICS volume is equivalent in capacity to one diskette.

A Pascal or BASICS volume on a Corvus disk is similar to a floppy, in that it can store multiple files with a file directory, and can be brought online or taken offline at will.

Creating BASICS Volumes

1. After you have initialized your Corvus disk drive with Apple Pascal, the Pascal command line displays:

```
COMMAND: EDIT R{UN F{ILE C{OMP L{IN
```

2. At the end of Chapter 3, you used the Pascal filer to list all files in the SYS: volume of the Corvus drive. Creating Apple BASICS (DOS 3.3) volumes on a drive which has been initialized for Pascal requires that the files BASICS3.DATA and BASICS3.OMNI appeared as a part of that list.

If those two files exist in the SYS: volume:

Press X

The screen displays:

```
EXECUTE WHAT FILE?
```

3. Type VINIT [RETURN]

The screen displays:

VINIT: I[NIT D[OSVOL C[ONST S[EM P[IPES

4. Press D

The screen displays:

CREATE DOS VOLUMES ON DRIVE 1? Y

5. Press [RETURN]

The screen displays:

ENTER # OF DOS VOLUMES (MAX = XX): 20

The maximum number of DOS volumes you may create on a drive initialized for Pascal, represented here as "XX," varies according to which Corvus drive model you have. A Model 6 Pascal/BASICS drive may have up to 37 DOS volumes. A Model 11 Pascal/BASICS drive may have up to 80 DOS volumes. Either half of a Model 20 Pascal/BASICS drive may have up to 59 DOS volumes, but the number of DOS 3.3 volumes on drive 2 of a Model 20 drive must equal the number of DOS 3.3 volumes on drive 1.

6. Select the number of DOS volumes you wish to create. For example, to create 15 volumes:

Type 15 [RETURN]

The screen displays:

MOUNTING DOS1 ON #9

OPENING BASICS3. DATA
WRITING DOS1:DOSVOLUMES

.....

ZEROING DOS1:DOSVOLUMES

.....

UNMOUNTING DOS1

VINIT: I[NIT D[OSVOL C[ONST S[EM P[IPES

7. If you have a Model 6 or Model 11 drive, skip to Step 11.

If you have a Model 20 drive, proceed with Steps 8-10 to create DOS volumes on the second half of the drive.

8. To create DOS 3.3 volumes on the second half of a Model 20 drive:

Press D

The screen displays:

CREATE DOS VOLUMES ON DRIVE 2? Y

9. **Press [RETURN]**

The screen displays:

CREATING XX DOS VOLUMES ON DRIVE 2

The number of DOS volumes created on logical drive 2 of a Model 20 drive, represented here as "XX," will equal the number of DOS volumes you previously created on logical drive 1.

10. The screen displays:

MOUNTING DOS2: ON #9:

OPENING BASICS3. DATA

WRITING DOS1:DOSVOLUMES

.....

ZEROING DOS1:DOSVOLUMES

.....

UNMOUNTING DOS1

VINIT: I(NIT D(OSVOL C(ONST S(EM P(IPES

11. To exit the VINIT program:

Press Q

The screen displays:

```
COMMAND: E(DIT R(UN F(ILE C(OMP L(IN
```

Continue to the next section, "Installing the Operating System Patch."

Installing the Operating System Patch

In order for a Corvus drive to function under Apple DOS 3.3, a patch must be installed in the operating system. The procedure in this section installs this Corvus patch.

1. To switch the Apple II from operating in Pascal to operating in BASICS:

Press X

The screen displays:

```
EXECUTE WHAT FILE ?
```

2. **Type BASICS [RETURN]**

The screen displays:

```
-----  
CORVUS 11AP  
(DOS 3.3 OPERATING SYS.)  
-----
```

]

3. Clear out high memory of the Apple:

Type FP [RETURN]

The screen displays:

]

4. Place the CORVUS AP UTILITIES BASICS — DOS 3.3 diskette in the diskette drive.
5. You will now store an image of Apple DOS 3.3 with the Corvus patch installed. This image will be used to boot up the Apple from the Corvus drive. To store this image in Apple memory:

Type LOAD APPLESOFT BOOT PREP, S4 [RETURN]

The screen displays:

]

6. To catalog the first DOS 3.3 volume on the Corvus drive:

Type CATALOG,S6,V1,D1 [RETURN]

The screen displays:

DISK VOLUME 001

]

The screen shows that the first DOS volume on the drive contains no information.

7. **Type** RUN [RETURN]

The screen displays:

CORVUS 11AP
DOS 3.3

]

Initializing Volume Directories

Although the VINIT program initialized the BASICS (DOS 3.3) area of the Corvus drive, the directory of each DOS volume also needs to be initialized.

1. To initialize the directories of the DOS volumes you created:

Type RUN VOLUME INIT,S4 [RETURN]

The screen displays:

VER 4.4
BULK VOLUME INITIALIZATION PROGRAM
19-JUL-81

INITIALIZES A GIVEN RANGE OF VOLUMES

WHICH DRIVE (1 OR 2)?

2. Press 1

The screen displays:

FIRST VOLUME (1 TO XX)?

3. Press 1 [RETURN]

The screen displays:

LAST VOLUME (1 TO XX)?

4. Type the number of DOS volumes you created previously with VINIT.

For example, if there are 20 volumes:

Type 20 [RETURN]

The screen displays:

INITIALIZE VOLUMES 1 THRU XX ON DRIVE 1
ARE YOU SURE?

5. Press Y

The screen displays:

VOLUME X INITIALIZED.

INITIALIZING VOLUME Y.

As each of the volumes is initialized, the displayed volumes (represented here as X and Y) change on the screen.

Finally, when all volumes have been initialized, the screen displays:

VOLUMES 1 THRU XX ARE INITIALIZED.

]

6. If you have a Model 6 or Model 11 disk system, skip Steps 8-12 and proceed to the next section, "Copying BASICS Files to the Hard Disk."

If you have a Model 20 drive, continue with Steps 8-12 to

initialize DOS volume directories on the second half of the drive.

7. To initialize DOS volume directories on the second half of a Model 20 drive:

Type RUN VOLUME INIT,S4 [RETURN]

The screen displays:

VER 4.4
BULK VOLUME INITIALIZATION PROGRAM
19-JUL-81

INITIALIZES A GIVEN RANGE OF VOLUMES

WHICH DRIVE (1 OR 2)?

8. Press 2

The screen displays:

FIRST VOLUME (1 TO XX)?

9. Press 1 [RETURN]

The screen displays:

LAST VOLUME (1 TO XX)?

10. Type the number of DOS volumes you created on drive 2 with the VINIT program. For example, if there are 20 DOS volumes:

Type 20 [RETURN]

The screen displays:

INITIALIZE VOLUMES 1 THRU 20 ON DRIVE 2
ARE YOU SURE?

11. Press Y

The screen displays:

VOLUME X INITIALIZED.

INITIALIZING VOLUME Y.

As each of the volumes is initialized, the displayed volumes (represented here as X and Y) change on the screen. Finally, when all volumes have been initialized, the screen displays:

VOLUMES 1 THRU XX ARE INITIALIZED.

]

Copying BASICS Files to the Hard Disk

When you have initialized all DOS 3.3 volumes on the Corvus drive, the CORVUS AP UTILITIES BASICS—DOS 3.3 diskette is still in the diskette drive. Copy the contents of this diskette (slot 4, drive 1, volume 0) to the DOS1 volume on the Corvus drive (slot 6, drive 1, volume 1).

1. Type CATALOG, S6,D1,V1 [RETURN]

The screen displays:

]

2. Type RUN COPY3,S4 [RETURN]

The screen displays:

VER 4.2
CORVUS SYSTEMS C O P Y 3
COPYRIGHT © 1979 BY PERSONAL SOFTWARE
13-MAR-81

ONLY DOS 3.3 VOLUMES CAN BE
SUCCESSFULLY COPIED

FROM SLOT (4):?

3. Press [RETURN]

The screen displays:

FROM DRIVE (1):?

4. Press [RETURN]

The screen displays:

FROM VOLUME (0):?

5. Press [RETURN]

The screen displays:

TO SLOT (6):?

6. Press [RETURN]

The screen displays:

TO DRIVE (1):?

7. Press [RETURN]

The screen displays:

TO VOLUME (1):?

8. Press [RETURN]

The screen displays:

FROM:

SLOT— 4
DRIVE— 1
VOLUME— 0

TO:

SLOT— 6
DRIVE— 1
VOLUME— 1

OK TO COPY?

9. Press Y

After about two minutes, the screen displays:

0 ERRORS DURING COPY
COPY AGAIN?

10. Press N

The screen displays:

]

Your Corvus drive is now configured for both Apple Pascal and Apple BASICS (DOS 3.3).

To gain familiarity with your Corvus disk system and related software, continue to the CORVUS DISK SYSTEM USER'S GUIDE FOR APPLE II COMPUTERS. The User's Guide can also be used to add more Corvus disk drives to your system.

To supervise a multi-user network of Apple II computers and Corvus disks, see the CORVUS SYSTEM MANAGER'S GUIDE FOR APPLE II COMPUTERS.

Upgrading Pascal-BASICS with Constellation Software

To upgrade a Pascal-BASICS system for use with Constellation software, you began by following the procedures in Chapter 4 INITIALIZING FOR PASCAL. While following this Chapter, users of Pascal-BASICS were instructed NOT to complete the subsection SETTING BOOT TO CONSTELLATION. If you are upgrading the BASICS area of a Pascal-BASICS system, the boot cannot be set to Constellation.

Upgrading the BASICS Area

1. Press X

The screen displays:

EXECUTE WHAT FILE?

2. Type SYS:BASICS [RETURN]

The screen displays:

CORVUS 11 AP
DOS 3.3

]

3. Type FP [RETURN]

The screen displays:

]

- 4. Place the Constellation AP Utilities—BASICS—DOS 3.3 diskette in the floppy drive. This will be copied to drive 1, volume 2 on the Corvus disk. Therefore, remove any valuable files from that volume before continuing with this procedure.**

5. Type RUN COPY3,S6,V1, [RETURN]

The screen displays:

VER 4.2
CORVUS SYSTEMS COPY3
COPYRIGHT © 1979 BY PERSONAL SOFTWARE
13-MAR-81

ONLY DOS 3.3 VOLUMES CAN BE
SUCCESSFULLY COPIED

FROM SLOT (4) :?

6. Press [RETURN]

The screen displays:

FROM DRIVE (1) :?

7. Press [RETURN]

The screen displays:

FROM VOLUME (0) :?

8. Press [RETURN]

The screen displays:

TO SLOT (6) :?

9. Press [RETURN]

The screen displays:

TO DRIVE (1) :?

10. Press [RETURN]

The screen displays:

TO VOLUME (1) :?

11. Type 2 [RETURN]

The screen displays:

FROM

SLOT— 4
DRIVE— 1
VOLUME— 0

TO

SLOT— 6
DRIVE— 1
VOLUME— 2

OK TO COPY ?

12. Press Y

The screen displays:

O ERRORS DURING COPY
COPY AGAIN?

13. Press N

The screen displays:

]

14. Type RUN CONSTCREATE,S6,V2 [RETURN]

The screen displays:

VER 4.2
CONSTELLATION VOLUME PREP
08-APR-81

THIS PROGRAM WILL MAKE A GROUP OF
BASICS VOLUMES PROTECTED AGAINST
ALL CONSTELLATION USERS EXCEPT
USER NUMBER ONE, WHO WILL BE GIVEN
WRITE ACCESS TO ALL VOLUMES.

CONTINUE (Y/N) ?

15. Press Y

The screen displays:

DRIVE (1 OR 2) :

16. Press 1

The screen displays:

STARTING VOLUME (1..XX) :

17. Press 1 [RETURN]

The screen displays:

ENDING VOLUME (1..XX) :

18. Enter the number of the last BASICS volume on your disk drive.

For example, **type** 20 [RETURN]

The screen displays:

```
CONST PREP VOLS 1 THRU XX ON DRIVE 1
ARE YOU SURE?
```

19. Press Y

The screen displays:

```
INITIALIZING VOLUMES...
END OF PROGRAM
]
```

Adding BASICS to a Model 20 Drive

If you have a Model 6 or 11 drive, skip to the next section. If you have a Model 20 drive, the CONSTCREATE program must be repeated to initialize the volumes on the second logical drive for use with Constellation software.

1. Type RUN CONSTCREATE,S6,V2 [RETURN]

The screen displays:

```
VER 4.2
CONSTELLATION VOLUME PREP
08-APR-81
```

```
THIS PROGRAM WILL MAKE A GROUP OF
BASICS VOLUMES PROTECTED AGAINST
ALL CONSTELLATION USERS EXCEPT
USER NUMBER ONE, WHO WILL BE GIVEN
WRITE ACCESS TO ALL VOLUMES
```

```
CONTINUE (Y/N) ?
```

2. Press Y

The screen displays:

```
DRIVE (1 OR 2) :
```

3. Press 2

The screen displays:

STARTING VOLUME (1..XX) :

4. Press 1 [RETURN]

The screen displays:

ENDING VOLUME (1..XX) :

5. Enter the number of the last BASICS volume on your disk drive.

For example, **type 20 [RETURN]**

The screen displays:

CONST PREP VOLS 1 THRU 20 ON DRIVE 2
ARE YOU SURE?

6. Press Y

The screen displays:

INITIALIZING VOLUMES...
END OF PROGRAM

Setting Boot to Constellation

When a single computer system without Constellation software boots, the user has access to the entire drive. To require the entry of a log-on name to boot, you must run the SETBOOT program.

1. Type RUN SETBOOT,V1,S6 [RETURN]

The screen displays:

VER 4.5
CORVUS BOOT SELECTION PROGRAM
09-SEP-81

P[ASCAL B[ASICS C[ONST Q:

2. Press C

The screen displays:

```
LOADING SETBOOT.OBJ.....
SETTING BOOT PASCAL VERSION 1.1
CORVUS BOOT NOW SET UP TO CONSTELLATION
```

Reboot

The Pascal-BASICS system is now upgraded with Constellation software. To test it, you may boot the system to the new Constellation based system.

1. Type PR#6 [RETURN]

The screen displays:

```
  C O R V U S
  C O N S T E L L A T I O N
      *
      *
     * *
     * *
      *

```

PLEASE ENTER YOUR NAME: ___

2. Type SMGR [RETURN]

The screen displays:

```
COMMAND: E[EDIT, R[UN, F[ILE, C[OMP, L[IN
```

You have now upgraded to a Constellation multi-user system for the Apple II computer UNDER BOTH PASCAL AND BASICS. Proceed to the APPLE SYSTEM MANAGER'S GUIDE FOR APPLE II COMPUTERS for details on Constellation software.