

CENTRONICS

CENTRONICS

CENTRONICS

MODEL 358-3,-4
**Operator, Installation &
Programming Instructions**

37403591-9100

MAY 1983

CENTRONICS

CENTRONICS

CENTRONICS

CENTRONICS

USERS MANUAL

THE INFORMATION CONTAINED HEREIN IS
PROPRIETARY AND IS NOT TO BE RELEASED
OR REPRODUCED WITHOUT WRITTEN PERMIS-
SION OF CENTRONICS DATA COMPUTER CORP.

SERVICING INFORMATION FOR YOUR PRINTER MAY BE
OBTAINED BY CALLING THE NUMBERS LISTED BELOW.
(ASK FOR FIELD ENGINEERING)

CENTRONICS® data computer corporation

Hudson, New Hampshire 03051

Tel. (603) 883-0111, TWX. (710) 228-6565, TLX. 94-3404

Field Engineering Headquarters (603) 883-0111

Regional Sales Offices

Northern Region (Mass.): Tel. (617) 935-6150, TWX. 710-348-0343
Mid-Atlantic Region (NJ): Tel. (609) 234-8266, TWX. 710-897-1975
Southern Region (Texas): Tel. (817) 461-5711, TWX. 910-890-4916
Western Region (Calif.): Tel. (714) 979-6650, TWX. 910-595-1925
Northwest Region (Calif.): Tel. (408) 744-1244, TWX. 910-339-9324

District Field Engineering Offices

New England District : Tel. (617) 935-8130
New York District : Tel. (516) 496-3506
Mid-Atlantic District: Tel. (609) 234-8194
Midwest District: Tel. (312) 956-6141
Southern District: Tel. (817) 461-7121
Southwest District: Tel. (714) 957-1510
Northwest District: Tel. (408) 745-7040

International Offices

Centronics Data Computer (Canada) Ltd.
Mississauga, Ontario
Tel. (416) 625-0770, TWX. 610-492-4382

Centronics Data Computer (UK) Ltd.
Burgess Hill, Sussex, England
Tel. 04446-45011, TLX. 877801

Centronics Data Computer (France)
71-73 Rue Desnouettes, 75015 Paris, France
Tel. 828-4051, TLX. 202686

Centronics Data Computer (Germany), Gmbh
6000 Frankfurt am Main 71
Tel. 666-1021, TLX. 841-413224

Centronics of Puerto Rico
Dorado, Puerto Rico
Tel. (809) 796-1881, TLX. 385-9349

Centronics (Italia) S.P.A.
Via Santa Valeria 5, 20123 Milan, Italy
Tel. 809-516

© Copyright 1982 Centronics Data Computer Corp.
All rights reserved
Patents pending in U.S.A. and other countries
Printed in U.S.A.

Specifications subject to change without notice

MODEL 358-3,-4

Operator, Installation & Programming Instructions

37403591-9100

MAY 1983

USERS MANUAL

IMPORTANT NOTE

This manual supports preproduction, customer evaluation units. Certain information contained herein may be inaccurate.

WARNING

This equipment generates, uses, and can radiate radio frequency energy and if not installed and used in accordance with the operators manual, may cause interference to radio communications. It has been tested and found to comply with the limits for a Class A computing device pursuant to Subpart J of Part 15 of FCC Rules, which are designed to provide reasonable protection against such interference when operated in a commercial environment. Operation of this equipment in a residential area is likely to cause interference in which case the user at his own expense will be required to take whatever measures may be required to correct the interference.

JANUARY 1, 1981

APPROVED, CLASS A

Note: Must be used with shielded data cables only.

TABLE OF CONTENTS

OPERATORS INFORMATION	I
INTRODUCTION	I-1
SECTION 1—CONTROLS AND INDICATORS	
1.1 GENERAL	1-1
1.2 MECHANISM CONTROLS AND SWITCHES	1-1
1.3 SET-UP CONTROL SWITCHES AND INDICATORS	1-2
1.4 FEATURE/CONFIGURATION CONTROL SWITCHES AND DISPLAY	1-4
1.5 ERROR CODE DISPLAY	1-4
SECTION 2—FEATURES AND CONFIGURATIONS	
2.1 INTRODUCTION	2-1
2.2 FEATURES AND CONFIGURATIONS	2-1
2.3 SETTING FEATURES AND CONFIGURATIONS	2-2
2.4 PRINTER MEMORIES	2-2
2.5 SELECTING FEATURES	2-4
2.6 SELECTING CONFIGURATIONS	2-13
2.7 FACTORY SETTINGS	2-23
SECTION 3—PAPER LOADING/RIBBON REPLACEMENT	
3.1 GENERAL	3-1
3.2 INITIAL LOADING, FANFOLD FORMS	3-1
3.3 SETTING TOF; FANFOLD FORMS	3-2
3.4 RELOADING FANFOLD FORMS	3-3
3.5 INITIAL LOADING, CUT SHEET FORMS	3-4
3.6 RELOADING CUT SHEET FORMS	3-5
3.7 PRINTSTAND PAPER LOADING	3-6
3.8 FORMS DESIGN	3-8
3.9 FORM LOADING, CUT SHEET FEEDER	3-9
3.10 RIBBON CASSETTE REPLACEMENT	3-10
3.11 PRINT HEAD IMPRESSION ADJUSTMENT	3-12
SECTION 4—PRINTER OPERATION	
4.1 OPERATING NOTES	4-1
4.2 OPERATING THE PRINTER	4-1
4.3 OVERRIDE SELF-TEST PRINTOUT	4-2
4.4 ERROR CODES	4-4
SECTION 5—PRINTER MAINTENANCE	
5.1 PREVENTIVE MAINTENANCE	5-1
5.2 TROUBLESHOOTING GUIDE	5-2
SECTION 6—REMOVAL/REPLACEMENT	
6.1 GENERAL	6-1
6.2 REMOVAL COVER ASSEMBLIES	6-1
6.3 REMOVAL/REPLACEMENT PRINT HEAD ASSEMBLY	6-2
6.4 REMOVAL/REPLACEMENT INPUT FUSE	6-3

INSTALLATION, INTERFACE & SPECIFICATIONS II

SECTION 7—INSTALLATION

7.1 GENERAL	7-1
7.2 PRINTER INSPECTION	7-1
7.3 SITE CONSIDERATIONS	7-1
7.4 PRINTER SET-UP	7-2

SECTION 8—INTERFACE INFORMATION

8.1 GENERAL	8-1
8.2 PARALLEL INTERFACE CONNECTION	8-1
8.3 SERIAL INTERFACE CONNECTION	8-2

SECTION 9—SPECIFICATIONS

9.1 MODEL 358-3,-4 SPECIFICATIONS	9-1
---	-----

PROGRAMMING INFORMATION III

SECTION 10—PROGRAMMING INFORMATION

10.1 GENERAL	10-1
10.2 CONTROL CODES	10-1
10.3 ESCAPE SEQUENCES	10-5
10.4 SELECTING CHARACTER SETS	10-9
10.5 PROGRAMMING CONSIDERATIONS	10-10

SECTION 11—PRINT GENERATION

11.1 GENERAL	11-1
11.2 PRIMARY CHARACTER SET	11-1
11.3 CUSTOMER PROGRAMMABLE SET	11-1
11.4 DOWNSTREAM LOADED CHARACTER SET	11-3
11.5 MULTIPASS CHARACTER SET	11-5
11.6 GRAPHICS	11-6
11.7 COLOR PRINTING	11-9

OPTIONS AND ACCESSORIES IV

SECTION 12—OPTIONS AND ACCESSORIES

12.1 GENERAL	12-1
12.2 OPTIONS	12-1
12.3 ACCESSORIES	12-1

APPENDIX A—SETTING HORIZONTAL TABS

A.1 INTRODUCTION	A-1
A.2 SETTING HORIZONTAL TABS; SINGLE DENSITY PRINT	A-1
A.3 SETTING HORIZONTAL TABS; MIXED DENSITY PRINT	A-1

APPENDIX B—INTERNATIONAL CHARACTERS

B.1 GENERAL	B-1
-------------------	-----

INTRODUCTION

This manual details the installation, operation, and maintenance of the Model 358-3,-4 Printer. Model 358-3,-4 is a commercial-grade dot matrix printer capable of handling a wide variety of printing tasks. Some of the more significant features and functions of the printer include:

- 400 CPS, "Draft Mode" Printing
- 100 CPS "Correspondent Quality" Printing
- 7 × 8 Dot Matrix
- 7 × 9 Dot Matrix
- 4 Character Sets
- Pin Addressable Graphics
- Demand Document Capability
- Serial or Parallel Inputs
- Fanfold or Cut Sheet Paper Handling
- Six-Part Form Handling
- 13.2" Print Line (Fanfold)
- 12" Print Line (Cut Sheet)
- Forward or Reverse Paper Motion
- 8 IPS Slew Rate
- Automatic Line Feed Feature
- Selectable Print Parameters
- Selectable Communication Format
- On Line or Local Operation
- Memory Feature
- 3 Digit Liquid Crystal Display
- Automatic Fault Detector
- Self-Test Capability
- Audio Alarm
- 7 Control Panel Indicators
- Sheet Feeder Option
- Color Capability

The printer is lightweight, easy to install and operate, and compatible with both EIA and ANSI standards.

In addition to the standard features built into the Model 358-3,-4, there are many options and accessories that may be used with the printer to extend its capabilities. Foremost among these is the optional three-bin sheet feeder.

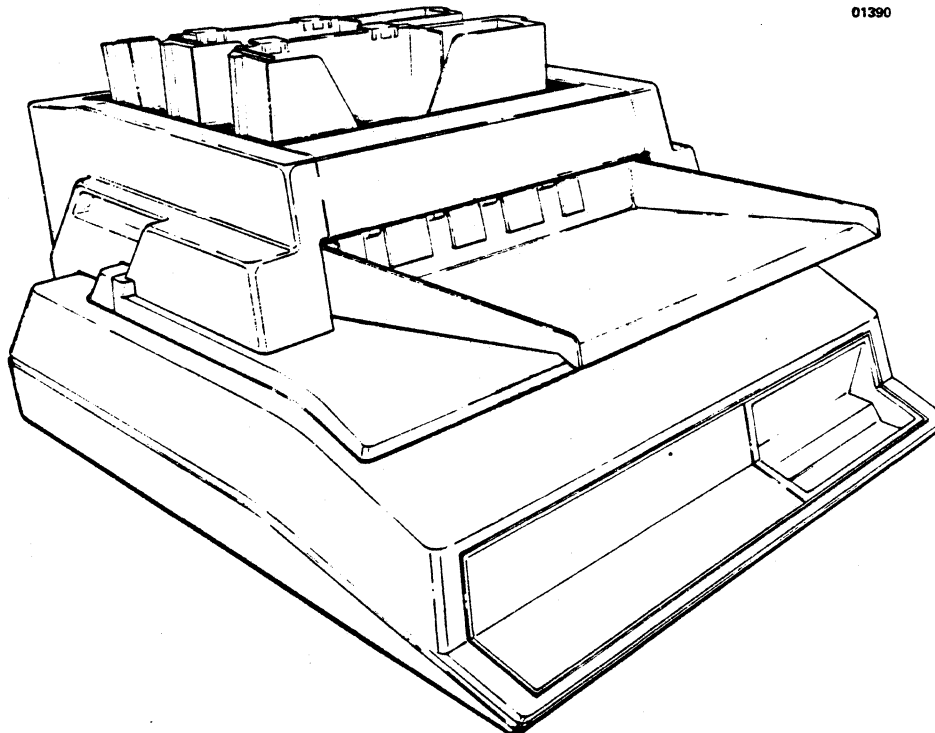

01390

Figure I-1 Model 358-3,-4 Printer with Optional Sheet Feeder

The optional sheet feeder permits the printer to handle three different forms at one time. Some of the more important feeder features include:

- All Mechanical Design—No electrical connections are required.
- Cartridge Loading—Feeder accepts interchangeable paper cartridges.
- Three Cartridge Capability—Feeder accepts up to three cartridges at one time.
- Wide Handling Capability—Cartridges may be loaded with cut sheet, multipart, and glued forms.
- Optional Cartridges—Envelope and adjustable-width cartridges are available.
- Automatic Operation—Feeder operation can be controlled via host generated escape sequences.
- Manual Operation—Feeder operation can be controlled locally, from printer control panel.
- Bin Feature Selection—6 print parameters can be set for each cartridge bin.
- Local or Downstream Selection of Bin Features.
- Paper Tray—standard feeder tray mounts on the front of the feeder and accepts forms as they leave the printer.

Many printer functions are dedicated to selecting and powering the sheet feeder. This manual documents all printer functions, including those exclusively used to control the feeder, but **does not** document the feeder itself.

NOTE

The sheet feeder is shipped with a technical manual (Sheet Feeder Manual, P/N 37403506) which documents feeder installation, paper loading, maintenance, and troubleshooting. The feeder manual must be used in conjunction with this manual for complete documentation of Model 358-3,-4 with Sheet Feeder.

SECTION 1

CONTROLS AND INDICATORS

1.1 GENERAL

A number of controls, switches and indicators are used to control printer operation. This section describes the controls and indicators and is organized as follows:

- 1.2 Mechanism Controls and Switches
- 1.3 Set-Up Control Switches and Indicators
- 1.4 Feature/Configuration Control Switches and Display
- 1.5 Error Code Display

1.2 MECHANISM CONTROLS AND SWITCHES

Figure 1-1 illustrates the printer mechanism controls and switches with which an operator should be familiar. A brief description of each control and switch is provided below.

POWER SWITCH—When placed in the ON position, applies power to the printer.

COVER INTERLOCK SWITCH—A safety feature which automatically stops the printer when the top cover is opened.

FORMS LEVER—The forms lever can be set to any one of three positions: **LOAD**, **SHEET**, or **FORMS**.

NOTE

Ensure the carriage is at the extreme left margin before moving the forms lever.

Load—In this position either fanfold forms or cut sheet forms can be loaded into the printer.

Sheet—In this position the printer is set-up to handle single cut sheet (non-tractor type) forms.

Forms—In this position, the printer is set-up to handle continuous fanfold forms.

PAPER EMPTY SWITCH—Detects a paper empty condition, automatically stopping the printer and sounding the audio alarm.

PRINT HEAD ADJUSTMENT LEVER—Adjusts the print head in or out for optimum print quality.

AUDIO ALARM—Sounds a one second tone on a paper empty condition, fault condition, receipt of a BEL code, or when the **SET TOF** switch, **ENTER** key, or **CLEAR** key is pressed.

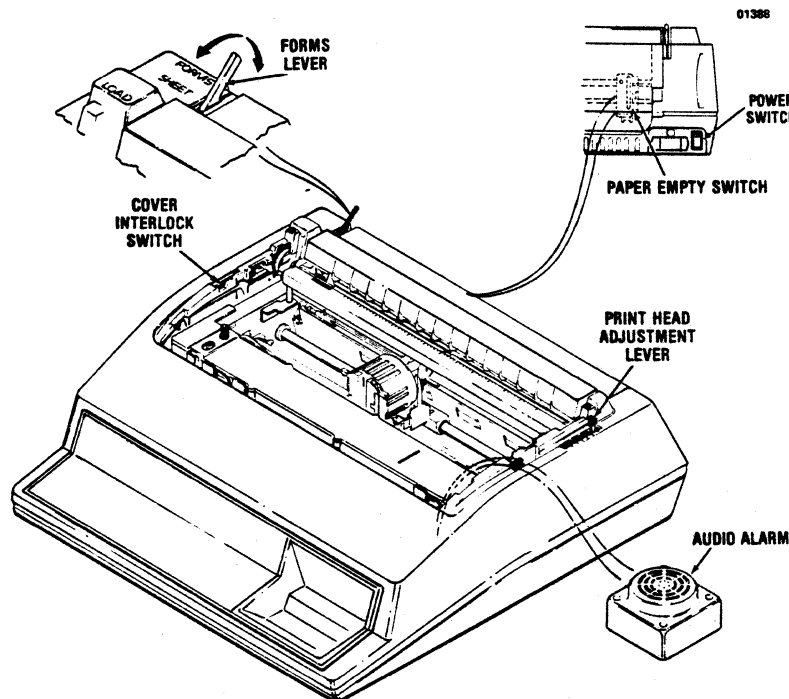

Figure 1-1 Printer Mechanism Controls and Switches

1.3 SET-UP CONTROL SWITCHES AND INDICATORS

The switches and indicators located to the left of the control panel (Figure 1-2) are used to set-up the printer while it is in off-line mode (deselected). A brief description of each switch and indicator follows:

- ON LINE
 - Pressing **ON LINE** in off-line mode:
 - Alternately selects/deselects the printer as indicated by the **ON LINE** and **SELECT** indicators (parallel interface)

OR

 - Alternately places the printer on-line/local as indicated by the **ON LINE** indicator (serial interface).
- Pressing **ON LINE** and **OVRD TEST** overrides the automatic deselection of the printer during a paper-empty condition.
- Pressing **ON LINE** when the printer is in feature or configuration mode resets the printer to off-line mode.

SET TOF Sets the current print line as the top of form.

MULTI-PASS Starts or stops multipass printing as indicated by the **MULTIPASS** indicator.

NOTE

The **MULTIPASS** switch is inhibited if the printer is in the graphics mode.

CUT SHEET MODE Places the printer either in or out of single cut sheet mode as indicated by the **CUT SHEET** indicator.

PAPER FWD Advances fanfold paper forward in steps of 1/120 of an inch and cut sheet forms in steps of 1/108 of an inch. If the switch is pressed for longer than 1/2 second, paper moves forward until the switch is released.

PAPER REV Performs the same function as the **PAPER FWD** switch except it moves paper in the reverse direction.

NOTE

Fanfold forms should not be reversed more than one half inch as paper handling problems may occur.

CUT SHEET INSERT When the printer is in single cut sheet mode, loads the sheet into the printer.

NOTE

If form length is two (2) inches or less the paper will be ejected.

10461-A

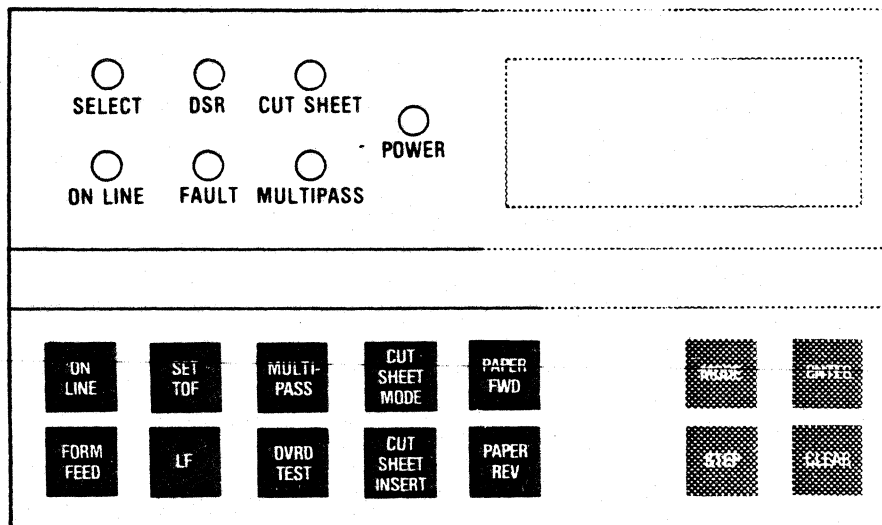

Figure 1-2 Set-up Switches and Indicators

OVRD TEST

The **OVRD TEST** switch controls four printer functions:

- Pressing **OVRD TEST** during power up loads the factory-set features and configurations (par. 2.5) into working memory.
- Pressing **OVRD TEST** while the printer is in feature mode causes the printer to go into configuration mode (refer to par. 2.4).
- Pressing **OVRD TEST** when the printer is out of the feature or configuration modes activates the printer self-test feature (refer to paragraph 4.3).
- Pressing both **OVRD TEST** and **ON LINE** overrides the automatic deselection of the printer during a paper empty condition. This allows printing to continue to the end of the form.

NOTE

If the serial interface is used the **OVRD TEST** switch selects and deselects the printer. The printer remains on-line when deselected.

LF

Can be used when the printer is (1) in off-line mode (i.e. deselected), or (2) in feature set-up mode with the feeder feature active.

LF advances the paper forward one line. If the switch is pressed for longer than 1/2 second, line feeds are repeated until the switch is released.

NOTE

If feeder bin 1, 2, or 3 is selected, repeated line feeds will eject the current page **WITHOUT** loading the next page from the active bin.

FORM FEED

Can be used when the printer is (1) in off-line mode (i.e. deselected), or (2) in feature set-up mode with the feeder feature active.

- If fanfold mode is selected, **FORM FEED** (1) advances a loaded fanfold form to the next top of form, or (2) ejects any cut sheet form then in the printer.
- If bin 1, 2, or 3 is selected, **FORM FEED**:
(1) ejects any form then in the printer, and then
(2) loads one form from the selected bin into the printer.

SET-UP INDICATORS**NOTE**

An indicator goes **ON** when the corresponding function is selected.

SELECT—The **SELECT** indicator performs one of two functions as described below:

PARALLEL INTERFACE— **SELECT** indicator follows the **ON LINE** indicator.

10461-B

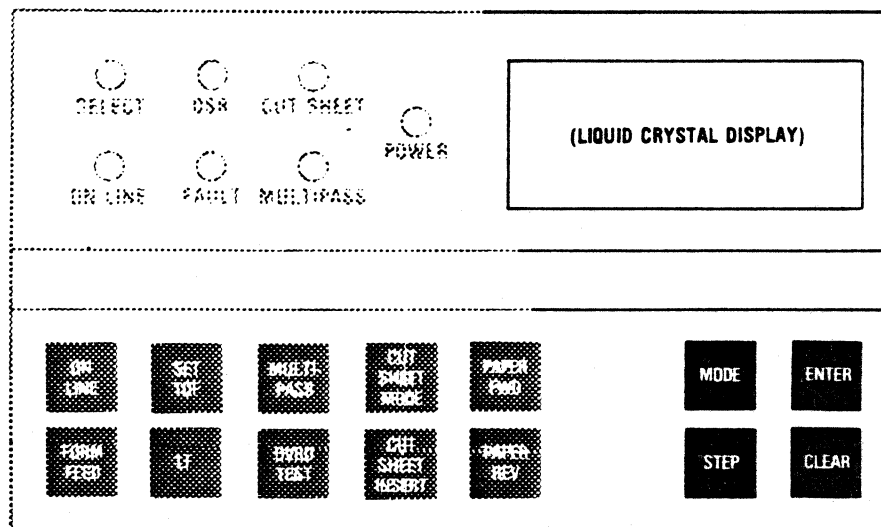

Figure 1-3 Feature/Configuration Control Switches and Display

SERIAL INTERFACE—SELECT indicator is controlled by the **OVRD TEST** switch. When lit, printer is selected and printing can occur. When extinguished, printer is deselected and no printing can occur.

DSR—Indicates the state of the modem Data Set Ready (DSR) line. Indicator is lit if DSR signal line is at +V or not connected to the data set.

CUT SHEET—Indicates the printer is in the cut sheet mode, or in one of the three feeder modes.

POWER—Indicates power is applied to printer circuits.

MULTIPASS—Indicates the printer is in multipass mode.

FAULT—Steady **ON** indicates:

- Fanfold paper is out.
- Attempt to load paper from an empty (or missing) sheet feeder cartridge.
- Sheet feeder misfeed.

ON LINE—Indicates the printer is on-line.

1.4 FEATURE/CONFIGURATION CONTROL SWITCHES AND DISPLAY

The four (4) switch keypad and a liquid crystal display on the right side of the control panel are used to select the various printer features and configurations.

A detailed description of the operation and function of the keypad and display is provided in Section 2, Selecting Printer Features and Configurations.

1.5 ERROR CODE DISPLAY

The printer performs a number of self-diagnostic operations. If an error is detected during a self-diagnostic operation, normal printer operation stops and an error code displays on the LCD.

Paragraph 4.4 defines the error codes and provides suggestions for clearing errors.

SECTION 2

FEATURES AND CONFIGURATIONS

2.1 INTRODUCTION

Over two dozen set-up parameters can be changed to (1) meet the printing requirements at hand, or (2) establish a proper communication format between printer and host device. The set-up parameters associated with printing are called **FEATURES**, while those related to communication formatting are called **CONFIGURATIONS**.

This section defines the individual features and configurations, and details procedures for verifying and setting the parameters from the printer control panel.

NOTE

The printer features may also be set from the host device. Refer to Section 10 for feature escape sequences.

2.2 FEATURES AND CONFIGURATIONS

There are eleven selectable features; a brief description of each follows:

FEEDER FEATURE—selects printer operating mode. Four settings can be selected:

- OFF... Selects the printer for fanfold/single cut sheet mode. "OFF" effectively deselects the feeder and configures the printer logic to move/print fanfold/single cut sheet forms.
- SF1... Selects the printer for sheet feeder mode, with bin 1 (front bin) active.
- SF2... Selects the printer for sheet feeder mode, with bin 2 (middle bin) active.
- SF3... Selects the printer for sheet feeder mode, with bin 3 (rear bin) active.

The next six (6) features govern print format. These features are set for bins 1, 2, and 3 of the feeder, and for fanfold/single cutsheet printing. Thus, the printer retains four separate sets of these features, but activates only one set at a time, depending on how the feeder feature is set. Similarly, only one set of these features can be changed at a given time, again depending on how the feeder feature is set.

HORIZONTAL TAB FEATURE—Sets horizontal (column) tab settings; 218 selectable settings.

VERTICAL TAB FEATURE—Sets vertical (line) tab settings; 192 selectable settings.

FORMS LENGTH FEATURE—Sets form length to one (1) of 192 selectable lengths.

VERTICAL MARGIN FEATURE—Sets top and bottom margins; 192 selectable settings.

CPI FEATURE—Sets character density to one (1) of ten (10) selectable densities.

LPI FEATURE—Sets line density to one (1) of five (5) selectable densities.

The next three features govern special functions. These three features **CANNOT** be set for the individual feeder bins and fanfold printing.

COUNTRY SET FEATURE—Selects one (1) of eight (8) international character sets for printing in all four modes.

AUTO LINE FEED FEATURE—Enables/disables automatic line feed operation in all four modes.

AUDIO ALARM FEATURE—Enables/disables the printer audio alarm in all four modes.

The last feature insures preservation of set-up parameters.

MEMORY FEATURE—Setting features and configurations involves reconfiguring the printer working memory, which is erased at power down. The memory feature can be set to copy the content of working memory into a permanent memory to retain new parameters after power down.

The sixteen configurations **must** be set from the control panel. Unless you intend to use the printer with different hosts, you'll probably set configurations only once—when you first install the printer.

Paragraph 2.6 describes each configuration and details control panel selection procedures.

2.3 SETTING FEATURES/CONFIGURATIONS

Features and configurations are set by:

- Placing the printer in either feature or configuration mode

AND

- Using the **MODE**, **STEP**, **ENTER**, and **CLEAR** switches (see Figure 2-1) to set the required parameters.

Once the printer is in either selection mode, the LCD displays: (1) legends or function codes which identify the feature or configuration being set, and (2) parameter settings.

Legends display on the right side of the LCD; function codes and/or settings display on the left side of the LCD.

Four control panel keys below the LCD are used to place the printer in either selection mode and to select parameter settings (refer to Figure 2-1).

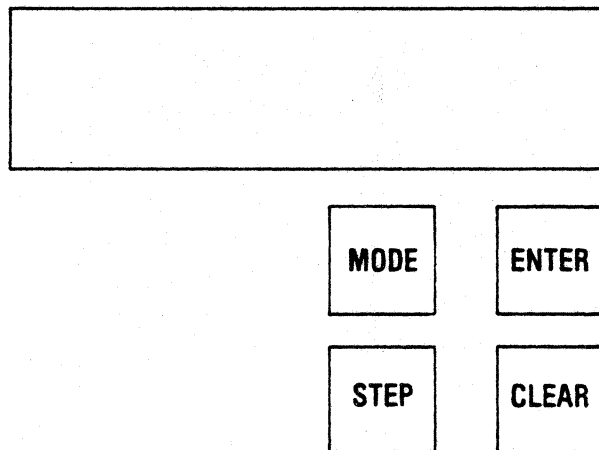

Figure 2-1 LCD and Control Switches

These keys perform the following functions:

MODE **MODE** controls entry into/exit from both the feature and configuration modes. **MODE** also steps the LCD through the feature legends/configuration codes when the printer is in a selection mode (refer to Table 2-1).

STEP Pressing **STEP** cycles the LCD through parameter settings.

ENTER Pressing **ENTER** while the feeder feature is active places the printer in fanfold mode, or in bin 1, bin 2, or bin 3 feeder mode.

Pressing **ENTER** while the memory feature is active causes the content of the working memory to be copied into the permanent memory. All feature and configuration settings are copied into permanent memory at such times.

Pressing **ENTER** when any other feature is active causes the displayed parameter setting to be entered into working memory.

Pressing **ENTER** when any configuration is active causes the displayed setting to be set in working memory.

CLEAR Pressing **CLEAR** when the memory feature is active causes all parameter settings in the permanent memory to be copied into working memory. Pressing **CLEAR** at other times places certain default parameters into working memory.

2.4 PRINTER MEMORIES

Three different memories are used to store set-up parameters. The function of each memory is described below:

1. Working Memory—Essentially a control memory. A complete set of set-up parameters resides in working memory while the printer is under power. As different operating modes are selected/deselected via feature mode, various segments of this memory become active or inactive. Although this memory controls printer operation, **it only functions while the printer is operating, and is erased at power down.**
2. Permanent Memory—A storage memory which holds a complete set of parameters **at all times.**

During power-up, the parameters in permanent memory are automatically copied into working memory, setting up the initial configuration. The printer can then be operated as configured or be placed in feature mode for a new operating mode/new parameter setting(s).

Setting new parameters changes the content of working memory but does not alter the permanent memory. Permanent memory can only be changed by using the memory feature.

Table 2-1 Feature Legends and Configuration Codes
(Displayed in the order shown)

FEATURE MODE LEGENDS		CONFIGURATION MODE CODES*	
Legend (Right side of LCD)	Feature	Function Code (Left side of LCD)	Configuration
FEEDER	FEEDER	(None)	BAUD RATE
HOR TAB or HOR TAB/FEEDER*	HORIZONTAL TABS	1	SERIAL/PARALLEL
VER TAB or VER TAB/FEEDER*	VERTICAL TABS	2	DATA BITS
FORMS L or FORMS L/FEEDER*	FORMS LENGTH	3	PARITY
VER MAR or VER MAR/FEEDER*	VERTICAL MARGINS	4	BUFFER STATUS
CPI or CPI/FEEDER*	CHARACTERS PER INCH	5	PRINTER STATUS
LPI or LPI FEEDER*	LINES PER INCH	6	REVERSE CHANNEL
COUNTRY	COUNTRY	7	} Used by Centronics for factory testing
AUTO LF	AUTOMATIC LINE FEED	8	
ALARM	AUDIO ALARM	9	INVERTED DATA STROBE
MEMORY	MEMORY	10	INVERTED DATA BIT 8
		11	BIT 8 CONTROL
		12	703/ANSI
		13	PRIME ON SELECT
		14	PRIME ON DELETE
		15	PRINT ON PAPER MOTION
		16	PAGE MODE ENABLE
*Indicates feature is being set for the bin selected in feeder feature mode.		*The right side of the LCD displays "CONFIG" whenever the printer is in configuration mode.	

The memory feature allows copying of the working memory into the permanent memory. By using memory after setting new parameters, you can copy the newly configured working memory into permanent memory. Doing so (1) insures preservation of your new settings after power down, and (2) guarantees the new parameters will be operational (i.e. be copied into working memory) at the next power up.

3. **Factory Settings Memory**—For your convenience, Centronics has included an unalterable, permanent memory which contains the set of set-up parameters listed in paragraph 2.8. You can copy from this memory into working memory any time you wish by:

1. Powering down the printer.
2. Powering up again while keeping the **OVRD TEST** switch depressed.

This causes the factory memory (instead of the permanent memory) to be copied into working memory.

2.5 SELECTING FEATURES

This section details local (control panel) selection of features.

The printer must be placed in feature mode before features can be verified, entered, or cleared.

SELECTING FEATURE MODE—To place the printer in feature mode, press **MODE** while the printer is in off-line mode.

NOTE

The printer is in off-line mode when it is under power, deselected, and not displaying any information on the LCD.

The LCD will display one of the following after **MODE** is pressed:

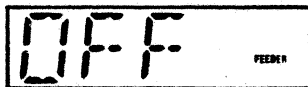

Indicates feeder is deselected and printer is in fanfold or single cut sheet mode.

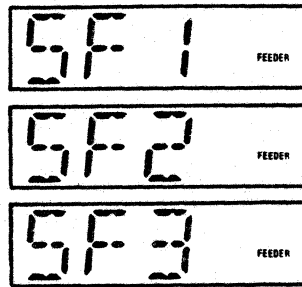

Indicates the printer is in feeder mode with bin 1, bin 2, or bin 3 active.

Anyone of these displays signals printer entrance into feature mode.

MODE, **STEP**, **ENTER**, and **CLEAR** may then be used to change mode, or to set features for the selected mode.

DESELECTING FEATURE MODE—There are three ways to deselect feature mode:

- Repeatedly press **MODE** until the LCD clears, indicating the printer has reentered off-line mode.
- Press **ON LINE** once, which also causes the printer to reenter off-line mode.
- Press **OVRD TEST**, which causes the printer to enter configuration mode.

FEATURE MODE NOTES

- Existing feature settings can be verified or cleared in feature mode.
- Feature legends are displayed on the right side of the LCD to show which feature is active.
- The "FEEDER" legend appears along with "HORTAB", "VERTAB", "FORMS L", "CPI", "LPI", or "VER MAR" when those features are active with the printer selected for SF1, SF2, or SF3 feeder mode.

NOTE

The "FEEDER" legend remains on to indicate one of the bins is being set up, but you must remember which bin (1, 2, or 3) is being set. When in doubt, go back to feeder feature to verify bin number.

The pages which follow describe each of the features in detail, and explain how to use **MODE**, **STEP**, **ENTER**, and **CLEAR** to verify, enter, or clear feature settings.

FEATURE—FEEDER

The feeder feature is the first selectable feature.

Four settings are associated with this feature:

- OFF—Deselects the feeder; configures the printer for fanfold/single cut sheet mode.
- SF1 Selects the feeder; configures the printer for feeder mode with bin 1, 2,
- SF2 or 3 selected.
- SF3

NOTE

Set this feature "OFF" if your printer is not equipped with the feeder.

TO SELECT THE FEEDER FEATURE

- Press **MODE** while printer is in off-line mode. This causes the printer to enter feature mode, and the LCD to display the "FEEDER" legend and one of the four possible settings. You may now verify/set operating mode.

TO VERIFY FEEDER SELECTION

- The setting displayed indicates which mode (OFF; SF1, 2, or 3) is active.

TO CHANGE FEEDER SELECTION

1. Press **STEP** until the required setting displays on the LCD.

NOTE

Remove fanfold forms before changing from "OFF" to "SF1", "SF2", or "SF3". **STEP** will not function if fanfold forms are loaded.

2. Press **ENTER** to activate the displayed mode.

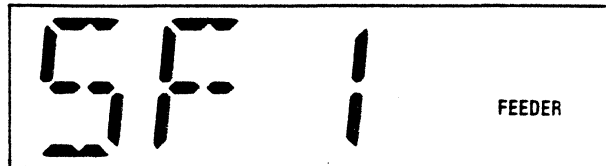

FEEDER MODE
SELECTION

MODE

ENTER

STEP

CLEAR

(Display indicates printer is in feeder mode with bin 1 feeder mode active).

NOTE

The **FF** and **LINEFEED** switches can be used when this feature is active. Refer to paragraph 3.9 for details.

FEATURE—HORIZONTAL TAB

The horizontal tab feature is used to set/verify the horizontal (line) tabs.

Horizontal tabs are associated with print columns, NOT with fixed physical locations. As a result, the physical location of a given tab changes each time character density (dpi) is changed. Two sample printouts are shown below to illustrate this important point.

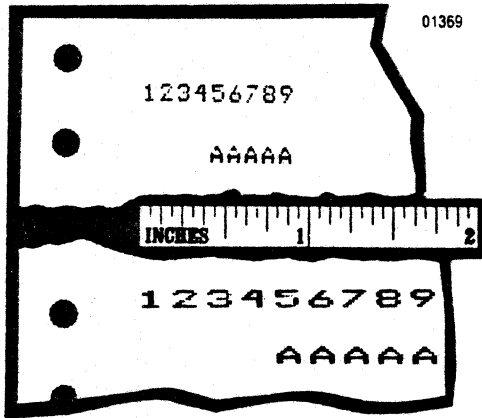

Both samples show some data—a string of upper case A's—printed with the first horizontal tab set for column 4 (the printed numbers identify print columns). Since the tab is set for column 4, the first A in each sample is printed in column 5. Note, however, that column 5 in the top sample (printed at 10 cpi) is closer to the left end of the ruler than column 5 in the bottom sample (printed at 5 cpi). Changing character density from 10 to 5 cpi has moved the tab location to the right.

Appendix A provides a reference figure (Figure A-1) that can be used to quickly determine the correct tab setting for any density, at any point on the form.

TO SELECT THIS FEATURE

- Place the printer in feature mode and press **MODE** until the LCD displays the "HOR TAB" legend and a "000" tab setting.

If the printer is in SF1, 2, or 3 feeder mode, the feeder legend will also be displayed; if the printer is in fanfold/single cut sheet mode, "FEEDER" will not be displayed. You may now verify, clear, or enter tab settings.



HORIZONTAL TAB SELECTION

000 to 218

MODE

ENTER

STEP

CLEAR

TO VERIFY TAB SETTINGS

- Press and hold **STEP**. The displayed setting will rapidly advance to the first active tab.
- To verify the next tab stop, press AND HOLD the **STEP** key, which causes the displayed setting to advance to the second tab setting.
- Repeat the press and hold procedure to verify remaining tab settings.
- To set new tabs, clear existing tabs and set new tabs as described below.

TO CLEAR HORIZONTAL TABS

- Press the **STEP** key until the LCD displays the horizontal tab position to be cleared.
- Press the **CLEAR** key to clear the tab.
- To clear all currently set horizontal tabs, press the **CLEAR** key when a "000" setting is displayed.

TO ENTER HORIZONTAL TABS

- Press the **STEP** key until the LCD displays the required horizontal tab position.
- Once the required tab position is displayed, press the **ENTER** key to set the horizontal tab.
- Repeat steps 1 and 2 above to set additional tabs.

FEATURE—VERTICAL TAB

The vertical tab feature is used to set/verify vertical stops.

Vertical tabs are associated with line numbers, NOT with fixed physical locations on the form. The physical location of a given tab changes when the lpi selection is changed. The two sample printouts shown below illustrate this important point. (Samples shown at approximately 60% of actual size).

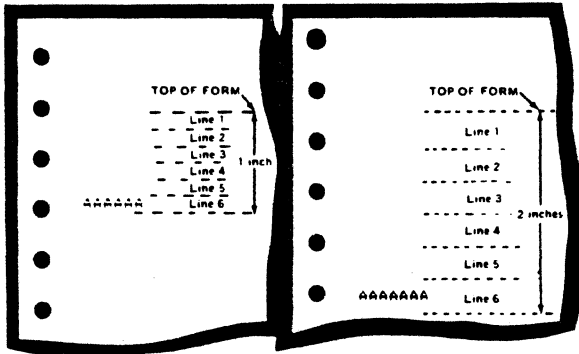

Each sample shows a line of data—a string of A's—that was vertically tabbed at line six (6). The sample to the left was printed with 6 lpi selected; the sample to the right was printed with 3 lpi selected. As can be seen, changing cpi has shifted the physical location of the tab.

TO SELECT THIS FEATURE

- Place the printer in feature mode and press **MODE** until the LCD displays the "VER TAB" legend and a "000" tab setting.

The "FEEDER" legend will remain displayed if the printer is in SF1, 2, or 3 feeder mode. You may now verify, clear, or enter vertical tabs.

TO VERIFY VERTICAL TABS

- Press and HOLD the **STEP** key. The displayed setting will advance to the first vertical tab setting.



VERTICAL TAB SELECTION

000 to 192

MODE

ENTER

STEP

CLEAR

- Repeat the press/hold procedure to verify the second vertical tab.
- Continue verifying the remaining tabs until the display returns to "000."
- To set new tabs, clear existing tabs and set new tabs as described below.

TO CLEAR VERTICAL TABS

- Press the **STEP** key until the LCD displays the vertical tab position to be cleared.
- Press the **CLEAR** key. This clears the displayed tab position.
- To clear all currently set vertical tabs press the **CLEAR** key with "000" displayed.

TO ENTER VERTICAL TABS

- Press the **STEP** key until the LCD displays the required vertical tab position.
- Once the required tab position is displayed, press the **ENTER** key to set the vertical tab.
- For each additional tab press the **STEP** key to the required position and then press the **ENTER** key.

FEATURE—FORMS LENGTH

The printer can be set to 192 different forms length settings.

Forms length (which is measured in lines, **NOT** inches) should be set to match: (1) the length (inches of the paper, and (2) the selected LPI.

To determine the forms length setting for any printing job, use the formula:

$$\text{FORMS LENGTH} = (\text{LENGTH OF PAPER FORM}) \times (\text{SELECTED LINES PER INCH})$$

EXAMPLES:

- An 11" long form is to be printed at 3 LPI:
Forms Length = $11 \times 3 = 33$
- An 11" long form is to be printed at 6 LPI:
Forms Length = $11 \times 6 = 66$
- A 12" long form is to be printed at 6 LPI:
Forms Length = $12 \times 6 = 72$

Refer to Table 2-2 for other examples.

TO SELECT THIS FEATURE

- Place the printer in feature mode and press **MODE** until the LCD displays the "FORMS L" legend.

The left side of the LCD will display the active form length setting. The right side of the display will show the "FEEDER" legend if a bin mode is active.



FORM LENGTH
SELECTION

001 to 192

MODE

ENTER

STEP

CLEAR

TO CHANGE FORM LENGTH

1. Press **STEP** until the required setting displays on the left side of the LCD.
2. Press **ENTER**. The displayed setting is now operational.

CAUTION

Improper setting of FORMS LENGTH may result in misfeeds when the Automatic Sheet Feeder is being used.

Table 2-2 Form Lengths

		LINES PER INCH SELECTION				
		3 LPI	4 LPI	6 LPI	8 LPI	12 LPI
LENGTH OF PAPER FORM	3"	9	12	18	24	36
	4"	12	16	24	32	48
	6"	18	24	36	48	72
	7"	21	28	42	56	84
	8"	24	32	48	64	96
	11"	33	44	66	88	132
	12"	36	48	72	96	144
14"	42	56	84	112	168	

FEATURE—VERTICAL MARGINS

The vertical margin feature is used to verify and/or set the top and bottom margins on the form.

Top vertical margin may be set as high as line 1, while bottom vertical margin may be set as low as the last line on the form.

When setting vertical margins, be sure:

1. The bottom vertical margin setting is numerically greater than the top margin setting.
2. The bottom margin setting does not exceed the forms length setting.

TO SELECT THIS FEATURE

- Place the printer in feature mode and press **MODE** until the LCD displays the "VER MAR" legend.

A "000" setting, will display on the left. The "FEEDER" legend will display on the right if SF1, SF2, or SF3 mode is active.

TO VERIFY VERTICAL MARGINS

1. To verify the top margin press AND HOLD the **STEP** key. The displayed setting will rapidly advance to the top margin setting.
2. To verify the bottom margin, press **ENTER**, then press AND HOLD the **STEP** key. The displayed setting will rapidly advance to the bottom margin setting.
3. To set new margins, clear the existing margins and set new margins as described below.

TO CLEAR VERTICAL MARGINS

Clearing the vertical margins automatically sets the top vertical margin to line 1, and the bottom vertical margin to the selected forms length.



VERTICAL MARGIN SELECTION

000 to 192

MODE

ENTER

STEP

CLEAR

To clear vertical margins:

1. Press the **MODE** key until the LCD displays "VER MAR" legend and a "000" setting.
2. Press the **CLEAR** key. The "000" setting will not change, but the margins will be reset as described above.

TO ENTER VERTICAL MARGINS

1. Press the **MODE** key until "VER MAR" and "000" setting display.
2. Press the **STEP** key until the required top margin setting displays.
3. Press **ENTER**. This sets the top margin to the line number shown on the display.
4. Press **STEP** until the required bottom margin displays.
5. Press **ENTER**. This sets the bottom margin, and causes the display to return to a "000" setting.
6. Verify new entries using the procedure described above. **BE SURE TO PRESS ENTER WHEN VERIFYING BOTTOM MARGIN.**

FEATURE—CHARACTERS PER INCH

Characters per inch (cpi) determines the width of printed characters as well as their spacing. Changing cpi is only allowed at the start of a line. The feature is used to save paper as a higher cpi prints more characters per line.

TO SELECT THIS FEATURE

- Place the printer in feature mode and press **MODE** until the LCD displays the "CPI" legend.

The active cpi setting will be displayed, and "FEEDER" will show if SF1, SF2, or SF3 mode is active.

TO CHANGE CPI

- Press the **STEP** key until the left side of the LCD displays the required cpi setting.
- Press **ENTER**. The displayed setting has been entered into working memory and is now operational.

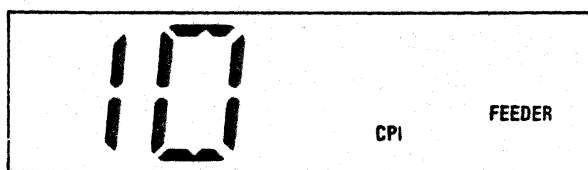

CHARACTERS PER INCH SELECTION

LCD SELECTION

10	10
12	12
13.2	13.2
15	15
16.5	16.5
5	5
6	6
6.6	6.6
7.5	7.5
8.3	8.25

MODE ENTER

STEP CLEAR

FEATURE—LINES PER INCH

Lines per inch (lpi) determines the spacing between lines, not the height of printed characters. Changing lpi also changes the physical locations of vertical margins.

TO SELECT THIS FEATURE

- Place the printer in feature mode and press **MODE** until the LCD displays the "LPI" legend.

The active lpi setting will be displayed, and "FEEDER" will be displayed if SF1, SF2, or SF3 feeder mode is active.

TO CHANGE LPI

- Press the **STEP** key until the left side of the LCD displays the required lpi setting.
- Press **ENTER**. The displayed setting has been entered into working memory and is now operational.

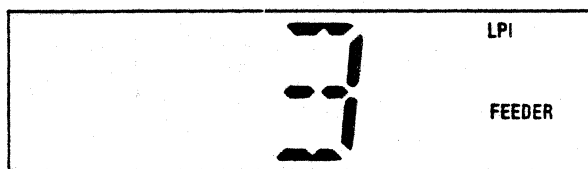

LINES PER INCH SELECTION

LCD SELECTION

3	3
4	4
6	6
8	8
12	12

MODE ENTER

STEP CLEAR

CAUTION
Improper setting of LINES PER INCH may result in misfeeds when the Automatic Sheet Feeder is being used.

FEATURE—COUNTRY CHARACTER SET

This feature permits selection of one of the eight international character sets. The standard character set consists of 96 US ASCII characters.

TO SELECT THIS FEATURE

- Place the printer in feature mode and press **MODE** until the LCD displays the "COUNTRY" legend and the active character set.

You may now set a different character set.

NOTE

This feature cannot be set for the individual feeder bins; thus, the "FEEDER" legend does not display when this feature is active.

TO ENTER COUNTRY CHARACTER SET

- Press **STEP** until the required setting is displayed.
- Press the **ENTER** key to set the new country character set.



COUNTRY CHARACTER SET SELECTION

LCD	SELECTION
USA	USA
FR	FRANCE
UK	UNITED KINGDOM
GER	GERMANY
ITL	ITALY
S/F	SWEDEN/FINLAND
D/N	DENMARK/NORWAY
ESP	SPAIN

MODE

ENTER

STEP

CLEAR

FEATURE—AUTO LINE FEED

If the auto line feed feature is enabled, a line feed is performed on receipt of a carriage return (CR) code or at the end of printing a line. If the CR code is the first character in the buffer the carriage return code is ignored.

TO SELECT THIS FEATURE

- Place the printer in feature mode and press **MODE** until the LCD displays the "AUTO LF" legend and the active setting ("YES" or "NO").

You may now reset the feature.

NOTE

Auto line feed cannot be set for the individual feeder bins.

TO SELECT THE ALTERNATE SETTING

- Press the **STEP** key causing the LCD to display the other setting.
- Press **ENTER**, selecting the new setting.



AUTO LINE FEED SELECTION

LCD	SELECTION
YES	ENABLED
NO	DISABLED

MODE

ENTER

STEP

CLEAR

FEATURE—AUDIO ALARM

The audio alarm, when enabled, sounds a one second tone on a paper empty condition, fault condition, receipt of a BEL code, or setting the top of form, or pressing the **ENTER** or **CLEAR** keys.

TO SELECT THIS FEATURE

- Place the printer in feature mode and press **MODE** until the LCD displays the "ALARM" legend and either a "YES" or "NO" setting.

You may now reset audio alarm.

NOTE

Audio alarm cannot be set for the individual feeder bins.

TO SELECT THE ALTERNATE SETTING

- Press the **STEP** key causing the LCD to display the other setting.
- Press **ENTER**, selecting the new setting.

FEATURE—MEMORY

The printer contains a working memory which stores operational features/configurations while the printer is powered up, and a permanent memory which stores features/configurations while the printer is powered down (refer to paragraph 2.4).

The memory feature can be used to copy the content of either memory into the other.

TO SELECT THIS FEATURE

- Place the printer in feature mode and press **MODE** until the LCD displays the "MEMORY" legend.

You may now copy from one memory into the other.

TO COPY INTO PERMANENT MEMORY

- Press **ENTER**. All parameter settings in working memory have been copied into permanent memory.

TO COPY INTO WORKING MEMORY

- Press **CLEAR**. The parameter settings in permanent memory have been copied into working memory and are now operational.

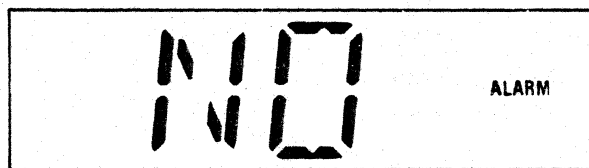

AUDIO ALARM SELECTION

MODE

ENTER

LCD SELECTION

YES ENABLED

NO DISABLED

STEP

CLEAR

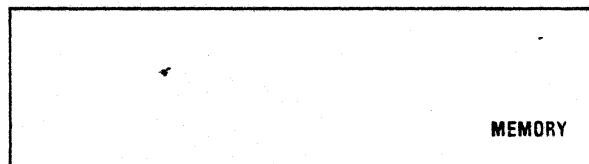

MEMORY SELECTION

MODE

ENTER

NOTE: The left side of the LCD remains clear when **ENTER** or **CLEAR** is pressed.

STEP

CLEAR

NOTE

"Memory" is the last selection in feature mode. Pressing **MODE** with "MEMORY" displayed causes the printer to reenter off-line mode. If mode is pressed a second time, the printer reenters feature mode with the feeder feature selected.

2.6 SELECTING CONFIGURATIONS

Configurations can be verified or set by placing the printer in configuration mode and using **MODE**, **STEP**, **ENTER**, and **CLEAR**.

The LCD displays the "CONFIG" legend whenever the printer is in configuration mode.

The individual configurations and their associated function codes are displayed in the following sequence:

FUNCTION CODE	CONFIGURATION
—	Baud Rate
1	Serial/Parallel
2	Data Bits
3	Parity
4	Buffer Status
5	Printer Status
6	Reverse Channel Polarity
7	Reserved
8	Reserved
9	Inverted Data Strobe
10	Inverted Data Bit 8
11	Bit 8 Control
12	703/ANSI
13	Prime on Select
14	Prime on Delete
15	Print on Paper Motion
16	Page Mode Enable

Function codes are displayed on the left side of the LCD; settings are displayed to the right of the function codes.

SELECTING CONFIGURATION MODE

Configuration mode can only be entered from the feature mode. Pressing **OVRD TEST** while the LCD displays any feature legend will cause the printer to enter configuration mode. The LCD will then display the "CONFIG" legend, indicating configuration mode is selected.

MODE, **STEP**, **ENTER** and **CLEAR** keys may then be used to verify or set configurations.

NOTE

The first configuration selection, **BAUD RATE**, does not have an associated function code; the LCD only displays the operational baud rate setting.

DESELECTING CONFIGURATION MODE

There are two ways to deselect the configuration mode:

- Repeatedly press **MODE** to step through all sixteen function codes. Upon reaching the last code (16), press **MODE** again, which will cause the printer to reenter feature mode.
- Press **ON LINE**. This causes immediate exit from the configuration mode, and places the printer in off-line mode.

The pages which follow explain the individual configurations and detail configuration verification and selection procedures.

CONFIGURATION—BAUD RATE

Baud rate is the speed at which data is transmitted to and from the printer. A large selection of baud rates is available to communicate with the many different systems.

TO VERIFY BAUD RATE SELECTION

1. Enter into the configuration mode by pressing the **OVRD TEST** switch while the printer is in feature mode.
2. The **CONFIG** legend and current baud rate selection is now displayed.
3. To change the baud rate perform the procedure described below.

TO ENTER BAUD RATE SELECTION

1. Press the **STEP** key to advance the display to the required baud rate.
2. Press the **ENTER** key to enter the required baud rate.



BAUD RATE SELECTION

LCD SELECTION

5	50
7	75
11	110
13	134.5
15	150
30	300
60	600
120	1,200
180	1,800
200	2,000
240	2,400
360	3,600
480	4,800
720	7,200
960	9,600
192	19,200

MODE

ENTER

STEP

CLEAR

CONFIGURATION—SERIAL/PARALLEL SELECTION

This set-up feature selects the configuration in which the printer will receive characters.

TO VERIFY SERIAL/PARALLEL SELECTION

1. Enter into the configuration mode by pressing the **OVRD TEST** switch while the printer is in feature mode.
2. Press the **MODE** key until the function code "1" and current serial/parallel selection is displayed.
3. To change the serial/parallel selection perform the procedure described below.

TO ENTER SERIAL/PARALLEL SELECTION

1. Press the **STEP** key to advance the display to the required serial/parallel selection. Display will switch between "1" and "0".
2. Press the **ENTER** key to set the required serial/parallel selection.

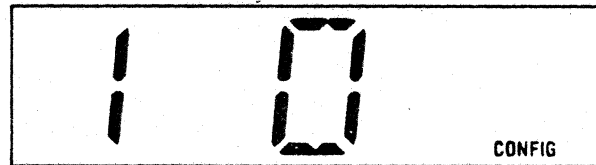

SERIAL/PARALLEL SELECTION

LCD SELECTION

1	SERIAL
0	PARALLEL

MODE

ENTER

STEP

CLEAR

CONFIGURATION—DATA BITS

This set-up feature selects the serial character length.

TO VERIFY DATA BIT SELECTION

1. Enter into the configuration mode by pressing the **OVRD TEST** switch while the printer is in feature mode.
2. Press the **MODE** key until the function code "2" and current data bit selection is displayed.
3. To change the data bit selection perform the procedure described below.

TO ENTER DATA BITS SELECTION

1. Press the **STEP** key to advance the display to the required data bit selection.
2. Press the **ENTER** key to enter the required data bit selection.

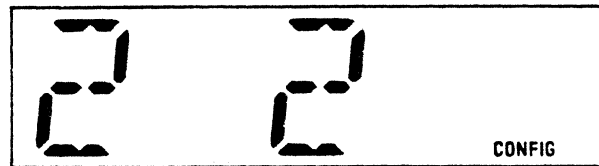

DATA BIT SELECTION

LCD SELECTION

0	5 BITS
1	6 BITS
2	7 BITS
3	8 BITS

MODE

ENTER

STEP

CLEAR

CONFIGURATION—PARITY

Parity allows the serial data to be monitored and thus verifies correct data. If an error in transmission occurs, the printer detects the error and prints @.

TO VERIFY PARITY SELECTION

1. Enter into the configuration mode by pressing the **OVRD TEST** switch while the printer is in feature mode.
2. Press the **MODE** key until the function code "3" and current parity selection is displayed.
3. To change the parity selection perform the procedure described below.

TO ENTER PARITY SELECTION

1. Press the **STEP** key to advance the display to the required parity selection.
2. Press the **ENTER** key to set the required parity selection.

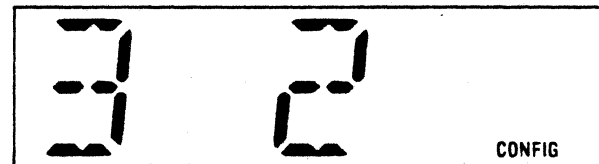

PARITY SELECTION

LCD SELECTION

0	NONE (Disabled)
1	ODD
2	INVALID
3	EVEN

MODE

ENTER

STEP

CLEAR

CONFIGURATION—BUFFER STATUS

This set-up feature selects the configuration to report the buffer status while in serial communications. The status is indicated by one of four selections; reverse channel (RC), data terminal ready (DTR), transmitted data (X-ON/X-OFF), and no status returned. Table 2-3 below indicates the buffer status for each configuration.

TO VERIFY BUFFER STATUS SELECTION

1. Enter into the configuration mode by pressing the **OVRD TEST** switch while the printer is in feature mode.
2. Press the **MODE** key until the function code "4" and current buffer status is displayed.
3. To change the buffer status selection perform the procedure described below.

TO ENTER BUFFER STATUS SELECTION

1. Press the **STEP** key to advance the display to the required buffer status selection.
2. Press the **ENTER** key to set the required buffer status.

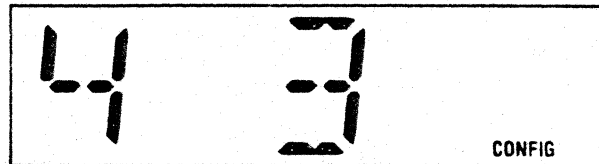

BUFFER STATUS SELECTION

LCD SELECTION

- 0 NONE
- 1 REVERSE CHANNEL
- 2 DTR
- 3 X-ON/X-OFF

MODE

ENTER

STEP

CLEAR

Table 2-3 Buffer Status

CONFIGURATION	STATUS	INDICATION
BUFFER STATUS	BUFFER FULL BUFFER EMPTY	REVERSE CHANNEL Dependent on the selection of reverse channel polarity.
BUFFER STATUS	BUFFER FULL BUFFER EMPTY	DTR Active High DTR Active Low
BUFFER STATUS	BUFFER FULL BUFFER EMPTY	X-OFF X-ON
BUFFER STATUS	BUFFER FULL BUFFER EMPTY	NONE NONE

CONFIGURATION—PRINTER STATUS

This set-up feature selects the configuration to report the printer status while in serial communications. The status is indicated by one of four selections; reverse channel (RC), data terminal ready (DTR), transmitted data (X-ON/X-OFF), and no status returned. Table 2-4 below indicates the printer status for each configuration.

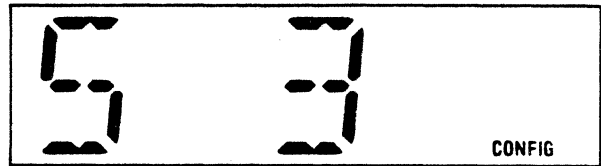

PRINTER STATUS SELECTION

LCD SELECTION

- 0 NONE
- 1 REVERSE CHANNEL
- 2 DTR
- 3 X-ON/X-OFF

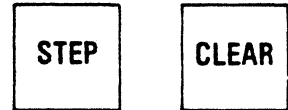
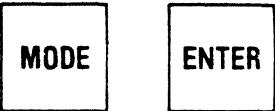

TO VERIFY PRINTER STATUS SELECTION

1. Enter into the configuration mode by pressing the **OVRD TEST** switch while the printer is in feature mode.
2. Press the **MODE** key until the function code "5" and current printer status is displayed.
3. To change the printer status selection perform the procedure described below.

TO ENTER PRINTER STATUS SELECTION

1. Press the **STEP** key to advance the display to the required printer status selection.
2. Press the **ENTER** key to set the required printer status.

Table 2-4 Printer Status

CONFIGURATION	STATUS	INDICATION
PRINTER STATUS	SELECT DESELECT OR PAPER EMPTY	REVERSE CHANNEL Dependent on the selection of reverse channel polarity.
PRINTER STATUS	SELECT DESELECT OR PAPER EMPTY	DTR Active High DTR Active Low
PRINTER STATUS	SELECT DESELECT OR PAPER EMPTY	X-ON X-OFF
PRINTER STATUS	SELECT DESELECT OR PAPER EMPTY	NONE NONE

CONFIGURATION—REVERSE CHANNEL POLARITY

This set-up feature sets the busy state of reverse channel polarity at either active low or active high.

TO VERIFY REVERSE CHANNEL POLARITY SELECTION

1. Enter into the configuration mode by pressing the **OVRD TEST** switch while the printer is in feature mode.
2. Press the **MODE** key until the function code "6" and current reverse channel polarity selection is displayed.
3. To change the reverse channel polarity selection perform the procedure described below.

TO ENTER REVERSE CHANNEL POLARITY SELECTION

1. Press the **STEP** key to advance the display to the required reverse channel polarity selection.
2. Press the **ENTER** key to set the required reverse channel polarity selection.

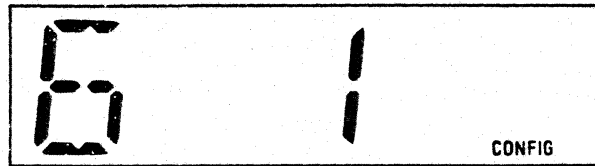

REVERSE CHANNEL POLARITY SELECTION

LCD	SELECTION
0	ACTIVE LOW
1	ACTIVE HIGH

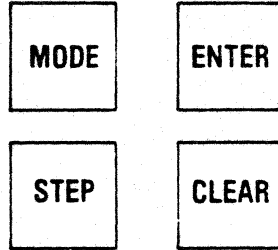

CONFIGURATION—INVERTED DATA STROBE

This configuration selects the level (normal or inverted) of data strobe which transfers the incoming parallel data into the printer.

TO VERIFY INVERTED DATA STROBE SELECTION

1. Enter into the configuration mode by pressing the **OVRD TEST** switch while the printer is in feature mode.
2. Press the **MODE** key until the function code "9" and current inverted data strobe selection is displayed.
3. To change the inverted data strobe selection perform the procedure described below.

TO ENTER INVERTED DATA STROBE SELECTION

1. Press the **STEP** key to advance the display to the required inverted data strobe selection.
2. Press the **ENTER** key to set the required inverted data strobe selection.

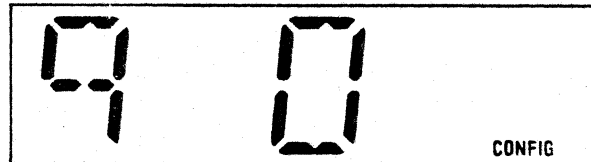

INVERTED DATA STROBE SELECTION

LCD	SELECTION
0	NORMAL
1	INVERTED

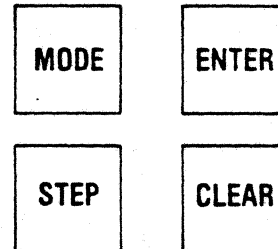

CONFIGURATION—INVERTED DATA BIT 8

This feature sets bit 8 to select the alternate character set or to be ignored.

TO VERIFY INVERTED DATA BIT 8 SELECTION

1. Enter into the configuration mode by pressing the **OVRD TEST** switch while the printer is in feature mode.
2. Press the **MODE** key until the function code "10" and current inverted data bit 8 selection is displayed.
3. To change the inverted data bit 8 selection perform the procedure described below.

TO ENTER INVERTED DATA BIT 8 SELECTION

1. Press the **STEP** key to advance the display to the required inverted data bit 8 selection. Display will switch between "0" and "1".
2. Press the **ENTER** key to set the required inverted data bit 8 selection.

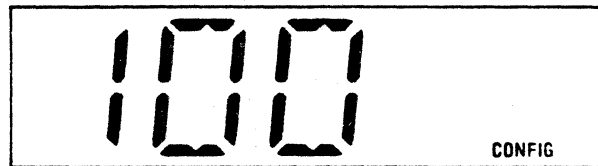

INVERTED DATA BIT 8 SELECTION

LCD SELECTION
0 NORMAL
1 INVERTED

MODE

ENTER

STEP

CLEAR

CONFIGURATION—BIT 8 CONTROL

This feature controls bit 8 in the printer. If set to Escape Control of bit 8, bit 8 is controlled by ESC 3, ESC and/or SO/SI and is used for character set selection.

TO VERIFY BIT 8 CONTROL SELECTION

1. Enter into the configuration mode by pressing the **OVRD TEST** switch while the printer is in feature mode.
2. Press the **MODE** key until the function code "11" and current bit 8 control selection is displayed.
3. To change the bit 8 control selection perform the procedure described below.

TO ENTER BIT 8 CONTROL SELECTION

1. Press the **STEP** key to advance the display to the required bit 8 control selection.
2. Press the **ENTER** key to set the required bit 8 control selection.

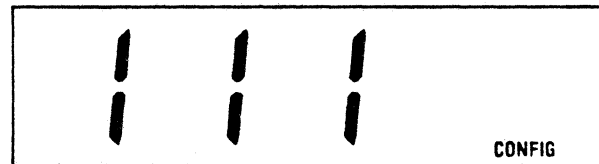

BIT 8 CONTROL SELECTION

LCD SELECTION

0 IGNORE BIT 8
1 NORMAL CONTROL
2 ESCAPE CONTROL
3 NORMAL CONTROL

MODE

ENTER

STEP

CLEAR

CONFIGURATION—703/ANSI

This set-up feature selects the configuration in which control codes are interpreted. Some control codes are acknowledged in 703 mode only, some in the ANSi mode and others in both the 703 and ANSi mode. (See Table 10-1).

TO VERIFY 703/ANSI SELECTION

1. Enter into the configuration mode by pressing the **OVRD TEST** switch while the printer is in feature mode.
2. Press the **MODE** key until the function code "12" and current 703/ANSI selection is displayed.
3. To change the 703/ANSI selection perform the procedure described below.

TO ENTER 703/ANSI SELECTION

1. Press the **STEP** key to advance the display to the required 703/ANSI selection.
2. Press the **ENTER** key to set the required 703/ANSI selection.

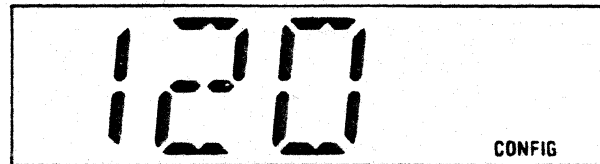

703/ANSI SELECTION

LCD SELECTION

0	703L
1	ANSI

MODE

ENTER

STEP

CLEAR

CONFIGURATION—PRIME ON SELECT

When prime on select is enabled and the printer is selected, the print head is returned to the left margin and input buffer cleared.

TO VERIFY PRIME ON SELECT SELECTION

1. Enter into the configuration mode by pressing the **OVRD TEST** switch while the printer is in feature mode.
2. Press the **MODE** key until the function code "13" and current prime on select selection is displayed.
3. To change the prime on select selection perform the procedure described below.

TO ENTER PRIME ON SELECT SELECTION

1. Press the **STEP** key to advance the display to the required prime on select selection. Display will switch between "0" and "1".
2. Press the **ENTER** key to set the required prime on select selection.

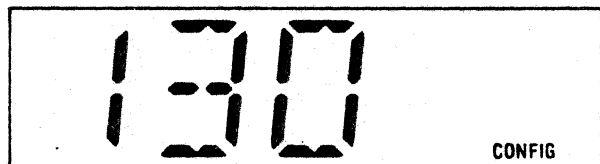

PRIME ON SELECT SELECTION

LCD SELECTION

0	DISABLED
1	ENABLED

MODE

ENTER

STEP

CLEAR

CONFIGURATION—PRIME ON DELETE

When prime on delete is enabled and a delete code (DEL) is received, the print head is returned to the left margin and the input buffer cleared.

TO VERIFY PRIME ON DELETE SELECTION

1. Enter into the configuration mode by pressing the **OVRD TEST** switch while the printer is in feature mode.
2. Press the **MODE** key until the function code "14" and current prime on delete selection is displayed.
3. To change the prime on delete selection perform the procedure described below.

TO ENTER PRIME ON DELETE SELECTION

1. Press the **STEP** key to advance the display to the required prime on delete selection. Display will switch between "0" and "1".
2. Press the **ENTER** key to set the required prime on delete selection.



PRIME ON DELETE SELECTION

LCD	SELECTION
0	DISABLED
1	ENABLED

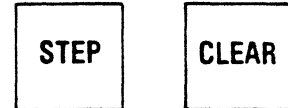
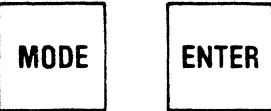

CONFIGURATION-PRINT ON PAPER MOTION

Print on paper motion can be configured one of three ways. An example of each is shown below:

DATA SENT: A <LF> B <LF> C <CR>

1. Paper motion causes print with carriage return (LCD 1)

A
B
C

2. Paper motion causes print without carriage return (LCD 2)

A B C

3. Paper motion does not cause print (LCD 0 or 3)

<LINE FEED>
<LINE FEED>
ABC

TO VERIFY PRINT ON PAPER MOTION SELECTION

1. Enter into the configuration mode by pressing the **OVRD TEST** switch while the printer is in the feature mode.
2. Press the **MODE** key until the function code "15" and current print on paper motion selection is displayed.
3. To change the print on paper motion selection perform the procedure described below.



PRINT ON PAPER MOTION SELECTION

LCD	SELECTION
1	PAPER MOTION CAUSES PRINT WITH CR
2	PAPER MOTION CAUSES PRINT WITH NO CR
3 or 0	PAPER MOTION DOES NOT CAUSE PRINT

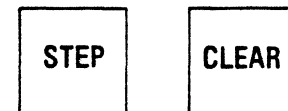
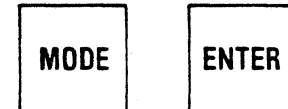

TO ENTER PRINT ON PAPER MOTION SELECTION

1. Press the **STEP** key to advance the display to the required print on paper motion selection..
2. Press the **ENTER** key to set the required print on paper motion selection.

CONFIGURATION—PAGE MODE ENABLE

The page mode configuration, when enabled, allows the printer to receive up to 4096 characters after a "STX" code and before an "ETX" code including control codes without going busy. The page mode is used for graphics data or a high speed page dump.

TO VERIFY PAGE MODE SELECTION

1. Enter into the configuration mode by pressing the **OVRD TEST** switch while the printer is in feature mode.
2. Press the **MODE** key until the function code "16" and current page mode selection is displayed.
3. To change the page mode selection perform the procedure described below.

TO ENTER PAGE MODE SELECTION

1. Press the **STEP** key to advance the display to the required page mode selection. Display will switch between "0" and "1".

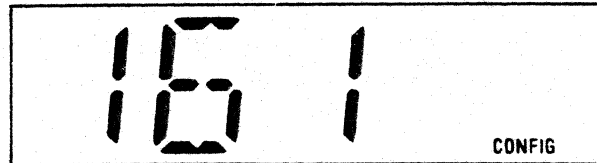

PAGE MODE SELECTION

LCD SELECTION

0	DISABLED
1	ENABLED

MODE

ENTER

STEP

CLEAR

2. Press the **ENTER** key to set the required page mode selection.

NOTE

Page Mode Enable is the last configuration. To reselect off-line mode, press **ON LINE**; to reselect feature mode, press **MODE**.

2.7 FACTORY SETTINGS

The printer is shipped from Centronics with the following features/configurations selected.

NOTE

Function codes 7 and 8 in the configuration mode are reserved for factory testing.

Table 2-5 Factory Settings

FEATURE	SELECTION
Feeder	Off
Horizontal Tabs	16 Tabs (Every 8 Columns)*
Vertical Tabs	11 Tabs (Every 6 Lines)*
Forms Length	66 Lines*
Characters Per Inch	10 CPI*
Lines Per Inch	6 LPI*
Vertical Margins	Top, Line 1; Bottom, Line 66*
Country Character Set	USA
Auto Line Feed	Disabled
Alarm	Enabled
CONFIGURATION	SELECTION
Baud Rate	9600 Baud
Serial/Parallel	Parallel
Data Bits	7 Data Bits
Parity	None
Buffer Status	X-ON/X-OFF
Printer Status	X-ON/X-OFF
Reverse Channel Polarity	Active High
Inverted Data Strobe	Normal
Inverted Data Bit 8	Normal
Bit 8 Control	Normal
703/ANSI	703 Compatible
Prime on Select	Disabled
Prime on Delete	Disabled
Print on Paper Motion	Print With No Carriage Return
Page Mode Enable	Enabled

*These parameters are also stored for each of the bins for use with the Automatic Sheet Feeder.

SECTION 3

PAPER LOADING/RIBBON REPLACEMENT

3.1 GENERAL

This section details the procedures for loading paper, replacing the ribbon, and adjusting the print head for optimum print quality.

NOTE

The following procedures are performed from the front of the printer.

3.2 INITIAL LOADING, FANFOLD FORMS

The following procedures describe the first time loading of either single part or multi-part fanfold forms once the printer is installed. Refer to Figure 3-1 and perform the following steps:

NOTE

The optional sheet feeder must be tilted back or removed to load fanfold forms.

1. Move the forms lever to the "LOAD" position.
2. Pull the head adjustment lever towards front of printer to its maximum position.
3. Unsnap and lift the rear cover from the printer.
4. Locate the left and right pin feed tractors.
5. Loosen the left pin feed tractor locking lever and slide the tractor to the leftmost position. Tighten the locking lever to secure the tractor.
6. Place the forms to be installed slightly behind the printer.
7. Open the left and right tractor paper guides.
8. Install the forms onto the drive pins of the left pin feed tractor and close the left tractor paper guide.

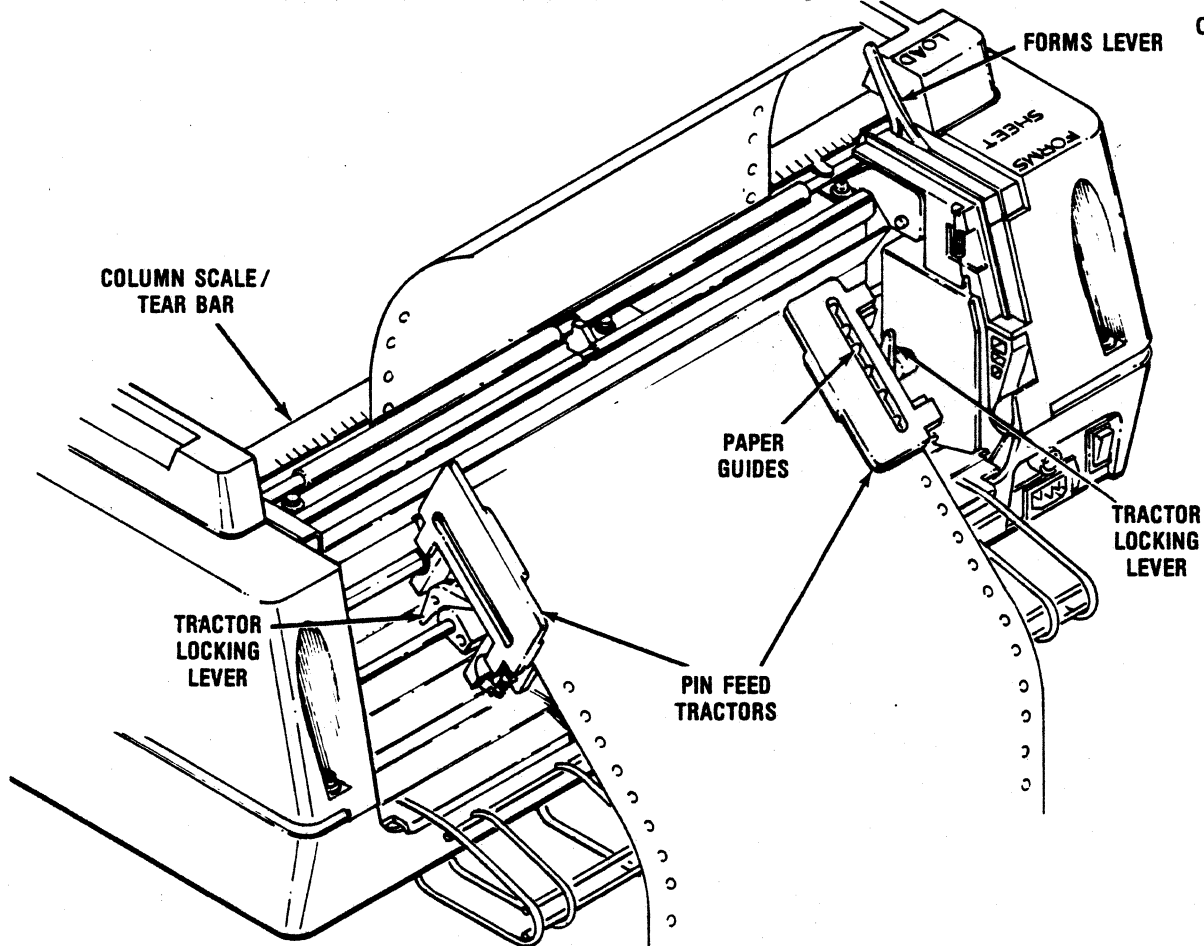

Figure 3-1 Loading Fanfold Forms

9. Loosen the tractor locking lever on the right pin feed tractor and slide the tractor left or right to accommodate the forms width. Once adjusted, tighten the locking lever to secure the tractor.
10. Install the forms onto the drive pins of the right pin feed tractor and close the paper guide.
11. Turn the printer power on, set feeder feature "OFF", and hold the LF switch depressed which loads the forms into the printer.
12. Release the LF when the top edge of the form is about 3" above the column scale/tear bar.
13. Gently pull the form across the column scale/tear bar (see Figure 3-2).

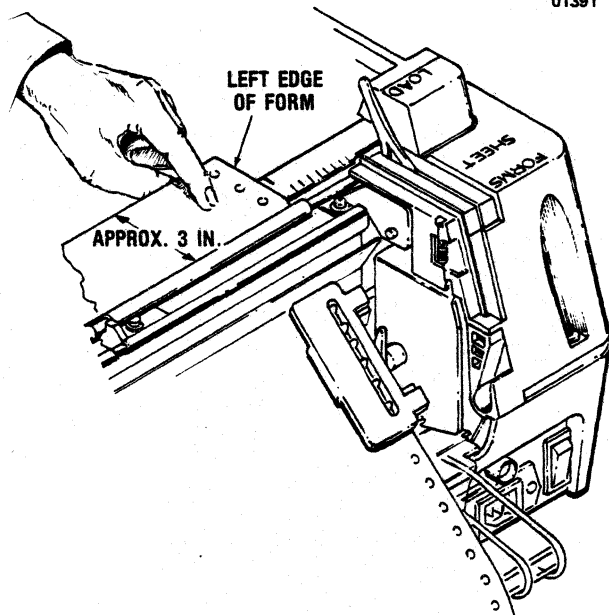

Figure 3-2 Fanfold Alignment

14. Note how the left edge of your form aligns with the three fanfold calibration marks which are shown in Figure 3-3.
15. If the edge of the form lines up with the middle calibration, the left margin of the printed form will be approximately 5/8" from the edge of the paper (refer to dimension B, Fig. 3-3). Alignment with either of the outside calibrations offsets the 5/8" margin by 1/10".
16. To adjust for the margin width you want, release both tractor locking levers and move

the tractors to the left or right until the paper lines up with the proper calibration, then lock tractors in place.

17. Place the forms lever in the "FORMS" position, and set TOF per paragraph 3.3.

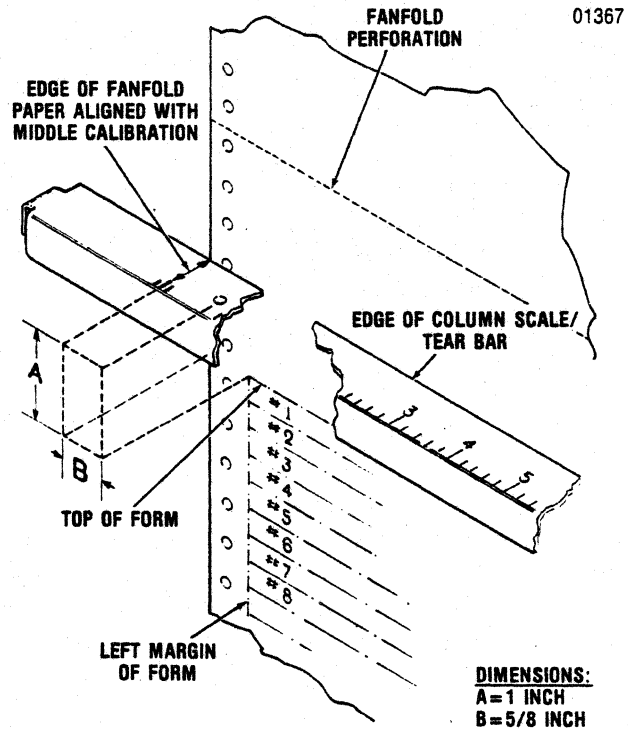

Figure 3-3 Margin Adjustment

3.3 SETTING TOF; FANFOLD FORMS

Top of form (TOF) must be set after initial loading of fanfold paper. Setting TOF for fanfold paper involves:

1. Moving paper up or down until the sector of paper which is to be the first printable line is positioned in front of the printhead.
2. Pressing the **SET TOF** switch.

Figure 3-3 shows the printer loaded with paper just prior to setting TOF. Note that several consecutively numbered lines are shown outlined on the paper. These lines show where the first few printable lines will be positioned on the paper if the **SET TOF** switch is pressed with paper loaded as shown. Particularly note that the top of form (the top edge of the first printable line) will be set 1" **below** the edge of the column scale/tear bar (dimension A).

NOTE

Pressing **SET TOF** sets the top of form at a point 1" below the tear bar.

Pressing **SET TOF** with paper positioned as shown in Figure 3-3 sets top of form several inches below the paper perforation. To set TOF just below the perf, move paper until the perf is almost 1" below the tear bar, and then press **SET TOF**.

The following is suggested as a means for setting TOF just below a fanfold perforation:

NOTE

Ensure the feeder feature is set "OFF" before setting TOF.

1. Load/align the paper per paragraph 3.2.
2. Move the paper until the perforation is positioned **just above** the edge of the scale/tear bar.
3. Compute a **temporary** forms length, using the formula:
Temporary Forms Length =
[perf to perf distance (in inches) × lines per inch selection] – [lines per inch selection]
Example:
Assume the fanfold forms measure 11" from perf to perf, and the operator has selected a density of 6 lines per inch. Using the formula, the temporary forms length would be:
[11 × 6] – [6], or 60.
4. Press **MODE** until the Forms Length legend displays.
5. Press **STEP** until the number corresponding to the temporary forms length displays.
6. Press **ENTER**, loading the temporary forms length into working memory.
7. Press **ON LINE** to clear the LCD.
8. Press **SET TOF**, setting the **temporary** top of form.
9. Press **FORM FEED**.

The paper will advance and stop with the next perforation positioned **just less than** one inch below the tear bar, i.e. in the exact position for setting a top of form just below the perf.

Set the **permanent** TOF by performing the following steps:

10. Compute the permanent forms length using the formula:
Permanent Forms Length =
[perf to perf distance (in inches) × lines per inch selection]
Using the previous example, the permanent forms length equals 66.
11. Press **MODE** until the Forms Length legend displays.
12. Press **STEP** until the number corresponding to the permanent forms length displays.
13. Press **ENTER**, loading the permanent forms length into working memory.
14. Press **ON LINE** to clear the LCD.
15. Press **SET TOF**. Your top of form has been set for just below the perforation.
16. Perform the printhead adjustment per paragraph 3.10.
17. Install the rear cover retaining tabs into the body cover slots and snap the top cover closed.
18. Press **ON LINE** to enable the printer to receive data.

3.4 RELOADING FANFOLD FORMS

The Model 358-3,-4 prints until the last fanfold form passes through the paper empty switch on the left pin feed tractor. When out of paper, printing stops, the **FAULT** indicator lights, the audio alarm sounds and the printer deselected. To reload fanfold forms perform the following steps:

NOTE

To move the last form through the printer on a paper empty condition hold the **OVRD TEST** switch depressed and select the printer which allows the printer to print the last form. **DO NOT TURN POWER OFF TO RELOAD FORMS.**

1. With the feeder tilted back or removed, move the forms lever to the "LOAD" position.

NOTE

Before performing step 2 note the position of the head adjustment lever. If installing the same form as previous, return the lever to this position once the form is installed.

2. Pull the head adjustment lever towards the front of the printer to its maximum position.

3. Unsnap and lift the rear cover from the printer.

4. Open the left and right tractor guides and load the forms onto the drive pins of the tractors.

5. Close the tractor guides.

6. Hold the LF switch depressed, which loads paper up into the printer.

7. Set TOF per paragraph 3.3.

8. Place the forms lever in the "FORMS" position.

9. If a different form thickness is installed perform the print head impression adjustment.

10. Install the rear cover retaining tabs into the body cover slots and snap the top closed.

11. Press the **ON LINE** switch to enable the printer to receive data.

3.5 INITIAL LOADING, CUT SHEET FORMS

The printer is designed to allow semi-automatic insertion of cut sheet forms and documents. The following procedure describes the first time loading of either single or multi-part cut sheet forms once the printer is installed. Refer to Figure 3-4 and perform the following steps:

1. Unsnap the top portion of the rear cover and place in the open position and slide the

01393

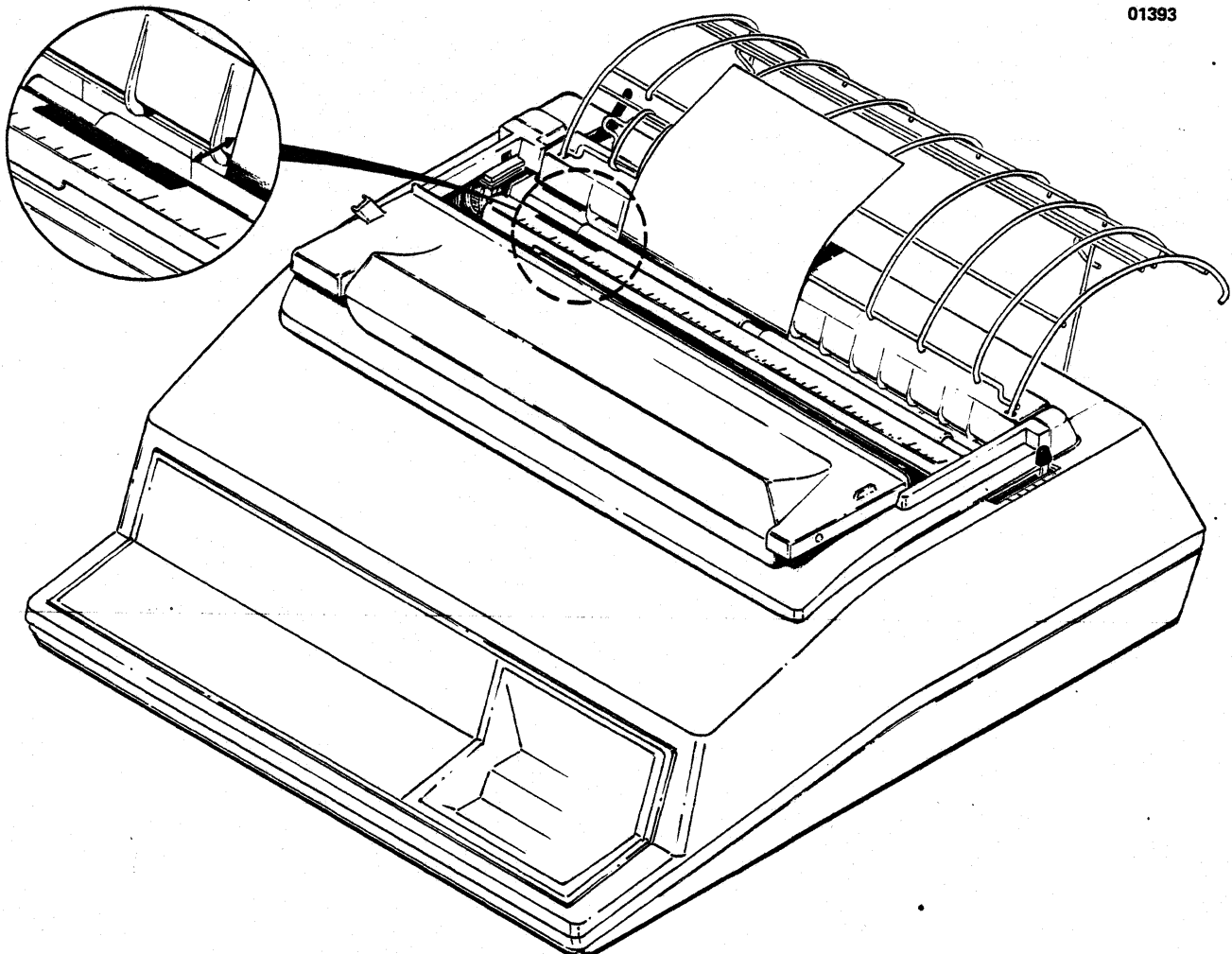

Figure 3-4 Loading Cut Sheet Forms

left/right pin feed tractors to the extreme left/right positions. Once the tractors are positioned snap the rear cover closed.

2. Turn the printer power on and enable the cut sheet mode by pressing the **CUT SHEET MODE** switch on the control panel.
3. Set the form length and lpi to match the length of the cut sheet paper, using the formula:
$$\text{FORMS LENGTH} = (\text{SHEET LENGTH}) (\text{LPI})$$

EXAMPLE:
Assume an 11" long sheet of paper, to be printed at 6 lpi. Plugging into the formula:
$$\text{FORMS LENGTH} = (11) (6)$$
$$\text{FORMS LENGTH} = 66$$

Forms length should be set for 66; lpi should be set for 6 (refer to Section 2 for instructions on entering these features.)
4. Move the forms lever to the "LOAD" position.
5. Pull the head adjustment lever towards the front of the unit, to its maximum position.
6. Insert the bottom edge of the cut sheet form between the rollers on the column scale and the paper drive roller until the mechanical stops prevent further insertion.
7. Slide the cut sheet form left or right until the left edge of the form aligns with the right edge of the cut sheet load indicator (see Fig. 3-4).

NOTE

Alignment of the left edge of the form and the right edge of the indicator sets a 3/4" left margin on the form.

8. Place the forms lever in the "SHEET" position.
9. Press the **CUT SHEET INSERT** switch on the control panel, which loads the cut sheet form into the printer.

NOTE

When forms length and lpi are set according to the formula given in step 3, paper halts with the upper edge of the sheet even with the top of the column scale/tear bar.

10. Press **SET TOP**. This sets the top of form 1" below the top edge of the sheet.

Cut sheet top of form must be set 1" below the top of the sheet because the paper feed mechanism (which holds the paper in place) is located **above** the print head. Losing an inch of form means the number of printable lines for a given form will always be fewer than the number of lines selected for forms length.

Use the following formula to determine the number of printable lines for a cut sheet form:

$$\text{PRINTABLE LINES} = (\text{SHEET LENGTH} \times \text{LPI}) - (\text{LPI})$$

EXAMPLE:

Again, assume an 11" long sheet of paper, to be printed at 6 lpi. Plugging into the formula:

$$\text{PRINTABLE LINES} = (11 \times 6) - (6)$$

$$\text{PRINTABLE LINES} = 60$$
 . . . or 6 lines fewer than selected forms length of 66.

11. Perform the print head impression adjustment per paragraph 3.11.
12. Press the **ON LINE** switch, to enable the printer to receive data.

3.6 RELOADING CUT SHEET FORMS

To insert additional forms refer to Figure 3-4 and perform the following steps:

NOTE

Before performing step 1 note the position of the head adjustment lever. If installing the same form as previous return the lever to this position once the form is installed. **DO NOT TURN POWER OFF TO RELOAD FORMS.**

1. Pull the head adjustment lever towards the front of the printer to its maximum position.
2. Place the forms lever in "LOAD" position.
3. Insert the bottom edge of the cut sheet form between the rollers on the column scale and the paper drive roller until the mechanical stops prevent further insertion.
4. Slide the cut sheet form left or right until the left edge of the form aligns with the right edge of the cut sheet load indicator.
5. Place the forms lever in the "SHEET" position.

6. Press the **CUT SHEET INSERT** switch on the control panel which loads the cut sheet form into the printer.
7. If a different size form is installed perform the print head impression adjustment per paragraph 3.11.
8. Press the **ON LINE** switch on the control panel to enable the printer to receive data.

3.7 PRINT STAND PAPER LOADING

Printers equipped with the optional print stand are loaded with fanfold forms by performing the following steps:

1. Refer to Figure 3-5 and position an open box

of fanfold forms at the base of the print stand, as shown in the illustration.

2. Refer to paragraph 3.2 and perform steps 1 through 7.
3. Guide the fanfold paper out of the box, through the opening between the wirebasket and the stand uprights, over the lower paper guide and onto the drive pins of the left pin feed tractor.
4. Close the left tractor paper guide.
5. Refer to paragraph 3.2 and perform steps 9 through 17.
6. Set TOF per paragraph 3.3.

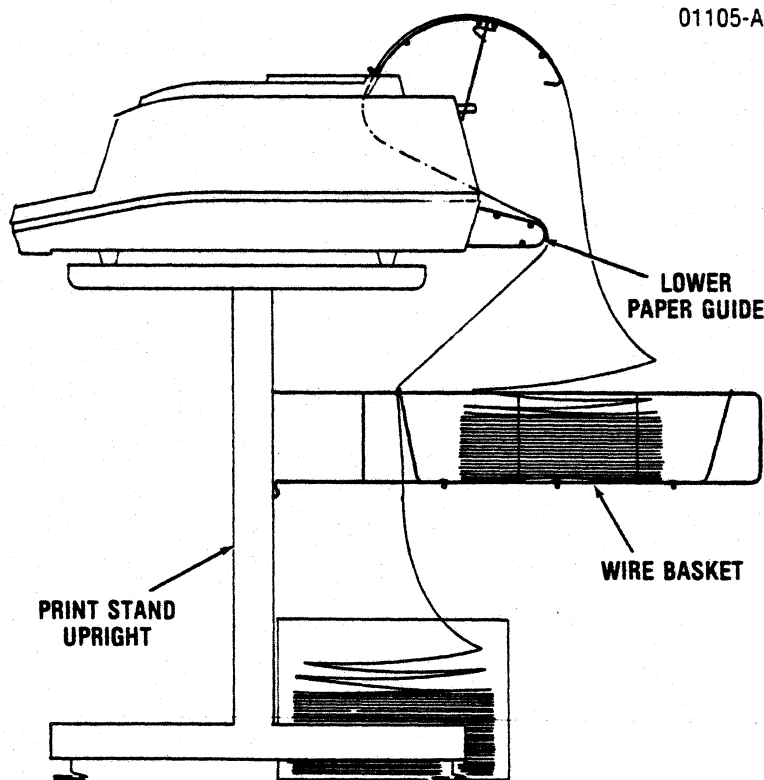
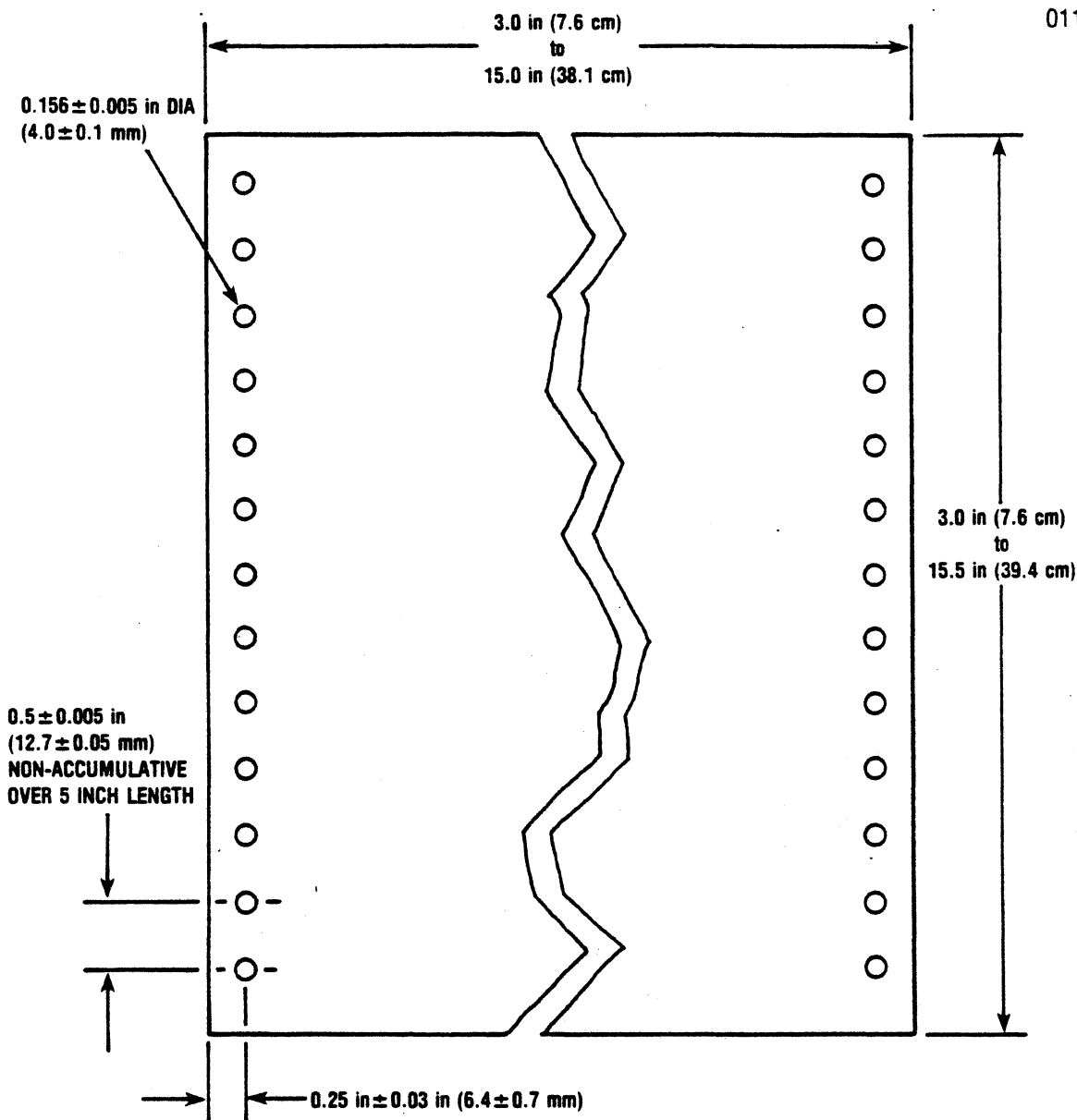

Figure 3-5 Paper Travel, Print Stand Loading

**NOTES**

- Forms may be glued or crimped.
- Form thickness should not exceed .0204 in. (0.52 mm) when glued.
- Crimps must be spaced a minimum of 2.0 in. (508 mm) along both edges of the forms and not within 0.5 in. (12.7 mm).
- Metal staples cannot be used.
- Thickness:
Single Part—0.010 in (0.25 mm) maximum
Multi-Part—0.0204 in. (0.52 mm) maximum, up to six part with carbon.
- Weight:
Single Part—15-20 lb. bond (56 g/m² to 75 g/m²)
Multi-Part—

Ply	Paper	Carbon
2	15 lb (56 g/m ²) bond	#7 (16.5 g/m ²) tissue
3	15 lb (56 g/m ²) bond 12 lb (45 g/m ²) bond	#7 (16.5 g/m ²) tissue
4-6	12 lb (45 g/m ²) except last copy 15 lb (56 g/m ²)	#7 (16.5 g/m ²) tissue

Figure 3-6 Fanfold Form Design

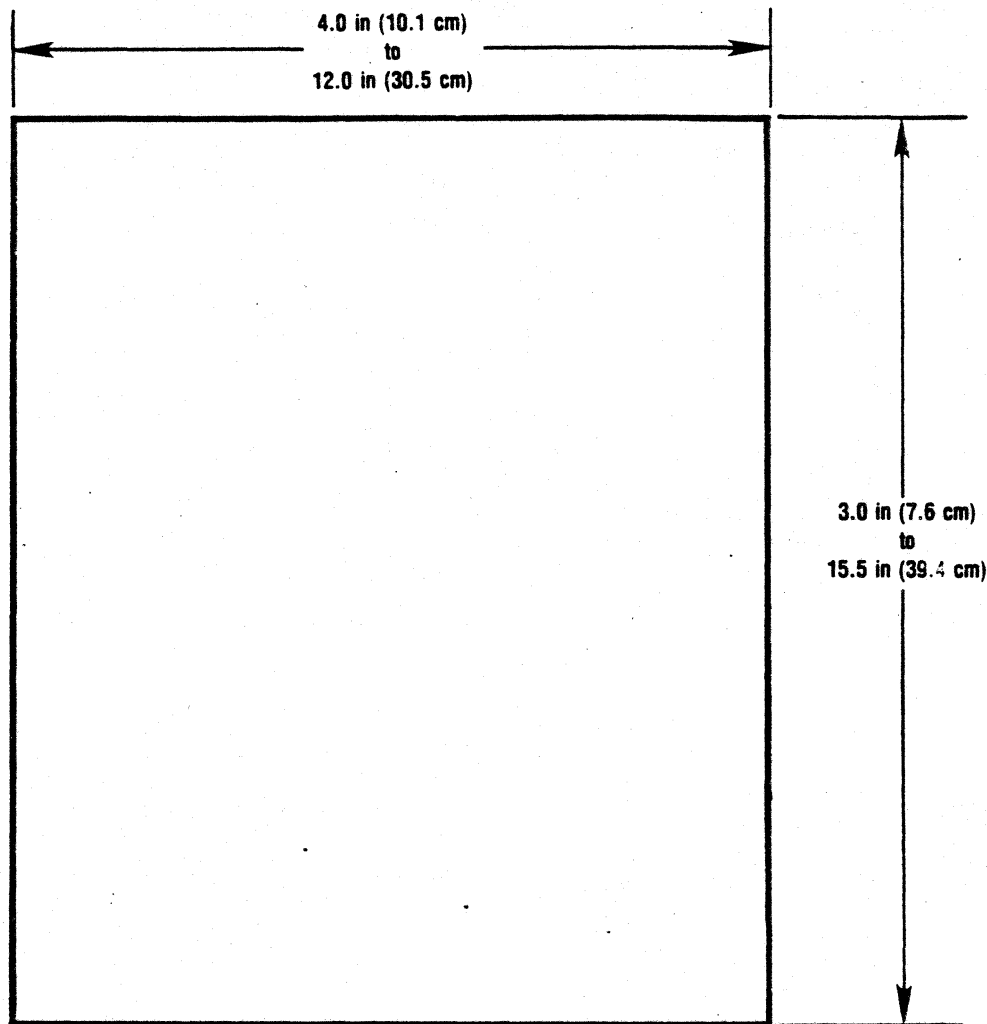

NOTES

1. Multi-part forms may be glued on the top or bottom.
2. Stapled forms may not be used.
3. Split forms with each side containing a different thickness or number of sheets are not recommended.
4. On multi-part forms, use 12 lb (45 g/m²) as first copies with heaviest copy last.
6. On multi-part forms over four parts, use a 5 lb (12 g/m²) carbon tissue.
7. Thickness/Weight
 Single Part—20 lb paper (70 g/m²) minimum
 Multi-Part—0.024 in (0.52 mm) maximum

Ply	Paper	Carbon
2	15 lb (56 g/m ²) bond	#7 (16.5 g/m ²) tissue
3	15 lb (56 g/m ²) bond 12 lb (45 g/m ²) bond	#7 (16.5 g/m ²) tissue
4-8	12 lb (45 g/m ²) except last copy 15 lb (56 g/m ²)	#7 (16.5 g/m ²) tissue

Figure 3-7 Cut Sheet Forms Design

3.8 FORMS DESIGN

Figures 3-6 and 3-7 detail information on fan-fold

forms and cut sheet forms design. The forms should conform to the specifications, if not, paper handling problems may occur.

3.9 FORM LOADING, SHEET FEEDER

INITIAL LOADING—Perform the following steps to load paper from bin 1, 2, or 3 of the feeder:

1. Tilt the feeder back (refer to feeder manual).
2. Move the forms lever to “SHEET” position.
3. Ensure fanfold forms are not loaded.
4. Slide the left/right pinfeed tractors to extreme left/right positions.
5. Return the feeder to operating position.
6. Power up the printer.
7. Press **MODE**. The LCD will display the “FEEDER” legend and the “OFF”, “SF1”, “SF2”, or “SF3” setting.
8. Press **STEP** until the required bin setting (“SF1”, “SF2” or “SF3”) appears on the LCD.
9. Press **ENTER**. The **CUT SHEET** indicator will go on, indicating the printer is selected for the mode displayed on the LCD.
10. Press **FORM FEED**. This loads one form from the selected bin into the printer.
11. Press **ON LINE** to clear the LCD and return to off-line mode.
12. Press **ON LINE** again to select the printer.

Once the printer is selected, forms may be ejected and reloaded via control codes/escape sequences. Refer to Section 10 for details.

EJECTING PRINTED FORMS/RELOADING—

Perform the following steps to eject a printed form and reload from a feeder bin.

TO EJECT AND RELOAD FROM THE SAME BIN:

1. Deselect the printer.
2. Press **FORM FEED**. This ejects the printed form and reloads from the same bin.

TO EJECT AND LOAD FROM A DIFFERENT BIN:

1. Deselect the printer.
2. Press **MODE** to enter feeder feature mode.

3. Press **STEP** until the required bin mode displays on the LCD.
4. Press **ENTER** to select the displayed mode.
5. Press **FORM FEED**. This ejects the printed form and loads one form from the newly selected bin.
6. Press **ON LINE** to deselect feature mode and reenter off-line mode.
7. Press **ON LINE** again to select the printer.

CLEARING THE PAPER PATH—Perform the following steps to eject a printed form without reloading:

1. Deselect the printer.
2. Press **MODE** to select feature mode.
3. Press **STEP** until the feeder “OFF” setting displays.
4. Press **ENTER**. This deselects the feeder and places the printer in single cut sheet mode.

NOTE

The **CUT SHEET** indicator will remain “ON” because the printer is in single sheet mode. Parameters set for fanfold/cut sheet mode are now active.

5. Press **FORM FEED** to eject sheet.

FEEDER LOADING NOTES—Remember the following when loading from the feeder:

- To avoid misfeeds/paper jams, the printer logic will not permit SF1, 2, or 3 feature mode to be selected when fanfold forms are loaded. If you attempt to locally select the feeder with fanfold paper loaded, you’ll find that **STEP** won’t function.
- Upon determining a paper empty/paper jam condition, the printer will automatically deselect. The audio alarm will sound and the fault indicator will go “ON”. “SF1”, “SF2”, or “SF3” will display, indicating which bin has caused the problem. After correcting the problem, press **FORM FEED**. A new form will be loaded from the selected bin. You may now select the printer and continue printing operations.
- Set margins as described in paragraph 3.5. Use the feeder horizontal adjustment knob (refer to the sheet feeder manual) to adjust forms to the left or right.

3.10 RIBBON CASSETTE REPLACEMENT

The printer accepts black (standard) and color (optional) ribbon cassettes. The same basic procedure is used to replace standard and optional cassettes. To replace a cassette, refer to Figure 3-8 and perform the following steps:

UNPACK THE NEW CASSETTE

1. Remove the new cassette from the shipping carton and set cassette aside.
2. Remove the two corner guides from the carton and set the guides aside.

REMOVE THE USED CASSETTE

NOTE

The optional sheet feeder must be tilted back or removed to replace the ribbon cassette.

1. Lift the top cover up and off the printer.
2. Unsnap the top portion of the rear cover and place in the open position.
3. Ensure the print head is at the extreme left margin.
4. Place the forms lever in the "LOAD" position.
5. Lift the column scale into the up position.
6. Place the forms lever into "SHEET" or "FORMS" position.

NOTE

Before performing step 7 note the position of the head adjustment lever. Once the new ribbon cassette is installed return the lever to this position.

7. Pull the head adjustment lever towards the front of the printer to its maximum position.
8. Move the print head to the middle of the printer.
9. Detach the shifter guide from the print head by (1) pivoting the guide all the way back so that the bottom of the ribbon is in front of the printwires, and (2) gently spreading then lifting the guide ears so that the ears are no longer locked in place by the small studs on the nose of the print head.

10. Carefully lift the shifter guide up and away from the print head.
11. Pull the cassette out of the mounting clips on the front frame.
12. Pass the cassette over each of the corner guides—left guide first, right guide last—to lift the used ribbon up and away from the guides.
13. Discard the used cassette and shifter guide.
14. Remove the used corner guides—squeeze the top of the guides and lift the guides from the guide posts. Discard used guides.

INSTALL THE NEW CASSETTE

1. Install the new corner guides.
2. Pull the ribbon stop out of the new cassette and put the stop aside.
3. Snap the new cassette into place—tabs on the front and back of the cassette must snap into clips on the front frame.
4. Install the new ribbon shifter guide. Position the guide above the nose of the print head, then press down until the shifter guide locks into place.
5. Route the new ribbon around the right and left (in that order) corner guides. Use the tapered end of the ribbon stop to route the ribbon around the guides.
6. Move the print head to the extreme left.
7. Place the forms lever into the "LOAD" position.
8. Lower the column scale/tear bar.
9. Move the forms lever to "SHEET" or to "FORMS", depending on paper to be loaded.
10. Snap the rear cover shut.
11. Insert the front lip of the top cover under the body cover and close the top cover.

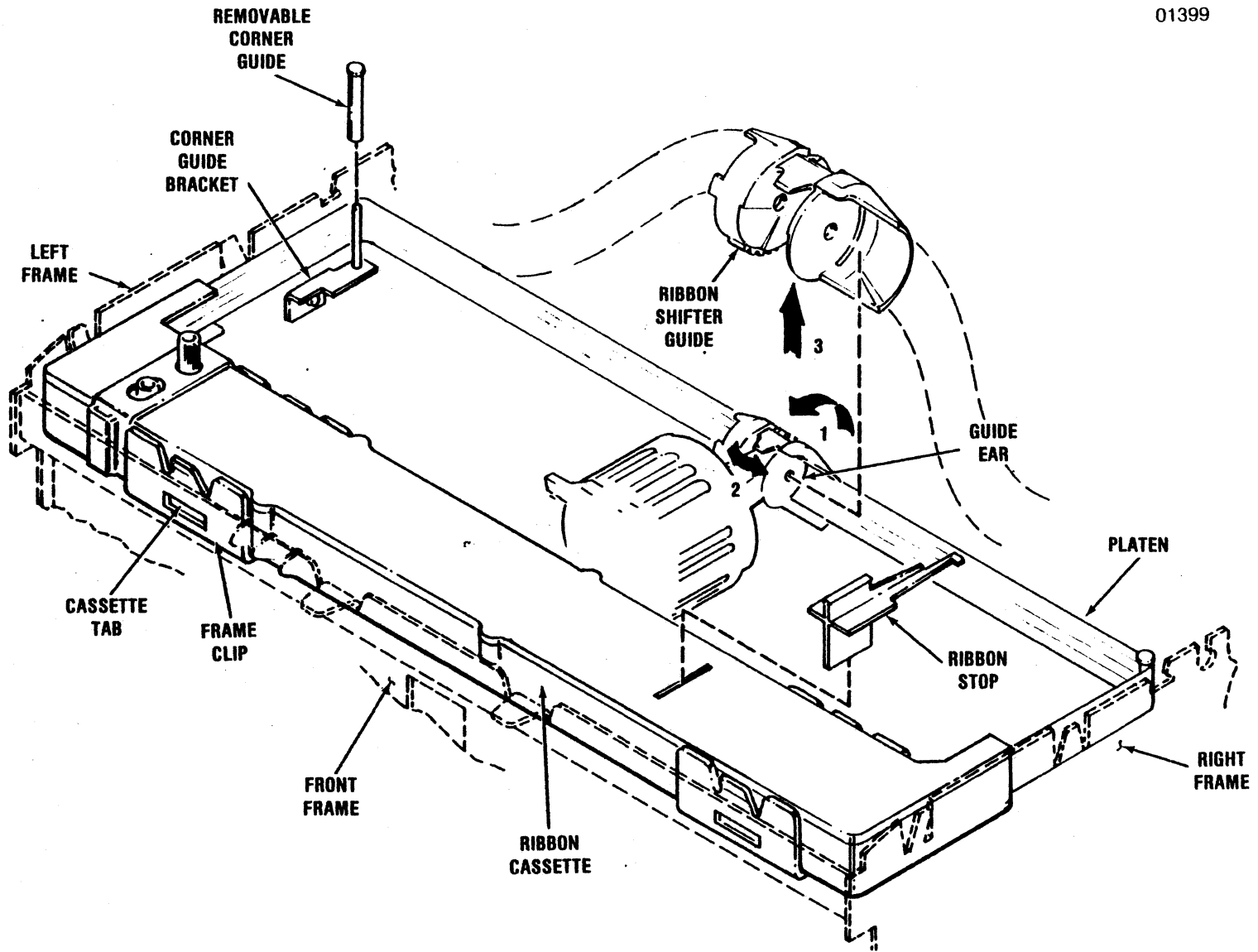

Figure 3-8 Ribbon Cassette Replacement

3.11 PRINT HEAD IMPRESSION ADJUSTMENT

The print head can be adjusted in or out for different form thickness to provide optimum print quality. To adjust the print head impression, perform the following steps:

NOTE

The optional sheet feeder must be tilted back or removed to perform the print head adjustment.

1. Ensure paper is loaded and the forms lever is in the "FORMS" or "SHEET" position.
2. While manually moving the print head from side to side move the head adjustment lever in or out until the smudging occurs or paper rippling occurs, then, move the head adjustment lever back one position.
3. Perform a self-test operation by pressing the **OVRD TEST** switch while the printer is deselected.
4. Check the printout to ensure good clean print quality. If the print is too dark or too light adjust the print head in or out as required.

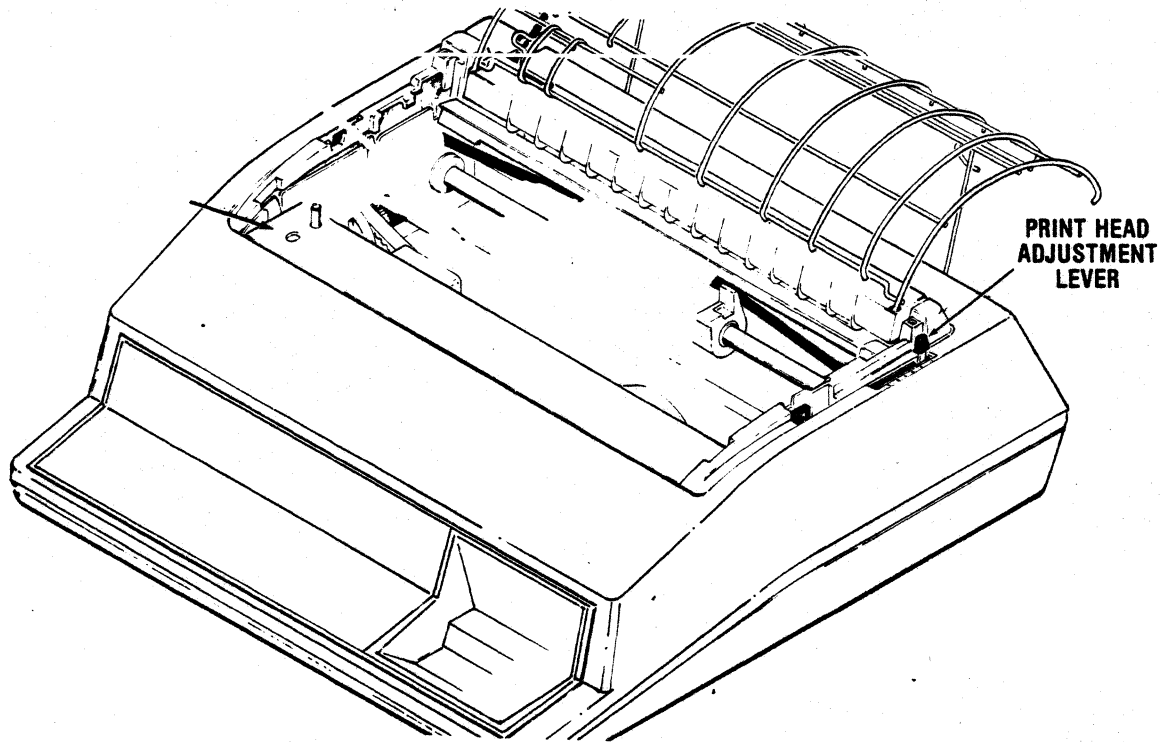

Figure 3-9 Print Head Impression Adjustment

SECTION 4

PRINTER OPERATION

4.1 OPERATING NOTES

Observe the following precautions before operating the printer:

- Always plug the printer into a 3-wire grounded outlet.
- Ensure the data cable connecting host device and printer is in place.
- Ensure all printer covers are closed and secure.
- Never lean or place objects on any part of the printer.

4.2 OPERATING THE PRINTER

The following paragraphs detail operating procedures used when the printer is, (1) powered up, (2) in off-line operating mode, (3) in selected mode, or (4) powered down.

NOTE

Section 2 details feature/configuration mode operating procedures.

POWER UP—To power up the printer:

- Place the **POWER** switch in the **ON** position.

All seven control panel indicators go on, and the printer automatically conducts an internal self-test (par. 4.5). If no errors are detected, six indicators go off, leaving only the **POWER** indicator on. The printer is then in off-line mode (under power and ready to operate).

OFF-LINE MODE—The following printer functions can be controlled in off-line mode:

1. Printer Selection—Press **ON LINE** to select the printer (i.e. place printer on line).
2. Set Top of Form—Press **SET TOF** to set the current print line as the top of form.
3. Forward/Reverse Paper Motions—Press **PAPER FWD/PAPER REV** to move a loaded form in either direction.
4. Line Feeds—Press **LF** to advance a loaded form one line.

CAUTION

The remaining procedures must be performed under the conditions specified to avoid misfeeds, paper jams, or other paper handling problems.

5. Advance Fanfold To Next TOF—With the feeder feature set “OFF” and fanfold paper loaded, press **FORM FEED** to advance the paper to next top of form.
6. Cut Sheet Mode Selection—With the feeder feature set “OFF” and fanfold forms removed, press **CUT SHEET MODE** to select/deselect printer cut sheet mode.

NOTE

The feeder must be tilted back (or removed) to operate the printer in single cut sheet mode.

7. Cut Sheet Loading—With (1) feeder tilted back/removed, (2) feeder feature set “OFF”, (3) fanfold forms removed, and (4) cut sheet mode selected, press **CUT SHEET INSERT** to load a single cut sheet.
8. Cut Sheet Ejection—With feeder feature set “OFF”, press **FORM FEED**, which ejects any cut sheet form (including a form fed from the feeder) from the printer.
9. Feeder Cut Sheet Loading—With a feeder mode selected, and fanfold forms removed, press **FORM FEED**, which:
 - (1) ejects any cut sheet form then in the printer, and
 - (2) loads one form from the selected bin into the printer.
10. Self-Test Function—With fanfold paper loaded and feeder feature set “OFF”, press **OVRD TEST** for the self-test printout.
11. Feature Mode Selection—Press **MODE** to place the printer in feature mode.

Any of the following actions place the printer in off-line mode:

- Setting the power switch "ON" during power up.
- Pressing **ON LINE** while the printer is selected.
- Sending the deselect control code (DC3) while the printer is selected.
- Pressing **ON LINE** while the printer is in either feature or configuration mode.

SELECTED MODE—The printer performs the following functions when selected:

- Receives and prints data sent from the host device.
- Advances fanfold forms/loads and ejects feeder cut sheet forms after receiving appropriate control codes/escape sequences from the host device.
- Loads the electronic Vertical Format Unit (VFU) memory after receiving VFU downstream loading commands from the input device.
- Loads the downstream loaded character set after receiving the appropriate escape sequences.

The printer can be selected by:

- Pressing **ON LINE** while the printer is in off-line mode.
- Receiving the select (DC1) code from the host device.

NOTE

Subsequent printing/paper motion functions are governed by feeder feature selection ("OFF", "SF1", "SF2", or "SF3").

POWER DOWN—To power down the printer:

1. Deselect the printer.
2. Place the **POWER** switch in the "OFF" position.

4.3 OVERRIDE SELF-TEST PRINTOUT

The operator may set the printer to perform an override self-test. During override self-test the printer (1) checks the video signals that are used to print characters, and (2) generates a self-test printout of primary set characters and some of the selected features and configurations.

Printout character density and line spacing depends on the active cpi and lpi settings. The printer **cannot** be set to print a multipass version of the self-test printout.

Figure 4-1 shows a sample self-test printout. The mnemonics used to identify the selected features and configurations are explained below the sample.

The printout can be used to evaluate head motion, paper motion, and print quality. If any of the three need attention, refer to Section 5 for troubleshooting suggestions.

To initiate the override self-test:

1. Load the printer with paper. Use 15" fanfold paper; lines printed during self-test are approximately 13" long.
2. Place the forms lever in the **FORMS** position.
3. Power up the printer.
4. Ensure feeder feature is set "OFF."
5. Press the **OVRD TEST** switch.

The override self-test will begin and video signals will be checked. If the signals are improper, the test will stop and error code 11E or 12E will display. Refer to paragraph 4.4 for further information.

Assuming no errors, the test will conclude with a printing of the self-test printout.

```

ca"=55A"60è A0088000i131406A#09 1*!$%&'()*+,-./0123456789:;<=>?@ABCDEFGHIJKLMN0PQRSTUVWXYZ[\]^_`abcdefg h i j k l m n o p q r s t u v w x y z { | } ~ ¢
0E 1*!$%&'()*+,-./0123456789:;<=>?@ABCDEFGHIJKLMN0PQRSTUVWXYZ[\]^_`abcdefg h i j k l m n o p q r s t u v w x y z { | } ~ ¢

ALF FORM TOP BOT BAUD CTY
0 066 001 066 9600 USA

STB B8P B8C PPM BST PST PAR NDB RC PSL PDL PAG ANSI
0 0 1 2 X X - 7 1 0 0 1 0
    
```

Figure 4-1 Self-Test Printout Sample

(samples shown at approximately 70% actual size)

Mnemonic information appearing in the example above is defined and interpreted as follows:

PRINTED MNEMONIC	MNEMONIC DEFINITION (FEATURE/CONFIGURATION)	MEANING OF CODE PRINTED UNDER MNEMONIC IN EXAMPLE*
ALF	Automatic Line Feed	Feature is disabled (0)
FORM	Form Length	Form length is 66 lines (066)
TOP	Top Margin	Top vertical margin at line 1 (001)
BOT	Bottom Margin	Bottom vertical margin at line 66 (066)
BAUD	Baud Rate	Data transmitted at 9600 Baud
CTY	Country Set	USA character set selected (USA)
STB	Data Strobe	Configuration is normal (0)
B8P	Bit 8 Polarity	Configuration is normal (0)
B8C	Bit 8 Control	Configuration is normal (1)
PPM	Printer on Paper Motion	Configuration is print without CR (2)
BST	Buffer Status	Configuration is for X on/X off (X)
PST	Printer Status	Configuration is for X on/X off (X)
PAR	Parity	Configuration is for none (-)
NDB	Number of Data Bits	Configuration is 7 data bits (7)
RC	Reverse Channel	Configuration is active high (1)
PSL	Prime on Select	Configuration is disabled (0)
PDL	Prime on Delete	Configuration is disabled (0)
PAG	Page Mode	Configuration is enabled (1)
ANSI	Control Code Selection	Configuration is for 703 (0)

*The codes printed under most of the mnemonics correspond to the LCD codes described in Section 2. However, in self-test printouts the:

- (1) Parity (PAR) code will not be printed as a 0, 1 or 3; instead, an O will be printed for odd parity, an E for even, or a - (dash) for none.
- (2) The Buffer Status (BST) and Printer Status (PST) codes will not be printed as 0, 1, 2 or 3. Instead, a 0 will be printed for none, an X for X on/X off, a D for DTR, or an R for Reverse Channel.

4.4 ERROR CODES

The printer performs self-diagnostic operations at the following times:

- At power up.
- During override self-test
- When the operator presses the mechanism control switches.
- When the printer is placed on-line (selected).
- While the printer is on-line.

If an error is detected during a self-diagnostic operation, normal printer operation stops, the alarm sounds, and an error code displays on the LCD.

Errors fall into two broad categories—fatal and recoverable. Fatal errors suggest component failures and a problem requiring trained service personnel. Recoverable errors can usually be cleared by the operator/programmer. A more detailed explanation of the errors/error code displays follows.

FATAL ERRORS; CODES 0E-10E, 21E—The printer automatically conducts an internal self-test at each power up. A number of memory devices are examined during the self-test. If a device fails the

test, the printer displays one of eleven “fatal” error codes (0E-10E, excepting 9E, and 21E).

If a fatal error code displays, power down the printer. Power up again, keeping the OVRD TEST switch depressed; this places the factory set selections into working memory and may clear certain errors.

If the error code displays again, power down the printer and contact the nearest Centronics Service Center. Center information is listed on the last page of this manual.

Error code 9E displays if the downstream loaded character set cannot be printed. 9E may indicate a bad component (fatal error), or may indicate improper loading (recoverable error). If 9E displays, try reloading the character set.

RECOVERABLE ERRORS; CODES 11E-25—Most self-diagnostic operations performed after the internal self-test check for faults that can be corrected by the operator or programmer.

Table 4-1 lists the recoverable error codes, explains the meaning of each code, and provides suggestions for clearing each error.

Table 4-1 Error Codes (Recoverable)

ERROR CODE	MEANING	POSSIBLE CAUSES	REMEDIES
11E*	Bad video count.	<ol style="list-style-type: none"> 1. Forms lever in "LOAD" position. 2. Dirty guide bar. 3. Incorrect print head adjustment. 	<ol style="list-style-type: none"> 1. Move lever to "FORMS/SHEET" position. 2. Clean bar. 3. Loosen adjustment.
12E*	No video signals detected.	<ol style="list-style-type: none"> 1. Head jammed. 	<ol style="list-style-type: none"> 1. Remove obstacle.
13E	Improper pin-fire.	<ol style="list-style-type: none"> 1. Defective printhead. 	<ol style="list-style-type: none"> 1. Replace head.
14E	Bad VFU load.	<ol style="list-style-type: none"> 1. VFU commanded to skip to a channel not loaded in VFU. 2. Printer selected for 703 and on-line with a host requiring ANSI. 	<ol style="list-style-type: none"> 1. Reload VFU. 2. Reselect to ANSI.
9E*/15E	Bad character set load.	<ol style="list-style-type: none"> 1. Attempt to load more than 191 characters. 2. Control character embedded in data. 3. Characters requiring consecutive pinfires sent. 	<ol style="list-style-type: none"> 1. Reload characters (Section 11). 2. Reprogram (Section 11). 3. Reprogram (Section 11).
16E	A reverse paper motion before print was stopped.	<ol style="list-style-type: none"> 1. Printer top cover was opened before power up. 	<ol style="list-style-type: none"> 1. Power up with cover closed.
17E	A forward paper motion before print was stopped.	<ol style="list-style-type: none"> 2. Paper misfeed. 	<ol style="list-style-type: none"> 2. Reload paper.
18E	A print command was ignored.	<ol style="list-style-type: none"> 3. Head jam. 	<ol style="list-style-type: none"> 3. Remove obstacle.
19E	A reverse paper motion after print was stopped.	<ol style="list-style-type: none"> 4. Forms lever left in "LOAD" position. 	<ol style="list-style-type: none"> 4. Place lever in "FORMS/CUTSHEET".
20E	A forward paper motion after print was stopped.	<ol style="list-style-type: none"> 5. Bad data. 	<ol style="list-style-type: none"> 5. Reprogram.
		<ol style="list-style-type: none"> 6. Inappropriate feature/configuration selection(s). 	<ol style="list-style-type: none"> 6. Reselect.
24E/25E	Printer idled.	<ol style="list-style-type: none"> 1. Top cover open or off. 2. Attempting new operations while an error code is displayed. 	<ol style="list-style-type: none"> 1. Close cover. 2. Clear original error.

* sometimes fatal

SECTION 5

PRINTER MAINTENANCE

5.1 PREVENTIVE MAINTENANCE

Although there are no required preventive maintenance procedures, it is advisable to periodically inspect and clean the printer area immediately accessible under the top cover.

During paper loading or ribbon replacement, the printer should be inspected for a build up of dried

ink, lint, or foreign material. If a build up of material is evident, clean the area with a light bristle brush or lint free cloth.

Table 5-1 below lists the maintenance required on certain areas of the printer. The maintenance may be required more or less frequently depending on the printer application and operating environment.

Table 5-1 Preventive Maintenance

ASSEMBLY	FREQUENCY	MAINTENANCE
Covers	As Required	Clean all the cover assemblies using a mild detergent and a lint-free cloth.
Internal Inspection	Each Ribbon Change	Remove the top cover and visually inspect interior of printer for loose wires, connectors, and hardware, chafing of cables, and worn or damaged parts.
Print Head Assembly	Each Ribbon Change	Using a lint-free cloth gently remove all dried ink from the front of the print head.
Print Head and Carriage	Each Ribbon Change	After removing ribbon, use a light-bristle brush to carefully remove the dust and residue from the print head and carriage assembly.
Platen Assembly	As Required	Clean platen assembly using a mild detergent.

5.2 TROUBLESHOOTING GUIDE

The troubleshooting guide, Table 5-2, lists some malfunctions which may occur, the probable causes, and the remedies. If the printer remains inoperative after performing the remedies in-

dicated, the printer should be serviced by qualified service personnel.

NOTE

Paragraphs 4.3 and 4.4 provide additional troubleshooting suggestions.

Table 5-2 Troubleshooting Guide

TROUBLE	PROBABLE CAUSE	REMEDY
Print too light.	Print head adjustment lever improperly adjusted. Worn or defective ribbon.	Adjust head adjustment lever to desired print quality. Replace ribbon cassette.
Cut sheet form does not advance.	Not in cut sheet mode. Forms lever not in "CUT SHEET" position.	Press CUT SHEET MODE switch on the operators control panel. Move forms lever to the "CUT SHEET" position.
Ribbon does not feed properly.	Ribbon twisted or improperly loaded.	Check ribbon cassette replacement procedures.
Printer completely inoperative.	AC input plug not connected. AC input fuse blown.	Connect AC input plug to power source. Check if POWER indicator is lit. If indicator is not lit, replace AC input fuse.
Power On/Data Sent-printer does not print.	Input cable not connected. Printer not selected.	Check that connectors at both ends of data input cable are properly connected to mating connectors. Press ON LINE switch on the control panel.

SECTION 6

REMOVAL/REPLACEMENT

6.1 GENERAL

This section details removal/replacement procedures. The covers, print head assembly, and input fuse are all operator replaceable. For detailed removal/replacement procedures of all recommended spare parts refer to the Model 358-3,-4 Technical Manual.

NOTE

Ensure the power cord is removed from the power outlet before performing any removal/replacement procedures.

6.2 REMOVAL COVER ASSEMBLIES

The following procedures detail the removal of the top, rear, and body covers. To remove the covers, refer to Figure 6-1 and perform the following:

NOTE

The optional sheet feeder must be tilted back/removed before printer covers can be removed.

NOTE

The clear portion of the top cover houses a magnet that enables/disables an interlock switch mounted on the left frame. Removing the top cover enables the interlock and stops the printer.

TOP COVER

1. Remove the top cover by lifting the rear edge of the cover up and off the printer.

REAR COVER

1. Unsnap the top portion of the rear cover from the body cover.
2. Lift the rear cover up and off the printer.

BODY COVER

1. Remove the top and rear covers from the printer.
2. Remove the two Phillips head screws at the rear of printer mounting the body cover to the printer base.
3. Loosen the thumb screw mounting the front of the body cover to the printer base.
4. Lift the body cover up and off the printer.

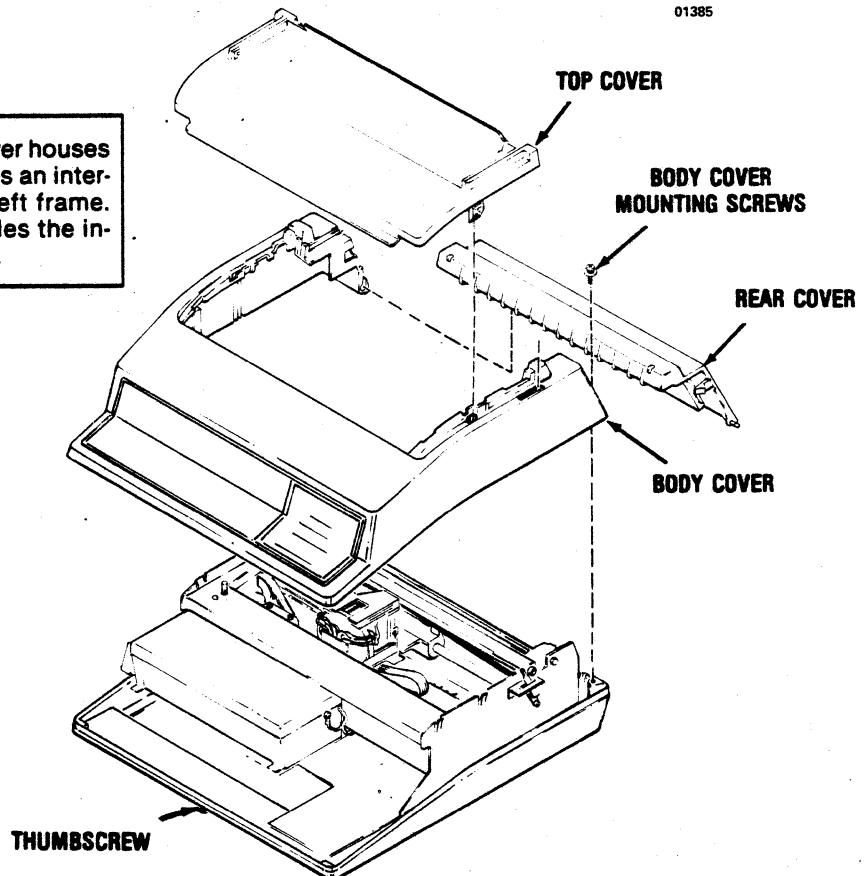

Figure 6-1 Removal Cover Assemblies

6.3 REMOVAL/REPLACEMENT PRINT HEAD ASSEMBLY

To remove and replace the print head assembly, refer to Figures 6-2 and 6-3 and perform the following steps:

NOTE

The optional sheet feeder must be tilted back/removed before the print head assembly can be removed.

1. Remove the top cover by lifting the rear edge of the cover up and off the printer.
2. Unsnap the top portion of the rear cover and place in the open position.
3. Move the forms lever to the "LOAD" position.
4. Lift the column scale to the up position.
5. Pull the head adjustment lever towards the front of the printer to its maximum position.
6. Remove the ribbon guide from the front of the print head per paragraph 3.10.
7. Disconnect the ribbon stepper motor connector (see Figure 6-3).
8. Disengage latches at the top and bottom of the head flex cable headers (Figure 6-3).
9. Disconnect the print head flex cables.
10. While pulling the print head towards the front of the printer, lift the head up and out of the printer.
11. To replace the print head assembly, reverse steps 1 through 10.
12. Ensure the black, numbered cam located on the front of the print head is in position "A" following replacement of the print head.

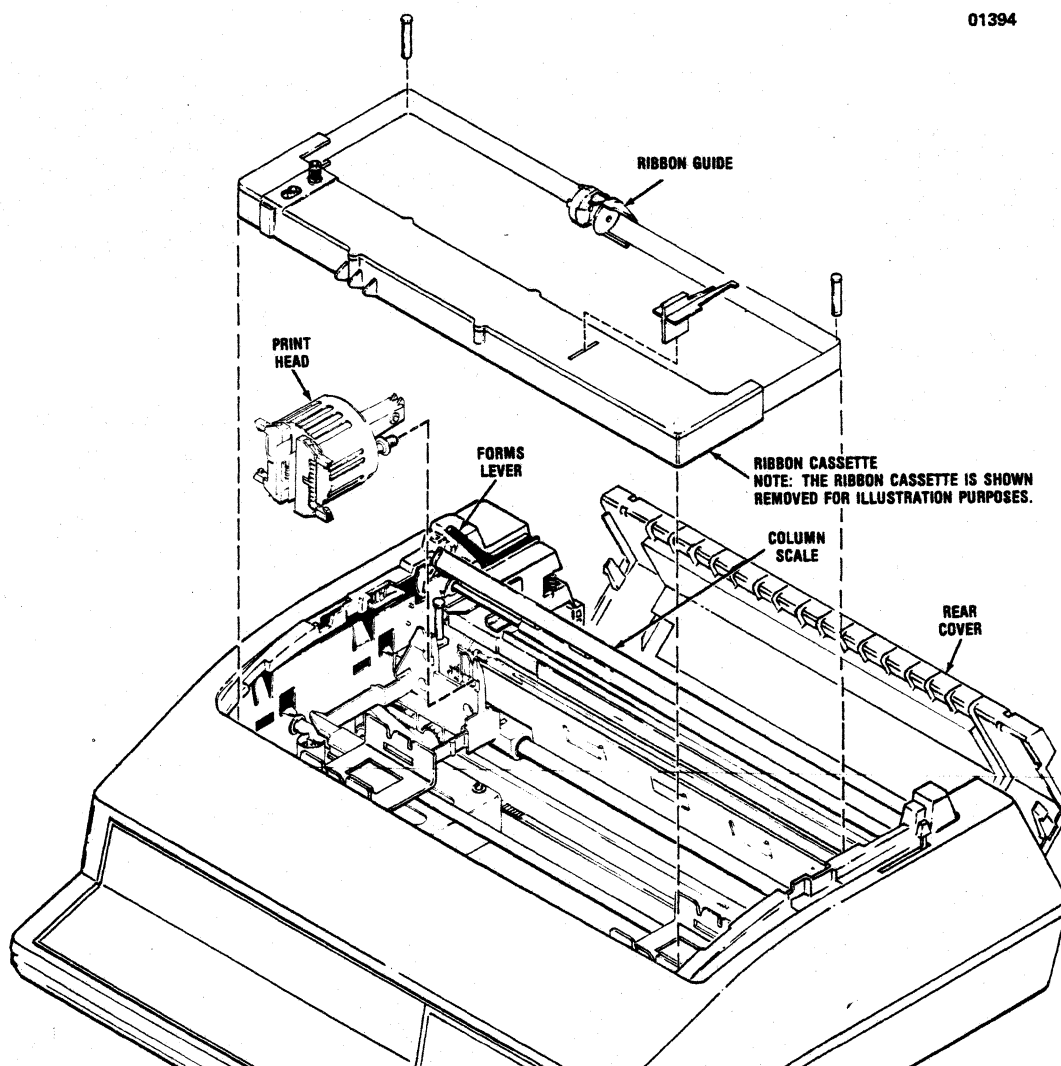

Figure 6-2 Removal Print Head Assembly

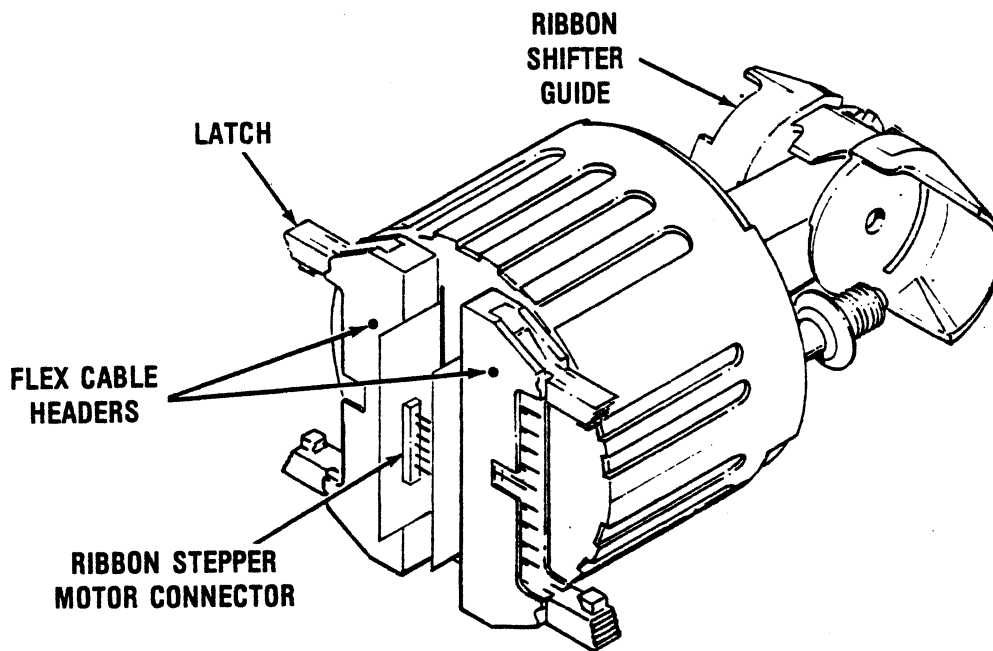

Figure 6-3 Print Head Assembly

6.4 REMOVAL/REPLACEMENT INPUT FUSE

To remove and replace the input fuse, refer to Figure 6-4 and perform the following steps:

1. Locate the input fuse at the left rear of the printer.
2. Using a flat blade screwdriver rotate the fuse holder counterclockwise until loose, then remove the fuse holder and defective fuse.
3. Install new fuse and fuse holder.

01387

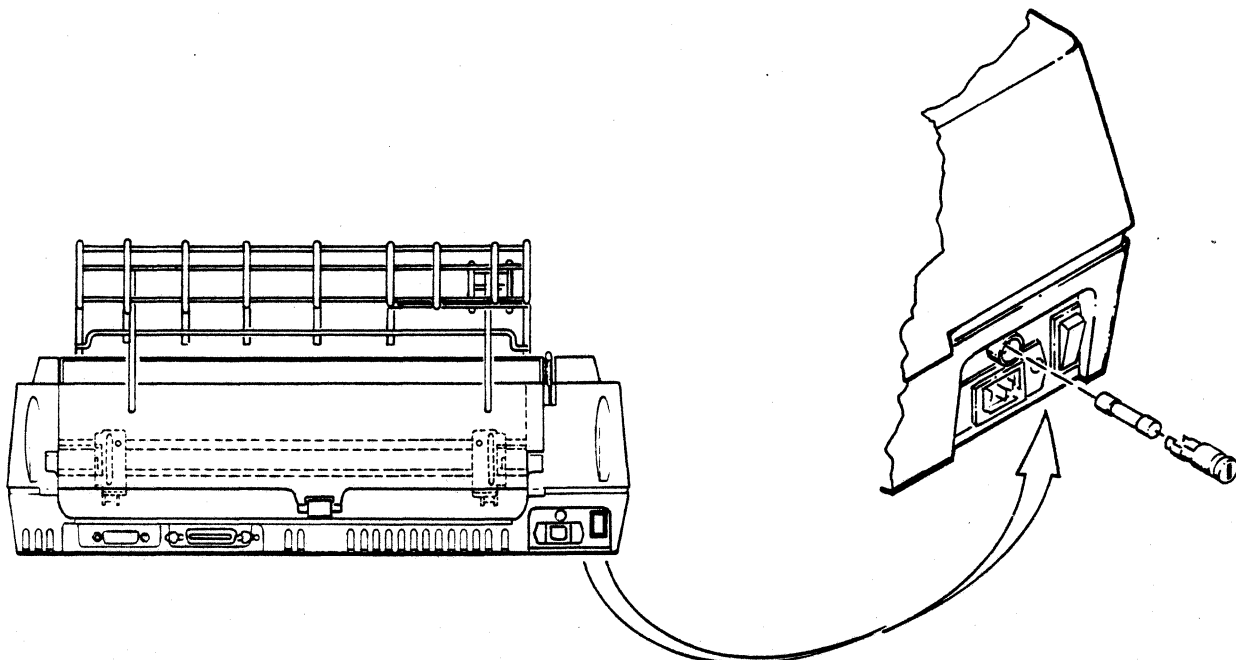

Figure 6-4 Removal Input Fuse

SECTION 7 INSTALLATION

7.1 GENERAL

This section contains information on installing and setting-up the printer. The printer should be installed in an area that is free from excessive dust and dirt and is easily accessible from all sides.

7.2 PRINTER INSPECTION

After unpacking, visually inspect the printer for signs of damage received during shipment. Immediately notify the common carrier of any damage.

7.3 SITE CONSIDERATIONS

When selecting a site to install the printer the following information should be taken into consideration.

PRINTER DIMENSIONS—Refer to Figure 7-1.

PRINTER INSTALLATION SPECIFICATIONS —

Refer to the following printer specifications before installing the printer.

WEIGHT

Printer: 50 lbs (23 kg)

Stand: 22.5 lbs (10 kg)

HUMIDITY

Operating: 10% to 90% (Non-Condensing)

Storage: 10% to 95% (Non-Condensing)

TEMPERATURE

Operating: 50° to 104°F (10° to 40°C)

Storage: -40° to 151°F (-40° to 66°C)

ELECTRICAL

115 VAC +10%, -15%; 60 Hz ±1 Hz

230 VAC +10%, -15%; 50 Hz ±1 Hz

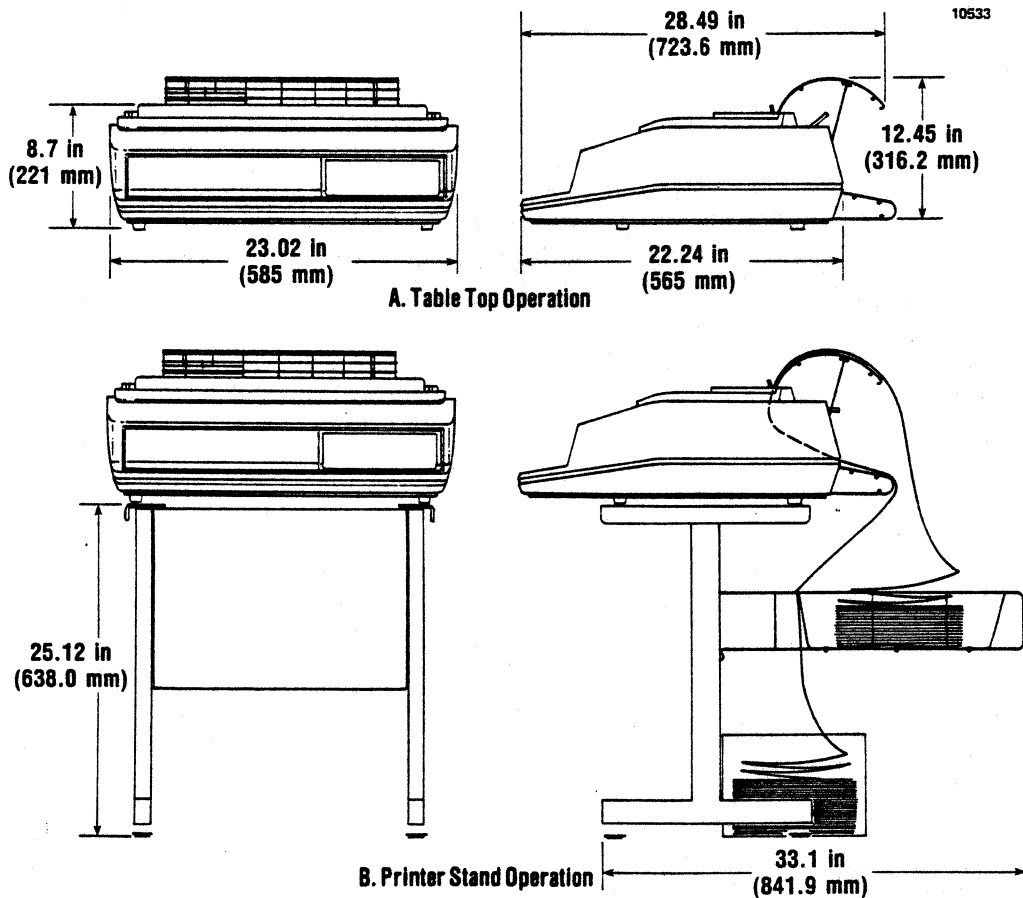

Figure 7-1 Printer Dimensions

7.4 PRINTER SET-UP

The following procedures detail the set-up of the printer prior to operation at the installation site. Refer to Figure 7-2 and 7-3 and perform the following steps.

NOTE

Refer to Figure 7-2 and 7-3 for steps 1 through 6.

1. Locate the paper rack inlet and facing the rear of the printer install the rack into the two mounting holes on the left and right frames.
2. Locate the paper rack outlet assembly and remove the two nylon thumbnuts from the two mounting arms. Retain the thumbnuts.
3. Facing the rear of the printer, install the two end mounting tabs on the paper rack outlet assembly into the two mounting holes on top of the rear cover.
4. Install the two threaded mounting arms of the paper rack outlet assembly into the mounting holes in the middle of the rear cover.
5. Open the rear cover and install the two nylon thumbnuts onto the threaded portion of the mounting arms.
6. Close the rear cover.
7. Locate the ribbon cassette and install per paragraph 3.8.
8. Ensure the power switch is **OFF** and plug the printer into the appropriate power outlet.

NOTE

Always use a 3-wire grounded outlet.

9. Using the appropriate shielded data cable* (parallel or serial input) connect the printer to the input device.

*Ensure printer/host connectors are compatible; an adapter may be required.

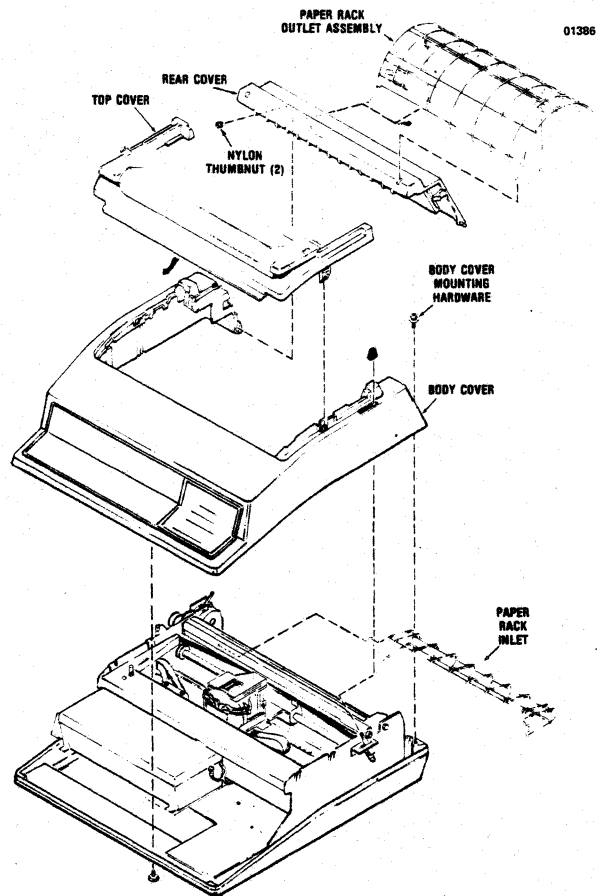

NOTE: COVERS ARE SHOWN REMOVED FOR ILLUSTRATION PURPOSES.

Figure 7-2 Installation Paper Outlet Rack, Paper Inlet Rack

NOTE

The data cable should be terminated to chassis ground at either the printer connection or host connection. Figure 7-3 shows the recommended terminating connection on the printer.

10. Install the form (fanfold or cut sheet) to be printed as described in Section 3.
11. Verify the selection of printer features and configuration as described in Section 2.
12. Set the power switch to the **ON** position and perform a self-test operation by pressing the **OVRD TEST** switch on the control panel.
13. Press the **ON LINE** switch to enable the printer to receive data.

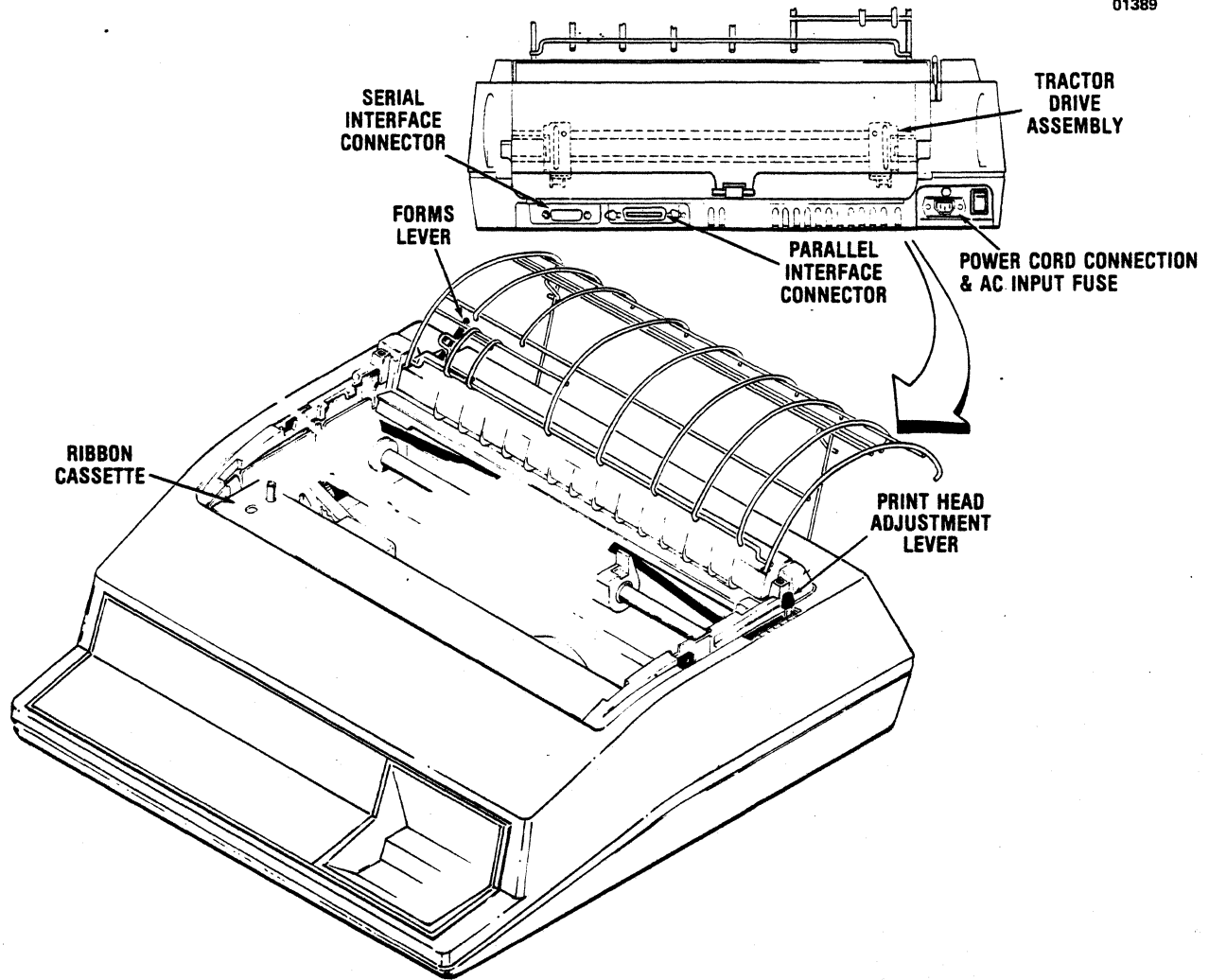

Figure 7-3 Printer Set-Up

SECTION 8

INTERFACE INFORMATION

8.1 GENERAL

The printer is connected to the input device, via the input data cable, for either parallel or serial data input. In the right rear of the printer a parallel interface connection is provided via an Amphenol 57 series 36-pin connector and a serial interface connection via an EIA-RS232C, 25 pin connector. Four unused pins in the serial interface connector are used for the optional current loop connection. The following paragraphs describe the parallel and serial interfaces in detail.

8.2 PARALLEL INTERFACE CONNECTION

The pin-outs of the 36-pin parallel interface connector are listed in Table 8-1. A description of the external and printer generated parallel signals follow the table.

EXTERNAL GENERATED SIGNAL DESCRIPTION—

The following signals are generated by the input device.

DATA STROBE—Data strobe is a negative going pulse used to transfer the incoming parallel data into the printer logic. The pulse duration of the signal must be a minimum of 1.0 microsecond. The leading and trailing edges of data strobe and the input data must be shown in Figure 8-1.

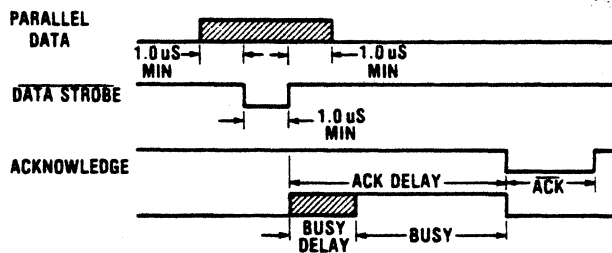

Figure 8-1 Parallel Interface Timing Diagram

Table 8-1 Parallel Interface Connector Pin-Outs

PIN	SIGNAL	PIN	SIGNAL
1	DATA STROBE	19	Twisted Pair Ground
2	Data Bit 1	20	Twisted Pair Ground
3	Data Bit 2	21	Twisted Pair Ground
4	Data Bit 3	22	Twisted Pair Ground
5	Data Bit 4	23	Twisted Pair Ground
6	Data Bit 5	24	Twisted Pair Ground
7	Data Bit 6	25	Twisted Pair Ground
8	Data Bit 7	26	Twisted Pair Ground
9	Data Bit 8	27	Twisted Pair Ground
10	ACKNOWLEDGE	28	Twisted Pair Ground
11	BUSY	29	Twisted Pair Ground
12	PAPER OUT	30	INPUT PRIME RETURN
13	SELECT	31	INPUT PRIME
14	GROUND	32	FAULT
15	Not Used	33	GROUND
16	GROUND	34	Not Used
17	CHASSIS GROUND	35	Not Used
18	+5V	36	Not Used

DATA BITS 1-8—Data bits 1 through 8 contain the ASCII character and control code information. The logic level of each data line must be settled at least 1.0 microsecond before the leading edge of the data strobe pulse and remain at its logic level until at least 1.0 microsecond after the trailing edge of the data strobe pulse.

INPUT PRIME—Input prime is an active low signal which causes the print head to return to the left margin and resets the printer logic on the trailing edge of the signal.

NOTE

Data should not be sent during an Input Prime as Centronics reserves this sequence for factory testing.

PRINTER GENERATED SIGNAL DESCRIPTION—The following signals are generated by the printer.

ACKNOWLEDGE—Acknowledge is an active low signal used to verify the transfer of incoming data from the input device to printer logic or to signify the end of a functional operation. Once a code is sent to the printer, an acknowledge pulse must be received before a new code can be sent.

BUSY—Busy is an active high signal which inhibits data transmission from the input device. Busy goes active on the trailing edge of data strobe or when either the paper empty or fault status line is active high.

PAPER EMPTY—Paper empty is a positive-going signal that indicates the printer is out of paper.

SELECT—An active high select signal indicates either the **ON LINE** switch has been pressed or a **SELECT** code has been received and that the printer is in a ready condition.

8.3 SERIAL INTERFACE CONNECTION

The pin-outs of the 25-pin serial interface connector are listed in Table 8-2. A description of the data set and printer generated signals follow the table.

DATA SET GENERATED SIGNAL DESCRIPTION—The following signals are generated by the data set.

NOTE

A + V or Space condition indicates a voltage greater than +3 volts. A - V or Mark condition indicates a voltage less than -3 volts.

Signals **CLEAR TO SEND**, **DATA SET READY** and **CARRIER DETECT** will be interpreted as a logical 1 if they are not connected to the data set.

Table 8-2 Serial Interface Connector Pin-Outs

PIN	EIA SIGNAL NAME	SIGNAL
1	AA	Protective Ground
2	BA	Transmitted Data
3	BB	Received Data
4	CA	Request to Send
5	CB	Clear to Send
6	CC	Data Set Ready
7	AB	Signal Ground
8	CF	Carrier Detect
11	SBA	Reverse Channel
20	CD	Data Terminal Ready
12	---	Host Receive Current Loop +
13	---	Host Receive Current Loop -
14	---	Printer Transmit Status +
15	---	Printer Transmit Status -

RECEIVED DATA—Data source to the printer.

CLEAR TO SEND—A + V will enable X-ON/X-OFF to be transmitted. A - V will disable the transmitter.

DATA SET READY—A + V will allow transmitted data to be accepted by the printer. A - V will not allow data to be accepted.

CARRIER DETECT—A + V will allow transmitted data to be accepted by the printer. A - V will not allow data to be accepted.

PRINTER GENERATED SIGNAL DESCRIPTION—The following signals are generated by the printer.

TRANSMITTED DATA—Used to indicate the buffer status when in the X-ON/X-OFF mode.

REQUEST TO SEND—This line is + V when in the X-ON/X-OFF mode.

REVERSE CHANNEL—Used for transmitting the printer/buffer status when in the reverse channel mode. The line is normally in a - V condition. When the buffer is full, this line goes to a + V condition until the printer is able to receive data again. The line is held at buffer empty polarity (- V) when in the X-ON/X-OFF or Data Terminal Ready.

DATA TERMINAL READY—This line is held at + V when selected and not used for the status report line.

9.1 Model 358 -3,-4 SPECIFICATIONS (cont.)

PAPER HANDLING

Vertical Pitch	Programmable for 3, 4, 6, 8, and 12 lines per inch
Single Line Feed Time	50 msec. (maximum)
Vertical Slew Speed	8 inches per second.
Forms Length	1 to 192 lines.
Paper Movement	Forward and reverse (1 inch max. fanfold mode) Fanfold: 120 steps per inch (.00833 in/step) Cut Sheet: 108 steps per inch (.00926 in/step)

PAPER REQUIREMENTS

Fanfold Forms

Width	3.0 in. (76 mm) to 15.0 in. (381 mm).
Copies	Up to six parts.
Maximum Thickness	0.0204 in. (0.52 mm).

Cut Sheet Forms

Width	4.0 in. (101 mm) to 12.0 in. (305 mm).
Copies	Up to six parts.
Maximum Thickness	0.0204 in. (0.52 mm).

NOTE: For detailed paper specifications, refer to paragraph 3.7, Forms Design.

PHYSICAL/ENVIRONMENTAL/ELECTRICAL

Height	8.7 inches (221 mm)
Depth	22.24 inches (565 mm)
Width	23.02 inches (585 mm)
Weight	50 lbs. (23 kg)
Temperature	Operating: 50° to 104°F (10° to 40°C) Storage: -40° to 151°F (-40° to 66°C)
Humidity	Operating: 10% to 90% (Non-Condensing) Storage: 10% to 95% (Non-Condensing)
Power	
Switcher Power Supply	90 VAC to 128 VAC or 180 VAC to 256 VAC 47 to 63 Hz
Input Current	3A RMS maximum for 110 VAC (nominal). 1.5A RMS maximum at 220 VAC (nominal).

SECTION 10

PROGRAMMING INFORMATION

10.1 GENERAL

Host-generated control codes and escape sequences can be sent to control many printer functions.

Control codes are sent to control:

- Select/Deselect
- Line Feed
- Form Feed
- Vertical Tab
- Horizontal Tab
- Carriage Return
- Expanded Print
- Character Set Selection
- Serial Status
- VFU Loading
- VFU Command
- Page Mode Control
- Delete
- Bell (Audio Alarm)

Table 10-1 lists the control codes the printer accepts. Most codes perform the same function when the printer is configured for 703 or ANSI mode. A few codes (e.g. GS or RS) can only be used if 703 mode is configured. Note that SI can only be used if ANSI is configured, and that SO performs one function in 703 and another in ANSI.

Escape sequences are sent to control:

- Feeder Mode Selection
- Horizontal Pitch
- Horizontal Tabs
- Vertical Pitch
- Vertical Tabs
- Vertical Margins
- Form Length
- Country
- Underline
- Subscript/Superscript
- Reverse Line Feed

Escape sequences also control:

- Selection/Deselection of the Primary and Alternate Character Sets (par. 10.4).
- Loading of the Downstream Loaded Character Set (par.11.4).
- Selection/Deselection of Graphics Mode (par. 11.6).
- Color printing (par. 11.7).

10.2 CONTROL CODES

Control codes are sent to the printer along with character codes via the input data lines. These codes are interpreted as instructions by the printer and initiate a specific function. The following paragraphs describe the printer control codes.

703/ANSI MODE CONTROL CODES—The control codes listed at the top of Table 10-1 are accepted and initiate the same function in either the 703 or ANSI mode. Each code is described in detail in the following paragraphs.

Select (DC1)—Receipt of a select code selects the printer independent of the control panel. If PRIME ON SELECT is enabled, the input line buffer is cleared and the print head is moved to the left margin.

Deselect (DC3)—Receipt of a deselect code deselects the printer independent of the control panel and moves the print head to the left margin.

Line Feed (LF)—If the printer is on line, receipt of a LF code causes the action selected in the print on paper motion feature. If “paper motion does not cause print” is selected, the printer immediately advances the paper one line on receipt of a LF code. If “print with or without carriage return” is selected, the printer immediately prints the line followed by the paper advance of one line with or without a carriage return.

Form Feed (FF)—When the printer is in:

- Fanfold mode with fanfold forms loaded, FF advances the paper to the next top of form.
- Fanfold mode with a cut sheet loaded, FF ejects the form.
- Bin 1, 2, or 3 feeder mode, FF (1) ejects the form which is loaded, and (2) loads a form from bin 1, 2, or 3.

Vertical Tab (VT)—If the printer is selected, receipt of a VT code causes the paper to advance to the next sequential vertical tab location.

If no vertical tabs are set, the printer performs a form feed.

Table 10-1 Control Codes, Model 358-3,-4 Printer

MNEMONIC	DECIMAL	OCTAL	HEX	FUNCTION	PRINTER CONFIGURAT'N
DC1	17	021	11	Select command	703 or ANSI
DC3	19	023	13	Deselect command	703 or ANSI
LF	10	012	0A	Advances form one line	703 or ANSI
FF	12	014	0C	Advance fanfold paper to next top of form/load from feeder	703 or ANSI
VT	11	013	0B	Paper motion to next tab location	703 or ANSI
HT	9	011	09	Paper motion to next tab location	703 or ANSI
CR	13	015	0D	Print command	703 or ANSI
DLE ENQ	165	020 005	10 05	Serial status	703 or ANSI
STX	2	002	02	Page mode enabled*	703 or ANSI
ETX	3	003	03	Page mode print command*	703 or ANSI
DEL	127	177	7F	Resets printer logic if printer is selected	703 or ANSI
BEL	7	007	07	Sounds audio alarm	703 or ANSI
SO	14	016	0E	Invokes the designated alternate character set	ANSI**
SI	15	017	0F	Invokes the primary character set	ANSI only
GS	29	035	1D	Start downstream loading	703 only
RS	30	036	1E	Stop downstream loading	703 only
US	31	037	1F	VFU command	703 only
SO	14	016	0E	Expanded print	703**
ESC 3	27 51	033 063	1B 33	Invokes the designated alternate character set	703 only
ESC 4	27 52	033 064	1B 34	Invokes the primary character set	703 only

*Printer must be selected for parallel data

**Note that the function of SO depends on which mode (703 or ANSI) is selected.

The VT code is not acknowledged or processed while the printer is deselected.

Horizontal Tab (HT)—If the printer is selected and horizontal tabs are set, receipt of a HT code causes printing to continue at the next sequential horizontal tab location. If no horizontal tabs are set, or there are no more on the line printed, the HT code is changed to a space. The HT code is not acknowledged or processed while the printer is deselected.

Carriage Return (CR)—If the printer is selected and printable characters have been received, receipt

of a CR code causes immediate printing. Data is accepted by the printer until a CR code or a full buffer of printable characters is received. In either case, the printer automatically prints the received characters. When printing is complete the printer performs an auto line feed, if enabled. If the CR code is the first character in the buffer, the code is acknowledged and ignored. A CR code is not acknowledged while the printer is deselected.

Serial Status (DLE ENQ)—In the serial mode the sequence DLE ENQ requests printer status. The printer responds by sending DLE, status, as defined below.

SERIAL STATUS

BIT	STATE	STATUS
0	High (1)	Paper Out
1	High (1)	Deselected
2	High (1)	Buffer Full
3	High (1)	Parity Error Received since Last Printer Status.

Page Mode Select (STX)—places the printer in page mode. In this mode, the printer can receive up to 4096 characters (including control codes) without going busy.

Page Mode Print Command (ETX)—Causes printing of characters received after the STX command was sent.

DEL—If a DEL code is received while the printer is selected and PRIME ON DELETE is enabled, the input line buffer is cleared and the print head is returned to the left margin.

BEL—Receipt of a BEL code while the printer is selected causes the speaker to generate an audible tone for approximately one second.

ANSI MODE CONTROL CODES—In addition to the codes listed above, SO and SI may be used when ANSI is configured.

SO—When the printer is in ANSI mode, the SO control code invokes the designated alternate character set. For details, refer to paragraph 10.4.

SI—When the printer is in ANSI mode, the SI control code invokes the primary character set. For details, refer to paragraph 10.4.

703 MODE CONTROL CODES—The control codes listed in the lower portion of Table 10-1 can only be used when the printer is selected for 703 mode. The 703 mode codes are detailed below:

VFU Downstream Loading (GS,RS)—The sequence for downstream loading is initiated by sending a "START LOAD" code (GS-octal 035) followed by two bytes per line, and terminated by a "STOP LOAD" code (RS-octal 036).

The data format shown in Figure 10-1 must be used to load the 2 channel electronic vertical format unit.

The channel data for the first line is made up of bytes 1 and 2 after the load code; the second line is made up of bytes 3 and 4 after the start code, etc. See NOTE for Top of Form.

NOTE

Top of Form function requires that channel 1 be set in the first byte after the start load code. Also, the last two bytes prior to the stop load code have channel 1 set to make the downstream loading format simulate paper tape loading. These last two bytes are not recognized as part of the VFU data.

Excess data (data above the maximum memory capacity) causes a fault condition that deselected the printer, illuminates the FAULT indicator and displays an error code in the LCD. All data after a second Top of Form code appearing in the middle of a data stream is ignored until a stop code appears.

Table 10-2 is an example of the data input for an 11-inch form with vertical tabs every six lines.

VFU Command (US)—The VFU command consists of two bytes of sequential data. The two bytes are an octal 037-US followed by either "Skip N Lines" or "Skip to Channel X" determined by bit 4 of the second byte. If bit 4 is a 1, then "Skip N Lines" (15 lines maximum) is selected; if bit 4 is a 0, "Skip to Channel X" is selected. The format for the second byte follows:

If a command is received to skip a channel other than channel 1 or channel 2, the printer generates a fault condition, deselected the printer, illuminates the FAULT indicator and displays an error code in the LCD.

Expanded Print (SO)—Receipt of a SO code causes the current line to be printed in expanded format, only if the current horizontal pitch is 10, 12, 13.2, 15, or 16.5 characters per inch (cpi). The number of elongated characters printable per line shall not exceed one half the print buffer size.

Select Alternate Character Set (ESC 3)—Receipt of an ESC 3 code while the printer is selected, invokes the alternate character set.

Select Primary Character Set (ESC 4)—Receipt of an ESC 4 code while the printer is selected, invokes the primary character set.

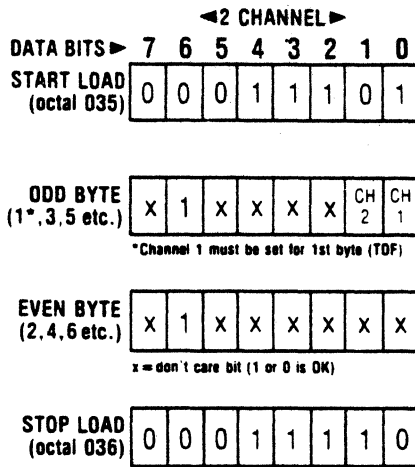

Figure 10-1 VFU Data Input Format

10.3 ESCAPE SEQUENCES

The printer accepts and interprets escape sequences sent to it in either the 703 or ANSI mode. In the escape sequences which follow, the escape character (octal 033) is designated as ESC. The second character in the sequence, if not a terminating character, may be a "[" (octal 133), "(" (octal 050), ")" (octal 051), or "%" (octal 045) depending on the function of the sequence. Numeric parameters are designated as n , n_1 , n_2 ... etc. The graphic characters in the escape sequences shown are from the US ASCII character set illustrated in Figure 10-2.

A numeric parameter is a sequence of ASCII decimal digits (octal 060 through 071). The parameter is interpreted as an unsigned decimal integer, with the most significant digit transmitted first. Leading zeros are allowed, but not necessary. Skipped or unspecified parameters have a value of zero; extra parameters are ignored. Invalid terminators cause the sequence to be ignored. Up to 16 parameters may be inputted with a ";" (octal 073) between each.

NOTE

Escape sequences must not be sent during an INPUT PRIME. Centronics reserves this sequence for in-house testing.

A description of most of the Model 358-3,-4 escape sequences follows.

NOTE

Paragraphs 10.4, 11.4, and 11.6 also describe escape sequences.

SET FEEDER MODE—The printer can be operated in four modes:

- Fanfold/single cut sheet mode.
- Bin 1 feeder mode.
- Bin 2 feeder mode.
- Bin 3 feeder mode.

The following escape sequences are used to select operating mode:

ESCAPE SEQUENCE	FUNCTION / COMMENT
ESC [0 {	Selects fanfold/single cut sheet mode.
ESC [1 {	Selects bin 1 feeder mode.
ESC [2 {	Selects bin 2 feeder mode.
ESC [3 {	Selects bin 3 feeder mode.

Each escape sequence configures the printer to move paper/print forms according to parameters set for the mode (refer to Section 2).

Particular uses of the feeder escape sequences are described below:

PAPER MOTION—To eject a printed form and reload from the same bin, send:

FF

To eject a printed form and load from a different bin, send:

ESCAPE SEQUENCE	FUNCTION / COMMENT
ESC [1 { and FF	(load bin 1)
ESC [2 { and FF	(load bin 2)
ESC [3 { and FF	(load bin 3)

To eject a printed form WITHOUT reloading from a bin, send:

ESC [0 { and FF

PRINTING—Sending the feeder escape sequences ahead of a print command configures the printer for one of the four selectable sets of print parameters; send:

ESC [0 {	to select fanfold/single cut sheet mode parameters.
ESC [1 {	to select bin 1, bin 2, or 3 mode parameters.
ESC [2 {	
ESC [3 {	

CHARACTER	SPACE	!	"	#	\$	%	&	Acute
OCTAL CODE	040	041	042	043	044	045	046	047
DECIMAL CODE	032	033	034	035	036	037	038	039
HEX CODE	020	021	022	023	024	025	026	027
CHARACTER	()	*	+	comma	hyphen	period	slash
OCTAL CODE	050	051	052	053	054	055	056	057
DECIMAL CODE	040	041	042	043	044	045	046	047
HEX CODE	028	029	02A	02B	02C	02D	02E	02F
CHARACTER	0	1	2	3	4	5	6	7
OCTAL CODE	060	061	062	063	064	065	066	067
DECIMAL CODE	048	049	050	051	052	053	054	055
HEX CODE	030	031	032	033	034	035	036	037
CHARACTER	8	9	:	;	<	=	>	?
OCTAL CODE	070	071	072	073	074	075	076	077
DECIMAL CODE	056	057	058	059	060	061	062	063
HEX CODE	038	039	03A	03B	03C	03D	03E	03F
CHARACTER	@	A	B	C	D	E	F	G
OCTAL CODE	100	101	102	103	104	105	106	107
DECIMAL CODE	064	065	066	067	068	069	070	071
HEX CODE	040	041	042	043	044	045	046	047
CHARACTER	H	I	J	K	L	M	N	O
OCTAL CODE	110	111	112	113	114	115	116	117
DECIMAL CODE	072	073	074	075	076	077	078	079
HEX CODE	048	049	04A	04B	04C	04D	04E	04F
CHARACTER	P	Q	R	S	T	U	V	W
OCTAL CODE	120	121	122	123	124	125	126	127
DECIMAL CODE	080	081	082	083	084	085	086	087
HEX CODE	050	051	052	053	054	055	056	057
CHARACTER	X	Y	Z	[\]	^	Underline
OCTAL CODE	130	131	132	133	134	135	136	137
DECIMAL CODE	088	089	090	091	092	093	094	095
HEX CODE	058	059	05A	05B	05C	05D	05E	05F
CHARACTER	Grave	a	b	c	d	e	f	g
OCTAL CODE	140	141	142	143	144	145	146	147
DECIMAL CODE	096	097	098	099	100	101	102	103
HEX CODE	060	061	062	063	064	065	066	067
CHARACTER	h	i	j	k	l	m	n	o
OCTAL CODE	150	151	152	153	154	155	156	157
DECIMAL CODE	104	105	106	107	108	109	110	111
HEX CODE	068	069	06A	06B	06C	06D	06E	06F
CHARACTER	p	q	r	s	t	u	v	w
OCTAL CODE	160	161	162	163	164	165	166	167
DECIMAL CODE	112	113	114	115	116	117	118	119
HEX CODE	070	071	072	073	074	075	076	077
CHARACTER	x	y	z	}	rule	}	~	DEL
OCTAL CODE	170	171	172	173	174	175	176	177
DECIMAL CODE	120	121	122	123	124	125	126	127
HEX CODE	078	079	07A	07B	07C	07D	07E	07F

Figure 10-2 US ASCII Character Set

HOST SELECTION OF PRINT PARAMETERS

Section 2 details local (control panel) selection of print parameters for each operating mode. Subsequent paragraphs in this section describe the escape sequences used to set the same parameters from the host device. (See Horizontal Tabs, Vertical Tabs, Form Length, Vertical Margins, Horizontal Pitch, and Vertical Pitch.)

To set print parameters for fanfold, bin 1, bin 2, or bin 3 mode, send:

1. The required Set Feeder Mode escape sequence.
2. The required print parameter escape sequence(s).

For example, send:

```
ESC [ 2 { (select bin 2 mode)
ESC [ 5 w (select 5 cpi)
ESC [ 66 t (select 66 lines)
```

to set 5 cpi and a form length of 66 lines for bin 2 sheet feeder mode.

HORIZONTAL PITCH—Horizontal pitch determines the width of printed characters as well as their spacing. Changes to horizontal pitch are only allowed at the start of a line. The following escape sequences set horizontal pitch.

NOTE

Ensure the correct feeder mode is selected before setting horizontal pitch.

ESCAPE SEQUENCE

FUNCTION/COMMENT

ESC [w	Select 10 cpi horizontal pitch.
ESC [1 w	Select 10 cpi horizontal pitch.
ESC [2 w	Select 12 cpi horizontal pitch.
ESC [3 w	Select 13.2 cpi horizontal pitch.
ESC [4 w	Select 16.5 cpi horizontal pitch.
ESC [5 w	Select 5 cpi horizontal pitch.
ESC [6 w	Select 6 cpi horizontal pitch.
ESC [7 w	Select 6.6 cpi horizontal pitch.
ESC [8 w	Select 8.25 cpi horizontal pitch.
ESC [9 w	Select 15 cpi horizontal pitch.
ESC [10 w	Select 7.5 cpi horizontal pitch.

HORIZONTAL TABS—Horizontal tab stops are associated with specific character columns. Therefore, changing the horizontal pitch changes

the position of horizontal tabs. The following escape sequences set or clear horizontal tabs.

NOTE

Ensure the correct feeder mode is selected before setting horizontal tabs.

ESCAPE SEQUENCE

FUNCTION/COMMENT

ESC H	Set horizontal tab stop at current column.
ESC [g	Clear horizontal tab stop at current column.
ESC [0 g	Clear horizontal tab stop at current column.
ESC [2 g	Clear all horizontal tab stops.
ESC [3 g	Clear all horizontal tab stops.
ESC [n u	Set horizontal tab stop at column n.
ESC [n ₁ ; n ₂ ...n _x u	Set horizontal tab stops at columns n ₁ , n ₂ ...n _x (u = 16).

Example:

```
ESC [ 2 g—Clears all set horizontal tabs.
ESC [ 6; 12; 18; 24; 30 u—Sets horizontal tabs at column
6, 12, 18, 24 and 30.
```

VERTICAL PITCH—Vertical pitch determines the spacing between lines, not the height of printed characters. Changing vertical pitch also clears vertical margins. The following escape sequences set vertical pitch.

NOTE

Ensure the correct feeder mode is selected before setting vertical pitch.

ESCAPE SEQUENCE

FUNCTION/COMMENT

ESC [z	Select 6 lpi vertical pitch.
ESC [1 z	Select 6 lpi vertical pitch.
ESC [2 z	Select 8 lpi vertical pitch.
ESC [3 z	Select 12 lpi vertical pitch.
ESC [5 z	Select 3 lpi vertical pitch.
ESC [6 z	Select 4 lpi vertical pitch.

VERTICAL TABS—Vertical tab stops are associated with specific line numbers, not physical positions on the paper. Thus, changing vertical pitch will change the physical location of vertical tabs. The following escape sequences set or clear vertical tab stops.

NOTE

Ensure the correct feeder mode is selected before setting vertical tabs.

ESCAPE SEQUENCE	FUNCTION/COMMENT
ESC J	Select vertical tab stop at current line.
ESC [1 g	Clear vertical tab stop at current line.
ESC [4 g	Clear all vertical tab stops.
ESC [n v	Set vertical tab stop at line n.
ESC [n1; n2...nx v	Set vertical tab stop at line n1, n2, ... nx (x 16).

Example:

ESC [4 g—Clears all vertical tabs.

ESC [6; 16; 26; 36 v—Sets vertical tabs at lines 6, 16, 26, and 36.

VERTICAL MARGINS—Printing is permitted only on lines within the inclusive top and bottom margins. When form length is changed, these margins are cleared; that is, the top margin is set to line one and the bottom margin is set to the form length. The following must be true to successfully set new vertical margins:

$$1 \leq \text{top margin} \leq \text{bottom margin} \leq \text{form length}.$$

If the current line is less than the top margin or the current line is greater than the bottom margin, the current line is set to the top margin. For example, a line feed performed at the bottom margin will execute a form feed.

NOTE

Ensure the correct feeder mode is selected before setting vertical margins.

The following escape sequence sets vertical margins.

ESCAPE SEQUENCE	FUNCTION/COMMENT
ESC [n r	Set top margin to line n.
ESC [; n r	Set bottom margin to line n.
ESC [n ₁ ; n ₂ r	Set top margin to line n ₁ , and set bottom margin to line n ₂ .

Example:

ESC [1 r—sets top margin to line 1.

ESC [; 66 r—sets bottom margin to line 66.

The following escape sequence can be sent at one time to set both top and bottom margins.

ESC [1; 66 r—sets the top margin to line 1 and the bottom margin to line 66.

FORM LENGTH—Form length is defined in lines, not physical units. Therefore, changing vertical pitch alters the physical form length. Forms may be from 1 to 192 lines in length. Changing form length clears vertical margins and defines the current line as line one. The following escape sequence sets form length.

NOTE

Ensure the correct feeder mode is selected before setting form length.

ESCAPE SEQUENCE	FUNCTION/COMMENT
ESC [n t	Set form length to n lines. Set top margin to line 1. Set bottom margin to line n. Set current line to line 1.

Example:

ESC [66 t—Sets the form length to 66 lines.

COUNTRY SET SELECTION—The Model 358-3,-4 is capable of printing character sets of eight countries. The escape sequences to select the country character sets are as follows:

ESCAPE SEQUENCE	FUNCTION/COMMENT
ESC (A	Select Great Britain character set.
ESC (B	Select USA character set.
ESC (2	Select Sweden/Finland character set.
ESC (3	Select Norway/Denmark character set.
ESC (K	Select Germany character set.
ESC (1	Select Italy character set.
ESC (R	Select France character set.
ESC (4	Select Spain character set.

NOTE

This parameter CANNOT be particularly set for the feeder bins.

UNDERLINE—The printer accepts start and stop underline commands. When a portion of the line is to be underlined, more than one pass of the print head is required. Once the underline is set, all following characters in the data stream are underlined until it is reset.

ESCAPE SEQUENCE	FUNCTION/COMMENT
ESC [4 m	Start underline.
ESC [m	Stop underline.
ESC [0 m	Stop underline.

REVERSE LINE FEEDS—The printer accepts reverse line feed commands using the escape sequence below in the **cut sheet mode only**.

ESCAPE SEQUENCE FUNCTION/COMMENT

ESC [n T Move n reverse line feeds.
Example: ESC [6 T—Move 6 reverse line feeds.

SUPERSCRIP/T/SUBSCRIPT—The printer accepts both subscript and superscript commands.

The subscript command (ESC K) causes a forward paper motion which effectively lowers the printline. Send ESC K **once** to (1) go to subscript from baseline, or to (2) return to baseline from superscript. Send ESC K **twice** to go from superscript to subscript.

The superscript command (ESC L) causes a reverse paper motion which effectively raises the printline. Send ESC L **once** to (1) go to superscript from baseline, or to (2) return to baseline from subscript. Send ESC L **twice** to go from subscript to superscript.

NOTE

If a paper motion command (e.g. FF or LF) is received while subscript/superscript is active, paper advances to a subsequent BASELINE.

ESCAPE SEQUENCE FUNCTION/COMMENT

ESC K Set subscript.
ESC L Set superscript.

10.4 SELECTING CHARACTER SETS

Control codes and escape sequences can be sent to select the primary character set, or one of the several alternate character sets.

SELECTING/DESELECTING THE ALTERNATE CHARACTER SETS—Host generated escape sequences and control codes are used to select/deselect the four alternate character sets, which are listed below:

- Customer programmable character set
- Downstream loaded character set
- Bidirectional multipass character set
- Unidirectional multipass character set

The customer programmable and downstream loaded character sets are entirely controlled by downstream loaded commands. Multipass can be controlled by downstream loaded command or, to a limited extent, by the **MULTIPASS** switch, located on the control panel. Refer to Section 11 for more information about switch-selectable multipass.

To select an alternate character set, send:
FIRST, an escape sequence that designates one of the alternate sets.

SECOND, the escape sequence/control code that invokes (causes printing of) the designated set.

The following escape sequences are used to **DESIGNATE** the alternate character sets:

ESCAPE SEQUENCE	CHARACTER SET DESIGNATED
ESC) 0	Customer Programmable
ESC) Sp @	Downstream Loaded
ESC) 1	Bidirectional Multipass
ESC) 2	Unidirectional Multipass

The following escape sequences/control codes are used to **INVOKE** the designated set:

CODE	COMMENT
SO	Used in ANSI Mode
ESC 3	Used in 703 Mode

The commands that designate and invoke an alternate set do not have to be sent as two contiguous pieces of data, but the designation command must always precede the invocation command.

Alternate character set printing begins on the first new line **AFTER** SO/ESC3 is received, and continues until:

- A different alternate set is designated **AND INVOKED**.
- The primary character set is designated **AND INVOKED**.

SELECTING/DESELECTING THE PRIMARY CHARACTER SET—The primary character set is invoked (selected) through the following codes:

CODE	COMMENT
SI	Used in ASCII mode.
ESC4	Used in 703 mode.

The primary set is deselected by selecting one of the alternate character sets.

10.5 PROGRAMMING CONSIDERATIONS

The printer is controlled by the host device which must be programmed to provide the proper instructions to the printer for the desired outputs. The following is a summary of items which should be considered when programming the printer.

- Elongated characters are printed only if the horizontal pitch is 10, 12, 13.2, 15, or 16.5 cpi and are automatically terminated at the end of a line.
- Underline is NOT terminated at the end of a line and continues until a stop underline command (ESC [m) is received.
- Depending on the setting of the 703 ANSI Feature the ESC 3, ESC 4, SO, SI, GS, RS, and US codes are either acknowledged or ignored.
- When the auto line feed after carriage return is disabled, paper is NOT advanced after printing. When in this mode all carriage return (CR) commands should immediately be followed by a line feed (LF) command to prevent overprinting.
- Sheet feeder mode selection governs the function of FF.

SECTION 11

PRINT GENERATION

11.1 GENERAL

Printing can be done in three modes: single-pass mode, multipass mode, or graphics mode. This section provides information about the character sets used in the single-pass and multipass modes, and a summary of the operation of the graphics mode.

11.2 PRIMARY CHARACTER SET

The primary character set is the basic character set for single-pass mode operation. The set contains 96 standard US ASCII characters plus 34 characters peculiar to seven international character sets. All characters in the set are printed in a 7 x 9 matrix format.

Pin fire coding for the primary character set is stored in EPROM U21, which is located on the format board.

NOTE

U21 stores pin fire data for both the primary and the customer programmable character sets. Addresses 0 (H)-4FF (H) are reserved for the primary set; addresses 500 (H)-7FF (H) are reserved for the customer programmable set.

8 consecutive bytes of memory are required to code a single character. Starting addresses for the 96 US ASCII characters can be determined by multiplying the ASCII character codes by the number 8. Refer to Figure 10-2 for character codes.

Example

Starting address for the US ASCII upper case "A":

$$\begin{array}{r} 41 \text{ (H) Character code, u.c. "A"} \\ \times 8 \\ \hline 208 \text{ (H) Starting address, u.c. "A"} \end{array}$$

Starting addresses for the international characters are determined the same way, but require the use of a translating table to determine character codes.

Any bytes in the primary reserved area (0 (H)-4FF (H) not used to code printable characters are coded zero (0).

The primary character set uses approximately 60% of the memory in EPROM U21. The remainder of the memory is used to store the customer programmable character set. Although the primary set is stored in an erasable PROM, **THE FACTORY PROGRAMMED CODING FOR THE PRIMARY CHARACTER SET SHOULD NEVER BE REPROGRAMMED BY THE CUSTOMER.**

CAUTION

Reprogramming the primary character set can cause the country code translation to be negated.

Refer to Section 10 for primary character set escape sequences.

11.3 CUSTOMER PROGRAMMABLE CHARACTER SET

The customer programmable character set is one of two alternate character sets for single pass mode operation. There are 96 characters in the set.

The characters in the set are printed in a 7 x 9 matrix format. The dots which form characters are impact printed by nine print wires in the print head. These nine wires are selectively fired as the print head moves across the paper.

The character set coding, which controls print head pin fire, is stored in 768 bytes in EPROM U21 on the format controller pcb. These bytes have addresses 500 (H)-7FF (H).

The programmable character set is programmed for 96 US ASCII characters when the printer is shipped from the factory. Customers who have the necessary expertise and equipment can reprogram the set, nearly doubling the number of characters that can be printed in single-pass mode.

NOTE

The character set holds 94 formed characters; the first and last characters **MUST** always be a "SPACE" [ASCII 20 (H)] character.

CHARACTER CODING—Characters in the customer programmable set are printed in a 7 x 9 matrix format. Individual characters are printed through the selective firing of the nine print head wires in seven consecutive volleys.

Figure 11-1 shows how one printed character of the set—a lower case “p”—is positioned on the matrix.

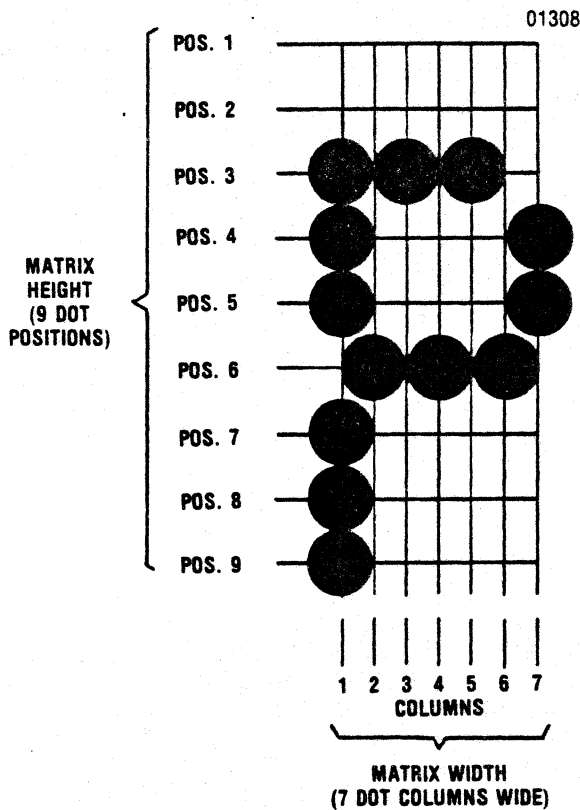

Figure 11-1 7x9 Matrix, Lower Case “p”

Note that the matrix is SEVEN DOT COLUMNS WIDE (each column is printed by one volley of pin fire) by NINE DOT POSITIONS HIGH (each dot is printed when one print wire is fired. Dot position 1 corresponds to print wire # 1, the top print wire in the head).

Notice that 13 dots form the lower case “p.” Other characters may use more or fewer dots, which will be positioned elsewhere on the matrix.

Since the matrix is 7x9, 63 dot positions are available for dot placement. Accordingly, each character requires 63 bits of memory to store pin fire data for character formation. The 63 bits used to store that data are always grouped as eight (8) contiguous bytes in the character set EPROM.

The format used to code the pin fire data in the contiguous bytes is as follows:

1. The first seven bytes control the firing of print wires 1 through 8. Byte 1 controls pin fire at dot

column 1 on the matrix. The next six bytes control fire at the remaining six columns on the matrix.

Within bytes, each bit controls the firing of the correspondingly numbered print wire. For example, bit 3 is used to control the firing of print wire #3 (third wire from top).

2. The eighth contiguous byte controls the firing of print wire #9. Bit 8 controls firing at dot column 1, and bits 7 through 2 control pin fires at dot columns 2-7, respectively. Bit 1 of the byte is ignored.

In all bytes a bit is coded “1” to cause a pin fire, and is coded “0” for no pin fire.

The coding for the lower case “p” shown in Figure 11-1 is as follows:

	BITS							
	8	7	6	5	4	3	2	1 (LSB)
First Byte	1	1	0	1	1	1	0	0
Second Byte	0	0	1	0	0	0	0	0
Third Byte	0	0	0	0	0	1	0	0
Fourth Byte	0	0	1	0	0	0	0	0
Fifth Byte	0	0	0	0	0	1	0	0
Sixth Byte	0	0	1	0	0	0	0	0
Seventh Byte	0	0	0	1	1	0	0	0
Eighth Byte	1	0	0	0	0	0	0	X

Figure 11-2 shows the eight contiguous bytes rearranged and with bits coded “1” highlighted.

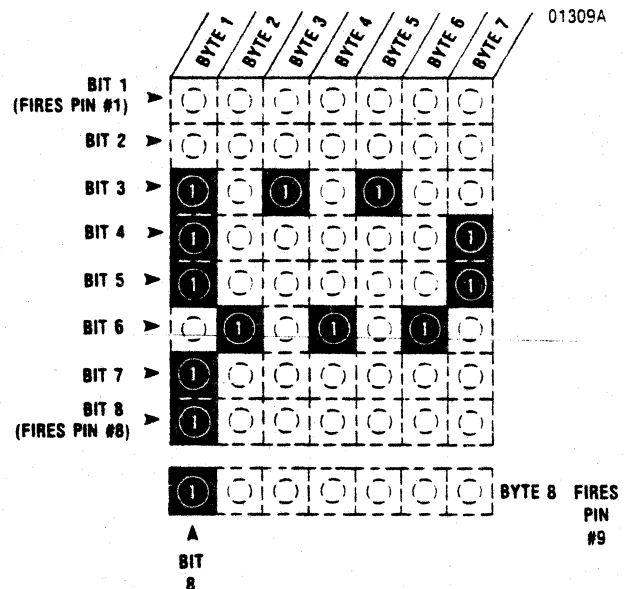

Figure 11-2 Character Coding, Lower Case “p”

Examination of the figure reveals the bits form a 7 x 9 matrix, like that shown in Figure 11-1. Note the correspondence between the position of the highlighted "I"s in the coding matrix, and the dots on the character matrix; the correspondence is one to one.

The coding format described above is used for each of the 96 characters in the set.

PROGRAMMING THE CUSTOMER PROGRAMMABLE SET—

The customer programmable character set is stored in EPROM U21, a 2716 type IC. A 2716 is reprogrammed by exposing the device to ultraviolet light to erase its content, then loading new data into the 2048 bits in the device. After erasure, all bits go to a "1" state. New data is entered by loading "0"s into the proper bits.

Customers who reprogram the customer programmable set **MUST RELOAD THE PRIMARY CHARACTER SET** [address 0 (H) – 4FF (H)] WITH THE SAME DATA THAT WAS STORED PRIOR TO ERASURE. Refer to paragraph 11.2 for addressing, and to the previous paragraph for coding format.

NOTE

The Model 358-3,-4 Technical Manual documents removal/replacement procedures and includes a complete set of assembly/schematic drawings.

The customer programmable character set, which is factory programmed for the standard 96 US ASCII character set, occupies addresses 500 (H) – 7FF (H).

As explained earlier, each character is assigned eight (8) contiguous addresses. The starting address for each character is determined by:

1. Determining the character code (refer to Figure 10-2).
2. Subtracting 20 (H) from the **HEX** character code.
3. Multiplying the obtained difference by eight (8).
4. Adding 500 (H) to the obtained product.

Example

Determining the starting address for the "QUOTES" character in the customer programmable set:

1.	22 (H)		ASCII code for "QUOTES"
2.	- 20 (H)		
	02 (H)		Difference
3.	x 8		
	10 (H)		Product
4.	+ 500 (H)		
	510 (H)		Starting Address

There are three important rules that apply to programming the customer programmable set:

- The first and last characters in the programmable set must always be coded as a **SPACE**; the remaining 94 characters can be programmed as printable characters.
- **NEVER** program a character that requires the same print wire to be fired in two consecutive print columns. **Printer hardware parameters are not broad enough to handle two consecutive firings of the same pin.**
- **NEVER** alter the factory programmed coding for the primary character set.

Refer to Section 10 for escape sequences (Selecting/Deselecting the Alternate Character Sets).

11.4 DOWNSTREAM LOADED CHARACTER SET

The downstream loaded character set is another alternate single pass character set. There are 191 characters in the set.

Characters in the set are printed in a 7 x 8 matrix format. Because the downstream loaded matrix is smaller than the customer programmable matrix (7 x 9) only eight of the nine print wires (wires 1-8) are fired to form characters.

Pin fire coding for the downstream loaded set is stored in RAM U16 on the format controller pcb. The formatter loads U16 after receiving and reformatting the downstream loaded character data sent from the host device.

NOTE

RAM U16 contains volatile memory and is erased whenever the printer is powered down.

CHARACTER SET LOADING—The following escape sequence must be sent to the printer to load the character set:

```

ESC      (1B H)
[        (5B H)
n        (three byte ASCII
         decimal number that
         corresponds to the
         number of characters to
         be loaded. First byte
         holds most significant
         digit).
x        (78 H)
  
```

The character data (an ASCII character string containing the dot pattern data for loading U16) then follows.

Fourteen bytes are used to describe each character being loaded. In each byte:

- Bits 1 (LSB)–4 are coded to control fire of pins 1–4 or pins 5–8.
- Bits 5, 6, and 7 are always 0, 1, and 0, respectively.
- Bit 8 is ignored.

Refer to Figure 11-3 for a graphic representation.

The formatter will assume the length of the string to be 14 times “n.” If a different number of bytes are sent the printer will deselect and error code 15E will display on the LCD.

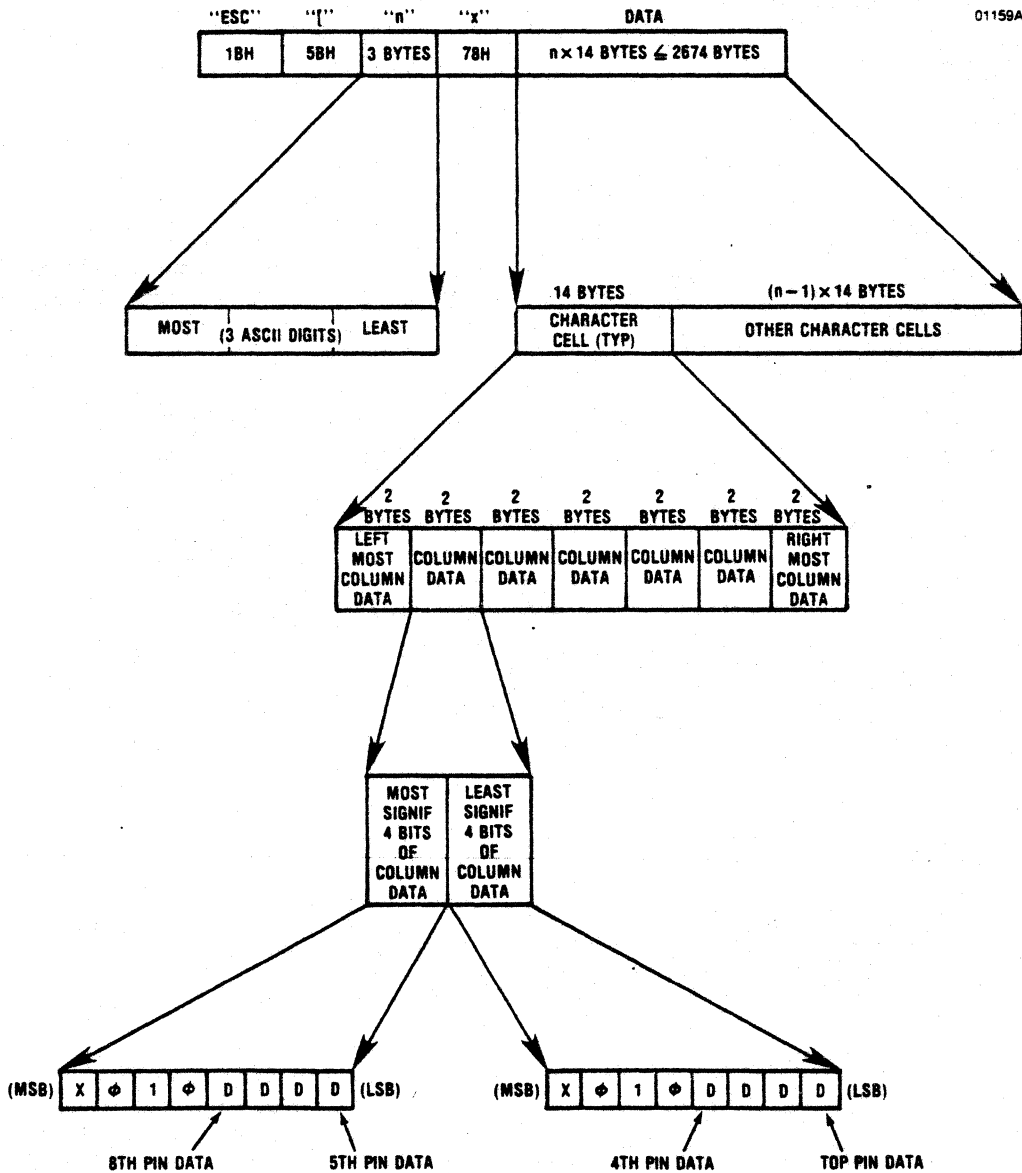

Figure 11-3 Control Escape Sequences to Load RAM Character Set

ADDRESSING CHARACTERS

The first 96 allowable characters are addressed during printing by ASCII codes 20 H through 7F H. 20 H is used to address the first character; subsequent characters are addressed by subsequent ASCII codes. The remaining 95 characters are addressed by ASCII codes A0H through FEH.

PROGRAMMING RULES

- **NEVER** load a character that requires the same print wire to be fired in two consecutive print columns.
- For the first 96 characters, always load the first and last characters (20 H and 7F H) as a space. Only 94 printable characters are allowed.
- For the remaining 95 characters, always load A0H as a space. Only 94 printable characters are allowed.
- In parallel, the bit 8 configuration must be selected "normal" (legend 3 on LCD).
- In serial, the data bit configuration must be set to "7 bits" (legend 2 on LCD) or to "8 bits" (legend 3 on LCD).

11.5 MULTIPASS CHARACTER SET

The multipass character set is essentially a double-pass, high resolution version of the primary character set. Characters in the multipass set are printed in a 15 x 16 matrix format. 10 or 12 cpi may be selected.

A multipass character is, in effect, two overlapping 15 x 8 characters. The first "character" is printed during the initial printing pass. The paper is then

advanced slightly, and the second "character" is printed over the first. Figure 11-4 illustrates an example of multipass character printing.

Pin fire data for the multipass character set is stored in EPROM U15 on the format controller pcb. U15 is divided into two sections. The first section (addresses 0 H-7FF H) contains pin fire data for first pass printing, while the second section (addresses 800 H-FFF H) stores data for the second pass.

The pin fire coding used for the multipass characters is involved and requires an in-depth understanding of the printer hardware parameters. Accordingly, **THE MULTIPASS CHARACTER SET SHOULD NOT BE REPROGRAMMED BY THE CUSTOMER.**

CAUTION

An improperly coded multipass character set can draw excessive current and result in component damage.

The multipass character set can be controlled by the host device or from the printer control panel.

Host control of multipass is described in Section 10. Refer to paragraph 10.4

The **MULTIPASS** switch on the control panel allows manual control of the multipass character set. The switch can only be used while the printer is deselected (off-line mode). Alternately pressing **MULTIPASS** selects/deselects the multipass

10517

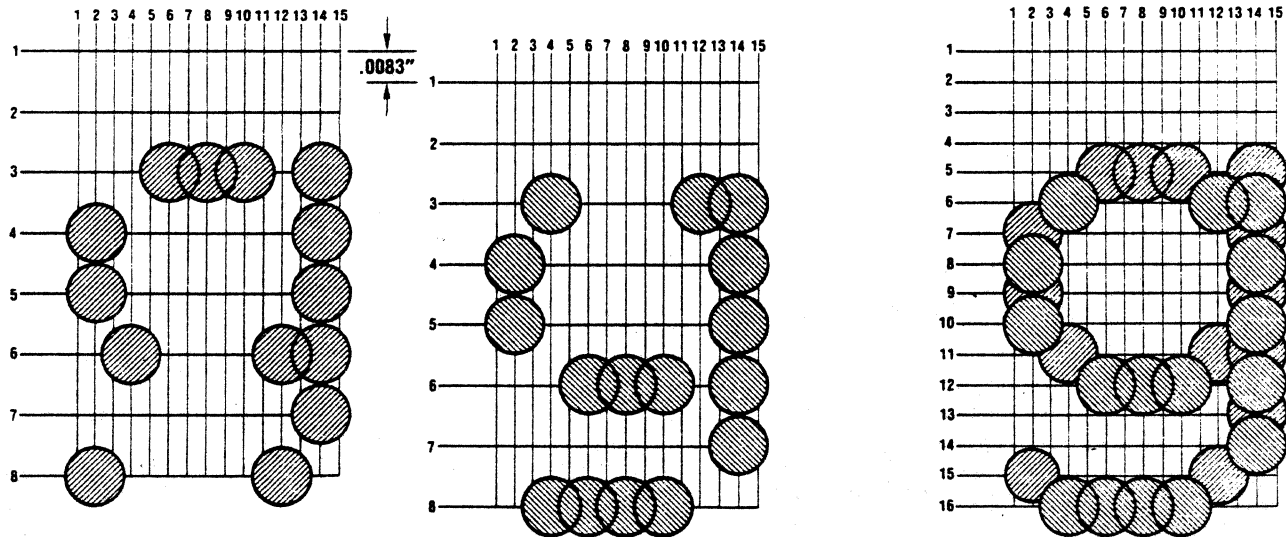

Figure 11-4 Multipass Printing, Lower Case "g"

character set, as indicated by the multipass indicator on the control panel. When the indicator is ON, the printer is in multipass mode and will print data (after the printer is placed on line) in the high quality, multipass mode. When the indicator is OFF, the printer is out of multipass mode, and will print data in single pass mode.

Switch selected multipass can be set for 10 or 12 cpi. For 12 cpi multipass, select (locally or via escape sequence) 12 cpi, then press **MULTIPASS**. For 10 cpi, select any density other than 12 cpi, then press **MULTIPASS**.

Unless the host device commands unidirectional printing, switch selected multipass defaults to bidirectional mode. If unidirectional printing is required, send ESC) 2—the unidirectional designation escape sequence—while the printer is on line. Subsequent switch selected multipass will be unidirectional.

NOTE

Once designated by the host, unidirectional multipass remains active until, (1) the host designates bidirectional printing, or (2) the printer is powered down.

11.6 GRAPHICS

The printer is placed in its graphics mode through downstream loaded commands. In the graphics mode pin fire is directly controlled by the host device. The printer merely responds to the pin-addressable graphics data it is sent and fires pins accordingly. No character sets are used in this mode.

Dot columns in the graphics mode are six (6) dot positions high. The top six (6) print head pins are selectively fired to form each column. Up to 872 columns may be printed in a single line. -

NOTE

The graphic aspect ratio is 66/72; i.e., 66 dots/inch horizontal, 72 dots/inch vertical.

GRAPHICS DATA CODING—64 different column patterns can be printed. Figure 11-5 shows all 64, and the decimal/hex code for each pattern. Note that the first graphic code is 21 H, the starting code in the ASCII printable range.

Graphic coding is sent as contiguous bytes of data, with column printing following in corresponding order. The eighth data byte sent, for example, controls pin fire at the eighth column of print.

Before the printer will accept pin-addressable data, one of two escape sequences must be sent to the printer to place it in graphics mode. One sequence initiates a unidirectional graphic mode and the other a bidirectional mode.

The unidirectional sequence, shown below, should be sent when high-resolution graphics are to be printed:

ESC	(1B, H)
%	(25, H)
0	(30, H)

1 N N N N N	● 32D 20H	● 33D 21H	○ 34D 22H	● 35D 23H	○ 36D 24H	● 37D 25H	○ 38D 26H	● 39D 27H
1 N N N N N	● 40D 28H	● 41D 29H	○ 42D 2AH	● 43D 2BH	○ 44D 2CH	● 45D 2DH	○ 46D 2EH	● 47D 2FH
1 N N N N N	● 48D 30H	● 49D 31H	○ 50D 32H	● 51D 33H	○ 52D 34H	● 53D 35H	○ 54D 36H	● 55D 37H
1 N N N N N	● 56D 38H	● 57D 39H	○ 58D 3AH	● 59D 3BH	○ 60D 3CH	● 61D 3DH	○ 62D 3EH	● 63D 3FH
1 N N N N N	● 64D 40H	● 65D 41H	○ 66D 42H	● 67D 43H	○ 68D 44H	● 69D 45H	○ 70D 46H	● 71D 47H
1 N N N N N	● 72D 48H	● 73D 49H	○ 74D 4AH	● 75D 4BH	○ 76D 4CH	● 77D 4DH	○ 78D 4EH	● 79D 4FH
1 N N N N N	● 80D 50H	● 81D 51H	○ 82D 52H	● 83D 53H	○ 84D 54H	● 85D 55H	○ 86D 56H	● 87D 57H
1 N N N N N	● 88D 58H	● 89D 59H	○ 90D 5AH	● 91D 5BH	○ 92D 5CH	● 93D 5DH	○ 94D 5EH	● 95D 5FH

Figure 11-5 Graphic Pin Address Codes

The bidirectional sequence, shown below, should be sent when speed is more important than exact pin registration:

ESC	(1B, H)
%	(25, H)
1	(31, H)

The printer print buffer can accept up to 872 bytes (one printed line) of graphic data. If more than 872 bytes are sent, the printer forces a carriage return. Subsequent data will then be printed:

- On the next line (after a line feed) if the automatic line feed feature is enabled (refer to Section 2).

or

- On the same line (overprint) if ALF is disabled.

Graphic lines shorter than 872 print columns are terminated by sending a carriage return. Again, depending on ALF selection subsequent data will be printed on the next line or as an overprint.

The printer responds to graphic line feed (LF) codes according to the print on paper motion configuration that is selected. Refer to Section 2.

Vertical margins are ignored in the graphics mode, as are escape sequences for underline and change in horizontal pitch.

The graphics mode is exited by invoking either the primary or an alternate character set. Any of the following four escape sequences may be used:

SO	(0E, H)	}	in ANSI
SI	(0F, H)		
ESC 3	(1B 33, H)	}	in 703
ESC 4	(1B 34, H)		

SAMPLE GRAPHIC CODING—Figure 11-6 illustrates a simple graphic formation printed in graphics mode. The graphic data that was sent to the printer to initiate the print is shown to the right.

The relationship between graphic coding and graphic printing is clearly shown in the figure.

Note that adjacent dots are used to form the graphic. **Consecutive pin fires are allowed in the graphics mode.**

01310

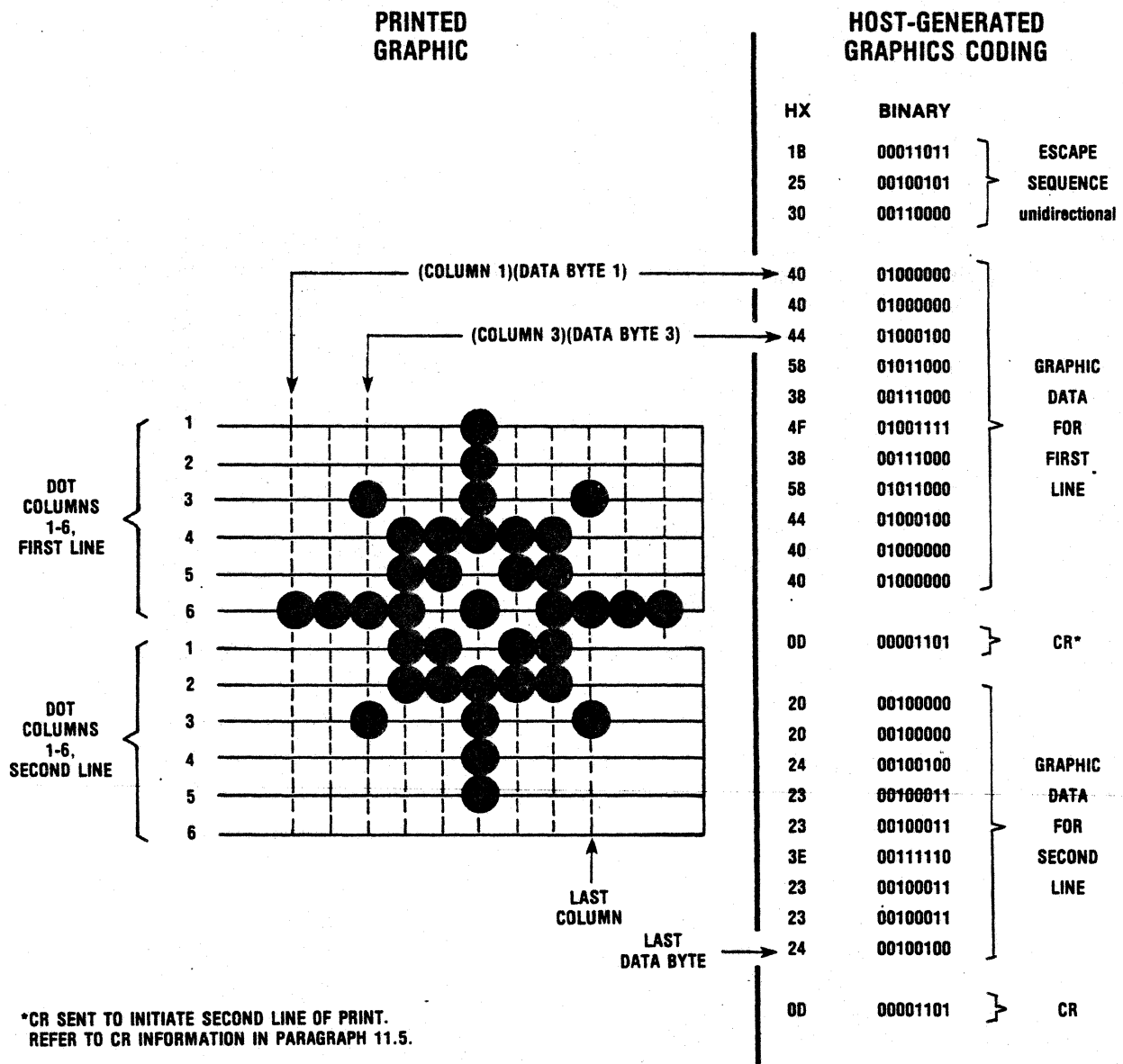

*CR SENT TO INITIATE SECOND LINE OF PRINT. REFER TO CR INFORMATION IN PARAGRAPH 11.5.

Figure 11-6 Graphics Coding/Printing

11.7 COLOR PRINTING

Characters and graphics can be printed in color when optional color ribbon cassettes are used in the printer. Two color cassettes are available—the standard color cassette, and the additive color cassette.

The standard color cassette contains a 70 yard long color ribbon. The ribbon is 1 inch wide. Four color tracks run the length of the ribbon. Track 1, the top track, is colored red; tracks 2, 3, and 4 are colored green, blue, and black, respectively.

The additive color cassette also contains a 70 yd. x 1 inch four track ribbon. Tracks 1 through 4 of this ribbon are colored yellow, magenta, cyan, and black, respectively.

Installing either cassette in the printer activates color sensing devices and causes the printer to automatically enter its color printing mode.

Once the printer is in color mode, ANSI standard escape sequences may be sent to control the ribbon shift mechanism mounted to the print head/carriage assembly. Sending an appropriate escape sequence causes the shift mechanism to move up or down until the specified color track is positioned in front of the print wires. The selected color is subsequently printed.

The ANSI standard escape sequences used to control ribbon shifts are as follows:

STANDARD COLOR CASSETTE

ESCAPE SEQUENCE	TRACK	COLOR
ESC [31 m	1	Red
ESC [32 m	2	Green
ESC [34 m	3	Blue
ESC [30 m	4	Black

ADDITIVE COLOR CASSETTE

ESCAPE SEQUENCE	TRACK	COLOR
ESC [33 m	1	Yellow
ESC [35 m	2	Magenta
ESC [36 m	3	Cyan
ESC [30 m	4	Black

Send the required color escape sequence ahead of the print command when selecting a color track. The subsequent ribbon shift will occur just before the print head starts moving to print the new line.

The ribbon cannot be shifted while a line is being printed. If you wish to print different colors on one line, you must “build up” the line color by color. Two printing passes are necessary for two colors, three passes for three colors, etc. This technique requires disabling automatic line feed and sending spaces in place of character/graphic patterns to be printed during a different pass.

Multiple pass printing can also be used to print secondary colors, like purple. To print purple using the standard color ribbon, send the escape sequence for red, the data, and a print command; then send the escape sequence for blue, the same data, and a print command. The overprint will produce purple print.

SECTION 12

OPTIONS AND ACCESSORIES

NOT AVAILABLE AT TIME OF PUBLICATION

APPENDIX A

SETTING HORIZONTAL TABS

A.1 INTRODUCTION

This appendix provides supplementary information for using the horizontal tab feature.

A.2 SETTING HORIZONTAL TABS; SINGLE DENSITY PRINT

Figure A-1 can be used to determine horizontal tab settings for various points on the form. The figure is basically a reduced reproduction of a printout showing print columns for the ten selectable print densities. Vertical markers and cpi labels in the figure are reference aids, and are not part of the original printout.

Refer to the figure and determine which column is located at the point you want as a tab stop. Set your tab for that column.

EXAMPLE

Assume you are printing at 10 cpi and want to set a stop 5" from left margin. Refer to the 10 cpi line in the figure and note that column 50 ends 5" from left margin. Set your tab for 50.

A.3 SETTING HORIZONTAL TABS; MIXED DENSITY PRINTING

Figure A-1 shows how columns of different densities align at various points on the form. As a result, the figure can be used to quickly deter-

mine the tab settings required to set one stop for two (or more) print densities.

EXAMPLE

Assume two densities are to be printed — 5 cpi for a column heading, and 10 cpi for data printed below the heading. Further assume the heading and data are to be tabulated 4" from left margin. Referring to figure, A-1, note tabs must be set for "20" (for 5 cpi header) and for "40" (for the 10 cpi data).

Precise tabulation always requires an exact alignment of the RIGHT edges of the print columns being tabulated. Refer to the 3" marker in the figure. Note that 5 cpi can be precisely tabulated with 10 cpi, but CANNOT be precisely tabulated with 7.5 cpi. When tabulating mixed density print, choose cpi combinations that will align at the points where stops are to be set.

The following cpi combinations offer the greatest flexibility for tabulation of two densities:

- 5 cpi/10 cpi
- 6 cpi/12 cpi
- 6.6 cpi/13.3 cpi
- 7.5 cpi/15 cpi
- 8.25 cpi/16.5 cpi

A-2

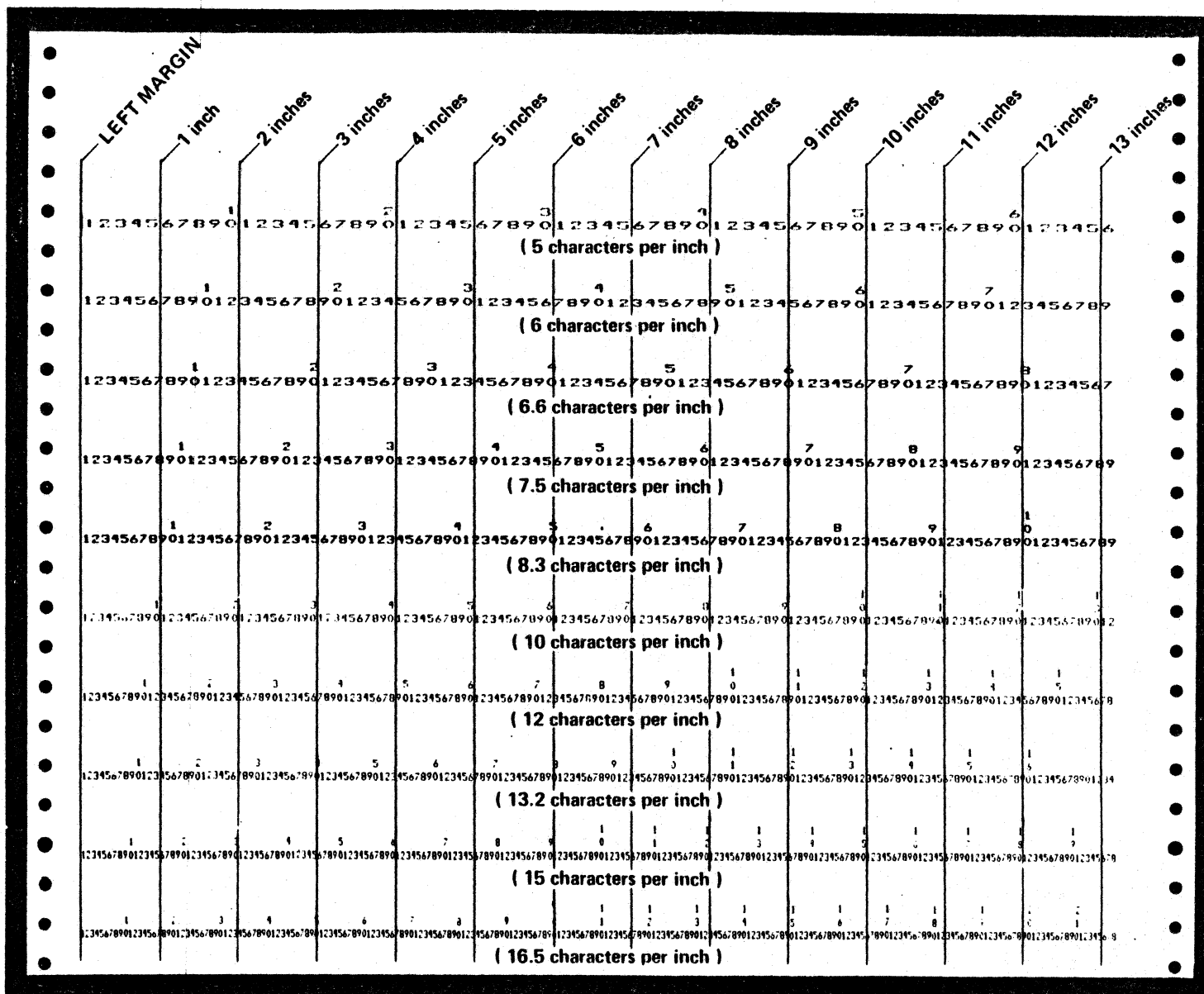

Figure A-1 Print Column Alignment For All Selectable Print Densities

APPENDIX B

INTERNATIONAL CHARACTERS

B.1 GENERAL

Thirty four (34) international characters can be printed by selecting different country character sets and sending appropriate character codes.

characters, select the appropriate country character set and code characters as shown below.

The international characters that are particular to each country set are shown below. The coding associated with each character is listed below the characters. To print the international

Refer to Section 2 for local selection of character sets, or to Section 10 for country set escape sequences.

USA COUNTRY CHARACTER SET

CHARACTER	†	@	[\]	^	_	`	{		}	~
OCTAL CODE	43	100	133	134	135	136	137	140	173	174	175	176
DECIMAL CODE	35	64	91	92	93	94	95	96	123	124	125	126
HEX CODE	23	40	5B	5C	5D	5E	5F	60	7B	7C	7D	7E

FRANCE COUNTRY CHARACTER SET

CHARACTER	£	à	°	ƒ	§	^	_	`	é	ù	è	..
OCTAL CODE	43	100	133	134	135	136	137	140	173	174	175	176
DECIMAL CODE	35	64	91	92	93	94	95	96	123	124	125	126
HEX CODE	23	40	5B	5C	5D	5E	5F	60	7B	7C	7D	7E

UNITED KINGDOM COUNTRY CHARACTER SET

CHARACTER	£	@	[\]	^	_	`	{		}	-
OCTAL CODE	43	100	133	134	135	136	137	140	173	174	175	176
DECIMAL CODE	35	64	91	92	93	94	95	96	123	124	125	126
HEX CODE	23	40	5B	5C	5D	5E	5F	60	7B	7C	7D	7E

GERMANY COUNTRY CHARACTER SET

CHARACTER	£	§	Ä	Ö	U	^	_	`	ë	ö	ü	ß
OCTAL CODE	43	100	133	134	135	136	137	140	173	174	175	176
DECIMAL CODE	35	64	91	92	93	94	95	96	123	124	125	126
HEX CODE	23	40	5B	5C	5D	5E	5F	60	7B	7C	7D	7E

ITALY COUNTRY CHARACTER SET

CHARACTER	£	§	°	é	ì	^	_	ù	à	ò	è	ì
OCTAL CODE	43	100	133	134	135	136	137	140	173	174	175	176
DECIMAL CODE	35	64	91	92	93	94	95	96	123	124	125	126
HEX CODE	23	40	5B	5C	5D	5E	5F	60	7B	7C	7D	7E

SWEDEN/FINLAND COUNTRY CHARACTER SET

CHARACTER	£	É	Ä	Ö	Å	U	_	`	ë	ö	ä	ü
OCTAL CODE	43	100	133	134	135	136	137	140	173	174	175	176
DECIMAL CODE	35	64	91	92	93	94	95	96	123	124	125	126
HEX CODE	23	40	5B	5C	5D	5E	5F	60	7B	7C	7D	7E

DENMARK/NORWAY COUNTRY CHARACTER SET

CHARACTER	£	@	Æ	Ø	Å	U	_	`	Æ	Ø	ä	ü
OCTAL CODE	43	100	133	134	135	136	137	140	173	174	175	176
DECIMAL CODE	35	64	91	92	93	94	95	96	123	124	125	126
HEX CODE	23	40	5B	5C	5D	5E	5F	60	7B	7C	7D	7E

SPAIN COUNTRY CHARACTER SET

CHARACTER	£	§	í	ñ	¿	á	é	`	í	ñ	ó	ó
OCTAL CODE	43	100	133	134	135	136	137	140	173	174	175	176
DECIMAL CODE	35	64	91	92	93	94	95	96	123	124	125	126
HEX CODE	23	40	5B	5C	5D	5E	5F	60	7B	7C	7D	7E

OPTIONS/ACCESSORIES ORDER FORM (350 SERIES PRINTERS)

CENTRONICS PART NUMBER	OPTION / ACCESSORY DESCRIPTION	QUANTITY ORDERED	LIST PRICE	ITEM TOTAL
<p style="font-size: 2em; opacity: 0.5; transform: rotate(-15deg);">NOT AVAILABLE AT TIME OF PUBLICATION</p>				

* Prices not available at time of publication.

SALES TAX
ORDER TOTAL

SHIP TO:

Dept.	Phone Number
Firm Name	
Address	
City	State Zip
Customer Number	Purchase Order Number
Ordered by	

BILL TO: (if different from "SHIP TO")

Dept.	Phone Number
Firm Name	
Address	
City	State Zip
Customer Number	
Attention of	

PAYMENT METHOD:

- UPS COD
 CHECK ENCLOSED (We pay freight)
 BILL ME (Current CDCC customers only)

PAYMENT TERMS:

For orders less than \$100.00:

Will be shipped UPS COD; unless payment for the full amount of the order, including sales tax, is enclosed.
With prepayments we pay the shipping costs.

For orders in excess of \$100.00:

Same terms as above; or, if you currently have an account with Centronics, we can bill you.

Prices subject to change without notice.

Fold

BUSINESS REPLY MAIL
No Postage Necessary if Mailed in USA

First Class
Permit 31
Hudson, N.H.
03051

Postage will be paid by—

CENTRONICS[®]
data computer corporation
Hudson, New Hampshire 03051



ATTN: PARTS/ACCESSORIES CUSTOMER SERVICE

Fold

READERS COMMENTS

Publications Title MODEL 358-3,-4 USER MANUAL

Publications No. 37403591-9100 Revision 1 Date MAY 1983

List PCP's, if any, received with manual: _____

Name _____ Company _____

Address _____ City _____ State _____ Zip _____

The intent of this manual is to provide accurate and meaningful information to help you properly operate and efficiently maintain equipment manufactured by Centronics Data Computer Corp. To this end, we welcome your comments regarding any errors, discrepancies or omissions you may have discovered, or any suggestions for improving the overall manual. This postage-paid form is provided for your convenience. Your comments will be appreciated and should be a useful input at the next revision of this manual.

TECHNICAL OR CLERICAL ERRORS:

(Specify Page Numbers)

SUGGESTIONS FOR IMPROVEMENT:

CENTRONICS
data computer corp.
Hudson, New Hampshire 03051
Telephone (603) 883-0111

Fold



NO POSTAGE
NECESSARY
IF MAILED
IN THE
UNITED STATES

BUSINESS REPLY CARD
FIRST CLASS PERMIT NO. 31 HUDSON, N.H. 03051

Postage will be paid by addressee:

CENTRONICS
data computer corp.
1 Wall Street
Hudson, NH 03051

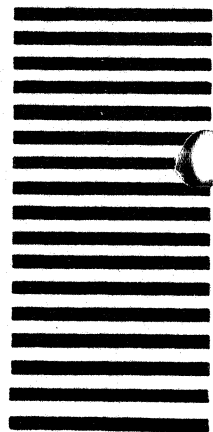

ttn: Technical Publications

Fold

CENTRONICS®

data computer corp.

Hudson, New Hampshire 03051

Telephone (603) 883 - 0111