

- 87 Thermal design, Part 4: forced air cooling
- 102 Universal wideband load simulates complex impedances
- 107 How to select the right microwave counter

Electronics®



1420 TCH999 995A8 JUN74
 STATE TECHNICAL INSTITUTE
 LIBRARY PERIODICALS 0-10992
 MEMPHIS TN 38134

LIBRARY
 STATE TECHNICAL INSTITUTE
 AT MEMPHIS
**BRINGING
 SIGHT
 TO THE BLIND**

State

Maddox Speaks.

DAC's make the difference in displays.

Some really *clear, sharp* pictures are being generated for demanding computer CRT Display jobs like Air Traffic Control, Avionic Heads-Up, and others.

To get sharp, clean output on high speed X-Y deflection displays you have to start with good spot definition and intensity and then drive it with a clean deflection signal. And that's where high-speed display DAC's come in.

Here's how.

Display DAC's convert digital position commands to analog voltage levels which will position the spot on the CRT face. New commands are usually clocked in at a steady update rate. The spot is positioned to the start of a line or character and then moved by progressive commands to draw the line.

If the DAC's behave, all is well, but often lines wiggle, and show intensity variations.

Who's the culprit?

Glitch, (transient *spike* or bump in the DAC output) and *differential non-linearity*, (a wrong size step in a series of steps).

Display DAC's are "de-glitched" to achieve very low output glitch values, and are designed to have damn good differential linearity.

How to define spec limits?

First, determine maximum allowable glitch voltage as measured through a test filter which simulates your deflection circuit's passband. The test filter is the key. You can even lump together the effects of glitch and differential non-linearity. Then, ramping the DAC and comparing its band-limited output to an

ideal ramp, you can check the errors. And after limits are set for intensity variation and wiggle, you can graphically arrive at ramp error limits for the DAC's.

Among other things.

You can also have an inherent lack of line fidelity due to the staircase-like DAC output. Smaller steps through greater DAC resolution will help. But beware, for the limits of maximum available update rate and minimum picture refresh rate set a resolution limit for line drawing. We can show you some filter techniques that can improve ramp fidelity by 10 to 1 or more, solving this staircase problem.

Settling is really important, too, and long settling tails must be absent so that line starting points will land where you planned.

Things like large-signal settling time, slew rate, zero offset, large scale linearity, and scale factor can normally be obtained much better than available deflection circuits, so use care; don't over-specify the DAC's. Save yourself some money.

Talk to the experts.

There are a lot more parameters to be considered in specifying high-speed display DAC's, so if you are into this, or going to be, probably the best approach is to consult us. After all, we have standard products such as our 12 or 13 bit DAC's (Models 4014 and 4017), and a lot of display knowledge and real experience. We've built and shipped more high-speed display DAC's than anybody else in the world.

Telephone, toll-free (800) 225-7883, in Mass. (617) 329-1600. Or write us, Dedham, Mass. 02026. In Europe, Tel. 73.99.88, Telex: 25881. Or write, 1170 Brussels, Belgium.

 **TELEDYNE
PHILBRICK**

Circle 900 on reader service card

Ed Maddox, Sr. Engineer



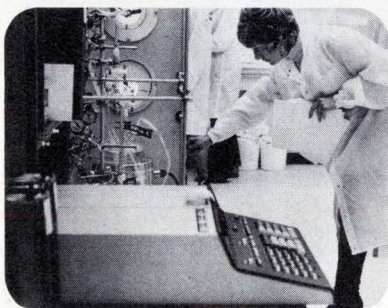
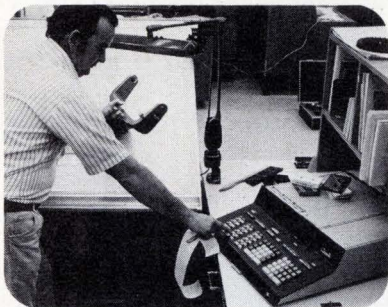

New HP 9821: More Straight Talk... More Memory.

Here's a no-nonsense approach to problem solving, a computing calculator that talks your language — the algebraic symbols, formulas, and English language notations you use in your work. Just enter your problem as you'd write it, press the Execute key, and there's your answer on the alphanumeric display or on the clearly labeled printer tape. Programming this new 9821 is as easy as jotting down a formula.

More memory — 167 registers for user storage, plus an internal cassette, make the basic 9821 not just conversational, but powerful. Powerful enough to solve 16 simultaneous equations — without the cassette. Slip in the cassette and you're only limited by your programming ingenuity. You can store programs and data on the

same tape. And a program linkage lets you handle any size program because it automatically calls in each segment for processing at the proper time.

And you'll find other features that make the 9821 your kind of calculator: A modular keyboard that lets you define the functions of the keys. Complete syntax error checking to prevent erroneous entries. Expandable up to 1,447 registers for program or data storage (according to the way you allocate it). A programmable tone signal for error alerts and progress monitoring. And — especially important — a complete line of Series 9800 peripherals.

Perhaps best of all, this computer-like capability comes at a calculator price — \$4975*. So take a good look at the 9821.

Send in this coupon for more information or a hands-on demonstration.

094/6

*Domestic U.S.A. Price Only.



Sales, service and support in 172 centers in 65 countries.
P.O. Box 301, Loveland, Colorado 80537

Please Tell Me More About The HP 9821
 Info Only Hands-on Demo
 I think I can use an HP 9821 for _____

Name _____
 Company _____
 Address _____
 City _____ Phone _____
 State _____ Zip _____

Hewlett-Packard Co.
 P.O. Box 301, Loveland, Colo. 80537

E1/74

SURPRISE!

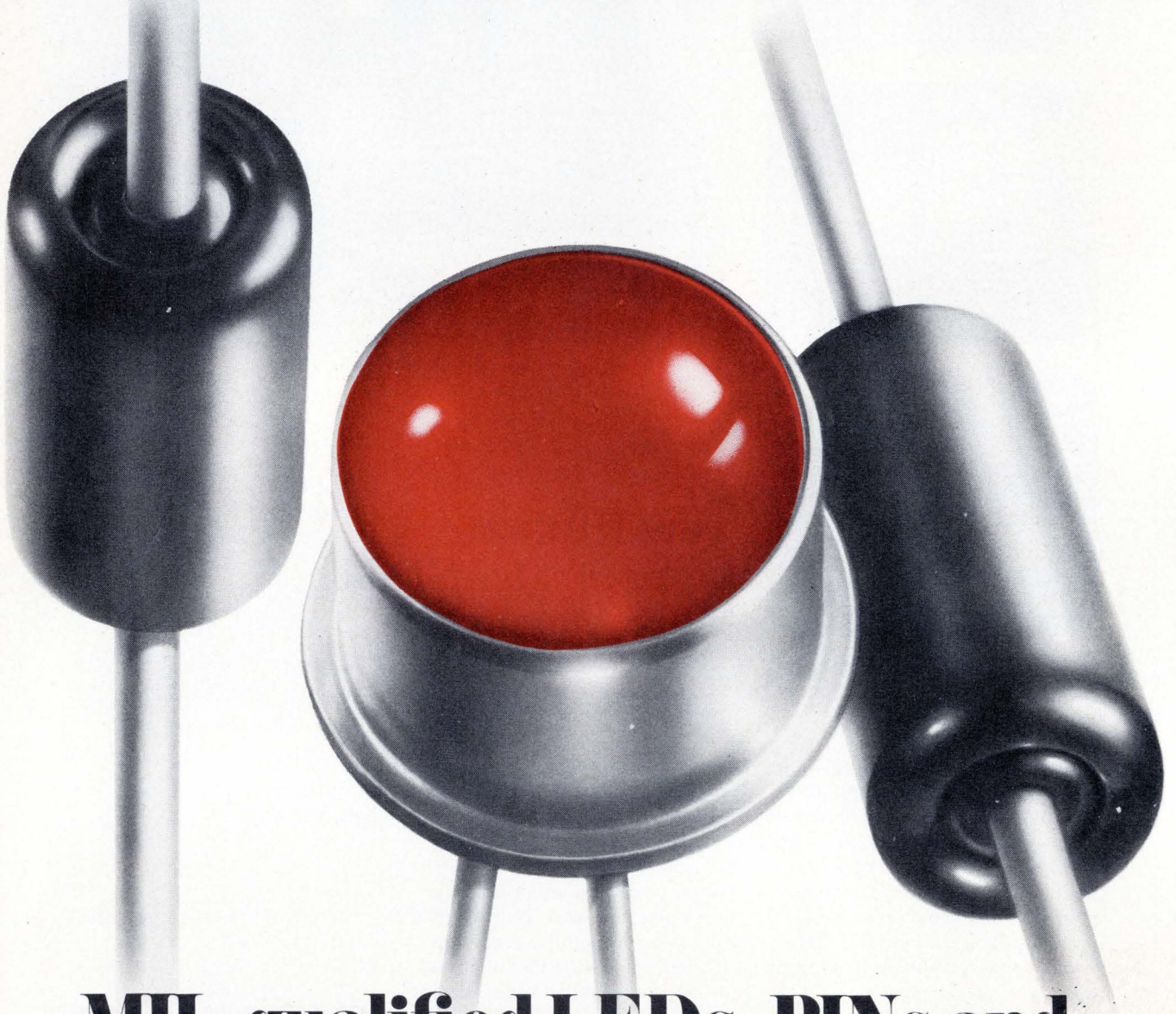

MIL-qualified LEDs, PINs and Schottkys right off the shelf.

Now HP can offer you military-qualified LED lamps, PIN diodes and Schottky diodes right from stock. Our LEDs are just right for applications needing a brilliant, long-life indicator. Our PIN diodes are ideal for attenuating and our Schottkys are designed for high level detection, switching or gating. In addition to military-qualified devices, HP provides standard high reliability test programs, patterned after MIL-S-19500, for many more products. For more information, contact your nearby HP field engineer.

TYPE	PART NO.	GOV'T DESIGNATION	MIL SPECIFICATION
SCHOTTKY	5082-2800	JAN/JANTX 1N5711	MIL-S-19500/444
PIN	5082-3001	JAN/JANTX 1N5719	MIL-S-19500/443
LED LAMP	5082-4420	JAN/JANTX 1N5765	MIL-S-19500/467

01334

HEWLETT  PACKARD

Sales and service from 172 offices in 65 countries.
1501 Page Mill Road, Palo Alto, California 94304

- 29 **Electronics Review**
SOLID STATE: Bipolar logic moves toward LSI, 29
Sharp's ICs use double diffusion, 30
GOVERNMENT: FCC's Hinchman backs competition for AT&T, 31
COMPONENTS: Solid-state oscillators sweep X, Ku bands, 31
PACKAGING: Elastic conductors help package watches, 32
COMMUNICATIONS: U. S.-Japan team to make ground stations, 34
OPTICS: Waveguide, coupler shrink optics, 34
NEWS BRIEFS: 36
COMMERCIAL ELECTRONICS: Scientific calculators star at CES, 38
Hamilton auto tester uses MOS LSI, 40
- 53 **Electronics International**
GREAT BRITAIN: Pocket slide rule has only 18 keys, 53
AROUND THE WORLD: 53
- 67 **Probing the News**
COMPANIES: Need custom design? Do it yourself, 67
CONSUMER ELECTRONICS: TV under the safety gun, 70
SOLID STATE: Nitride makes progress, 72
COMPUTERS: A calculator that's almost a computer, 74
- 81 **Technical Articles**
MEDICAL ELECTRONICS: Data processing, LSI to help blind "see," 81
THERMAL DESIGN: Forced-air cooling in high-density systems, 87
DESIGNER'S CASEBOOK: Series regulator supplies up to 10 A, 90
Multiphase clock produces nonoverlapping pulses, 91
Phase-locked loop adjusts to varying signal conditions, 91
INSTRUMENTATION: Measuring fast pulses, 94
CIRCUIT DESIGN: Simulating a TTL monostable multivibrator, 98
CIRCUIT TESTING: Impedance simulator provides wideband loads, 102
INSTRUMENTATION: How to choose a microwave counter, 107
ENGINEER'S NOTEBOOK: Bipolar pair simulates unijunction, 113
Program analyzes all-resistive dc circuits, 114
- 121 **New Products**
IN THE SPOTLIGHT: Counter measures to 500 MHz directly, 121
Peripherals broaden calculator's role, 125
PACKAGING & PRODUCTION: Card-cage system is flexible, 126
DATA HANDLING: User's kit programs calculators, 133
SEMICONDUCTORS: Isoplaner C-MOS circuits offer high drives, 141
SUBASSEMBLIES: A-d converter gives 12-bit accuracy, 149

Departments

- Publisher's letter, 4
Readers comment, 6
40 years ago, 8
People, 14
Meetings, 20
Electronics newsletter, 25
Washington newsletter, 49
Washington commentary, 50
International newsletter, 55
Engineer's newsletter, 116
New literature, 154

Highlights

The cover: Artificial sight for the sightless, 81

Electrodes implanted in the brain and linked to photosensors in a glass eye will enable a blind person to see black-and-white images, once details of the necessary data processing and LSI techniques have been worked out. Potentially, cost is low enough to bring the device within reach of all who need it. Art Director Fred Sklenar created the cover.

TV-set safety issue flares up again, 70

The Consumer Product Safety Commission has TV-set manufacturers fearful that new, wide-ranging safety regulations will be set up after February hearings. Makers contend that shock and fire data is being over-interpreted, but commission chairman Richard O. Simpson (p. 14) disagrees.

How best to measure fast pulses, 94

At least six factors, including accuracy, repetition rate, and cost, must be weighed in choosing between the three types of instrument that capture and analyze a fast pulse.

Universal load simulator works over wide band, 102

To assist in the design and testing of audio and microwave equipment, a new technique simulates any value of complex impedance over decade bandwidths.

And in the next issue . . .

A low-cost graphic terminal . . . automotive radar for actuating safety devices . . . a new ion implant technology.

EDITOR-IN-CHIEF: Kemp Anderson

EXECUTIVE EDITOR: Samuel Weber

MANAGING EDITORS: Lawrence Curran, *News*;
Arthur Erikson, *International*

SENIOR EDITORS: John Johnsrud,
H. Thomas Maguire, Laurence Altman
Ray Connolly

ART DIRECTOR: Fred Sklenar

ASSOCIATE EDITORS: John N. Kessler,
Howard Wolff, Gerald M. Walker

DEPARTMENT EDITORS

Aerospace: William F. Arnold
Circuit Design: Lucinda Mattera
Communications & Microwave:
Lyman J. Hardeman
Components: Joel DuBow
Computers: Wallace B. Riley
Consumer: Gerald M. Walker
Industrial: Alfred Rosenblatt
Instrumentation: Michael J. Riezenman
Military: Ray Connolly
New Products: H. Thomas Maguire
Packaging & Production: Stephen E. Grossman
Solid State: Laurence Altman
Special Issues: Harry R. Karp

COPY EDITORS: Margaret Eastman,
Everett C. Terry

ASSISTANT EDITOR: Marilyn Offenheiser

ART: Charles D. Ciatto, *Associate Director*
Patricia Cybulski, *Assistant Director*

PRODUCTION EDITOR: Arthur C. Miller

EDITORIAL SECRETARIES: Janet Annunziata,
Julie Gorgoglione, Penny Roberts

FIELD EDITORS

Boston: Gail Farrell
Los Angeles: Paul Franson (Mgr.)
Midwest: Larry Armstrong (Mgr.)
New York: Alfred Rosenblatt (Mgr.)
San Francisco: Judith Curtis
Washington: Ray Connolly (Mgr.),
William F. Arnold

Frankfurt: John Gosch
London: Michael Payne
Paris: Arthur Erikson
Tokyo: Charles Cohen

McGRAW-HILL WORLD NEWS

Director: Walter A. Stanbury
Bonn: Robert Ingersoll;
Brussels: James Smith;
London: Marvin Petal;
Milan: Peter Hoffmann, Andrew Heath;
Moscow: Axel Krause;
Paris: Michael Johnson, Richard Shepherd;
Stockholm: Robert Skole;
Tokyo: Mike Mealey

PUBLISHER: Dan McMillan

ADVERTISING SALES MANAGER: Pierre J. Braudé

ADVERTISING SALES SERVICE MANAGER:
Wallis Clarke

BUSINESS MANAGER: Stephen R. Weiss

CIRCULATION MANAGER: George F. Werner

MARKETING SERVICES MANAGER:
Tomlinson Howland

If anyone still needed proof of the pervasiveness of electronics, we suggest he turn to page 81. There, we've detailed how electronics is helping bring sight to the blind.

Even in its present developmental stage, the project is a fascinating one. The University of Utah team that is working on the artificial-vision program is not simply trying to find an alternative to the complex eye-nerve-brain visual chain, but to duplicate it.

They see solid-state image arrays replacing the eye's retina—actually attached to and moved by the eye's muscles. They see microprocessor chips, mounted in an eyeglass frame, decoding the visual data for transmittal to the brain. And they see electrodes implanted in the brain stimulating the sensation called sight.

In fact, with computers standing in for the image array and the microprocessor, the team has not only succeeded in stimulating visual patterns in the brains of blind volunteers, but has also started compiling data on the multitude of parameters that need to be pinned down before going on to device design.

Yet, according to William Dobbelle, who is director of the university's neuroprotheses program, off-the-shelf components could do the job. Here's another example of electronics technology developed for one function, say for defense or space exploration, being ready and waiting to take on other tasks in the service of mankind.

The harnessing of electronics technology is key to the artificial-eye project, and the composition of

the team of authors reflects that. Its leader is a biophysicist with an interest in electronics.

The six other team members include a physical chemist, two physicists, and three electronics engineers. They come from the electronics industries, having held such positions as director, associate director, and technical director of R&D laboratories. One member of the team was in a microprocessor development group, another is involved in computer graphics technology, and another specializes in ion-implantation technology. And, for most of the team members, circuit design and IC processing are the everyday challenges.

In fact, our first introduction to their work was when Solid State Editor Larry Altman heard about their processing achievements and contacted them for details on their n-channel ion-implantation process. After talking with them about that, he asked what they planned to use it for—and found the application every bit as interesting as the process itself. Details on the n-channel work, by the way, are scheduled for publication in the next issue. And as the project, which may later turn to the deaf, progresses, you can be sure we'll keep you posted.

The index of articles published in *Electronics* in 1973 will be available shortly. For a copy, circle number 340 on the reader service card inside the back cover.

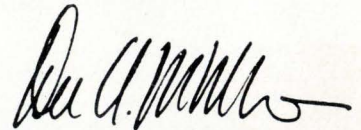

January 24, 1974 Volume 47, Number 2
92,847 copies of this issue printed

Published every other Thursday by McGraw-Hill, Inc. Founder: James H. McGraw 1860-1948. Publication office 1221 Avenue of the Americas, N.Y., N.Y. 10020; second class postage paid at New York, N.Y. and additional mailing offices.

Executive, editorial, circulation and advertising addresses: Electronics, McGraw-Hill Building, 1221 Avenue of the Americas, New York, N.Y. 10020. Telephone (212) 997-1221. Teletype TWX N.Y. 710-581-5234. Cable address: MCGRAWHILL N.Y.

Subscriptions limited to persons with active, professional, functional responsibility in electronics technology. Publisher reserves the right to reject non-qualified requests. No subscriptions accepted without complete identification of subscriber name, title, or job function, company or organization, including product manufactured or services performed. Subscription rates: qualified subscribers in the United States and possessions, Canada, and Mexico \$9.00 one year, \$18.00 three years; all other countries \$25.00 per year, except Japan \$50.00 per year and Brazil \$40.00 per year, including air freight. Limited quota of subscriptions available at higher-than-basic rate for persons outside of field served, as follows: U.S. and possessions and Canada, \$25.00 one year; all other countries \$50.00. Single copies: United States and possessions and Canada, 1.00; all other countries, \$1.75.

Officers of the McGraw-Hill Publications Company: John R. Emery, President; J. Elton Tuohig, Executive Vice President-Administration; Gene W. Simpson, Group Publisher-Vice President; Senior Vice Presidents: Ralph Blackburn, Circulation; Walter A. Stanbury, Editorial; John D. Hoglund, Controller; David G. Jensen, Manufacturing; Gordon L. Jones, Marketing; Jerome D. Luntz, Planning & Development.

Officers of the Corporation: Shelton Fisher, President; Wallace F. Traendly, Group President, McGraw-Hill Publications Company and McGraw-Hill Information Systems Company; Robert N. Landes, Senior Vice President and Secretary; Ralph J. Webb, Treasurer.

Title registered in U.S. Patent Office; Copyright © 1974 by McGraw-Hill, Inc. All rights reserved. The contents of this publication may not be reproduced either in whole or in part without the consent of copyright owner.

Subscribers: The publisher, upon written request to our New York office from any subscriber, agrees to refund that part of the subscription price applying to copies not yet mailed. Please send change of address notices or complaints to Fulfillment Manager; subscription orders to Circulation Manager, Electronics, at address below. Change of address notices should provide old as well as new address, including postal zip code number. If possible, attach address label from recent issue. Allow one month for change to become effective.
Postmaster: Please send form 3579 to Fulfillment Manager, Electronics, P.O. Box 430, Hightstown, N.J. 08520.

the **KEPCO** **JMK**

is the best system power supply you can buy

It's not (hardly) a stripped-down 'OEM module' and we didn't really design it as just another lab-bench supply (though lots of people use them that way).

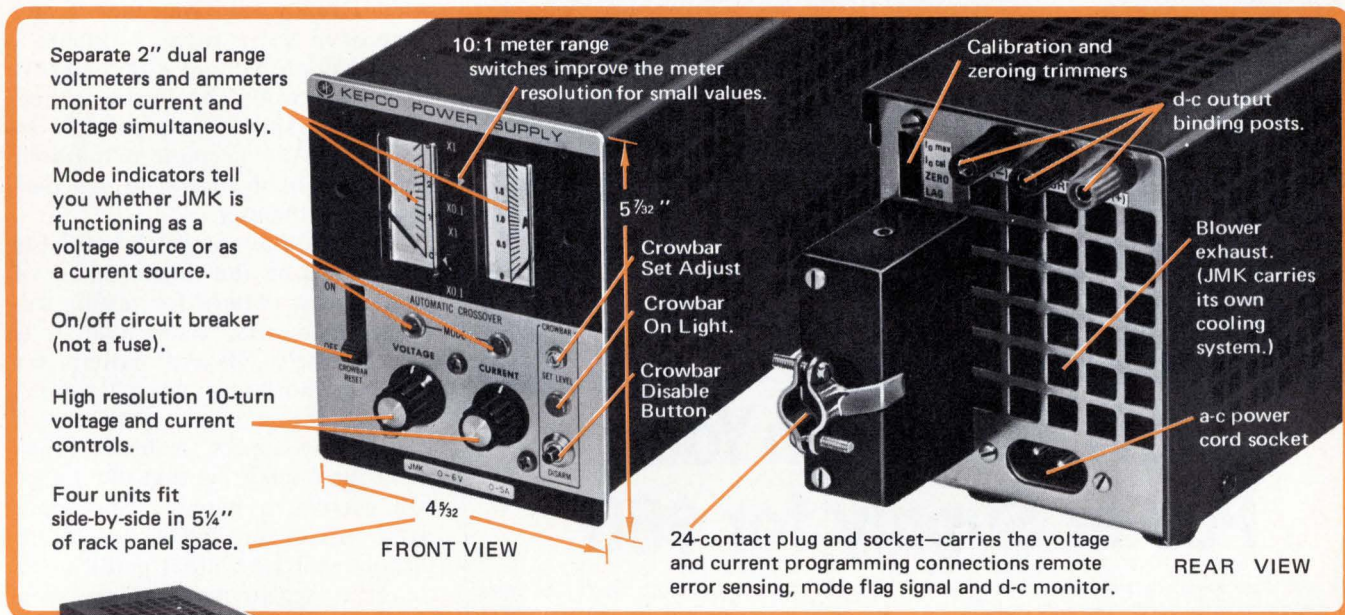

Kepco designed JMK to answer the special needs of the system designer for practical rack-mount systems power supplies.

The shape of JMK, for example, minimizes precious panel space—four of them will fit in a 5 1/4" high drawer (Model RA-24) which has provision for slide mounting. The connections to JMK are all at the rear so they don't clutter your panel—moreover, they're all *plug-in*. That means you don't need to fool with a screwdriver and wire-list to mount or remove a JMK. Just plug it into its prewired cable connector.

Kepco's JMK doesn't have hot radiator fins protruding in all directions—nor does it require elaborate derating for the elevated temperature of jammed systems racks. JMK has its own built-in blower system exhausting air (heated only about +15°) directly to its rear. You'll get *full output* from your JMK from -20°C to +71°C, no derating, no baking the equipment above.

JMK is fully programmable, you can control it with resistance, analog signals, or digital instruction with up to 12-bit resolution.* JMK, as an automatic crossover power supply, can be controlled in either mode with a degree of precision and stability that is close to standards-lab performance (5 ppm source effect, 50 ppm load effect, 50 ppm temperature effect coefficient. . .).

Kepco designed JMK for the systems man who needs a full-performance, programmable power supply to run his test program (on instructions from the computer) or a stable current source to energize sensitive circuits, or perhaps an ultra-stable voltage supply to which repeatable measurements can be referred.

Kepco's catalog contains the full specifications for the 14 JMK models ranging from 0-6 volts at 5 and 10 amperes to 0-100 volts at 0.5 and 1 ampere. Write to Dept. EK-14 for your free copy.

*Using a low-cost digital programming accessory.



KEPCO®

KEPCO, INC. • 131-38 SANFORD AVENUE • FLUSHING, N.Y. 11352 • (212) 461-7000 • TWX # 710-582-2631 • Cable: KEPCOPOWER NEWYORK

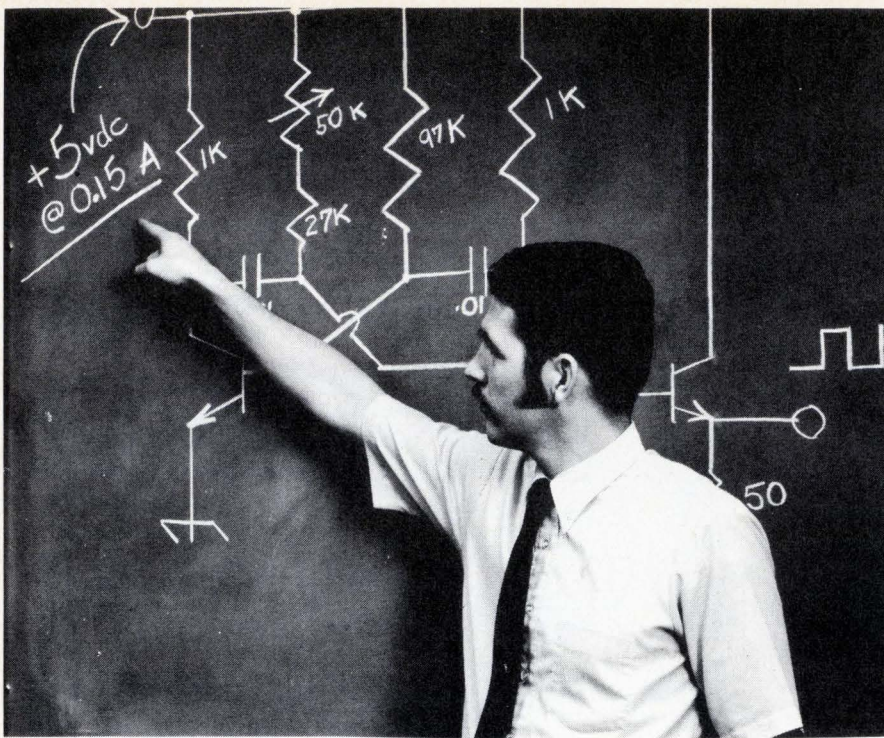

How to Design Your Power Supply for \$66

You get the **complete schematic diagram, and parts list** with operating and installation instructions when you spend \$66 for an Abbott Model "RN" power supply. Two years in development, this model represents the latest state of the art in power module design. It features close regulation (0.1%), low ripple (0.02%), automatic short circuit and complimentary overvoltage protection and continuous operation in a 160°F ambient.

Abbott Engineers followed specific design criteria in engineering these modules. First, the electrical design was carefully engineered to insure that all components operate well within their limits, under "worst case" operating conditions. Second, the thermal design, including case construction, was carefully made to insure that the maximum temperature limits of all components are never exceeded. Then the size and weight of these modules were controlled to a minimum, without sacrificing reliability. Finally these units were thoroughly tested to make certain that all design and performance specifications were met.

So, you can build your own power supply using our schematic diagram if you want to—but we think we can build it more

reliably and for less cost, simply because we have been doing it for ten years. Put our power supply in your system first and try it. Examine its performance. We think you will be pleasantly surprised at the quality, adherence to specifications, and the reliability you find in the Abbott Model "RN".

Any output voltage from 5 to 100 volts DC with current from 0.15 to 20 amperes is available. **Many of the popular voltages are carried in stock for immediate delivery.** Please call us for attractive O.E.M. discount prices.

Abbott also manufactures 3,000 other models of power supplies with output voltages from 5.0 to 3,650 volts DC and with output currents from 2 milliamperes to 20 amperes. They are all listed with prices in the new Abbott catalog with various inputs:

- 60 A to DC, Hermetically Sealed
- 400 A to DC, Regulated
- 28 VDC to DC, Regulated
- 28 VDC to 400 A, 1 ϕ or 3 ϕ
- 24 VDC to 60 A, 1 ϕ

Please see pages 581-593 of your 1973-74 EEM (ELECTRONIC ENGINEERS MASTER Catalog) for complete information on Abbott Modules.

Send for our new 56 page FREE catalog.

abbott transistor

LABORATORIES, INCORPORATED

general offices

eastern office

5200 W. Jefferson Blvd./Los Angeles 90016
(213) 936-8185 Telex: 69-1398

1224 Anderson Ave./Fort Lee, N.J. 07024
(201) 224-6900 Telex: 13-5332

Readers comment

Testing dynamic memories

To the Editor: In your recent article, "4,096-bit memories pose test woes," [*Electronics*, Dec. 20, 1973, p.65], I was indirectly quoted as saying that 4k makers won't be able to test the memories adequately. But what I really said was that if any form of n^2 test is found to isolate a sensitivity problem in a 4k memory, the maker would be forced to find alternative shorter test patterns to isolate it. Any n^2 pattern required would probably have to be performed by the user.

I believe that too much emphasis was placed on the thoroughness of Galpat as a pattern for testing dynamic memories. While Galpat is an extremely efficient pattern for static memories, it doesn't always seek out the sensitivity problems of dynamic memories. A better argument for it might be that the longer you exercise a memory, the more likely it is to fail. If you isolate the distinct exercise Galpat performs to detect a sensitivity problem, you could generate an alternative set of shorter patterns that could be exercised with a total execution time of $2n^{3/2}$, rather than $2n^2$, with generally the same results. Also, most failures are caused, not by what you do, but how many times you do it.

These exercises could be: all possible transitions between all the cells in a column, all possible transitions between all the cells in a row, and all possible transitions between each cell and all other cells in a different row and column. Proximity effects could be better tested by surround-bit-proximity tests.

The "march" pattern mentioned in your article constitutes the minimum pattern that can be exercised and still guarantee the functionality of each cell and the proper operation of the decoder circuitry.

In summary, a repertoire of patterns should be designed to test failure modes that are based on knowledge of the design. Other test patterns can be empirically developed as problems are uncovered in actual operating systems.

Philip Burlison
Macrodata Corp.
Sunnyvale, Calif.

A startling announcement:

TRW's new
Schottky Power
Rectifier

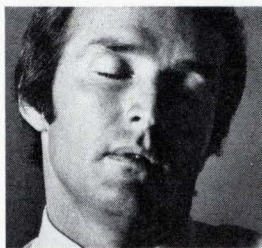

gives a
0.5V forward
voltage drop

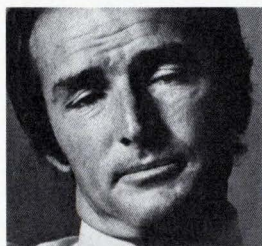

at 50 amps

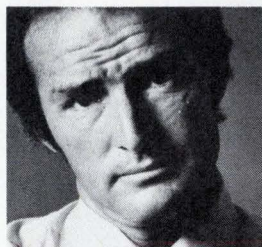

at a T_j of...125°C!

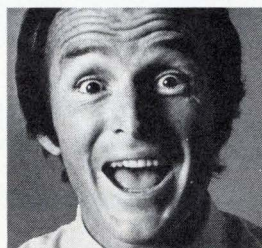

If that doesn't startle all power supply designers, nothing will.

Here's the first, and only, Schottky power rectifier that doesn't fssst-out at 100°C—let alone, higher! In fact, TRW's new device actually operates at a T_j of 125°C with a 0.5V_f at 50 amps.

Maybe you have heard discouraging talk about similar devices made by other companies. Or tried one, yourself. If so, you may have experienced "mysterious failures." Certainly you had

failure when T_j reached 100°C. And it was no mystery: the thing melted!

But this is different. This is made by TRW. After 5 years R&D to be sure it would work. And it does! At 100° At 125° With 35V reverse operating voltage.

Ask the nearest distributor for TRW's new Schottky power rectifier. Part number SD 51. Or contact John Powers, TRW Semiconductors, an Electronic Components Division of TRW, Inc., 14520 Aviation Boulevard, Lawndale, California 90260.

TRW® SEMICONDUCTORS

These products are available through the following authorized distributors:

Almo Electronics
Bell Industries
Cramer Electronics Inc.
De Mambro Electronics

Eastern Radio Corp.
Electronics Marketing Corp.
Elmar Electronics Inc.
Hall-Mark Electronics Corp.

Harvey-Michigan Inc.
Liberty Electronics
Powell Electronics
Pytronics

Semiconductor Concepts Inc.
Summit Distributor
R. V. Weatherford Co.
Westates Electronics Corp.

40 years ago

From the pages of Electronics, January 1934

Cathode ray television

From an engineering standpoint television is approaching a reality, brought into existence by technicians previously engaged in communication work in general, and in radio communication in particular. Television is communication, or the transmission of intelligence from one point to another. Webster's definition of intelligence is "information communicated," and one of the well-known mediums of communicating information is speech. The fastest speech is about 200 words a minute. It covers a frequency range up to 5,000 cycles at least, and for its transmission requires an air channel 10 kilocycles wide. For television transmission at about 24 frames or pictures a second, or 1440 per minute, the channel required is around two megacycles, or 200 times wider. This television channel then would accommodate 40,000 words a minute. In other words we transmit one picture or frame for the cost of 28 words of air space.

For a long time, many decades in fact, television has existed in principle at least and in facsimile transmission. But not until certain inherent limitations of disc scanning and reproducing were overcome did television become a reality. The old disc employed what could be called instantaneous scanning; the signal output was proportional to the time integral of light intensity over a very short period of time, during which the light from the picture element passed through the hole in the disc, and on to the photocell. Dr. Zworykin's iconoscope integrates the light intensity of a picture element over the time of an entire picture frame. A detailed description of this cathode ray principle of scanning has been presented to the Franklin Institute and will soon appear in their journal. The inverse of the iconoscope—the kinescope—has also been described and treated at length.

In broadcasting technique we deal purely with harmonic waves. These have always been of certain duration—a few cycles in most limiting cases.



Stacked...with beautiful curves!

(stacked-foil construction with ultra-low impedance, ultra-low ESR, ultra-low inductance)

Revolutionary new Type 432D COMPULYTIC® Aluminum Electrolytic Capacitors offer capacitance values to 100,000 μ F with equivalent series resistance of typically less than 0.001 ohm and inductance of only 1 nH in a 3" x 5 $\frac{5}{8}$ " case. This same capacitor will handle 93 amperes of ripple current at 65 C and 1 kHz.

Impedance limits at 10 kHz are as low as 0.001 ohm with typical values of only half of the specified limits.

Now available in two additional smaller case sizes for space-saving applications in smaller-wattage power supplies, with typical impedance of five milliohms.

For complete technical data, write for Engineering Bulletin 3443 to: Technical Literature Service, Sprague Electric Co., 35 Marshall St., North Adams, Mass. 01247.

Terminals are ideal for use with laminated-bus power distribution systems found in modern EDP equipment, where the low ESR and impedance of Compulytic capacitors help insure continued operation of logic circuits even during momentary power outages.

Sprague Type 432D Capacitors are available in nine voltage ratings from 5 to 50 volts d-c, and are designed for operation over the temperature range from -40 to +85 C.



THE BROAD-LINE PRODUCER OF ELECTRONIC PARTS

New options & accessories

Low ohms
2 and 20 Ω ,
0.001 Ω
resolution

High
current
10A cont.
20A
momentarily

Low
cost
RF
Probe

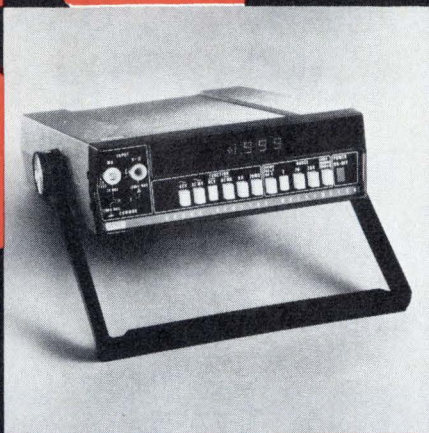

Recharge-
able
battery
pack

Deluxe
test
leads

High
voltage
probe,
1kV to 40kV

Clamp on
AC current
probe,
2 to 600A

Carrying
cases

Dust
cover

Digital
printer
output

Rack
mount
kits

Options and accessories already available

Fluke adds **MEASURE
POWER**

The best selling 3½ digit DMM. Now even better.

More new options & accessories. New AC/DC high current option lets you measure 10 Amps continuously or up to 20 Amps momentarily. New low ohms capability with 2 and 20 ohms full scale ranges provides maximum resolution of 0.001 ohms. New RF measurement capability available with low cost probe.

The Fluke 8000A Digital Multimeter brought a new standard of excellence and reliability to the low cost field. Today, with expanded capability, the 8000A brings that standard to even more of your measurement applications.

And don't forget what you get in the standard instrument.

With or without options and extras, the Fluke 8000A is the best digital multimeter for the money. You get a basic

dc accuracy of 0.1%. You get 26 ranges to measure ac/dc volts from 100 microvolts to 1200 volts, current from 100 nanoamperes to 2 amperes and resistance from 100 milliohms to 20 megohms.

We back the instrument with a guaranteed 20,000 hour Mean Time Between Failures. We expect you'll get 56,000 hours service . . . roughly the equivalent of 15 years everyday use.

Or the options already offered.

The option list includes in addition to those described above, a rechargeable battery pack, digital printer output, deluxe test leads, 40 kV high voltage probe, 600 ampere ac current probe, two types of carrying cases, dust cover and rack mounts.

For data out today, dial our toll-free hotline, 800-426-0361

In the continental U.S., dial our toll free number 800-426-0361 for the name and address of your nearest local source. Abroad and in Canada, call or write the office nearest you listed below, John Fluke Mfg. Co., Inc., P.O. Box 7428, Seattle, Washington 98133. Phone (206) 774-2211. TWX: 910-449-2850. In Europe, address Fluke Nederland (B.V.), P.O. Box 5053, Tilburg, The Netherlands. Phone 013-67-3973. Telex: 844-52237. In the U.K., address Fluke International Corp., Garnett Close, Watford, WD2 4TT. Phone, Watford, 33066. Telex: 934583. In Canada, address ACA, Ltd., 6427 Northam Drive, Mississauga, Ontario. Phone 416-678-1500. TWX: 610-492-2119.

FLUKE®

Circle 9 on reader service card

AMD-approved MOS parts aren't your ordinary run-of-the-mill second-source devices. We start by picking the most popular designs on the market. Then — because we just can't leave well enough alone — we make them better.

**Before you buy any MOS parts,
be sure they're AMD-approved.**

When you're shopping for MOS, take our list along. It shows our versions of more than 20 of the most popular MOS devices on the market. Every one is built to MIL-STD-883 at no extra charge. Every spec is guaranteed to be as good — or better — than the original. Every part is available for immediate delivery.

Yes, we're in MOS for keeps. And we've gotten so good at making other people's designs better, we've become the preferred source. If you want spec sheets or app notes, call or write and we'll rush them to you.

Official AMD-Approved MOS Parts List

(as of January 1, 1974.)

Am1002	Dual 128-Bit Static Shift Register	Am2512	1024-Bit Dynamic Recirculating Shift Register
Am1101A	256-Bit Random Access Memory	Am3341	64 x 4-Bit FIFO Memory
Am1101A1	256-Bit Random Access Memory		
Am1402A	Quad 256-Bit Dynamic Shift Register		For improved performance, use:
Am1403A	Dual 512-Bit Dynamic Shift Register	Am2802	10 MHz Quad 256-Bit Dynamic Shift Register
Am1404A	Single 1024-Bit Dynamic Shift Register	Am2803	10 MHz Dual 512-Bit Dynamic Shift Register
Am1405A	512-Bit Dynamic Recirculating Shift Register	Am2804	10 MHz Single 1024-Bit Dynamic Shift Register
Am1406/1506	Dual 100-Bit Dynamic Shift Register	Am2805	512-Bit Dynamic Recirculating Shift Register
Am1407/1507	Dual 100-Bit Dynamic Shift Register	Am2806	1024-Bit Dynamic Recirculating Shift Register
Am2505	512-Bit Dynamic Recirculating Shift Register	Am2810	Dual 128-Bit Static Shift Register
		Am2841	64 x 4-Bit FIFO Memory

(To be continued...)

AMD MOS: One more reason why we're going to be the sixth largest maker of integrated circuits in the United States by 1975.

Advanced Micro Devices, Inc.

(#15, going on #6.)

Advanced Micro Devices, Inc. 901 Thompson Place, Sunnyvale, California 94086 / TWX 910-339-9280 / TLX 346306.

For product or sales information, call the AMD sales representative nearest you. In Sunnyvale, Bill Seifert at (800) 538-7904 (toll-free from outside California) or (408) 732-2400. In Upstate New York, Tom Sapere at (315) 463-8592. In the eastern United States, Steve Marks or Jack Maynard at (516) 484-4990; in Washington/Baltimore, Ken Smyth at (301) 744-8233; in Boston, Paul Macdonald at (617) 861-0606. In Mid-America, Chuck Keough at (312) 297-4115. In the Los Angeles area, Steve Zelencik or Russ Almand at (213) 278-9700. In the Northwest, Shel Schumaker at (408) 732-2400. In the United Kingdom, Des Candy at Herne Bay (Kent) 61611.

And in Germany, Hermann Lichotka at (0811) 594-680.

Advanced Micro Devices is distributed nationally by Cramer and Hamilton / Avnet Electronics.

• **Independent control of pulse high and low levels**

• **Pulse amplitude to 5 volts**

• **Output window +5 V to -5 V**

• **Less than 1 ns risetime**

• **250 MHz rep rate**

The Tektronix PG 502 Pulse Generator is a high performance instrument ideal for designing, testing, or maintaining the logic circuitry in high-speed digital computers, and similar applications. It is a general purpose signal source with rise and fall times less than 1 ns. Both the pulse duration and period of the PG 502 output can be controlled and independent control of the pulse high and low levels is offered. The trigger circuit includes external trigger input, manual triggers, and pre-trigger output.

Tektronix offers a range of signal sources in addition to the PG 502.

FG 501 Function generator; 0.001 Hz to 1 MHz, five waveforms \$ 325

FG 502 Function generator; 0.1 Hz to 11 MHz, 25 ns rise and fall, five waveforms \$ 425

PG 501 Pulse generator; 5 Hz to 50 MHz, 3.5 ns rise and fall \$ 295

PG 502 Pulse generator; 250 MHz, 1 ns rise and fall, independently controllable logic 1 and 0 levels \$ 995

PG 505 Pulse generator; 100 kHz, 80 V floating output, independently variable rise and fall times \$ 265

RG 501 Ramp generator; 10- μ s-to-10-s ramp, with four scope type trigger controls . . \$ 175

Signal Sources: Another way to think of Tektronix

SG 502 RC oscillator; 5 Hz to 500 kHz, sine and square-waves, 0.1% distortion \$ 295

SG 503 Sinewave oscillator; regulated, constant-amplitude variable from 250 kHz to 250 MHz \$ 600

TG 501 Time-mark generator; 1-ns-to-5-s markers, measures timing errors with resolution within 0.1% over timing-error range of 7.5% \$ 650

Signal sources are just one category of instruments in the Tektronix TM 500 Series. Presently, 24 general purpose modular test and measurement instruments are available including digital counters, digital multimeters, power supplies, signal processors, and CRT

monitors. These interchangeable instruments plug into power units with single (\$115) or triple (\$150) compartments. In the triple compartment power unit, the modules can be interconnected via a common interface board and optional rear panel connectors. This results in increased intermodule capabilities and can actually produce a synergistic effect. The modularity feature also saves bench space. The TM 500 Series is based on the latest technology and proven principles developed in building oscilloscopes.

Send for a free brochure and spec sheets on signal sources, and Tektronix other TM 500 test and measurement instruments. They're all new ways to think of Tektronix!

Write: Tektronix, Inc.
P. O. Box 500
Beaverton, Oregon 97005
In Europe write:
Tektronix Ltd.
P.O. Box 36
St. Peter Port, Guernsey, C.I., U.K.



Digital Multimeter
Price, \$395

Pulse Generator
Price, \$995

Counter
Price, \$1,195

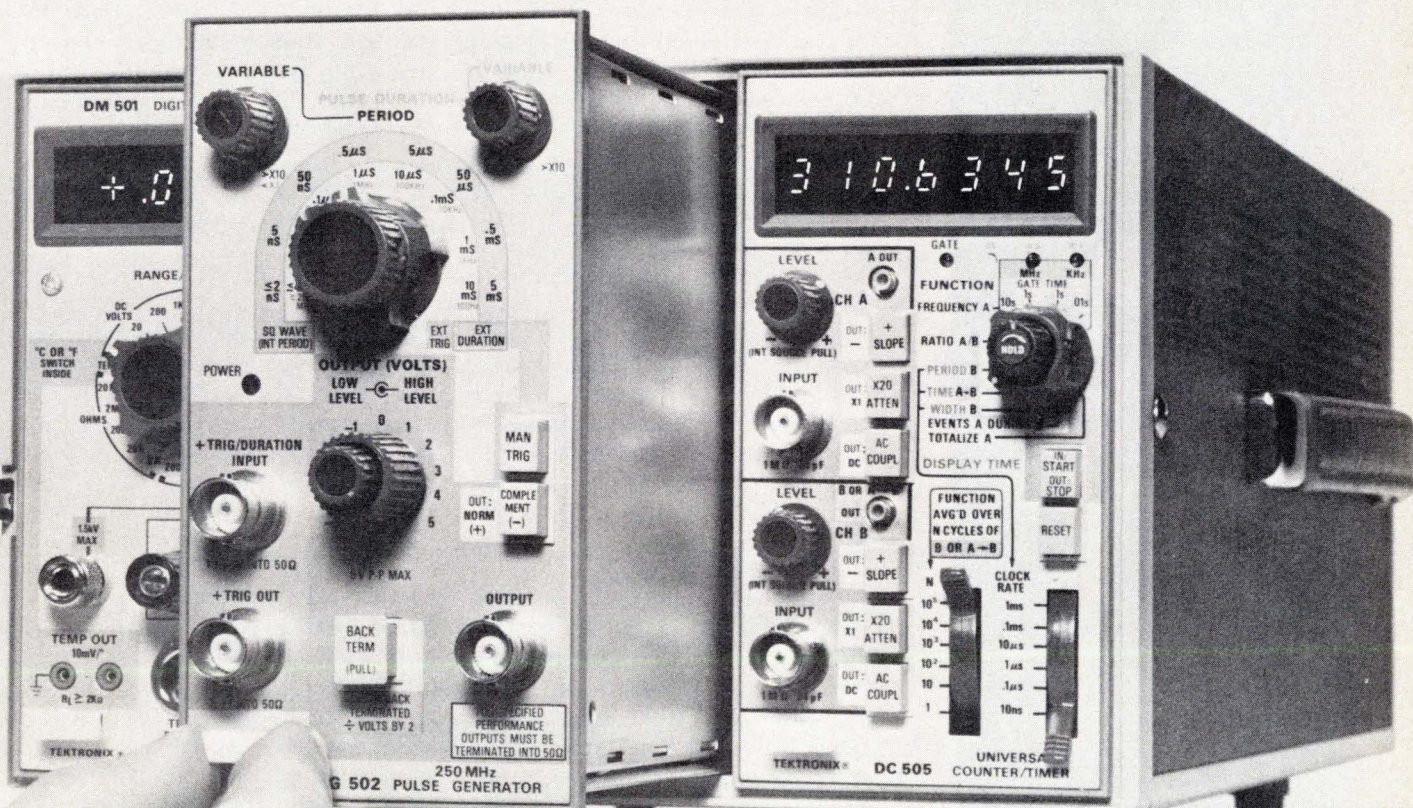

For a demonstration circle 12 on reader service card

Circle 13 on reader service card

RCL

SWITCH ENGINEERING HANDBOOK



AN EASY-TO-READ
NEWLY EXPANDED
TECHNICAL CATALOG OF
INDUSTRY'S MOST
COMPLETE SELECTION
OF

MINIATURE ROTARY SWITCHES

INCLUDING MILLIMETER
CONVERSION DRAWINGS OF
EVERY RCL SWITCH!

RCL

General Sales Office
RCL ELECTRONICS, INC.
700 South 21st Street
Irvington, New Jersey 07111

People

Simpson foresees TV safety standards

"I'll tell you what one commissioner thinks—myself. There will be Federal standards for shock and fire," declares Richard O. Simpson, chairman of the Consumer Products Safety Commission (CPSC). Simpson indicates that he expects other commissioners to concur in mandating TV safety regulations [see p. 70]. He says that standards are needed because commission data suggests that TV sets are causing too many injuries, and in some cases, deaths, by fire and shock.

But, "industry has no need to be afraid of us," the 43-year-old electronics engineer says, because "our investigation arose out of an obvious problem"—a sentiment not likely to assuage industry anxiety. By this, Simpson means that safety data supplied by set makers, as required by law, shows "well over 100,000 different sets with defects in them such as to cause a substantial product hazard" since the commission began operations last May. He adds, though, that the same law requires manufacturers and other interested parties to have a close hand in the writing of any new regulations, should the commission, as it appears likely, decide to do so.

The TV-safety probe is one of many that the cigar-smoking chairman will head in the months to come, a direction that will make the body increasingly controversial in some industries. But Simpson, who says he's worked long hours all his career, seems to relish his role. Simpson seems intent on running a very independent regulatory agency. He already has had public scrapes with the White House Office of Manage-

ment and Budget over whether or not he should disclose his budget negotiations with that office.

Before he became chairman last May, Simpson was acting Assistant Secretary of Commerce for Science and Technology. He made the switch "principally because I was asked," he says. "It's a presidential nomination." Prior to joining the

Commerce Department in 1969, he was a group vice president with the Rucker Co., Oakland, Calif., and had operated his own engineering firm in San Francisco. Born in Independence, Mo., he received his electrical engineering degree from the University of California at Berkeley,



Home safe. CPSC chief Simpson says his group will mandate TV-safety rules.

ledley, studied law there, and did graduate work at Stanford University while working with Sylvania's Electronics Defense Laboratory on electronic-countermeasures gear.

Ledley builds new medical electronics

Having developed a digitally enhanced X-ray scanner that gives sharp color cross-sectional views of the body [*Electronics*, Oct. 25, p. 32], Robert S. Ledley of Georgetown University Medical Center is busy these days getting it installed. What's more, good as the scanner appears to be, he's already thinking about improvements—a complete set of scans can take up to 5 minutes, so "you don't get a great picture of the heart and lungs," he observes. But Ledley believes he can use the scanner principle to create an instrument that can let doctors better monitor a patient's moving heart and lungs.

Professor of physiology and biophysics at the center and presi-

Don't overdraw. Use these Kodak shortcuts:

The snappy restoration shortcut.

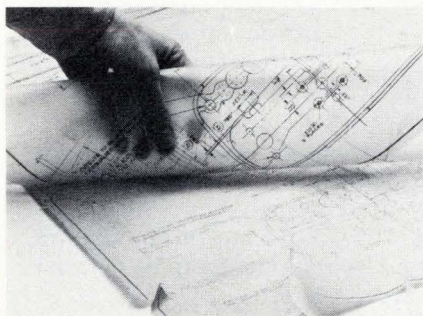

Why waste time retracing your old, battered drawings? Restore them by making sharp, clean photographic reproductions on Kodagraph film. Weak lines come back strong and clear. Stains virtually disappear. And instead of gray lines on yellow, you'll have snappy, contrasty, black-on-white prints.

The drop-of-water shortcut.

Why retrace the whole design for a few revisions? Just

order a second original on Kodagraph wash-off film. Then use a drop of water and erase unwanted details.

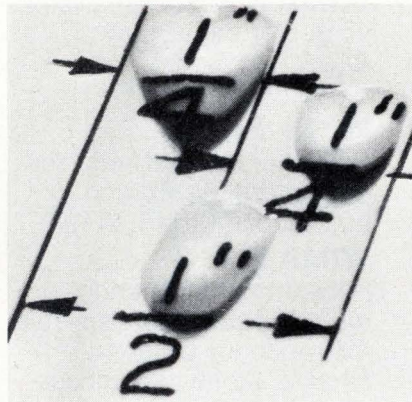

Draw your design revisions on the film and you're done.

The multiplication shortcut.

Why draw the same detail over and over? Kodagraph film will do the job for you. That way you draw the detail just once. Make as many photoreproductions as you need. Cut them out, paste them down, and make a

Kodagraph film print of the paste-up.

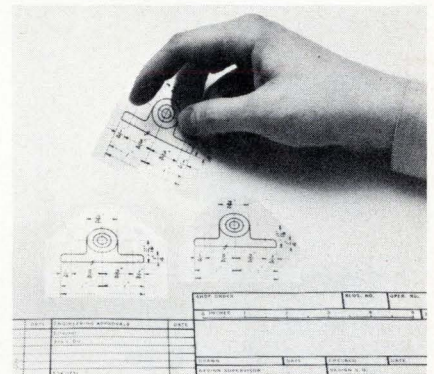

Now you have a superb second original for subsequent printmaking.

Get the facts from Kodak.

Drop us a line for more facts on how you can reduce drafting time and save money too, with Kodagraph films and papers. Eastman Kodak Company, Business Systems Markets Division, Dept. DP531, Rochester, N.Y. 14650.

Kodak products for engineering data systems.



Cast moulded WIMA® capacitors



**Encapsulated
in cast resin under
vacuum to eliminate
air inclusions.**

**Advantages:
Small physical size;
high resistance to
moisture, favourable
a. c. characteristics.
Voltage ratings
up to 1000 V d. c.**

**For stringent
requirements.**

Types:

WIMA MKS 3 Metallized polyester capacitors for 100 and 250 V d. c. 0.022 μ F ... 0.47 μ F.

WIMA FKS 3 Polyester film and metal foil capacitors for 160 and 400 V d.c. 1000 pF ... 0.1 μ F.

WIMA FKC 3 Polycarbonate film and metal foil capacitors suitable for frequency divider circuits. Close tolerances available. 160, 400, 630 and 1000 V d. c. 100 pF ... 0.1 μ F.

WIMA FKS 2 min. Polyester film and metal foil capacitors, subminiature, suitable for very small equipment. 100 V d. c. from 100 pF ... 0.047 μ F.

WILHELM WESTERMANN

Spezialfabrik
für Kondensatoren
Augusta-Anlage 56
P.O. Box 2345
D-68 Mannheim 1
Fed. Rep. of Germany
Tel.: (621) 40 8012

*Please send for
our latest
catalogue.*



People

dent of the affiliated not-for-profit National Biomedical Research Foundation, Ledley heads a 20-person shop devoted to developing medical electronics devices like these. Another current interest is computerizing thermographic machines which would give doctors objective measurements for two immediate applications, early detection of breast cancer and incipient stroke. "In dermatology, this would be even more important" as a means to spot skin cancer, he adds.

Computer-aided. In more general terms, Ledley would like to get into computer-aided diagnosis and prognosis. In fact, a fundamental part of his work has been in computerized pattern-recognition techniques. His group built the first flying-spot scanning microscope, he says, and has produced an automated chromosome analyzer and a computer-controlled microscope, which are sold through a "very small company" he also runs. Dividing pattern-recognition into the three phases of feature extraction, classification, and clinical trials, Ledley says "we're a third of the way there" in 12 different applications, including moving-picture X-rays of the heart, measuring the volume of the lung in detail, pap-smear analysis, and electron-micrographic analysis of nerve synapses.

To the common complaint that there aren't renaissance men around in this technologically specialized aged, one might consider the 47-year-old electronics researcher's career, which reflects his many interests. While attending both New York University College of Dentistry and Columbia University, he earned a doctorate of dentistry and an M.A. in mathematics.

He conducted pioneering work on digital computers while associated with the National Bureau of Standards. Later, as a professor of electrical engineering at George Washington University, Ledley says he gave the first graduate and undergraduate courses on digital computers and programing. And he has also written several books about computers.

The go-anywhere, do-anything, easy-on-the-budget signal source



Exact announces a new low-cost, fully portable function generator

Here's the perfect companion for your portable multimeter or oscilloscope. Exact's new Model 191 AC/DC Function Generator is equally at home on the bench, in the field operating on its own rechargeable batteries or plugged into your car's cigarette lighter.

Toss this rugged little signal source into your briefcase. Its light weight and small size make it the first truly portable function generator. It has a high-impact plastic case, and weighs just 4 pounds, including battery pack.

At a surprisingly low cost, the Model 191 and its companion AC Model 190 give you a full range of signal capability, including sine, square, triangle, pulse and ramp waveforms, VCF input, DC offset and TTL pulse output. Frequencies from 0.1 Hz to 1 MHz cover most of your signal requirements.

check these features

OUTPUT: Sine, square, triangle, ramp and pulse, > 20V pp open circuit, > 10V pp into 600 ohms.

TTL PULSE OUTPUT: TTL compatible, < 25 ns risetime, will sink 20 TTL loads.

SINE FREQUENCY RESPONSE: < 0.1 db to 100 kHz, < .5 db 100 kHz to 1 MHz.

SINE WAVE DISTORTION: Typically 0.5%.

SQUARE WAVEFORM: Rise and fall time < 100 ns.

VCF INPUT (Voltage Controlled Frequency): Accepts d-c to wideband ac frequency modulation; approx 5V input for 1000:1 (three decades) frequency control.

DC OFFSET: Variable $\pm 10V$.

VARIABLE TIME SYMMETRY: For ramp and pulse operation.

SIZE: 7 $\frac{3}{8}$ " wide x 2 $\frac{7}{8}$ " high x 8 $\frac{1}{2}$ " deep.

Model 190 (AC) \$245

Model 191 (AC/DC) \$350 complete with rechargeable battery pack and charger. f.o.b. Hillsboro, Oregon

 **EXACT**
electronics, inc.

(A Subsidiary of Danalab, Inc.)
BOX 160, HILLSBORO, OREGON 97123
(503) 648-6661 TWX 910-460-8811

A better answer.

TI's unique modular building block construction permits custom configurations at minimal cost.

Standard .150 inches travel with 2.0 ounces actuating force. Also available with .100 inches travel and lower profile.

High quality double shot molded thermoplastic keytops available in many colors. Or you can buy keyboards alone.

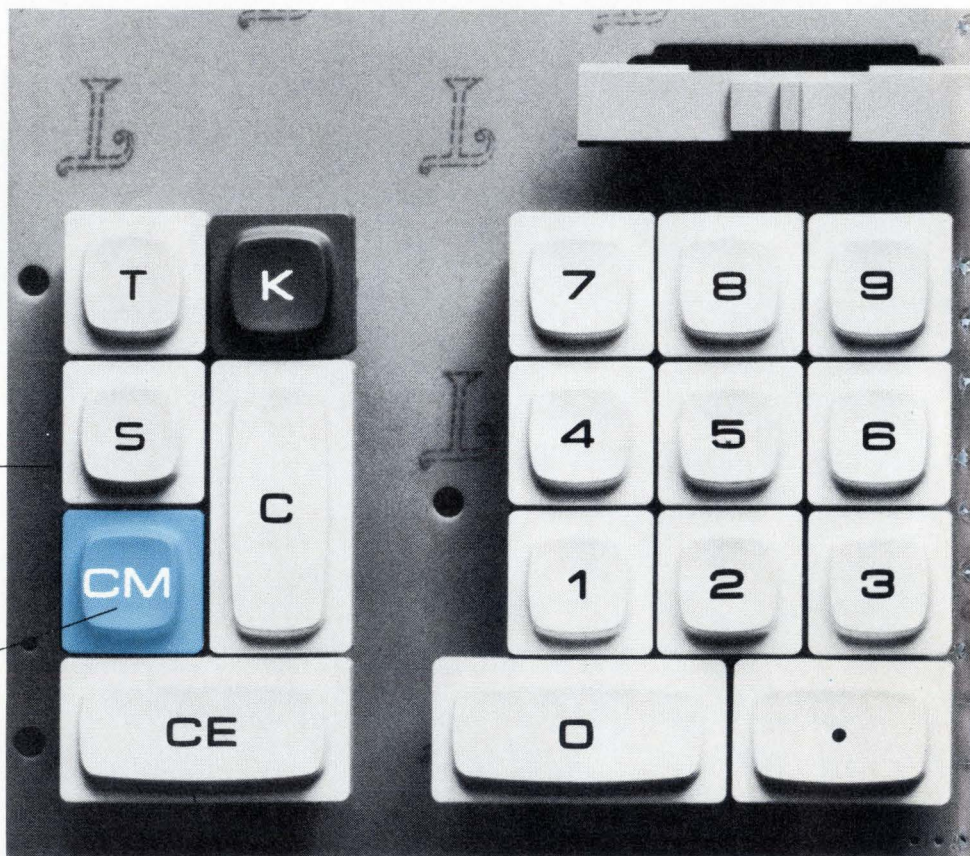

Keyswitch materials and a high length-over-diameter ratio provide the smooth, quality feel necessary for professional users.

Fully assembled on a circuit board to reduce your assembly costs.

The new 5KS desktop keyboard from Texas Instruments, the world's leading supplier of pocket calculator keyboards. A new money-saving modular keyboard system provides the design flexibility desktop calculator manufacturers need for quick and inexpensive model changes.

Before Texas Instruments modular keyboard systems, you could get keyboards for desktop calculators two ways. First you could buy individual keyswitches or keyswitch rows and assemble them yourself. (This assembly, which includes mounting on PC boards, soldering and testing, adds at least 25% to the price of the keyswitch alone.) Secondly, you could buy a custom molded assembly which requires a high tooling charge.

Now the people who brought you the pocket calculator keyboard bring you the best of two worlds. The first complete travel keyboard that gives you economy and flexibility using a unique modular keyboard system.

The keyswitches consist of only four parts for simple trouble-free operation and low cost. The keyboard assembly is a series of keyswitch clusters that can be arranged on a printed circuit board in any desired layout. Using TI's established library of available cluster modules, calculator manufacturers can change models with only a low cost circuit board revision.

This is the new 5KS from TI, a dependable low cost keyboard for desktop calculators, credit card verifiers, point-of-sale terminals, and other equipment where a keyboard is required. For more information, fill in the coupon.

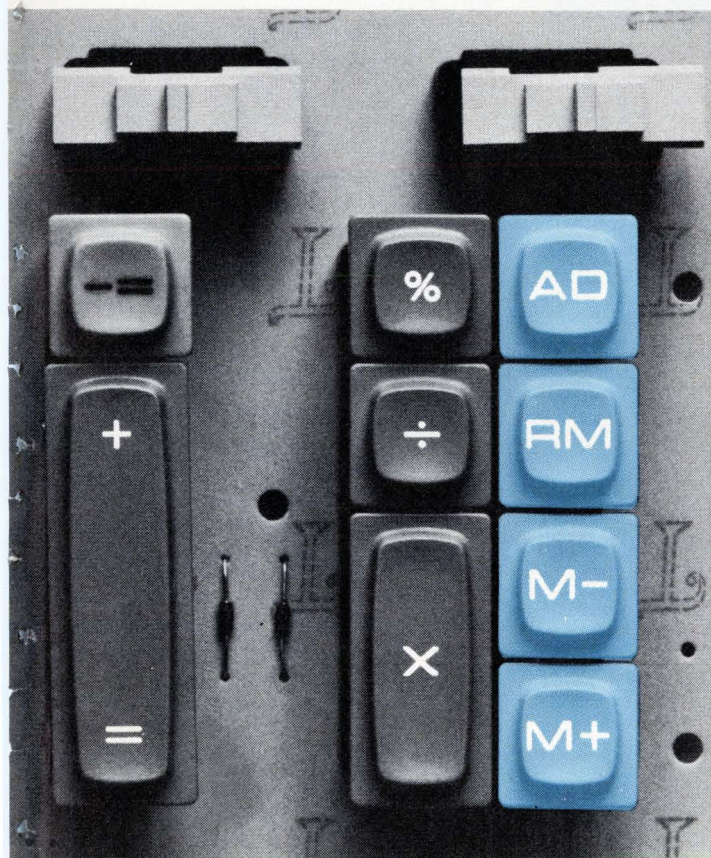

Actual size.

Texas Instruments Incorporated
Keyboard Products Marketing
MS 12-33/DE
Attleboro, Mass. 02703

Name _____

Title _____

Company _____

Address _____

City _____

State _____ Zip _____

Keyboard application:

- Desk-top Calculator Pocket Calculator
 Point of Sale Terminal Credit Card Verifier

Other _____

Application is new or existing

Approximate annual usage _____ units

Please have a TI Field Engineer call

TEXAS INSTRUMENTS
INCORPORATED

Putting new technologies at your fingertips.

NEW
FROM
AIRPAX



The New Design

Edge-reading Control Meter the ER-35

The solid state AIRPAX "Parkermeter"® Series ER 35 Control Meter... the finest ultra-compact, contactless, edge-reading meter available today... improved switching... more reliable meter movement... extremely rugged precision-molded case... state-of-the-art manufacturing throughout. The ER-35 is available with one or two set points and provides four control switching configurations... is only 7/8" thick... can be panel mounted or stacked in any quantity as required... horizontal or vertical displays available. Truly the most modern and dependable of all.

For detailed information write for Catalog 0200G.

AIRPAX Controls Division P.O. Box 8488
Fort Lauderdale, Florida 33310 Phone: 305/587-1100

AIRPAX™

Meetings

Reliability and Maintainability Symposium: IEEE, Biltmore, Los Angeles, Calif., Jan. 29-31.

International Solid State Circuits Conference: IEEE, University of Pennsylvania, Marriott Hotel, Philadelphia, Feb. 13-15.

Computer Conference (Comcon): IEEE, Jack Tarr Hotel, San Francisco, Feb. 26-28.

Aerospace and Electronics Systems Winter Convention (Wincon): IEEE, Marriott Hotel, Los Angeles, March 12-14.

Zurich Digital Communications International Seminar: IEEE, Swiss Federal Institute of Technology, Zurich, Switzerland, March 12-15.

International Convention (Intercon): IEEE, Coliseum and Statler Hilton Hotel, New York, March 26-29.

International Reliability Physics Symposium: IEEE, MGM Grand Hotel, Las Vegas, Nev., April 2-4.

International Optical Computing Conference. IEEE Computer Society, Zurich, Switzerland, April 9-11.

Optical and Acoustical Micro-Electronics: IEEE, Commodore Hotel, New York, N.Y., April 16-18.

Carnahan Conference on Electronic Crime Countermeasures: IEEE, Univ. of Kentucky, Lexington, April 17-19.

International Circuits and Systems Symposium: IEEE, Sir Francis Drake Hotel, San Francisco, April 21-24.

Communications Satellite Systems Conference: IEEE, International Hotel, Los Angeles, Calif., April 22-24.

Pittsburgh Conference on Modeling and Simulation: ISA, University of Pittsburgh, Pa., April 24-26.

National Computer Conference: AFIPS, IEEE Computer Society, McCormick Place, Chicago, Ill., May 6-10.

**We have a half
million ways to
solve your card
packaging problems...**

**We
do it
better**

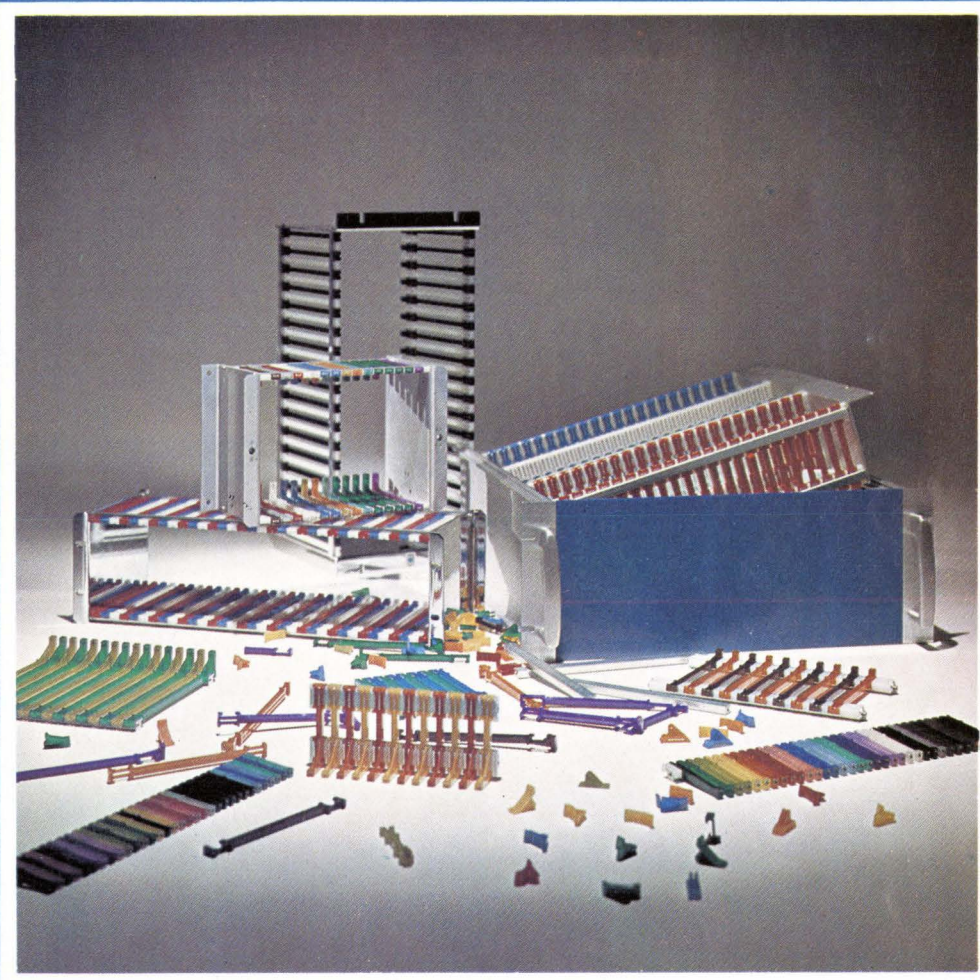

Configurations are virtually unlimited . . . bulk components, subassemblies, files, kits, drawers—horizontal or vertical.

We do it by offering nylon guides with integral connector mounting feet. This insures precise card/connector alignment while permitting complete card length and spacing flexibility.

We do it with guides that snap-on to strong extruded aluminum bars between end plates or drawer frames. This provides an exceptionally rugged, lightweight package perfectly suited to your particular card file needs . . . when it's put together, it stays together.

We do it by mounting mother boards and back planes in single or multiple row files. We do it by

mounting large or small cards with any connector arrangement.

We do it by really solving packaging problems . . . yours, his and theirs. So give Scanbe a call or send us your requirements. Either way, we can help you do it better.

Scanbe Manufacturing Corporation
3445 Fletcher Avenue
El Monte, California 91731
(213) 579-2300/686-1202 TWX: 910-587-3437

 **SCANBE**
CANOGA INDUSTRIES

Circle 21 on reader service card

More ideas from Amphenol's

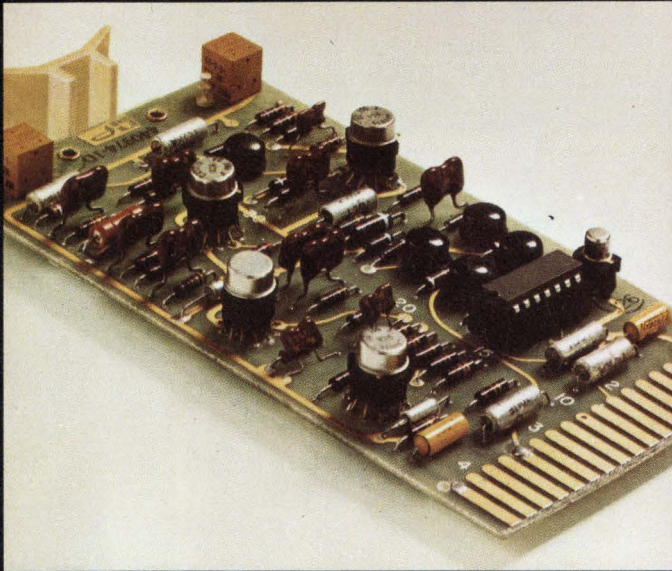

level 1 Low-cost sockets for transistors in TO packages (above) allow easy replacement and service. ■ New IC sockets are end and side stackable for maximum single board density. Low profile design also allows maximum multi-board density.

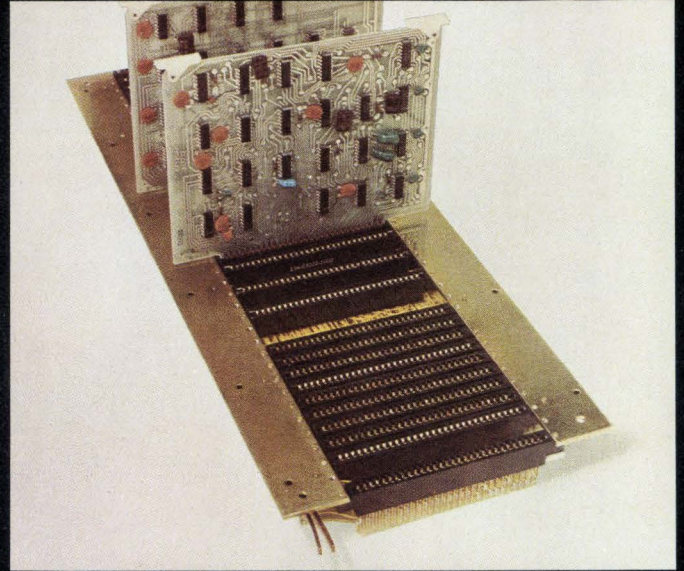

level 2 Back panel edge board connectors with bifurcated contacts (above) can be wire wrapped or clip-terminated. ■ Bellows contact PC connectors (below) cut interconnection costs without sacrificing performance.

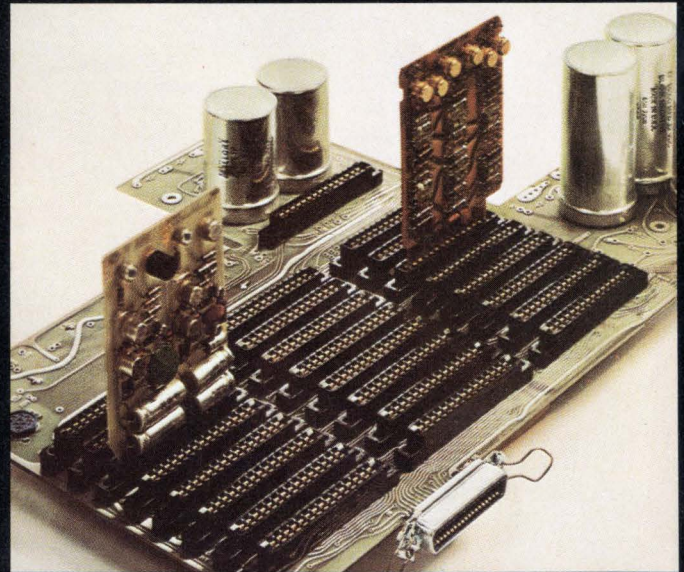
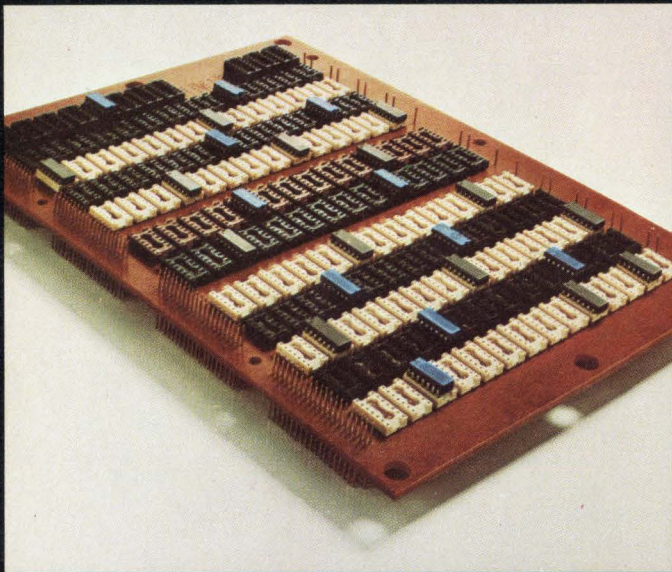

Above are seven new ideas from Amphenol Industrial Division's Spectrum of interconnection capability.

Amphenol's SPECTRUM offers you *all four* levels of interconnections from our unmatched breadth of product line:

Level 1 . . . DEVICE TO BOARD OR CHASSIS. We offer interconnections for components such as tubes, relays, transistors, IC packages, trimmers, resistors or capacitors to a PC board or chassis.

Level 2 . . . BOARD TO MOTHERBOARD OR BACK PLANE. We offer interconnections for PC boards or

other sub-circuit modules to a motherboard or to a back plane.

Level 3 . . . MOTHERBOARD OR BACK PLANE WIRING. We offer interconnections for levels to each other and to other sub-circuits with multi-layer circuit boards, wire wrapping, clip terminations, jumper techniques and dip-soldering.

Level 4 . . . INPUT/OUTPUT CONNECTIONS. We offer interconnections for power and signals to and from a system. This interface may be between sub-assemblies within the same enclosure or between individual units.

Spectrum of interconnections.

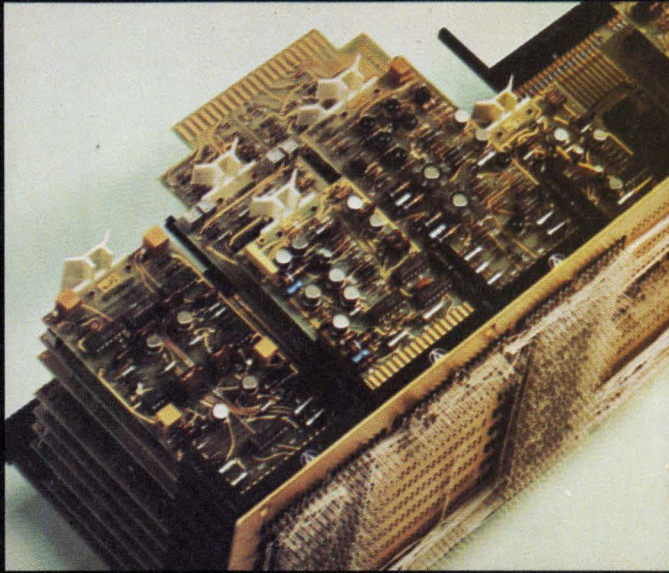

level **3**

Direct entry plate assembly offers modular packaging flexibility. Custom designed plates accommodate any size or style PC board with no tooling cost to you. Rectangular posts are true positioned for automatic wire-wrapping.

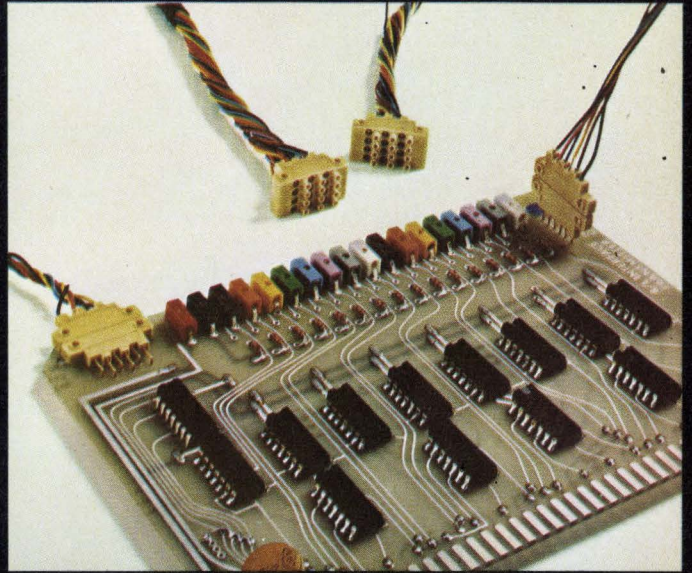

level **4**

Miniature contact (3 input, 3 output) hermaphroditic connectors can be snapped together to connect as many circuits as required. ■ Single finger-tip mounting of low cost connector saves assembly time. Available in UL Class SE-1 flammability rated material.

Write for our Spectrum brochure covering all levels of interconnections.

Spectrum
OF INTERCONNECTION CAPABILITY

AMPHENOL
INDUSTRIAL DIVISION

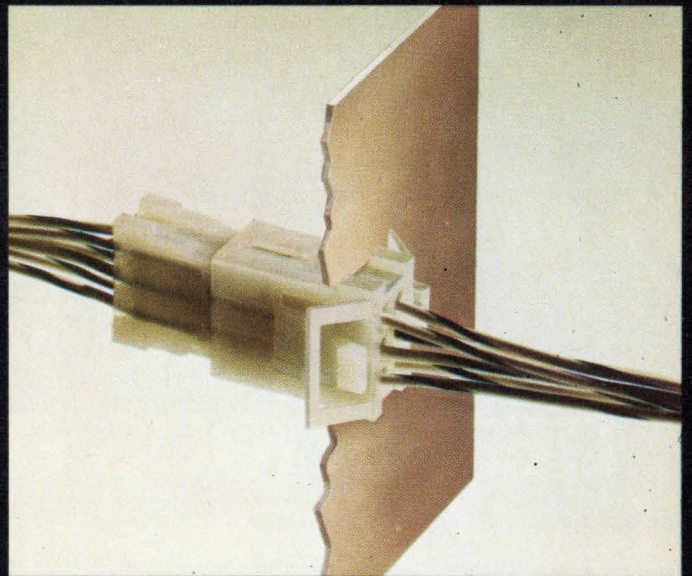

From the simple tube socket—to a myriad of electrical/electronic connectors—to complete and complex termination systems . . . SPECTRUM.

But SPECTRUM is far more than products. It is a depth of capability in engineering, manufacturing and quality control. Amphenol's SPECTRUM is a new height of service, availability and distribution backed by seven Amphenol interconnection-oriented divisions.

Amphenol can fulfill your total interconnection requirements because we are not limited to specifics such as one or two product lines, one or two levels.

Therefore we approach your interconnection needs with complete open-mindedness.

For more new ideas and specific information, write for your copy of "SPECTRUM." Amphenol Industrial Division, Bunker Ramo Corp., 1830 South 54th Ave., Chicago, Illinois 60650.

BUNKER RAMO **AMPHENOL**

Circle 23 on reader service card

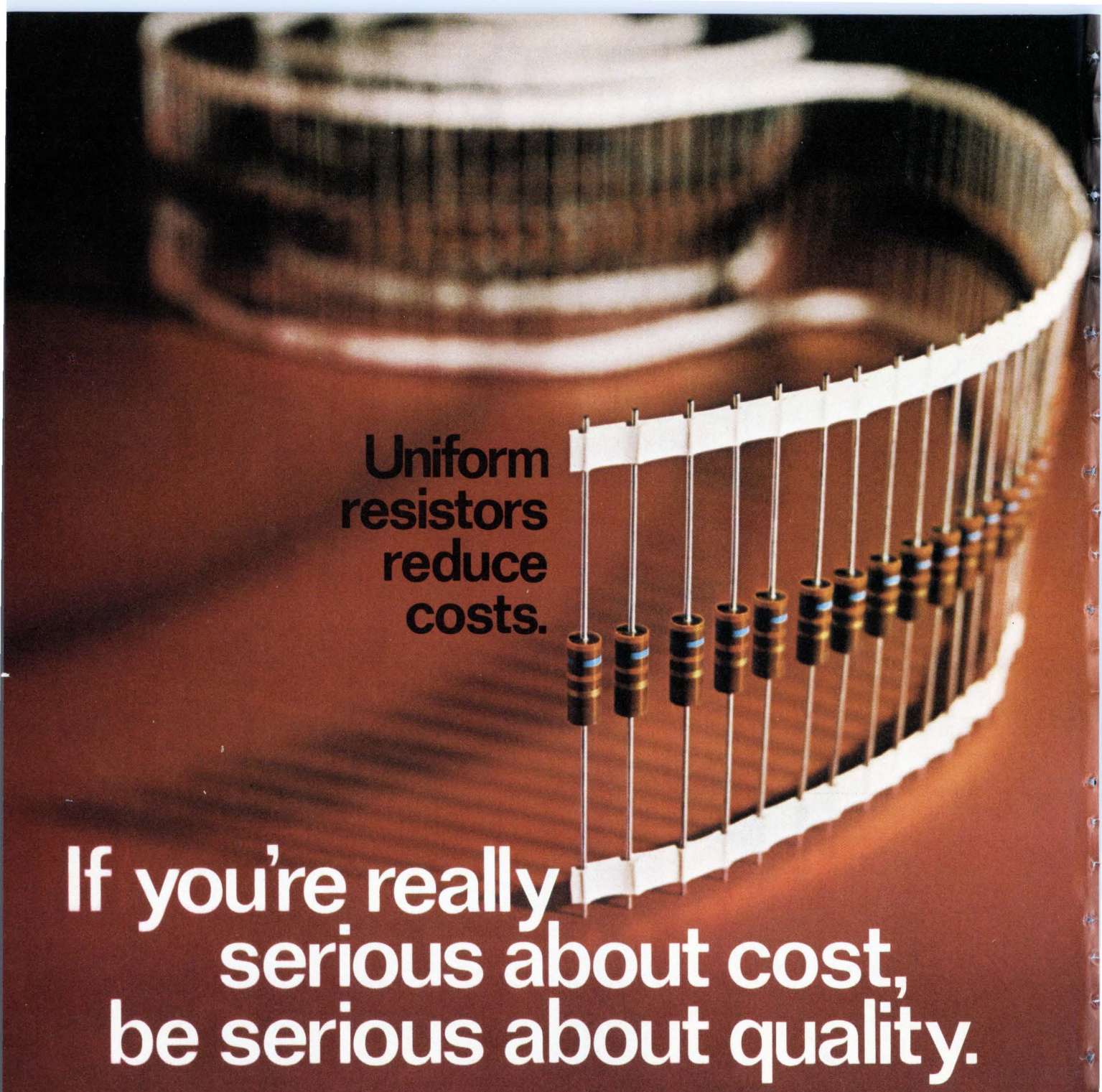

**Uniform
resistors
reduce
costs.**

**If you're really
serious about cost,
be serious about quality.**

That could be money in your pocket. Allen-Bradley's exclusive hot molding process offers physical consistency that can reduce your installation costs. Bodies are a uniform size with clean squared ends, free from coatings which adversely affect automatic handling equipment. Lead

lengths and diameters are precise. Resistors with uniform physical characteristics, accurately placed on tape reels, eliminate insertion machine jam-ups. And trouble free assembly means less production down-time; lower cost. That's A-B quality. Consistent shipment after shipment. If you

think all resistors are the same, send for our free booklet, "7 ways to tell the difference in fixed resistors." Allen-Bradley Electronics Div., 1201 S. 2nd St., Milwaukee, WI 53204. Export: Bloomfield, NJ 07003. Canada: Allen-Bradley Canada Ltd., Cambridge, Ont. U. K.: Jarrow, Co. Durham NE32 3EN.

EC80



ALLEN-BRADLEY

Milwaukee, Wisconsin 53204

Current variation changes LED from red to green

Light-emitting diodes of gallium phosphide can be made to emit in red, green, or yellow, depending on how the material is doped. But now the R&D division of Bowmar Canada has developed **a single LED device that can vary colors—red or green—depending on the amount of current used to drive the device.**

In the Bowmar LED, developed under a contract from NASA in Langley, Va., compatible emission efficiencies for the red and green components are 1% to 2% for the red and 0.1% to 0.2% for the green. But, since the eye is about an order of magnitude more sensitive to the green emission band, **similar brightness levels are perceived, whether displayed in the red or the green mode.** NASA has given the company a further contract to extend its variable-color LED technology to large-scale multicolor arrays.

Advanced methods used to build optical components

The highly sophisticated techniques used to obtain tight geometries in microelectronic devices **show promise of opening up the optical component field** (see p. 34). Researchers at Hughes Research Laboratories in Malibu, Calif., have described at the recent integrated optics meeting their use of ion-beam etching, rf plasma sputtering, and scanning-electron-beam pattern generation to make such optical components as waveguides, couplers, polarizers, and sampling gratings. The parts require spacings of 0.2 micrometer, about 10 times the resolution necessary in microelectronics, **and this cannot be accomplished with conventional photolithography and chemical etching.**

The parts are components, rather than integrated optical systems, and Hugh L. Garvin, a Hughes spokesman, reports that applications in true integrated systems are still in the future. But he says that some devices, notably a wire-grid polarizer and a sampling grating, are already finding their way into military communications systems. The optical components and integrated systems have great potential because of their very wide bandwidth.

Displays ride on voice lines

Message displays are being **piggy-backed onto ordinary two-way mobile voice-communications systems** by Sunrise Electro-Service Corp., Farmingdale, N.Y. A small sales and service operation that had been specializing in communications systems, Sunrise has designed both base-station and what it calls Moscan mobile terminals around Burroughs Corp. Self-Scan neon display panels. Messages are transmitted digitally on the system's carrier to activate **32-character panels that can be used for such applications as dispatching taxi fleets, police cars, and messenger services.**

Microcomputers sold to OEMs by Coast firm

Computer Design Corp., maker of programable calculators sold by Monroe and under its own Compucorp name **has begun selling its proprietary microcomputers to OEM customers for use in systems.** The Santa Monica, Calif., company, which has sold about 50,000 calculators containing the sophisticated microcomputer, will sell either a board version or a packaged unit similar to a calculator and including keyboard, magnetic-card unit, and printer. Customers already include a number of scientific and industrial equipment firms.

Computer Design is also introducing peripherals and interfaces for control of instruments by its calculator systems. The firm says **the calculators are considered easier to use than either conventional minicomputers or microcomputer-chip sets**, and are less expensive than minicomputers. The five-chip CPU, which was designed in-house, can interface to 16 I/O devices, directly address up to 16,384 bytes of memory (RAM or ROM), has 250 microinstructions, and provides add time of 160 microseconds.

Cable TV study seen a victim of Watergate

The strong recommendations of President Nixon's Cabinet committee report on cable communications (see p. 50)—despite strong initial support from nearly all affected industries except broadcasters—**lack a powerful advocate within government and are likely to suffer as a result.** That consensus of communications interests in the capital after the report's mid-January release is attributed by a number of industry sources to what one of them called "the overflow of Watergate."

Five of the special seven-man committee members have already left the Nixon Administration, and chairman Clay T. Whitehead is a lame duck, having already expressed a desire to leave soon as director of the Office of Telecommunications Policy. With the departure of former cabinet members Robert Finch, Peter Peterson, Elliot Richardson, George Romney, and Nixon aide Herbert Klein, the only member left is Leonard Garment.

Bowmar to market home-security system for \$399

Bowmar International, a company best known by the public for its line of hand-held calculators, is about to establish another beachhead in the consumer-electronics market **with a \$399 prepackaged home-security system.** Designed to deter burglars, as well as detect fire, the system will operate through a series of so-called digital combination locks, intrusion sensors planted under rugs, and heat detectors placed near ceilings.

A digital keyboard is mounted outside the house near the main entrance. The homecoming resident simply punches in a preselected five-digit combination to disarm the intrusion-detection system before entering the house; a green light on the keyboard lights when this is accomplished. Inside the house, a control panel with a 10-digit keyboard is used with the same combination for the same purpose. The system is powered by standard 110-volt house current and comes with a 12-v standby battery. **One of the additional-cost options offered is an automatic phone dialer to call the police** if a burglar trips the alarm.

Addenda

National Semiconductor appears to have found the American second source needed for its 74C series of C-MOS devices. Harris Semiconductor of Melbourne, Fla., says it will second-source the complete line, and parts are scheduled to begin reaching distributors during the first quarter of the year. Some 23 device types are slated for production during the first six months. **The action will give the National line a boost in its battle with the more widely used RCA 4000 series** RCA has developed a mobile, land-based automated system to check electronics aboard warships. Housed in two vans, Comcerts (for Combat Systems Certification Site) **can be used as much as three nautical miles offshore.**

THE BEST WAY TO SWITCH HIGH POWER LOADS FOR PRECISELY TIMED INTERVALS.

E-LINE ONESHOT POWER PULSERS

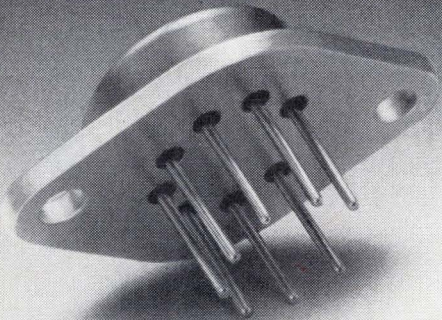

The Unitorde Power Pulser is a hybrid circuit available in two series optimized for switching loads up to 500 watts (60V) for 0.5 to 50ms. Output pulse width tolerance is within 1% of the internally preset time with a temperature coefficient of $-0.04\%/^{\circ}\text{C}$ from 0°C to 125°C . It is a complete, ready-to-use thick film circuit in a compact TO-3 package.

VOLTAGE SWITCH—PIC400

Upon actuation by an input pulse from an IC logic gate, the output of the PIC400 will switch the supply voltage across the load independent of the shape or duration of the input. No external components are necessary. The load may be placed in either the collector or emitter of the darlington output and may be driven from either a positive or negative supply. A wide variety of options are available, including 1800W switching capability (15A, 120V), extended pulse width range (from a fraction of a millisecond to several seconds), and controlled rise and fall rates. The two applications listed below illustrate the versatility of the PIC400.

TYPICAL PIC400 SERIES APPLICATIONS

1. Driving electro-mechanical counter from 24V AC.

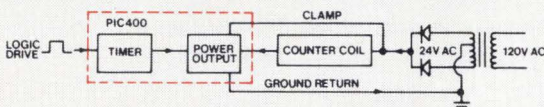

2. Solenoid actuation from negative power supply.

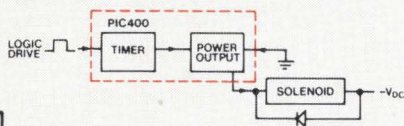

REGULATED CURRENT SWITCH—PIC410

The PIC410 is a more sophisticated version of the PIC400. The output pulse is current regulated to within 1% of an externally preset value by means of a switching regulator in the output circuitry. This insures substantially lower internal power losses and higher efficiency than could be obtained with a series regulator. A rapid turn-off circuit insures the fastest possible current decay upon termination of the output pulse. The range of options available for the PIC410 are the same as for the PIC400. Two typical applications follow.

TYPICAL PIC410 SERIES APPLICATIONS

1. Constant current switching of high speed print-hammer from unregulated supply.

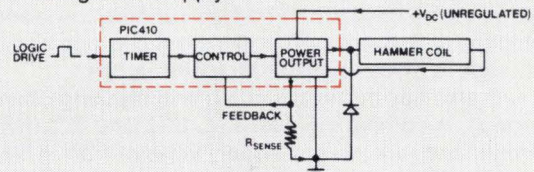

2. Driving high-speed stepper motor (with 5A constant current pulse) from 48V AC.

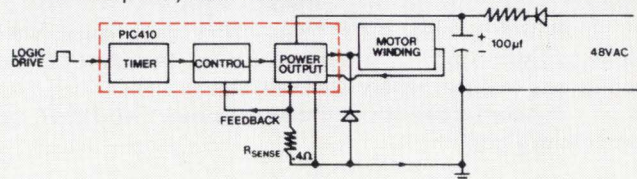

For more specific information call Vinnie Savoie—collect—at (617) 926-0404. Unitorde Corporation, Dept. 25Y
580 Pleasant St., Watertown, Mass. 02172.

See EEM Section 4800 And EBG Semiconductors Section for more complete product listing.



UNITRODE quality takes the worry out of paying less.

Unitorde Sales Representatives: **ALA.**, Huntsville, 20TH CENTURY MARKETING INC. (205) 772-9237; **ARIZ.**, Scottsdale, FRED BOARD, ASSOC. (602) 994-9388; **CAL.**, Burlingame, BROOKS TECHNICAL GROUP (415) 347-5411, Escondido, ANDREW ELECTRONICS SALES (714) 743-3015, Sherman Oaks, UNITRODE CORP. (213) 783-1301; **COL.**, Littleton, SIMPSON ASSOC., INC. (303) 794-8381; **CONN.**, Hamden, COMPAR NEW ENGLAND (203) 288-9276; **FLA.**, Boca Raton, CONLEY & ASSOC. INC. (305) 395-6108, Oviedo, CONLEY & ASSOC. INC. (305) 365-3283, Tampa, CONLEY & ASSOC. INC. (813) 933-3183; **ILL.**, Chicago, CARLSON ELECTRONICS SALES CO. (312) 774-0277; **MD.**, Baltimore, DANIEL & COMPANY (301) 825-3330; **MASS.**, Newton Highlands, COMPAR NEW ENGLAND (617) 969-7140; **MICH.**, Detroit, RATHSBURG ASSOCIATES, INC. (313) 882-1717; **MINN.**, Minneapolis, CHARLES E. BOHLIG CO. (612) 922-7011; **MO.**, St. Louis, CARLSON ELECTRONICS SALES CO. (314) 991-0262; **N.Y.**, Clifton, N.J., COMPAR NEW YORK, INC. (201) 546-3360, Albany, COMPAR ALBANY, INC. (518) 489-7408, Endwell, COMPAR ALBANY, INC. (607) 723-8743, Fairport, COMPAR ALBANY, INC. (716) 271-2230, Liverpool, COMPAR ALBANY, INC. (315) 471-3356; **N.C.**, Burlington, P. J. NAHSER, INC. (919) 226-8053; **OHIO**, Cincinnati, BAEHR, GREENLEAF & ASSOC., INC. (513) 891-3826, Cleveland, BAEHR, GREENLEAF & ASSOC., INC. (216) 221-9030, Columbus, BAEHR, GREENLEAF & ASSOC., INC. (614) 486-4046, Dayton, BAEHR, GREENLEAF & ASSOC., INC. (513) 426-5485; **PENN.**, Willow Grove, DANIEL & COMPANY (215) 674-3850, Pittsburgh, COVERT & NEWMAN CO. (412) 563-0303; **TEX.**, Houston, SEMICONDUCTOR SALES ASSOC. (713) 461-4197, Richardson, SEMICONDUCTOR SALES ASSOC. (214) 231-6181; **UTAH**, Salt Lake City, SIMPSON ASSOC., INC. (801) 521-3622; **WASH.**, Bellevue, N.E.M.C.O. (206) 747-6863; **CANADA**, Downsview, Ontario, KAYTRONICS LTD. (416) 638-5511, Montreal 267, Quebec, KAYTRONICS LTD. (514) 487-3434.

Great American Two-timers

You already know most of the great American two-timers. There was Scarlett and Rhett, Frankie and Johnny, Bob and Carol and Ted and Alice.

And now this country has the Dual 555 Timer, emerging as one of the all-time great two-timers.

Known as the D555, this dual timer has two independent 555 type timers on a single chip. A 14-pin DIP two-timer to save you both board space and money. Instead of using two 555's, you could be using one D555. It costs only \$1.50 for the commercial version, 100-up.

And it two-times your design pleasure, with time delays set by an external R-C network and highly accurate time delays (from microseconds to hours).

Or use it as an oscillator. The free-running frequency and duty cycle of each section are accurately controlled with two external resistors and one capacitor. And the outputs can source or sink 200mA, which is enough to drive relays or indicator lamps.

It also has better matching and tracking characteristics than the old discrete two single-timer approach, is compatible with TTL, DTL and ECL (which is more than anyone can say about Frankie and Johnny), and runs on any supply voltage from 4.5V to 18V.

The D555 is activated by triggering an internal flip-flop with a falling waveform. Once activated, the circuit is immune to additional triggering during the timing cycle. A reset terminal is provided in case the timing cycle must be interrupted.

Which all means that history won't play havoc with your imagination. You can shape the course of time to your liking—in sequential timing, frequency division, pulse shaping, clock pattern generation and hundreds of other timely applications.

To learn more about the world's new Two-Timer, call Teledyne. Or a rep or distributor. History will reward you.



 **TELEDYNE**
SEMICONDUCTOR

1300 Terra Bella Avenue Mountain View, California 94043
(415) 968-9241 TWX: 910-379-6494 Telex: 34-8416

Emitter-follower logic pushes bipolar designs into LSI realm

TRW's new single-chip parallel multiplier contains more than 3,000 bipolar EFL gates

Bipolar LSI, the higher-performing sister technology to MOS, may soon lose its status of stepchild in many semiconductor laboratories. And, although there are other new promising bipolar approaches, such as integrated injection logic, the real Cinderella may be emitter-follower logic (EFL)—a pre-TTL configuration that dates back to the early days of integrated circuits.

An EFL 64-bit parallel correlator for an airborne computer system has been developed at TRW Electronics, Redondo Beach, Calif., and delivered to its systems group. It contains 5,000 devices on a single 220-by-230-mil chip and operates at 20 megahertz.

What's more, the TRW group, using a triple-diffused form of EFL, has just completed a monolithic 16-by-16-bit parallel multiplier—a mammoth 301-by-279-mil superchip containing no fewer than 16,700 bipolar devices, for a gate equivalent of over 3,000. That makes it a candidate for what has become the new logic category: very-large-scale integration, or VLSI.

The multiplier chip is being incorporated into a 16-bit, 6-MHz computer, scheduled for delivery in about six months. The com-

puter, aimed at military and aerospace applications, will use a total of 10 chips, four of which are VLSI. It will have an instruction time of 400 to 800 nanoseconds, making it one of the fastest minis going.

But EFL is not the only bipolar LSI on the move. A 125-gate Schottky TTL accumulator has been available for almost one year [*Electronics*, Aug. 30, 1973, p. 26], and a single-chip Schottky controller with an equivalent-gate complexity of 1,000 is about to emerge. Integrated injection-logic (I^2L) techniques used to make 1,000–3,000-gate circuits are in design in laboratories throughout the world [*Electronics*, Sept. 13, 1973, p. 35] for LSI applications in central processors, instruments, and watches. Even the ancient resistor-transistor-logic technology is being streamlined with modern techniques for LSI duty.

Simple process. TRW is producing the EFL LSI chips only as custom circuits to satisfy its own system re-

quirements, according to Barry Dunbridge, laboratory manager of the Microelectronics Center. However, the logic technique could have great commercial success because it is extremely simple to fabricate. It requires only three diffusions—an n collector, a p^+ base and an n^+ emitter diffusion—and only five photoresist steps. Since mask tolerances and diffusion depths are noncritical, the process's associated yields are high—three good dice out of 19 per wafer.

Dunbridge indicates that several semiconductor manufacturers—Motorola does not deny being one of them—are looking into the possibility of commercially exploiting this triple-diffused EFL process. The EFL process is very old in the history of integrated circuits and, oddly enough, it was abandoned years ago in favor of buried-layer epitaxial construction. One reason was that the desired light collector diffusion was very difficult to control. At that time, low capacitances, which lead to higher speeds, could only be obtained by buried-layer epitaxial techniques. But now, ion implantation can control the collector deposition to 5% variation.

According to Jim Buie, senior scientist at TRW's Microelectronics Center, common collectors play an important role toward simplifying and reducing LSI chip area. Buie, who invented TTL, was instrumental in developing TRW's triple-diffusion EFL process.

Because of the common collectors, the packing den-

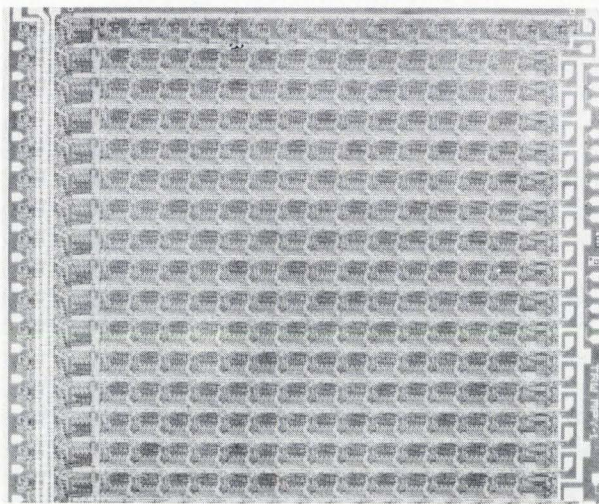

Big chip. Simplified three-diffusion emitter-follower-logic process results in high-yield bipolar logic on 301-by-279-mil chips.

sity of 3D LSI is similar to that obtained with MOS technology, and it has the same manufacturing tolerances. In these circuits, the closest spacing is 3 micrometers—the emitter-to-emitter contact spacing. The smallest metal line is 6 micrometers wide, comparable to standard commercial micro-circuit processing. With these rules, typical layout designs—including busing, pads, and perimeter areas—require only 7–10 mils² per device, or about one-fifth the TTL-device space requirements. A typical master-slave flip-flop, for example, uses 4.6 mils² per device.

According to Dunbridge and Buie, device areas can be still further reduced and performance increased by using an improved process. Cutting dimensions and tolerances in half will increase densities by a factor of four. Then, 300-by-300-mil chips containing bipolar-gate densities of 25,000 per chip—125,000 devices—and capable of operating at speeds in the hundreds of megahertz will be possible. □

Sharp ICs use double diffusion

When the double-diffused MOS process was first announced by a team led by Yasuo Tarui of Japan's Electrotechnical Laboratory, and first produced commercially by Signetics Corp. [*Electronics*, Oct. 13, 1969, p. 207], its greatest promise appeared to be integrated logic and memory circuits capable of high-speed, low-power operation. But only discrete DMOS devices had been built because of the difficulty of separating individual devices in tight LSI geometries [*Electronics*, Nov. 22, 1973, p. 96].

Now, researchers at Sharp Corp.'s Central Research Laboratory have developed two prototype ICs—a shift register and a read-only memory—to check all aspects of integrated DMOS circuits from fabrication difficulties to performance. And the company may soon make the decision to start production of integrated devices using DMOS technology.

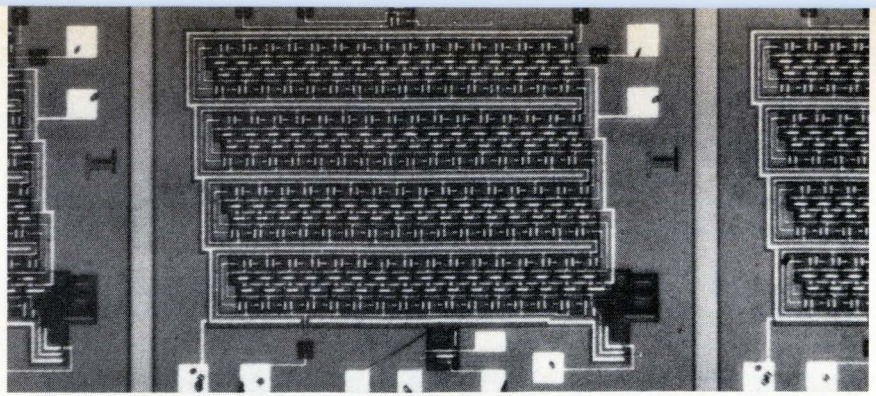

Made in Japan. A 64-bit two-phase dynamic shift register that is made by using the double-diffused MOS process has a chip size of 1.6 by 1.8 millimeters.

The diffusion self-alignment (DSA), as Sharp calls its process, uses the differential diffusion of impurities through a single window in a silicon-dioxide layer on the surface of a semiconductor to define channel length. In these devices, the submicrometer-length channel can be fabricated with the same precision as the width of npn bipolar transistors. This approach gives an n⁺ source and a p⁺ channel having submicrometer length with no need for mask alignment. Good control of channel length is possible because the technique is essentially the same as controlling the base width in bipolar transistors, a well-understood process that is amenable to fine control.

The transistor drain is also an n⁺ diffusion, separated from the p⁺ channel by a p⁻ substrate space-charge region. Control of the impurity level of the p⁺ channel region produces an enhancement-type transistor with low threshold voltage. In addition to high-frequency capability at low operating voltages, the basic structure has a high transconductance that is conducive to a small geometry and thus to increased integration.

The highest circuit speed is obtained by teaming a DSA driver transistor with a depletion-mode conventional MOS load transistor. A single additional n⁺ diffusion region for the drain of the load transistor is sufficient because the drain of the DSA transistor acts as the source of the load transistor. Due to the high resistivity of the substrate, the load transistor is a constant-current device, with its current level set by channel length.

Another virtue of this configuration, with its high substrate-layer resistivity and low diffusion resistivity,

is the capability to fabricate crossunders compatible with the high frequency response of the circuits. The high resistivity of the substrate layer makes for low capacitance, while the low resistivity of the diffusion makes for low series resistance.

One of the circuits is a 64-bit, two-phase dynamic shift register that can drive TTL at clock rates up to at least 50 megahertz. It operates from a single 5-volt power supply and a two-phase clock of similar voltage level, with a power per bit of only 2.2 milliwatts at maximum operating frequency. It can also operate at lower speeds with a power per bit of only 1 W from a single 3-V power supply.

The shift register circuit is conventional with six MOSFET transistors per bit. The driver transistors and the transfer-gate transistors are n-channel diffusion self-aligned types, while the load transistors are conventional n-channel depletion types. Because of the high resistivity of the substrate layer in which the load transistors are fabricated, they operate in a constant-current mode that enhances the high speed of the circuit.

The entire device is fabricated on a chip measuring only 1.6 by 1.8 millimeters. Each bit occupies an area of only 0.016 square millimeter, and thus a 512-bit shift register could be fabricated on a chip measuring 3 mm square. The substrate is p-type and has a resistivity of 100 to 150 ohm-centimeters.

Also built around enhancement-type diffusion self-aligned driver transistors and conventional depletion-type MOS load transistors is a 2,048-bit static ROM, arranged as 256 words of 8 bits each. The memory features fast row and column access times—less than 150 na-

noseconds—with transistor-transistor-gate load. Chip-select is even faster—less than 50 nanoseconds. The circuit achieves this performance operating from a 5-V power supply with a power drain of 60 mW or less. □

Components

Solid-state oscillators sweep X, Ku bands

Solid-state oscillators have been limited to low-power operation, but recent developments may make them formidable competition for backward-wave-oscillator tubes of relatively high powers.

Engineers at Varian Associates Solid State West division in Palo Alto, Calif., report they have boosted continuous-wave power outputs of two classes of tuned Gunn-diode oscillators into the range of backward-wave oscillator tubes. What's more, the diode versions have operated at that power across the two most popular microwave bands—X band (8 to 12.4 gigahertz) with some models and Ku band (12.4 to 18 GHz) with others.

While Varian expects the two classes of oscillators—yttrium-iron-garnet-tuned and varactor-tuned gallium-arsenide Gunn diodes—to displace backward-wave oscillator tubes in new instruments and systems, the two types are not considered competitors with one another. As with earlier designs, the YIG-

tuned oscillators sweep more slowly but more linearly than the varactor-tuned oscillators. It takes a YIG-tuned oscillator milliseconds to sweep across its bandwidth because the sweep rate is slowed by a large tuning coil. Varactor-tuned oscillators sweep in microseconds but are made somewhat nonlinear by the varactor-diode characteristics, explains Jack Talbot, a marketing engineer at Varian.

YIG tuning. Talbot says that full-band YIG-tuned Gunn diodes have generally put out only 10 to 20 milliwatts across X or Ku band, although a few "specials" have reached 25 to 30 mW across the band and get about 100 mW over a 1-GHz range.

The 3-decibel improvement in power over a full band is important, he says, because 50 mW equals the

New chief of the FCC's Common Carrier Bureau backs competition in telecommunications

When Bernard Strassburg retired at year's end as chief of the powerful Common Carrier Bureau at the Federal Communications Commission, the communications industry suspected that the bureau's thrust to encourage competition with AT&T might be blunted. Those suspicions—which grew when Asher Ende resigned as deputy on failing to succeed Strassburg—are being put down by the new chief, Walter R. Hinchman, who has moved over from the commission's Office of Plans and Policy.

Hinchman says that the now independent second phase of the AT&T investigation is "as active as it ever was" under the new but experienced leadership of Peter M. Anderson, a former deputy counsel to the bureau who has long been involved in the AT&T study. Moreover, he adds, Ende will continue to work with the investigation in a consulting capacity to the commission.

As for Ende's successor, who will now be freed from daily involvement in the AT&T case, Hinchman acknowledges that Norman Schwartz, a former bureau counsel, has been widely mentioned in industry as the likely nominee. Yet Hinchman de-

clares he has no favorites among a roster of candidates both inside and outside the commission, adding that he expects to name a successor within a few weeks.

Hinchman's thoughts about competition are not likely to please AT&T executives and may signal a new focus on the telephone monopoly. Basically, Hinchman is more concerned about how AT&T itself competes than initiating new competition for a while.

Views on competition. "We've got the bounds of competition for the time being," Hinchman declares, saying that the commission's decisions on interconnection, specialized common carriers, and long-distance services have set the basic competitive policy. Although not expecting any new areas to be opened for a while, he says the question "we haven't faced up to is how does AT&T compete in the market?"

Under scrutiny will be such issues as fair rates of return, cross-subsidization, and economies of scale, as well as local systems distribution, and terminal and switching equipment. All of this fits into a larger framework; as Hinchman puts it: "What are the terms and conditions

that have to be set up to have competition?"

In that regard, Hinchman doesn't like AT&T's recent counteroffensive to stop or overturn the series of bureau-supported FCC decisions permitting new competition [*Electronics*, Oct. 25, 1973, p. 40]. "I think the response they gave three years ago was more reasonable. They said they wanted to compete and would be formidable competition. I'd like to see them do that now because I think they would be formidable." He also thinks that any move to spin off Western Electric would have to come either from the Justice Department or from a private suit.



output of the small backward-wave oscillator tubes generally used in sweep generators. In systems, the higher power will allow solid-state local oscillators to drive several mixers in multichannel receivers. Multiple channels are used, for example, in phase-locked receivers of electronic-countermeasures systems. Driving mixers with a common local oscillator allows the relative phases of different signals to be measured accurately.

Although detailed specs of the YIG-tuned designs will not be firmed up until some time this month, Talbot says, Varian is already taking orders from several manufacturers. Sample X-band units cost \$1,975, and sample Ku-band units cost \$2,275. The oscillators take up to 1.2 amperes of current at the operating voltage range of 15 to 20 volts.

Talbot credits the rise in power to a number of small improvements in circuit design and to better control of Gunn-diode processing rather than to any breakthrough. These techniques will also be applied soon to higher-frequency oscillators. "We hope to cover the 26-40-GHz range at lower powers."

Varactor route. Varactor-tuned oscillators with power outputs ranging from 10 to 50 mW—several times that of present full-band designs—will be in production in 6 to 9 months, according to James Hice, product manager. Sample quantities of 10-mW designs will be offered soon at about \$3,000 each.

Robert Brown, an engineer working on these designs, says that lab models have reached 10 mW across both X and Ku bands, with experimental designs hitting up to 50 mW in X band and over 30 mW in Ku band. The 10-mW oscillators are also being developed in stripline versions.

Full-band tuning has been achieved at relatively low power levels in the past, according to Hice and Brown, by forward-biasing the varactor through part of the frequency range. Compared with the preferred reverse-biasing technique, forward-biasing causes variations in sweep speeds, stresses the varactor,

and adds to the oscillator's nonlinearities and noise, they say.

The new designs are reverse-biased throughout the band, giving them exceptionally low noise and high sweep speed. "Our fm noise is like that of a good reflex klystron, about 6 dB better than a BWO tube's," Brown reports. And the sweep speed—100 nanoseconds across the band with settling to within 1 MHz of the final frequency within 1 microsecond—is considered just right for frequency-agile radar and for altimeters. Brown expects further work to boost speed.

"How do we do it?" he asks. Again, by a combination of small improvements: a high-Q varactor diode in a low-capacitance package, a linearizing circuit on the varactor-control input, a series rather than parallel tuning circuit, and a better Gunn diode, he answers. □

Packaging

Elastic conductors aid watch packaging

Interconnecting a liquid-crystal display, integrated circuit, quartz crystal, and battery inside a tiny watch case may seem like a tall order for the packaging engineer. But con-

ductive elastomers are easing the problem.

One company specializing in conductive-elastomer connectors is Chomerics Inc., Woburn, Mass., which now supplies connectors to Gruen, Optel, and seven other electronic-watch manufacturers. The connectors are made by molding conductive rubber buttons into a nonconductive plastic retainer. The rubber is made conductive by adding about 20% by volume of metallic fillers.

One of the biggest advantages of elastomers is that the material will not abrade the mating contact, as will metal connectors. This attribute is critical with liquid-crystal displays because their indium-oxide contact surfaces are fragile, being only angstroms thick.

A second advantage is that the connectors are injection-molded, which enables the contacts to be located on tightly spaced centers. These connectors also do away with alignment problems inherent in conventional pin-and-socket arrangements. Elastomers have a higher electrical resistance than do metal contacts, but this characteristic is of little consequence in watch circuits, where electrical currents are so small.

Watches are but one of many po-

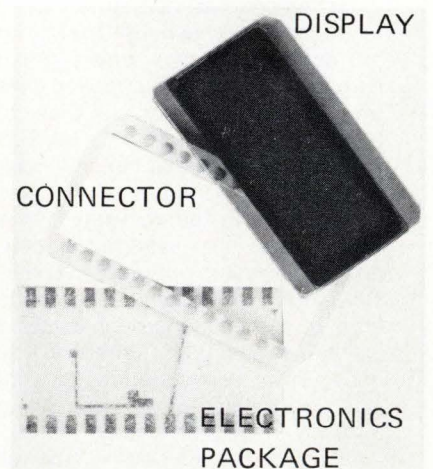
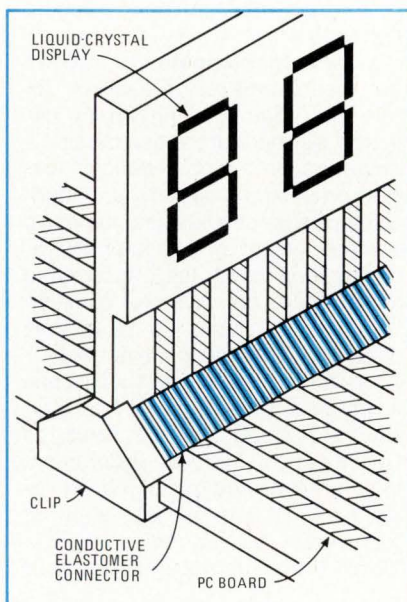

Connect with rubber. Chomerics' conductive elastomer contacts in a plastic retainer connect liquid-crystal display to electronics package (photo). Technical Wire Products' triangular ribbon (drawing) uses alternate conductive and nonconductive layers.

MAKING IT!



The Hybrid Analog TONE GENERATOR

featuring

- tantalum thin film technology
- wide temperature range: -45°C to $+65^{\circ}\text{C}$
- wide voltage range: 4.5V to 35V
- optional polarity guard
- wide range of output levels

Here's where the LC network gets off. The solid state MH8900 is here—the first tone generator of its kind—available now, in quantity. MH8900, the new precise-tone signalling device which goes beyond CCITT standards. Designed for mechanical or electronic switching, the MH8900 gives you rugged, reliable IC and tantalum thin film circuitry in a compact dual-in-line package less than 1.5 inches square. In your telephones. In your datacom applications. In your budget—you know it's right.

MH8900—available now for less than five dollars*, only through Microsystems sales outlets and stocking distributors around the world. Microsystems International Limited, Box 3529 Station C, Ottawa, Canada K1Y 4J1, tel. (613)828-9191.

*1 million quantity, F.O.B. Ottawa, Canada.

 **microsystems
international**
innovation through microcircuitry

tential applications. As Richard Seeger, Chomerics' vice president of engineering, says: "With watch applications bringing conductive elastomers into the marketplace, packaging engineers can learn how workable this material is in other interconnecting jobs."

Triangle. Another firm working with the elastomers is Technical Wire Products Inc., Cranford, N.J., which has devised an unusual connector geometry. It consists of alternate conductive and insulating layers of elastomer rubber and can be used as a connector with contacts spaced as close as 10 mils. The triangular connector can provide an interface for connecting a liquid-crystal display to a printed-circuit board or a thick-film substrate. Small clips can hold the connector in place.

Leonard Buchoff, director of new-product development at the company, points out that most metal systems are impractical at contact spacings below 85 mils. He adds that at about 12 cents a strip, conductive elastomers are far cheaper than gold or tin-alloy contacts.

The elastomer most widely used is a silicone rubber. Its elasticity remains almost constant with age, and it performs well over a wide temperature range. □

Communications

U.S., Japan team to make ground station

Can a small U.S. company find happiness by teaming with a Japanese giant to go after a fat market in satellite ground stations? Maybe so. Digital Communications Corp. (DCC), Rockville, Md.—with total assets of about \$2.5 million—has joined billion-dollar Nippon Electric Corp. Ltd. of Tokyo, to produce a modular earth-terminal design that will use off-the-shelf parts to provide customers with tailor-made gear quickly.

The companies believe that the modular design will put them in a

strong competitive position to tap the growing worldwide earth-station market [*Electronics*, July 19, 1973, p. 69]. DCC estimates that the number of earth stations in the next 10 years will grow to 5,000 to 8,000 units.

One market eyed by the joint venture is Brazil, where an impending domestic satellite system, according to Andrew M. Werth, DCC vice president, would require about 2,500 earth terminals. The market for smaller earth terminals will include burgeoning domestic and regional networks, corporate telecommunications systems, pipeline-support systems, and communications to offshore drilling rigs.

The DCC-NEC terminal, called the Adaptive Satellite Communications Terminal (Ascot), sells for \$100,000 in a typical "bare minimum configuration" for an oil rig, Werth explains. This package includes a 15-foot antenna, up to 300 watts in a power amplifier, an uncooled parametric amplifier, and a "simple up-and-down converter." Says Werth, "We come in, set it up, and point it." Buyers can order options that run the price up to \$400,000. Options can include combinations of voice, digital, and video-transmission packages as well as housing and redundancy equipment.

Modularity, the answer. Since variations in the design of earth stations can be expensive and time-consuming, DCC began talking about a modular design with NEC, and Ascot was born. "During the next 10 years, there will be a continuing demand where customers will suddenly need the kind of hardware NEC makes," Werth says. Such

hardware includes high-power amplifiers, low-noise receivers, microwave up-and-down converters, and antennas. DCC makes the if equipment and NEC makes the rf gear.

Typical specifications for the terminal are: receive-frequency range from 5.925 to 6.425 gigahertz, transmit frequencies, 3.7 to 4.2 GHz.

Antenna diameter varies from 4.5 to 12 meters, power amplifier ranges from 20 to 3,000 watts, baseband equipment is either delta- or pulse-code-modulated for digital and fm for analog, and the frequency-modulation method is two-phase or four-phase shift-key.

Meanwhile, DCC also is doing terminal work for ITT Space Communications and is teamed with Scientific-Atlanta Inc. to build the shipboard terminals, once the Comsat-Navy maritime satellite gets underway to launch a ship-satellite communications market [*Electronics*, Sept. 13, 1973, p. 50]. That project should lead to at least \$300 million worth of terminals over 10 years, Werth says. □

Optics

Waveguide, coupler shrink optics

Thin-film devices for processing light signals promise to do for communications at optical wavelengths what integrated circuitry has done at lower frequencies. Typical of the trend in this new field of integrated optics, in which researchers strive to

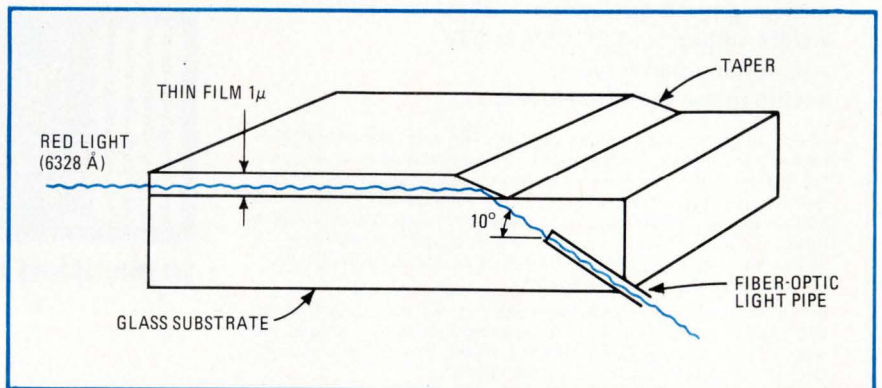

Thin red line. Light couples from thin film and follows tapered edge to substrate to light pipe.

MAKING IT!

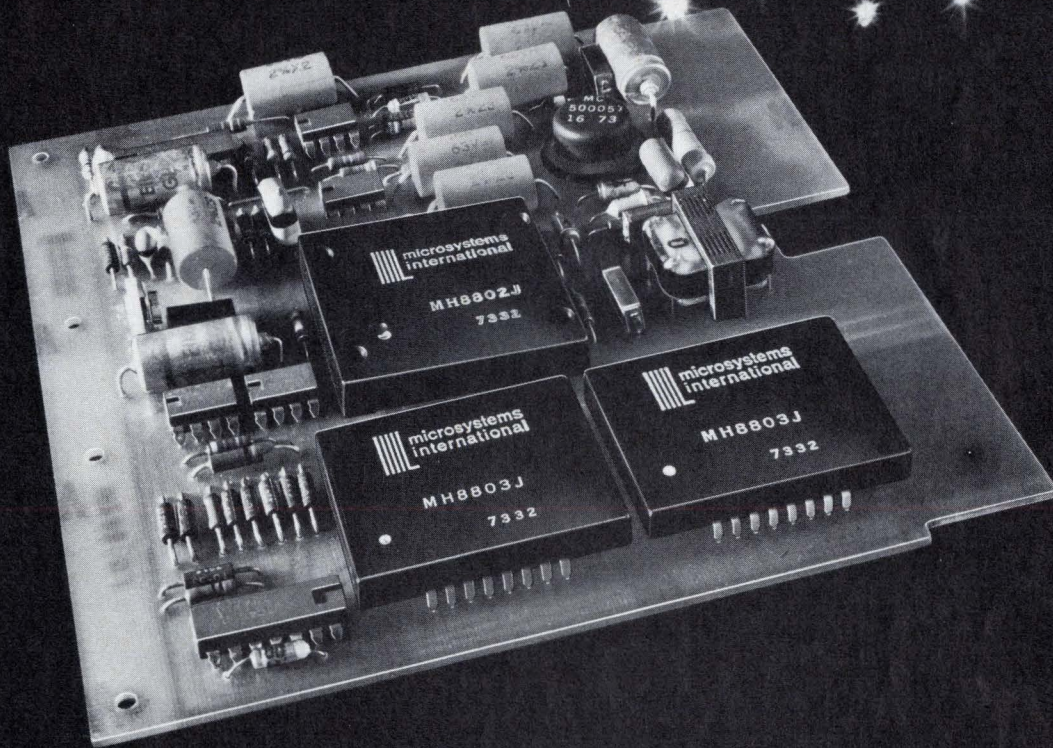

The Solid State TONE RECEIVER

featuring

- tantalum thin film technology
- wide operating ranges: 21V to 35V and 35V to 55V
- two sensitivity ranges: 20mV and 50mV
- rugged, compact 5" x 5" edge connected board

The solid state, precise-tone receiver that makes it in telephone and data terminal applications. Microsystems ME8800 gives you more features for more performance such as thick film and tantalum thin film detectors and filters. Automatic gain control, too. A high Q active filter module provides immunity to false dialing and voice frequencies. The more you look at it, the more you need it. ME8800—available now only through Microsystems sales outlets and stocking distributors around the world. Microsystems International Limited, Box 3529 Station C, Ottawa, Canada K1Y 4J1, tel. (613)828-9191



microsystems
international

innovation through microcircuitry

build miniscule versions of such components as signal sources, detectors, waveguides, and modulators common at microwave frequencies, are two developments at Bell Laboratories, Holmdel, N.J.

One development involves the fabrication of optical waveguide circuits in a polymer film with a loss of only 0.2 decibels per centimeter. The other is a device that couples light from a substrate to a fiber-optic light pipe—the transmission line of an integrated optical system [*Electronics*, May 24, 1973, p. 44].

To form the waveguide, a photochemical reaction is used to implant a dopant in a polymer film, according to physicist W. John Tomlinson of Bell's quantum electronics research group. First, the polymer is deposited on a glass substrate, then a dopant layer is deposited from solution. No vacuum is needed, as opposed to many other thin-film processes, Tomlinson points out.

Upon exposure to ultraviolet light, the dopant undergoes a photochemical reaction that substantially reduces the dopant mobility and volatility, thus implanting, or "photolocking," the dopant in the film. The unreacted dopant molecules are then removed by heating the device in a relatively cool 100°C oven for one hour. This also serves to anneal the film.

After this treatment, the irradiated sections are thicker than the rest of the area and have a refractive index between that of the dopant (1.5 to 1.58) and the unexposed polymer (1.515). Bell researchers expose the polymer, either through a mask or by scribing the film with an argon-laser beam.

The waveguide—about 4 micrometers wide—provides single-mode propagation for red light at 6330 angstroms. The transmission loss is low—less than 1 dB/cm is considered a must—because the process yields a smooth interface between dopant and base, points out another Bell physicist, Heinz P. Weber. Lower losses have been reported in glass materials, but they have been used for wider waveguide structures, he says. For the film, a copolymer of

News briefs

ECM contracts awarded

The Air Force has brightened the new year for Cutler-Hammer's AIL division with a \$31.6 million award to produce the defensive electronic countermeasures gear for the initial B-1 bombers. Teamed with AIL in the B-1 ECM program are Hallicrafters Co., which will supply the jammer, and Sedco Systems Inc. for the antenna portion. The team won the package in competition with Raytheon Co.'s Electromagnetics division.

At the same time, AIL will share in General Dynamics Corp.'s \$2.5 million contract to develop a brassboard ECM system for a competitive flyoff against Grumman Aerospace Corp.'s prototype EF-111A interceptors [*Electronics*, Aug. 30, 1973, p. 42]. Grumman has received a similar contract. The Air Force wants to modify 42 of the F-111s to the electronic-warfare role by retrofitting each with an AN/ALQ-99 tactical jamming system made up of a receiver, computer, and high-power transmitters with directional/steerable antennas.

First U.S. domsat service starts work

RCA began operating the first coast-to-coast domestic satellite communications system this month, beating Western Union, which is scheduled to put its system into orbit this spring. But, whereas Western Union will use its own Hughes satellites, RCA has for the time being put transponders on board Canada's Anik-2 satellite, also built by Hughes, to interconnect terminal in New York, San Francisco, and Juneau, Alaska. In 1976, however, RCA will launch three company-built, 24-channel satellites to operate with a full network of earth stations.

Fairchild discontinues SX-70 modules

After completing delivery commitments through the first quarter of 1974, Fairchild Camera & Instrument Corp. will discontinue supplying two of the three control modules for the Polaroid Corp. SX-70 camera. Fairchild has attributed the decision to a failure to reach an agreement on price and volume terms in a renewal of Fairchild's contract. Polaroid selected Texas Instruments to supply two of three modules Fairchild had been delivering.

Methode moves to additive technique

Methode Electronics Inc., Chicago, under a licensing agreement from the Photocircuits division of Kollmorgen, Glen Cove, N.Y., has begun volume production of printed-circuit boards using the additive process, whereby copper is placed selectively on the pc board. Methode's facility can now deliver one million square feet of the boards per year.

NCR uses optical scanning with new computer

An accounting computer using an optical-scanning program has been introduced by National Cash Register Co. Called the model 299, the computer has a scanner that detects the presence or absence of reflected light from pencil or pen marks on a special program-assembly card, enters the information on a microprogrammed MOS ROM, and executes operations according to the programed instruction. Price of a basic unit is \$7,250.

DOT plans to automate freight cars

About \$35 million has been ticketed by the Department of Transportation for a new computerized accounting system to keep tabs on the nation's freight-car fleet. The allocation is part of a proposed \$2 billion rail-aid program unveiled this month, and should speed the award of a \$2.5 million computer contract that is under way at the Association of American Railroads.

IBM pioneer retires

Thomas J. Watson Jr., son of IBM's founder, and himself a pioneer in computer technology, retires this month at IBM's mandatory retirement age of 60.

MAKING IT!

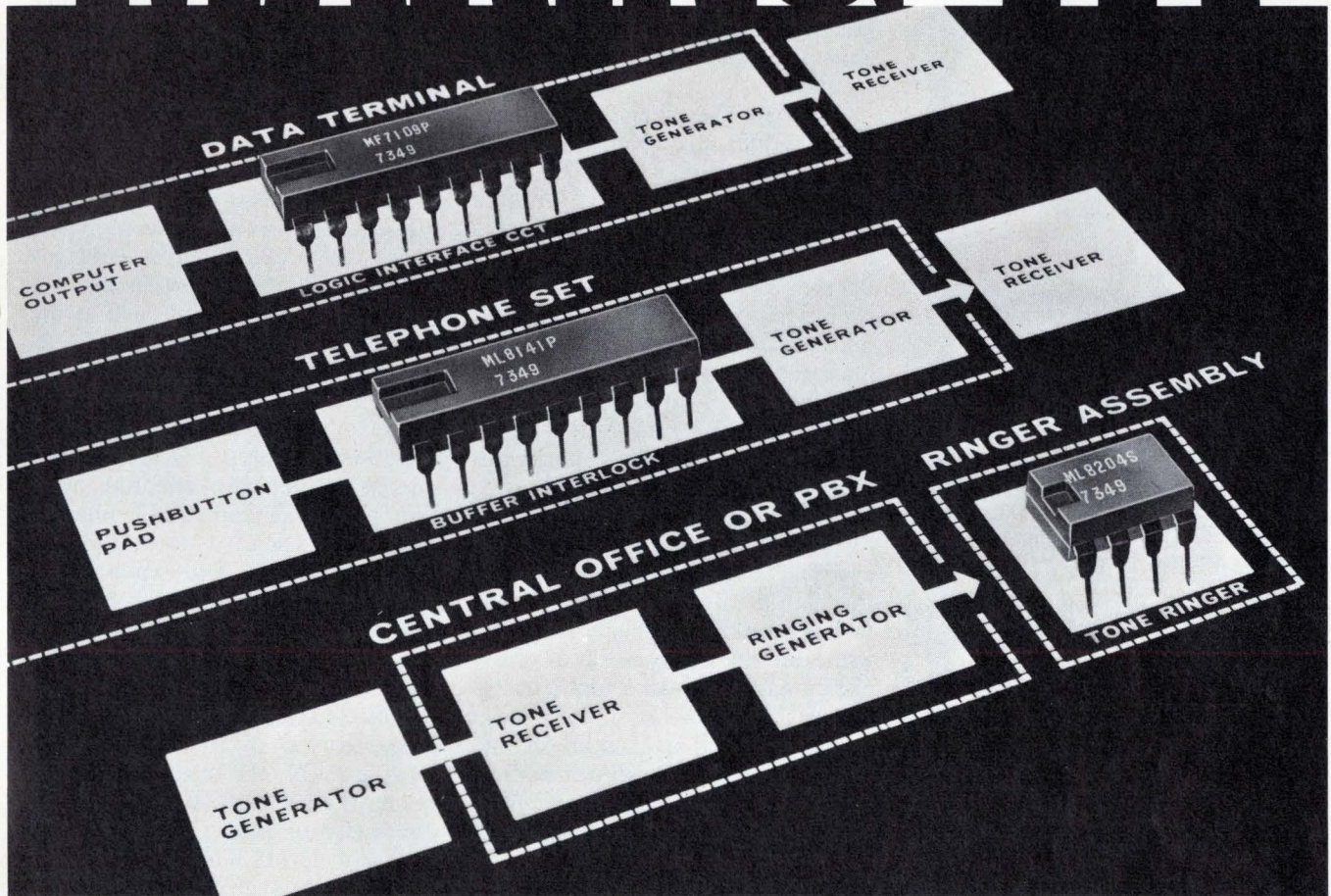

The Total Tone Signalling System

Microsystems gets it together with its interfacing I.C.'s

● LOGIC INTERFACE CIRCUIT

MF7109 electronically converts your computer's 4 bit binary code to key the MH8900 tone generator for fully automatic data transmission or automatic dialing.

● BUFFER INTERLOCK

ML8141/8142 enables simple, foolproof mechanical switching of the tone generator. It locks out errors caused by pushing two buttons simultaneously. It also acts as a low impedance buffer to provide better RF immunity.

● TONE RINGER

ML8204 the audio oscillator that replaces the standard telephone bell with a prestigious pleasant sounding warbling tone.

They're all available now, only through Microsystems sales outlets and stocking distributors around the world. Microsystems International Limited, Box 3529 Station C, Ottawa, Canada K1Y 4J1, tel. (613)828-9191.

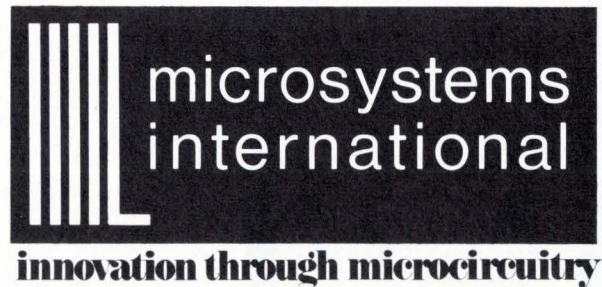

triacs

T066



These economical, highly reliable triacs are the result of Hutson's advanced thyristor technology which includes patented construction of void-free glass-passivation chips. This series features:

($I_{T(RMS)}$) to 15 Amps
(V_{DROM}) to 600 Volts

In addition to these TO66 packaged triacs, Hutson's complete line of triacs and scr's are available in all popular packages in current ratings to 60 Amps and voltage (V_{DROM}) ratings to 600V.

Call or write for complete information.



HUTSON INDUSTRIES

BOX 34235 • 2019 W. VALLEY VIEW,
DALLAS, TEX. 75234 (214) 241-3511
TWX 910-860-5537

Distributed by:

In U.S.A.: BODELLE CO., INC.,
Chicago, Ill. 312/468-1016;
THOR ELECTRONICS, Elizabeth,
N.J. 201/354-2430.

In Canada: SEMAD ELEC-
TRONICS, Downsview, Ont.
416/635-9880.

Hutson Industries International
TAYEB BERNOUS Vice-President
30 Rue Pierre Semard, Yerres,
91 France • Tel: Paris 925-8258
TELEX 21-311

In Europe:
Belgium: C.N. ROOD S.A., Brus-
sels 02-352135. Denmark: E.V.
Johanssen A/S, Copenhagen
(01)* 295622. Norway: INTELCO,
Oslo, 47 2 207451. Spain: BEL-
PORT, Madrid 234.62.62. Swe-
den: ELEKTROFLEX, Sundyberg
08-28-9290. Switzerland: D.
LEITGEB, Dubendorf 051 85
9666. UK: CLAUDE LYONS,
LTD., Hoddeston, Hertfordshire
(09924) 67161.

Electronics review

methyl-methacrylate and glycidyl-methacrylate is used; the dopant is an ethyl acrylate—two materials related to Plexiglass. In addition, two thin-film waveguides have been placed close enough together to obtain a directional coupler effect as light is coupled from one guide to the next.

Tapered. The other Bell development tackles the problem of coupling light out of a thin-film material. If the edge of a thin-film material is carefully tapered, says P. K. Tien, head of Bell's Electronic Physics Research department, light projected at the taper through the film will not pass into the surrounding air. Instead, it propagates along the tapered edge and down into the substrate. Making use of this observation, Tien deposited an organic film of vinyl trimethylsilane on a substrate with a tapered edge, then he tunneled into the substrate and placed an optical fiber there in the path of the light. Light loss due to the coupling was 3 dB. But Tien, who describes the work as "very preliminary" hopes to improve this figure.

Tien, as well as Tomlinson and Weber and their co-workers at Bell, Edwin A. Chandross and Coralie A. Pryde, are describing their research this week at a conference on integrated optics in New Orleans. □

Commercial electronics

Scientists have a choice of calculators

Of all the hand-held scientific calculators introduced at the Winter Consumer Electronics Show in Chicago, the talk centered around one that wasn't there. Texas Instruments waited until its booth was packed back into the shipping cartons, and then pulled out its new SR-50.

TI had good reason not to unveil the unit to the show's buyers. Taking leaf from the book that Hewlett-Packard wrote, TI will sell it by direct mail only. Functionally, the SR-50 fits between the HP-35 and 45.

But its price—\$169.95—undercuts most of the units at the show.

Most of the scientific calculators introduced used variations on the Rockwell Microelectronics division's single calculator chip. These units' functions include algebraic entry, four-function plus trig and inverse trig, natural and common logs, powers and square roots, pi, reciprocal memory, and the ability to work in either degrees or radians.

But the two-chip TI machine features hyperbolics and inverse hyperbolics, factorials, squares, and n^{th} roots. An internal processing sequence allows problems such as the sum of products to be entered left-to-right, the equivalent of an additional memory.

Except for the H-P machines, the SR-50 is the only full scientific unit on the market with scientific notation. The calculator's 13 internal digits are rounded to a 10-digit mantissa and two-digit exponent.

TI used ion-implantation on both MOS chips to achieve a total chip power dissipation of about 125 milliwatts for longer battery life. The 233-by-240-mil arithmetic chip is equivalent to over 12,000 transistors—probably the most complex on the market. The second chip is a sequentially-accessed, virtual-ground ROM with 13,312 bits of storage.

The least expensive scientific calculator shown also uses scientific notation. The tiny 12-function Sinclair Scientific, with 5-digit mantissa and 2-digit exponent at \$119.95, is based on a single chip developed at Sinclair's laboratories in St. Ives, Great Britain, and reportedly manufactured by TI (see p. 53). The size, 4.3 by 1.9 by 0.7 inches, was maintained using dual-function keys. Powers and roots must be computed using log and antilog keys.

Other entries, all using the Rockwell chip, are eight-digit units without scientific notation. They include the Bowmar MX 100 at \$179.95, JCE Inc.'s 80 at \$179.95, JCE 90 at \$159.95, Keystone-Omega 4030 at \$194.95, Lloyd's Accumatic 999 at \$199.95, Rapidman 825 at \$179.95, Unicom 202SR at \$195.00, and Unitrex 80SR at \$199.95. Except for the Keystone machine, all use dual-

MAKING IT!

NORTH AMERICA

direct sales offices

CANADA

ONTARIO	
Ottawa Microsystems International Limited	(613) 828-9191
Toronto Microsystems International Limited	(416) 279-1358
QUEBEC, Montreal	
Microsystems International Limited	(514) 931-7055

UNITED STATES OF AMERICA

CALIFORNIA	
Palo Alto Microsystems International Inc.	(415) 493-0848
Santa Ana Microsystems International Inc.	(714) 979-6522
ILLINOIS, Schaumburg	
Microsystems International Inc.	(312) 894-7660
MASSACHUSETTS, Waltham	
Microsystems International Inc.	(617) 890-2255
MINNESOTA, New Hope	
Microsystems International Inc.	(612) 546-9336
NEW JERSEY, Morris Plains	
Microsystems International Inc.	(201) 639-8050
PENNSYLVANIA, Huntingdon Valley	
Microsystems International Inc.	(215) W17-5641/2

sales representatives

CANADA

BRITISH COLUMBIA, Vancouver	
R.A.E. Industrial Electronics Limited	(604) 687-2621

UNITED STATES OF AMERICA

ALABAMA, Huntsville	
20th Century Marketing Inc.	(205) 772-9237
ARIZONA, Scottsdale Barnhill Five Inc.	(602) 947-7841
CALIFORNIA	
Los Altos W. W. Posey Co.	(415) 948-7771
San Diego Transdynamics Inc.	(714) 298-8215
Santa Ana Rical Associates	(714) 557-6543
COLORADO, Denver Barnhill Five Inc.	(303) 934-5505
FLORIDA	
Fl. Lauderdale G. F. Bohman Assoc. Inc.	(305) 564-3081
Oriando G. F. Bohman Assoc. Inc.	(305) 855-0274
ILLINOIS, Chicago L-Tec Inc.	(312) 286-1500
INDIANA, Gassner & Clark Company	(312) 764-6121
MARYLAND, Towson L.H. Kolman Co.	(301) 752-8756
MASSACHUSETTS, Waltham Rantek Inc.	(617) 890-5110
MICHIGAN Tom Mulligan & Associates	(616) 457-2242
MISSOURI	
Hazelwood Technical Representatives Inc.	(314) 524-6900
Peculiar Technical Representatives Inc.	(816) 331-7744
NEW JERSEY, Cherry Hill	
A. B. C. Electronic Sales	(609) 779-9282
NEW MEXICO, Albuquerque Barnhill Five Inc.	(505) 299-7658
NEW YORK	
Cicero Advanced Components Inc.	(315) 699-2651
Tarrytown A. B. C. Electronic Sales	(914) 631-2650
Williston Park A. B. C. Electronic Sales	(516) 747-6610
OHIO, Cincinnati Ron Makin & Associates	(513) 232-5588
OREGON, Beaverton Arneson Associates Inc.	(503) 643-5754
PENNSYLVANIA, Huntingdon Valley	
A. B. C. Electronic Sales	(215) 947-5641
TEXAS, Richardson Campion Sales	(214) 238-5145
UTAH, Salt Lake City Barnhill Five Inc.	(801) 487-1327
VIRGINIA, Alexandria L. H. Kolman Co.	(703) 768-1660
WASHINGTON, Seattle	
Arneson Associates Inc.	(206) 762-7664

stocking distributors

CANADA

BRITISH COLUMBIA, Vancouver	
R.A.E. Industrial Electronics Limited	(604) 687-2621
ONTARIO, Malton	
Semiconductor Specialists	
(Canada) Limited	(416) 678-1444

QUEBEC, Montreal	
Future Electronics Corporation	(514) 735-5775
UNITED STATES OF AMERICA	
ARIZONA, Scottsdale Barnhill Five Inc.	(602) 947-7841
CALIFORNIA	
Carson Hi-Roll Distributor Sales	(213) 537-6500
Menlo Park Bell Industries	(415) 323-9431
Riverside Electronic Supply	(714) 683-5591
San Carlos Sterling Electronics Inc.	(415) 592-2353
San Diego Sterling Electronics Inc.	(714) 565-2441
Sun Valley Sterling Electronics Inc.	(213) 767-5030
COLORADO, Denver Barnhill Five Inc.	(303) 934-5505
FLORIDA, Clearwater	
Southeast Electronics Inc.	(813) 443-4514
ILLINOIS	
Eik Grove Village Diplomat/St. Louis Inc.	(312) 595-1000
Elmhurst Semiconductor Specialists Inc.	(312) 279-1000
Skokie Bell Industries	(312) 965-7500
INDIANA, Indianapolis	
Semiconductor Specialists Inc.	(317) 243-8271
MARYLAND	
Baltimore Arrow Electronics Inc.	(301) 247-5200
Rockville Pioneer Washington Electronics Inc.	(301) 424-3300
MASSACHUSETTS	
Boston De Mambro Electronics	(617) 787-1200
Cambridge Wilshire Electronics	(617) 491-3300
Dedham Gerber Electronics	(617) 329-2400
Waterloo Sterling Electronics Inc.	(617) 926-9720
MICHIGAN, Detroit	
Semiconductor Specialists Inc.	(313) 255-0300
MINNESOTA, Minneapolis	
Semiconductor Specialists Inc.	(612) 854-8841
MISSOURI	
Kansas City Semiconductor Specialists Inc.	(816) 452-3900
St. Louis Diplomat/St. Louis Inc.	(314) 645-8550
St. Louis Semiconductor Specialists Inc.	(314) 428-6100
NEW JERSEY, Cinnaminson	
Wilshire Electronics	(215) 627-1920
Haddonfield Mid-Atlantic Electronics	(609) 428-8288
Kenilworth Newark Electronics Corp.	(201) 272-8410
Saddlebrook Arrow Electronics Inc.	(201) 797-5800
NEW MEXICO, Albuquerque Barnhill Five Inc.	(505) 299-7658
NEW YORK	
Farmingdale, Long Island	
Arrow Electronics Inc.	(516) 694-6800
Freeport, Long Island Milgray Electronics Inc.	(516) 546-6000
Johnson City Wilshire Electronics	(607) 797-1236
Plainview, Long Island	
Newark Electronics Corp.	(516) 822-5000
Rochester Simcona Electronics Inc.	(716) 328-3230
OHIO, Dayton Semiconductor Specialists Inc.	(513) 278-9455
TEXAS	
Dallas Semiconductor Specialties Inc.	(214) 358-5211
Dallas Sterling Electronics Inc.	(214) 357-9131
Houston Sterling Electronics Inc.	(713) 623-6600
WASHINGTON, Seattle	
Sterling Electronics Inc.	(206) 762-9102
WISCONSIN, Wauwatosa	
Semiconductor Specialists Inc.	(414) 257-1330
EUROPE	
direct sales offices	
WEST GERMANY	
STUTTGART Microsystems International GmbH	(0711) 65 31 16/26
UNITED KINGDOM	
LONDON Microsystems International Limited	(01) 402-5521
stocking distributors	
DENMARK	
Copenhagen Erik Westerberg A/S	91 90 00

FINLAND	
Ahertajantie Finn Metric Oy	460 844
FRANCE	
Boulonge Billancourt	
International Semiconductor Corporation	(8) 604 52 75
GERMANY	
Berlin Jastron	030/3121203
Hellbronn Auriema Distribution GmbH	96/52054
Karlruhe ISA Elektronik	0721/43975
Lehrte/Han. Altron	05132/2629
Munchen Radio & Radat	089/146081-85
Tier Gustav Pese	0651/73270
ITALY	
Milano Silverstar Ltd.	(02) 4996
NORWAY	
Kjellergt Kjell Bakke & Co.	271 1872
SWEDEN	
Alvjo-Langsvogden Stahberg & Nilsson A.B.	08- 47 29.80
SWITZERLAND	
Wettingen Elbatex AG	56/622553
UNITED KINGDOM	
BIRMINGHAM Hawnt Electronics Ltd.	021 359 4301
CHESHIRE, Altrincham	
Woolley Components Ltd.	061 928 2289
ESSEX, Harlow Diatronic Limited	027 96 32947
HANTS, Portsmouth Phoenix Electronics Ltd.	07 018 73441
SURREY, Egham	
Athena Semiconductors Marketing Ltd.	389-6161
SUSSEX, East Grinstead Barlec.	0342 24383
SCOTLAND, Glasgow Spenco Electronics	035 52 36311
JAPAN	
stocking distributor	
JAPAN, Tokyo Mitsui & Co. Ltd.	505-1111



Ready when you are.
Everywhere!

- MH8900 series Tone Generators
- ME8800 series Tone Receivers
- MF7109 Logic Interface Circuit
- ML8141/8142 Buffer Interlock
- ML8204 Tone Ringer

Specifying is one thing. Getting is often another. Nothing is more frustrating than waiting. But you don't need to wait for Microsystems line of tone signalling products because they're available now only at Microsystems sales outlets and distributors worldwide. Microsystems modern 340,000 sq. ft., 1500 man R & D and production complex takes care of it. But don't take our word for it. Ask the telecom/datacom people who are already using over 100,000 of them . . . and then decide. Microsystems International Limited, Box 3529 Station C, Ottawa, Canada K1Y 4J1, tel. (613)828-9191.

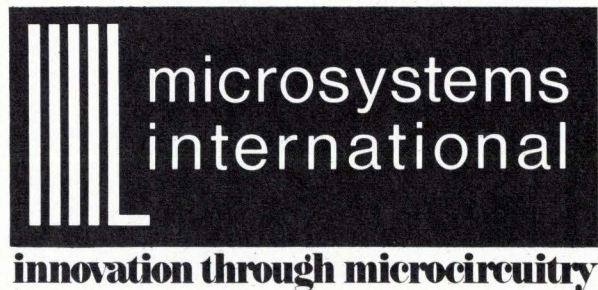

microsystems
international

innovation through microcircuitry

Finally!
A filter so precise,
filter characteristics
for every setting
are printed
on top.

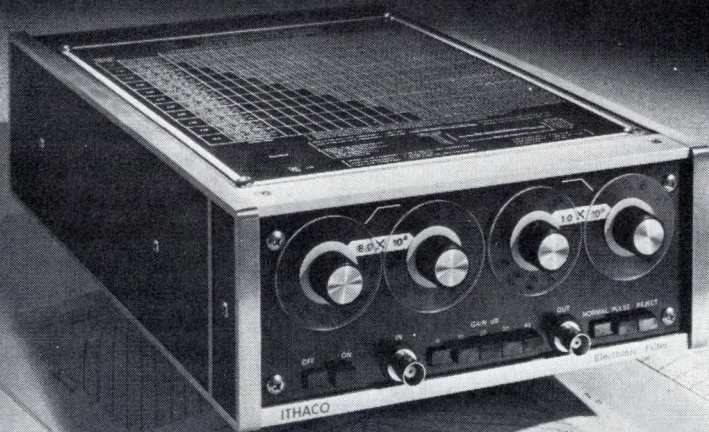

We've built a variable electronic filter that's so precise, it has enabled us to print the cutoff frequencies, center frequency, bandwidth, noise bandwidth and filter gain, for every setting, *on top of the instrument*. Besides being the easiest-to-use filters on the market, our 4200 series filters are twice as accurate, have less than half the self-noise, and provide 10 dB greater outband rejection than any other filters. Frequency coverage is .01 Hz to 1 MHz. Built-in selectable post-filter gain and remote preamplifiers are optional. A Butterworth response is used in the NORMAL mode and a Bessel response in the PULSE mode (transient response is superior to conventional "RC" or "Low Q" modes of other filters).

The price? \$695.

For complete specifications and your free copies of our variable electronic filter application notes, write to: Ithaco, Inc., Box 818-7R, Ithaca, New York 14850. For immediate response, call Don Chandler at 607-272-7640 or TWX 510-255-9307.

ITHACO

Electronics review

function keys, and all are standard pocket-calculator size except the Sinclair and the JCE 90. □

Auto electronics

Computerized tester speeds car repairs

The first checkout system from an American company to pinpoint automatically trouble spots in automotive vehicles was introduced last week by Hamilton Standard, a division of United Aircraft Corp., Windsor Locks, Conn.

"It takes the guesswork out of making car repairs," says Hamilton Standard president Richard F. Gamble. In the system, called Autosense, sensors measure such things as ignition performance and exhaust emissions under control of a central digital computer. The computer compares the conditions against performance specifications stored in its memory, producing a printout that lists what conditions failed the tests and what repairs, adjustments, or other actions should be taken.

Autosense is actually the second such system to be introduced. The first was developed some three years ago by West Germany's Volkswagenwerke AG, which worked with Siemens AG, Munich.

The Hamilton Standard system can be used to tune up cars and trucks to keep them at their fuel-conserving peak efficiency and for testing and repairing emission controls. The performance specifications for more than 2,000 models can be kept in the memory. A complete car can be plugged into the system and checked in about 10 minutes.

Some 50 Autosense systems, priced at \$6,985 each, have been completed in pilot production. Sun Oil Co. and GMC Truck and Coach division of General Motors Corp. have bought the equipment, says Gamble. Ford Motor Co. has also helped in developing the system and field-tested it in the San Diego area last year. □

The AD528.

Where high accuracy joins high speed in a FET op amp.

It's all here in the AD528. First take the speed: a slew rate of $70\text{V}/\mu\text{sec}$ and a bandwidth of 10MHz – with no external compensation – that gives you a clean response, minimal ringing and no oscillation. Even with a 300pF load.

Then combine it with an input bias current of 10pA , an offset voltage of 1mV , a V_{os} drift of $15\mu\text{V}/^\circ\text{C}$ and a peak to peak noise of less than $5\mu\text{V}$.

Put them all together and you've got a FET op amp that's perfect for high speed integration, sample and hold, and current to voltage conversion for D to A applications.

And you can't beat that for only \$12 in hundreds for the AD528J.

The AD528 is the FET input version of our 60° phase margin bipolar AD518. That one has the bandwidth and the speed but a little less accuracy. And a little lower cost. The AD518K. \$4.95 in hundreds.

The AD528 and the AD518. Just two more ways to keep you – and us – a step ahead of everyone else. From the high performance linear IC people at Analog Devices Semiconductor, Norwood, Massachusetts 02062. (617) 329-4700.

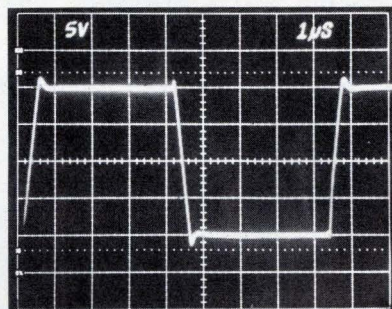

Transient response for the AD528

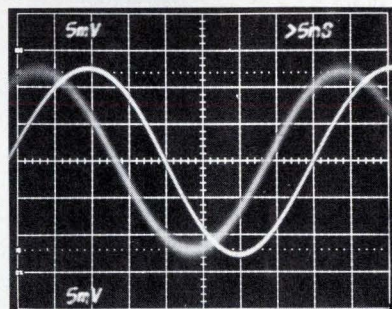

Phase margin for the AD528

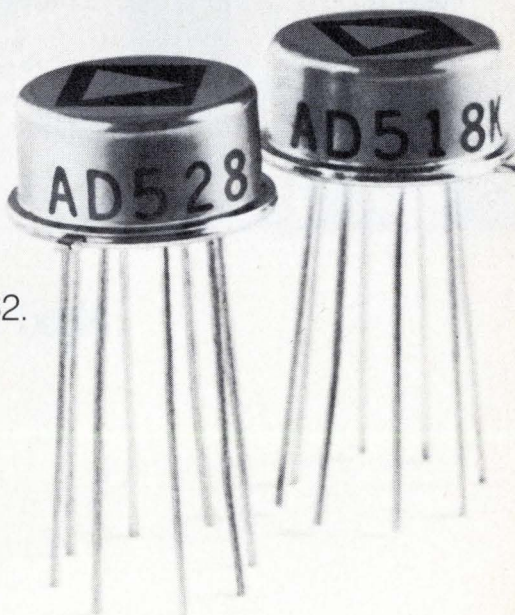



Next time you're in town



drop by the plant.

That gives you a lot of towns to choose from. TRW Electronic Components has 30 plants in 28 towns in four countries. As of today.

Tomorrow? Well, let's just say that 30 plants are none too many. We make well over 300 distinctly different kinds of components. For the major OEMs in all major industries that use electronics. And the demand keeps growing.

What's more, as one of the few companies mak-

ing both high-technology and high-volume components, we are often called on to apply our know-how in one area to the other. That sometimes means building still another plant.

In any case, we keep having to make ourselves at home—in new home towns.

So please don't write in those four blank squares, above. We may be needing them pretty soon. Because we are TRW.

TRW ELECTRONIC COMPONENTS

10880 Wilshire Blvd., Los Angeles, CA 90024

Connectors • Resistors • Semiconductors • Capacitors • Motors • Functions and Assemblies • PC Boards • Potentiometers • Transformers • Coils and Inductors • Wire and Cable

CHALLENGE:

Solve your tropo problems without filling in this coupon.

My tropo problem is:

- EXCESSIVE DOWN TIME—a. equipment fails frequently; b. failures are difficult to identify.
- HIGH MAINTENANCE COSTS—a. hard-to-find highly skilled technicians are needed to keep system operational.
- UNRELIABLE COMMUNICATIONS—a. poor combining b. signal fades; c. equipment needs constant peaking.
- RESTRICTED SIGNAL HANDLING CAPABILITY—a. system won't handle digital data; b. not enough channels to handle the traffic.
- OTHER _____

Send me information on how your modular, solid-state radios can get rid of my problem.

Name _____ Title _____

Firm _____

Address _____ City, State, Country _____

Mail to: Motorola Government Electronics Division, Communications Operations, 8201 E. McDowell Rd., Scottsdale, AZ 85257, USA. For even faster relief, call (602) 949-2811 or call one of our international offices listed under Motorola Military and Aerospace Electronics in Canada, England, France, Germany, Holland or Italy.

ED-1

It's a rigged challenge because Motorola has the newest, solid-state radio using predetection combining for troposcatter communications systems that is designed specifically for this application and is now in production. For example, if down time is the problem that particularly concerns you, remember:

He who lives by the band-aid shall die by the band-aid.

It's possible to live with constant re-adjustment, re-building and repair out in the boondocks. If you can convince highly trained personnel to move to the middle of nowhere and spend all their time tinkering equipment back to life.

Unfortunately, anyone smart enough to do the job is also smart enough not to want to do the

job. Let's face it, would you want to spend your life replacing tired vacuum tubes?

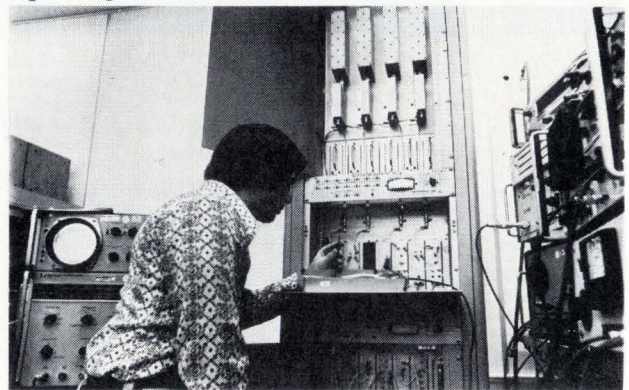

What's the MTTR? One of our engineers claims: "Even a clumsy guy off the street could make a worst-case module replacement in 5 or 6 minutes."

Here we are now that you need us.

Motorola's new L, S, and C-band equipment solves the problems that cause manpower problems. Mean Time Between Failure is calculated at over 4,000 hours. And even if something goes wrong with key elements, nothing goes wrong. Redundant equipment automatically switches over to avoid service interruption. A visual alarm blinks, an audio alarm sounds, built-in test equipment with automatic fault isolation tells which module should be jerked out and replaced with a spare...in seconds. And these common sense maintenance procedures can easily be learned by almost anyone.

Reliability plus new heights of performance.

A new concept in predetection combining became a practical, problem-free reality when integrated circuit technology was pushed to new limits. At Motorola we developed this new signal processing technique that delivered a 10-to-1 improvement in bit error rate over existing troposcatter equipment in a test by the Rome Air Development Center in Rome, New York.

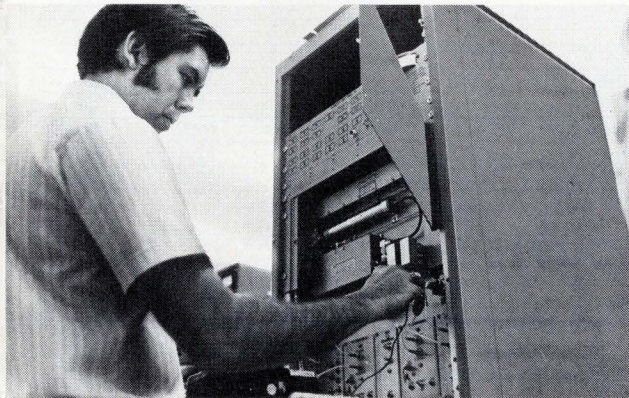

All solid state circuitry and JAN spec components virtually eliminate major maintenance problems...and modular design has made routine maintenance a breeze.

Motorola tropo radios will give your system the flexibility to handle digital data in addition to the usual analog FDM modes. Plus lower maintenance costs, and a noise/power ratio (NPR) of 55 dB for 252-channel operation.

It isn't a paperwork dream.

Bell Canada is now installing Motorola MTR-1000 production units to modernize stations to carry high quality public communications across Labrador from Newfoundland to Quebec.

Bell's decision to modernize with Motorola tropo radios was based upon substantial savings in maintenance, increase in channel capacity and

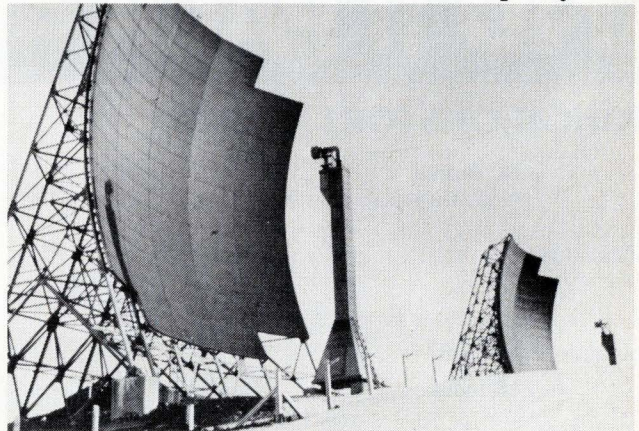

Out in the wilderness human engineering, conservative design and ultra reliability become critical. Bell Canada knows. They chose Motorola's MTR-1000 radios.

improved circuit performance over their old equipment. Tests have shown a 10-to-1 improvement in bit error rate can be realized by using fully redundant predetection combining with the following features:

- Quadruple diversity receiver capability
- Dual exciter with automatic switchover
- Modular design
- Unique fault isolation techniques
- Latest circuitry advances
- 70 MHz IF exciter and receiver interface

But that's only part of the story. Fill in the coupon, and we will send you the facts how the solid state tropo radios can reduce costly maintenance problems, provide improved reliability, and substantially boost performance.

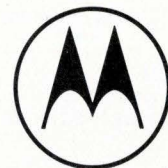

MOTOROLA

... new thinking in electronics

Do you face
a make or buy
decision on
power supplies?

BUY LAMBDA'S NEW 65 AMPERES. LX SERIES NOW AND 11 PACKAGE SIZES.

SPECIFICATIONS FOR LX SERIES

DC Output

Regulated Voltage

regulation, line 0.1%
regulation load 0.1%
ripple and noise 1.5 mV RMS, 5 mV pk-pk with
either positive or negative terminal grounded
temperature coefficient 0.03%/°C

AC input

line 105-132 VAC; 47-440 Hz. For
187-242 VAC, see A.C. input
options. For operation of LXS-E,
LXS-EE, LXS-7, and LXS-8 units
at 50 Hz or at 400 Hz, consult
factory. Ratings apply to 57-63
Hz. For all other models delete
40°C rating for 50 Hz operation.

Ambient operating temperature range

continuous duty from 0° to +71°C with corresponding load
current ratings for all models of operation.

Storage temperature range

-55°C to +85°C

Overload protection

Thermal

thermostat, automatic reset when over-temp. condition is
removed. (Not applicable to LXD-3); circuit breaker must be reset
on LX-7 and LX-8 models.

Electrical

external overload protection, automatic electronic current limit-
ing circuit limits the output current to the preset value,
thereby providing protection for load as well as power supply.

Overshoot

no overshoot on turn-on, turn-off or power failure.

Input and output connections

through terminal block on chassis; output terminals on LX-7,
LX-8 models are two heavy duty studs.

Power hybrid voltage regulator or integrated circuit regulation

some models have Power Hybrid Voltage Regulator providing
complete regulation system while others have an integrated
circuit providing regulation system except for input and output
capacitors, rectifiers and series regulation transistors.

Controls

DC Output Control

simple screwdriver voltage adjustment over entire voltage
range.

Remote sensing

provision is made for remote sensing to eliminate effect of
power output lead resistance on DC regulation.

Transformer

MIL-T-27C, Grade 6

Tracking accuracy (dual models)

2% absolute voltage difference; 0.2% change for all conditions
of line, load and temperature.

5 VOLTS ±5% SINGLE OUTPUT

MODEL	MAX. AMPS AT AMBIENT OF:				PRICE
	40°C	50°C	60°C	71°C	
LXS-A-5-OV*	4.0	3.4	2.7	2.0	\$ 85.
LXS-B-5-OV*	5.8	5.0	4.0	3.0	125.
LXS-4-5-OV*	7.4	6.5	5.4	3.9	135.
LXS-C-5-OV*	9.0	8.0	6.8	5.3	150.
LXS-CC-5-OV*	16.0	14.5	12.7	10.5	200.
LXS-D-5-OV*	27.5	24.2	20.5	16.5	235.
LXS-E-5-OV*	35.0	30.0	24.0	17.5	300.
LXS-EE-5-OV*	45.0	39.0	32.0	25.0	425.
LXS-7-5-OV**	65.0	56.0	46.0	35.0	515.
LXS-8-5-OV**	85.0	77.0	68.0	56.0	650.

*Includes fixed overvoltage protection at 6.8V ±10%

**Built-in continuously adjustable overvoltage protection crowbars
output when trip level is exceeded. Included on all LXS-7, LXS-8 models

6 VOLTS ±5%

MODEL	MAX. AMPS AT AMBIENT OF:				PRICE
	40°C	50°C	60°C	71°C	
LXS-A-6	3.7	3.1	2.5	1.9	\$ 85.
LXS-B-6	5.5	4.7	3.8	2.9	125.
LXS-4-6	6.6	5.8	4.8	3.5	135.
LXS-C-6	8.8	7.8	6.7	5.2	150.
LXS-CC-6	15.2	13.8	12.1	10.0	200.
LXS-D-6	26.5	23.4	19.8	16.0	235.
LXS-E-6	34.0	29.0	23.0	16.5	300.
LXS-EE-6-OV**	42.0	36.0	30.0	22.0	425.
LXS-7-6-OV	59.0	50.0	41.0	32.0	515.
LXS-8-6-OV	70.0	70.0	68.0	56.0	560.

**Includes fixed overvoltage protection at 7.4V ±10%

12 VOLTS ±5%

MODEL	MAX. AMPS AT AMBIENT OF:				PRICE
	40°C	50°C	60°C	71°C	
LXS-A-12	2.7	2.2	1.8	1.5	\$ 85.
LXS-B-12	3.8	3.6	3.0	2.2	125.
LXS-4-12	4.4	3.8	3.1	2.5	135.
LXS-C-12	6.5	6.1	5.5	4.6	150.
LXS-CC-12	10.5	9.4	8.2	5.0	190.
LXS-D-12	16.0	14.0	11.9	8.0	235.
LXS-E-12	21.0	18.0	15.0	12.5	300.
LXS-EE-12	32.0	27.0	22.0	16.0	400.
LXS-7-12-OV	40.0	36.0	30.0	23.0	515.
LXS-8-12-OV	50.0	45.0	40.0	34.0	560.

15 VOLTS ±5%

MODEL	MAX. AMPS AT AMBIENT OF:				PRICE
	40°C	50°C	60°C	71°C	
LXS-A-15	2.4	2.0	1.6	1.3	\$ 85.
LXS-B-15	3.2	2.8	2.5	1.5	125.
LXS-4-15	4.0	3.5	2.8	2.3	135.
LXS-C-15	6.0	5.6	5.1	4.5	150.
LXS-CC-15	9.5	8.6	7.4	4.8	190.
LXS-D-15	14.0	12.3	10.4	7.5	235.
LXS-E-15	19.0	17.0	14.0	12.0	300.
LXS-EE-15	28.0	24.0	19.5	14.0	400.
LXS-7-15-OV	36.0	32.0	26.0	20.0	515.
LXS-8-15-OV	45.0	41.0	36.0	30.0	560.

LX-7 UP TO 28 VOLTS, UP TO AVAILABLE IN 68 MODELS

20 VOLTS $\pm 5\%$

MODEL	MAX. AMPS AT AMBIENT OF:				PRICE
	40°C	50°C	60°C	71°C	
LXS-CC-20	7.7	7.2	6.5	4.4	\$190.
LXS-D-20	11.5	10.2	8.6	6.8	235.
LXS-E-20	15.0	13.0	10.5	7.0	300.
LXS-EE-20	22.0	18.5	14.5	10.0	400.
LXS-7-20-OV	28.0	25.0	20.5	15.5	515.
LXS-8-20-OV	32.0	29.0	25.0	17.0	560.

24 VOLTS $\pm 5\%$

MODEL	MAX. AMPS AT AMBIENT OF:				PRICE
	40°C	50°C	60°C	71°C	
LXS-CC-24	6.8	6.4	5.7	4.4	\$190.
LXS-D-24	10.0	8.8	7.5	6.0	235.
LXS-E-24	13.0	11.0	9.5	6.0	300.
LXS-EE-24	19.0	16.5	13.0	9.5	400.
LXS-7-24-OV	25.0	22.0	18.0	14.0	515.
LXS-8-24-OV	30.0	27.0	23.5	17.0	560.

28 VOLTS $\pm 5\%$

MODEL	MAX. AMPS AT AMBIENT OF:				PRICE
	40°C	50°C	60°C	71°C	
LXS-CC-28	6.0	5.6	5.0	4.3	\$190.
LXS-D-28	9.0	8.0	6.8	5.5	235.
LXS-E-28	11.0	10.0	8.5	5.5	300.
LXS-EE-28	17.0	15.0	12.0	9.0	400.
LXS-7-28-OV	22.0	19.5	16.0	12.5	515.
LXS-8-28-OV	28.0	25.5	22.5	17.0	560.

± 15 TO ± 12 VOLTS DUAL OUTPUT

MODEL	ADJ. VOLT. RANGE VDC	MAX. AMPS AT AMBIENT OF:				PRICE
		40°C	50°C	60°C	71°C	
LXD-A-152	± 15	1.0	1.0	0.9	0.7	\$125.
	to ± 12	0.8	0.8	0.7	0.6	
LXD-B-152	± 15	1.6	1.4	1.2	0.7	150.
	to ± 12	1.4	1.3	1.1	0.6	
LXD-C-152	± 15	2.5	2.3	1.9	1.5	160.
	to ± 12	2.0	1.8	1.5	1.2	
LXD-CC-152	± 15	4.0	3.7	3.2	2.4	235.
	to ± 12	3.0	2.7	2.3	1.8	
LXD-D-152	± 15	6.2	5.6	4.9	4.0	280.
	to ± 12	4.5	4.1	3.7	3.0	
LXD-EE-152	± 15	12.5	11.0	9.0	7.0	435.
	to ± 12	10.0	9.0	7.8	6.0	

± 12 TO ± 15 VOLTS / -12 TO -15 VOLTS

MODEL	ADJ. VOLT. RANGE VDC	MAX. mA. AT AMBIENT OF:				PRICE
		40°C	50°C	60°C	71°C	
LXD-3-152	+(12 to 15)	400	370	340	300	\$85.
	-(12 to 15)	400	370	340	300	

± 6 TO ± 3 VOLTS

MODEL	ADJ. VOLT. RANGE VDC	MAX. AMPS AT AMBIENT OF:				PRICE
		40°C	50°C	60°C	71°C	
LXD-B-062	± 6	2.7	2.4	1.9	1.4	\$160.
	to ± 3	2.1	2.0	1.6	1.2	
LXD-C-062	± 6	3.5	3.3	2.7	1.7	\$170.
	to ± 3	2.6	2.4	1.9	1.3	

24 TO 30 VOLTS

MODEL	ADJ. VOLT. RANGE VDC	MAX. mA. AT AMBIENT OF:				PRICE
		40°C	50°C	60°C	71°C	
LXD-3-152	24-30	400	370	340	300	\$85.

5 VOLTS $\pm 5\%$, ± 15 TO ± 12 VOLTS TRIPLE OUTPUT

MODEL	ADJ. VOLT. RANGE VDC	MAX. AMPS AT AMBIENT OF:				PRICE
		40°C	50°C	60°C	71°C	
LXT-D-5152	5 $\pm 5\%$	12.0	11.5	11.0	9.5	\$375.
	± 15	3.1	2.7	2.2	1.7	
	to ± 12	2.3	2.0	1.7	1.3	
	± 12	2.3	2.0	1.7	1.3	

*5 volt output has fixed overvoltage protection at 6.8V $\pm 10\%$.
 ± 15 to ± 12 output is dual tracking output.

NEW LX-7 DESIGNED TO MEET MIL ENVIRONMENTAL SPECIFICATIONS.

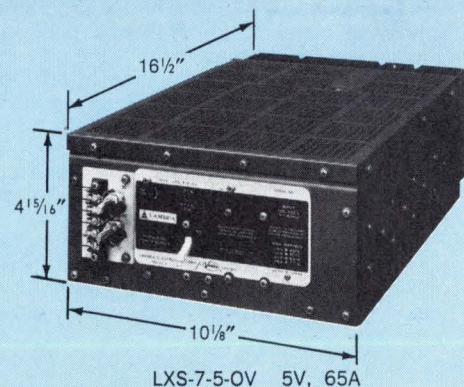

\$515

5-YEAR GUARANTEE

LAMBDA
ELECTRONICS CORP.

A  Company

515 BROAD HOLLOW ROAD, MELVILLE, L. I., NEW YORK 11746

THE FIRST OF THE BIG COUNT TIMERS

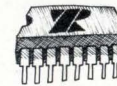
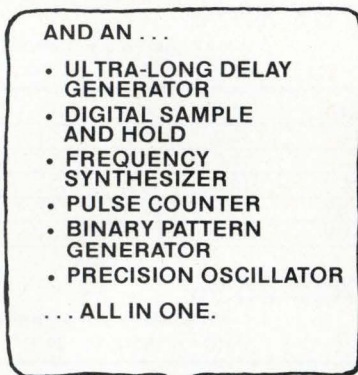
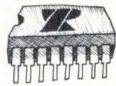
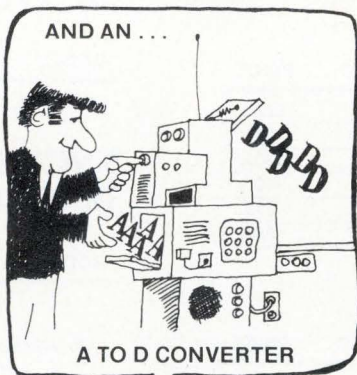
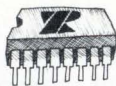
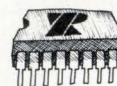
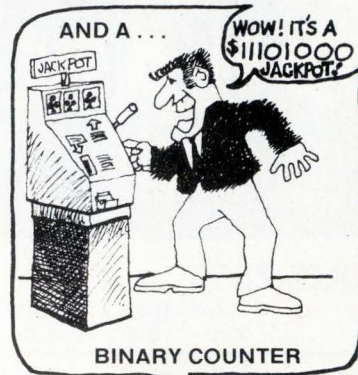
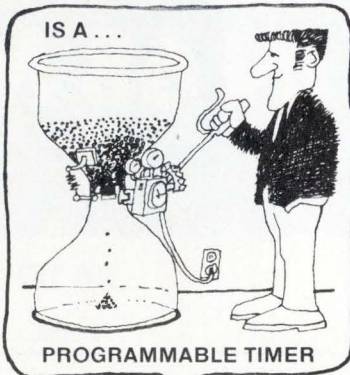
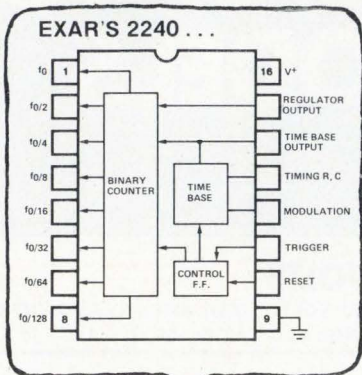

Exar's new XR-2240 counter/programmable timer solves so many tough problems that designers will unanimously agree that it's really the universal timer.

With its unique combination of analog and digital timing methods, you can now replace inadequate and complex assemblages of monolithic and electromechanical timers with the much simpler XR-2240. As a bonus, you get greater flexibility, precision operation, and a reduction in components and costs for most applications.

Because of built-in programmability, you can also use the XR-2240 for frequency synthesis, electronic music synthesis, digital sample and hold, A to D conversion, binary counting and pattern generation, and more.

With a single XR-2240 you can now generate pre-

cision time delays programmable from 1RC to 255RC, a range of microseconds to 5 days. By cascading only two XR-2240 timers, you can extend the maximum delay by a factor of 2^N , where $N = 16$ bits, resulting in a total delay of 3 years!

The XR-2240 operates over a 4V to 15V supply range with an accuracy of 0.5% and a 50 ppm/°C temperature stability. It's available in either a 16-pin ceramic or plastic dual-in-line package for military or commercial applications. Prices start at \$3.00 in 100 piece quantities.

For the more conventional timing applications, look to our other timers: the XR-220/230 timing circuit and the XR-2556 dual timers. Call or write Exar, the timer leader, for complete information.

EXAR SPEAKS YOUR LANGUAGE



EXAR INTEGRATED SYSTEMS

750 Palomar Sunnyvale, California 94086 (408) 732-7970 TWX 910-339-9233

EXAR DISTRIBUTORS Semiconductor Concepts: Woodland Hills: (213) 884-4560 Hauppauge, L. I.: (516) 273-1234 EEP Corporation: Culver City (213) 838-1912 Intermark Electronics: Sunnyvale: (408) 738-1111 San Diego: (714) 279-5200 Santa Ana: (714) 540-1322 Denver: (303) 963-8284 Seattle: (206) 767-3160 Graham Electronics: Indianapolis: (317) 634-8202 Lafayette: (317) 742-4006 Ft. Wayne: (219) 742-4346 Cincinnati: (513) 733-1661 Radio Electric Service Co.: Baltimore: (301) 823-0070 Gerber Electronics: Dedham: (617) 329-2400 Yankee Electronics Supply: Londonderry: (603) 625-9746

FCC's extra channel for MDS systems gets cool reception

New Federal Communications Commission rules, which create a second adjacent channel for Multipoint Distribution Service communications systems in the 50 largest cities, have disappointed equipment makers seeking expanded sales [*Electronics*, May 10, 1973, p. 65]. MDS is essentially a CCTV system, centered on a microwave transmitter with a 25-mile signal radius. **A second 6-megahertz channel adjacent to the first "isn't technically feasible . . . it won't spur the market,"** explains one manufacturer, because the second transmitter would have to be located next to the first and the interference and contractual problems would be enormous. Other makers add that it will drive up equipment costs and tend to perpetuate single-channel monopolies. The makers got some good news, however, because the commission allocated **a second 4-MHz channel to over 100 cities below the top 50**—an allocation that might create a digital MDS communications market.

Military oppose China getting helicopter avionics

U.S. military leaders are urging that any helicopters sold by American manufacturers to the People's Republic of China be stripped of all but the simplest avionics. The subject arose in mid-January with the confirmation that **United Aircraft Corp. has received Government approval to discuss the sale of an undisclosed number of its Sikorsky S-61N helicopters to China**, which wants to use them for patrolling its 4,000-mile-long border with Russia. **But Pentagon civilian leaders favor the sale**, because they believe it would be an effective counter to mounting Soviet forces along the China border. Moreover, one of them points out, China "undoubtedly knows as much as it cares about our helicopter hardware from what was salvaged in Southeast Asia."

Industry upset over new FAA delay of landing system

Among the companies competing for the national standard Interim Microwave Landing System—and also for a lucrative head start on a potential world market—exasperation reached a new high when the Federal Aviation Administration let it be known that it wants to rethink the much-delayed program yet again [*Electronics*, July 19, 1973, p. 42]. The agency first told companies it was going to decide soon, then flip-flopped and told industry sources that it **wanted to re-evaluate, partly because the candidate systems from Boeing, Singer-Kearfott, and Tull didn't totally meet requirements during flight tests at Richmond, Va., late last year.** Industry consensus is that the Tull system placed first during the flight tests, but that system prices might determine the eventual winner. The FAA would only confirm that the technical and economic packages haven't gone topside for determination.

Rules for disclosing corporate ownership may be stiffened

Legislation to stiffen Federal regulations on disclosure of stock ownership in publicly held companies, including aerospace, electronics, and communications firms, is being readied for introduction in the reconvened Congress by Sen. Lee Metcalf (D., Mont.) and Sen. Edmund Muskie (D., Me.). **The proposed tighter disclosure rules will seek principally to limit institutional investments concentrated in single or related industries.** The move was prompted by a Senate Government Operations subcommittee study, made public at year's end, which showed a high concentration of corporate stock ownership by large banks.

A spur for cable communications

Cable television and other innovative forms of cable communications have suffered slow growth. Like other significant developments, they seem destined to prove once more the truth of Max Planck's observation nearly 40 years ago that such advances "rarely make their way by gradually winning over and converting their opponents . . . what does happen is that their opponents gradually die out and the growing generation is familiarized with the idea from the beginning."

But now the acceptance and growth of cable systems may be accelerated with the completion and release this month of a 450-page White House report recommending a comprehensive national policy for cable. The product of 18 months of study by a special seven-man cabinet committee chaired by Clay T. Whitehead, director of the Office of Telecommunications Policy, the report is impressive. More important, it has managed to please most of the diverse groups with an interest in cable, despite its strong recommendations.

Separations of power

Of the dozen long-range policy recommendations, certainly the strongest is the one that calls for separate ownership of cable systems and program-supply services. That grates on cable operators the most, since they see no existing program-supply industry capable of satisfying the enormous appetite of a multi-channel system.

But the recommendation that has fascinated all of the report's early readers is the call for as little Government regulation of cable as possible. Specifically, the study recommends that "the Federal Government's authority over cable should be exercised initially to implement a national policy: thereafter, detailed Federal administrative supervision should be limited to setting certain technical standards for cable and applying anti-siphoning restrictions on professional sports programming."

Moreover, the document urges other prohibitions be adopted, including public utility-type rate-of-return regulation, grants of exclusive franchises by state or local governments, and the use of cable fees in general as revenue-raising devices.

Demonstration

With the possible exception of the recommendation on separate ownership of distribution and programming services—a temporary handicap at most—all of the recommendations should spur the growth of cable communi-

cations in this country. And one that is of particular interest to makers of the electronics hardware is the committee's proposal for a Federally supported demonstration program of the true potential of cable—a program that would last no more than five years.

The demonstration effort, larger than any thus far, could significantly speed the growth of cable systems—and the development of the multimillion dollar annual equipment market they represent. As the committee sees it, the project would be a way around the "chicken-and-egg problem hampering the development of many valuable services that might be commercially viable. The demand for these services depends heavily on their availability, yet few potential suppliers are willing to accept the risk of developing new services without significant evidence of a market demand . . ."

Uncertainties

Neither the Congress nor the Federal Communications Commission, which may be unhappy with the potential loss of its power over cable TV recommended by the report, has yet been heard from, for the report is still fresh and will require much internal analysis by both bodies. How they will respond is already a subject of speculation in the communications industry. Nevertheless, the committee cannot be faulted for failing to treat the realities of cable's challenge. Some are unhappy with its failure to deal with the nuts and bolts of regulatory problems. But such criticisms are largely quarrels with details of omission.

Whitehead and his committee did well overall, and they probably did so because they recognized from the outset that cable is not—as many of its early romantic advocates claimed—"a modern-day Rosetta stone capable of unravelling the complex problems facing this society." What they did do was "simply conclude that cable has much to offer, and it should be given an opportunity to prove its worth to the American people in the marketplace of goods and services and in the marketplace of ideas."

The biggest single problem with the report is not of the committee's making but concerns the White House. As the committee was structured in 1971, its product has now become a report to the President, not a report from him for appropriate congressional action. Thus there are questions about what President Nixon will do with it—if anything. These days there can be no question that it is not high on his list of priorities.

—Ray Connolly

Actual Size!

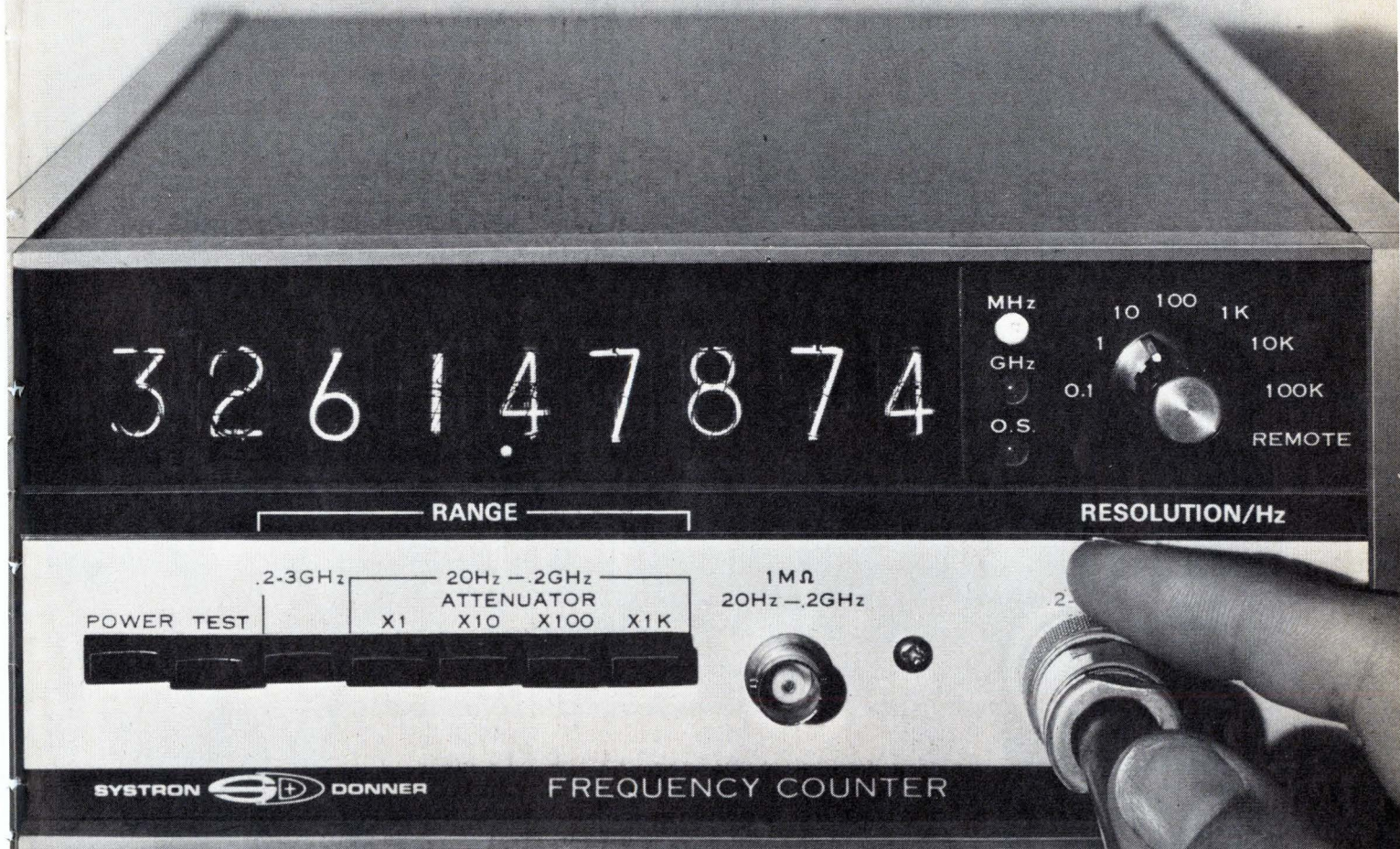

Fully automatic: DC to 3 GHz - \$2,295.

S-D's new 6053 counter:

Automatic operation, plus a new low sensitivity, high input impedance 200 MHz amplifier add up to one thing—a new high in counter performance. By automatic operation, we mean just that. All you do is hook up to either the BNC or "N" type connector and push the range button. It's really simpler than using an ordinary frequency meter!

Other key features and specs: 3½" half rack configuration. Resolves 3 GHz to 0.1 Hz. Remote programmable. BCD recorder output. 10 mV rms on 200 MHz input. Choice of 7 or 9 full digits.

The \$2,295 price comes out to only 77¢ per MHz! For that, why settle for 500 MHz, when the new S-D 6053 goes right up to 3 GHz?

Ask your local Scientific Devices office for complete data or a demonstration or contact: Concord Instruments Division, 888 Galindo St., Concord, CA 94520. Phone: (415) 682-6161. TWX: 910-481-9479.

SYSTRON  **DONNER**

Another S-D instrument first! Electronic counters/Digital voltmeters/Pulse generators/Data generators/Time code generators/Sweep generators/Spectrum analyzers/Digital panel meters/Digital clocks/Signal generators/Oscillators/Laboratory magnets/Precision power supplies/Analog & analog-hybrid computers/Data acquisition systems.

Circle 51 on reader service card

BOURNS® SPACE SAVER CERMET CONTROLS



ARE —

INTERCHANGEABLE WITH CTS 550 and 600 — Series 3852 is an exact CTS 550 replacement with less space required; Series 3859, ordered with a plastic bushing, also is interchangeable and costs even less. Series 3862 is interchangeable with the CTS 600 and is a better 1/2 inch diameter control.

THIN — Cut the bulk out of your new design... try the controls with the thinnest back-panel profiles in the industry — 1/4".

QUIET — CRV is conservatively specified at 3% of total resistance. Actually it's substantially less on most units.

CERMET — This provides the designer with BETTER STABILITY, HIGHER POWER-RATING, AND A ± 150 ppm/°C TEMPCO.

COMPETITIVELY PRICED

SERIES	100 piece quantity*	2000 piece quantity*
3852	\$1.56	\$.81
3859	1.27	.66
3862	2.20	1.18

AVAILABLE — All three Series, including their various shaft, bushing, and shaft-end styles, are stocked in-depth at each of 73 Bourns distributor locations. Delivery on standards is 24 hours.

LOOK AT THE SIGNIFICANT SPECS —

	MODEL 3852/3859	MODEL 3862
Power Rating	2 watts at 70°C	1 watt at 125°C
Temperature Coefficient	± 150 ppm/°C	± 150 ppm/°C
Diameter	3/4"	1/2"
Depth Behind Panel	1/4"	1/2"
Resistance Range	50 Ω to 5 megohms	100 Ω to 5 megohms
Resistance Tolerance	$\pm 10\%$	$\pm 10\%$
Bushing	metal and plastic, locking and non-locking, plus snap-in	metal; locking and non-locking

* Prices are U.S. Dollars, F.O.B., U.S.A.

FOR A COPY OF OUR COMPREHENSIVE 22-PAGE BROCHURE, OR TO ENTER YOUR ORDER, CONTACT YOUR LOCAL BOURNS SALES OFFICE, DISTRIBUTOR, OR THE FACTORY-DIRECT.



TRIMPOT PRODUCTS DIVISION • 1200 COLUMBIA AVE., RIVERSIDE, CALIF. 92507

Pocket slide rule packs many functions into 18 keys

Clive Sinclair, the Briton who proved that a four-function pocket calculator really could be lightweight, is now out to prove that a scientific calculator really can be cheap.

At the Chicago consumer electronics show (see p. 38), Sinclair's American subsidiary, Sinclair Radionics Inc., showed pre-production models of a pocket scientific machine that will be priced in Britain at 49 pounds, or about \$115.

The Sinclair Scientific is in the same case as the four-function Sinclair Cambridge—4.3 by 1.9 by 0.7 inches. It also uses a somewhat similar display module, although it reads out in an entirely different way. Its 18 keys include the 10 digit keys and the clear key. Four of the remaining keys each initiate three functions, giving 12 functions altogether. Keys 16 and 17 are modifiers to change the use of the function keys. Key 18 is used to enter an exponent of a number when one is being used.

Keys. Sinclair says that using one key for three functions is no snag and makes possible a real pocket scientific machine. The four keys initiate one arithmetic function and two other functions. Thus the "multiply" key, pressed without a modifier, simply multiplies. If one modifier is pressed before it, it becomes the "log" key. If the other modifier is pressed, it becomes the "antilog" key. The other functions, shared between the "add," "subtract," and "divide" keys, are sine, cosine, tangent, arc-sine, arc-cosine and arc-tangent. There's no constant key.

The LED readout looks superficially like an eight-digit LED strip with the sixth digit removed. The first five figures display the mantissa with the point fixed after the first digit. The last two are the exponent, expressed as powers of 10. Thus, the number 1 million will be displayed as 1.0000 in the mantissa and 06 in

the exponent. Both mantissa and exponent can be preceded by a minus sign on the display. The exponent range is from 10^{-99} to power 10^{99} .

Sinclair gets complexity at low cost by using a standard calculator chip with the read-only memory programed according to his own ideas. He won't say which chip he uses. However, it has 3,520 bits of read-only memory, and is 180 mils square. Sinclair worked out the algorithms for the transcendental functions, and the ROM was programed to realize them by Nigel

Searle of Sinclair Radionics Ltd. The display is driven by two new custom-designed bipolar chips, one of which also contains an up-converter that is part of the power supply to the main chip.

Searle says that most calculations will take about the same time on the Sinclair Scientific as they do on a Hewlett-Packard scientific machine. However, unlike the HP model, the Sinclair machine has no internal storage so that a number to be held over will probably have to be written down. □

Around the world

BBC develops its own digital-TV converter

Although the spread of digital techniques in television has spawned a number of analog-to-digital converters specifically designed to digitize video waveforms, the British Broadcasting Corp. was dissatisfied with those on the market and developed its own. BBC's Engineering Designs department, which built the converter, claims it's at least as good as any converter the BBC could buy and should cost much less if built in quantity. Russell Fletcher, the designer, estimates quantity-production cost at \$1,200 to \$1,600, which is about half the price of commercially available units. BBC will license interested commercial manufacturers.

The first application of the converter will be in a digital unit for converting 625-line television signals to 405-line signals. In Britain, 405-line TV sets, although no longer made, will be in use for many years. The BBC has to broadcast both signals, but for economic reasons, distribution from studio to transmitter is at 625 lines only. With present line-rate converters, which are analog, frequent adjustment are needed. The BBC believes the digital unit will only need no adjustment over long periods. Installation will start in the spring at a transmitter in North Wales.

West German study sees transmission upgrading

For the next 10 years, today's techniques will satisfy the growing demand for communications services in West Germany. Put another way, facsimile newspapers and the like are still a long way away. That's the gist of a study prepared by the ITT subsidiary, Standard Elektrik Lorenz AG, for the German postal administration. The 160-page report, revealed by board chairman Dieter Moehring, digs into what's economically justifiable rather than what's technically makable.

Moehring deems premature the speculations surrounding the so-called electronic newspaper and the video-telephone for private use. The same goes for new high-capacity transmission media like waveguides—either hollow, or in the form of glass fibers. "With glass-fiber techniques, particularly, there are many technical nuts to crack, which should take a good 10 years," Moehring says. No chance in this decade is given the "totally integrated communications network," which would provide TV programs, telephone services, teletypewriter messages, facsimile pictures, and various kinds of data from a central computer.

Open a Savings Account with our new megapower SCRs



When you invest in IR's new Megapower SCR Family Savings Plan you start earning dividends three important ways.

First, you can eliminate over 70% of the devices and parts normally needed (see the 3-phase converter "savings account" below for full details). That gives you a lower total system cost, plus more reliability.

Second, having fewer parts cuts assembly time sharply, increases reliability and makes your field servicing that much easier, too.

Third, Megapower SCRs give you more production power with only a minimum change in your equipment size.

If you want to parallel Megapower SCRs, there's a special bonus. Our epitaxial process

yields SCRs of virtually identical switching characteristics, so you eliminate expensive current balancing equipment. It also produces the high voltage SCRs you need. Specifically: 700A(av) 500 to 2100V; 850A(av), 500 to 2000V; 1000A(av), 500 to 1500V, and 1600A(av), 500 to 1200V.

IR'S 4800 Amp, 3-PHASE CONVERTER SAVINGS ACCOUNT

Parts Per Assembly	4800A Assy. Using 3-550A SCRs Per Leg	4800A Assy. Using 1-1600A SCR Per Leg	Parts Saved Per Assy.
1. SCRs	18	6	12
2. Heat Sinks	21	9	12
3. Clamps	18	6	12
4. Fuses	18	6	12
5. Balancing Reactors	18	0	18
6. Trigger Pulse Pwr. Amplifiers	6	0	6
7. Isolated Gate Drive Windings	18	6	12
Totals	117	33	84

There is also an extra dividend in overall productivity because Megapower SCRs will keep your equipment on line longer. Their surge capability is so high, they can ride through massive overloads without resorting to protective fuses.

Open a savings account today. Call your IR branch office, or bank headquarters (213) 678-6281; Telex: 67-4666. International Rectifier, 233 Kansas Street, El Segundo, CA.

International Rectifier

International Rectifier, 233 Kansas Street, El Segundo, CA 90245. ... *the innovative power people*



Britain's electronics companies surviving crisis—for now

So far, British electronics companies have fared better than expected under the law that restricts electricity offtake to about three-fifths of normal while the country's power stations are short of coal due to industrial disputes. By cutting down on lighting, electrical heating, elevator usage and so on—and starting up private emergency generators—**nearly all companies seem to be getting 90% or more of normal output.** Some even claim no reduction at all, although achieving full output by temporary stratagems, such as narrowing the product range.

However, it's doubtful how long this level can be maintained. **Many semiconductor makers are living hand-to-mouth for gases,** and equipment builders can see crippling shortages of plastics and steel as well as electronic components not far over the horizon. In fact, output of some TV set makers **is already more limited by component supply than power supply,** since most are working full time using standby generators.

Unidata machines start to be announced

Unidata is likely to follow up this month's announcement of its first brand-named computer with another larger unit later this year. The Unidata 7720—described as having 20% more performance than IBM's 370/15 at a System 3/15 price—is, in fact, a modified version of a medium-sized Philips machine that was already under development. It is still likely to be a matter of years before an entirely original design comes out of the joint research effort.

Nevertheless, between now and 1976 there will be several more Unidata-labelled computers. **While the first is being produced by Belgium's MBL, Siemens will be busy preparing the next new unit**—known for now as the X-1—as well as another, the X-3. The French partner, Compagnie Internationale pour l'Informatique will develop three others—X-2, X-4, and X-5. Meanwhile the struggle to decide how CII will fund its development goes on in France. And while the Pompidou government looks for an all-French solution, Honeywell-Bull is still maneuvering to join the Unidata club.

Pye's entry in British exchange market criticized

Moves by the British Post Office to increase competition among companies supplying it with telephone-exchange equipment by increasing their number have struck a snag. The three long established suppliers—Standard Telephones and Cables Ltd., General Electric Co. Ltd. and Plessey Co. Ltd.—make essentially the same equipment under cross licensing agreements **and are refusing to supply know-how on new electronic exchange techniques to the one newcomer the post office has approved so far, Pye TMC Ltd.** This prevents Pye, a Philips subsidiary, from getting started in development and production of the most important new types of exchange equipment. The post office's exchange equipment business is worth several hundred million dollars a year.

The three old hands argue that Pye's inclusion will have little effect on the public interest. Indeed it must work out excessively favorable to Pye and excessively unfavorable to themselves. There'll be no advantage in quicker equipment delivery, they say, because they have already more than enough capacity to meet post office schedules. Pye could charge lower prices, but only because no feasible license fee could equate with their large long-term investment in know-how.

Pye answers that the post office has approved it as a supplier, and it

has paid its entry ticket by making electromechanical equipment, so it should be let in. Pye also points out that dissolving a monopoly inevitably produces difficulties, but if it is in the public interest that the monopoly is dissolved, the difficulties must be accepted.

France's CNET making moves in electronic switching

The French government's telecommunications R&D organization—the Centre National d'Etudes des Télécommunications—is negotiating an electronic switching deal with the British Post Office. The talks are on establishing technical norms for interphases between the French Platon E10 technology and the British System-X project. **The objective is to permit the use of Platon-type switching gear in large transit exchanges in conjunction with British data-processing equipment.**

Back home, CNET is fast moving out of the experimental stage with its electronic switching networks. **Over the last few months, orders have gone out for enough E10 exchanges to provide 100,000 new lines** based on local exchanges in the western regional centers of Le Mans, Rouen, and Caen. The first of these networks will start operations soon in Le Mans and others will follow in 1975. In addition, CNET is due to put into service in Brittany this year a transit exchange, linking the local exchanges to the national network, and another large transit exchange in Paris—Les Tuileries—will be ready at the end of the year.

A third series of investments will be a string of regional control exchanges in western France. The first, in Rennes, will go into action in 1976. At the same time, transmission systems from the western area to within the western area and to Paris are being developed from a cabled system giving 50 megabits a second by next year to 140 megabits a second by 1978.

Nixdorf reports gains in its Japanese push

Although industry observers were skeptical at first, Nixdorf Computer AG has performed surprisingly well during the two and a half years that it's been active on the Japanese market. **In the computer class it represents—small systems and terminals—the German firm now claims an 8% market share in Japan,** and its 280 installations puts the company in the No. 3 spot behind Burroughs and NCR. The emphasis thus far has been on Nixdorf's 820/15 and 820/25 computer models. But lately, disk systems have come on strong also. In the U.S., too, the company says it's doing well. During the first year of activity there, it has done \$14 million worth of business, and the company now plans to increase the number of its U.S. outlets from 12 to 20.

Solar cells to recharge boat's batteries

By year's end, Ferranti Ltd. plans to be in production with a solar-cell array for recharging the batteries of pleasure boats. **An experimental array at the London Boat Show earlier this month attracted so much attention that the company believes it must sell well.** Production format will probably be about 30 circular cells, each 2¼ inches in diameter, arranged on a circular panel in a hermetically sealed case. Output will be about 0.5 ampere at 14 volts in bright sunlight. Life will be three years without degradation, and intended price is about \$500. **The company has made satellite cells for many years and its experts say the most difficult problem may turn out to be the casing,** which has to be transparent, waterproof, and boot proof as it will be part of the deck structure.



Fresh off the shelf. Ribbon cable from Hughes.

It could be as good an idea as penny candy: getting your ribbon cable from the same people who crack your tough flat conductor-cable problems.

We offer it by the foot, or as you like it. We not only make it, but we cheerfully cut it, strip it and terminate it for you.

Our new ribbon cable comes in widths from two to 100 conductors. The conductors are round (solid or stranded),

and have color-coded PVC insulation. You can get 22 to 28 AWG.

Of course, all our cable comes with Hughes quality built-in. And we handle your order with the helpful attitude of one of the most competitive companies in the cable business.

So write us soon. Hughes Connecting Devices, 500 Superior Ave., Newport Beach, Ca. 92663. Or call (714) 548-0671.



HUGHES

HUGHES AIRCRAFT COMPANY
CONNECTING DEVICES

We crack the tough ones. Circle 57 on reader service card

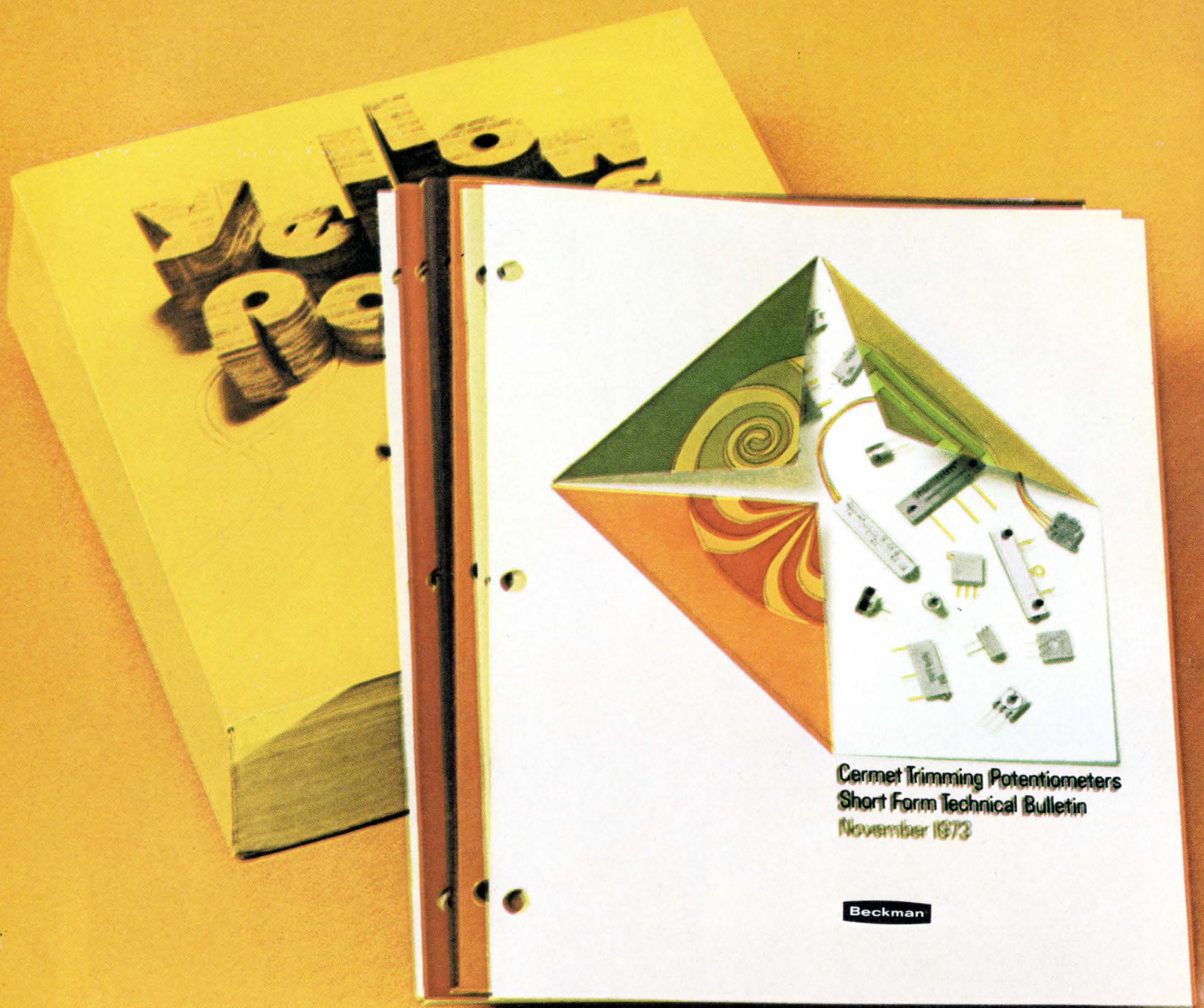

Cermet Trimming Potentiometers
Short Form Technical Bulletin
November 1973

Beckman

For the great mass of products and services, the yellow directory is your quick guide to local sources. Likewise, for precision potentiometers and trimmers – especially high-performance cermet types – the Beckman catalogs are your books. Broad standard lines, stocked for you by a nationwide network of dependable local distributors.

In precision pots, you'll find wirewound, cermet, single-turn and multiturn types ranging from 3 up to 40 turns. And, in size, the line goes from 40-turn master pot variety to units as small as 7/8" diameter.

Our cermet trimmers come in low-cost single-turn, multiturn, or DIP types. They typify our long experience and proven

control in materials technology. We develop, improve, and manufacture the materials in these highly stable trimmers. And they assure you wide resistance range, good high temperature/power characteristics, and complete moisture resistance. These are the trimmers for now and the future – their design advantages over wirewound types are many.

Look into our dials, too. The RB vernier-readout, for instance, with 100 graduations per turn. And the 2620, the perfect answer where position setting is a must but the budget permits less than highest precision.

For the complete reading on these Beckman components, ask your nearest distributor for applicable catalogs. They may become your favorite source books.

Find it fast in these standard reference books.

Beckman Electronic Component Distributors

EASTERN REGION

Arrow/Angus

P. O. Box 126
Moorestown, N.J.
(609) 235-1900
(215) 928-1800

Arrow Electronics, Inc.

5207 East Dr.
Baltimore, Md.
(202) 737-1700
(301) 247-5200

Arrow Electronics, Inc.

900 Route 110
Farmingdale, N.Y.
(516) 694-6800

Arrow Electronics, Inc.

295 Treadwell St.
Hamden, Conn.
(203) 248-3801

Arrow Electronics, Inc.

No. 15 A Street
Burlington, Mass.
(617) 273-0100

Arrow Electronics, Inc.

285 Midland Ave.
Saddle Brook, N.J.
(201) 797-5800

Harvey R & D Electronics

44 Hartwell Ave.
Lexington, Mass.
(617) 861-9200

Kierulff Electronics, Inc.

5 Industrial Dr.
Rutherford, N.J.
(201) 935-2120

Lynch-Gentry Associates, Inc.

1932 Drew Street
Clearwater, Fla.
(813) 443-2697

Lynch-Gentry Associates, Inc.

3470 Bowman Dr.
Winter Park, Fla.
(305) 671-7649

Marshall Industries

G. S. Marshall Products Group
88 Needham St.
Newton Highlands, Mass.
(617) 965-5115

M & C Sales

500 Plasamour Drive, N.E.
Atlanta, Ga.
(404) 875-2525

M & C Sales

1106 Burke St.
Winston-Salem, N.C.
(919) 723-1001

M & C Sales

904 Bob Wallace Ave.
Huntsville, Ala.
(205) 539-8476

Ossmann Component Sales Corp.

395 Cleveland Dr.
Buffalo, N.Y.
(716) 832-4271

Ossmann Component Sales Corp.

411 Washington Ave.
Kingston, N.Y.
(914) 338-5505

Ossmann Component Sales Corp.

280 Metro Park
Rochester, N.Y.
(716) 442-3290

Ossmann Component Sales Corp.

132 Pickard Building
Syracuse, N.Y.
(315) 454-4477

Ossmann Component Sales Corp.

1911 Vestal Parkway East
Vestal, N.Y.
(607) 785-9949

CENTRAL REGION

Magnuson Electronics

2420 Oakton St.
P. O. Box 130
Mount Prospect, Ill.
(312) 956-0700

Magnuson Electronics

1246 West 7th St.
St. Paul, Minn.
(612) 227-8495

Norvell Electronics

10210 Monroe Dr.
Dallas, Tex.
(214) 350-6771

Norvell Electronics

6440 Hillcroft Ave.
Houston, Tex.
(713) 774-2568

Norvell Electronics

3340 S. Memorial Dr.
Tulsa, Okla.
(918) 663-1247

Sheridan Sales Co.

Box 37826
Cincinnati, Ohio
(513) 761-5432

Sheridan Sales Co.

Box 4457
Cleveland, Ohio
(216) 524-8120

Sheridan Sales Co.

Box 423
Dayton, Ohio
(513) 277-8911

Sheridan Sales Co.

33708 Grand River Ave.
Farmington, Mich.
(313) 477-3800

Sheridan Sales Co.

P. O. Box 677
Florissant, Mo.
(314) 837-5200

Sheridan Sales Co.

Suite 5009
1717 Penn Ave.
Wilkesburg, Penn.
(412) 244-1640

WESTERN REGION

Almac/Stroum Electronics

8888 S.W. Canyon Rd.
Portland, Ore.
(503) 292-3534

Almac/Stroum Electronics

5811 Sixth Ave. South
Seattle, Wash.
(206) 763-2300

Barnhill Five, Inc.

1410-D Wyoming N.E.
Albuquerque, N.M.
(505) 299-7658

Barnhill Five, Inc.

1170 S. Sheridan Blvd.
Denver, Colo.
(303) 934-5505

Barnhill Five, Inc.

7329 E. Stetson Dr.
Scottsdale, Ariz.
(602) 947-7841

Marshall Industries

G. S. Marshall Products Group
9674 Telstar Ave.
El Monte, Ca.
(213) 686-0141

Marshall Industries

G. S. Marshall Products Group
8057 Raytheon Rd.
San Diego, Ca.
(714) 278-6350

Marshall Industries

G. S. Marshall Products Group
788 Palomar Ave.
Sunnyvale, Ca.
(408) 732-1100

Wyle Distribution Group:

Elmar Electronics

6777 East 50th Avenue
Commerce City, Colo.
(303) 287-9611

Elmar Electronics

2288 Charleston Road
Mt. View, Ca.
(415) 961-3611

Liberty Electronics

124 Maryland Street
El Segundo, Ca.
(213) 322-8100

Liberty Electronics

3130 North 27th Avenue
Phoenix, Ariz.
(602) 257-1272

Liberty Electronics

8248 Mercury Court
San Diego, Ca.
(714) 565-9171

Liberty Electronics

5305 Second Avenue South
Seattle, Wash.
(206) 763-8200

Beckman®

HELIPOT DIVISION

Circle 59 on reader service card

Centralab perspectives

FOR USERS OF ELECTRONIC COMPONENTS

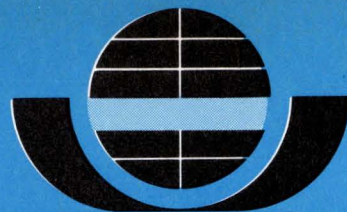

CENTRALAB

Electronics Division
GLOBE-UNION INC.

5757 NORTH GREEN BAY AVENUE
MILWAUKEE, WISCONSIN 53201

Now users of discrete capacitors are in the chips: Here's how we made it happen.

USCC/Centralab's evolution in productivity changed high-rel ceramic chip capacitors into economically realistic components for industry — including Detroit.

In 1966, U.S. Capacitor Corporation was a leading producer and innovator in the field of high-rel capacitors. We were capable of 140,000 chip starts a month. They were of highest quality for use on Apollo astronauts' portable life support systems.

USCC, a division of Centralab, is now the world's *largest producer* of chip capacitors. Today our automated production machinery and improved techniques allow us to start TWENTY TWO MILLION chips per month. But perhaps of even greater importance the yield of finished ceramic chips is of such high quality that they are now price competitive in an increasing number of commercial and industrial applications.

One system which USCC/Centralab engineers developed was converting the dielectric casting process from a manual operation to a machine-fed casting process. This new equipment is so effective that production rates increased 10 fold, while virtually eliminating material defects. In short — talent in production engineering.

Our new equipment allows us to produce chips for auto radios

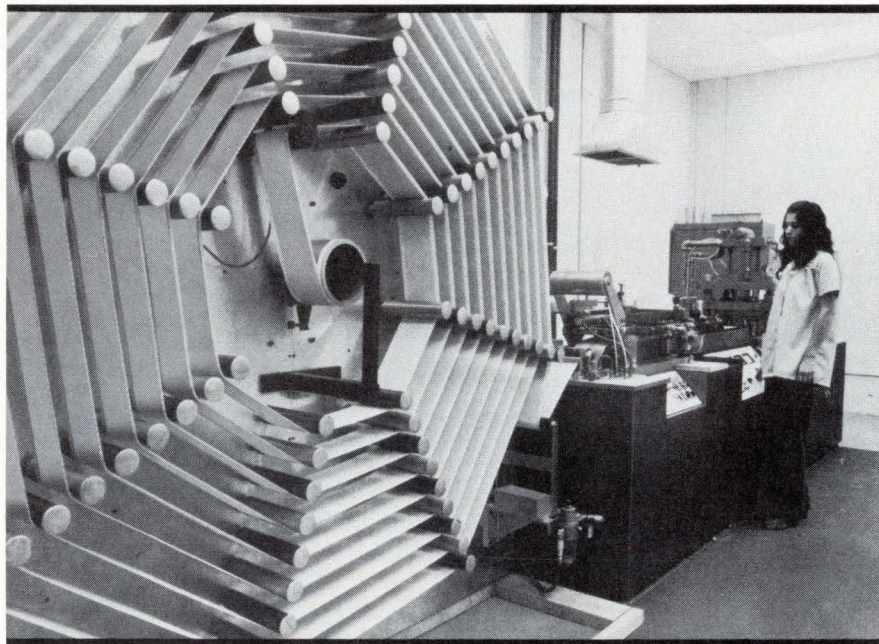

One of USCC's newest pieces of equipment which combines several operations previously done manually.

on the same production line as our high-rel units with no conflict between quality and fast delivery at reasonable prices. Our Detroit customer is now processing 25,000 auto radio circuits per day. We can keep him in the chips at the rate of 25,000 per hour.

Auto radios are only a small portion; ignition and fuel flow systems and voltage regulators are some of the new applications for an ever growing and demanding marketplace.

The same techniques that increased productivity also guaranteed utmost reliability so that

chip capacitors have evolved into a commercially practical product. If you're in the automotive business, the electronic OEM, if you make business machines or communications equipment, remember USCC/Centralab, the world's largest producer of reliable commercial ceramic chip capacitors.

Our engineering talent is available to help with your applications. Call John Vincent at USCC/Centralab (213) 843-3822.



USCC/Centralab
Electronics Division • Globe-Union, Inc.

2151 North Lincoln Street • Burbank, California 91504



Centralab perspective:

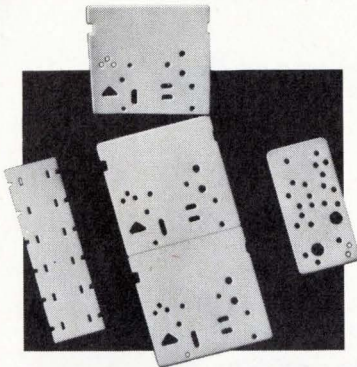

The next
best thing
to our plain
ceramic
substrates . . .

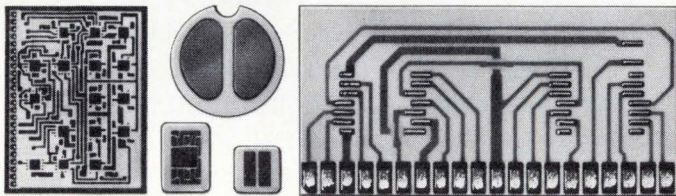

our metallized substrates

We can furnish high alumina substrates in any shape or size. With holes, notches, slots or scorelines — and with your choice of two metallizing systems:

- **Refractory metallization with high temperature molybdenum or tungsten** — for applications requiring bond strengths up to 14,000 psi. You get the pattern adhesion necessary for die or wire bonding, metallic seals, metal hardware or lead attachment. Plus excellent stability for high temperature processing in most types of atmospheres.

- **Noble metallization using silver, palladium silver or palladium gold** is ideal for conductive patterns in hybrid circuits. You can have complex patterns with 10 mil lines over large areas — 5 mils over small areas. Bond strengths meet requirements for subsequent soldering and/or die and wire bonding.

When you need proven metallized substrate capability come to Centralab — first. Our exclusive materials and proprietary production processes are the result of 45 years in ceramics for electronics. Put our technological skills to work for you.



Write
Centralab
for Bulletin
1057TC

Centralab perspective:

Pushbutton
switches.*
With 4 lockout
options.

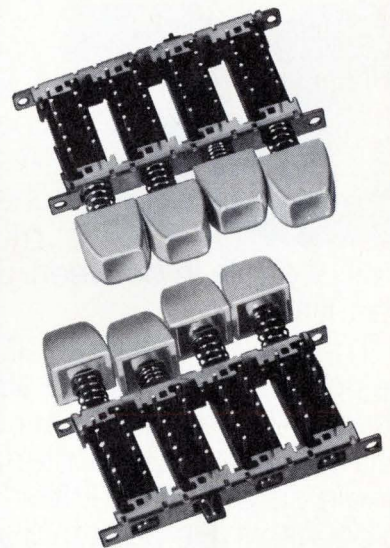

Centralab offers four lockout options for its momentary, push-push and interlocking action pushbutton switch modules. Lockout prevents actuating more than one switch at the same time — even if they're *not* adjacent. Another example of design flexibility. Other features include:

- 10, 12.5, 15, 17.5 and 20 mm spacing options.
- Epoxy sealed terminals.
- Modular LINE SWITCH — mounts in any station.
- 25 button styles and 18 colors.

Write Centralab for
Bulletin 1550.

*Isostat licensed

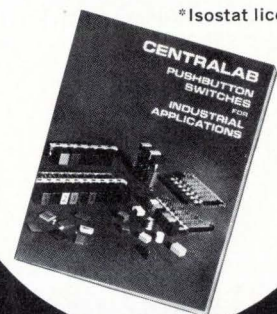

If you wanted to hook up a computer to a system that exercises electronic calculators, how would you do it?

Singer Business Machines did it simply, with Digital.



Computer on one end. Exerciser on the other. A single off-the-shelf module and

a bit of cable in between. Simple. Beautiful.

The project manager at Singer designed it. He'd heard about our new M1705 module that contained two complete PDP-8 interfaces on a single card. And he knew just what to do with it. He put it to work on his current project, a computerized testing system for Singer's electronic calculators.

Using our Logic System Design Handbook as a guide, he put together a parallel interface between the PDP-8/e computer and the electronic exerciser he'd designed. Each M1705 module interfaces two exercisers. The entire operation of up to eight exercisers is controlled locally by a single operation at 30 times the speed the operation took by hand.

The M1705 interface saved Singer's project manager a lot of time.

And a lot of trouble. And 40% of the cost of the interface.

If you've got an interfacing problem, we can give you the same kind of support we gave Singer. You'll find standard solutions to most of your problems in the Logic Products Handbook and the Logic Systems Design Handbook. To back up the solutions, we've got the hardware: digital and analog modules, computer interfacing modules, power supplies, cables, accessories, and wirewrap capabilities. Custom design assistance, too. And field specialists to offer advice if you get bogged down.

No one else can say nearly as much.

Which is why you'll probably want to get in touch with Digital next time you have an interfacing problem.

We're Digital Equipment Corporation, Logic Products Group, Maynard, Mass. 01754. (617) 897-5111, Extension 2785.

In Canada: P.O. Box 11500, Ottawa, Ontario, K2H 8K8. (613) 592-5111.

In Europe: 81 route de l'Aire, 1211 Geneva 26. Telephone: 42 79 50.

digital

We think interfacing is so important, we've devoted an entire department to it.

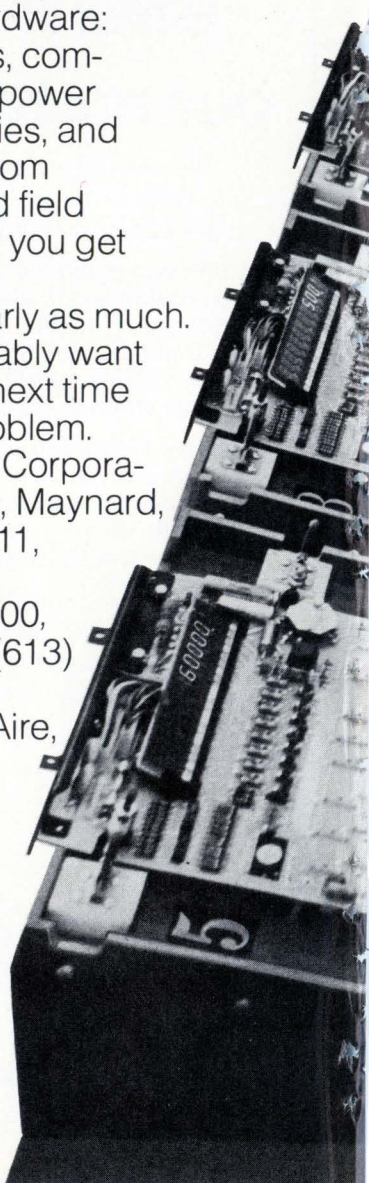

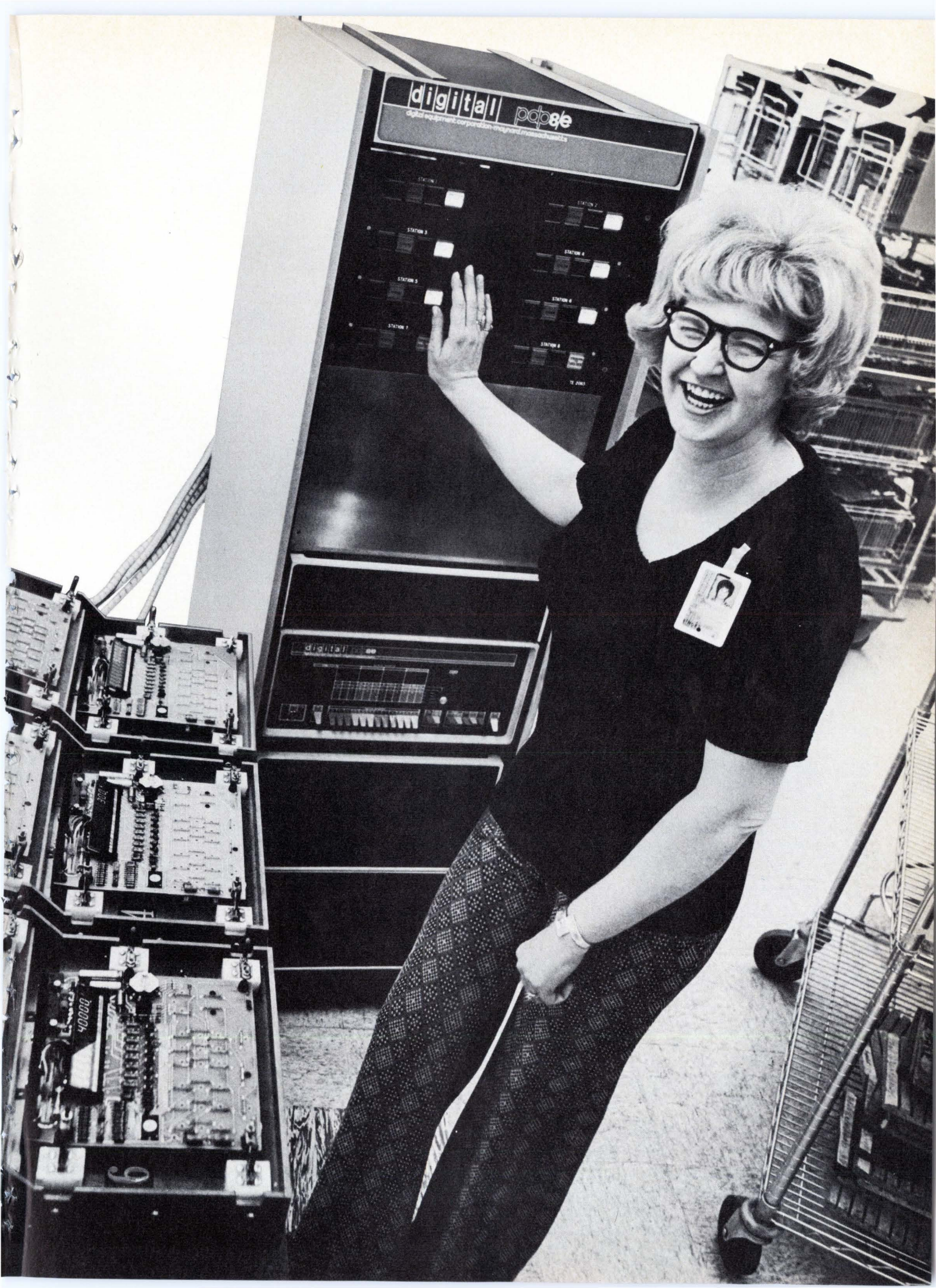



Piher components are going places

With our exports hitting an all time high in the first quarter of 1973 – particularly carbon film resistors and trimming potentiometers – we can rightly claim that our products are going places. They are going to every country in the world where the name Piher is synonymous with product excellence in the highly competitive component business.

It takes much more than a slick sales machine to build up one of Europe's biggest component companies. It takes total dedication to one end – ensuring that every customer knows that the Piher label stands for technical excellence.

And it does.

That's the major reason why we have grown to nearly 4,000 employees in six major plants achieving a \$50m annual turnover.

We design all our own production machines to ensure quality and reliability. We have no licence agreements, no subcontract working. From start to finish we are in control of every product that goes out to a customer. And we have a lot of customers.

We produce 8 million carbon film resistors a day to meet world demand – and we have the largest variety of quality preformed resistors available anywhere.

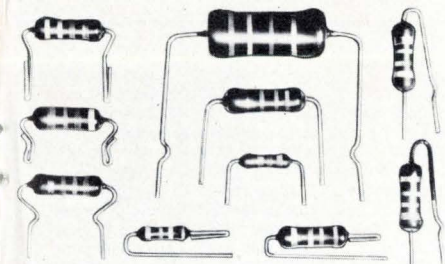

Piher output of carbon film resistors is a staggering 8 million a day.



Headquarters of Piher International in Barcelona. The company employs nearly 4,000 people in six major manufacturing centres throughout Spain.

We also provide the best range of quality, low-cost encapsulated trimmer pots – also slider and rotary versions – for every type of application, custom built to specific requirements where the need arises.

And that's only the beginning.

Our small signal and medium power transistor range is growing fast.

Our ferrites are in the forefront of magnetic ceramic technology.

And we have just laid down the most modern ceramic capacitor line in Europe. Apart from our six manufacturing centres we have a world-wide distribution network backed by five Piher companies in the USA, Germany, Great Britain, France and Italy. They are only a 'phone call away if you need details on the best components in the business.

Or write to us for data sheets on the product area you are interested in. Find out more about us. It pays.

U.K. – Piher International Ltd., Romar House, The Causeway, Staines, Middlesex, England.
Tel: Staines 56157. Telex 934167

U.S.A. – Piher International Corp. 1239 Rand Road, Des Plaines, Illinois 60016, U.S.A.
Tel: 312-297 1560. Telex 282154

Germany – Piher International GmbH, 85 Nuremberg, Westtorgraben, 5. Germany.
Tel: 0911 260 469. Telex 623354

France – Piher International SARL, 83 Rue Etienne Dolet, 94230, Cachan, France.
Tel: 656 26 07. Telex 27107

Italy – Piher International S.P.A. Via Cenisio 34, 20154 Milan, Italy.
Tel: 314532/316213

Head Office – Riera Cañado, s/n Apartado de Correos 53 Badalona (Barcelona) Spain.
Tel: 389 03 00. Telex 59521



FREE!

1974 Condensed Catalog Data Conversion Products

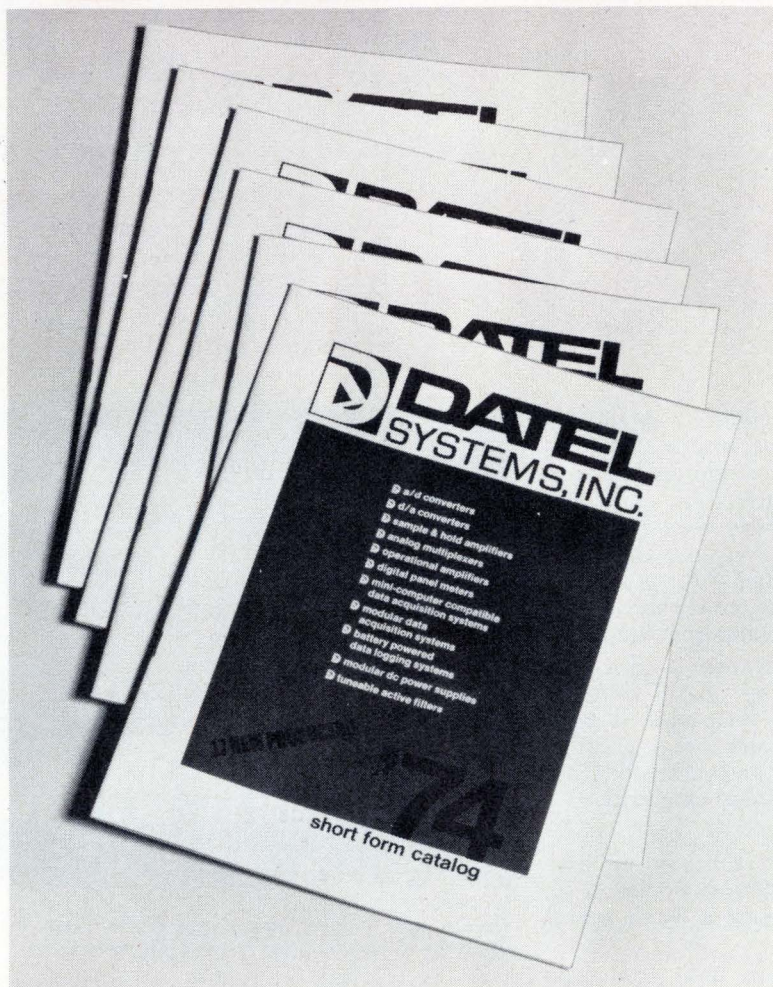

A new 40-page short form catalog contains 17 new data conversion products from Datel Systems. The catalog has complete electrical and mechanical specifications on all of Datel Systems products with over six pages of applications information.

Modular products described in this catalog include: A/D converters, D/A converters,

sample and hold amplifiers, operational amplifiers, DC power supplies, DC to DC converters, digital panel meters, analog multiflexers, active filters, voltage to frequency converters, and a 16 channel data acquisition system. Systems products include a 256 channel data

acquisition and distribution system with minicomputer interfacing for digital signal processing and a low power data logging system for remote environmental applications.



1020 Turnpike Street, Canton, Mass. 02021
• TEL. (617) 828-8000 • TELEX 924461
• TWX 710-348-0135

DATELEK SYSTEMS GMBH
8 Munchen 71, Becker-Gundahl-Strasse 1
W. Germany • Telefon 089/ 784045

FIELD SALES REPRESENTATIVES

(201)944-1600, Fort Lee, N.J.
(205)837-1601, Huntsville, Ala.
(206)285-2525, Seattle, Wash.
(213)476-2251, Los Angeles, Ca.
(214)231-9489, Richardson, Texas
(215)265-5211, King of Prussia, Pa.
(216)486-0782, Cleveland, O.
(303)427-5299, Westminster, Colo.
(305)943-3076, Lighthouse Pt., Fla.
(312)585-5485, Chicago, Ill.
(313)564-6325, Berkley, Mich.

(314)426-3656, St. Louis, Mo.
(315)622-2350, Liverpool, N.Y.
(317)293-0696, Indianapolis, Ind.
(319)377-6313, Marion, La.
(412)243-1111, Pittsburg, Pa.
(414)464-5555, Milwaukee, Wis.
(415)941-4080, Los Altos Hills, N.C.
(416)678-9241, Rexdale, Ont.
(505)281-5602, Sandia Park, N.Mex.
(513)294-2838, Dayton, O.
(514)389-8051, Montreal, Quebec

(612)544-9393, Minneapolis, Minn.
(613)237-6150, Ottawa, Ont.
(616)327-8390, Portage, Mich.
(703)522-6666, Arlington, Va.
(713)777-4477, Houston, Texas
(714)461-1033, San Diego, Ca.
(801)571-0129, Draper, Utah
(808)946-1533, Honolulu, Hawaii
(913)831-4259, Overland Park, Ks.
(918)622-0321, Tulsa, Oklahoma
(919)722-1783, Winston-Salem, N.C.

INTERNATIONAL SALES OFFICES: AUSTRIA & E. EUROPE/BACHER-TELE: 83 63 96 0 • GERMANY/DATELEK-TELE: 089/78 40 45 • ISRAEL/MTI-TELE: 242943
ITALY/3G-TELE: 544291 • JAPAN/FUSOH SHOJI-TELE: (580) 4015-7 or TAIYO SHOJI-TELE: (436) 3601-7 • NETHERLANDS/TECHMATION-TELE: 020-456955
SWEDEN/SVENSK-TELE: 08-91 04 40 • SWITZERLAND/INTERTEST-TELE: 031/224481 • LATIN AMERICA/CONSOLIDATED-TELE: (213) 397-6231

Probing the news

Analysis of technology and business developments

Need custom design? Do it yourself

That's what shortage of designers and heavy demand are forcing more and more semiconductor makers to tell users

by Paul Franson, Los Angeles bureau manager

If you think that the shortage of standard semiconductor parts is severe, try getting a new custom design out of a semiconductor house. Increasingly, the solid-state companies are telling customers to design their own. What has happened is that the reluctance of semiconductor houses to design and build small orders [*Electronics*, Jan. 10, p. 74] coupled with a chronic shortage of design engineers has forced many smaller-volume users to develop in-house design capability or farm the work out to moonlighters or design firms.

As for semiconductor firms, some have sought to manufacture other firms' designs for years and still are. Among them are Nitron Corp., Cupertino, Calif., known in the industry as a job-shop producer, and the Collins Radio Co. plant in Newport Beach, Calif., which has had plenty of excess capacity. But now, other big firms are soliciting this new business. MOS-producer American Microsystems Inc. in Santa Clara, Calif., is starting a formal program to get processing business, including publication of a new brochure entitled, "Do Your Own Thing—Then We'll Do Ours."

Fairchild Semiconductor of Mountain View, Calif., for one, has been doing it all along. A spokesman states, "We've noticed no increase in this type of business—but then we've always had quite a bit." Fairchild is now emphasizing standard chips, as National Semiconductor Corp., Santa Clara, Calif., always has. And both are devoting most engineering buildup to this side of the business, but not because they can't handle custom jobs. They get a better payoff for the engineer-

ing time and capital expenditure from standard parts. Neither of them—and for that matter, none of their competitors—turns down large potentially profitable custom jobs.

At Mostek Corp. in Carrollton, Texas, Gordon Hoffman, marketing director, says, "We do see a lot more requests to process supplied masks, but it's fraught with problems. If it's just to process and ship wafers it's easy; but if we have to package and test the devices it's difficult without an engineering guy in-house."

One semiconductor company that depends on custom parts and much customer involvement is Micro Power Systems Inc., Santa Clara, Calif. President John H. Hall, says that his company trains engineers of customers in IC design for periods that can last for months, so they understand the constraints of LSI technology. Among the projects Micro Power has handled is the Danameter digital volt-ohm-milliammeter for Dana Laboratories, Irvine,

Calif., [*Electronics*, Dec. 6, 1973, p. 99], and the new Analog Devices' 10-bit C-MOS digital-to-analog converter [*Electronics*, Dec. 6, 1973, p. 35]. Analog Devices engineers, who designed the d-a converter with support from Micro Power, have offices in the same Santa Clara building; Micro Power produces the chips.

Designers are scarce. The chronic shortage of designers—that's been the situation for at least two and a half years, says a spokesman at MOS-maker General Instrument Corp., Hicksville, N.Y.—has intensified recently, since many users want new custom-MOS parts for their products. This shortage has accelerated moves by users into designing, but some systems houses have been doing it all along for different reasons. Most computer and aerospace firms design at least some of the custom parts they require.

In Orlando, Fla., Martin-Marietta Corp. originally set up an IC-design and mask-making shop to retain de-

Do it yourself helper. One alternative for users of semiconductors faced with the need to do their own designs is to put in a design system. This is Macrodata's MD-180, for LSI design.



Probing the news

sign control over its parts, says Claude E. Jones, manager of the 145-engineer Microelectronics and Electronic Design Packaging department. Now, he says, the industry-wide shortage of designers makes the capability even more important because the company can handle its own chip designs, rather than having to rely on outside IC suppliers. The group uses a Macrodata design center for designing military and commercial communications products.

Tektronix Inc., of Beaverton, Ore., and Hewlett-Packard Co., of Palo Alto, Calif., also design many of their own parts. In fact, they help illustrate the trend toward complete integration—H-P has a substantial semiconductor capability, and Tektronix is moving in that direction through Amador Associates, Pioneer, Calif. And numerous computer houses have large IC facilities, including Burroughs Corp. in San Diego, Calif. Another firm with in-house design capability is Hycom Inc. of Santa Ana, Calif., backed by Japan's giant Sharp Corp.

Perhaps a unique example of why a user had to go on its own is General Automation Inc., which recently announced the first silicon-sapphire microcomputer. Larry Taylor, head of advanced development at the Anaheim, Calif., firm, points out that few semiconductor companies had expertise in the still-exotic high-speed technology, and the company felt it needed the proprietary parts to get the performance required. General Automation worked closely with the manufacturer, Rockwell Microelectronics, also in Anaheim, but says having a designer on the staff is vital for close communications. General Automation is working on even more-advanced SOS designs—it feels off-the-shelf parts are adequate for less-demanding SOS circuits.

Volume is key. Most of the companies setting up design facilities, however, aren't trying to make especially exotic parts, only products—especially large-scale MOS devices that yield performance and cost advantages. But the big IC producers aren't after that business unless the

quantities are high—100,000 per year and up. A big user, such as Digital Equipment Corp., Maynard, Mass., doesn't seem to have problems getting custom designs. But as Gene Jones, manager of project buying, points out, "The smaller firms with marginal requirements can't expect to get custom work—a designer will maximize the resources he has."

Cost factor. And then there's cost. Users report the going price for designing a fairly complex sophisticated chip can run \$30,000 to \$50,000 and it takes a whopping volume to amortize that amount. The cost of development is forcing many users that expect continuing requirements to consider alternatives carefully, since prices of automated-design systems start at about \$75,000, and they can also be used for circuit-board layout and conventional schematic drafting, as well.

It's generally agreed, though, that users aren't anxious to take on a whole new set of problems unless they see no reasonable alternative. "They're backing into it," says Don Bohrer, design system marketing manager at Macrodata Corp. in Woodland Hills, Calif. But products like Bohrer's illustrate the practicality of setting up a small design facility. "If the semiconductor firms can't find enough designers," asks one user, "where would we?" Consequently, virtually all user design groups have or expect to have some type of automated help.

Most seem to be opting for mask-making aids, such as systems from Applicon Inc., Burlington, Mass.; Systems, Science and Software, La Jolla, Calif.; or Calma Co., Sunnyvale, Calif. Ed Morton, regional sales manager at Calma, says turn-around times for automated equipment are typically five to 20 times faster than for manual systems, and, of course, a mechanical system eliminates the need for many draftsmen. General Automation uses its own in-house system built around one of its own minicomputers.

Some firms pick more comprehensive and expensive systems—as high as \$120,000 to \$130,000—such as the new Macrodata Midas (for Macrodata interactive-design-aid system). Unlike the systems oriented to engineering-drafting, it identifies

the basic circuit elements, not merely geometrical shapes. This permits extensive logic-simulation, design-rule checks, and nodal analysis, but some work must be done on an external large computer. Although big semiconductor firms often prefer hand-layout for highest density, this isn't a vital factor for smaller-volume customers.

Of course, since a design system—even a comprehensive one—doesn't design MOS LSI by itself, the usual route is for users to either pirate people from the semiconductor industry or try to develop the desired skills in company personnel. Integrated Circuit Engineering in Phoenix, Ariz., conducts seminars for this purpose, and seminar manager Howard Dicken reports greatly increased interest in multiweek sessions that acquaint engineers with IC-design techniques. The IC courses are built around practical designs that interest students.

Dicken, like others, recommends sticking to proven, well-standardized processes—p-channel MOS, bipolar, and C-MOS.

Like any new effort, many users can expect to stumble a bit with semiconductor designs, and many have, instead, turned to design services and moonlighters. There are also service bureaus such as Computer Drafting Inc. of Pennsauken, N.J., which translate circuits into finished drawings and rubyliths for processing.

But design services and moonlighting engineers may not come cheap. Gene Potter, president of a semiconductor-design firm, Silicon Systems Inc. of Santa Ana, Calif., warns that custom designs for smaller users (1,000 to 20,000 ICs) must make dramatic improvements in size, performance, and cost of systems.

If it all sounds a little discouraging to users, the answer for many must be standard parts and microprocessors, programable-logic arrays, and other parts for which the user takes on much of the design burden. Unfortunately, the delivery situation and immaturity of the products suggest that equipment and systems houses will have to choose carefully between custom devices and less satisfactory alternatives. □

When you need a custom high voltage power supply, ELDEC designs, packages, and builds them so you can rely on them.

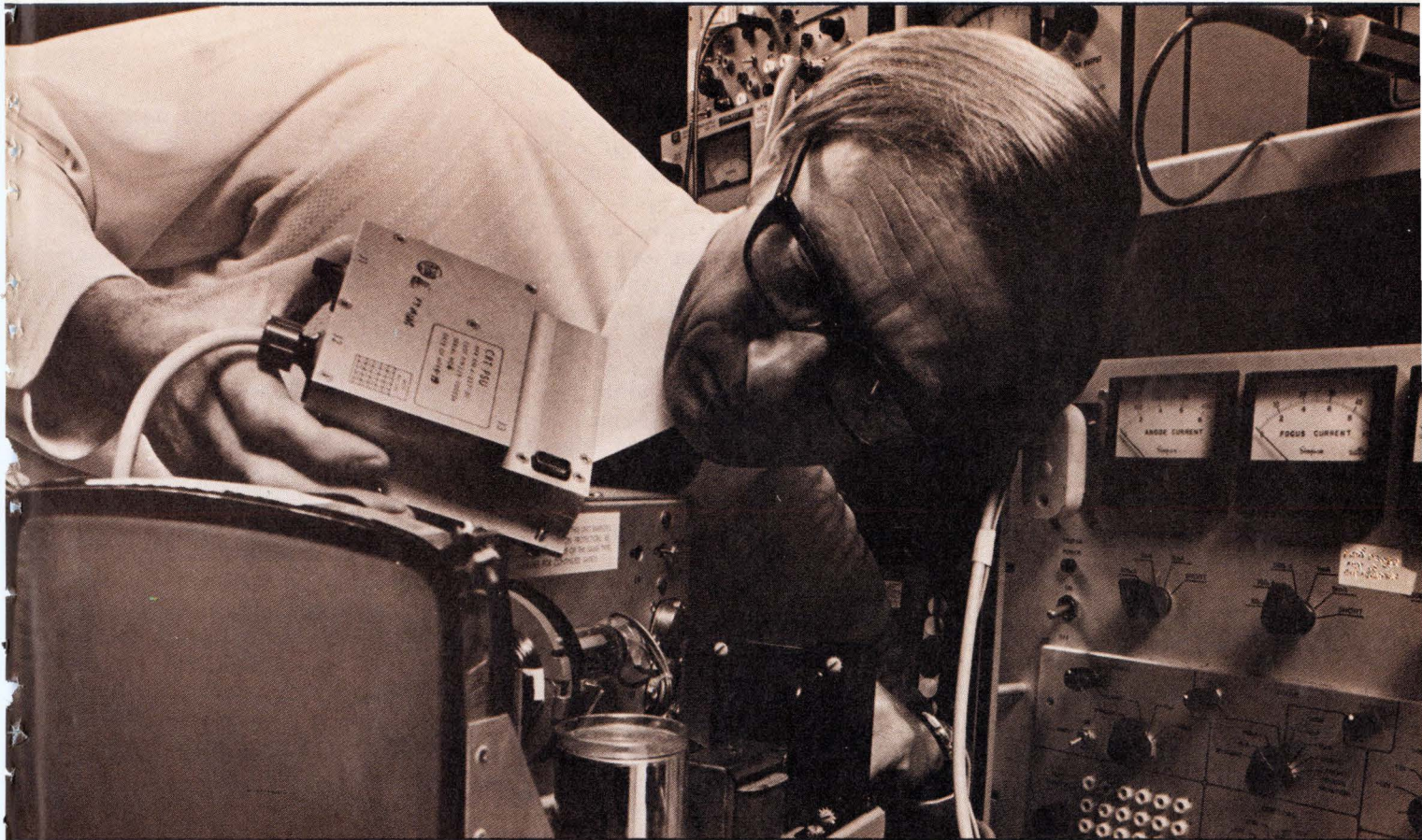

Power supplies for CRT displays. Small size. Light weight. Look to ELDEC. We have years of experience combined with field proven reliability. ELDEC specializes in high voltage, custom mil-spec requirements. Air, ground, or shipboard.

Now by-pass that make or buy decision. When reliability is on the line, rely on proven experience. And ELDEC delivers. No gap between promises and prototype. High quality levels of manufacturing? You can bet on it!

We understand the custom business. Plenty of back-up documentation and service support. A successful track record you can check on. Ask for our brochure. Write me, Kevin Hall, Marketing Manager, ELDEC Corporation, 16700 - 13th Ave. W., Lynnwood, Washington 98036. Phone (206) 743-1313.



Formerly Electro Development Corporation

Consumer electronics

TV makers under the gun

Upcoming Consumer Product Safety Commission hearings leave executives worried, skeptical, and just a bit nervous

by William F. Arnold, Aerospace Editor

Amid their talk of the effects on sales of America's latest set of crises, television-set manufacturers were abuzz with another big concern at this month's Winter Consumer Electronics Show in Chicago: The alarming news that the issue of safety of TV sets is back again as big as ever, and that it appears likely to lead to tougher Federal safety standards, for makers to hew to.

The cause of their concern is a February meeting by the relatively new Consumer Product Safety Commission (CPSC), which intends to call in set makers and other interested parties for hearings on safety [*Electronics*, Jan. 10, p. 53].

The executives are worried that the commission not only wants to talk about possible fire hazards, but is also likely to question shock hazards, quality control, design details, and manufacturing techniques. Manufacturers also will be asked to propose safety measures that should be instituted in their receivers but haven't been.

Beyond '69 panel. Thus, the commission is carrying the scope of the proceedings far beyond the 1969 hearings by another Government panel, which generated a set of voluntary industry standards—standards the get-tough commission doesn't seem to think are working.

Manufacturers are noticeably reticent when it comes to commenting on the confusion surrounding the commission's actions to date, but fear of the unknown seems to sum up the reactions.

"I don't know how much of this is politics," says one industry official, "but whatever the motivations are, it's scary."

Under the law, the commission

has the power to impose standards ("Consumer safety with a punch," p. 71). And its chairman, Richard O. Simpson, indicates it will (see p. 14). The most widely publicized of its data concerning set safety is the commission's 916 "home television-related fires" caused several injuries and one death within a year in a sample population of 21.7 million persons across the country.

That number leaves many manufacturers cold, however. They question the degree of involvement of TV sets, the quality of the data, the way it was collected, and whether or not it represents a hazard.

"If you project that number na-

tionwide [to include possible unreported incidents], and take out our sets," says one manufacturer, "it's still larger by orders of magnitude than our information." Another industry official says that he has initiated a search for some of the incidents involving his sets. "We have no claims on file—for product, for damages, or for injury—for some of the incidents cited involving our product."

'Scare tactics' scored. The industry also is burned up by the commission's use of headline-generation and what they call "scare tactics." Says one company official: "The commission, on one hand, has made statements that its purpose is altruistic—to help the consumer. On the other hand, Simpson has said that he just can't wait to convict his first officer of a major corporation. All of us in the industry, of course, are keeping a low profile."

But Simpson declares that it was the TV manufacturers' own data that aroused the commission's interest in the safety issue and caused it to investigate further and produce the 916 figure. Under Section 15 (B) of the stiff consumer Product Safety Act, manufacturers are required to voluntarily report safety defects, he explains. Within the first year, there were "well over 100,000 different sets with defects in them, such as to cause a substantial product hazard." Simpson notes that only U.S. sets are involved, even though all manufacturers and importers are required to report.

Other numbers. Commission data, he says, shows that Philco-Ford had 9,000 sets with fire hazards; Zenith, 22,000 fire and shock; Admiral 4,200, shock; Montgomery, Ward,

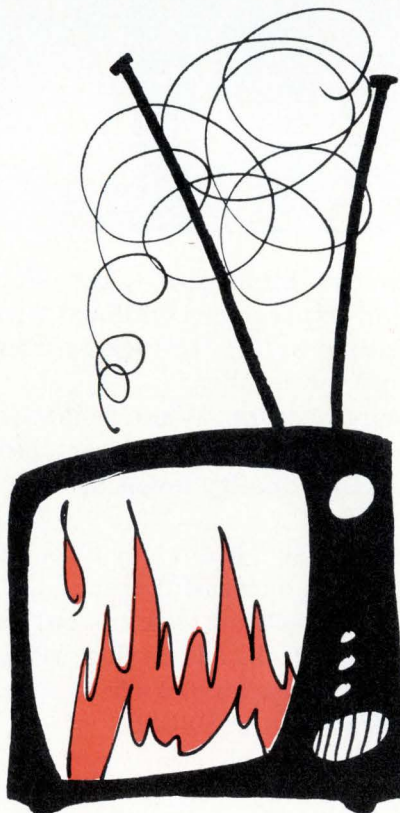

52,000, shock; and Packard-Bell, 6,800, shock.

Makes in the 916 total include RCA, Magnavox, Sears, Sharp, Sony, Panasonic, and Heath. Consequently, TV-set safety was moved near the top of the commission's list, Simpson says.

Information, please. Although next month's hearings will emphasize TV-related fires and shocks, the commission also will probe TV-tube implosions and antennas. It has asked set makers, component makers, and standards organizations to provide a host of information, according to the draft document. For example, each set maker is requested to submit all accident-report data collected since the 1969 hearings that were conducted by the National Commission on Product Safety.

In addition, the commission wants to know what makers are doing about safety standards and quality control, what they have planned, when it will be implemented, and what they might suggest that would be even better. Also, witnesses are supposed to tell how they might handle service technicians and improvement plans for TVs currently in use.

Moreover, the commission is curious about standards and accidents in four manufacturing trends on techniques—for protection against over heating, direct ac-to-dc chassis design, compact portable receivers and those with thermoplastic enclosures, and methods for minimizing dielectric stress on chassis components.

Year away. It would take at least a year for any Federal standards to be set even if the commission decides to impose them, Simpson says. He hastens to explain that, under the law, the manufacturers are part of the standards-writing process and will have ample opportunity to influence any standards. But, as comforting as that may be, the commission seemingly has the power to legislate design of TV sets as well as safety.

Simpson downplays the ominous aspects of the commission's powers by saying that it operates in a goldfish bowl. "All meetings of any significance at all with any member of the commission or staff member is

Consumer safety with a punch

"We mean business, and I think it is important that you understand that fact," declares Richard O. Simpson, chairman of the Consumer Product Safety Commission (CPSC), in a series of speeches across the country. Although Simpson says that he would rather have company executives' cooperation than put them in jail, he also says that he's "personally inclined" to include heads of companies in criminal indictments for violations "because I believe they are in the best position to assure corporate compliance with CPSC regulations."

Sometimes called the only Government agency that Ralph Nader likes, CPSC was born last May from the Consumer Product Safety Act and endowed with an awesome set of powers. Aside from the issue of TV-set safety, however, its influence on the electronics industry is conjectural at this point because many aspects of electronics safety are watched by other agencies, such as the Bureau of Radiological Health for radiation and the Federal Aviation Agency for civilian avionics.

But the commission can: ban a product from the market if it concludes the product presents an unreasonable risk and that no feasible standard would protect the public, ask a court for immediate seizure of a product if imminent personal danger exists, force a company to mail a notice of the product's defectiveness to every purchaser, and require companies to let the commission know in advance of new products. It requires companies to voluntarily report safety defects to it. Penalties are stiff: \$2,000 to \$500,000 for each civil violation, as well as a maximum of a year in prison and \$50,000 for each willful criminal violation.

open to anybody in the U.S.," he says. "There are no closed-door sessions." He adds that the CPSC has even published a list of potentially hazardous products, ranking them from worst to least, and announced that it was essentially going to proceed from the top. CPSC has \$31 million and 700 employees for fiscal 1974 and seeks \$42.1 million and a 1,000-employee level for the fiscal year of 1974-75.

Standards coming. Industry believes that CPSC probably will legislate standards. "I feel that so long as the standard is a reasonable one—allowing the manufacturers flexibility from a design standpoint—it's probably one that we could live with," says the consumer-affairs manager for a major TV producer. "But if standards are too rigid, they could adversely affect innovation."

Some manufacturers, in fact, think that some new standards would be a good idea. "If this is an attempt to update the 1969 EIA ad hoc committee standards, we're interested," says one. "Because of antitrust considerations," he points out, "it's difficult to get together for things like this, except under Government aegis."

But the commission apparently isn't looking for a diluted group position. "I don't think they will listen

to EIA; they will throw them out," one manufacturer says.

Follow companies. Instead, Simpson is hoping to draw out the individual companies' engineering standards—always more stringent than committee standards, he says. Then, after soliciting these voluntary standards, the commission will take them over and attempt to make them mandatory.

J. Edward Day, special counsel for the Electronic Industries Association, comments that, since industry is "doing everything we know how," if the commission has a better way, "it should be brought about." Armin Allen, Philco-Ford vice president for consumer affairs, and Yutaka Yamada, U.S. product safety manager for Panasonic, agree that hearings could improve product safety. However, Allen cautions that he hopes the commission realizes that implementing new standards could push up the price of sets, and he views any changes in that light.

Considering the fierce competition in the television industry where an advantage can be measured in the \$5 or \$10 less a set might cost—and any increase in what it costs to make a set can be multiplied tenfold by the time that set reaches the consumer—such changes could be worrisome indeed. □

Solid state

Nitride makes its mark

Designers borrow MNOS technique to turn out memories that are reprogrammable and nonvolatile

by John Gosch, Frankfurt bureau

Although the promise of nitride-doped MOS devices (MNOS) has yet to be realized in the form of MNOS products, nitride technology is finding its way into an assortment of devices. What semiconductor designers are doing is taking advantage of the reprogrammable and nonvolatile properties of the technology in conjunction with well established product technology.

For example, researchers at Westinghouse Electric Corp.'s Defense and Space Center in Baltimore have teamed MNOS transistors with charge-coupled delay lines to form a fully programable transversal filter for radar. At the same time, other Westinghouse workers have applied MNOS memories to a remote, automatic electric-meter-reading system to protect it from power interruptions. And at Litton Industries, which was an early MNOS developer, work is proceeding on reprogrammable memories for airborne computers.

Nonvolatile team. One of the latest and more unusual nitride applications has emerged from the Munich, West Germany, labs of Siemens AG. There, to overcome the major problem of volatility of semiconductor random-access memories, charge-coupled serial shift registers have been combined with nitride MOS capacitors on the same chip. This combination results in a memory circuit that retains its information virtually indefinitely.

The device achieves its nonvolatility by transferring the information from the CCD to the MNOS capacitor where it is stored. This type of permanent memory may be useful in such systems as telephone switching or in process control where the high

packing density offered by CCDs and long information-retention times of MNOS capacitors are called for, says Karl Goser who heads the development effort at Siemens.

The experimental device has its MNOS storage capacitors connected to a common address line. Each capacitor electrode goes to a CCD electrode of the same phase line. Both the MNOS capacitors and the CCD are made of aluminum, silicon-nitride, and silicon-oxide layers, all on top of a silicon substrate with a 10 ohm-centimeter resistivity. To enhance the transfer characteristics of the p-channel CCD, the 6-micrometer-wide gaps between its electrodes are implanted with boron. The test circuit packs a 13-electrode CCD and three MNOS capacitors onto an area of about 350 by 1,000 micrometers.

The information is transferred from the CCD to the capacitor and vice versa—the write and read cycles—by shifting the threshold voltages of the two elements. These voltage shifts result from a charge-

carrier transfer, a principle also used in conventional CCDs.

The operating range for the device must be chosen so that there is a large threshold-voltage shift when the field is high and no shift when it is low. Thus, the charges of the MNOS capacitors can be stored by simply shifting the threshold voltage. The shift occurs in a few microseconds, and only a negligible amount of positive carriers is produced in the depletion region.

Reading. To read, a voltage applied to the address line sets up a depletion region in an MNOS capacitor with a high negative threshold voltage. The inversion-layer formation, Goser says, can be speeded up by using not only the carriers produced by thermic generation but also those coming from the CCD. The charge in the inversion layers is transferred from the MNOS capacitors back to the CCD by using a high phase voltage at the CCD electrodes and by simultaneously lowering the voltage at the address line. □

Semiconductors close in on analog signals

The prospect of applying semiconductor technology to analog signal processing has been brought a step closer by marrying charge-coupled and MNOS devices. At Westinghouse Electric Corp., MNOS devices are built onto the taps of a CCD delay line to make a fully programable transversal filter, the basic building block in a discrete analog signal-processing system such as chirp radar.

Stated most simply, the MNOS transistor allows a designer to change the conductivity and hence the quantity of the charge that's available at any of the taps so that he may match the desired signal amplitude at each tap to a particular code. These delay lines can be matched to perform an entire array of signal-processing applications, including Fourier transformers, matched filters and correlators, and adaptive filters.

The nitride permits the designer to reprogram electrically the tap weights in his delay line. An alternative would be to change the mask in order to change the weight of the taps.

RCA COS/MOS in low cost ceramic.

RCA now offers COS/MOS in a new low cost ceramic package. So you can select, from our complete line of COS/MOS circuits, an IC package to meet your exact needs for performance and price.

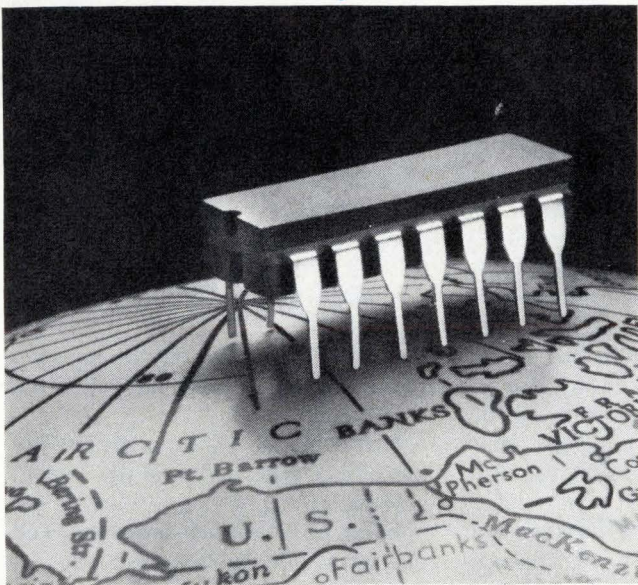

Our new CD4000AF Ceramic IC's feature electrical characteristics identical to the present AD and AK series weld seal ceramic COS/MOS circuits. You get a completely hermetic package designed to operate over the full military temperature range of -55°C to $+125^{\circ}\text{C}$... at a commercial price.

Compare the prices of our new ceramic IC's. If you've needed the temperature range and hermetic features of ceramic, but couldn't afford

TYPE NO.	FUNCTION	AF PRICE (1000+)
CD4001AF	Quad 2-input NOR gate	\$.98
CD4011AF	Quad 2-input NAND gate	.98
CD4013AF	Dual "D" master-slave Flip-Flop	2.03
CD4020AF	14-stage binary/ripple counter	5.90
CD4027AF	Dual J-K master-slave Flip-Flop	3.14
CD4029AF	Presetable up/down counter	7.94
CD4042AF	Quad clocked "D" latch	4.23
CD4046AF	Micropower phase- locked loop	5.63
CD4047AF	Monostable/Astable multivibrator	3.75

the price, now you can discover the digital world of COS/MOS in RCA's new low cost ceramic package.

Our complete new line of COS/MOS CD4000AF Series Ceramic IC's, in 14-lead or 16-lead dual-in-line packages, are available at your local distributor. Or you can order them direct from RCA.

For complete pricing and data sheet write: RCA Solid State, Section 70A-24, Box 3200, Somerville, N. J. 08876. Or phone: (201) 722-3200.

RCA Solid
State
products that make products pay off

Computers

Calculator is almost a computer

Hewlett-Packard's HP-65, to sell for \$795, permits users to write their own programs on magnetic cards or use prerecorded ones from H-P

One hand-held computer per person—that dream has come closer to a waking reality with Hewlett-Packard Co.'s introduction of its fully programmable HP-65 calculator. It should appeal initially to those deterred by the high cost or complexity of programing equipment. Now they write their own on blanks of the magnetic cards that control the new machine. Other cards are supplied already recorded with programs in a variety of fields—from mathematics to navigation to electronic engineering.

Development of the HP-65 took two years and drew upon all of H-P's resources. It will be sold by mail, in bookstores, and through H-P's own sales organization for \$795. With it comes one set of prerecorded programs. Each additional "pac"—Hewlett-Packard drops the "k"—will cost an additional \$45. The company also plans to start a users' li-

brary to which programs can be sent for testing. An interesting feature is the pair of diagnostic cards to be supplied with the sample program pack, probably the first time a pocket-size calculator has been made self-testable.

There is at least one other hand-held programmable calculator on the market, the model 324 made by Compucorp in Los Angeles, but it is larger than Hewlett-Packard's and operates in what is commonly known as the "learn mode." That is, it allows only for manual program entry and must be reprogrammed each time the power is turned off and then on. Also, it sells for \$895.

Fred I. Sommer, a member of the Advanced Products division's marketing staff, says H-P has no plans to tack peripherals onto the new calculator. That's what the desktop machines, including the low-cost model introduced in June [*Electronics*,

June 7, 1973, p. 42], are designed for. The model 65, says Sommer, was developed to satisfy the demand for easily used, personal computing power in portable form. He predicts the new machine will help sell more desktop models because so many of its users will become familiar with the advantages of programing that they'll upgrade to machines with increased programing capacity like H-P's 9820 or 9830.

Starting behind. In any event, the 65 will have a long way to go to catch up with sales of Hewlett-Packard's HP-35 and HP-45 electronic slide rules and the HP-80 business calculator. Combined sales now top 300,000 machines.

However, the HP-65 meets two of the three criteria generally recognized as defining a computer: it can operate on a stored program, and one of its instructions is a conditional branch—that is, an instruction



Engineer's assistant. Photo at left shows HP-65 being used to figure sidewall capacitance; right photo demonstrates method in which the magnetic program card is inserted.

Spending too much time debugging wide band hi-slew op-amp circuits?

Try RCA's CA3100! Virtually free from Ringing.

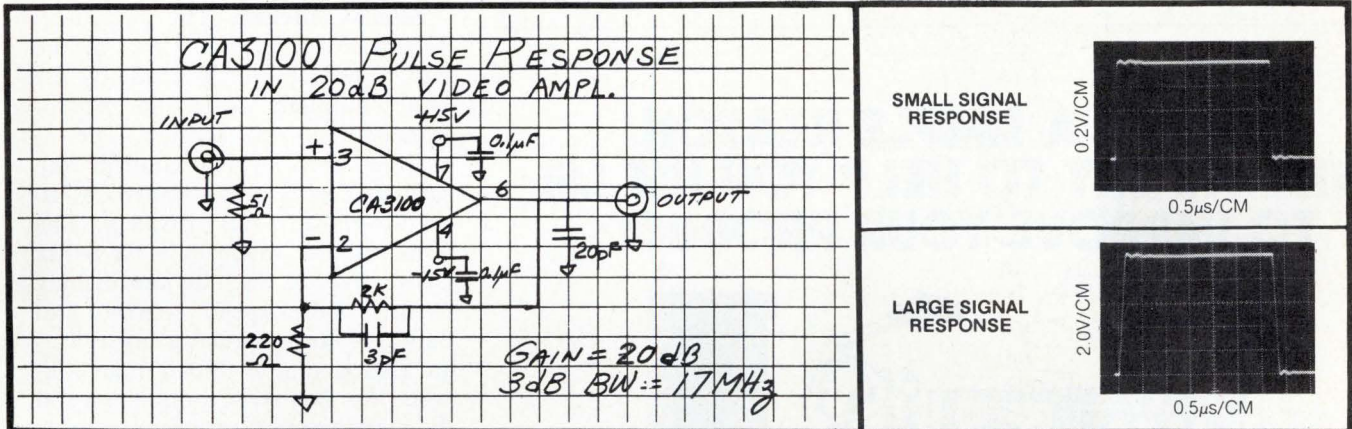

That's because we've combined all of the following features in a single device:

- High open-loop gain at video frequencies—42 dB at 1 MHz.
- High slew rate—70 V/usec (unity-gain, voltage follower, input compensated).
- High slew rate—25 V/usec (unity-gain, voltage follower, single capacitor compensated).
- Fast settling time—0.6 usec.
- High output current— ± 15 mA (min.).

These features are achieved with simpler circuitry because we've combined P-MOS and bipolar transistors on a single chip.

Compare the CA3100 with other wideband op-amps. You'll see the difference. Large signal or small... output waveforms are true reproductions of the input—virtually free from ringing and distortion. Also, compare open loop gain at Video Frequencies—22 dB at 10 MHz.

The CA3100 features dc offset adjust terminals for applications requiring offset null. It can be compensated with a single external capacitor and is pin compatible with other op-amps such as the LM118, LM307, and UA748.

Whatever your applications... high-speed comparators, instrumentation, video... take advantage of the CA3100's characteristics. You get all these features and more... with no tradeoff in price—\$3.50 for 1000 unit quantities.

The CA3100 is available in the standard TO-5 hermetic package, CA3100T, or the dual-in-line version, CA3100S. You can get them in production quantities from your local distributor or direct from RCA.

Interested? Let us send you the complete DATA SHEET! Write: RCA Solid State, Section 70A-24 Box 3200, Somerville, N.J. 08876. Or phone: (201) 722-3200.

RCA Solid State
products that make products pay off

International: RCA, Sunbury-on-Thames, U.K., or Fuji Building, 7-4 Kasumigaseki, 3-Chome, Chiyoda-Ku, Tokyo, Japan. In Canada: RCA Limited, Ste. Anne de Bellevue 810, Canada.

Probing the news

to itself can depend upon the results of a previous instruction. The one computer feature it lacks is the ability to operate on instructions in the same way as on data—for example, alter its own program as it goes along.

All the hard-wired functions of the HP-45 slide rule, and more, are

to be found in the HP-65. For instance, it has a floating "label" type of programing found only on expensive desktop models like the 9820 and 9830, a unique keyboard-matrix technique of entering program steps, and a microminiature magnetic recorder. There are 51 keyboard functions on the HP-65 (the HP-45 has 47) plus several other functions that are automatic. Actually, there is almost an infinite

number, since new functions can be programmed and operated with the user-defined keys.

Except for a new type of switch, the internal design of the new calculator contains no surprises. There are two transistors in the power supply and a few discrete passive devices, and the rest of the circuitry is in 12 custom LSI circuits—seven p-channel MOS, 1 n-channel MOS, and four bipolar devices.

Similar circuits. The p-channel circuits are similar to those of the HP-45. Indeed, they're made by the same suppliers—American Microsystems Inc. and Mostek. The n-channel chip, which controls the card reader, is manufactured at H-P's Loveland, Colo., division. The bipolar chips, made by H-P's Santa Clara division, include the display circuits, motor-speed control, and battery-voltage regulator, as well as an analog/digital circuit that contains the two sense amplifiers and the read/write controls for the magnetic recorder head. The p-channel-chip set includes a new program-storage array. That, together with a clock driver and the functional logic of the calculator, is assembled on a 40-pin hybrid IC at the Advanced Products division.

Among the mechanical innovations is that switch: a five-fingered affair etched from beryllium-copper that goes under the mainframe, beneath the recording head. This part

Open. The HP-65 uses 12 custom LSI circuits for the bulk of its circuitry.

THERE'S A SIMPLE REASON WHY WE TRY TO HELP YOU USE LSI TO IMPROVE YOUR PRODUCT:

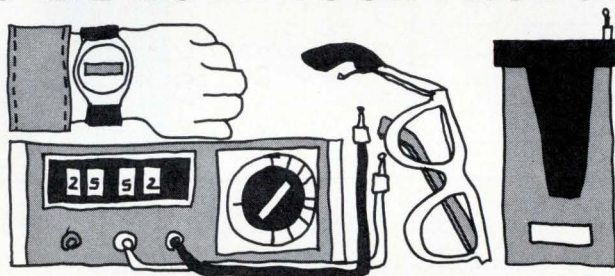

YOU SELL OURS.

When we say we want to help you apply advanced semiconductor technologies to improve your product, we mean it. Because we're motivated.

The reason for our incentive is simple: If your product works better or costs less or becomes more competitive in the marketplace, it will succeed. And when you succeed, we succeed. Because you sell our product.

We've built our business by helping manufacturers use state-of-the-art LSI technologies and processes to extend their own design and manufacturing capabilities. And our people have the know-how and track record to do it for you if it can be done.

We've been involved in developing and producing some of the world's most sophisticated integrated circuits. Like High-Density CMOS, a technique using a silicon-gate system of multi-layer interconnect to optimize the utilization of silicon real estate. And precision Bipolar ICs incorporating high-value thin-film resistors.

We'd like you to think about your product in our terms. If what we know could be of benefit, you should know about it—now. Call, write, or circle reader service number 245 today. We both may have a lot to gain.

WE CAN HELP, TOO.



MICRO POWER SYSTEMS

3100 Alfred Street, Santa Clara, CA 95050, Phone: (408) 247-5350, TWX: 910-338-0154
Japan: Yas Kanazashi, 21 Mori Bldg., 2-2-5 Roppongi, Minato-ku, Tokyo, Phone: 586-0471

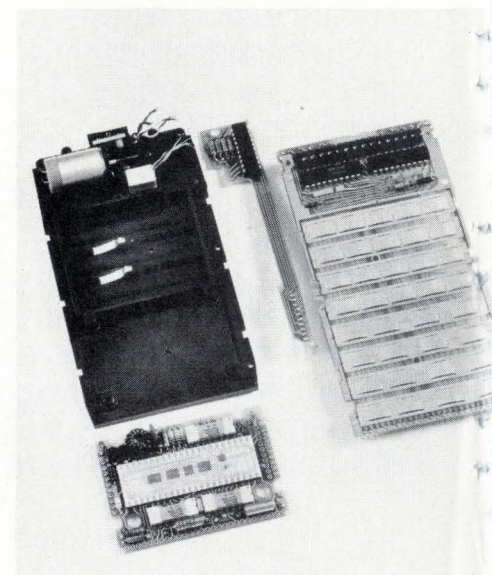

RCA's new plastic package is 100 times better...

We call it the E-55 Plastic Packaging System. But you don't have to remember the name — because every plastic LINEAR IC you buy from RCA is packaged in this new system that features IMPROVED RELIABILITY OF TWO ORDERS OF MAGNITUDE... at no extra cost.

Just look at the results of five real-time indicator tests. They tell the story.

- Temperature Cycling (at 200 cycles) — 1600 times improvement.
- Thermal Shock — 610 times improvement.
- Pressure Cooker — 250 times improvement.
- Bond Pull Strength — 10 times improvement.
- Hot intermittent opens — 250 times improvement.

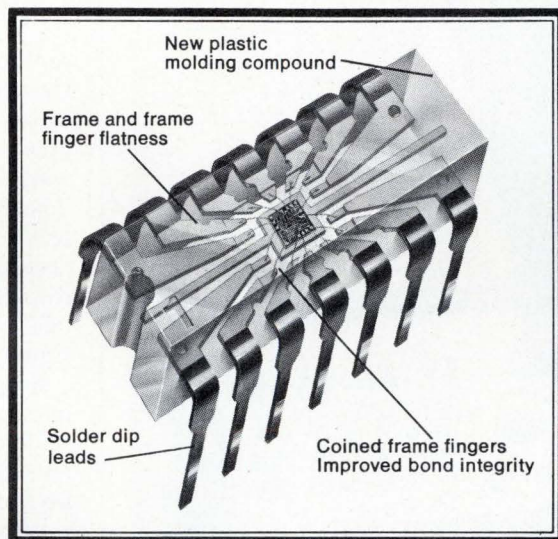

E-55 is a totally new system of plastic packaging. RCA has improved materials, handling procedures and process controls to bring you a low-cost state-of-the-art IC plastic package that matches the reliability of hermetic

packages under severe environmental stress. And it offers operation in the full temperature range of -55° to $+125^{\circ}\text{C}$. So design in a real package of reliability... RCA's 100 times improved E-55 Plastic Packaging system.

Want more details on the E-55 plastic package system and reliability test data?

Write RCA Solid State, Section 70A-24, Box 3200, Somerville, New Jersey 08876. Or phone: (201) 722-3200.

RCA Solid State
products that make products pay off

super 8 channel recorder

O.E.M. CONFIGURATION — No frills, no fancy case, a complete eight channel recorder at a low O.E.M. price. COMPACT — LIGHT — PORTABLE — 23" wide, 17" high and 6" deep. Weighs just 59 lbs. FULL 50 MM CHANNEL WIDTH — Permits greater resolution and ease of reading. AUTOMATIC CHART THREADING — Five second chart loading. CONTINUOUSLY VARIABLE CHART SPEEDS — ASTRO-DRIVE provides infinite chart speeds with Tachometer read-out. ASTRO-TIP STYLUS — Rugged, long-lasting tubular construction.

AND LOTS MORE!
PHONE OR WRITE FOR BROCHURE.

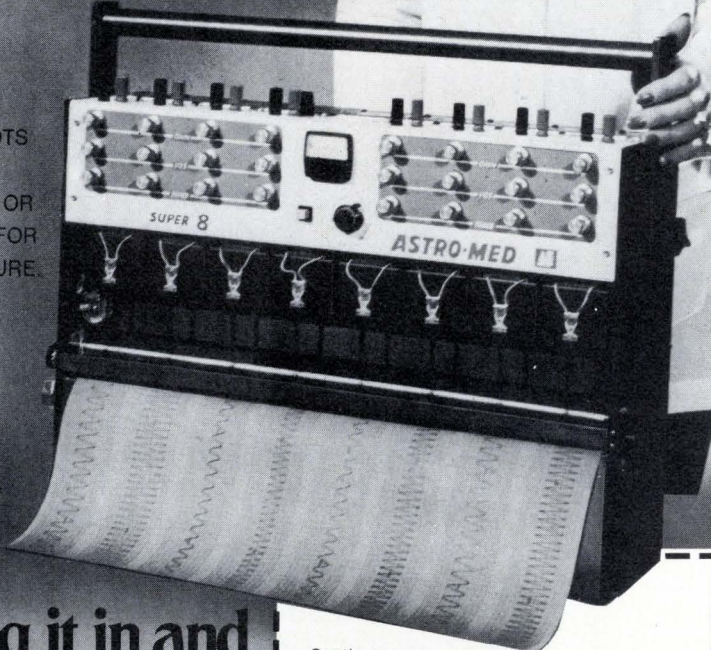

Plug it in and put it to work for only \$3388



A DIVISION OF ATLAN-TOL INDUSTRIES, INC.
ATLAN-TOL INDUSTRIAL PARK
WEST WARWICK, RHODE ISLAND 02893
(401) 828-7010

Gentlemen:
Please send complete literature.

Our application is _____

Telephone _____

Name _____

Title _____

Organization _____

Street _____

City _____

State _____ Zip _____

Probing the news

Showing the way

Suppose you want switch A at the top of the machine to be defined as πR^2 . First press the label key and the A key. Then you program for R to be entered in the X and Y registers and multiplied to get R^2 . Then π is entered and programmed to be multiplied by R^2 . Finally, a "return" (RTN key) is stored to return control of the logic to the keyboard.

replaces the half-dozen micro-switches of the HP-65's transistorized ancestor, the 9100 programmable calculator. The fingers sense when a card is inserted for reading, detect the file-protect corner (to protect a magnetic program card from accidentally recording unwanted information, a notched corner is cut off), and contact points on the printed-circuit pattern.

Program storage in the HP-65 is in shift registers, which act as a stack. Once a program is entered and stored, a blank magnetic card is inserted in one of two slots on the side of the machine and the memory contents are recorded on the card's two tracks.

Slide rule. After a trial run and editing, the card may be rerecorded. To copy a program, the card is read into memory, a fresh card is inserted, and the program is recorded again. And if the user wants to use the HP-65 as an electronic pocket slide rule, he merely operates the calculator without a program card.

While the machine's program storage capacity is 100 steps, the program can be far longer. If a program involves a hard-wired function, that part of the program requires storage of just one or two steps. Also, the eighth of the machine's 10 registers may be used as an index register. This has the effect of allowing routines to be looped up to 10 times.

Finally, program segments may be chained—that is, recorded on two magnetic cards. For example, in the EE program pack supplied by H-P, the filter-design program is on two cards.

Modern Production Calls For Modern Manufacturing Equipment

If you need technological equipment for electrical and electronic components production, you will naturally want the best and most advanced. In this sector VEB Elektromat Dresden is the partner you're looking for.

Our equipment program includes

Complete systems and automatic machines for applications in semiconductor fabrication and stator-winding technology

Varnished-wire production equipment
Fabrication equipment for dry-reed contacts
Automatic cable forming and laying machines
Automatic grinding machines for film resistors

Equipment from VEB Elektromat Dresden is efficient of high technical perfection always up-to-date

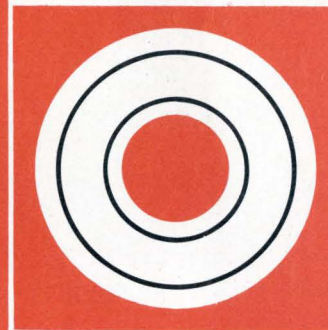
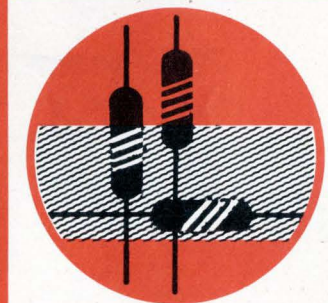
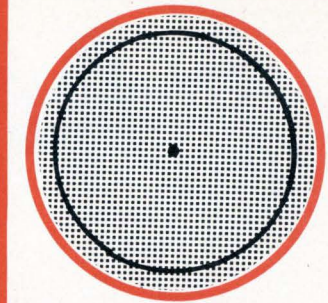

VEB ELEKTROMAT DRESDEN

Betrieb für Projektierung, Automatisierung
und Rationalisierung der elektronischen Industrie
DDR-808 Dresden, Karl-Marx-Straße



DNEVEST EXPORT

Volkseigener Außenhandelsbetrieb der
Deutschen Demokratischen Republik
DDR-108 Berlin, Johannes-Dieckmann-Straße 7/9

Another first.

10-bit monolithic CMOS DAC.

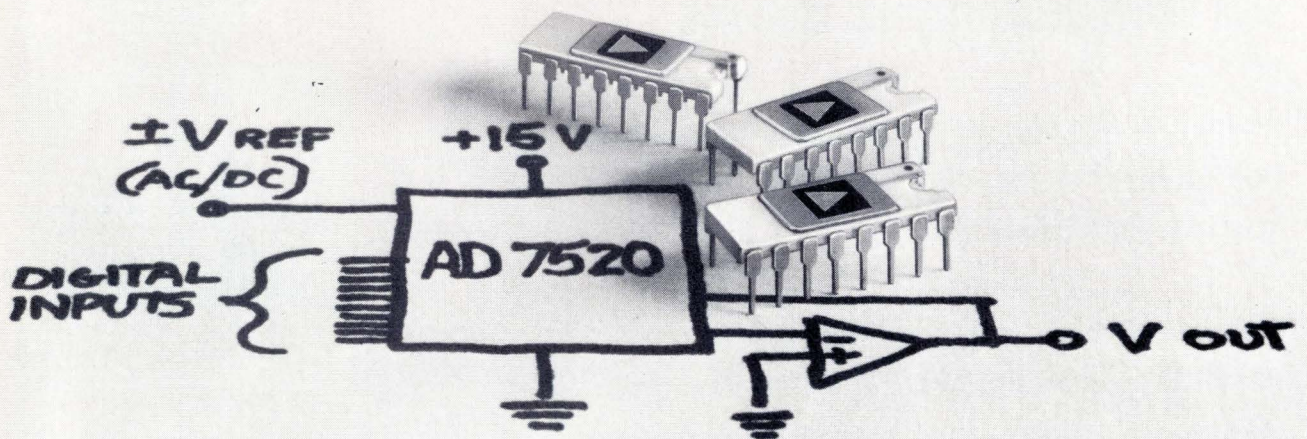

True 10-bit accuracy.

0.05% max. nonlinearity over $\pm V_{REF}$ range.

2 ppm/ $^{\circ}$ C max. nonlinearity temperature coefficient.

10 ppm/ $^{\circ}$ C max. gain temperature coefficient.

Low power consumption.

20mW power dissipation.

Versatile — like two DACs in one.

A straight (unipolar) converter. 2 quadrant multiplier.

4 quadrant multiplier. AC/DC reference. CMOS and TTL/DTL compatible.

The 16-pin ceramic DIP AD7520 comes in 3 versions.

100 piece prices are:

\$17 for 10-bit resolution and 8-bit accuracy.

\$25 for 10-bit resolution and 9-bit accuracy.

\$33 for 10-bit resolution and 10-bit accuracy.

To order, give us a call.

East Coast: 617-329-4700

Mid West: 312-297-8712

West Coast: 213-595-1783

CMOS DAC is just another innovative use of advanced technology to keep you — and us — a step ahead of everyone else.

From Analog Devices, Inc., Norwood, Mass. 02062

 **ANALOG
DEVICES**

Data processing, LSI will help to bring sight to the blind

Data from semiconductor camera in an artificial eye will be processed by circuitry held in spectacle frame, then transmitted to an array of electrodes implanted in a blind person's brain to evoke images

by staff of The Neuroprostheses Program, *Institute for Biomedical Engineering, University of Utah, Salt Lake City, Utah*

□ The world's population may include as many as 15 million blind people. In the United States alone, where blindness-related economic costs have been estimated to exceed \$1 billion annually, about 300,000 are classed as legally blind, and about 100,000 have no useful sight.

What's more, fewer than 10% of the blind are mobile with a cane or other aid, and fewer than 20% read braille. One goal of the neuroprostheses program of the University of Utah, therefore, is to develop an electronic system that would enable a blind person to "see" well enough to move about safely and with confidence and to read ordinary printed or written material at useful speeds.

Experiments on blind volunteers^{1,2} show that they can be made to perceive true visual sensations when trains of brief current pulses are applied to electrodes in contact with the visual areas of the brain. This technique works even when the pathways between the eye and brain have partly or completely degenerated.

One train of pulses delivered to an electrode results in the perception of a spot of light, called a phosphene. The higher the instantaneous current, the brighter this phosphene appears. A few dozen phosphenes created by stimulation of electrodes appropriately selected from an implanted array should present the kind of simple pattern that might indicate an obstacle in a person's path. Also computer-simulation studies suggest that as few as 256 brightness-modulated phosphenes can produce a recognizable half-

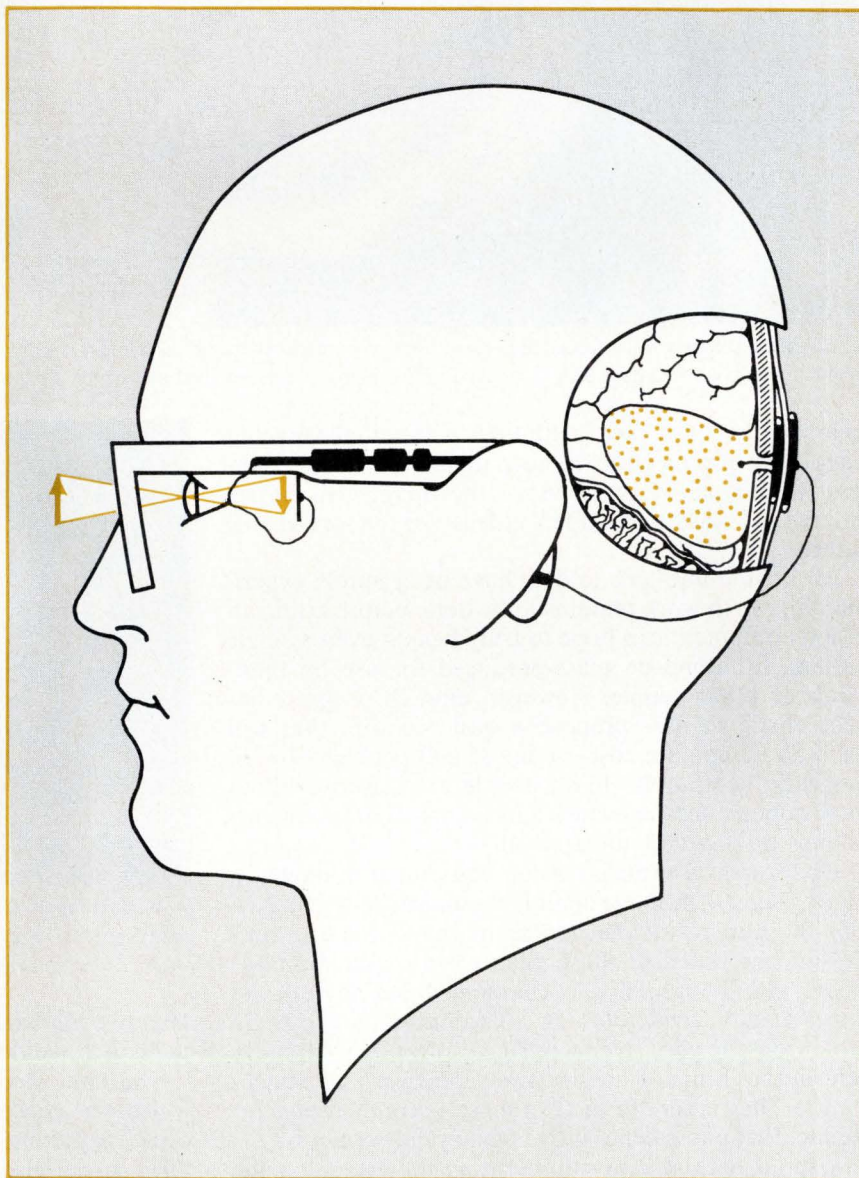

1. Electronic eyesight. Proposed prosthesis is expected to give blind people enough vision to become mobile and even read. Here, a tiny image array in the eyesocket is scanned by a microprocessor—mounted on glasses—that then computes a pattern and sends the data to registers, current sources, and electrodes under the skull to re-create the image.

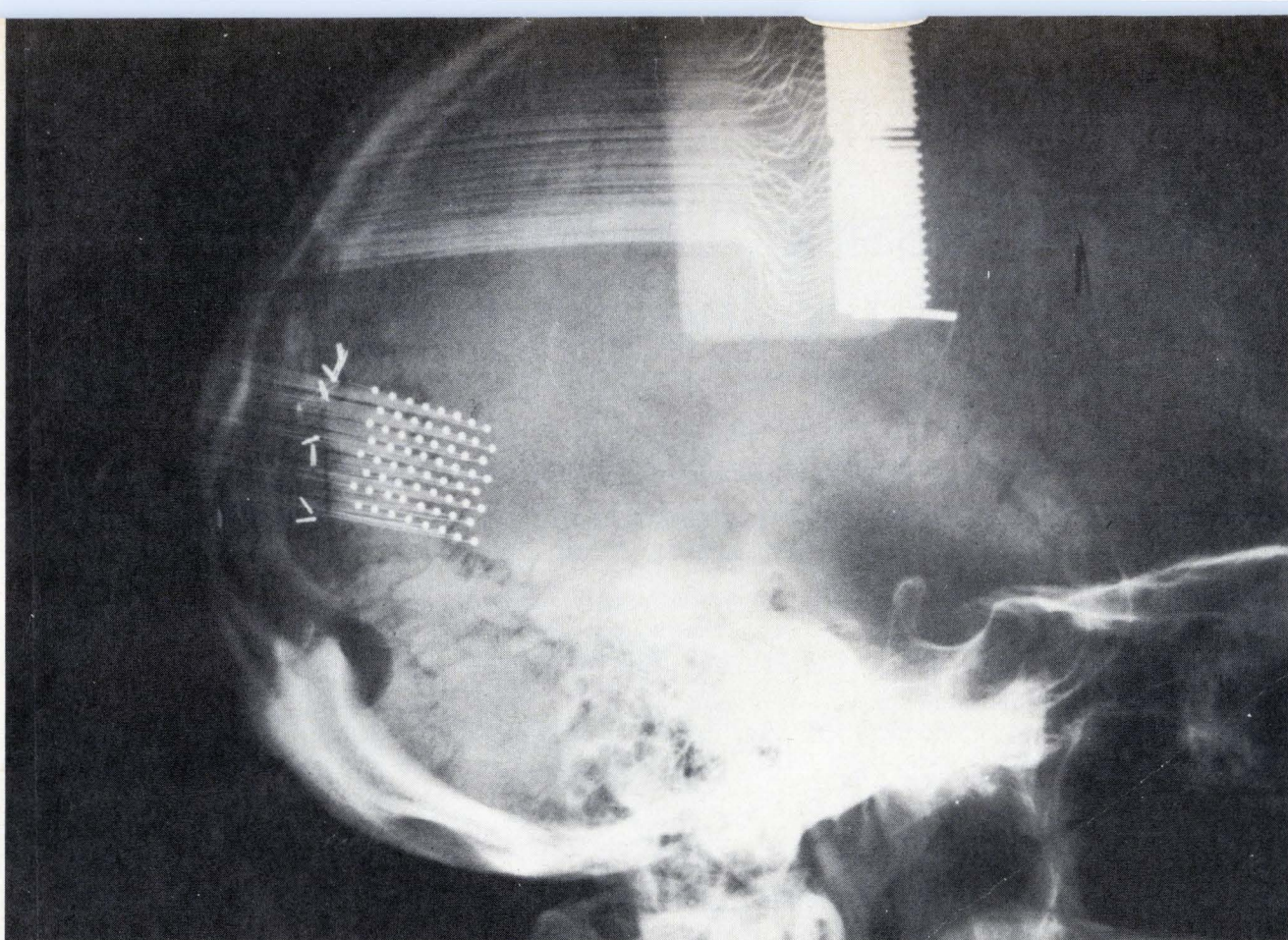

2. Electrode matrix. Minute platinum electrodes in contact with a visual cortical area of the brain create tiny spots of light called phosphenes. The blind volunteer patient X-rayed here is helping to determine how images are created by stimulation of electrodes.

tone picture of a face. Although colored phosphenes have been produced in blind patients, most are colorless. Consequently, we believe the image will be restricted to "black and white," at least for the foreseeable future.

All human implants to date have been purely experimental. Much work remains to be done before artificial-vision equipment can hope to truly benefit even a single patient, let alone be mass-produced for use by thousands of blind people. However, enough progress has been made to now propose a basic concept that will have an acceptable cost—about \$5,000 per unit—be esthetically acceptable—blind people are sensitive about their appearance—and meet physiological requirements as they are presently understood.^{1,2,4}

The proposed artificial-vision equipment is shown in Fig. 1. Here, a glass eye containing an image-sensing array—the camera—is attached to the remaining eye muscles and mounted in the patient's eye socket. Suitable arrays, either MOS chips or charge-coupled devices, are commercially available. A (disconnectable) camera cable from the glass eye feeds signal-processing circuitry held in the frame of the "dummy" glasses. This attachment of the camera to the eye muscles compensates for the fact that phosphenes move with eye movements.

A serial data stream, representing the image on the array, is passed from the signal processor to a receiver and other circuits implanted between the skull and the scalp. This transmission takes place through inductive coupling between coils on each side of the scalp, so that

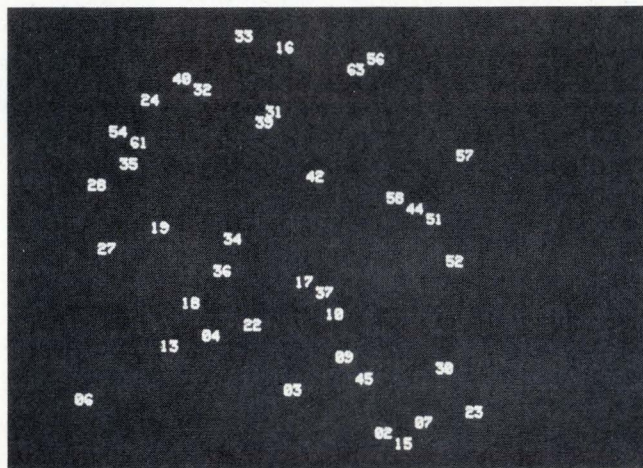

3. Visual mapping. Regular array of electrodes produces scatter of phosphenes in volunteer's field of "vision," as shown here by jumble resulting when electrode numbers map phosphene locations.

the infection hazard incurred by bringing wires through the skin is avoided.

The data stream modulates a 1-megahertz carrier, which was chosen because higher frequencies begin to cause diathermic heating of intervening tissue. The rectified carrier also supplies dc power to the internal electronics package. The implanted electronics package is, in turn, connected with the electrodes in contact with visual areas of the brain's surface. Locating this implanted electronics package between the scalp and the

skull facilitates power dissipation, and provides room for blocking capacitors in series with each electrode. We are also exploring the feasibility of an analogous auditory prosthesis for the deaf.³

What the brain requires

The surgical procedures for implanting electrodes involve opening the skull, but are relatively straightforward and can be readily performed while the patient is under local anesthesia. The primary cortical areas for vision are found on both hemispheres of the brain. With an average patient, the total exposed area on both hemispheres can accommodate about 256 surface electrodes, each 1 square millimeter in area.

The X-ray photograph in Fig. 2 shows a matrix of 64 electrodes in contact with the surface of one cortical hemisphere of a blind, volunteer patient. A common return electrode is also necessary, and more recent work suggests its optimal configuration is as a ground plane surrounding all the active electrodes.

To create a phosphene, the visual cortex is stimulated by passing a train of constant-current, symmetrical, biphasic pulses of up to 8 milliamperes (zero-to-peak) through the electrode. The electrode-brain interface has an effective resistance of about 3,000 ohms, so that the internal electronics package must be capable of generating up to 24 volts in each direction.

This stimulation must not damage the brain, even after long periods. Experiments to date on animals are encouraging, but much work remains to be done in this area. Deleterious effects observed so far have been traced to toxic electrolysis byproducts formed at the electrode/fluid interface and possibly—if there is a net dc component to the stimulus—to electrophoresis of tissue components as well. These effects are minimized by use of symmetrical biphasic pulses, with capacitive coupling insuring against any net charge transfer.

From an engineering-design viewpoint, the implanted electronic packages must not only perform all their required logic and analog functions within very narrow spatial confines—they must also be able to withstand the biological environment. Experiments by us on about 400 live animals indicate that many of the presently used semiconductor and packaging materials are biologically acceptable. However, very special packaging techniques will be required to maintain a hermetically sealed package for implantation in the corrosive body environment.

Processing the image

Information processing—converting the scanned signals from the image sensor into currents that will produce phosphenes which are recognized as the corresponding image by the brain—is one of the major areas of investigation by the our team [*Electronics*, Dec. 20, 1973, p. 29]. Although many factors go into the image processing, it appears that all necessary processing of data can be accomplished by a microprocessor, with suitable memories, that can be mounted in the frame of the glasses. This means that the artificial-vision prosthesis can be optimized by modifications to the external electronics—or associated software—after implantation.

Among the image-processing tasks involved are:

Authors and their specialties

W.H. Dobelle, biophysicist and director of the neuroprostheses program, has a background of basic research in visual physiology.

J.N. Fordemwalt, a physical chemist interested in IC process development, was associate director of R&D at American Microsystems Inc.

J.W. Hanson, a device physicist specializing in ion-implantation technology, came to the University of Utah from Sprague Inc.'s R&D laboratory.

D.R. Hill, an IC circuit design engineer, worked on microprocessor development at Motorola Inc.

R.J. Huber, a physicist with experience in both integrated-circuit process and design, was director of General Instrument Corp.'s microelectronic R&D laboratory.

M.G. Mladejovsky is responsible for computer graphics technology, including design, construction, and operation of the system used in the operating room.

K.R. Smith, an IC circuit design engineer, previously served as a technical director at General Instrument Corp.'s microelectronic R&D laboratory.

- Enhancing both the edges of images and the contrast.
- Producing a correlation between the image and the spatial relationships of the phosphenes.
- Linearizing the relationship between the brightness of the image on the sensor and the perceived brightness of the phosphenes.

The algorithms for processing data to enhance edges and contrast will probably be the same for all patients, although certain of the parameters in these algorithms may require manual or automatic adjustment to suit a particular patient.

Before it is possible to obtain correlation between an image and the phosphenes, the apparent position of each phosphene relative to all other phosphenes must be determined—a process called phosphene mapping. For instance, if a row of 10 electrodes is stimulated, the blind person will not perceive a straight line, but rather a scattered field of 10 phosphenes (see Fig. 3). The objective of mapping in this case is to find those electrodes that will produce a perceived straight line.

Unfortunately, the phosphene map differs both from patient to patient and with the location of the electrode matrix on the cortex of a particular patient. Fortunately, it should be feasible to determine the visual map once and then store this data in a read-only memory.

The inclusion of image-processing capability means that more image-sensing areas can be used in the camera than there are implanted electrodes. For example, the camera could have between 4,000 and 10,000 discrete sensing areas to service 256 electrodes. As a result, inputs from several related image spots can be processed to provide one electrode with the signal that will produce the phosphene brightness best for that particular image. Furthermore, the variable camera-scanning rates can function as the equivalent of an iris by compensating for varying light levels on the image.

A given level of current at different electrodes will not normally produce the same perceived brightness of the corresponding phosphenes. The relationship is nonli-

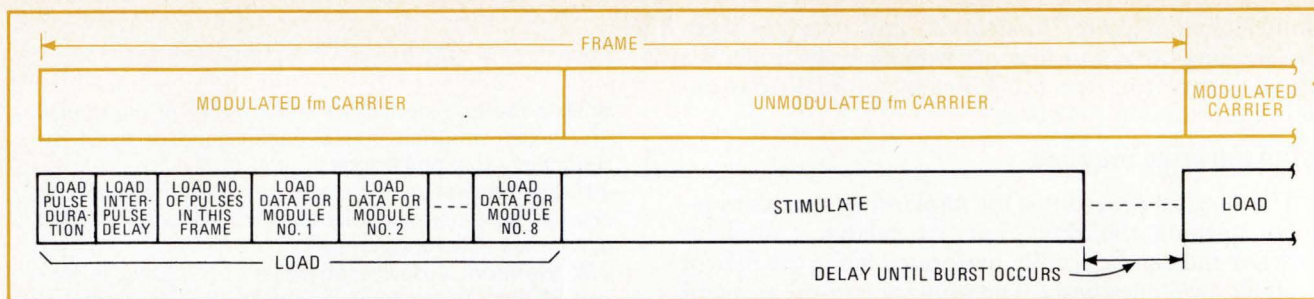

4. Load and stimulate. After the camera scanning and image processing takes place, the information is transmitted through the skull to load eight embedded registers. Then the stored stimulation data sequentially converts the frame data into a perceived image.

near, and threshold values differ from electrode to electrode. The goal is to produce at least eight levels of perceived brightness (or shades of gray), and experiments show that 32 levels of current should provide enough leeway to produce these eight brightness levels in any given phosphene. Thus, one of the requirements of image processing is to translate the desired brightness level into the proper amount of current for a given electrode. This situation, too, differs from patient to patient.

How the system functions

To review, the external components consist of a glass eye, containing a photosensitive array, and dummy glasses, containing image-processing circuits and a transmitter to send power and data through the skin by inductive coupling. Implanted are: a receiver, which provides power for the other circuits and produces a data train by demodulating the incoming frequency-modulated carrier; buffer memories, into which the data trains are loaded; and electrodes, which stimulate the brain under control of the data in the buffers.

Image information will be transmitted in bursts of bits, one burst for each image or frame. Each frame may be completely different from the previous frame, and the transmitted data contains all of the information for every electrode to be stimulated. The amplitude and the order of stimulation of the individual electrodes can be varied, while the pulse duration and the delay between successive pulses will be common to all stimulated electrodes. Each half of the biphasic pulse could last from about 50 to 500 microseconds. Below 250 microseconds, the amount of current needed to evoke a phosphene rises sharply.

The electronics will permit a pulse repetition rate of 12 to 500 pulses per second, although 32 pulses a second seems adequate to avoid image flickering. The frame rate will be varied from 0.3 to 32 frames a second, with up to eight electrodes being pulsed simultaneously.

Phosphenes cannot be continuously presented because neural accommodation will cause the phosphene to fade, due to a decrease in nerve cell excitability. Therefore, an interframe delay of between 50 and 1,000 milliseconds is added at the end of each frame to permit nerve cells stimulated in the preceding frame to "rest."

The pulse duration, the interpulse delay, and the number of pulses in this frame are all manually adjustable parameters. They will be based on the patient's own preferences, being set after the implant, and will undoubtedly require later "tweaking" to optimize.

The two major steps in creating a frame are loading

and stimulation (Fig. 4). Not shown is a three-bit synchronizing word initially transmitted to the implanted receiver. As shown, though, the first piece of information transmitted during a frame is five bits to denote duration of each phase of the biphasic pulses; specifically, the biphasic pulse will last, in 32-microsecond increments, from 32 to 1,024 microseconds. After that comes the interpulse delay, another five-bit word, which sets the pulse-repetition rate. Next follows a 10-bit word, which controls the number of pulses in a frame.

The balance of the load cycle is composed of eight groups of data, each divided into 32 10-bit words. Each one of the eight groups of data controls a separate stimulator module, which is connected to 32 separate electrodes. The first five bits of the 10-bit data word select the electrodes to be stimulated. The next five bits set the current source to the correct value for this electrode stimulation. The current amplitude can be controlled from 0 to 7.75 mA in 32 increments.

The fact that both the address and the amplitude of the stimulation are transmitted to eight parallel stimulator modules gives great flexibility because the processor can control which electrode to stimulate, the order of stimulation, and multiple stimulation of the same electrode in the same frame period. This scheme implies that a maximum of eight electrodes can receive simultaneous—rather than interlaced—pulses. Simultaneous stimulation of electrodes cuts down frame time, although it requires greater instantaneous current from the power supply.

Deriving the data words

How these eight groups of 32 data words are obtained is shown in the system diagram (Fig. 5). The camera is scanned in an arbitrary but recurring sequence, depending on the techniques used for information processing by the data processor and associated memories. The camera's output is converted to a voltage proportional to the integrated light intensity, and the voltage is digitized by the analog-to-digital converter and fed to the data processor for image processing and conversion.

Image processing includes correction for the nonlinearities in the photosensitive array and enhancement of edges and contrasts. Next comes conversion of the digitized light levels from the sensor into as many signals as there are electrodes in the brain, in this case 256. In addition, the processing must now assign one of eight perceptual-brightness levels to each electrode. Three-bit words containing this information are stored, in a sequence dictated by the phosphene-mapping ROM, in a

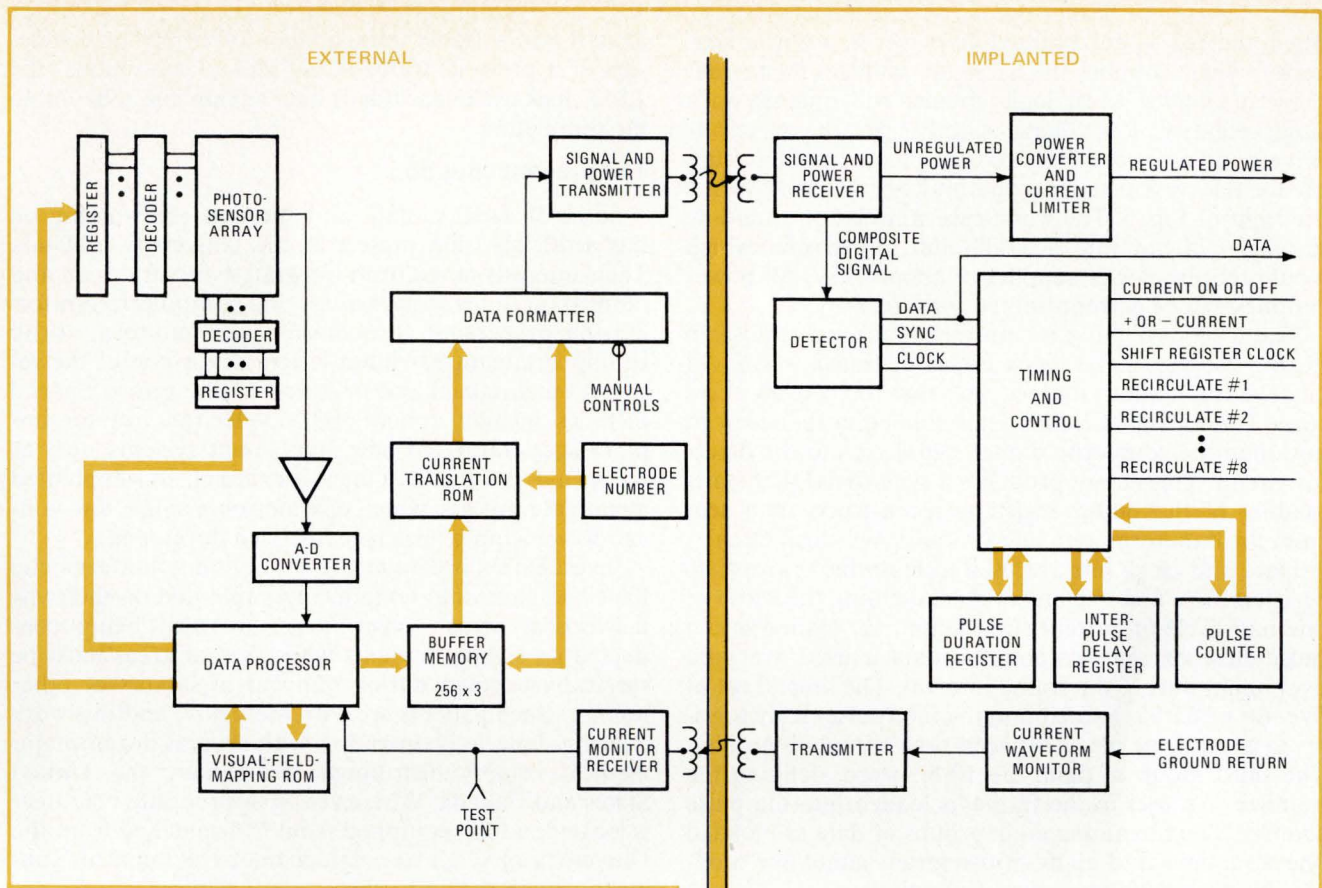

5. External, internal. The electronics package outside the skull scans the image array and implements image processing. Then the data stream is transmitted through the skull and loaded in registers, and finally the electrodes are stimulated by current pulses.

256-by-three-bit random-access buffer memory. Once filled, the buffer contains all the data necessary for one frame and does not accept new data, even though the camera may be receiving new images.

The remaining problem is to translate this frame data into a serial stream so it can be transmitted through the scalp to the implanted electronics shown in Fig. 5. This is done by the (external), data formatter and associated electronics.

The data formatter generates the composite data for the load cycle for each frame. After the three sync bits and the 20 bits describing the pulse parameters, it has to provide the eight sequential groups of 32 10-bit words described above. To create one 10-bit word, an eight-bit electrode number supplied by the data processor interrogates the buffer memory for the three-bit word describing the brightness level at that electrode. The three-bit word and the eight-bit number are combined to form an 11-bit address for a 2,048-by-five-bit current-translation ROM. This ROM's output is a five-bit word that corresponds to the actual current at that particular electrode for the desired perceptual level. The first three bits of the eight-bit electrode number specify the group, and the remaining five bits are combined with the five-bit current value to form one of the 10-bit words for transmission. An interframe delay is generated by controlling the delay time between successive bursts.

The serial signal transmitted through the scalp is rec-

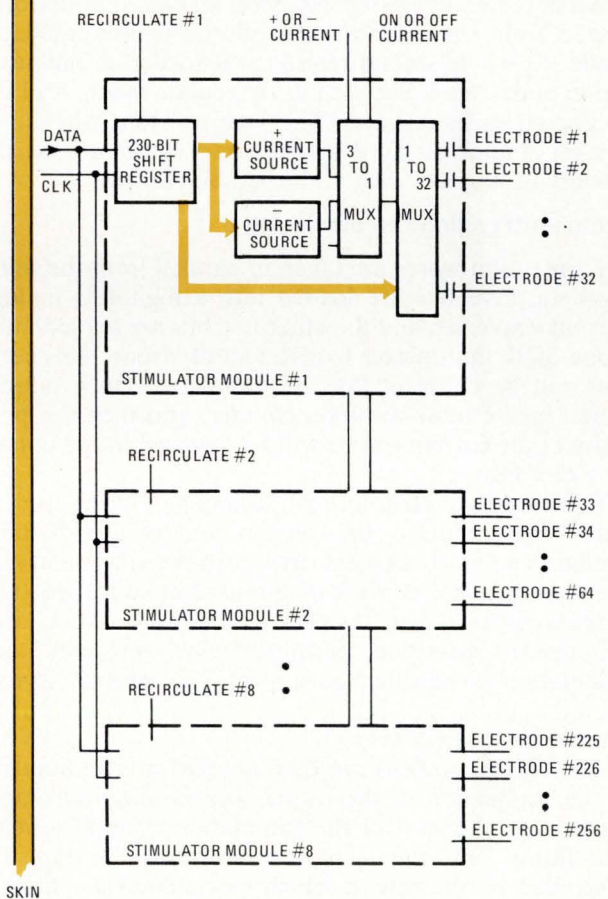

tified and fed as unregulated dc power to a power converter, which supplies the necessary voltages for the implanted circuits. Most logic circuits will operate on a single-polarity, low-voltage supply, but the electrode drivers must have a high-voltage plus-and-minus supply for the current sources and multiplexers as shown at the right of Fig. 5. The worst-case stimulation would be driving 7.75 mA into a 3,000-ohm impedance, which would require power supplies of about ± 25 v. All power supplies will be current-limited for safety.

The load-data burst is transmitted through the scalp during the first 2,583 clock cycles of transmission. All current-stimulation sources are shut off during load time. The fm signal is first demodulated in the receiver, and then the composite digital signal goes to the detector circuit. This circuit produces a sync signal that starts loading of the buffer registers, reconstructs data sent from the data formatter, and produces the clock signal.

Data and clock bits are used to load the appropriate registers. The first five bits of data, defining the width of one half-cycle of current stimulation, are loaded into a pulse-duration register, and this data is used over and over again during the frame interval. The second set of five bits of data is loaded into the interpulse-delay register to control the delay between each stimulation pulse. The third group of data, the 10-bit word, defining the number of pulses in the frame, is loaded into the pulse counter. The remaining eight groups of data are loaded one at a time into eight shift-register stimulator modules. Register loading occurs sequentially.

After the first register has been loaded, it is disconnected from the data bus and placed in a recirculate mode. Next, the second register is loaded with the next group of data and placed in its recirculate mode. And so on for all eight registers. The loading stops when the first set of address and amplitude information resides in the last 10 stages of each of the 320-bit registers.

From shift register to electrode

Eight 10-bit words are taken in parallel from the shift registers. Five bits are loaded into a digital-to-analog current converter, and the other five bits are loaded into a one-of-32 multiplexer to select an electrode. This current will be delivered for the number of clock pulses stored in the pulse-duration counter, and then the polarity of the current source will be reversed for an equal period of time.

Following completion of the second half of the stimulation current pulse, the current sources are disconnected. The shift registers are advanced 10 counts so that each holds a new set of stimulation addresses and amplitudes in its last 10 stages. The current sources are reconnected after the interpulse-delay time, and the stimulation is repeated as above. This process is repeated until the number of pulses specified in the pulse counter has been delivered.

The current sources are disconnected in all modules at the completion of the frame, and no electrodes are active until the start of the stimulation cycle of a new data frame. Thus the delay time between pulse trains is controlled by the rate at which new frames are transmitted. The new data frame starts when sync is received and new data is loaded into the registers. It is possible

to start a new frame immediately following the conclusion of a previous frame so an almost continuous (the 2,853 clock cycles excluded) data stream could be fed to the stimulators.

The present situation

Some 35 faculty, staff, and students are working on this artificial-vision project at the University of Utah. Their interests range from integrated-circuit design and fabrication to neurophysiology and computerized information-processing procedures. A modern, fully equipped integrated-circuit laboratory is one of the resources maintained and operated by the group. Special facilities include a new 300,000-electron-volt ion-implant accelerator. To help implement systems such as the visual prosthesis, a new n-channel, ion-implanted metal-gate process, which operates on a single low-voltage power supply,⁵ has recently been developed.

Investigation is continuing with blind volunteers who have had electrodes temporarily implanted on their visual-cortical areas. Experiments are also being conducted on sighted patients whose visual areas must be surgically exposed during removal of tumors or other lesions.⁴ Such patients are extremely rare, and this work is being done in cooperation with several dozen major medical centers distributed throughout the United States and Canada. Whenever an appropriate volunteer is located, a fully equipped team is dispatched from the University of Utah to conduct the experiment in conjunction with the host neurosurgical service.

In these human experiments, a Digital Equipment Corp. GT-40 graphics system (PDP-11 computer and CRT display) simulates the image-sensor array, and a PDP-8 computer drives the electrodes implanted in the patient. The patient indicates the perceived location of a phosphene using a simple terminal, and the resulting visual map is displayed on the CRT terminal (Fig. 3) where individual electrodes can be selected for stimulation by use of a light pen.

The ultimate goals of the neuroprostheses program include development of sensory prostheses for the blind and deaf that can eventually be distributed for about \$5,000 apiece, and which will probably require about \$2,000 worth of additional surgical care and post-operative training. While the cost may seem high, and thus limited to well-to-do families, recent underwriting of much more expensive artificial-kidney care by the Federal Government has provided a precedent for similar support in the future for sensory prostheses. The large numbers of people who can enjoy the benefits of such prostheses for the blind and deaf should eventually make an attractive "mass" market for IC manufacturers to produce the necessary image arrays, micro-processors, and memories, although this stage is still well in the future. □

REFERENCES

1. G. Brindley and W. Lewin, "The Sensations Produced by Electrical Stimulation of the Visual Cortex," *J. Physiol.*, vol. 195, pp. 479-493, 1968.
2. W. Dobbelle, M. Mladejovsky, and J. Girvin, "Artificial Vision for the Blind," *Science* (in press), 1974.
3. W. Dobbelle, M. Mladejovsky, S. Stensaas, and J. Smith, "A Prosthesis for the Deaf based on Cortical Stimulation," *Ann. Otol. Rhinol. Laryngol.*, vol. 82, pp. 445-463, 1973.
4. W. Dobbelle and M. Mladejovsky, "Phosphenes Produced by Electrical Stimulation of the Human Occipital Cortex, and their Application to the Development of a Prosthesis for the Blind," *J. Physiol* (in press), 1974.
5. R. Huber, J. Forde, J. Hanson, D. Hill, M. Mladejovsky, K. Smith, and W. Dobbelle, "A New n-Channel Metal-Gate MOS Technology," *Electronics* (in press), 1974.

Forced air cooling in high-density systems

The trend toward miniaturization may seem to call for natural convection; but reliability analysis shows forced air cooling can boost system survival by 75%

by Gordon M. Taylor, *Rotron Inc., Woodstock, N.Y.*

□ Heat sinks alone cannot dissipate excessive heat in a system when the air around them does not move rapidly. The problem is becoming more pervasive as system designers crowd ever larger numbers of circuit boards into ever smaller regions, reducing the number and width of possible air passages. However, air forced through the narrow passages by a fan will remove the heat and thereby raise the life expectancy of a high-density electronic system.

Two other factors that contribute to a system's tendency to overheat and so detract from its long-term reliability are: the increasing density of the circuitry on the chips inside the IC packages, and the increasing speeds at which this circuitry operates. These trends, too, are helping to spread the use of forced air cooling, which is also highly effective in smoothing temperature fluctuations at critical semiconductor junctions in densely packed, high-speed logic systems.

In the past, however, the pressure to optimize reliability has made packaging engineers hesitant to add an electromechanical fan to an electronic system that contains no moving parts. But the reliability of air-moving devices has recently risen an order of magnitude, improvements having been made in the insulating materials in stator windings and in the application of precision bearing design. The mean time between failures of a fan moving air at 100 cubic feet a minute at 158°F can by now reach over 50,000 hours.

The limitations of natural convection

Buoyancy is the driving force moving air in a natural convective air stream. But buoyancy can't deliver velocity much over 0.5 foot per second. The reason is that the specific weight of warmed air doesn't differ appreciably from that of the cooler air surrounding it. And when this small buoyant force must also overcome the counteracting viscous phenomena that develop along stationary air masses, the air flow rate is limited to a fraction of a foot per second. This is serious because the thermal path between a stationary wall and an air stream moving at velocities below 0.5 ft per second is relatively poor.

Figure 1 illustrates how the velocities and the thermal profiles of air moving past a stationary wall affect heat transfer. The velocity plot indicates that the speed of air at the boundary is zero because at the boundary air particles adhere to the wall. As the distance from the wall

along the y axis increases, the velocity of the air also increases until it reaches the mainstream velocity. As for the temperature profile, notice that the air temperature at the wall is virtually the same as the wall temperature, and diminishes along the y axis to the value of the mainstream air temperature.

The shape of the velocity profile is crucial because the coefficient of heat transfer at the wall is a function of the rate of change of the temperature along an axis perpendicular to the wall. Increasing the flow rate enlarges this differential and thus the effective heat transfer from

Life saver. Typical modern fan can add 75% to the expectation of system survival. Device delivers 70 ft³/min when driving a static load that's the equivalent to 0.1 inch of water.

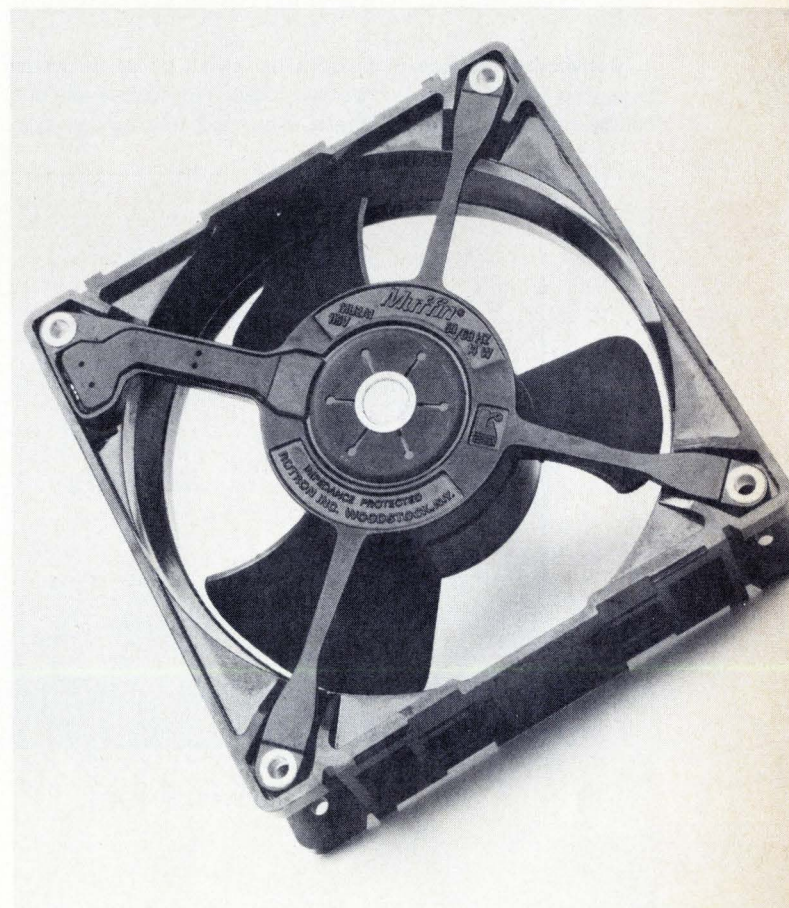

the wall to the air stream. Since the natural-convection flow rate is limited, the value of this differential is also limited. However, forced air can develop velocities far in excess of those attainable with natural convection, enhancing the transfer of heat across the boundary.

Faster air flow yields a second benefit because speed increases the temperature differential between the moving air stream and the stationary wall being cooled. This is important because heat transfer is also a function of temperature differential. The larger temperature differential results because a molecule of air at higher speeds has little time to absorb heat, so it will not reach as high a temperature as a slower-moving air particle.

Thus faster air flow increases both the coefficient of conduction and temperature differential.

The goal behind improving heat transfer in a system is of course greater reliability. Proof that adding an air-moving device to a system that formerly relied on natural convection does extend a system's life is given by the following case history.

Bathtub curves

The curve labeled (a) in Fig. 2 is the survival expectation of a minicomputer packaged in a 36-by-12-by-12 in. envelope which employed natural convection cooling. The "early and chance failures" portion of the curve—the infant mortality region—describes the time interval immediately following manufacture, when marginal and defective components are weeded out. The second portion of the curve—"random and chance failures"—describes the useful life of the system. The final portion of the curve, "wearout and chance failures," signifies the wearout period of the equipment's life span

where the failure rate climbs rapidly.

Originally the manufacturer had relied upon the natural convection of air to cool the ICs and other components and maintain temperatures below safe values. But the high packaging density of the equipment prevented the air flow from cooling all heat sources adequately, and average life expectation, as indicated in Fig. 2, was about 20,000 hours. This life span was too short, so the manufacturer turned to forced air cooling.

The forced-convection heat-transfer equation is:

$$Q = C_p W \Delta T$$

where Q = amount of heat dissipated, C_p = specific heat of air, W = air mass flow rate, and ΔT = temperature rise through the system. Incorporating conversion factors and specific heat for air at sea level yields an equation for the flow rate required to dissipate a given amount of power:

$$CFM = (3160 \times kW) / \Delta T^\circ F$$

where CFM = flow rate measured in cubic feet per minute at an air density of 0.075 lb/ft³; kW = power dissipated within the system enclosure, in kilowatts; and ΔT = average temperature rise of air passing through the system, in degrees fahrenheit.

For the minicomputer, the maximum allowable temperature within the cabinet and the maximum ambient were determined to be 113°F and 68°F, respectively. Secondly, the total power dissipated within the cabinet was computed as 1 kilowatt. These numbers, when substituted in the above equation, work out at $(3160 \times 1 \text{ kW}) / (113 - 68)^\circ F$, or 70.2 ft³/min.

The system was then subjected to an aerodynamic

1. Convective interface. Plots depict the velocity profile and the temperature profile of the boundary between a cooling air flow and a stationary surface. Optimized convective cooling requires the rate of change of temperature at the boundary and the temperature differential between the wall and the mainstream to be maximized along an axis perpendicular to the wall.

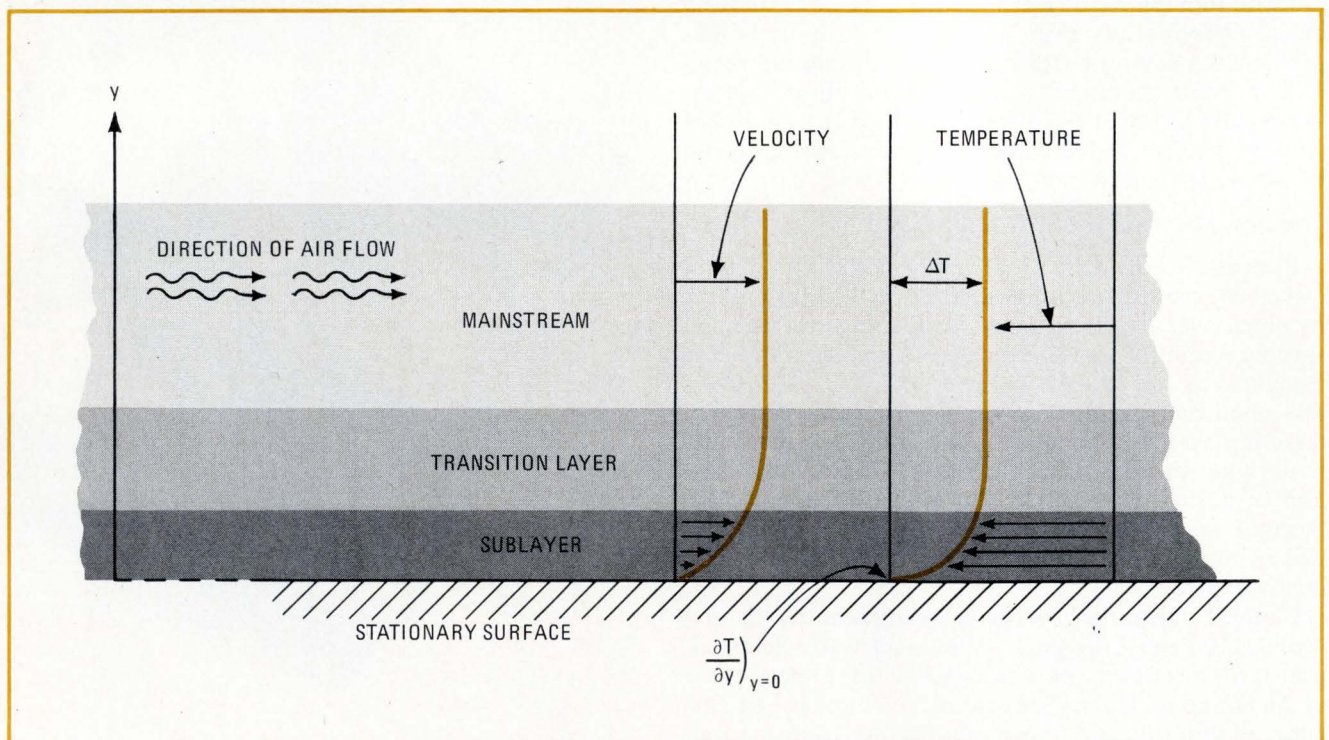

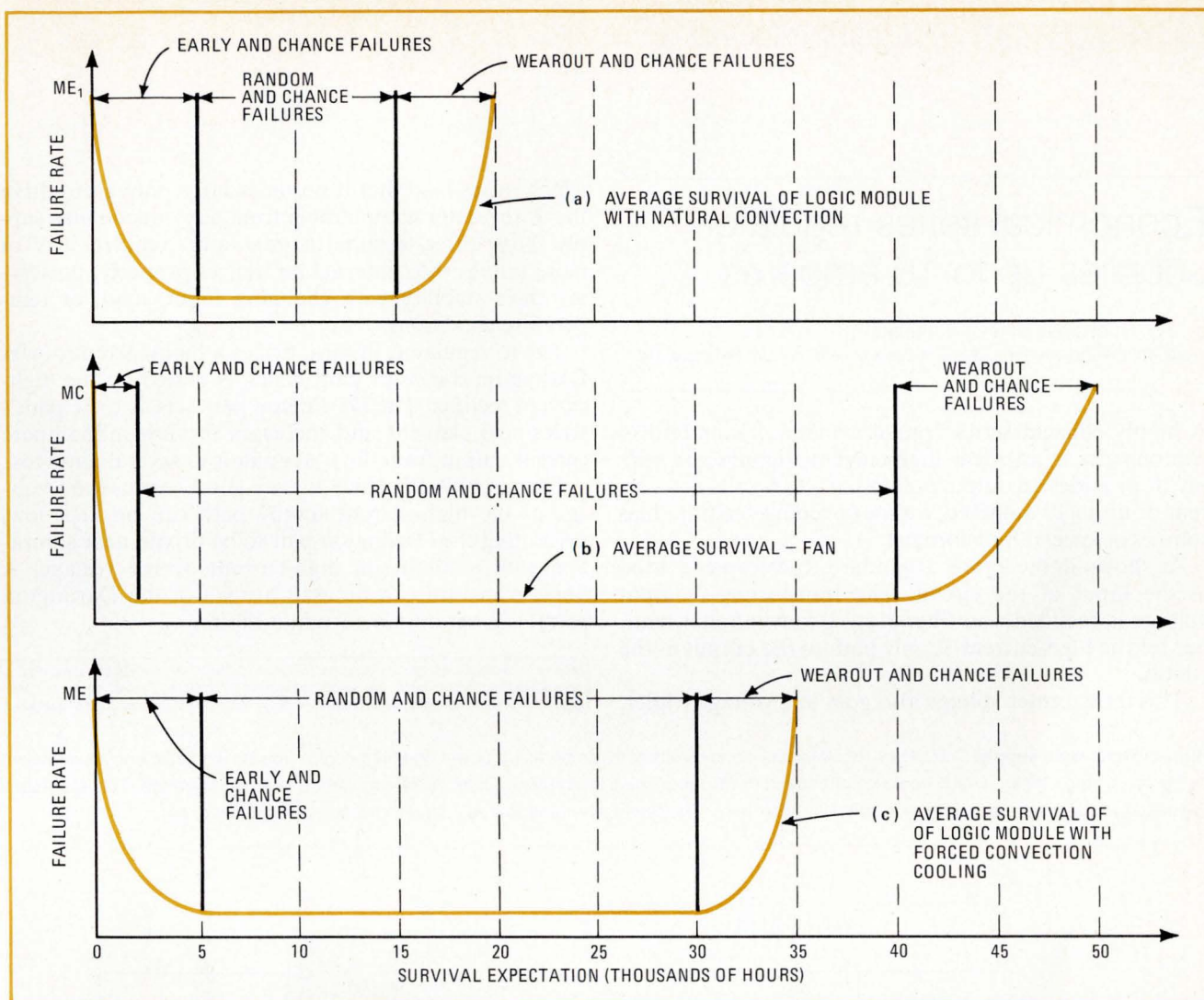

2. Stretchout. Survival expectation of a minicomputer (20,000 hours) was extended to some 35,000 hours by adding a fan. Such life extension runs counter to the common belief that a forced-air-moving device degrades reliability.

study to determine its resistance to air flow. This turned out to be 0.1 in. water-gauge static pressure at 70 ft³/min.

On the basis of this data the fan shown on page 87 was selected. It measures 4-11/16 in. square by 1½ in. deep. Packaging engineers were able to accommodate it in the original equipment enclosure by rerouting some wire harnesses and moving several fasteners. The cost was less than one cent per watt dissipated. The fan occupied less than 0.5% of the enclosure volume.

Life tests of the fan indicate an average survival of 50,000 hours at 158°F, plotted as curve (b) in Fig. 2. The "early and chance failures" as plotted are really quite conservative. The reason is that electrical failures, which used to account for many of the early failures in air-moving devices, have been drastically reduced as a result of improved magnet-wire insulation and rigorous inspection procedures. Bearing failure is the principal wearout failure mode.

Increased survival

Addition of the fan raised the minicomputer's survival expectation from 20,000 to 35,000 hours—an im-

provement of 75%. This survival expectation is plotted as curve (c) in Fig. 2.

This curve is based on the formula:

$$ME = MC - [ME_1 + (MC - ME_1)]K \text{ hours}$$

where ME_1 is the average survival for the over-all system with natural convection cooling, MC is the average survival rate for air-moving device, and K is an empirically derived derating factor. Therefore, when $ME_1 = 20,000$ hr, $MC = 50,000$ hr, and $K = 0.3$, ME works out at 35,000 hr.

The result is conservative because the derating factor, K , generally used by system and air-moving equipment manufacturers, is in the neighborhood of 0.12 rather than 0.3 as shown. Thus survival values determined by the formula given with a derating value of 0.3 can be interpreted to mean "at least as good as."

The formula can be applied generally to ascertain the increase in survival attainable by adding an air-moving device. Should empirical data for the over-all system be lacking, the designer can combine the survival rates for individual components by employing traditional reliability analysis techniques. □

Economical series regulator supplies up to 10 amperes

by J.E. Buchanan and C.W. Nelson
Westinghouse Electric Corp., Systems Development Division, Baltimore, Md.

A highly efficient series regulator made of standard IC components is an ideal high-current digital-logic supply. It provides an output voltage of 5 to 6 volts at a current of up to 10 amperes, without needing separate bias sources or special transformers.

As shown in the figure, a standard transformer is used at the input of the circuit. The transformer's output voltage is rectified and filtered in a conventional manner for the high-current-supply path to the output of the circuit.

This transformer voltage also goes to a voltage tripler,

which raises it so that it becomes large enough to drive the IC regulator without help from any outside bias supply. Most three-terminal IC regulators require 10 v or more to bias their internal references properly, preserving their stability with changing input, load, or temperature conditions.

The IC regulator, in turn, drives a high-current power Darlington transistor pair, which is biased by the high-current rectifier. The Darlington pair acts as the circuit's series-pass element and increases the low-milliampere current output from the IC regulator to several amperes.

The circuit's efficiency is very good because the voltage of the high-current supply path can be kept low, permitting the Darlington pair to be driven near saturation with a minimum high-current source voltage. A single transistor can be used instead of the Darlington pair if a lower output current is desired. □

Designer's casebook is a regular feature in Electronics. We invite readers to submit original and unpublished circuit ideas and solutions to design problems. Explain briefly but thoroughly the circuit's operating principle and purpose. We'll pay \$50 for each item published.

High-current logic supply. This series regulator develops 5 volts at 10 amperes for powering digital-logic circuits. High efficiency is achieved by using a voltage tripler, which operates directly from the input-line transformer, to bias the IC regulator's internal reference. This eliminates the need for a special bias supply or a special transformer. The Darlington transistor pair serves as the series-pass element.

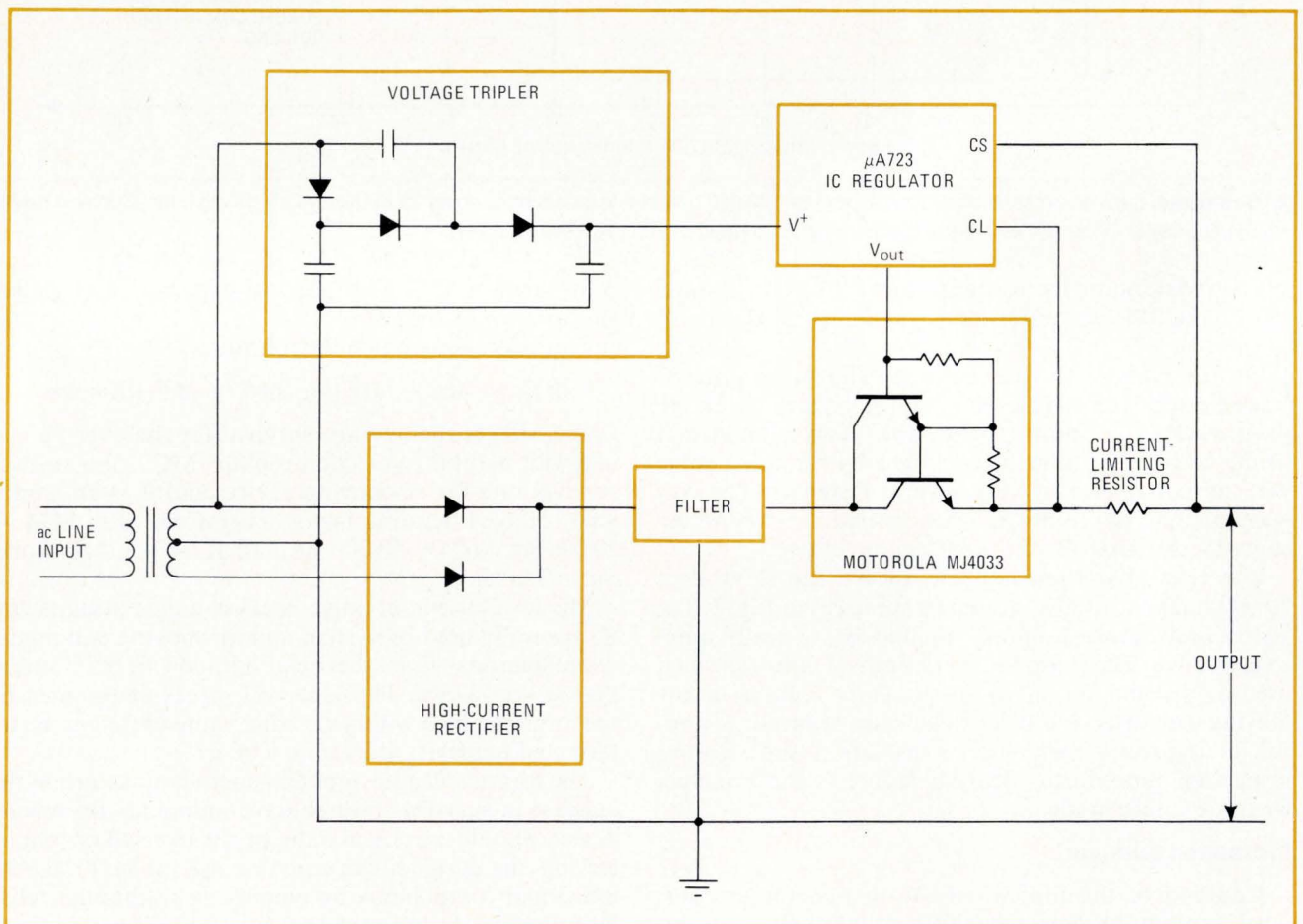

Multiphase clock produces nonoverlapping pulses

by Glen Coers
Texas Instruments, Components Group, Dallas, Texas

A multiphase clock pulse generator can be put together from a few IC packages by taking advantage of the versatility of an MSI TTL decoder/demultiplexer. The clock generator can be programmed to produce from two to seven differently phased clock-pulse trains, and none of the pulse edges will overlap. Furthermore, the time between the pulses of the various clock phases is the same as the width of a single pulse. This means that each individual clock phase is well-defined, and there is no

pulse-edge ambiguity, as with other clock-generating techniques.

An MSI decade counter is used with the MSI decoder/demultiplexer, which is connected as a three-line-to-eight-line decoder. Only three of the outputs of the decade counter are needed.

The number of clock phases is determined by the decoder output that is selected to reset the counter to zero. The counter's reset line is simply connected to the decoder's output line that is next in the sequence. As shown in the figure, a five-phase clock is produced by wiring the counter-reset line to the sixth decoder's output line.

The inverter at the input of the counter assures that the decoder is disabled when the count is changing and enabled after the data has stabilized. This eliminates the transients that can appear on the decoder's output lines when the counter is changing states. □

Programmable clock. Two MSI devices—a decade counter and a three-line-to-eight-line decoder—can be wired as a simple multiphase clock generator. The circuit can produce from two to seven clock phases without any overlapping pulse edges. The number of clock phases is determined by connecting the counter's reset line to the decoder output line that is next in sequence. A five-phase clock is shown here.

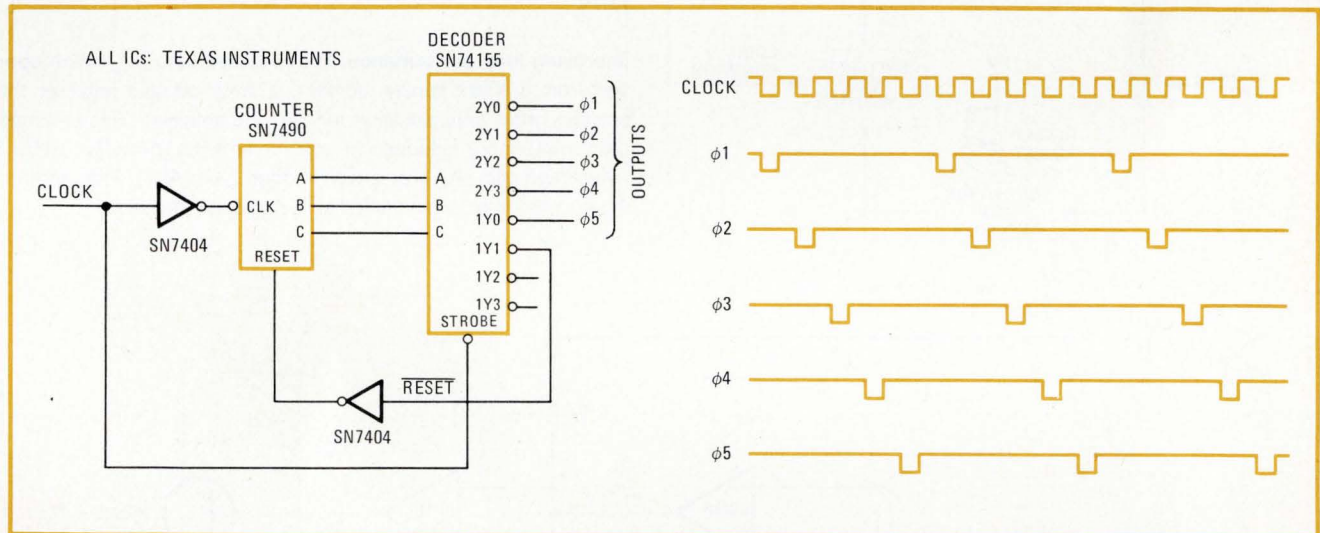

Phase-locked loop adjusts to varying signal conditions

by Charles A. Watson
E-Systems Inc., Greenville, Texas

In many phase-locked receivers, the gain of the amplifier in the phase-locked loop must be changed to adapt the loop gain to varying signal conditions. If the amplifier's gain and offset voltage are changed simultaneously, the signal-acquisition time can be shortened, and signal-to-noise ratios can be optimized.

When the entire loop, including the phase detector,

operates from a single supply, the output of the phase detector must be other than zero to have the VCO rest at its midrange frequency. If not of the proper magnitude, this nonzero output offsets or even saturates the loop amplifier, driving the VCO to some non-midrange frequency.

Therefore, an offset voltage, which permits the loop to be adjusted for a midrange VCO rest frequency, is usually introduced at the loop amplifier. If the loop amplifier's gain must be changed to accommodate varying input-signal conditions, this offset voltage must also be changed to maintain the same VCO midrange frequency.

The figure contains a block diagram of a phase-locked loop (a) that includes a switched-gain amplifier, which provides offset compensation for the loop amplifier in response to remotely commanded gain adjust-

ments. The schematic (b) for this variable-gain amplifier, which only requires a quad comparator and a single transistor, is also given in the figure.

When the input logic command to the circuit is high, comparators COMP₁ and COMP₂ clamp resistors R₁ and R₂ to ground. The circuit's voltage gain can be written as:

$$A_{v(1)} = \left(\frac{R_1}{R_1 + R_3} \right) \left(\frac{R_4}{R_2 + R_4} \right)$$

Since R₁ = R₂ = R₃ = R₄, then:

$$R_4/R_2 = R_3/R_1$$

and:

$$A_{v(1)} = 1$$

When the input-logic command to the circuit is low, comparators COMP₁ and COMP₂ unlatch so that resistor R₁ is no longer grounded and comparator

COMP₃ performs as a voltage-follower, clamping the voltage across resistor R₂ to the desired midrange offset value. The circuit's voltage gain can now be written as:

$$A_{v(0)} = (R_2 + R_4)/R_2 = 2$$

Therefore, if the relationship of R₄/R₂ = R₃/R₁ is maintained, the circuit's gain can be switched between A_{v(1)} = 1 and A_{v(0)} = (R₂ + R₄)/R₂. Potentiometer R₅ is used to adjust the offset voltage for the circuit's high-gain mode.

Offset and drift problems are minimal with this circuit because the comparators have unusually low output-saturation characteristics (10 millivolts at 0.1 milliampere). Also, when the circuit is in its low-gain mode, the outputs of comparators COMP₁ and COMP₂ appear as common-mode (temperature-tracking) signals to output comparator COMP₄. Moreover, when the circuit is in its high-gain mode, the leakage current through COMP₁ is only around 0.1 nanoampere, which is too small to create an offset problem.

The full-power bandwidth of the circuit is 10 kilohertz for an output-voltage swing of 10 volts peak-to-peak. □

Improving loop performance. Phase-locked loop (a), which operates from a single supply, contains a switched-gain amplifier that provides offset compensation for the loop amplifier. This switched-gain amplifier (b) responds to logic commands, providing either a low-voltage gain (A_{v(1)}) or a high voltage gain (A_{v(0)}). The output of the loop oscillator is maintained at its midrange frequency.

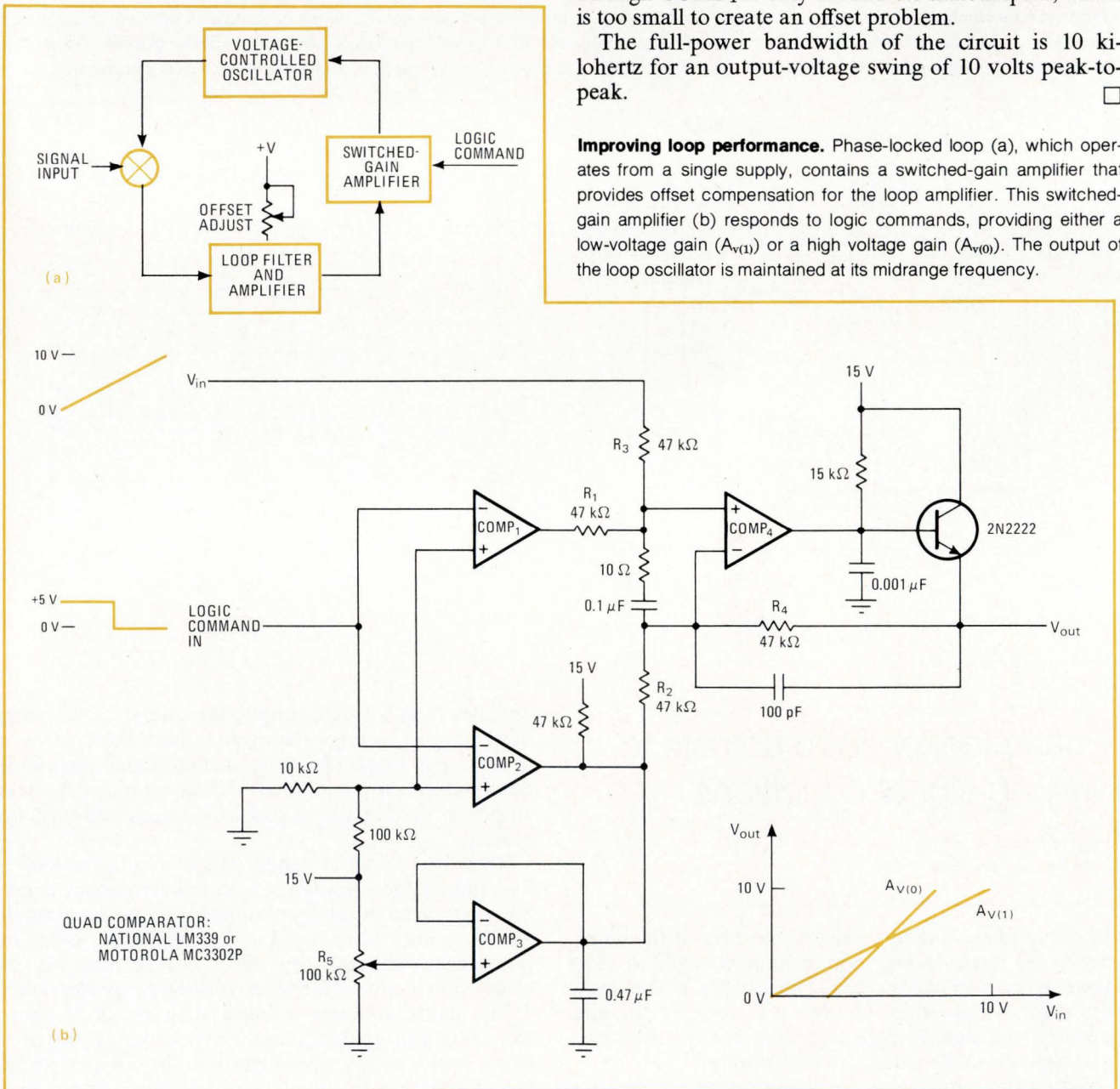

CMOS Analog Switches

TTL-controlled switches handle full $\pm 15V$ signal swing
with only $\pm 15V$ supplies.

New **DG200** and **DG201** devices provide channel and gain selection for analog signals up to $\pm 15V$ power supply levels without exceeding switch signal handling levels (see typical applications circuit below). Devices feature:

- Monolithic CMOS construction; drivers and gates on a single chip.
- Low r_{DS} over full temperature and signal range.
 $< 100 \Omega$ for **DG200** (dual SPST)
 $< 250 \Omega$ for **DG201** (quad SPST)
- Static protection on all terminals.
- Break-before-make switching action.
- Independent pairs of sources and drains for maximum flexibility.
- Direct TTL, DTL and CMOS compatibility.

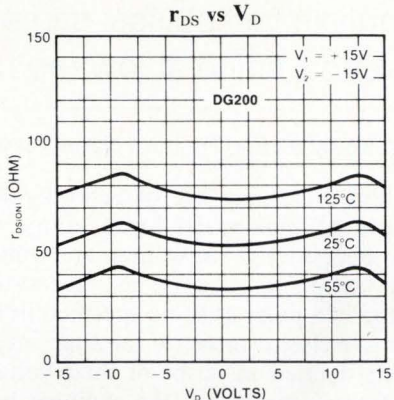

With supply voltage levels less than $\pm 15V$, the maximum analog signal always equals supply voltage.

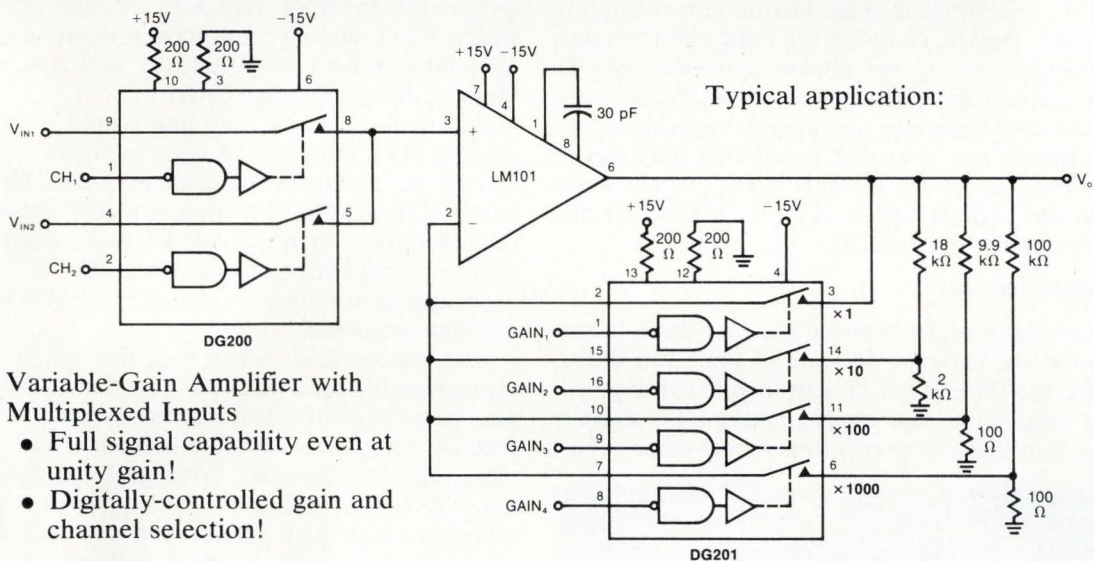

Variable-Gain Amplifier with Multiplexed Inputs

- Full signal capability even at unity gain!
- Digitally-controlled gain and channel selection!

The **DG200** and **DG201** are ideal devices for digital computer interface with this analog world. If your switching problems are unique — and whose aren't — our applications people are eager to help. For complete information

write for data

Applications Engineering: (408) 246-8000 Ext. 802



Siliconix incorporated

2201 Laurelwood Road, Santa Clara, California 95054

Which method should be used to measure fast pulses?

There are three popular instruments that engineers use to capture and analyze fast pulses; sampling scopes are best for extreme speeds, single-shots shine at low rep rates, and real-time scopes cost least

by Martin Marshall and Richard Nyder, *E-H Research Laboratories Inc., Oakland, Calif.*

□ With the increasing use of Schottky TTL, ECL, and other types of high-speed logic, many engineers are finding it necessary to make time and voltage measurements on fast pulses. Usually, it is necessary to measure the voltage of a pulse at some specified time after a trigger event, or else to measure the time interval between two points defined in terms of their voltage levels. To make these measurements, the engineer has a choice of three basic tools: a fast real-time scope, a sampling scope, or a single-shot measurement module.

Since the capabilities of these instruments overlap to a considerable degree, choosing the right tool for a particular measurement is not always a trivial task. To make the decision intelligently, at least six factors must be considered: bandwidth, sensitivity, repetition rate, accuracy, throughput, and cost. Bandwidth here can be related to rise time by the formula $ft = 0.35$, where f is the bandwidth in hertz, t is the rise time in seconds, and 0.35 is a dimensionless constant.

First, check the cost

The interrelationships between the first three factors are shown in the two-part diagram of Fig. 1. In the region where the three types of instruments overlap, it is probably best, for a fast approximation, to compare them on a price basis. The real-time scopes come in first

with a price range of \$2,500 to \$7,000. The single-shot modules are second at about \$3,500 to \$12,000, and the sampling scopes last at about \$5,000 to \$20,000.

It will often be necessary to add other equipment to the basic measurement tool to get the actual data that is needed, and a realistic analysis must take into account the costs of the add-ons. Some typical examples of the various measurement systems that can be put together, along with their costs, are shown in Fig. 2.

Accuracy is usually second in importance to price. Single-shot modules routinely provide accuracies to within 1% of reading for voltage measurements and 3% of reading on time measurements, although, sometimes, they can do considerably better.

Both real-time and sampling scopes without digital readout are limited by the accuracy of the analog trace and by the ability of the user to eyeball the measurement. Although the deviation of measurement portions of the scopes is often rated at 3%, this usually translates into an over-all error of as much as 5% for skilled engineers and technicians, and from 5% to 10% for production-line personnel.

Last, but not least, when high throughput is needed, measurement speed must be considered. When used as part of an automated measuring system, a single-shot module completes its measurement cycle in slightly more than 1 millisecond. With reed switching, the total time per measurement is on the order of 3 to 4 ms. A sampling scope with digital readout, operating in the same sort of automated system, will require about 25 to 35 ms per measurement, including switching time.

As yet, no real-time scope is capable of operating in a completely automatic mode. That is, none is capable both of putting out digital data and accepting control inputs from a computer, calculator, or other controller.

Vive la différence

At the edges of the overlap regions of Fig. 1, the most striking differences between the three measurement tools occur in the area where the repetition rate of the signal is low. For example, for a measurement on a pulse with a rise time of 5 nanoseconds and a repetition rate of about 10 Hz, a real-time scope with a bandwidth of 70 MHz can handle the rise time well enough, but there's still a problem of poor visibility of the trace.

The best instrument for these low-repetition-rate measurements is the single-shot module, but single-

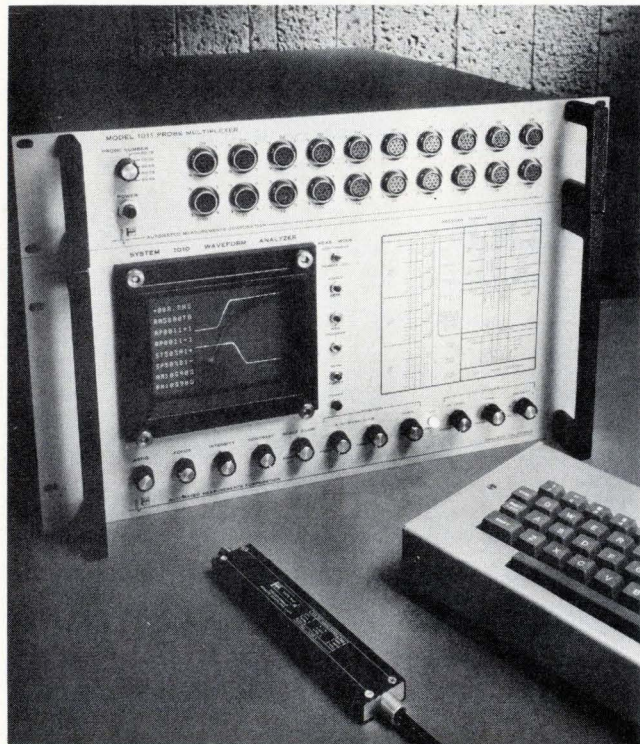

shots have the disadvantage of providing no picture of the signal they are measuring. For engineers who are accustomed to seeing traces on a CRT, this can be a little disconcerting, but for fast pulses at low repetition rates, there is simply no way to produce a good CRT trace. The single-shot module needs, at most, two events to make a measurement, and test personnel soon become reconciled to the absence of a picture.

Real-time scopes are limited by the amount of beam energy per unit of time that they can produce. As the beam is forced to move faster and faster, the trace becomes less and less visible unless the event-repetition rate is increased. At 10 events per second, it is difficult to see a trace written at a sweep speed of 20 to 30 ns/cm unless the viewer's eyes are adapted to the dark. Even then, a sweep speed of 10 ns/cm is about the limit of the human eye to read existing oscilloscopes.

An alternative to the real-time scope is the sampling oscilloscope. Because the sampling scope can store its input samples for display, there is no problem reading the CRT. Other problems, however, do arise. One trouble is that at speeds below about 10 events per second, their memories are likely to get a bit shaky, and their accuracies can suffer as a result. The resulting phenomenon is known as "dot slash" or "bleeding." It manifests itself as either a downward or upward drift of the sampling-scope dot.

A second problem that can arise when a sampling scope is used to measure a signal with a low repetition rate is the inordinately long time required to make the measurement. For a 1,000-dot scope measuring 10 events per second, for example, it takes 200 seconds to complete a single measurement. If an average-of-10 measurement is desired, the operator must wait around the lab for about 20 minutes. Some sampling scopes, it

should be noted, have a short-sweep mode that can save from 30% of the single-measurement time to as much as 70% of the average-of-10 measurement time, but even that's wasting a lot of valuable engineering time.

The frequency game

Although the single-shot module is the obvious choice when dealing with a low repetition rate, it is no universal panacea. If, for example, one wishes to measure a signal with a high repetition rate and a high frequency, any of the three instruments will do—up to a point. But at about 500 MHz, the real-time scope drops out because it simply cannot deflect an electron beam any faster. At about 1 GHz, the single-shots drop because of microwave-matching problems related to their physical design. This is the true realm of the sampling scope. For frequencies from about 500 MHz to 18 GHz—corresponding to rise times of 700 ps down to about 20 ps, respectively—the sampling scope stands alone.

In most applications, voltage sensitivity is not a problem. Engineers generally work with signals between 200 mV and 20 V; if higher voltages are encountered, it is a simple matter to use external attenuators. The problem area, as one might guess, is at the low end of the voltage range. For testing magnetic cores, plated-wire memories, high-speed MOS circuits, or op amps, to name but a few examples, noise can be the most important limitation on measurement accuracy.

A normal test procedure on an op amp, for example, consists of hitting it with a pulsed input signal of 10 mV or less in peak value. A sampling scope used to measure such a pulse will show from 1 to 2 mV of noise, or a 10% to 20% error. A real-time scope can reduce the noise to 500 μ V, or a 5% error, and a single-shot can get the noise as low as 200 μ V or a 2% error. For some appli-

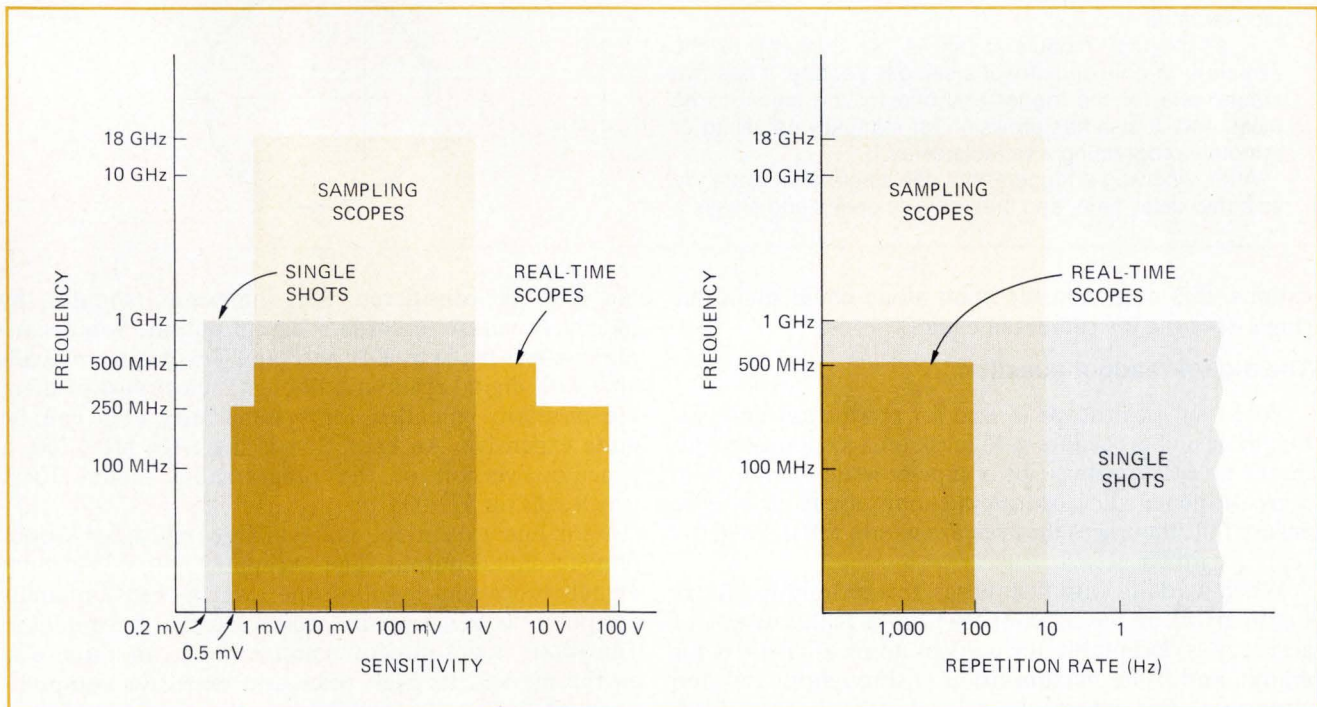

1. Trade-offs. For extremely fast rise times (which imply signal components at very high frequencies), the sampling scope has no competition. For very low repetition rates, including the once-and-only-once signal, the single-shot is the tool of choice. And when a broad range of voltage must be covered at reasonable cost, the old real-time scope can often fill the bill.

On sampling scopes and single-shots

Sampling scopes were designed to extend the frequency ranges of oscilloscopes into the microwave region. Unlike real-time scopes, which produce a complete image with each sweep of the electron beam (and thus must be able to deflect the beam in real time), sampling scopes build up their displays from a series of samples taken on successive sweeps. On the first sweep, a sample-and-hold circuit measures and stores the voltage level of the input signal at a well-defined time after the start of the sweep. On each successive sweep, the delay from the start of the sweep to the moment of sampling is increased slightly, resulting in the collection of a series of samples that can be compiled to reconstruct the input waveform (see illustration).

Since the reconstructed waveform is put together from a collection of discrete samples, it is a dotted display—a fact with both positive and negative implications. First, the bad news: a dotted display lacks the resolution and visual appeal of a continuous display. And it is never certain that the highest dot on the screen represents the peak voltage of your waveform.

Now, the good news: since each dot represents a sample taken a well-defined length of time after the sample represented by the preceding dot, simply counting the dots between two points on a waveform is an accurate way of measuring the time interval between those points.

Since the display of a sampling scope does not have to keep up with the input signal in real time, it places no restrictions on the bandwidth of the signals it can handle. In fact, the bandwidth of a sampling scope is limited only by the width of the sample-and-hold strobe window, and on the fineness with which the incremental delay can be stepped. At the present state of technology, these limitations translate into a maximum frequency of about 18 GHz, which corresponds to a rise time of about 20 picoseconds.

A single-shot module is similar in concept to the sample-and-hold circuitry of a sampling scope. It has two inputs: one for the trigger and one for the signal to be measured. It also has provision for manually adjusting or remotely programming a variable delay.

After receiving a trigger input, the single-shot waits the selected delay time, and then quickly opens and closes a

fast FET sampling gate. The voltage sample thus obtained is then amplified, if necessary, and stretched to a length suitable for processing by external equipment. Typically, the output signal is a pulse with a duration of about a millisecond.

Obviously, if the input signal is repetitive and the single-shot module is suitably programmed, it can serve the same function as a sampling scope.

This single-shot module is sometimes called a strobing voltmeter. A second type, primarily meant for the measurement of time intervals, is called a switching time converter. This second type of single-shot uses a pair of variable-threshold detectors to define the time interval to be measured.

As the input signal crosses the threshold of the first detector, a constant-current source starts charging a fixed capacitor. When the input signal crosses the second threshold, the current is stopped. The voltage on the capacitor is therefore a measure of the time the input signal spent between the two thresholds.

Buffering circuitry transfers this voltage to the module's output as the amplitude of a 1-millisecond pulse—a pulse duration easily handled by most any a-d converter.

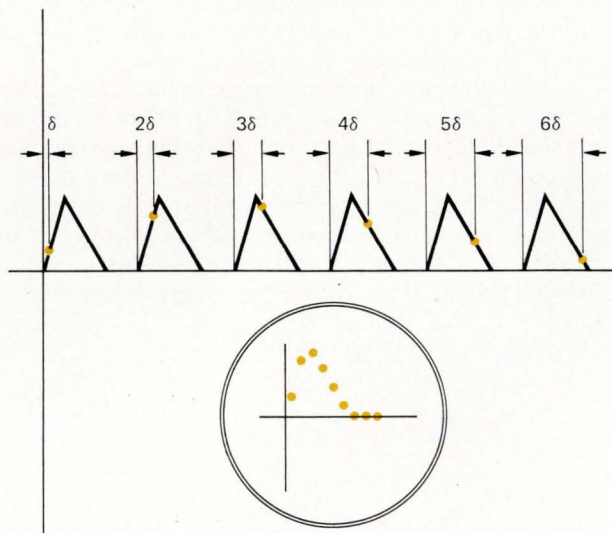

cations, this noise consideration alone could make the single-shot the instrument of choice.

The digital-readout question

When an oscilloscope is used for production-line testing, the usual procedure is to mask off acceptance bands on the faceplate with strips of tape or write them in with a grease pencil. The operators simply use their eyes to ensure that the traces they see are within the defined acceptance limits.

When working with fast pulses, this technique can result in errors on the order of 5% to 10%. If this degree of accuracy is acceptable for a given application (it is for many), and if the maximization of throughput isn't too important, this approach is ideal. It's cheap, and it works.

If, however, high accuracy and/or high throughput are needed, an instrument that provides a digital read-

out must be considered. All single-shot modules, by their very nature, provide a digital output. Some sampling scopes made by E-H/AMC and Tektronix are available with digital readout, although, since most of them are primarily intended for systems use, they can be quite expensive. An exception is the E-H/AMC 1100, a benchtop version of the programmable model 1010, which sells for \$7,900.

With one exception, no available real-time scopes provide digital output. The exception is the Tektronix digital processing oscilloscope, which uses a mini-computer to generate its digital output information. This scope is not directly comparable to anything else on the market. Its high price and extensive computational abilities make it difficult to discuss in terms of a general bench instrument.

When maximizing throughput is of prime importance, not only must the measurement tool provide a

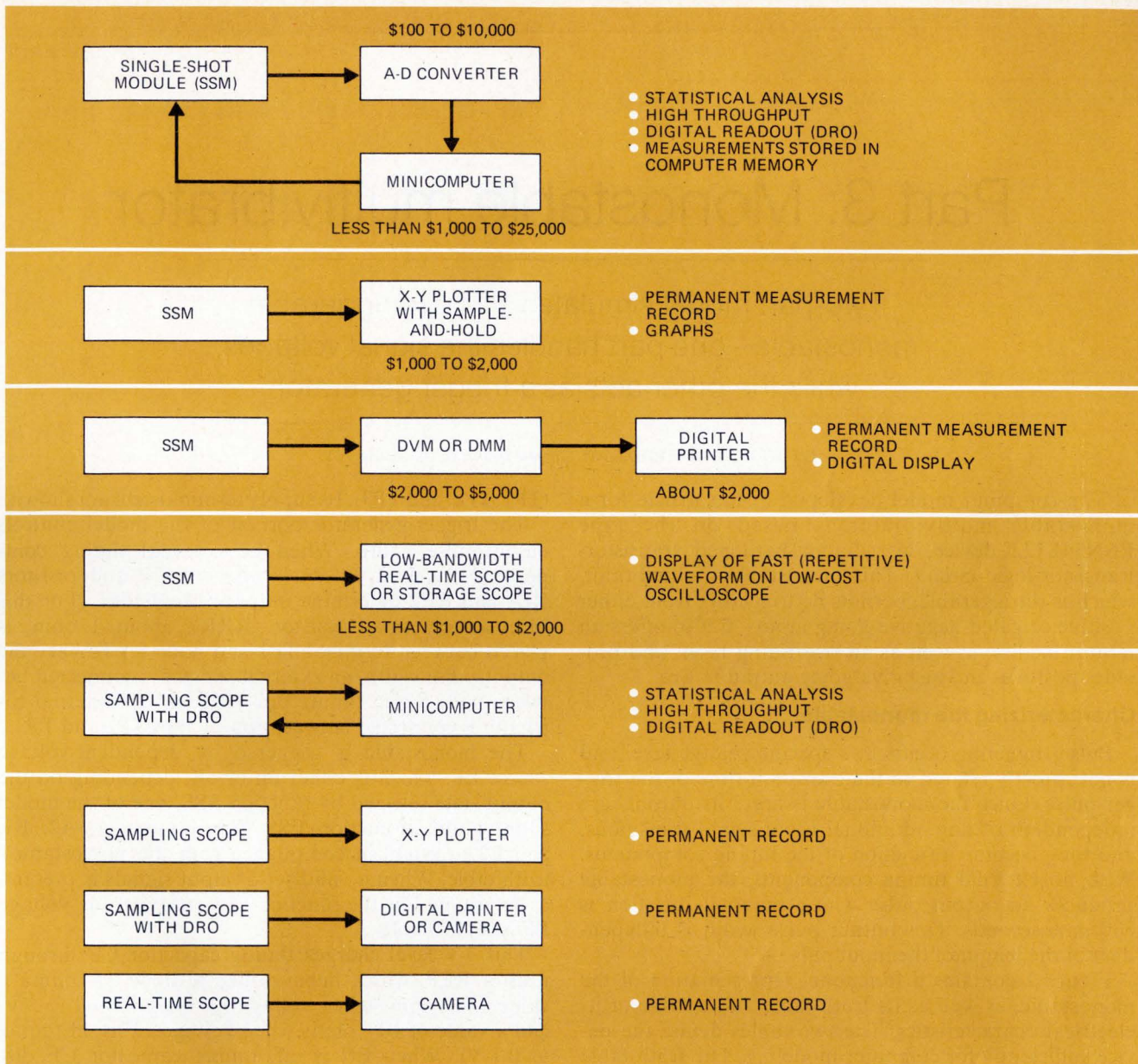

2. Systems. Measurements on fast pulses are seldom made by a single stand-alone instrument. Various systems, providing everything from permanent records to statistical analyses, can be set up at prices ranging from less than \$5,000 to more than \$40,000.

digital output, it must also be capable of being controlled by digital inputs. No real-time scopes fall into this category, but all single-shots do, as do several sampling scopes.

Because programable instruments are very expensive, they tend to be used mostly for very high-volume production. However, at least two other reasons may persuade an engineer to go for full automation.

Choosing automation

One is repeatability. A fully automated system eliminates human errors in both the setup of a test and the readout of its results. Digital readout alone solves only half the problems; even the best technicians cannot be sure of resetting the dials on a generator to exactly the same positions used on a previous test. And if the errors that may result from this type of human failing cannot be tolerated, a fully automated system may be justified.

Moreover, automation saves time when many measurements must be made at different points on a device. Checking out a 40-pin LSI device is a good example. Each individual measurement may be extremely easy to make, but it doesn't make sense to tie a man up all day switching probes around, even on a fairly low-volume line. Hence, the automated system's ability to multiplex many probes may be the main reason for buying it.

The need to make measurements on fast pulses, together with the recent introduction of many new measuring tools, has presented the engineer with both a new burden and a new opportunity. He must know precisely what his present needs are and his future needs are likely to be so that he can make an intelligent decision on the purchasing of hardware for fast waveform measurements. As his reward at the end of a long decision path, he is likely to acquire an excellent instrument—that will serve him well for years to come. □

Part 3: Monostable multivibrator

Two-part model simulates a TTL retriggerable monostable—one part handles the signal voltages, while the other acts as a trigger generator

by John R. Greenbaum, *General Electric Co., Syracuse, N.Y.*

□ The computer model developed in this article for a monostable multivibrator is based on the type RSN54L122 device, a radiation-hardened transistor-transistor-logic circuit. This monostable multivibrator, which is retriggerable, permits dc triggering from either positive or gated negative-going inputs. It also offers an inhibit facility, as well as an overriding reset, and provides positive- and negative-going output pulses.

Characterizing the monostable

Pulse-triggering occurs at a specific voltage level and is not directly related to the transition time of the trigger pulse. Once the monostable is fired, its outputs are independent of any additional input-signal transitions, and they become a function of the timing components. With no external timing components, the monostable produces an output pulse whose nominal duration is 800 nanoseconds. This output pulse width is independent of the length of the input pulse.

Figure 1 contains a functional representation of the monostable, as well as its truth table and a table of its electrical characteristics. The two tables define the device sufficiently for computer modeling. The truth table describes the monostable's behavior when its reset input is high (logic 1).

The A1 and A2 trigger inputs, which respond to the negative-going edge of a logic input, fire the monostable if either or both of them go to logic 0 when the B1 and B2 inputs are at logic 1. The latter two trigger inputs are positive Schmitt-trigger inputs for handling slow-rising signals or level-detection. These inputs trigger the monostable when either of them goes to logic 1, while the remaining B input is at logic 1 and either the A1 or A2 input is at logic 0.

Developing the model

A two-part model is needed to simulate the performance of the RSN54L122 monostable. Figure 2 shows this model, along with the associated Sceptre (System for Circuit Evaluation and Prediction of Radiation Effects) and Circus-2 (CIRCUit Simulator) model descriptions and subprograms. The model has four trigger inputs (A1, A2, B1, and B2), a reset (RS) input, complementary outputs (Q and QB), and timing pins

(TP1, TP2, and TP3). Its supply terminals are not shown.

The trigger-generator portion of the model controls output-pulse width. When no external timing components are used, internal capacitor CF and resistors RF1 and RF2 determine output-pulse width. (For this case, a very small resistor (RRR), about 1 ohm, is placed between terminal TP1 and node 8.) To vary the output-pulse width, an external resistor is connected between node 8 and timing pin TP2, and an external capacitor is connected between timing pins TP2 and TP3.

The monostable is triggered by dependent-voltage source EF, which is either on or off, depending on the output state selected by function FSS, one of the model subprograms. Function FSS tests inputs A1, A2, B1, and B2 to establish compliance with the monostable's truth table. When a valid set of input signals is present, as determined by the function FIN subprogram, voltage EF is set to 3 volts.

This 3-v level charges timing capacitor CF through resistor RFF, which behaves like a diode, assuming a value of 10 ohms when voltage EF is on (equal to 3 v) and a value of 10^{20} ohms when voltage EF is off (equal to 0.1 v). When EF is off, timing capacitor CF discharges through timing resistors RF1 and RF2.

These two resistors represent the monostable's internal-resistance circuit. One part (RF1) of the resistance circuit is always in series with capacitor CF, while the other part (RF2) is effective only when no external timing components are used. The two parts are needed to simulate monostable performance accurately, regardless of whether or not external timing components are used. Resistors RRR and RRF are added to the model to

This article is the third in a five-part series on simplified, but accurate, computer models for common digital ICs. The models are developed on the basis of device terminal behavior, instead of the classical method of modeling every transistor and diode junction in the IC. The NAND gate was covered in Part 1 in the Dec. 6 issue, and the flip-flop in Part 2 in the Dec. 20 issue. In future issues, the AND/OR inverter and the shift register will be discussed.

FIG. 1 MULTIVIBRATOR DATA

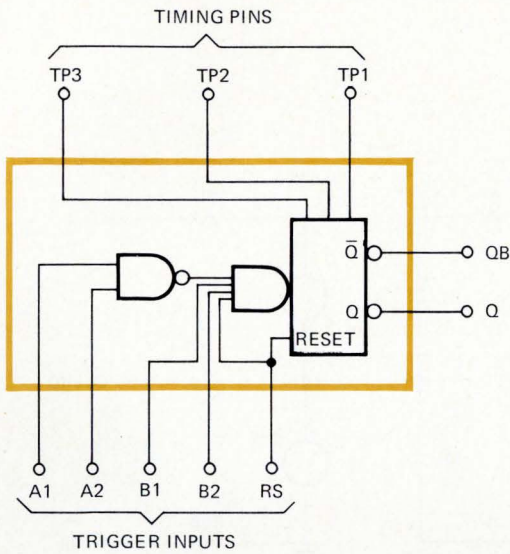

TRUTH TABLE					
Input				Output	
A1	A2	B1	B2	Q	\bar{Q}
H	H	X	X	L	H
X	X	L	X	L	H
X	X	X	L	L	H
L	X	H	H	L	H
L	X	↑	H	[one high-level pulse]	[one low-level pulse]
L	X	H	↑	[one high-level pulse]	[one low-level pulse]
X	L	H	H	[one high-level pulse]	[one low-level pulse]
X	L	↑	H	[one high-level pulse]	[one low-level pulse]
X	L	H	↑	[one high-level pulse]	[one low-level pulse]
H	↓	H	H	[one high-level pulse]	[one low-level pulse]
↓	↓	H	H	[one high-level pulse]	[one low-level pulse]
↓	H	H	H	[one high-level pulse]	[one low-level pulse]

H = high level
 L = low level
 ↑ = transition from low to high level
 ↓ = transition from high to low level

[one high-level pulse] = one high-level pulse
 [one low-level pulse] = one low-level pulse
 X = any input, including transition

ELECTRICAL CHARACTERISTICS

Parameter	Conditions	Minimum	Typical	Maximum
$V_{in(1)}$	Logic 1 input voltage required at any input terminal	$V_{CC} = 4.5 \text{ V}$	1.9 V	
$V_{in(0)}$	Logic 0 input voltage required at any input terminal	$V_{CC} = 4.5 \text{ V}$		0.8 V
$V_{out(1)}$	Logic 1 output voltage at positive or negative output with logic 1 level at positive or negative input terminal, respectively.	$V_{CC} = 4.5 \text{ V}, V_{in} = 1.9 \text{ V}$ $I_{load} = -100 \mu\text{A}$	2.4 V	
$V_{out(0)}$	Logic 0 output voltage at positive or negative output with logic 0 at positive or negative input, respectively.	$V_{CC} = 4.5 \text{ V}, V_{in} = 0.8 \text{ V}$ $I_{sink} = 2 \text{ mA}$		0.3 V
$I_{in(0)}$	Logic 0 level input current	$V_{CC} = 5.5 \text{ V}, V_{in} = 0.3 \text{ V}$		-0.18 mA
$I_{in(0)}$	Logic 0 level reset current	$V_{CC} = 5.5 \text{ V}, V_{in} = 0.3 \text{ V}$		-0.38 mA
$I_{in(1)}$	Logic 1 level input current	$V_{CC} = 5.5 \text{ V}, V_{in} = 2.4 \text{ V}$ $V_{CC} = 5.5 \text{ V}, V_{in} = 5.5 \text{ V}$		10 μA 0.10 mA
$I_{in(1)}$	Logic 1 level reset current	$V_{CC} = 5.5 \text{ V}, V_{in} = 2.4 \text{ V}$ $V_{CC} = 5.5 \text{ V}, V_{in} = 5.5 \text{ V}$		20 μA
I_{OS}	Short-circuit output current	$V_{CC} = 5.5 \text{ V}$	1 mA	-15 mA
I_{CC}	Quiescent power-supply drain	$V_{CC} = 5.5 \text{ V}$	3.5 mA	
t_{pd}	Negative trigger input to negative output	$V_{CC} = 5.0 \text{ V}$ Load = 15 pF Connect V_{CC} to pin TP1		300 ns
$t_{pw(min)}$	Minimum true output-pulse width	$V_{CC} = 5.0 \text{ V}$ Load = 15 pF Connect V_{CC} to pin TP1	800 ns	

FIG. 2 MODELING THE MULTIVIBRATOR

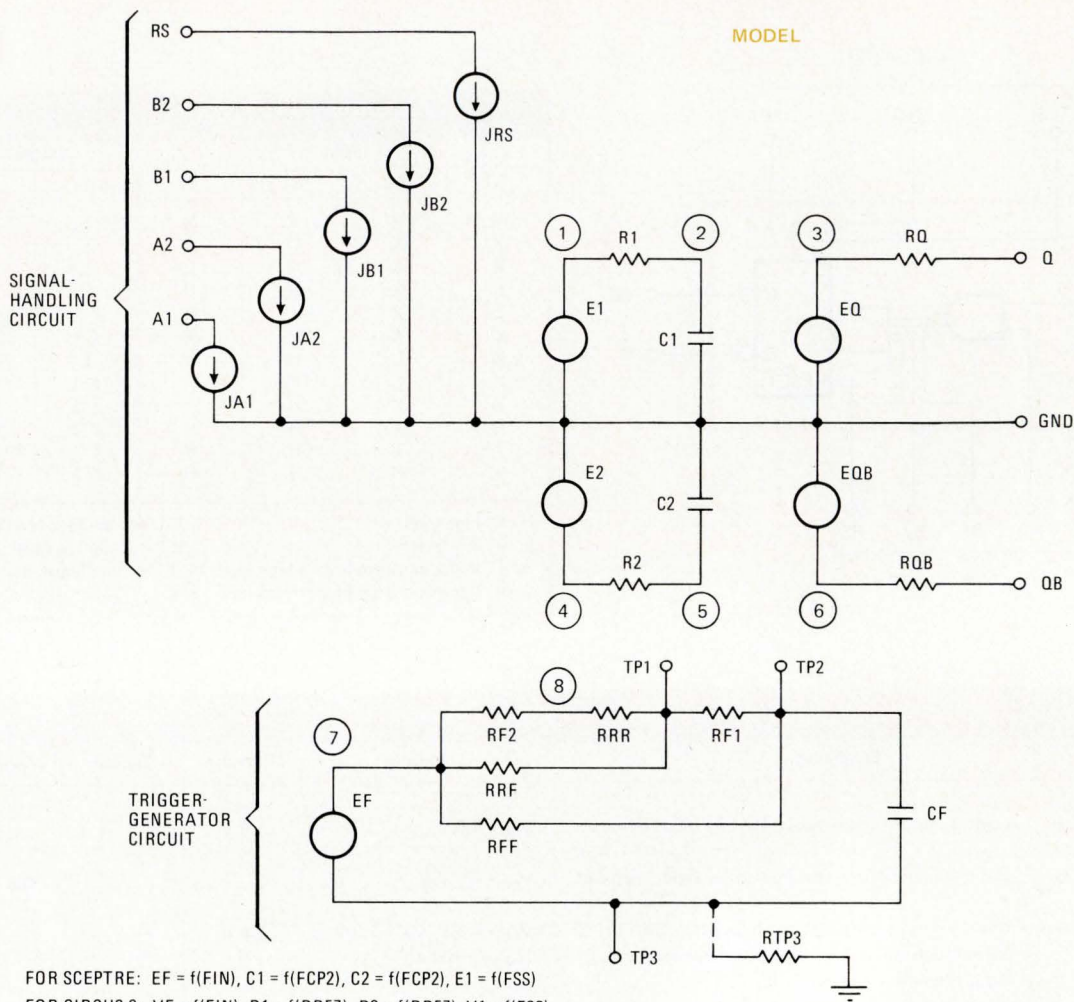

FOR SCEPTRE: $EF = f(FIN)$, $C1 = f(FCP2)$, $C2 = f(FCP2)$, $E1 = f(FSS)$
 FOR CIRCUS-2: $VF = f(FIN)$, $R1 = f(RR57)$, $R2 = f(RR57)$, $V1 = f(FSS)$

SCEPTRE DESCRIPTION

MODEL RSN54L122 (A1-A2-B1-B2-RS-8-TP1-TP2-TP3-Q-QB-GND)
 MONOSTABLE MULTIVIBRATOR

ELEMENTS

JA1,A1-GND=0.
 JA2,A2-GND=0.
 JB1,B1-GND=0.
 JB2,B2-GND=0.
 JRS,RS-GND=0.
 EF,TP3-7=Q1(VJA1,VJA2,VJB1,VJB2,TIME,EF,VJRS)
 RRF,7-TP1=1.E20
 RF1,TP1-TP2=33.E3
 RF2,7-8=7.E3
 RRR,8-TP1=1.E20
 RFF,7-TP2=T1(EF)
 CF,TP2-TP3=25.E-12
 E1,GND-1=Q2(VCF,VJRS)

$R1,1-2=1000.$
 $C1,2-GND=Q3(E1,VC1)$
 $EQ,GND-3=X1(VC1)$
 $RQ,3-Q=100.$
 $E2,GND-4=X2(3.1-E1)$
 $R2,4-5=1000.$
 $C2,5-GND=Q3(E2,VC2)$
 $RQB,6-QB=100.$
 $EQB,GND-6=X3(VC2)$

FUNCTIONS

Q1(A,B,C,D,E,F,G) = (FIN(A,B,C,D,E,F,G))
 Q2(A,B) = (FSS(A,B))
 Q3(A,B) = (FCP2(A,B))

T1 = 0., 1.E20, 0.8, 1.E20, 2., 10., 3., 10.

OUTPUTS
 VJF,PLOT

avoid program difficulties for those situations where voltage source EF is dependent upon itself.

In the signal portion of the model, dependent-voltage source E1 is high (3 v) when the voltage across capacitor CF is greater than 1.5 v. Voltage source E2 is simply the complement of voltage source E1. The appropriate delays for outputs Q and QB are computed in function

FCP2, another model subprogram. The delays are controlled by time constants R1-C1 and R2-C2 for Q and QB, respectively. Function FCP2 selects the correct linear capacitor equation, depending on whether capacitor voltage is rising or falling.

The two dependent-voltage sources at the output, EQ and EQB, isolate the model's frequency-sensitive RC

FIG. 2 CONTINUED

CIRCUS-2 DESCRIPTION

MODELS
 MODEL NAME = MONOSTABLE MULTIVIBRATOR
 EXTERNAL NODES = (A1,A2,B1,B2,RS,8,TP1,TP2,TP3,Q,QB,GND)
TOPOLOGY
 JA1,A1,GND
 JA2,A2,GND
 JB1,B1,GND
 JB2,B2,GND
 JRS,RS,GND
 RTP3,TP3,GND
 VF,7,TP3
 RRF,7,TP1
 RF1,TP1,TP2
 RF2,7,8
 RRR,8,TP1
 RFF,7,TP2
 CF,TP2,TP3
 V1,1,GND
 R1,1,2
 C1,2,GND
 VQ,3,GND
 RQ,3,Q
 V2,4,GND
 R2,4,5
 C2,5,GND
 RQB,6,QB
 VQB,6,GND

EQUATIONS
 $VF = FIN(V.JA1,V.JA2,V.JB1,V.JB2,T,VF,V.JRS)$
 $D(VF,T) = 1.$
 $R1 = RR57(V1,V.C1,130,5,D(R1,V.C1))$
 $R2 = RR57(V2,V.C2,130,5,D(R2,V.C2))$
 $RFF = TABLE RF(VF,DX,DRFF)$
 $V2 = (3.1-V1)$
 $D(V2,V1) = 1.$
 $VQ = V.C1$
 $D(VQ,V.C1) = 1.$
 $VQB = V.C2$
 $D(VQB,V.C2) = 1.$
 $V1 = FSS(VF,V.JRS)$
 $D(V1,T) = 0.$
 RETURN
 END
END OF INPUT
DEVICES
 DEVICE NAME = RSN54L122, MODEL NAME = MONOSTABLE MULTIVIBRATOR
SINGLE-VALUED PARAMETERS
 $JA1=0., JA2=0., JB1=0., JB2=0., JRS=0., RTP3=1.E20,$
 $RRF=1.E20, RF1=33.E3, RF2=7.E3, RRR=1.E20,$
 $CF=25.E-12, C1=1000E-12, C2=1000E-12,$
 $RQ=100, RQB=100$
ONE-DIMENSIONAL TABLES
 $RF, (0,0,8,2,3), (1.E20,1.E20,10,10)$
 END OF INPUT

MODEL SUBPROGRAMS

```

1 CFIN      FOR MONOSTABLE MULTIVIBRATOR
2          FUNCTION FIN(A1,A2,B1,B2,TIME,XFIN,RS)
3 C        TIMING CIRCUIT TRIGGER GENERATOR
4 C
5          IF(TIME.LE.0.OR.RS.LE.1.5) GO TO 40
6          IF(TIME.LE.XTIME) GO TO 60
7          DA1=A1-XA1
8          DA2=A2-XA2
9          DB1=B1-XB1
10         DB2=B2-XB2
11         IF((A1.LE.1.5.AND.ABS(DA1).LE.0.1).OR.(A2.LE.1.5.AND.
12         *ABS(DA2).LE.0.1)) GO TO 20
13         GO TO 25
14         20 IF((DB1.GT.0.AND.B1.GT.1.3.AND.B1.LT.1.7.AND.B2.GT.1.5).OR.
15         *(B1.GE.1.5.AND.DB2.GT.0.AND.B2.GT.1.3.AND.B2.LT.1.7)) GO TO 35
16         25 IF((B1.GE.1.5.AND.ABS(DB1).LE.0.1).AND.(B2.GE.1.5.
17         *AND.ABS(DB2).LE.0.1)) GO TO 30
18         GO TO 40
19         30 IF((A1.GE.1.5.AND.ABS(DA1).LE.0.1).AND.(DA2.LT.0.AND.A2.GT.
20         *1.3.AND.A2.LT.1.7)) GO TO 35
21         IF((DA1.LT.0.AND.A1.GT.1.3.AND.A1.LT.1.7).AND.(A2.GE.1.5
22         *AND.ABS(DA2).LE.0.1)) GO TO 35
23         IF(DA1.LT.0.AND.A1.GT.1.3.AND.A1.LT.1.7.AND.DA2.LT.0.AND.
24         *A2.GT.1.3.AND.A2.LT.1.7) GO TO 35
25         GO TO 40
26         35 FIN = 3.0
27         GO TO 50
28         40 FIN = 0.1
29         50 XTIME = TIME
30         XA1 = A1
31         XA2 = A2
32         XB1 = B1
33         XB2 = B2
34         RETURN
35         60 FIN = XFIN
36         RETURN
37         END
  
```

```

1 CFCP2     MULTIVIBRATOR CAPACITOR SELECTION
2          FUNCTION FCP2(VGEN,VCAP)
3 C        FOR USE WITH RSN54L122
4          IF(VGEN-VCAP) 100,110,110
5          110 FCP2=-100.E-12+VCAP/3.+130.E-12
6          RETURN
7          100 FCP2=35.E-12+VCAP/3.+5.E-12
8          RETURN
9          END
  
```

```

1 CFSS     MODEL RSN54L122 MONOSTABLE MULTIVIBRATOR SUBPROGRAM
2          FUNCTION FSS(VF,RS)
3 C        MODEL RSN54L122 MONOSTABLE MULTIVIBRATOR SUBPROGRAM
4 C        NOTE: RS=RESET VOLTAGE
5 C        OUTPUT STATE GENERATOR
6 C
7 C
8          FSS=0.1
9          IF(VF.GT.1.5) FSS=3.0
10         IF(RS.LT.1.5) FSS=0.1
11         RETURN
12         END
  
```

circuits from the effects of external loading. Resistors RQ and RQB represent the monostable's output impedance and are set equal to 100 ohms.

As previously mentioned in the first two parts of this series of computer-aided-design articles, it is convenient to adjust model time delays in the Circus-2 program by varying resistance, rather than capacitance. Instead of the function FCP2 subprogram used in the Sceptre model description, the Circus-2 program listing calls for

subprogram RR57. In this way, resistors R1 and R2, not capacitors C1 and C2, are varied to obtain the proper time delay for the model.

Additionally, resistor RTP3 is added to the trigger-generator portion of the model because Circus-2 cannot accept two-part models. Resistor RTP3 is connected from timing pin TP3 to ground and is set equal to 10^{20} ohms, a value that is large enough to be considered as an effective open circuit. □

Impedance simulator provides wideband test loads

Technique makes possible construction of general-purpose loads that simulate all complex impedances over decade bandwidths and more; applications vary widely from audio to microwave frequency ranges

by Louis W. SIMON, Cincinnati Electronics Corp., Cincinnati, Ohio

□ The use of resistive dummy loads in the design and testing of electronic equipment is common. Not so common, however, are general-purpose dummy loads that can simulate complex impedances. The need for such loads often crops up in situations that range from experiments with audio equipment to production-testing of rf transmitters.

But now, for these and similar applications, a technique has been developed to simulate all impedances within a Smith-chart circle at voltage-standing-wave ratios from 1 to over 50 and at decade and larger bandwidths. To obtain the desired loads, impedance is adjusted by three non-interacting controls. One control adjusts the VSWR magnitude between the circuit and the load; the other two controls adjust the voltage-reflection angle. The load simulator, for which a patent is being sought, is analogous to the popular resistance-substitution box, except that a complex impedance having both resistive and reactive components can be selected.

A generalized circuit for the complex load simulator is shown in Fig. 1. The simulator contains only three basic variable components. Inspection of a Smith-chart plot of such a circuit with data for a hypothetical ideal load (Fig. 2) illustrates the straightforward operating principle of the device. The Smith-chart plots are for the impedances at the input port of the circuit of Fig. 1.

The circles of constant VSWR magnitude in Fig. 2 are obtained by selecting either a series or parallel configuration of inductance and capacitance, then varying the reactive component. The radial line of constant VSWR angle is obtained by adjusting the variable attenuator. By properly selecting the attenuation and setting of reactance, virtually any point on the Smith chart can be simulated. Careful design techniques, coupled with the use of high-quality components and construction, provide a general-purpose load covering several decades of frequency.

Reactance only

Details of the operation of the circuit in Fig. 1 are best explained by considering the reactive portion of the circuit separately. Also, for the time being, operation at a single frequency is assumed. The range of reactances at the input of a purely reactive circuit, caused by the variation of L and C, lie on the circumference of the Smith chart in Fig. 2.

With the switch positioned for a series LC connec-

tion, as shown, reactances generally lie on the left-hand part of the circumference, passing through the zero impedance point, which occurs at series resonance. When switched for a parallel LC connection, the range of reactance tends to lie on the right-hand part of the circumference, passing through infinite impedance, which occurs at parallel resonance.

For example, in the series-connected circuit, if C is set at minimum capacitance and L at maximum inductance, the maximum inductive reactance results. Likewise, if L is set at minimum inductance and C is set at maximum capacitance, the result is maximum capacitive reactance. A plot of the locus of points for all conditions in between forms the left-hand side of the Smith chart. If L and C are selected so that the inductive and capacitive reactance are equal, the impedance at the input to the reactive circuit is zero.

Similarly, a parallel LC connection allows operation over the right-hand circumference of the chart.

Adding attenuation

The key to operation of the load simulator over points inside the chart's circumference is the addition of the variable attenuator to the L and C circuitry, as shown in Fig. 1. From transmission-line principles, it is known that adding attenuation between a transmission line and a highly mismatched load will result in a lower VSWR at the input of the transmission line.

For an attenuator with an infinite VSWR at its output,

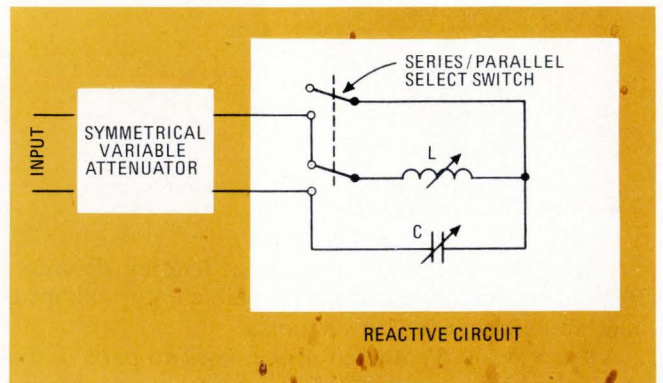

1. A load for all impedances. Only three circuit components are required to simulate any impedance within a Smith-chart circle, shown in Fig. 2. The trick, however, is to choose the right component values to assure operation over a wide range of frequencies.

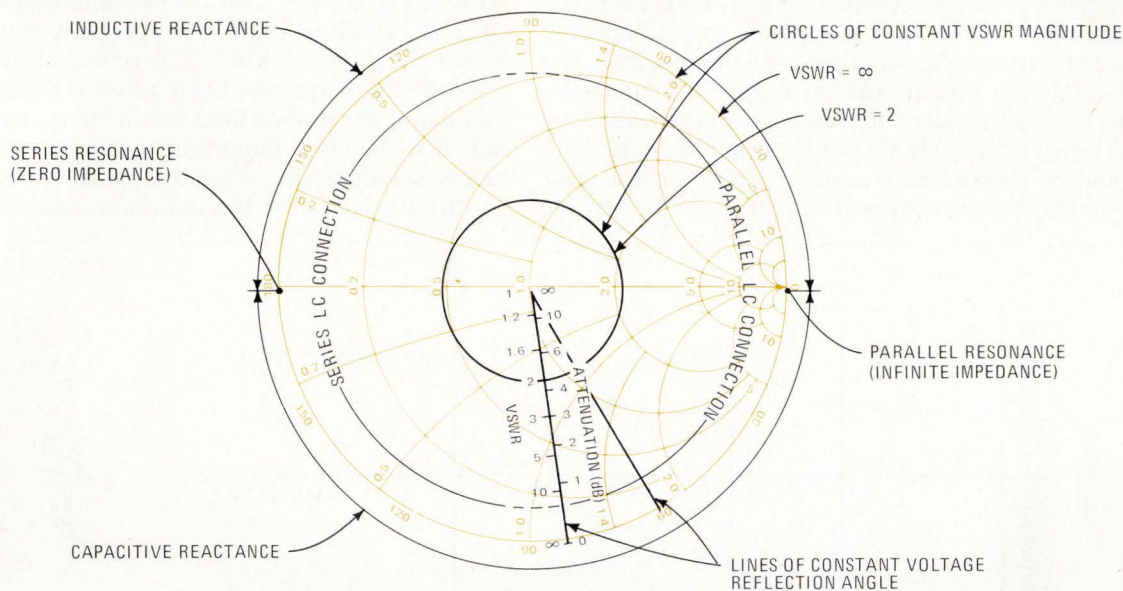

2. Complex-load map. Points along the Smith chart's circumference are simulated by varying the load's reactive components and by selection of either a series or parallel circuit. Points along the chart's radius are simulated by adding attenuation in the resistive component.

it has been shown that the VSWR at its input is calculated as:¹

$$VSWR_{in} = \frac{10^{A/10} + 1}{10^{A/10} - 1}$$

where A is the loss of the attenuator, measured in dB. Thus, if the attenuator in Fig. 1 has an infinite mismatch at its output and is set at 1 dB attenuation, the VSWR at its input is 8.72. Likewise, if A = 15 dB, the input VSWR is only 1.065.

It is therefore apparent that by using a continuously variable attenuator of 0 to 15 dB, the VSWR at the attenuator can be reduced from infinity to 1.065. It can further be shown that for a fixed attenuation, variation of the inductor and capacitor provides an input variable impedance at a constant VSWR. Thus, input impedance on the chart, while varying attenuation, is a radial straight line; the locus of impedances for a constantly varying LC network forms a circle of constant radius.

From this, it can be concluded that by proper selection of components, virtually any impedance on the Smith chart can be realized at the input to the total circuit in Fig. 1. Further, it can also be shown that this entire range of complex impedances can be simulated over a full decade and more of frequency range.

Designing for broadband operation

The design of the universal simulator to cover a specific impedance range and frequency band involves selection of the attenuation range on the variable attenuator and choosing the variable inductor and capacitor values. The selection of the variable attenuator can be independent of the values of inductance and capacitance, while the values of the capacitor and inductor de-

pend on each other, as well as the frequency range.

To show the relation of ranges of L and C to the desired operating frequency range, plots of reactance versus frequency for both series and parallel variable LC circuits are used. First consider the general case of a series-connected variable L and C, as in Fig. 3a.

The lower curve shows the reactance versus frequency for the minimum values of L and C, while the upper curve shows the same for the maximum values of L and C. For any given frequency, as L and C are increased from minimum to maximum, the range of reactances is a vertical line connecting the lower and upper curves. All points between the two curves represent all reactances that can be simulated for the complete range of L and C.

Next, consider the general case of a parallel-connected LC circuit as in Fig. 3b. Here, four curves bound the area within which lie all reactances achievable as a function of frequency. The two discontinuities at f_{01} and f_{02} occur at the parallel resonant frequencies of the maximum L and C values and at their minimum values. The area between the positive reactance curves extends to positive infinity and between the negative reactance curves to negative infinity.

At any given frequency, as L and C are adjusted over their entire range, the range of possible reactances is represented for the series circuit by a line connecting the lower and upper curves as shown. For the parallel-connected LC circuit, this line extends from the lower curve for the positive reactance to positive infinity and returns from negative infinity to the upper curve of the negative reactance. Since the reactive components used for the series and parallel connection are the same, the parallel resonant frequencies (f_{01} and f_{02}) are exactly

equal to the corresponding series-resonant frequencies (the zero-reactance crossover points in Fig. 3a.)

By superimposing plots of both series and parallel circuits as shown in Fig. 3c, it is apparent that all possible reactances can not be simulated when operating between minimum and maximum resonant frequencies, f_{01} and f_{02} . Specifically, the reactances represented by the darkened areas A, B, C, and D cannot be simulated.

As will be shown, the frequency range for full reactance coverage is the narrower of regions defined by in-

tercept points f_1 to f_2 or f_3 to f_4 . The actual values of L and C determine which of the two regions is narrower.

From Fig. 3c, it is seen that a combination of inductors and capacitors could be improperly chosen to produce a circuit that could not be operated over all reactances at any frequency. Such a case is illustrated when considering the dashed lines for an alternative series circuit. It is therefore important to analyze exactly what factors determine the intercept points f_1 , f_2 , f_3 , and f_4 . To do this, let L_1 be the minimum value and L_2 the

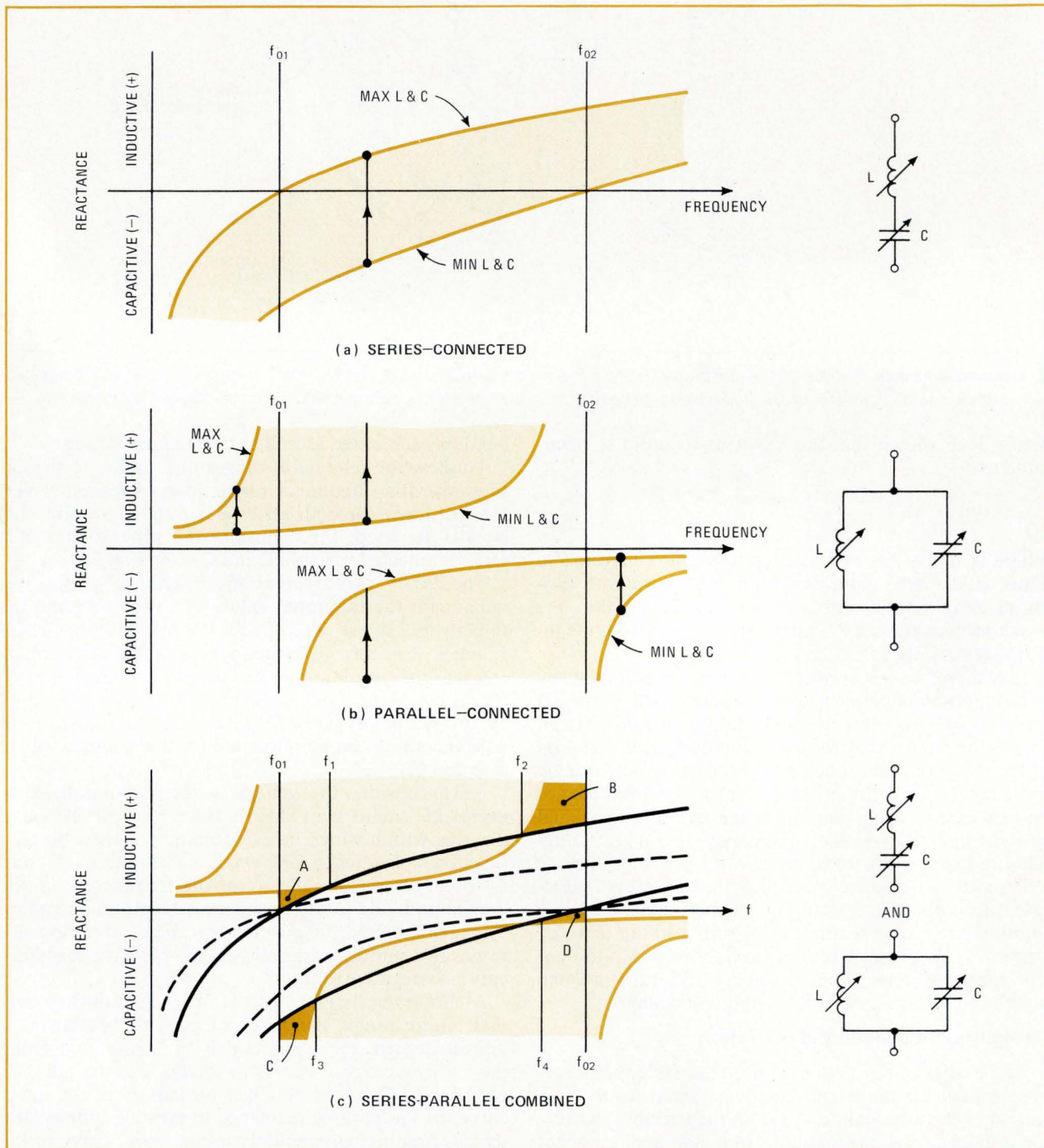

3. Wideband analysis. Plots of reactance as a function of frequency illustrate the bandwidth operating limits of the reactive circuits connected in series (a) and in parallel (b). A plot of the superimposed series and parallel circuits (c) allows the definition of the practical limits of the range of operating frequencies over which the load can be made to simulate all points within the Smith-chart circle.

maximum value of the variable inductance. Also, let C_1 be the minimum value and C_2 the maximum value of the variable capacitance.

In Fig. 3c, frequencies f_1 and f_2 coincide with the points at which the reactance of the series circuit for L_2 and C_2 is equal to the reactance of the parallel circuit for L_1 and C_1 . Similarly, f_3 and f_4 are the frequencies where the reactance of the series circuit for L_1 and C_1 is equal to the reactance of the parallel circuit for L_2 and C_2 . The preceding two statements can be represented as:

$$w_{1,2}L_2 - \frac{I}{w_{1,2}C_2} = \frac{I}{\frac{I}{w_{1,2}L_1} - w_{1,2}C_1} \quad (2)$$

and

$$w_{3,4}L_1 - \frac{I}{w_{3,4}C_1} = \frac{I}{\frac{I}{w_{3,4}L_2} - w_{3,4}C_2} \quad (3)$$

where $\omega = 2\pi f$ and the double subscript indicates that the equation holds at both frequencies.

Equation 2 can be rearranged as:

$$w_{1,2}^4 - w_{1,2}^2 \left(\frac{I}{L_1C_1} + \frac{I}{L_2C_2} - \frac{I}{L_2C_1} \right) + \frac{I}{L_1C_1L_2C_2} = 0 \quad (4)$$

and Eq. 3 as:

$$w_{3,4}^4 - w_{3,4}^2 \left(\frac{I}{L_1C_1} + \frac{I}{L_2C_2} - \frac{I}{L_1C_2} \right) + \frac{I}{L_1C_1L_2C_2} = 0 \quad (5)$$

The fourth power in Eqs. 4 and 5 indicates that four solutions exist for frequency. Two of the solutions are negative. The other two are the intercept points for the solid line curves of Fig. 3c. If the minimum and maximum values of the reactive components are improperly chosen to produce the dashed curves of Fig. 3c for the series circuit, all four solutions are imaginary, as would be expected. The four frequencies f_1 , f_2 , f_3 , and f_4 of Fig. 3c can now be found from Eqs. 4 and 5 as:

$$w_1 = \left[\frac{1}{2} \left(\frac{I}{L_1C_1} + \frac{I}{L_2C_2} - \frac{I}{L_2C_1} \right) - \frac{1}{2} \sqrt{\left(\frac{I}{L_1C_1} + \frac{I}{L_2C_2} - \frac{I}{L_2C_1} \right)^2 - \frac{4}{L_1C_1L_2C_2}} \right]^{\frac{1}{2}} \quad (6)$$

$$w_2 = \left[\frac{1}{2} \left(\frac{I}{L_1C_1} + \frac{I}{L_2C_2} - \frac{I}{L_2C_1} \right) + \frac{1}{2} \sqrt{\left(\frac{I}{L_1C_1} + \frac{I}{L_2C_2} - \frac{I}{L_2C_1} \right)^2 - \frac{4}{L_1C_1L_2C_2}} \right]^{\frac{1}{2}} \quad (7)$$

$$w_3 = \left[\frac{1}{2} \left(\frac{I}{L_1C_1} + \frac{I}{L_2C_2} - \frac{I}{L_1C_2} \right) - \frac{1}{2} \sqrt{\left(\frac{I}{L_1C_1} + \frac{I}{L_2C_2} - \frac{I}{L_1C_2} \right)^2 - \frac{4}{L_1C_1L_2C_2}} \right]^{\frac{1}{2}} \quad (8)$$

$$w_4 = \left[\frac{1}{2} \left(\frac{I}{L_1C_1} + \frac{I}{L_2C_2} - \frac{I}{L_1C_2} \right) + \frac{1}{2} \sqrt{\left(\frac{I}{L_1C_1} + \frac{I}{L_2C_2} - \frac{I}{L_1C_2} \right)^2 - \frac{4}{L_1C_1L_2C_2}} \right]^{\frac{1}{2}} \quad (9)$$

Note that Eqs. 6 and 8 are identical, except for the third term within each parenthetical expression. The same applies to Eqs. 7 and 9. Setting the third term of Eq. 6 equal to the third term of Eq. 8 gives $C_2/C_1 = L_2/L_1$. For this condition, $f_1 = f_3$, $f_2 = f_4$, and the range of frequencies for coverage of all reactances is f_1 to f_2 .

It can further be shown that for C_2/C_1 greater than L_2/L_1 , f_4 is greater than f_2 , and f_1 is greater than f_3 . Here, the range of frequencies for full coverage of all reactances is f_1 to f_2 . Similarly, for C_2/C_1 less than L_2/L_1 , the range of frequencies for full coverage is f_3 to f_4 .

Solution of Eqs. 4 and 5 for the range of frequencies for full coverage yields useful information only after the range of values of L and C are known. In practice, however, the situation would more likely be the reverse; that is, the frequency range of operation is known, and the values for L_1 , L_2 , C_1 , and C_2 are to be determined. From only two known quantities—the upper and lower operating frequencies—and Eqs. 4 and 5, the four unknowns can not be determined. However, if L_1 and C_1 are assumed, simultaneous solutions of Eqs. 4 and 5 would yield solutions for L_2 and C_2 —the required maximum values. Eqs. 4 and 5 lead to solutions involving quadratic equations and become quite cumbersome.

Instead, if certain assumptions are made about the desired frequency coverage, useful approximations for reactive-component values can be developed from Eqs. 6 through 9. In general, if a large frequency range of operation is desired for full reactance coverage, then wide ranges of impedance and capacitance must be chosen for the reactive components. It can be shown that if L_2/L_1 and C_2/C_1 are greater than 5, Eqs. 6 through 9, with an approximation error of less than 13%, reduce to

$$w_1 \simeq w_3 \simeq \frac{I}{\sqrt{L_2C_2}} \quad (10)$$

and

$$w_2 \simeq w_4 \simeq \frac{I}{\sqrt{L_1C_1}} \quad (11)$$

Design for decade in frequency

A numerical example will show the use of Eqs. 10 and 11 to determine the range of values for L and C when the frequency range is given. For this example, let $f_1 = 1$ MHz and $f_2 = 10$ MHz. Assume 30 pF (stray and minimum) capacitance for C_1 . Then from Eq. 11:

$$L_1 = \frac{I}{(2\pi f_2)^2 C_1} = 8.44 \mu H \quad (12)$$

As a first cut, also let $C_2 = 150$ pF. Then from Eq. 10:

$$L_2 = \frac{I}{(2\pi f_1)^2 C_2} = 168.9 \mu H \quad (13)$$

Next, compute exact values of frequencies for the intercept points. From Eqs. 6 thru 9, $f_1 = 1.026$ MHz; $f_2 = 9.744$ MHz; $f_3 = 1.12$ MHz; and $f_4 = 8.98$ MHz.

From these calculations and by referring to Fig. 3c, it is seen that frequencies f_3 and f_4 define the limits over which the load may be operated for full impedance coverage. This is what was expected for the condition of C_2/C_1 less than L_2/L_1 . In fact, f_1 and f_2 need not have been calculated.

Note also that the exact solutions of f_3 and f_4 show that the actual range of 1 to 10 MHz would not be achieved with the L and C range, as calculated by the approximate Eqs. 10 and 11. To offset this error, L_2 and C_2 can be increased and L_1 decreased by say, 20%, and the effect on f_3 and f_4 calculated. All relevant values for

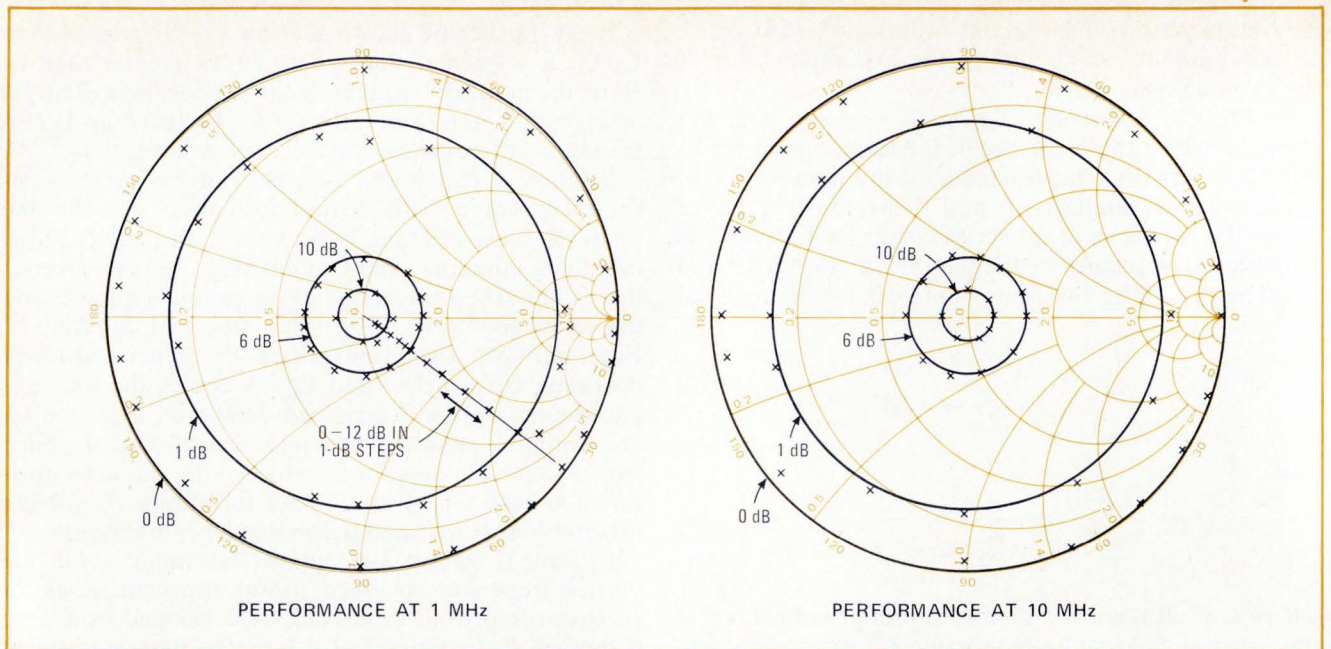

4. Experimental load. Performance of the test load has been measured at 1 MHz (left) and at 10 MHz (right). Points falling around the perimeter of the Smith chart are set by varying reactance values while maintaining a 0-dB setting of the attenuator. Points along the radial lines within the Smith chart's perimeter are set by varying the attenuator's loss between 0 and 12 dB.

the first iteration and for the modified case are compared in the table.

For the modified case, the full range of 0.91 to 10.2 MHz is covered. Again, the limiting frequencies are f_3 and f_4 , since C_2/C_1 is less than L_2/L_1 .

In the above example, if a variable inductor of 6.75 to 202.7 μH is unavailable or impractical, the range of inductance can be increased so that the range of inductance can be reduced. For instance, if C is 30 to 2,000 pF, the inductance range required for full-frequency operation is calculated to be 8.44 to 12.66 μH .

A test unit has been built to use values of 0.05 to 12 μH for the inductor and 20 to 2,000 pF for the capacitor. A variable attenuator of 0 to 12 dB in 1-dB steps was used in a circuit as configured in Fig. 1. Including the effects of stray capacitance and wiring inductance, the effective range of L and C was measured to be around 0.5 to 12.5 μH and 30 to 2,000 pF, respectively. For these ranges, the approximate frequency range is calculated to be 1.0 to 41 MHz. In Fig. 4, test results of the unit are shown for frequencies of 1 and 10 MHz.

Further considerations

In addition to the preceding techniques, the effects of stray and loss components of the attenuator, inductor, and capacitor do not affect circuit operation, except to reduce the effective ratios C_2/C_1 and L_2/L_1 and to in-

roduce secondary resonant conditions outside the frequency range of interest. The effect of the addition of resistive loss to L, C, and the variable attenuator (for 0-dB setting) is to reduce the maximum available VSWR. In other words, any unwanted resistance in the circuit causes the maximum available VSWR circle to be less than the outer circle of the Smith chart.

Although circuit analysis becomes quite complex with the introduction of strays and loss components, approximate circuits can be used to handle the first-order effects. The maximum available VSWR can be estimated at series and parallel resonance conditions for various values of L and C. Generally, the loss associated with the capacitor will be much less than that of the inductor. Therefore, in selection of L and C, the range of C should be selected to be as wide as possible, so that the range of values of the inductance can be small. In this way, the value of series resistance (for a given inductor Q) will be kept to a minimum.

The technique can be extended for applications both at audio and microwave. At audio, to cover the three-decade range from 20 to 20,000 Hz, reactive component values would be 0.63 H to 6.3 H for the variable inductor and 100 pF to 10 μF for the capacitor. The variable attenuator could be a standard audio 600-ohm symmetrical unit.

For microwave applications, the variable L and C might be a variable-length open or shorted line. A required condition in this case is that the line be capable of sufficient length variation to cover the circumference of the Smith chart over the desired frequency range. Also, the attenuator should be of a high-performance microwave type so that the exact frequency range is covered with minimal loss at the 0-dB setting. \square

COMPONENT VALUES FOR DESIGN EXAMPLE										
	L_1 (μH)	L_2 (μH)	C_1 (pF)	C_2 (pF)	L_2/L_1	C_2/C_1	f_1 (MHz)	f_2 (MHz)	f_3 (MHz)	f_4 (MHz)
Approximate Case	8.44	168.9	30	150	20.01	5	1.026	9.74	1.12	8.93
$L_{1,2}$ and C_2 Modified by 20%	6.75	202.7	30	180	30.03	6	0.84	10.99	0.91	10.2

REFERENCE

1. "Reference Data for Radio Engineers," fifth edition, Howard W. Sams & Co., New York, pp. 22-26.

How to choose a microwave counter

Choices can be made between the manual and automatic instruments, as well as between the heterodyne converter and transfer oscillator; decision criteria include frequency, cost, sensitivity, and speed

by Tony Schiavo and Bart Weitz, EIP Inc., Santa Clara, Calif.

□ Back in the good old days when the microwave engineer needed a good deal of dexterity and patience, the only way to measure the frequency of a microwave signal with quartz-crystal accuracy was to use a manual transfer oscillator. Then, the selection of a microwave counter was easy. He bought a manual transfer oscillator, or he did without.

Nowadays, however, both automatic and manual counters are available, and they can be either transfer oscillators or heterodyne converters. Thus, the user now has a freedom of choice for most measurements. And to go with it, he has the burden of learning enough about the four basic counter types to exercise that freedom intelligently.

Basically, all microwave counters work the same way: they accept unknown microwave-frequency inputs and translate them down to frequencies—typically below 250 MHz—that can be measured by direct gated counters. The differences between microwave counters are in the details of the ways to accomplish the translation.

The heterodyne technique

Manual heterodyne converters (Fig. 1) mix the unknown input frequency, F_x , with a harmonic of a known frequency, NF_c , so that one component of the mixer output, $F_x - NF_c$, is within the range of a direct counter. The known frequency, F_c , is usually generated by multiplying the output of a crystal-controlled reference oscillator to the maximum frequency that can be handled by the direct counter.

This frequency, in turn, is passed through a harmonic generator to produce a series of harmonics. A manually tuned cavity filter is then used to select the appropriate harmonic for the frequency to be measured. All the information needed to calculate F_x is now available: $F_x - NF_c$ can be read from the direct counter, N can be read from the dial of the manually tuned cavity, and F_c is a known constant.

This heterodyne technique can be automated by replacing the manually tuned cavity filter with an electronically tuned yttrium-iron-garnet (YIG) filter (Fig. 2). When a YIG-tuned filter is used, its frequency is swept, always starting from the bottom of the frequency band, as soon as an input signal is detected. The sweep is stopped when the frequency of the signal applied to the direct counter is within the direct counter's range. The direct-count frequency is then combined electronically

with the setting of the YIG-tuned filter to provide a calculation-free display of the unknown frequency.

The transfer oscillator

With the manual transfer oscillator (Fig. 3), an unknown harmonic of a tunable oscillator is mixed with the unknown frequency, and the mixer output is displayed on an oscilloscope. The oscillator is tuned manually until the display shows a zero beat, indicating that the unknown frequency is an integral multiple of the frequency of the fundamental oscillator.

The fundamental frequency of the oscillator is then measured and must then be multiplied by N to find the unknown frequency. Usually, the user knows the approximate frequency, and he can easily deduce what N must be; incorrect values would simply produce answers that are obviously wrong. If F_x and N are completely unknown, then several measurements and a

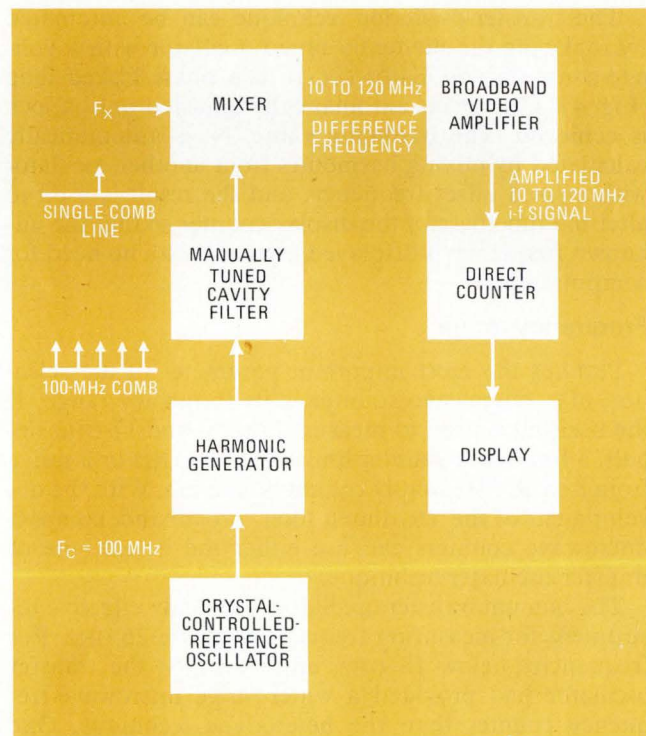

1. Heterodyne conversion. Tuned cavity selects single tooth from comb produced by harmonic generator. Direct counter counts difference between unknown frequency and harmonic.

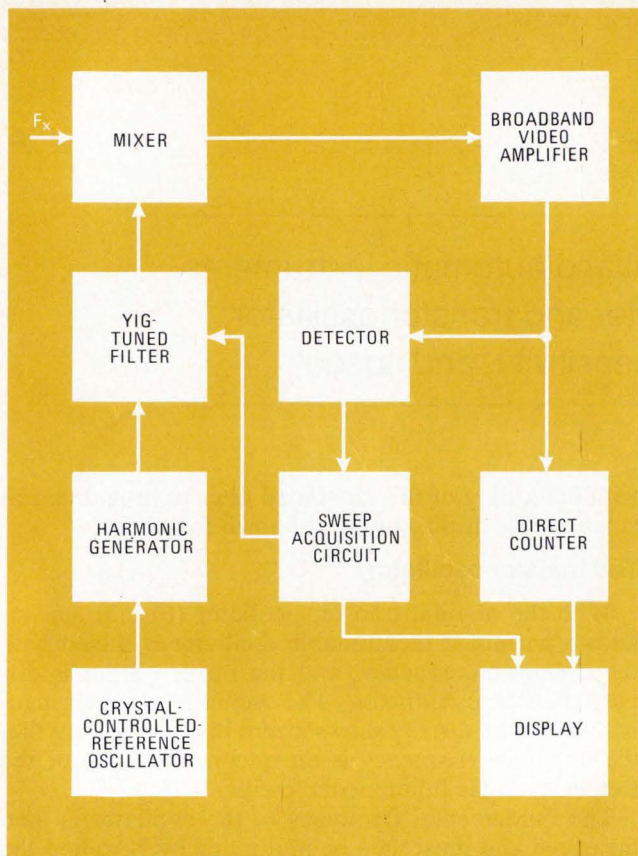

2. Automated heterodyne. Replacing the manually tuned cavity of the conventional heterodyne converter with an electronically controlled YIG-tuned filter not only allows the counter to be automated, but it cuts its size and broadens its bandwidth, as well.

simple calculation must be made to determine N .

The transfer-oscillator technique can be automated by replacing the manually tuned oscillator with a voltage-controlled oscillator (VCO) in a phase-locked loop (Fig. 4). The VCO is automatically adjusted until a lock is achieved. The harmonic value, N , is automatically calculated by mixing harmonics from another oscillator with a fixed offset frequency, and the result is used to alter the time base of the display counter so that the unknown frequency is displayed correctly with no need for computation.

Frequency range

Perhaps the most important parameter in the selection of a microwave counter is its frequency range. If the user has a need to measure both 6- and 17-GHz signals, a frequency counter limited to 12.4 GHz or a range from 8 to 18 GHz simply cannot do the job. With the development of the YIG-tuned filter, broadband, compact microwave counters can use either the heterodyne or transfer-oscillator technique.

The manual transfer oscillator is the only effective instrument for measuring frequencies above 26 GHz. For frequencies below 18 GHz, until recently, the transfer oscillator had provided a wider-range microwave-frequency counter than the heterodyne technique. One rack-mounted transfer oscillator, measuring 3½ by 17 inches, could be used to make measurements from 10 Hz to 18 GHz, while the manual heterodyne technique

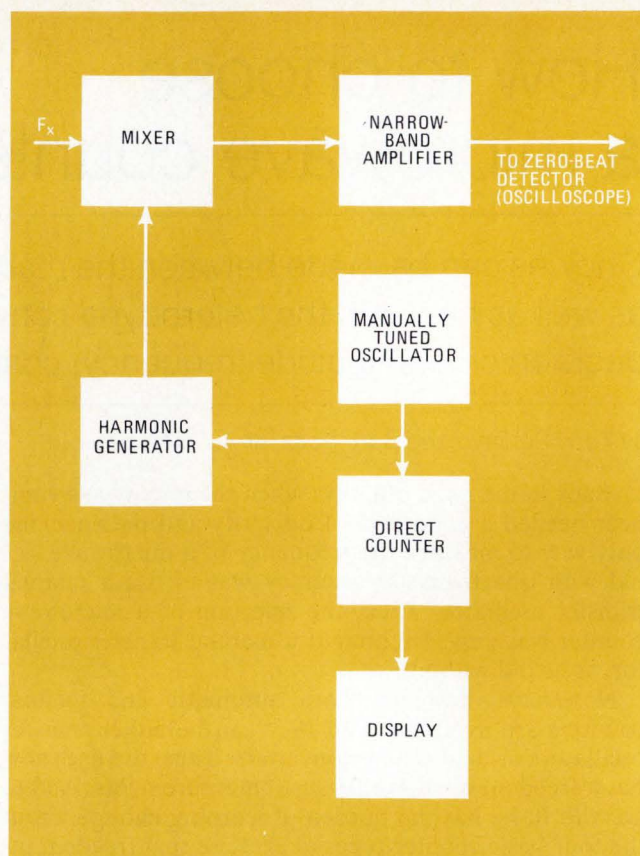

3. The rough and the smooth. The manually operated transfer oscillator is probably the most difficult type of microwave counter to use; however, it is the only one that can go above 26 GHz, and it is also the only available counter that can handle a pulsed rf signal.

required a unit 5¼ by 17 in. with three additional plug-ins to cover the same range.

The manual heterodyne technique is limited by the size and narrow tuning range of the cavities used to select the appropriate mixing frequency. The electronically tunable YIG filter offers two significant advantages over the mechanically tuned cavities: smaller size and wider frequency range. Since the resonant frequency of a YIG filter is independent of the YIG sphere size, very small resonators compatible with active microwave devices can be used. The result is an automatic heterodyne counter covering 10 Hz to 18 GHz in one 17-by-3.5-inch instrument. Although mechanically tuned cavities are limited to a two-octave tuning range, YIG filters can be tuned over a five-octave range without exhibiting high-level spurious modes.

Signal characteristics

After frequency range, probably the most important parameters to be considered in selecting a microwave counter are the various types of signals and signal levels that a counter can handle. A modulated carrier or a pulsed rf signal cannot be measured by a counter that will only accept cw signals. And a counter with a sensitivity of -10 dBm cannot be used to determine the frequency of a signal at -25 dBm.

All microwave counters can measure cw signals. Unfortunately, there's no such thing as a purely cw signal, so it is always important to know how much modu-

lation, or noise, a counter can handle. Further, there are many communications applications that necessitate the measurement of modulated signals. An example would be the monitoring of the carrier frequency of an fm signal. Essentially, this measurement is made with a frequency counter by averaging the positive and negative deviations over the gate time of the counter.

A counter's fm tolerance is specified in terms of the maximum peak deviation that can be tolerated at a given modulation rate. The variations in this tolerance can be quite large. At the low end, automatic transfer oscillators are very sensitive to fm; the phase-locked loop in these counters is usually limited to a bandwidth of less than 1 MHz, and thus a signal with a high modulation rate or wide deviation will break lock. In fact, some transfer-oscillator microwave counters are so susceptible to fm that measurements cannot be made on signals containing residual fm of the deviation and modulation rates found in inexpensive generators. The fm tolerance of a typical automatic transfer oscillator is illustrated in Fig. 5.

At the high end of the fm-tolerance spectrum, heterodyne converters require only that the peak-to-peak deviation of the input signal fall within the passband of the counter's video amplifier. Figure 6 illustrates the typical tolerance of a heterodyne microwave converter with comb spacing of 100 MHz from the harmonic generator. If the unknown frequency falls in the center of the video passband, the maximum deviation can be as high as 130 MHz (Fig. 6a).

The worst case occurs when the difference frequency into the broadband video amplifier is at the edge of the passband. Modern heterodyne-type counters employ specially designed video amplifiers that can tolerate maximum deviations of at least 10 MHz, even in the worst-case situation. In fact, if the modulation rate is about a kilohertz, or more, deviations of 20 MHz can be accommodated (Fig. 6b).

Some applications, such as monitoring radar signals, require the measurement of pulsed rf signals. The basic problem in making this measurement is acquiring the signal. Manual transfer oscillators now must be used to make this measurement. Simple heterodyne techniques cannot be used because there is no assurance that the signal will be present during the acquisition and gate times of the direct counter.

Sensitivity

The sensitivity specification of a microwave counter defines the minimum signal level that can be measured. Obviously, the better a counter's sensitivity, the less it must affect the system on which it is making a measurement.

Theoretically, transfer oscillators are about 20 dB more sensitive than heterodyne converters. Typically, the numbers are -30 dBm vs -10 dBm. The reason for this can be seen by comparing the block diagrams of Figs. 1 and 3. Assuming similar power levels from the reference-frequency source of the heterodyne converter and the tunable oscillator of the transfer oscillator, similar efficiencies for the harmonic generators and mixers, and that similar signal-to-noise ratios are required for the driving of the direct counter in the heterodyne unit

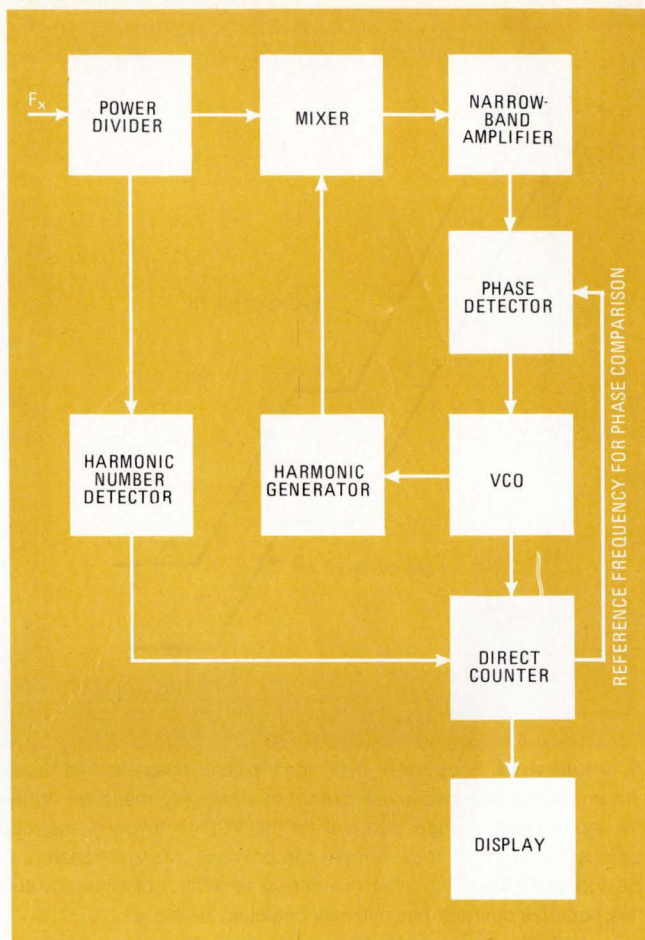

4. Automatic. A phase detector and a voltage-controlled oscillator (VCO) replace the human eye and hand in this automatic transfer oscillator. Since the human brain is not so easily replaced, fancy measurements, like pulsed rf, must still be done manually.

and for detecting the zero beat in the transfer-oscillator counter, there remains one important extra source of noise in the heterodyne counter—the broadband video amplifier. To overcome this extra noise, additional power must be supplied by the unknown signal, or, in other words, sensitivity suffers.

The sensitivity of a heterodyne converter can be improved by increasing the power output from the harmonic generator. This is generally accomplished by using a higher reference frequency for wider comb spacing. Even with the noise increase caused by the increased bandwidth of the video amplifier, the heterodyne technique makes possible a sensitivity of -20 dBm at 18 GHz.

Transfer oscillators, of course, can be designed for even greater sensitivities. However, sensitivities better than about -20 dBm can cause some unexpected measurement problems in automatic counters. In particular, they can pick up many signals in addition to the one of interest, which confuses the automatic-control circuitry and produces erroneous results. Sometimes this problem can be solved by incorporating an amplitude discriminator in the measuring circuit.

With an amplitude discriminator, only the highest-level signal is measured, provided that the difference in power level between the various frequencies is large (10

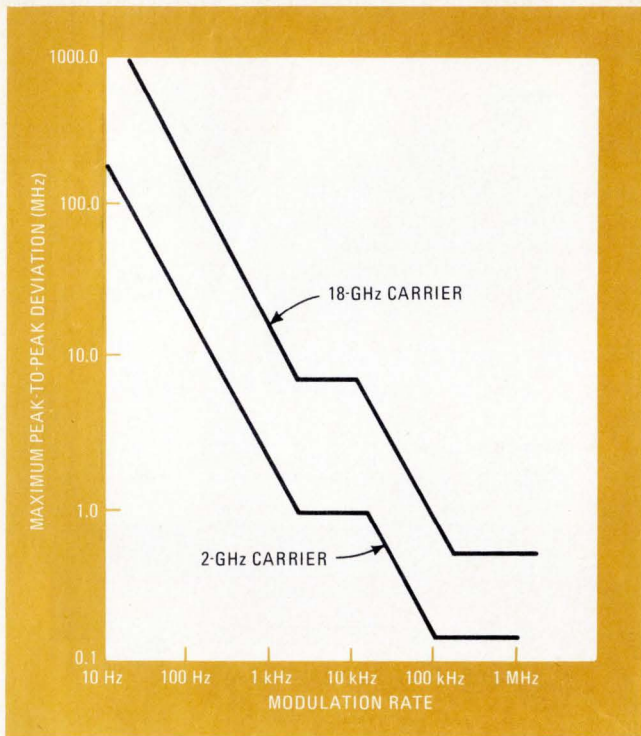

5. Intolerance. Because of their narrow-band phase-locked loops, automatic transfer oscillators cannot tolerate very much fm. When the input signal changes too fast for the VCO to follow it, the loop breaks lock, and no measurement can be made. Manual transfer oscillators still work in the presence of excessive fm, but accuracy suffers because operator has difficulty detecting zero-beat.

to 20 dB). Clearly, the user must have a good deal of *a priori* knowledge about the spectrum of the input signal before such an approach can be used with confidence.

Manual counters, of course, can handle composite signals with ease. They can be slowly tuned across their frequency bands to measure each of the frequencies individually. The manual approach, however, is time-consuming, and it requires the attention of a highly skilled technician or engineer. This is not a production-line technique.

Another solution to this problem is available with automatic heterodyne counters. In the automatic heterodyne counter, a YIG-tuned filter is swept from zero to the first frequency within the sensitivity specification of the counter. By selecting its start frequency in advance, the filter may be used as a built-in preselector. If the filter starts sweeping at 3.8 GHz, for example, the counter can measure the frequency of a 4.0-GHz signal, even in the presence of a stronger signal at, say, 3.4 GHz. The starting frequency for the YIG-tuned filter can be set by means of thumbwheel switches on the counter's front panel, or by external command in programmable counters.

Price vs convenience

While manually tuned microwave counters are cheaper, automatic microwave counters offer a significant advantage in ease of making the measurement and interpreting the display. With an automatic counter, measurements are made by simply connecting the unknown signal to the appropriate input. The correct fre-

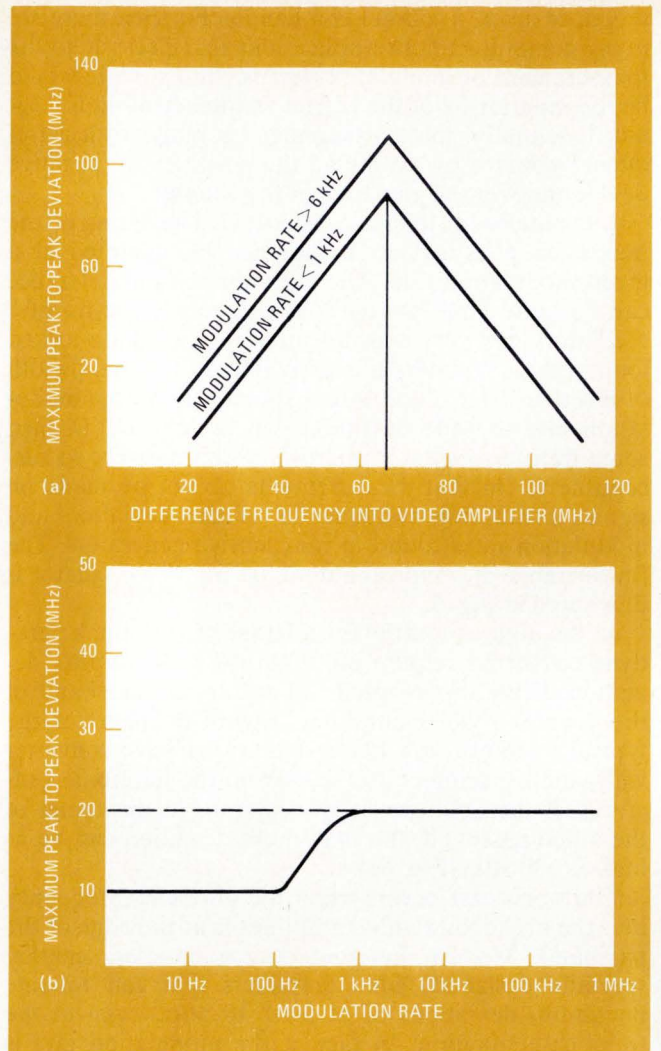

6. Tolerance. Heterodyne converter's tolerance for fm on input signal is greatest when difference frequency (see Fig. 1) is centered in pass-band of video amplifier (a). Even when frequency is at edge of pass-band, a deviation of at least 10 MHz can be accepted (b).

quency is displayed without additional interpretation.

To further minimize the need for display interpretation, the capability of automatically incorporating i-f offsets into the display is offered as an option in some counters. This option is useful when it is necessary to display the transmitted frequency, even though the receiver's local oscillator or transmitter's exciter is actually being monitored.

The manual microwave counter requires tuning of either the cavity in a heterodyne unit or the oscillator in a transfer-oscillator counter. In addition to the manual tuning, additional calculations are required to interpret the display. With a manual heterodyne counter, the mixing frequency as indicated on the cavity-tuning dial must be added to the display. The cavity must be tuned to the lowest mixing frequency that produces a response. Incorrect tuning can result in an incorrect reading. This problem is avoided with an automatic heterodyne counter, since the YIG filter is tuned from the lowest frequency to the highest frequency until a response is detected.

Manual transfer oscillators are even more difficult

SUMMARY OF COUNTER CHARACTERISTICS

	HETERODYNE CONVERTER		TRANSFER OSCILLATOR	
	Manual	Auto	Manual	Auto
Price	\$3,500	\$5,000	\$3,500	\$4,500—\$6,500
Measurement Ease	Moderate	Easiest	Difficult	Easiest
Frequency Range	8 GHz—18 GHz (one plug-in)	20 Hz—21 GHz	50 Hz—40 GHz	10 Hz—23 GHz
Sensitivity	-7 dBm	-3 dBm to -20 dBm	-4 dBm	-7 to -35 dBm
Fm Tolerance (at 100-kHz modulation rate)	10 to 130 MHz	10 to 130 MHz	0.2 to 0.8 MHz	0.2 to 0.8 MHz
Pulsed rf	No	No	Yes	No

and time-consuming than manual heterodyne units. First, the oscillator must be tuned for a zero beat and then the N number must be calculated and entered into the counter. If the wrong N is entered, the display is incorrect. The automatic transfer-oscillator counters completely automate this time-consuming process.

Waiting for the answer

The absence of external adjustments on automatic counters makes them ideal for incorporation into automatic measurement systems. When used in such systems, measurement speed suddenly becomes a parameter of great importance. The throughput of a high-volume production-test facility is critically dependent upon the speeds of each of its components. Thus, a counter's measurement speed may well become the most important specification to the man setting up an automatic test facility.

When calculating measurement speed, there are two time periods of interest: acquisition time and reading time. The acquisition time is the time required for the counter to acquire or settle upon the unknown frequency. In the transfer oscillator, this is the time necessary to obtain phase lock between the unknown signal and a harmonic of the local oscillator.

In the heterodyne technique, it is the time necessary to select the proper mixing frequency to heterodyne the unknown signal into the video passband of the amplifier. The acquisition time of an automatic transfer oscillator is generally 150 ms, independent of the unknown frequency. The acquisition time of an automatic heterodyne counter is a function of the unknown frequency—25 ms/GHz of the sweep required.

It should be noted that in making a series of measurements, it is not always necessary to acquire each signal separately. For an automatic transfer oscillator, a signal must be reacquired only if it differs by more than about 2% from the previously acquired signal. For an automatic heterodyne converter, reacquisition is required approximately every 100 megahertz.

The start frequency for the sweep in an automatic heterodyne counter can be remotely programed to min-

imize acquisition time when the frequency range is known. Similarly, automatic transfer-oscillator acquisition times can be improved by preselecting the operating range. Naturally, the automatic techniques offer substantially faster acquisition times than the manual approaches and thus are oriented toward systems use.

The reading time includes the time needed to reset the digital logic of the direct counter, plus the gate time. The gate time is a function of the converter technique, heterodyne or transfer oscillator, and the resolution required. The reset time is pretty much the same for all instruments—about 25 ms.

For a heterodyne converter, the gate time is the inverse of the required resolution. That is, a resolution of 0.1 Hz requires a gate time of 10 seconds, while a resolution of 1 kHz requires a gate time of only 1 ms.

For a transfer oscillator, the gate time is related not only to the required resolution, but to the frequency being measured, as well. To be more specific, the gate time for a transfer oscillator is N times longer than the gate time for a heterodyne converter, where $N = F_x/F_{VCO}$ is the harmonic number. Since the frequency of the VCO is typically in the range of 100 to 150 MHz, N can become quite large. For an X-band signal, N can easily exceed 100.

In short, heterodyne counters have a significant speed advantage when many closely spaced, high-resolution measurements must be made—particularly when they must be made on very high frequencies. The automatic transfer oscillator, on the other hand, wins for single, widely spaced, low-resolution measurements.

The various parameters discussed above are summarized in the table, which reflects the characteristics of commercially available instruments—not what is theoretically possible. For example, the table shows that automatic transfer oscillators are much more sensitive than manual transfer oscillators. This does not mean that manual units cannot be made as good as automatic ones; it simply reflects the fact that existing manual transfer oscillators are of older design than the automatic units, and they have not benefited from technological advances made since they were designed. □

An offshore plant will reduce your electronics manufacturing costs.

On paper.

The competitive challenge of imports hasn't hit any market harder than electronics. An offshore plant with low labor rates seemed to offer a convincing way to regain the profitability edge. Until the plant was built and local realities set in. Restrictive labor regulations, stretched logistics, and unfamiliar conditions all tended to eat up those paper profits. It didn't really take a palace revolution to put you in the red.

Universal Instruments Corporation has quietly pioneered a different approach to help you combat the stacked deck of import price competition in electronics. We reasoned that if we could take the handwork out of electronic assembly, you could avoid the pitfalls of chasing cheap labor around the world to keep your manufacturing costs down.

Now, computer-controlled automated assembly systems developed and refined by Universal over the past 15 years are providing a better answer to imports—in markets as diverse as color television and seat belt interlock systems.

For example: a flexible complex of Universal sequencers and component insertion machines controlled by worker and supervisory computers adjusts rapidly to meet changes in production schedules at a

major U.S. electronics manufacturer. To keep their plant competitive by turning out 85,000 circuit modules—enough for more than 10,000 color TV sets—per day.

For the new generation of automotive electronics, the Universal In-Line Assembly System can put together circuit boards for digital clocks, anti-skid controls, fuel injection and other devices faster and more economically than any other system. It can assemble approximately 1,260,000 boards per 10-month seven-hour single-shift production year. A production advance that enables electronics and auto makers to meet this high volume demand—profitably—at home.

Then there's the flexible new "Quadraser" that handles circuit boards automatically, computer-controlled wire termination systems, and the "Multisert" system that inserts up to ten components at once. Plus emerging production technology developments from Universal to help make your present domestic production at least as cost-effective as past offshore production. Even in 1985, when U.S. manufacturers will need over one billion circuit boards.

Because we know there's no way except better technology to keep all of us in the electronics business.

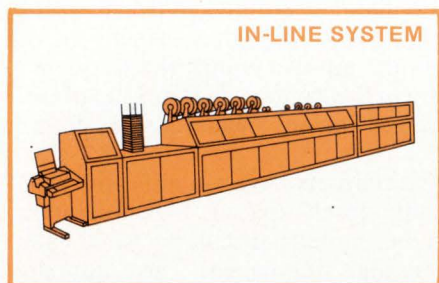

IN-LINE SYSTEM

The most cost-effective system available for high volume circuit board production.

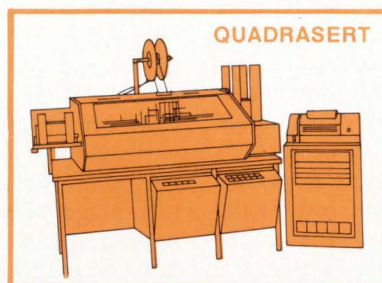

QUADRASERT

Combining automated board handling with moving table insertion for added flexibility in high volume circuit board production.

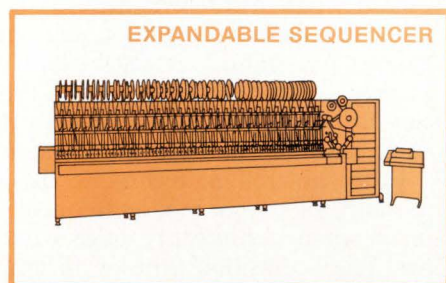

EXPANDABLE SEQUENCER

Add-on flexibility from 20 to 95 stations permitting growth without production obsolescence in your component sequencing operation.

Write or call us today for complete technical literature and production specifications on these and other Universal systems—including a wide line of insertion machines, sequencers, and wire wrap systems—as well as information on our extensive contract facilities for electronic assembly.

 **Universal** INSTRUMENTS CORPORATION
P.O. Box 825 / Binghamton, New York 13902
Tel: 607-772-7522 • Twx: 510-252-1990

U.I.C. Sales and Service Offices in California: Santa Ana, San Francisco; Colorado: Denver; Florida: St. Petersburg; Illinois: Rolling Meadows; New Hampshire: Manchester; New York: Binghamton; North Carolina: Raleigh; Ohio: Granville; Texas: Dallas. Also offices in Bombay, Copenhagen, Frankfurt, London, Milan, Montreal, Paris, Sidney, Tel Aviv, Tokyo, and Toronto.

Bipolar transistor pair simulates unijunction

by N.A. Shyne
Montana State University, Bozeman, Mont.

The negative-resistance characteristic of a programmable unijunction transistor (PUT) can be simulated by interconnecting two discrete bipolar transistors. This equivalent PUT can not only switch faster than a conventional unijunction transistor, but it also offers better temperature stability. And parts cost can be as low as \$1.

The four-layer structure of a PUT is approximated by arranging complementary transistors Q_1 and Q_2 as shown in the figure. Applied bias voltage V tends to place the quiescent operating point of both transistors in their forward active regions. Current I is given by:

$$I = (I_{C01} - I_{C02}) / (1 - \alpha_{F1} - \alpha_{F2})$$

where α_{F1} and α_{F2} are the common-base short-circuit forward current gains of transistors Q_1 and Q_2 , respectively; and I_{C01} and I_{C02} are the respective reverse saturation currents of the base-collector junctions of Q_1 and Q_2 . (Current I_{C01} is negative.)

In general, the numerator of this equation is not zero. As the sum of α_{F1} and α_{F2} approaches unity, current I increases without limit. The feedback between the two transistors is positive, since the collector current of Q_1 is the base current of Q_2 , and vice versa. The condition for regenerative feedback, then, is:

$$\alpha_{F1} + \alpha_{F2} = 1$$

OR:

$$\beta_{F1} \beta_{F2} = 1$$

where β_{F1} and β_{F2} are the common-emitter short-circuit forward current gains of transistors Q_1 and Q_2 , respectively.

Resistors R_1 and R_2 permit the value of the equivalent PUT's intrinsic standoff ratio, η , to be varied. Let base B1 be the voltage reference point (ground), while base B2 is at a positive potential, V_{BB} . With the PUT's emitter (E) terminal open, the voltage at point B can then be expressed as:

$$V_B = [R_1 / (R_1 + R_2)] V_{BB} = \eta V_{BB}$$

so that:

$$\eta = R_1 / (R_1 + R_2)$$

If emitter voltage V_E is now increased to:

$$V_E = \eta V_{BB} + V_D$$

where V_D is the base-emitter voltage of transistor Q_1 , both transistors will become saturated, and the PUT circuit will switch. When switching occurs, resistor R_1 is shorted out by transistor Q_2 , and:

$$V_{Emin} = V_D + V_{CE2sat}$$

where V_{CE2sat} is the collector-emitter saturation voltage of transistor Q_2 . This value of V_{Emin} is usually lower than that of a conventional unijunction transistor. (Generally, it is best to use silicon transistors to keep leakage currents low so that the sum of α_{F1} and α_{F2} is less than unity with the PUT's emitter open.)

The switching speed of this equivalent PUT is limited only by the maximum operating frequency of the bipolar transistors used for Q_1 and Q_2 . Usually, the switching speed is considerably faster than that of a conventional unijunction transistor.

If silicon transistors are used, the value of switching voltage V_D drifts only 3 millivolts/ $^{\circ}$ C. And with the proper selection of resistors R_1 and R_2 , intrinsic stand-

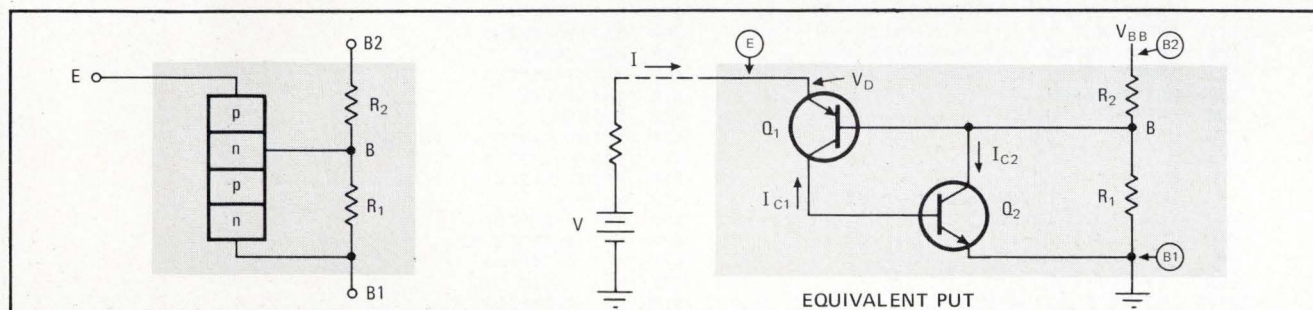

PERFORMANCE COMPARISON

PARAMETER	CONDITION	EQUIVALENT PUT*	TYPICAL UJT**
R_{BB} , interbase resistance	$V_{BB} = 3 \text{ V}, I_E = 0$	9.4 k Ω	6.2 - 9.1 k Ω
η , intrinsic standoff ratio	$V_{BB} = 10 \text{ V}$	0.5	0.51 - 0.62
I_p , peak point current	$V_{BB} = 25 \text{ V}$	-160 nA	12 μ A max
I_{EO} , emitter reverse current	25 $^{\circ}$ C	1 nA	2 μ A max
I_v , valley current	$V_{BB} = 10 \text{ V}$	-200 μ A	8 mA

* $Q_1 = 2N4126, Q_2 = 2N4124, R_1 = R_2 = 4.7 \text{ k}\Omega$

** UJT = 2N490A

Simulating a unijunction transistor. An equivalent programmable unijunction transistor (PUT) can be realized by wiring complementary bipolar transistors as shown. The resulting equivalent PUT offers faster switching and less temperature drift than an ordinary unijunction transistor (UJT). The table compares the major characteristics of the equivalent circuit to a typical UJT.

off ratio η can be made essentially independent of changing temperature.

The table compares the performance of the equivalent PUT to the performance of a typical unijunction

transistor, a type 2N490A device. For the comparison, $R_1 = R_2 = 4.7$ kilohms and $\xi = 0.5$. A complementary (to the one shown) equivalent PUT can be made by just interchanging the positions of transistors Q_1 and Q_2 . □

Program analyzes all-resistive dc circuits

by Mark Jong
Wichita State University, Wichita, Kansas

Networks that are strictly resistive can be analyzed easily and quickly for dc conditions with a brief but effective computer program written in Basic. The circuit to be analyzed can also contain active devices, provided those devices can be represented by only resistive elements and voltage-dependent sources.

The standard circuit branch allowed by the program is shown in Fig. 1, along with the program listing. Nodes may be numbered in any order with consecutive integers beginning with zero. (The program always assumes that node 0 is the reference node.) Branches may also be numbered in any order with consecutive integers, but this set of numbers must begin with the number one.

The program first asks to know the number of nodes minus one, and then it requests the number of branches.

1. Dc circuit analysis. Computer program, which is written in Basic, is useful for a speedy dc analysis of small resistive networks. The definitions for a standard circuit branch and the program listing itself are given here. Dependent sources must be voltage-controlled.

(A question mark is typed after each request.) The user responds by typing in the data requested each time and pressing the RETURN key on his terminal.

After this preliminary input data is obtained, the program asks for the branch data by typing a question mark each time for each branch. In response, the user types in the data for each branch in a specific order and

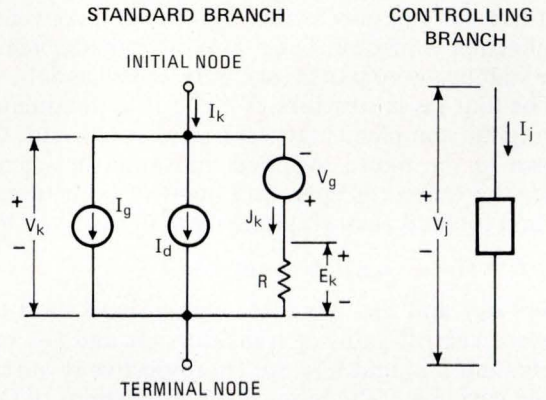

V_k, V_j = BRANCH VOLTAGES
 I_k, I_j = BRANCH CURRENTS
 E_k = ELEMENT VOLTAGE
 J_k = ELEMENT CURRENT
 V_g, I_g = INDEPENDENT SOURCES
 $I_d = g_m \cdot V_j$ (VOLTAGE-CONTROLLED CURRENT SOURCE)

```

100 DIM A(7,15),Y(15,15),E(15),I(15),
    J(15),V(15),S(15),W(15,7),U(15,7)
110 PRINT "NUMBER OF NODES - 1 = ";
111 INPUT N
120 PRINT "NUMBER OF BRANCHES = ";
121 INPUT B
130 MAT A=ZER(N,B)
140 MAT Y=ZER(B,B)
150 MAT E=ZER(B)
160 MAT I=ZER(B)
170 FOR K=1 TO B
180 INPUT B1,F1,T1,R,E(B1),I(B1),Y1,C1
190 IF F1=0 THEN 210
200 LET A(F1,B1)=1
210 IF T1=0 THEN 230
220 LET A(T1,B1)=-1
230 LET Y(B1,B1)=1/R
240 IF C1=0 THEN 260
250 LET Y(B1,C1)=Y1
260 NEXT K
270 MAT S=ZER(B)
275 MAT J=ZER(B)
280 FOR K=1 TO B
281 LET S(K)=Y(K,K)*E(K)
282 NEXT K
290 MAT S=I+S
295 MAT S=J-S
300 MAT W=ZER(B,N)
310 MAT W=TRN(A)
320 MAT U=ZER(B,N)
330 MAT U=Y*W
340 MAT W=ZER(N,N)
350 MAT W=A*U
360 MAT U=ZER(N,N)
370 MAT U=INV(W)
380 MAT V=ZER(N)
390 MAT V=A*S
400 MAT J=ZER(N)
410 MAT J=U*V
420 PRINT
430 PRINT "NODE", " VOLTAGE"
440 FOR K=1 TO N
450 PRINT K,J(K)
460 NEXT K
470 MAT V=ZER(B)
480 MAT W=ZER(B,N)
490 MAT W=TRN(A)
500 MAT V=W*J
510 MAT J=ZER(B)
520 MAT J=Y*V
530 MAT J=J-S
540 PRINT
550 PRINT "BRANCH", " VOLTAGE", " CURRENT", " POWER"
560 FOR K=1 TO B
570 PRINT K,V(K),J(K),V(K)*J(K)
580 NEXT K
590 MAT V=V+E
600 PRINT
610 PRINT "ELEMENT", " VOLTAGE", " CURRENT", " POWER"
620 FOR K=1 TO B
630 LET J(K)=Y(K,K)*V(K)
640 PRINT K,V(K),J(K),V(K)*J(K)
650 NEXT K
660 END

```

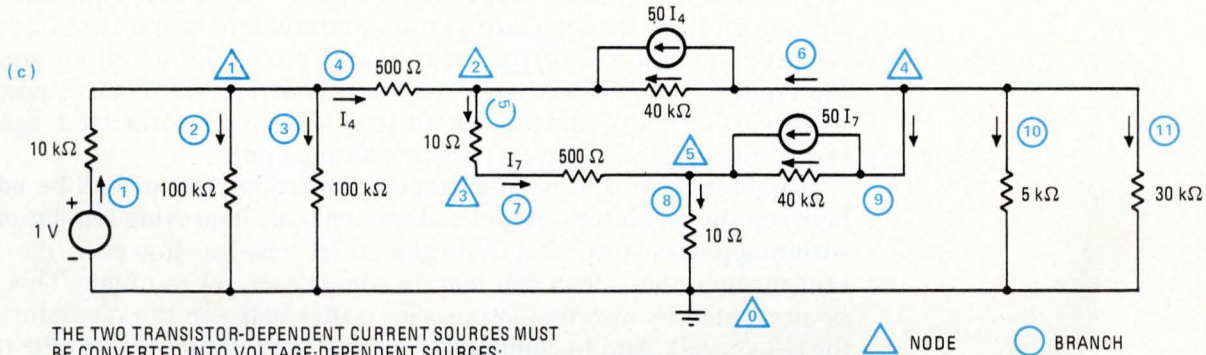
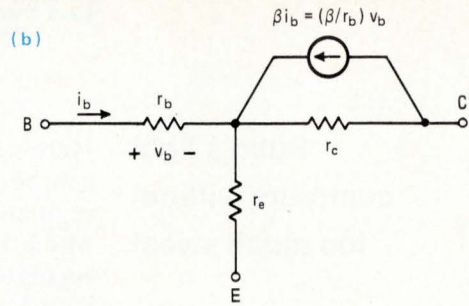
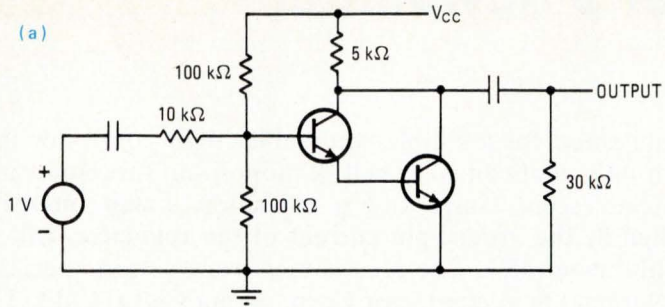
THE TWO TRANSISTOR-DEPENDENT CURRENT SOURCES MUST BE CONVERTED INTO VOLTAGE-DEPENDENT SOURCES:
 $50 I_4 \rightarrow 50 (V_4/500) = 0.1 V_4$.
 AND $50 I_7 \rightarrow 0.1 V_7$

```
(d)
READY
RUN
NUMBER OF NODES - 1 =75
NUMBER OF BRANCHES =711
?1,0,1,10000,0,0,0,0
?2,1,0,10000,0,0,0,0
?3,1,0,10000,0,0,0,0
?4,1,2,500,0,0,0,0
?5,2,3,10,0,0,0,0
?6,4,2,40000,0,0,0,1,4
?7,3,5,500,0,0,0,0
?8,5,0,10,0,0,0,0
?9,4,5,40000,0,0,0,1,7
?10,4,0,5000,0,0,0,0
?11,4,0,30000,0,0,0,0
```

NODE	VOLTAGE	BRANCH	VOLTAGE	CURRENT	POWER	ELEMENT	VOLTAGE	CURRENT	POWER
1	.428572	1	-.428572	5.71428E-05	-2.44898E-05	1	.571428	5.71428E-05	3.26530E-05
2	.404286	2	.428572	4.28572E-06	1.83674E-06	2	.428572	4.28572E-06	1.83674E-06
3	.400121	3	.428572	4.28572E-06	1.83674E-06	3	.428572	4.28572E-06	1.83674E-06
4	-.82.0203	4	2.42857E-02	4.85713E-05	1.17959E-06	4	2.42857E-02	4.85713E-05	1.17959E-06
5	.191866	5	4.16505E-03	4.16505E-04	1.73477E-06	5	4.16505E-03	4.16505E-04	1.73477E-06
		6	-.82.4246	-2.06062E-03	1.69845	6	-.82.4246	-2.06062E-03	1.69845
		7	.288255	4.16509E-04	8.67399E-05	7	.288255	4.16509E-04	8.67399E-05
		8	.191866	1.91866E-02	3.68127E-03	8	.191866	1.91866E-02	3.68127E-03
		9	-.82.2122	-1.87701E-02	-1.54314	9	-.82.2122	-1.87701E-02	-1.54314
		10	-.82.0203	-1.64041E-02	1.34547	10	-.82.0203	-1.64041E-02	1.34547
		11	-.82.0203	-2.73401E-03	.224245	11	-.82.0203	-2.73401E-03	.224245

on the same line. He gives the branch number, the initial node number, the terminal node number, the resistance value, the value of the independent voltage source, the value of the independent current source, the transconductance of the dependent current source, and the number of the branch that is controlling the dependent current source, finally pressing the RETURN key.

The polarity signs allotted to the voltage and current sources must agree with the sign conventions defined by the standard branch of Fig. 1. The various data inputs must be separated by commas.

Once the program has all of the input data, it will compute the circuit's output node voltages, as well as all the branch and element voltages, currents, and power. The element of a branch is the resistance of that branch. When there is no current source associated with a branch, the branch current is the same as the element current. And when a branch does not have a voltage source, branch and element voltages are the same.

Figure 2 shows an example analysis of a two-transistor amplifier (Fig. 2a). The simple T-model equivalent circuit (Fig. 2b) is used to represent each transistor. In the complete amplifier equivalent circuit (Fig. 2c), the node numbers are enclosed by triangles, and the branch numbers are encircled. The program printout (Fig. 2d) conveniently tabulates the input data, the output node voltages, the branch data, and then the element data.

On a 16-bit minicomputer with an 8,000-word memory, the program can handle a circuit having up to seven nodes and 15 branches. If a machine with more storage capacity is used, the dimensions of the arrays set up by statement 100 in the program listing can be increased to accommodate larger circuits. □

Engineer's notebook is a regular feature in Electronics. We invite readers to submit original design shortcuts, calculation aids, measurement and test techniques, and other ideas for saving engineering time or cost. We'll pay \$50 for each item published.

Build a light controller without too much sweat

Here's a neat suggestion for a simple, yet stable, light controller that can be built with only a silicon solar cell, a monolithic three-terminal regulator, an incandescent lamp, and a capacitor. **Lamp intensity, which is controlled by the ground-pin current of the regulator, will be regulated to within about 15%.** The idea comes from design specialist Carl Nelson of National Semiconductor Corp., Santa Clara, Calif. The lamp is connected from the regulator's output terminal to ground, the silicon cell from the regulator's ground terminal to ground, and a large (about 25-microfarad) capacitor is placed across the lamp. Of course, the regulator should be able to produce a current that is large enough to drive the lamp, and its output should be fully protected against shorts, overloads, or turn-on surges from the lamp.

If tighter control of lamp current is needed, a resistor can be added between the regulator's output and ground pins, improving regulation to within approximately $\pm 2\%$. With the added resistor, however, the current through the silicon cell may in some cases get too high. This can be prevented by inserting a transistor buffer between the regulator and the silicon cell. **And to compensate for any temperature drift in the transistor's base-emitter voltage, a junction diode can also be added.**

How to get the measure of picosecond delays

Measuring picosecond propagation delays in today's high-speed logic circuitry can't be done with the old single-shot measurements. With those, the resolution unfortunately is determined strictly by the system clock rate—a 100-megahertz clock gives a resolution of 10 nanoseconds, a 500-MHz clock gives 2 ns, and that's about it. The trick is to **use a test rig that gives a repetitive signal, so that averaging techniques can improve resolution by several orders of magnitude.**

Resolution improves as the square root of N, where N is the number of measurements being averaged, provided that the counter time base and the interval being measured are not harmonically related. One way to ensure that they're not is to jitter the clock slightly by modulating it with a band-limited Gaussian noise signal. **The result can be resolutions on the order of 10 to 100 picoseconds.**

Two things to be glad about: hybrid high-Q filters . . .

Engineers accustomed to designing their own fixed-frequency, high-Q filters and amplifiers should check out some recent hybrid-IC developments, which will let them buy circuits that till now could only be hand-built. For example, **high-Q filters containing as many as 50 chips per package and providing 500-decibel/octave rolloffs at audio frequencies** are now available from several manufacturers. Multilayer hybrids, combining passive and IC chips, now also come in DIPs.

. . . and help with metrication

Now that the U.S. is seriously considering a switch to the metric system and in all probability will begin a slow conversion in the near future, information on how to implement the conversion can be useful. One source is a Metrication Information Center, which is offering a **seven-volume package of publications on the metric system, organizations that establish metric standards, how to soften the trauma of metrication, etc.** Write: Metric Information Center, Society of Manufacturing Engineers, 20501 Ford Road, Dearborn, Mich. 48128.



HP's New Fast FORTRAN Processor: This Tiger Is No Pig.

It's a firmware package that
runs FORTRAN IV programs
up to 28.8 times faster.

And it's available only on
Hewlett-Packard's microprogrammable
2100 minicomputer.

To buy one,
contact your local HP field engineer.

Ask him to run
your FORTRAN IV benchmark.

Or write

HEWLETT  PACKARD

Sales and service from 172 offices in 65 countries.
1501 Page Mill Road, Palo Alto, California 94304



We set the industry standard
the day we started making computers.

When we were designing our first computer, we decided to put as big a subsystem as we could on each PC board.

Within three years, the accepted way to build small computers was the Data General way.

And when we were working on our second computer, we made it completely compatible with our first. So all our software and peripherals could run on both computers. And the interfacing would be just as easy.

And we held on to that idea. The nine computers we've made since then are fully compatible, too. For the same reasons.

In other words, we invented what's now known as a "family" of small computers.

We're at it again with our Nova 2. Only this time we're helping you get your products out into the marketplace faster.

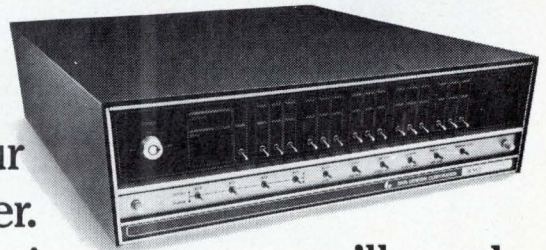

We've given the Nova 2 the operating systems you'll need to develop your software and run your hardware. So you won't have to come up with your own.

We're offering low-cost 16K memory so your programmers can work in high-level languages. And write software faster.

We have the general purpose interfaces you'll need to make that job go faster.

And we have the support organization you can call anytime you need help.

Making computers easier for you to work with isn't exactly standard in the industry.

Someday it may be.

At Data General, that day is now.

DataGeneral

The computer company you can understand.

• Data General Corporation Southboro, Massachusetts 01772. (617) 485-9100.
Datagen of Canada Ltd., Hull, Quebec (819) 770-2030/Data General Europe, Paris, France 504-23-44.

2001
 2000
 \$320

The big difference between these high-frequency sweepers is \$320.

The little differences are on the front panel (a start/stop mode of operation and a tape drive readout). Some people think they add up to \$320. For them, we built the 2001.

And for those people who don't require these features, we built the 2000. The 2000 is the only sweeper under \$1400 to offer frequency coverage of 1 MHz to 1.4 GHz, solid-state design, calibrated RF output from -80 to +10 dBm, P.I.N. diode leveling and a crystal-controlled marker system.

In addition, its frequency, bandwidth, and output level are programmable, making it ideal for production test and systems use as well as in the design laboratory. If you're still not sure which sweeper we built for you, send for more information. Just circle the reader service number or give us a call.

WAVETEK®

INDIANA INCORPORATED
 P. O. Box 190, 66 North First Ave., Beech Grove, Indiana 46107
 Tel. (317) 783-3221 TWX 810-341-3226

Model 2000
 \$1375



Circle 120 on reader service card

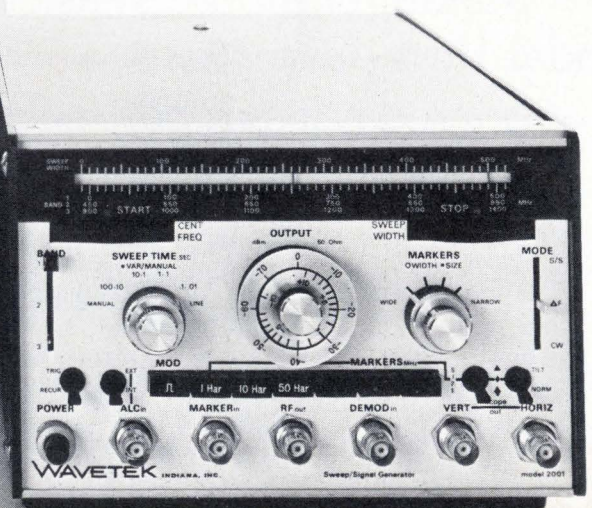

Model 2001
 \$1695

New products

Counter measures to 500 MHz directly

Reciprocal instrument maintains high resolution at all frequencies, handles pulsed rf signals, is suitable for automatic test systems

by Michael J. Riezenman, Instrumentation Editor

As successor to the venerable 5245 family of frequency counters, Hewlett-Packard's 5345A electronic counter has been designed to take on the time and frequency measurement problems of today's fast logic circuitry, sophisticated radars, and data communications systems. It is capable of such feats as 2-nano-second resolution (2-picosecond for repetitive signals), 9-digit frequency measurements (for a 1-second gate time) regardless of frequency, and carrier-frequency measurements on rf pulses as narrow as 50 ns. Essentially, though, the 5345A is a general-purpose laboratory instrument with a 500-megahertz basic clock rate, switchable input impedances of 50 ohms and 1 megohm, and a modest price tag of \$3,450.

Reciprocal. The 5345A is a reciprocal counter—that is, to measure frequency, the machine actually measures period and inverts the

number thus obtained to get the desired frequency reading. The inversion is performed by a calculator-type digital processor. Period measurements are made by selecting an approximate gate time and having the input signal control the precise instants at which the counter gate is opened and closed. While the gate is open, the instrument counts its own internal clock; thus, resolution is determined only by the gate time and the system clock frequency.

In the case of the 5345A, the system clock frequency is 500 MHz. Thus, a 1-second gate time always results in 9-digit resolution. Perhaps a better way to appreciate the significance of these numbers is to consider the problem of a manufacturer of, say, quartz-crystal watches who must make production-line frequency measurements on 32-kilohertz crystals. To get the 7-digit resolution required in such an appli-

cation takes about 10 milliseconds with the 5345A. A conventional counter would need 100 seconds.

Because the counter contains a small digital processor, it should prove capable of handling a wide variety of as-yet-uninvented plug-in modules, in addition to all of the existing plug-ins for the 5245 family. Fully a third of the mainframe's volume and a considerable fraction of its power-supply capacity have been reserved for these modules. So far, two plug-ins have been specially designed for the 5345A: an automatic heterodyne converter for microwave measurements up to 4 gigahertz, and an auxiliary full-bandwidth input channel to add to the two on the mainframe. This third channel is intended for digital applications such as counting pulses between two events.

Having a processor in the counter has another advantage: it makes it

Unique measurement capability. The 5345A counter is shown being used, with a microwave converter plugged in, to measure the carrier frequency of the pulsed rf signal, shown on the scope. The converter is the first heterodyne type that can handle pulsed rf signals.

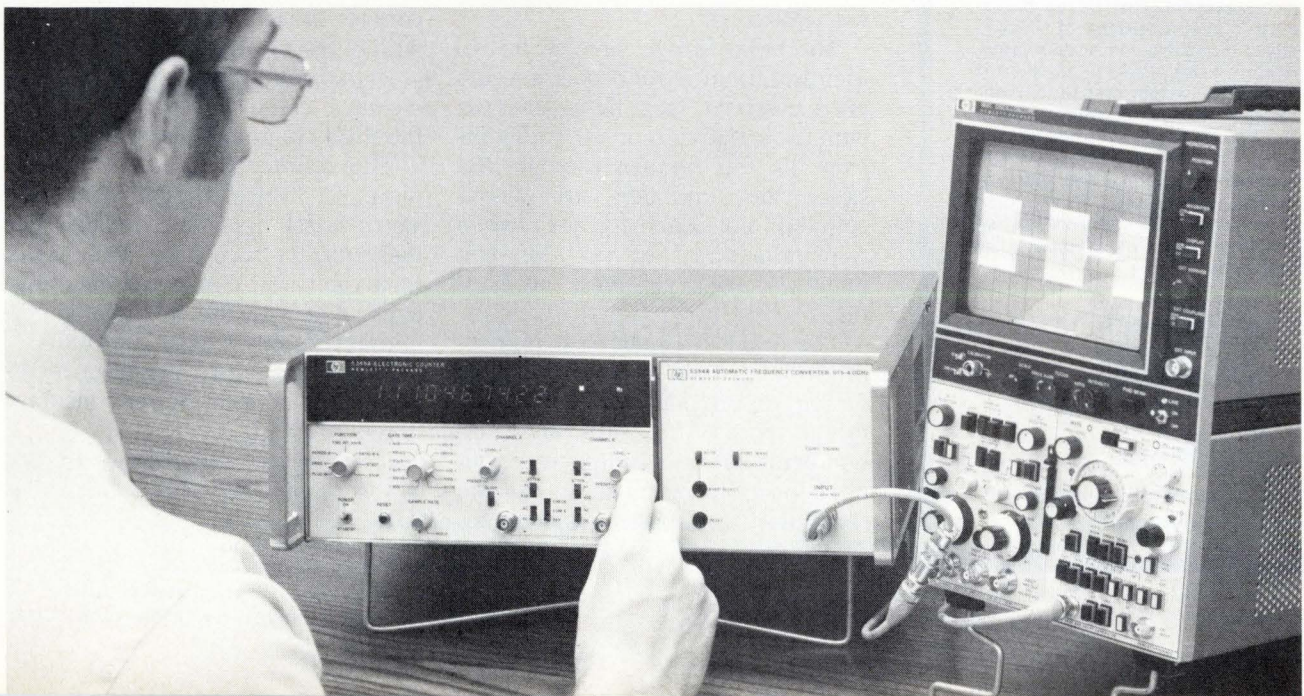

The State of the Art

THE X-Y EFFECT

X.

Recently, we received an assignment from customer X to work with him in the development of his new product. Our monolithic crystal filter was to be a key part of his product's system. We started with him on his project at earliest breadboard and carried through over a two year span to final manufacturing. We worked in close collaboration with X, tailoring filter and product to one another. The result is a product unique in its field, which, based on performance and cost, has gained outstanding market acceptance. Our custom monolithics helped.

Y.

Not every new product requires two years to develop. Customer Y saw an immediate market for a new application of radio control. But his existing control receiver would be subject to interference in the new environment. Time was short. We were consulted, and recommended a standard model filter that provided the necessary i-f selectivity. Prototypes were shipped from stock. Later we were able to speed his first production run by supplying several hundred of the same standard model filter in less than four weeks. In addition to saving time, customer Y was able to take advantage of standard model engineering and pricing for his requirement, which eventually totaled a very modest, but highly successful, 1500 units for Y.

And success is the name of the game. Whether it's a brand-new project or a fast reread of an old standby we've got the filters to make your design successful. First there's the industry's largest selection of standard model monolithic and tandem monolithic crystal filters. And when it comes to custom modes, our unmatched experience assures you of the sound engineering advice you need. Last but not least, our unequalled capacity gets you your production units on time. We've proved it for X and Y and we'd like to add you to our alphabet. Drop us a line or call us.



Piezo Technology Inc.

2400 Diversified Way
Orlando, Florida 32804
305-425-1574

The Standard in monolithic
crystal filters.

New products

easy to improve resolution by averaging measurements on repetitive signals. The improvement obtainable by this means is proportional to the square root of the number of measurements being averaged.

Actually, to be certain that the averaging technique will produce valid results, it is necessary to ensure that the quantity being measured has no harmonic relationship to the system clock rate. The 5345A guarantees that this condition is met by randomly modulating the clock frequency when the instrument is used in its averaging mode.

Rf pulses. For most electronic counters, the minimum time that the gate can be open is about a microsecond. For the 5345A it is about 50 ns. This extremely narrow gate time is made possible by the use of emitter-emitter logic circuitry capable of operating at speeds in excess of 650 MHz. In addition to providing unprecedented resolution in single-shot time-interval measurements, these super-fast gates make it possible to "get inside" extremely narrow pulses of rf to measure carrier frequencies. It is even possible to measure the frequency at more than one point within a pulse to study the characteristics of such signals as those produced by pulse-compression radars.

This ability to measure pulsed rf signals is not lost when the 4-GHZ plug-in is used. The microwave unit, which spans a range of 15 MHz to 4 GHz, is the first automatic heterodyne converter capable of working with pulsed rf.

The basic 5345A comes with two identical input amplifiers. Each covers a passband from dc to 500 MHz with a sensitivity of 10 millivolts over the full frequency range. Because the amplifiers are direct-coupled, no problems arise when nonsymmetrical or very-low-frequency waveforms must be handled.

The input attenuators in front of the input amplifiers use a stripline design to provide a good 50-ohm match across the full operating bandwidth. By switching out the 50-ohm resistive termination to the stripline, a front-panel switch makes

it easy to change the input impedance to 1 megohm in parallel with less than 30 picofarads.

Because the counter's input impedance can be switched between the two common values found in oscilloscopes, the instrument can be used with standard oscilloscope probes. Both high-impedance voltage-divider probes and 50-ohm terminating probes can be accommodated.

In addition to being useful as a bench-top instrument, the 5345A is a fully programable counter and is suited for use in automatic measurement systems. For \$125, an option is available to provide digital outputs compatible with the H-P Interface Bus format. Full input-output capability costs \$800.

Not all of the counter's options add to cost. It is possible to knock \$400 off its basic price of \$3,450 by substituting a room-temperature time base for the ovenized oscillator that comes as standard equipment. Doing so changes the aging rate from less than five parts in 10^{10} per day to less than three parts in 10^7 per month and also reduces the short-term stability (1-second interval) from one part in 10^{11} to two parts in 10^9 . Temperature stability, of course, is also affected. For the range from 0°C to 55°C the drift increases from a maximum of three parts in 10^9 to five parts in 10^6 .

Another \$350 can be cut from the counter's price with an option that eliminates the input amplifiers. This option is appropriate only if the counter is to be used exclusively with plug-in modules.

Extra-cost options include the microwave converter at \$1,950, and the third-channel plug-in at \$850.

The counter's readout is an 11-digit LED display using the HPA division's latest light-pipe design. The digits are 0.4 inch high, and do not have the harsh thin-line appearance associated with the previous generation of directly viewed LED units.

Weight of the 5345A is 37 pounds; maximum power consumption is 200 watts.

Inquiries Manager, Hewlett-Packard Co., 1501 Page Mill Road, Palo Alto, Calif. 94304 [338]

Strength where it's needed!

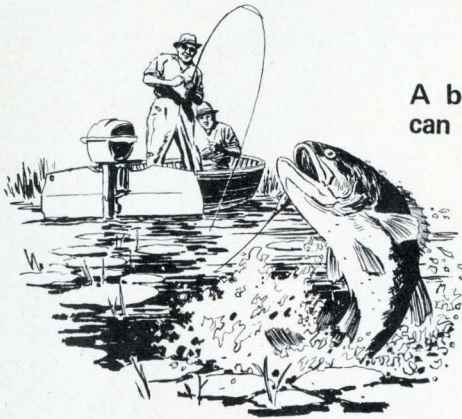

A broken line when you're interconnecting p.c. boards can be disastrous too.

Sure you can catch a 12 pounder on light line. It takes skill. But there's more to it than that. That lightweight, flexible rod is made to take the stress over its entire length. And that is just what you get in Ansley FLEX STRIP® Jumpers. When you flex an Ansley Jumper the pins don't bend . . . the Jumper does.

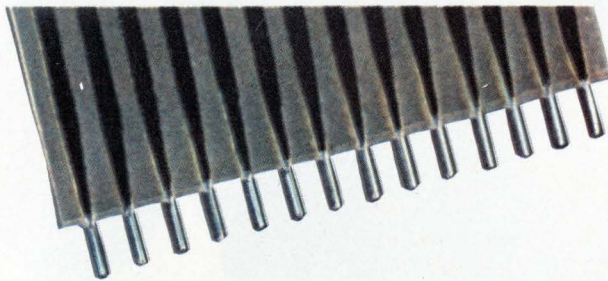

The secret is round pins and flat conductors. Round pins to fit p.c. board hole patterns. Flat conductors for flexibility . . . to take the bends.

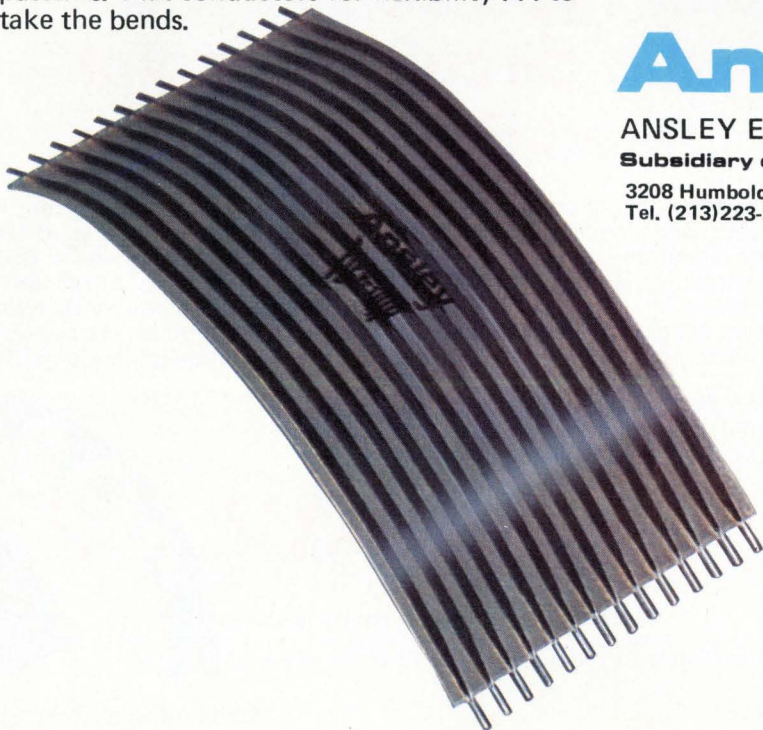

Four insulating materials are available to cover a wide range of temperature (and cost requirements). Nomex*, Mylar*, Teflon*, Kapton* are available. Standard lengths are 1", 2" and 3". Conductor pin spacing can be .050, .100, .125, .150 or .200.

* Dupont Trademark

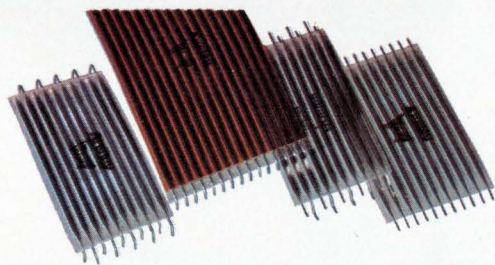

Four pin configurations are also options. Straight, 90° bend, straight or 90° staggered and you have a complete line of the best Jumpers money can buy.

Ansley

ANSLEY ELECTRONICS CORP.

Subsidiary of Thomas & Betts Corporation

3208 Humboldt St., Los Angeles, Ca. 90031
Tel. (213)223-2331, TWX 910-321-3938

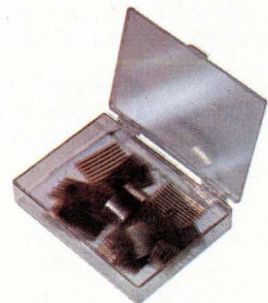

Get a sample and see for yourself.

Circle 123 on reader service card

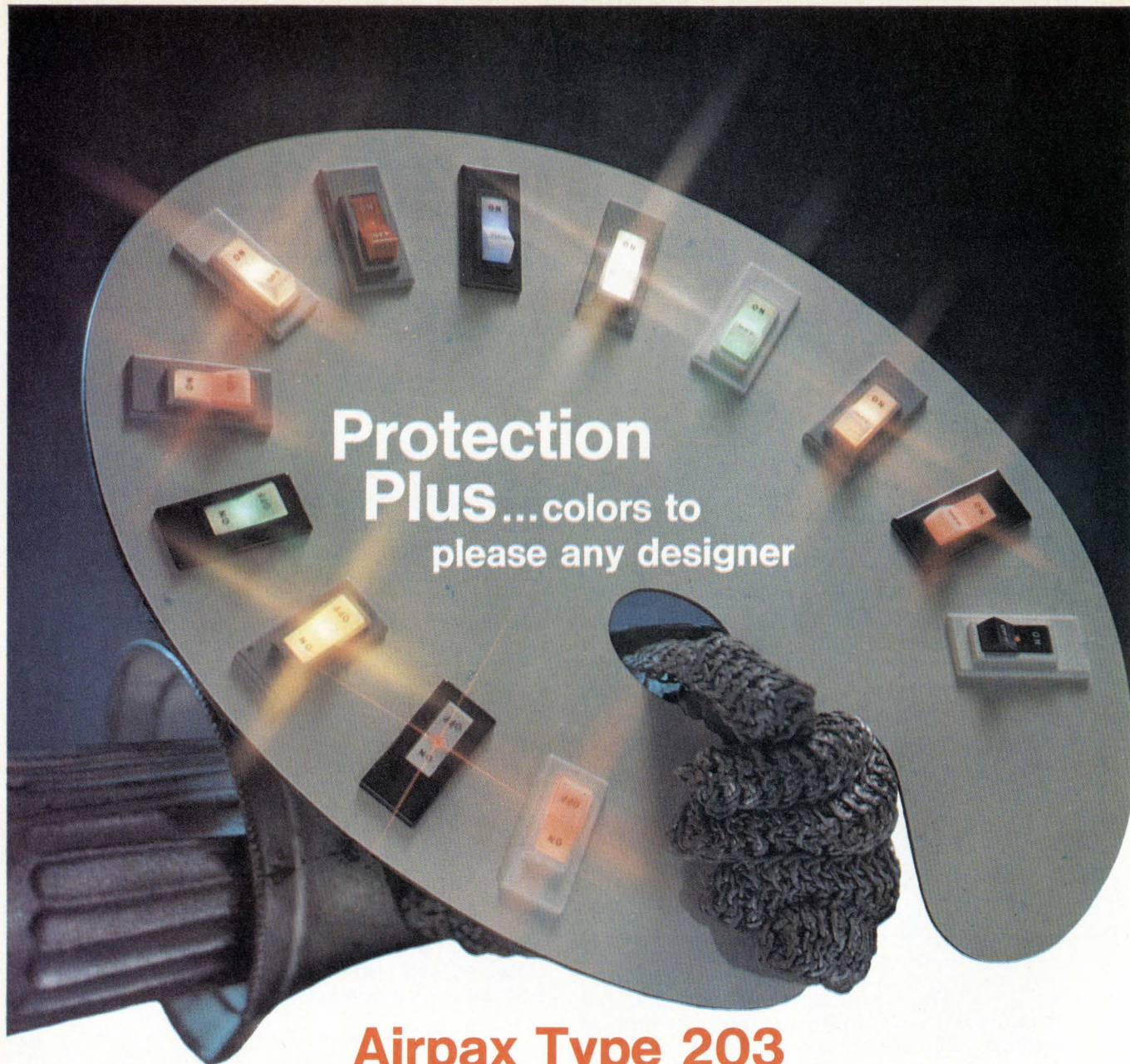

**Protection
Plus...colors to
please any designer**

Airpax Type 203 Electromagnetic Circuit Protector with Illuminated Rocker Arm

Airpax circuit protectors have always offered protection, plus. But now there's an added Plus — Type 203 protectors with illuminated rocker handles in a variety of colors that will enhance the appearance (and sales appeal) of any product or panel.

Combining over-current protection with ON-OFF switch and pilot light functions, the 203 is ideal for

use in high quality consumer, commercial, and industrial equipment where accurate, reliable protection and attractive appearance are demanded.

A choice of many mechanical and electrical configurations provide maximum versatility for the designer. Series, shunt, and relay trip internal circuits are available and can be combined in single, two, and

three-pole versions. Current ratings from 0.02 to 20 amperes at 120V AC and 0.02 to 10 amperes at 250V AC. Inverse time delay or instant trip.

Interested? Write for Bulletin 2009. Airpax Electronics, Cambridge Division, Cambridge, Maryland 21613.

AIRPAX™

Protection comes in many colors



Airpax also manufactures many other types of circuit protectors in current ratings up to 100 amperes.

Peripherals broaden calculator's role

Simple programming language, low price, interfaces help accelerate inroads into minicomputer control of instrumentation and data systems

by Paul Franson, Los Angeles bureau manager

One of the hottest trends in data-handling and control is the use of relatively low-cost desktop programmable calculators instead of minicomputers for many applications [*Electronics*, Sept. 13, 1973, p. 80]. The latest firm to hop into this field is Computer Design Corp., maker of Compucorp 400 calculators and the Monroe 180 series. Computer Design, which has sold about 50,000 sophisticated calculators, is introducing a line of peripherals for these machines, plus interfaces that permit the calculator to control or be controlled by external instruments.

Being introduced now are teletypewriter and typewriter controllers, an X-Y plotter, mark/sense card reader, and cassette drive. Others, including a cathode-ray-tube terminal, are to be introduced shortly. The calculators themselves contain built-in numerical and programming keyboards, numerical printers, and magnetic-card readers.

Calculators have attracted interest, particularly from users outside the computer discipline, both because of their low cost—perhaps \$3,000 instead of \$10,000 for a minicomputer system—and because they can be programmed more easily. Programming of the Computer Design calculators is simple because of familiar mathematical notation plus a few simple English-language commands instead of computer languages or reverse notation.

A general-purpose microcomputer inside the Computer Design calculator contains five LSI packages, can handle 16 input-output devices, can address up to 16,384 bytes of memory (random-access or read-only) and has 250 mi-

croinstructions. Obviously inferior to a conventional minicomputer in speed, its memory read or write time is 80 microseconds, and add time is 160 microseconds. However, this speed appears to be adequate for a vast number of applications, particularly because of the relatively slow response times of both input sensors and output devices found in most small systems. The calculator is now being sold to medical and industrial instrumentation OEMs.

Two of the peripherals now offered plug directly into the calculator without any accessories; the other requires a \$300 adapter, the input/output system Mark I option, which is attached to the rear of the calculator. Peripherals requiring the adapter are the model 492 cassette drive (\$2,000); model 495, a controller for a teletypewriter (\$1,150); and model 494, a controller for the IBM Selectric typewriter. The cassette drive uses standard computer-grade Philips cassettes and can store approximately 307,000 program steps on one cassette. Four cassette drives can be used in one system in addition to other peripherals.

The teleprinter and typewriter interfaces provide full alphanumeric capability for the system. Two can be controlled by the calculator; each, however, requires a separate controller. The Selectric typewriter can be controlled either from the keyboard of the calculator or from a small auxiliary keyboard supplied with the system. The typewriter can also be switched out of the system for independent use.

The teleprinter interface makes possible connection of a Teletype machine, or any other seven- or eight-level ASCII-compatible device,

including a CRT display, medium-speed printer, compatible tape- and disk-memory unit, card reader, and instrumentation. Either a Teletype current loop or EIA-RS-232C standard interface can be used, and the system can be applied to data communications in this mode. For such an application, the controller operates nonsynchronously at 110, 150, 300, or 600 baud, using 10 or 11 bits per character.

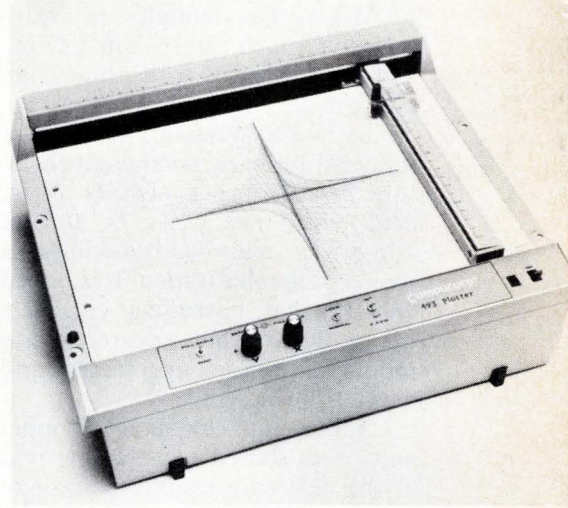

Under direct control. Analog X-Y plotter is one of the peripherals that plugs into calculator, requiring no special interface.

The peripherals not requiring special interface are the model 493 X-Y plotter (\$2,650) shown above, and model 490 mark-sense card reader (\$495). The analog plotter operates at a maximum of 12 inches per second over a 10-by-15-inch range. The card reader will accept both hand-marked and punched input cards.

Computer Design Corp., 12401 West Olympic Blvd., Los Angeles, Calif. 90064 [339]

New products

Packaging & production

Card cage is flexible

Low-cost system takes
mix of circuit-board
modules 1 to 4 inches wide

It requires no more than a screwdriver for a design engineer to alter his packaging configuration—that is, if he is using the flexible card-cage system developed by Vector Electronics Co. of Sylmar, Calif.

Designated the CCM-144, the "universal" enclosure was patterned after the Atomic Energy Commission's nuclear-instrument-module design, which established a standardized system of modules and cages. Unlike the AEC design, the CCM-14A has modules in increments of 1 inch rather than 1.37 in., and it holds cards with printed tab plugs.

The Vector system employs a standard 19-in. rack-mounted enclosure 5-7/32 inches high by 9 in. deep and a mix of 1-, 2-, 3-, and 4-in.-wide circuit-board modules, as shown in the illustration. It is priced low, so that packaging engineers will probably want to carry it into production to save engineering and manufacturing costs.

Captive nuts contained in upper and lower slotted struts in the rear of the enclosure enable the user to station mating connectors on a desired center-to-center spacing. The card guides also attach to slotted struts for easy alignment. The modules themselves mount standard cards 4½ in. wide by 6½ in. deep.

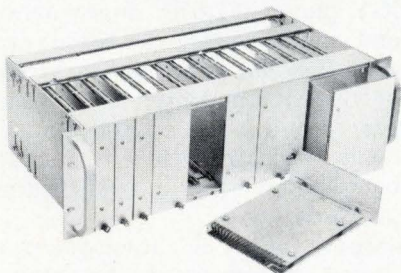

The front panel of the module is removable so that it may be drilled or punched to mount switches, controls and lamps—even after the card itself is loaded. A jack screw on each module secures the module in place, and it jacks the module in and out of the mating connector at the rear of the enclosure.

Unit price for the enclosure is \$43.50, but this drops to \$32.63 each in quantities of 500. Module prices range from \$3.75 (1-in. wide) to \$4.10 (4-in.) for one to nine units and \$2.51 to \$2.75 each in quantities of 500.

Vector Electronics Co. Inc., Sylmar, Calif. 91342 [391]

Programmer handles fusible-link ROMs

The model 813 programmer for read-only memories handles Pro-Log's model 3601 fusible-link ROMs. It has four operating modes: program, list, duplicate, and verify. In the program mode, data is written on the ROM through the keyboard. In the list mode, data is read out both in binary and hexadecimal formats; in the duplicate mode, a ROM can be copied from a master ROM with corrections entered through the keyboard; and in the verify mode, the unit automatically displays ROM addresses and data where master and copy differ. The programmer weighs 14 pounds and is packaged in an attaché case. Price is \$1,450.

Pro-Log Corp., 852 Airport Rd., Monterey, Calif. 93940 [395]

Bagger-sealer handles 1,200 pc boards per hour

A bagger-sealer combination enables a single operator to package more than 1,200 printed-circuit boards an hour. The operator places the board into a bag that has been blown open and then drops the filled bag on to the waiting automatic sealer. The product leaves the sealer as a finished package, so that the board is protected against dirt

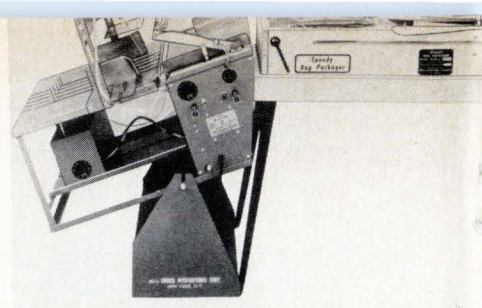

and other harmful materials.

Errich Packaging division, Errich International Corp., 721 Broadway, New York, N.Y. 10003 [394]

Evaporation system has fast pump module

An automatic evaporation system is designed for deposition of pure thin films on 2- and 3-inch wafers. The model 3120 includes a pump module that is said to deliver 25%

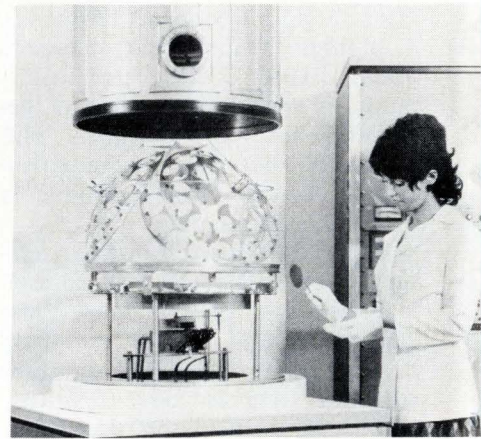

greater speed than other types of pumps. A programmed high-vacuum valve permits transfers from the roughing pump to the diffusion pump at very high pressures, which eliminates backstreaming of oil.

Varian Associates, Vacuum division, 611 Hansen Way, Palo Alto, Calif. 94303 [393]

Logic boards designed for PDP interface needs

A series of logic boards is designed for programming additional logic for the interface requirements of PDP minicomputers to custom systems and peripheral equipment. The boards, which are compatible with Digital Equipment Corp. W-series module boards, provide 85 16-con-

CTC delivers twice the power from DC to daylight.

Which leaves our competitors caught in a power struggle.

We won the battle a long time ago. And what a power trip. Hundreds of watts. Marching bands from 2 MHz to 1 GHz. CTC has captured the market with over 500 transistors. Operating up through 50 watts at 1 GHz, 100 watts in the 225-400 megahertz band, and up to 200w at the low end of the mobile-communications spectrum.

But the real unsung heroes are CTC's radio engineers. A unique group of pros who know better than leaving an engineer strictly to his own devices. Men who can see things from your side, from in-depth experience.

Unlike some semiconductor designers who'll oscillate an amplifier for a small power gain, our guys have put us in the chips with triumphs like Huge Huey. A hefty 180x 266 mil chip that puts out up to 200 w at 28 v. Designed like all CTC assemblies—with infinite VSWR. Which is another reason CTC is such a powerhouse.

But just because we command the field, don't be afraid to give us orders.

Communications Transistor Corporation
301 Industrial Way, San Carlos, California 94070
Phone (415) 591-8921 TWX 910-376-4893

CTC: The power in RF power.



**“ECI lets
good people
grow and
move up
fast.”**

JOE KING,
Senior
Principal
Engineer

“Some companies assign you to a slot and you can't break out. Not here. We want only the top people who want an environment conducive to learning. Here, you can go to the experts in another area and get their help. You just go in and talk it out — there's a lot of interplay. It's really one big group at ECI, instead of lots of little groups.”

**Career opportunities for
electronic engineers:**

We have openings at all levels for electronic engineers experienced in the design and development of communications systems, RF, digital, and modem equipment. You'll be working with major UHF command and control systems, satellite relay and telemetry systems, and a variety of other challenging long-term projects including advanced mail handling systems.

**If your specialty doesn't match
exactly:**

If you're a creative Electronic Design or R & D engineer, really know the fundamentals of electronics, and are highly flexible, we'd like to hear from you. It may well be that you're the man for us.

ECI is on Florida's West Coast in sunny, cosmopolitan St. Petersburg. If you're interested in a career opportunity on long-term programs in a stimulating environment, write in confidence today to William A. Peterson, Personnel Manager, Electronic Communications, Inc., Box 12248, St. Petersburg, Fla. 33733.

ELECTRONIC COMMUNICATIONS, INC.

A subsidiary of NCR
An equal opportunity employer.



New products

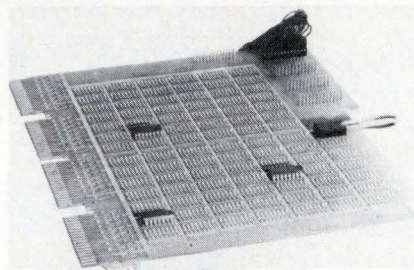

tact patterns for mounting 14- or 16-lead DIP integrated circuits. Three rows of 54 contacts, each on 0.300-inch row spacing, are offered. Further, a total of 274 input-output points for connectors is provided on each board.

Robinson Nugent Inc., 800 E. 8th St., Box 470, New Albany, Ind. 47150 [396]

**Printed-circuit connectors
have 4 dual contacts**

A family of receptacle-type printed-circuit connectors, suitable for grouping in any quantity for various pc-board applications, is designated

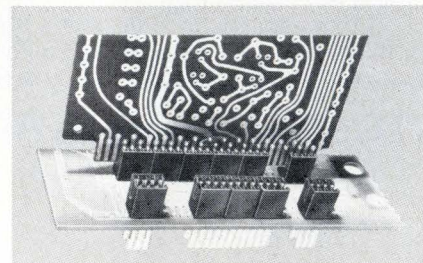

series 6125-250. These connectors feature 0.025-inch-square solderless-wrap terminals on 0.125-inch contact centers. Available with four dual contacts, they accept a 1/16-inch printed-circuit board. Moldings meet military specifications, the company says.

Continental Connector Corp., 34-63 56th St., Woodside, N.Y. 11377 [398]

**Locking clip connector
unmates with one pull**

When mated with 0.025-inch square posts, a locking clip connector cannot be disconnected if wires are inadvertently pulled. Yet the connec-

POWER.

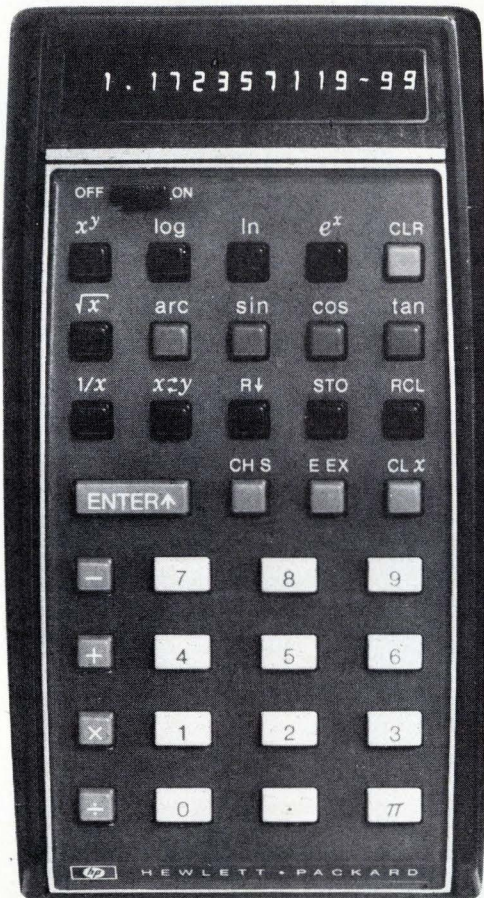

Our HP-35 scientific pocket calculator is pre-programmed to handle 22 arithmetic, trigonometric and logarithmic functions and data manipulation operations beyond the basic four (+, -, ×, ÷). Our HP-45 can handle 44.

The HP-35 lets you store a constant in its addressable memory register. The HP-45 lets you store nine in its nine addressable registers.

Both offer you HP's exclusive 4-register operational stack which automatically stores and retrieves intermediate answers. The HP-45 also gives you a "last-x" register for error correction or multiple operations on the same number.

Both display up to 10 significant digits in either fixed-decimal or scientific notation and automatically position the decimal point throughout their 200-decade range. The HP-45 also lets you round the display to any number of decimal places.

Both weigh in at 9 ounces and come with built-in rechargeable battery packs, so you can calculate wherever you happen to be working.

Most important, both put more calculating power per dollar at your fingertips than any other pocket machine on the market today. So you can rest assured, no matter which you choose, you're getting the best

MORE POWER.

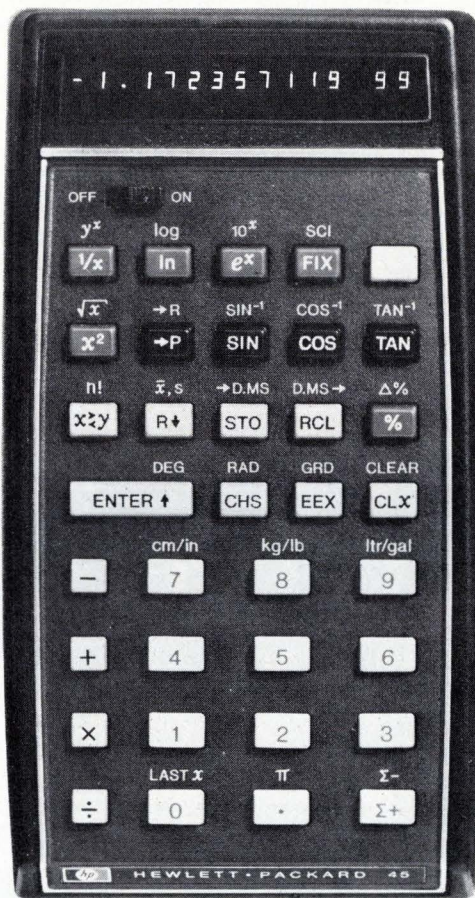

there is for the money. For detailed specifications of either machine or for information on our full line of handheld and pre-programmed desktop calculators, send the coupon. Or call Customer Service at (408) 996-0100.

Hewlett-Packard makes the most advanced pocket-sized computer calculators in the world.

614/01

Hewlett-Packard
19310 Pruneridge Avenue, Cupertino, CA 95014

614/214 D

- Detailed specifications on your HP-35
- Detailed specifications on your HP-45
- HP-35(s) at \$295* each plus state and local taxes (check enclosed)
- HP-45(s) at \$395* each plus state and local taxes (check enclosed)
- Detailed specifications on your full line of handheld and pre-programmed desktop calculators.

Name: _____

Address: _____

City: _____ State: _____ Zip: _____

*USA prices, subject to change without notice. Add state and local taxes.

HEWLETT  PACKARD

Sales and service from 172 offices in 65 countries
Dept 214 D, 19310 Pruneridge Ave., Cupertino, CA 95014

IS AN HONEST DAY'S WORK FOR AN HONEST DAY'S PAY AN OLD-FASHIONED ATTITUDE?

Not in Georgia.

In our smaller towns, you'll find people who are eager to work. People who value good jobs.

Our trainable labor force is estimated at 100,000 strong. And our Quick Start Program will train your employees for you. Free.

Manpower for industry is just one of our many assets. What are some of

the others? Conservative government. Favorable tax policies. And access to your market.

In Georgia, you'll make a good living, and enjoy living—close to cultural centers, big-league cities, and year 'round recreation and entertainment.

Mail the coupon today for more detailed information on Georgia's smaller towns. We're ready to go to work for you.



Georgia Department of Community Development/Industry Division, Dept. EL-44
Box 38097/Atlanta, Georgia 30334

Please send me information regarding Georgia's available labor and free training services.

Name _____	Title _____	Company _____
Address _____	City _____	State _____ Zip _____

New products

tor can be easily unmated by a simple pull on the housing. Contact-to-post retention and removal are accomplished with a stainless-steel contact spring that allows only se-

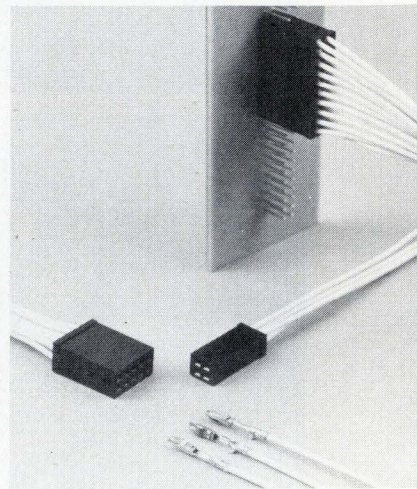

lected forces to act upon it. The connector is supplied in 1-, 2-, 4-, 10-, and 20-contact sizes. Delivery is from stock.

AMP Inc., Harrisburg, Pa. 17105 [397]

GEORGIA

GOOD FOR BUSINESS. GOOD FOR PEOPLE.



LED-mounting hardware aligns automatically

A universal LED-mounting hardware package accepts any dual in-line display with 0.3-inch row spacing. The hardware consists of a one-piece nylon bezel, a circular polariz-

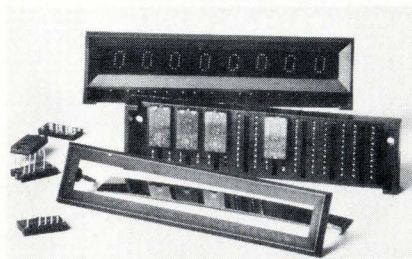

ing window, and a one-piece behind-the-panel socket assembly that eliminates all individual DIP sockets. The display requires only a single panel cutout; no other mounting holes are needed. After installing the bezel into the cutout, the package automatically aligns itself.

Industrial Electronic Engineers Inc., 7720-40
Lemona Ave., Van Nuys, Calif. 91405 [399]

“Scotchflex” Flat Cable Connector System makes 50 connections at a time.

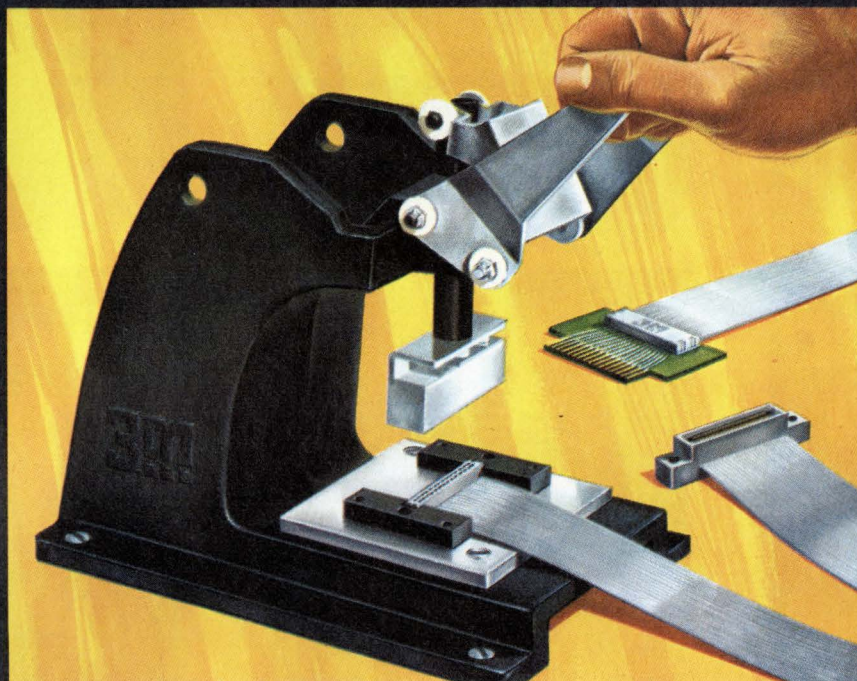

“SCOTCHFLEX” IS A REGISTERED TRADEMARK OF 3M CO.

Build assembly cost savings into your electronics package with “Scotchflex” flat cable and connectors. These fast, simple systems make simultaneous multiple connections in seconds without stripping or soldering. Equipment investment is minimal; there’s no need for special training. The inexpensive assembly press, shown above, crimps connections tightly, operates easily and assures error free wiring.

Reliability is built in, too, with “Scotchflex” interconnects. Inside of connector bodies, unique U-contacts strip through flat cable insulation, grip each conductor for dependable gas-tight connections.

“Scotchflex” offers you design freedom, with a wide choice of cable and connectors. From off-the-shelf stock you can choose: 14 to 50-conductor cables. Connectors to interface with standard DIP sockets, wrap posts on standard grid patterns, printed circuit boards. Headers for de-pluggable connection between cable jumpers and PCB. Custom assemblies are also available on request.

For more information, write Dept. EAH-1, 3M Center, St. Paul, Minn. 55101.



“Scotchflex”.
**Your systems approach
to circuitry.**

SOLVE YOUR CIRCUIT DESIGN PROBLEMS WITH VERSATILE **AlSiMag**[®] CERAMICS



TO GET RID OF HEAT

Substrates of AlSiMag[®] 794 ceramic conduct heat about like the metal aluminum. This remarkable thermal conductivity plus its excellent electrical insulation characteristics and ability to accept metallization have solved many problems of how to dissipate heat from electronic circuits. Bulletin 724 on request.

Phone 615/265-3411.
Telex 558432.

Circle 210 on reader service card

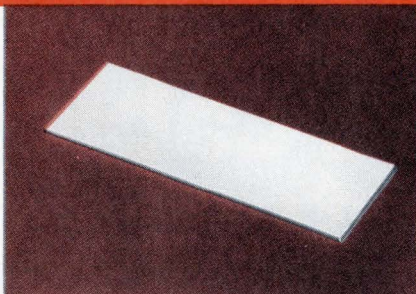

TO MATCH THERMAL EXPANSION OF GLASS

Where a hermetic seal to glass is needed, AlSiMag[®] 842 ceramic can solve your problem. Its thermal expansion closely matches that of the most frequently used glass and forms a reliable hermetic seal. Substrates can be made to the dimensional accuracy you require and with holes, slots, or depressions as needed.

Phone 615/265-3411.
Telex 558432.

Circle 211 on reader service card

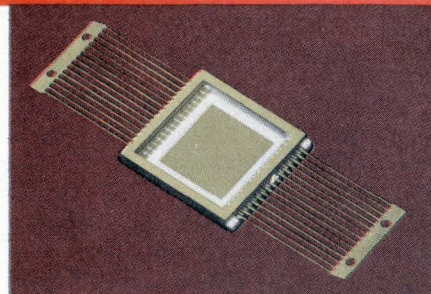

FOR MAXIMUM RELIABILITY

Hybrid packages of all ceramic construction plus brazed-on leads for maximum reliability. Co-fired monolithic ceramic structure eliminates hermeticity problems, greatly increases thermal conductivity and structural strength. Ceramic construction permits mounting the package over conductors on circuit board. Custom made or write for current list of standard packages. Phone 615/265-3411.

Telex 558432.

Circle 212 on reader service card

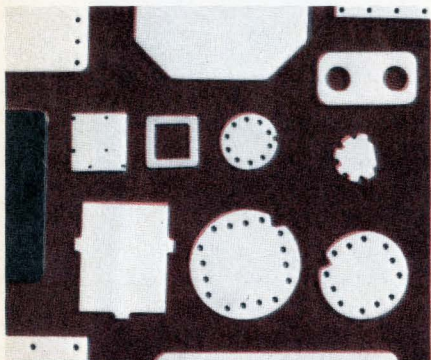

FOR THICK AND THIN FILM CIRCUITS

Extra strong ceramic substrates for thick and thin film processes. Special purpose substrates to get rid of heat, to save space, to match thermal expansion of glass, for light sensitive devices or for a contrasting background. Substrates with high dielectric constants. Bulletin 712 on request.

Phone 803/682-3215.
Telex 570449.

Circle 213 on reader service card

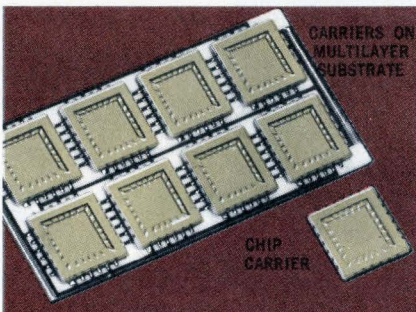

FOR CIRCUIT DENSITY

These small hermetic chip carriers allow for greater circuit density. Electrical testing after hermetic sealing allows storage of good devices in a less expensive package before committing to the circuit. The design permits conventional die attach, wire bonding and lid sealing operations . . . and re-flow solder attachment to a multilayer ceramic substrate, hybrid substrate or phenolic circuit board. Phone 615/265-3411.

Telex 558432.

Circle 214 on reader service card

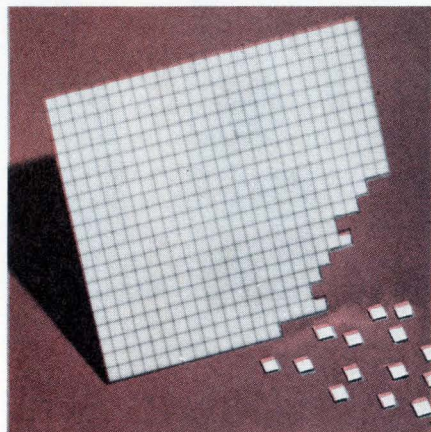

TO REDUCE PROCESSING COSTS

From tooling for economy or from laser for accuracy. Snap-Strates are a proven cost reducer. Have you considered how much Snap-Strates and multiple processing can save you? Bulletin 712 on request. Phone 803/682-3215.

Telex 570449.

Circle 215 on reader service card

You save time and money with single-source responsibility for substrates, pattern generation, metallization and plating.

American Lava Corporation **3M**
A SUBSIDIARY OF COMPANY

Chattanooga, Tennessee 37405 Laurens, South Carolina 29360

INTERNATIONAL: American Lava Corp., Chattanooga, Tenn. 37405, U.S.A., 615/265-3411, TELEX 558432

Data handling

Kit programs calculators

User's set for Wang 600s includes circuit board that can hold eight PROMs

Many top-of-the-line programmable calculators will accept factory-preprogrammed read-only memories to give users access to standard statistical and mathematical programs without sacrificing any internal memory. Now, a small Kansas firm is marketing a do-it-yourself ROM programmer to allow users to write their own custom programs on the Wang Laboratories series 600 programmable calculator.

Available from Midwest Scientific Instruments, the ROM programming kit includes a program and verification module that plugs into the back of the calculator, a printed-circuit board to plug up to eight programmed ROMs into the Wang circuitry, a handheld ultraviolet light for erasing the electrically programmable ROMs, a ROM-programming tape to snap into the Wang cassette drive, and one Intel 1702 programmable ROM. The set sells for \$895, and additional PROMs are available at \$60 each in quantities of seven or more.

"The circuit board containing the ROMs will hold up to eight of them, each containing 256 program steps," says Douglas East, marketing vice president. "This allows for a maximum of 2,048 instructions per board, which essentially doubles the internal memory of the calculator

that is being used in the system."

Since the Wang internal memory is a MOS-type, the programmable ROM prevents the program from being lost when the calculator is turned off, East points out. He adds that several software houses are using the programmer to protect proprietary software, which is easily copied if stored on tape cassettes.

Delivery time for the kit is less than 30 days.

Midwest Scientific Instruments Inc., 1203 Willow Dr., Olathe, Kansas 66061 [361]

Tracer terminal feeds drawing data to computer

Simplifying the process of gathering data from architectural and other drawings, a data tracer is designed to be used with a billing computer as a complete system for cost estimation. Standardizing the data-gathering and cost-estimating process, the system operates without tedious and complicated coding processes of component and materials information. Edge cards are used as the input medium for the cost estimation system.



The component information-selector panel and operation-control console are located in a cabinet above the base table, and the position of the table is adjustable, according to the size of the drawing. The table will accommodate drawings up to 23 by 33 inches. There are 30 component-information selector-card slots on the panel above the table. The edge-card reader and paper-tape puncher are stored in a

roll-away box beside the base table. Connections for linear and counter probes are available on either side of the control console, and a switch control permits both probes to be connected simultaneously.

Power consumption of the data tracer is 200 watts, and weight is 99 pounds.

Hycom, 16841 Armstrong Ave., Santa Ana, Calif. 92705 [362]

Card-punch-interface unit facilitates batch processing

The model CP-100 is an input/output bus interfacing unit that provides punched-card output through installed minicomputers

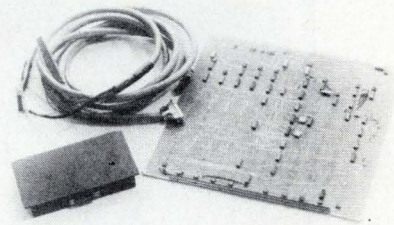

and keypunch machinery without hardware modification. The unit improves batch processing operations in existing installations and data exchanges between processing installations. Minicomputers and keypunch installations can still be used independently. Price is from \$1,975.

Computer Equipment Corp., 14616 Southlawn Lane, Rockville, Md. 20850 [363]

Calculator printer handles 200 lines a minute

With the models 2221 and 2231 printers, Wang calculator users can receive complete alphanumeric printing in two selectable type sizes on standard computer-printout forms. The model 2221 prints a maximum 132-character line at a rate of about 200 lines per minute, while the model 2231 prints an 80-character line at about 150 lines per minute. Both models can print as many as four carbons, and both use

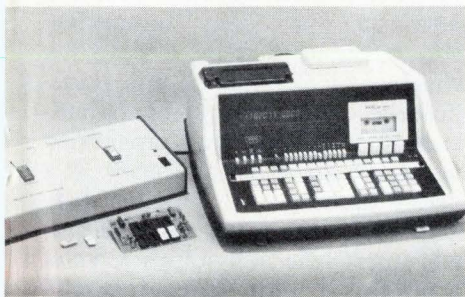

ASSOCIATED WALK-IN ROOMS SYNONYMOUS!

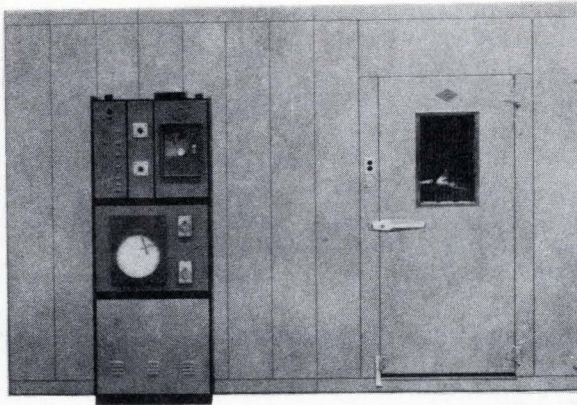

A complete line of environmental rooms by Associated incorporates, as standard, features unmatched in competitively priced rooms! For instance: Temperature ranges from -100°F to $+180^{\circ}\text{F}$... Modular construction for easy installation... Humidity capabilities as wide as $10 \rightarrow 98\% \pm 2\%$ RH or better... Exclusive Conditionaire Module... Solid state instrumentation from on/off controllers to programming by computer... and a complete size range from $3' \times 5' \times 6'$ to unlimited.

If there's no existing Associated Walk-In Room to meet your needs, ASSOCIATED WILL DESIGN ONE TO FIT YOUR EXACT SPECIFICATIONS.

Complete Walk-In Room Catalog available upon request.



associated environmental systems

360 MERRIMACK ST., LAWRENCE, MASS. 01802 • (617) 683-9501
DIV: CRAIG SYSTEMS CORP.

New products

a dot-matrix format. Price of the model 2221 is \$5,000 and of the 2231, \$3,200.

Wang Laboratories Inc., 836 North St., Tewksbury, Mass. 01876 [364]

Magnetic-tape system is designed for PDP-11s

The series 42 magnetic-tape system is available with one to six drives per system. The controller is a quad printed-circuit board, which is installed into a PDP-11 small-peripheral-controller slot or wired-system unit. The controller is also cabled to the slide-mounted chassis,

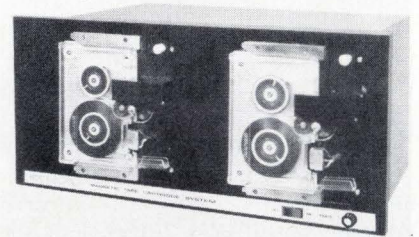

which contains one or two 3-M cartridge tape transports, power supply, and formatter. Cartridge capacity is 720,000 bytes per track, and transfer rate is 48,000 bits per second. Price is \$3,150 for a single-track unit.

Applied Data Communications, 1509 E. McFadden Ave., Santa Ana, Calif. 92705 [365]

Data-acquisition system aids testing functions

A computer-calculator-based data-collecting and -processing system, designated the model DA-106, is a measuring, processing, formatting, and recording system. It covers a wide range of electrical and transducer-test and measurement parameters, data-logging, and programmed test capability. The unit consists of a digital multimeter, a modified H-P-9830 computer-calculator, and system interfacing and software. Data being gathered can be sent to a tele-

The Total Performance Pocket Slide Rule Computer!

Solves advanced scientific/engineering problems with split-second accuracy.

Forget everything you've read or heard about previous calculators. This phenomenal multi-function instrument from Lloyd's does more than just add, subtract, multiply and divide. Its built-in capacity also includes almost every conceivable slide rule function—plus a few that ordinary slide rules can't perform at all! It's really the ultimate calculator value for the scientist, engineer, mathematician, accountant, teacher, or any math-using professional.

Just look at the versatile capabilities that this remarkable computer puts in the palm of your hand:

TRIGONOMETRIC FUNCTIONS IN DEGREES OR RADIAN

The Accumatic™ 999 can instantly give you the sine, cosine, or tangent of any angle, as well as the inverse of any of these functions. (i.e. arc sine, etc.) And an exclusive degree/radian conversion switch allows you to compute in radians as well as degrees—a feature unavailable on most other slide rule calculators.

EXPONENTIAL FUNCTIONS

Natural logarithms ($\ln x$), natural antilogarithms (e^x), common logarithms ($\log x$), common anti-logarithms (10^x), square roots (\sqrt{x}), reciprocals ($\frac{1}{x}$), and powers of numbers (x^y) are all easily computed on the Accumatic 999 at the touch of a button.

FULLY ADDRESSABLE MEMORY BANK

In addition to its "display" register and its separate "constant" register, the Accumatic 999 has a fully addressable memory bank that is the most advanced available to date. An $(m+x^2)$ key automatically squares a number and enters it into memory—very handy for finding the hypotenuse of a right triangle when the other 2 sides are known. It also has 5 additional memory keys to perform other memory functions.

WIDEST VERSATILITY

With: Pi (π) key; multi-purpose clear (C) key; data recovery key (DR); change sign key (+/-); eight digit Digitron® display (superior in legibility to LED'S); overflow and negative number indicators; wrap-around decimal; and more.

AC/DC OPERATION

The Accumatic 999 operates off 4 long-life alkaline rechargeable batteries. And a combination AC adapter and battery charger lets you save the batteries and run the instrument off 120 volt AC house current when you're near an outlet. AC adapter/charger and batteries are included with the unit.

WHO MAKES THE ACCUMATIC 999?

If accuracy and reliability are of critical importance in your professional computations, it should reassure you to know that the

Accumatic 999 is manufactured to Lloyd's specifications by one of America's leading aero-space engineering companies: Rockwell International. And the Lloyd's one-year warranty on this product is further assurance that your purchase is backed by a leading company in the consumer electronics field.

HOW MUCH DOES IT COST?

If you've been shopping around for a slide rule calculator, you probably know by now that you would have to pay at least \$300 for an instrument like the Accumatic 999. But through Lloyd's we are able to offer you this total performance calculator at a remarkably low price.

ONLY
\$199.95

Batteries, AC adapter/charger, comprehensive instruction manual, and a handsome padded carrying case are all included in the total purchase price.

**Order Today
For Prompt
Delivery!**

Please rush me _____
Lloyd's Accumatic™
999 calculators @
\$199.95 each, complete with batteries,
AC adapter, and case.
I enclose full payment
of \$ _____

(Add \$2.75 for handling and shipping. N.J. residents add 5% tax.) I understand that if I am not absolutely satisfied, I may return my purchase within 15 days for an immediate FULL REFUND.
Make check or money order payable to:
Austin-Whyte Co. Allow 2 weeks for delivery.

Name _____

Address _____

City & State _____

Zip _____

Mail to: **Austin-Whyte Co.**

224 Midland Avenue Saddle Brook, N.J. 07662

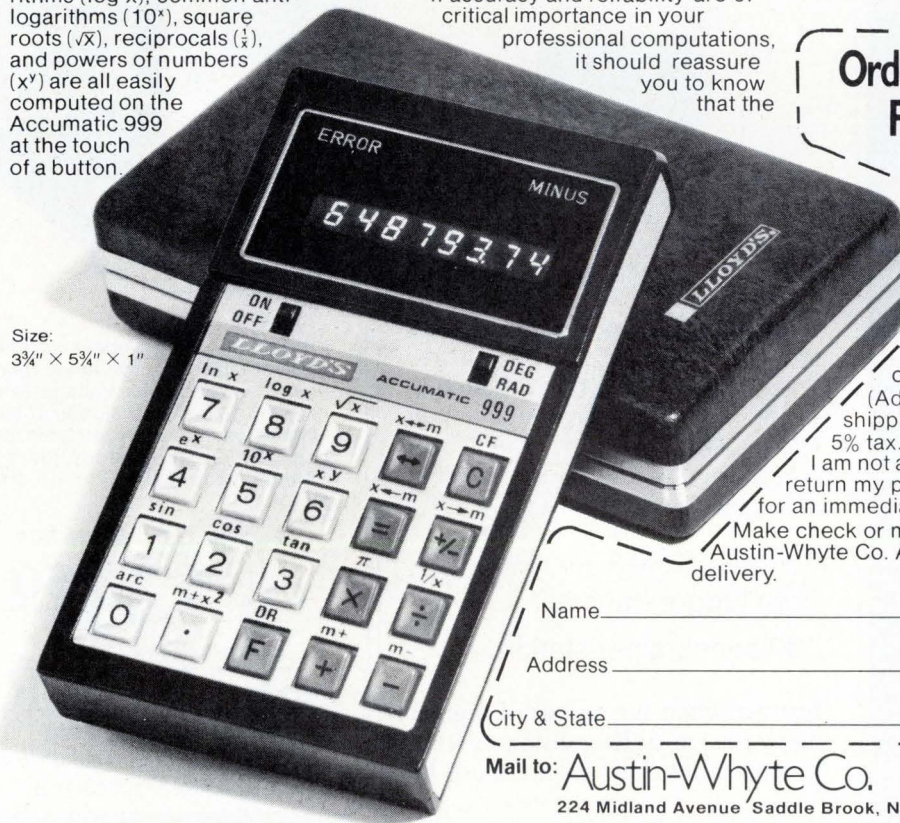

Size:
3 3/4" x 5 3/4" x 1"

COMPARE

DAHMEN BURNETT MAKES DRIVERS BETTER, OR CHEAPER, OR BOTH

At the risk of sounding a little pleased with ourselves, we'd like to point out some comparisons between our stepper motor drivers and others:

Cheaper

Superior Electric's STM1800CV is catalog priced at \$128.

Dahmen Burnett's model D-120, a pin-for-pin replacement, sells for \$85.

Better

Phillips' model 9904-131-03004, a standard off-the-shelf driver.

Dahmen Burnett's model D-110, also off-the-shelf, but featuring *total noise rejection*.

Better and Cheaper

Icon Corporation's QFA and QP6, a two-card assembly, fairly priced.

Dahmen Burnett's D-20 driver, all on one card at 10% less cost.

These are but three examples. If you want proof of other Dahmen Burnett drivers, translators, and computer interfaces... all made better, or cheaper, or both... ask for our packet of data sheets. It's the whole story.

DBE

**DAHMEN BURNETT
ELECTRONICS, INC.**

Grenier Industrial Village
Londonderry, N.H. 03053
Tel: 603-668-2777

New products



typewriter, CRT terminal, or thermal printer.

Julie Research Laboratories Inc., 211 W. 61st St., New York, N.Y. 10023 [366]

Thermal printer offers
155-mil slanted characters

The BS-015 series of numeric seven-segment thermal printheads for use in nonimpact printing features 155-mil slanted characters, especially

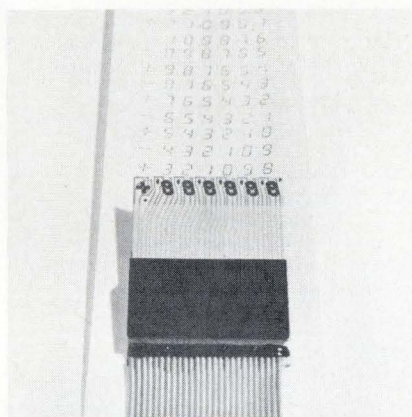

configured for data-logging applications in instruments and recorders. Characters are interconnected for multiplexed operation. Standard units are available with four to seven digits. Prices range from \$21 to \$90, depending on configuration and quantity.

Gulton Industries Inc., Electronic Components Division, Metuchen, N.J. [367]

Data logger handles
200 sensors per station

For use when the output of a great many sensors at long distances from a central logging system must be

1
AMERICAN MADE

Tolerance
SCHAUER
1-Watt
ZENERS

**Immediate Shipment
Low Prices**

ANY voltage from 2.0 to 16.0

Quantity	Price each
1-99	\$1.07
100-499	.97
500-999	.91
1000-4999	.86
5000 up	.82



All welded and
brazed assembly

No fragile
nail heads

Gold
plated
leads

Write for complete
rating data and other
tolerance prices.

**Buy the kit-
Save
a lot**

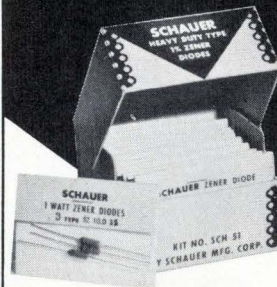

Kit contains a 51-piece assortment of SCHAUER 1% tolerance 1-watt zeners covering the voltage range of 2.7 to 16.0. Three diodes of each voltage packaged in reusable poly bags. Stored in a handy file box. Contact your distributor or order direct.

A \$54.57 value for
ONLY \$24⁵⁰

Semiconductor Division

SCHAUER
Manufacturing Corp.

4514 Alpine Ave. Cincinnati, Ohio 45242
Telephone: 513/791-3030

Just a few years ago, there were no commercial logic circuit testers in use. Now, over 400 are at work throughout the electronics industry. Because their rather dramatic contribution to increasing throughput, lowering testing/troubleshooting costs, and improving product reliability has been repeatedly proven.

That's not to say that every tester in every application made such a contribution. Quite the contrary. A lot of other things need to be done, and done right, to get the most out of logic testing. System integration. Test languages. Software. Perhaps some new wrinkles on test generation, fault isolation, even fabrication or design.

We know. MIRCO has been in logic testing for years. Solving problems for major companies worldwide (including most of the leading test system manufacturers). We've learned the value, indeed necessity, of a total approach to this testing business over and over again.

So now we offer it. MIRCO test programming, test generation software, test systems, fabrication and design consultation. Backed by some of the best brains in the industry in every one of those categories.

You can buy us in pieces, of course. But better yet, before you buy anything, ask us for a custom analysis of your whole testing situation. We'll tell you what MIRCO pieces can save you most. And prove it. Or — we'll tell you that your setup is optimum right now. And go away. Once you get a taste of our total approach to logic testing, we know you'll ask us back.

Our best logic circuit tester (or anyone else's) is no panacea

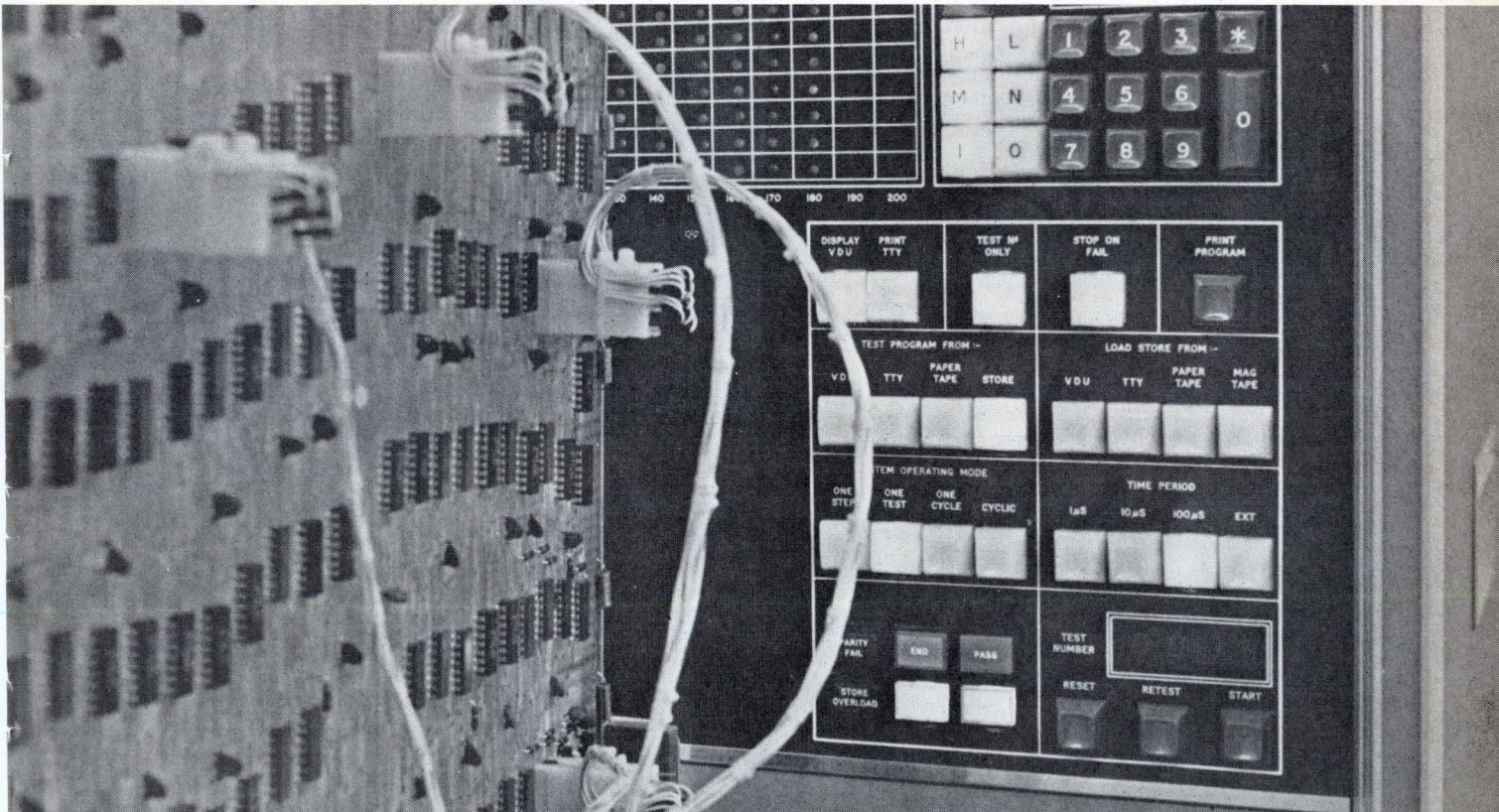

MIRCO 410 Logic-Circuit Test System

MIRCO

MIRCO SYSTEMS, INC.
2106 W. Peoria, Phoenix, Az. 85029 • Phone (602) 944-4691
The only name you need to know in circuit testing

See us at
Booth 5011,
NEPCON/WEST

Circle 137 on reader service card

IMMEDIATE DELIVERY!
IN STOCK

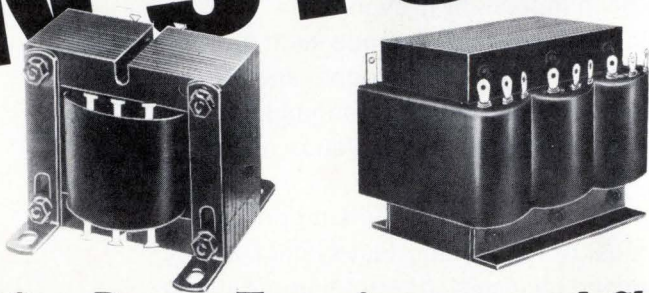

Rectifier Power Transformers and Chokes

SIGNAL HAS THE LARGEST SELECTION OF OUTPUT RATINGS AVAILABLE.

- Most Economical—No Minimum order Requirement.
- Ideal for Single or Dual DC Supplies.
- Wide Diversity of Ratings—5 to 300V, 0.1A to 200 Amp.
- Very High Current Units Up to 1000 Amps, Single and 3 Phase.

**Signal
transformer co. inc.**

1 Junius St., Brooklyn, N.Y. 11212
Telephone (212) 498-5111

Send for Free Catalog also listing extensive lines of Printed Circuit Plug-In Transformers, Flat Plug-Ins and Constant Voltage Transformers.

Circle 138 on reader service card

Why mess around when you can have the **ELECTRONICS BOXER** clean up your copies—keep them in top condition.

And, it's easy and

inexpensive to keep the **ELECTRONICS BOXER** in your corner. Just complete the coupon and mail. Your order will be processed immediately, postpaid.

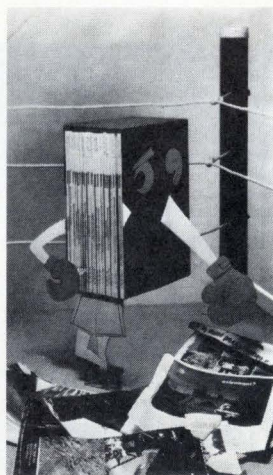

ELECTRONICS BOXER

Jesse Jones Box Corporation

2250 E. Butler St., Philadelphia, Pa. 19137

Please send me: boxes @ \$4.25 each;
 3 boxes @ \$12.00; 6 boxes @ \$22.00

My check or money order is enclosed.

Name _____

Address _____

City _____ State _____ Zip _____

PUBL. SERVICE



SALON INTERNATIONAL DES

**composants
électroniques**

PARIS 1-6 / 4 / 74

COMPONENTS - MEASURING
MATERIALS - EQUIPMENT

Organisation S.D.S.A. - 14, rue de Presles 75740 Paris Cedex 15

FRENCH TRADE SHOWS 1350 Avenue of The Americas
NEW YORK, N.Y. 10019 Tel.: (212) 582-4960, 1

New products

measured, monitored, and recorded, the model 90GP34 data logger employs a number of satellite stations, each capable of handling 200 sensor outputs. This eliminates the problem of running separate wires from each sensor to the central data station. Each satellite accepts the out-

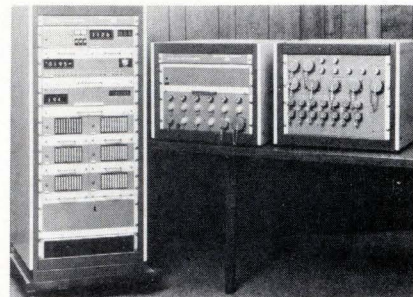

put from all transducers in its vicinity, and then only 11 conductors are run from the satellite to the central data station—two to carry data and nine to carry BCD commands.

Consolidated Controls Corp., Bethel, Conn. 06801 [368]

Tape-reader-punch operates at 70 characters per second

The model 7470 paper-tape-reader-punch perforates Mylar or paper tape at 70 characters per second. The unit reads synchronously at 400 characters per second and asynchro-

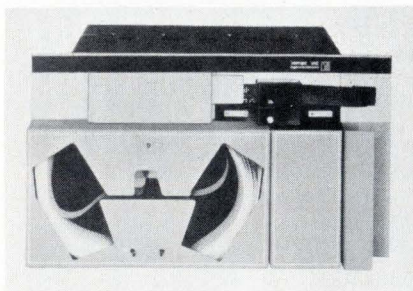

nously at 300 characters per second. Capacity of the model 7470 supply bin is 1,000 feet or 120,000 characters for the punch; a 140-foot take-up capacity or 16,800 characters for the punched tape; and a 140-foot fanfold bidirectional bin for the reader.

Iomec Inc., 3300 Scott Blvd., Santa Clara, Calif. 95050 [369]

TIGHT?



WRITE.

There's plenty of room for growth in Québec. This coupon could be your key to wide-open expansion opportunities.

We've taken the lid off the TELECOMMUNICATIONS AND COMPUTER industry in Québec. Researched our assets thoroughly. Identified some exciting investment and expansion opportunities. We've compiled the information you need — everything from labor data to market availability — in one concise, comprehensive report prepared for us by Fantus, the largest firm of location consultants in the world. And we've made it easy for you to get together with the Québec Department of Industry and Commerce — in Boston, Chicago, Dallas, Los Angeles or New York.

Write. And we'll send you the facts. Québec. We're interested in the same things you are.

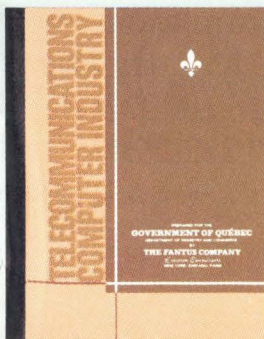

 **Québec**

name _____

company _____

address _____

Department of Industry and Commerce
1 Place Ville Marie, Montréal, Québec

E-1

Circle 139 on reader service card

"Packaging for FOX 2 process computer systems had to be fast, flexible, reliable and low in overall cost."

"Only one company met all our requirements. Augat."

John Hatch, Packaging Engineer,
The Foxboro Company

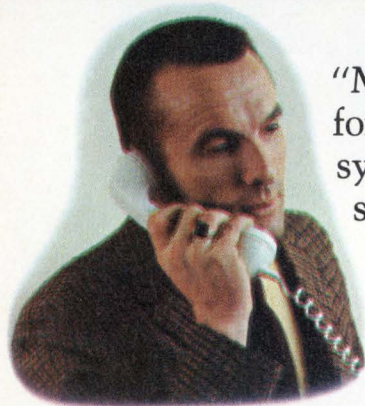

John Hatch

"My responsibility for the new FOX 2 systems was to help select the packaging and connection system providing top reliability plus the fastest possible development time.

On top of that, we wanted maximum density for the system.

"We chose the Augat Company for a variety of reasons. They were willing to work with us in developing new plug-in panels to meet our special requirements. Also, Augat offered the broadest range of I.C. interconnection products (from panels to frames to tools). This combination enabled us to design our packaging to meet our density needs. In fact, with Augat we succeeded in saving almost 90% in space. And access to both front and back planes was easier.

"I was most impressed with Augat's reliability and quality. Because Augat precision-machines the sockets used in their panels, we found our components and D.I.P.'s were easier to insert,

had greater positive contact retention and better corrosion resistance.

"True, Augat panels were probably a little more expensive initially. But from an overall systems standpoint, Augat's superior quality more than offset this small difference. We're sold on the Augat packaging system."

More and more companies like Foxboro are discovering that the name Augat is synonymous with quality, reliability, and service. With good reason. Augat pioneered the wire-wrapped socket panel concept. So Augat has more experience than anyone else in the business.

We'd like to show you how we can provide your company with a better interconnection system at a lower overall cost. Call or write us today. We'll send a free catalogue and complete product information.

Augat, Inc., 33 Perry Ave.,
Attleboro, Mass. 02703.
Phone (617) 222-2202

(See us at NEPCON West, Booth #1010.



The FOX 2

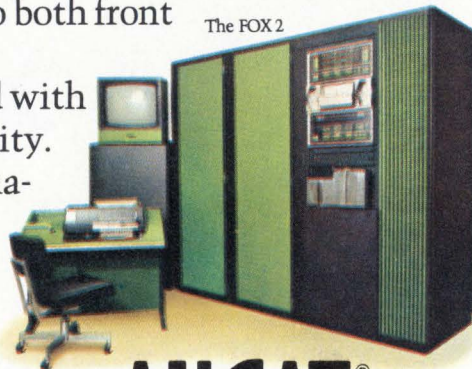

AUGAT®

Europe - Augat International, Inc., Boulevard A. Reyers, 103, 1040 Brussels, Belgium, Tel. (02) 36-93-99.

Japan - Kyokuto Boeki Kaisha Ltd., New Otemachi Bldg., 2-1, 2-Chome Otemachi, Chiyoda-Ku, Tokyo 100-91, Japan, Tel. (03) 244-3788.

Circle 140 on reader service card

Semiconductors

C-MOS circuits offer high drive

Isoplanar 4000-line units also provide improved switching characteristics

For a so-called standard logic family, 4000-series C-MOS is far from standard. In particular, output drive—a parameter that may govern system layout and performance—varies widely from device to device. It varies as much as five to one among different types within RCA's original family and up to six to one among second-sourced types on the market.

And now, Fairchild Semiconductor's new 34000 series will increase the second-source spread to as much as eight to one. However, Fairchild offers some cogent reasons for stirring the C-MOS stewpot once again. Fairchild has opted to copy RCA's logic designs with Fairchild's Isoplanar dielectrically isolated line because the 4000 series is sold more widely than competing C-MOS families. But the specifications are something else.

Explains Robert Walker, who helped draft the specs as a member of Fairchild's product-planning staff: "C-MOS is such a hodgepodge that we decided to start with conventional 4000 logic formats, rather than new configurations. But, since we would be the last people on the market (Fairchild was preceded by RCA and six major second-sources), we wanted a 4000-series with consistent TTL-like drive characteristics. So, we've planned what we believe will comprise the mature 4000 family in a few years."

To attain that consistency, Fairchild adopted as a family spec for both commercial and military parts a worst-case, low-output-current specification of 0.4 milliamperes. Under typical conditions, the drive is around 0.8 mA. The worst-case current, measured at 0.4 volt with the

V_{DD} supply at 5 v, matches Motorola's military-family spec and is twice Motorola's commercial-family spec.

Other specs also depart from the original ones. The most dramatic change can be seen in the input/output voltage-transfer curves. In place of the conventional S-shaped curves, the Fairchild units show square waveforms; that is, output rise times are essentially independent of input waveforms. Combined with the high-drive spec, this means that problems of input-pattern sensitivity and slowdowns of pulse fronts as they propagate through a logic chain are virtually eliminated, Walker claims.

The improvements in drive and switching characteristics may not be very noticeable when different families are operating under the standard test conditions, Walker emphasizes. However, he argues that those conditions—input rise time of 20 nanoseconds or less and output capacitance of 15 picofarads—rarely represent actual system-operating conditions.

"You can count on 20 ns only from a pulse generator. The rise times can go much higher when devices have high fanout and real loads. That 15 picofarads is a hold-over from the DTL days when everybody wanted to make their devices look good, and 15 'puffs' was the lowest capacitance available in test jigs."

Using those test conditions, Walker continues, Fairchild's gate-propagation delays are some 20%

shorter than the original 4000 specs. But at the more typical, although unspecified, system-load conditions of 50 to 100 pF of line and following-input capacitances, "we are 50 to 100% faster" because of the high output current. The drive also makes the series, like a few others, more TTL-compatible than the original 4000 C-MOS. Both low-power TTL and low-power Schottky TTL can be driven directly.

These changes are fallouts of the Isoplanar process whereby oxide-isolation replaces the conventional guard-ring diffusions. The savings in chip area are used, in part, to add two inverter-like buffer stages at each logic output. The buffers give an over-all voltage gain of more than 10,000. In addition, the reduction of on-chip parasitic capacitances cuts the propagation delay [*Electronics*, Jan. 10, p. 33].

Fairchild has also modified the noise-immunity spec "to make it less confusing to the engineer unfamiliar with MOS." As a result, instead of immunity's being related to power-supply limits, the supply is considered stable, and immunity is specified with respect to worst-case inputs and outputs. It is guaranteed across the temperature range at 1.5 v when V_{DD} is 5 v and at 3 v when V_{DD} is 10 v.

Fairchild is introducing the series this month with military parts and will have commercial parts in stock late this month or in February. The initial inventory and 100-up prices for military types are: 34001, quad two 2-input NOR gate, \$3.30; 34011,

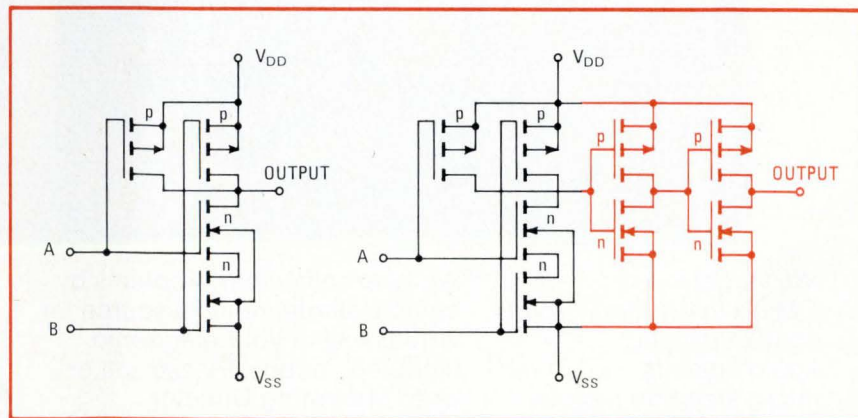

More drive. Conventional NAND gate (left) needs separate buffer chip for high-drive applications. Fairchild Isoplanar version includes buffer (in color) in smaller chip area.

Give your switches a better-than-outside chance.

Keep them safe from the destructive elements that can stop switch performance cold. APM makes it easy, with molded leak-proof seals that shrug off dust, dirt, gas and liquid contaminants . . . stand up to pressures and temperatures that can put undefended switches out of business.

They're the Clean Fighters—a team of custom-molded boots that seal out trouble for all pushbutton, toggle and rotary switches.

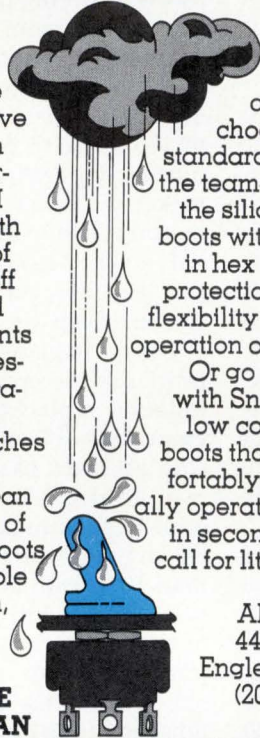

THE CLEAN FIGHTERS
APM-HEXSEAL
DIVISION OF APM CORPORATION

For critical applications, choose the MIL-standard member of the team—Hexseals®, the silicone rubber boots with a molded-in hex nut for extra protection, complete flexibility for fingertip operation of the switch.

Or go commercial with Snapseals®, the low cost neoprene boots that snap comfortably over manually operated switches in seconds. Write or call for literature and samples:

APM-Hexseal
 44 Honeck St.,
 Englewood, N. J.;
 (201) 569-5700.

Circle 142 on reader service card

Easy Access At Newest Plant Site In Rochester, New York

The Outer Loop Industrial Park is right next to a freeway system that connects you with the New York State Thruway and the World. Expressways also lead you straight to the profitable Rochester market.

Neighboring companies know the benefits of this fine location on Rochester's west side. Some of them are Eastman Kodak, Bendix Corporation, 3M Company, General Motors, and Ragu Foods.

Railroad service is available on-site and an airport served by three major airlines is minutes away via the freeways. The Port of Rochester, a few miles to the north, has deep water accommodation for ocean-going vessels.

For more information, contact Robert J. Hall, Director of Area Development, Rochester Gas and Electric Corporation, 89 East Avenue, Rochester, New York 14649 or call (716) 546-2700, ext. 2466.

We know more about sites in our nine-county area than just about anyone else. Contact us for information on available facilities from 10,000 to 800,000 square feet.

RGE AND **ROCHESTER GAS AND ELECTRIC**
89 EAST AVENUE, ROCHESTER, N. Y. 14649 • 546 2700

Circle 169 on reader service card

If you've got the timepiece, we've got the electronics.

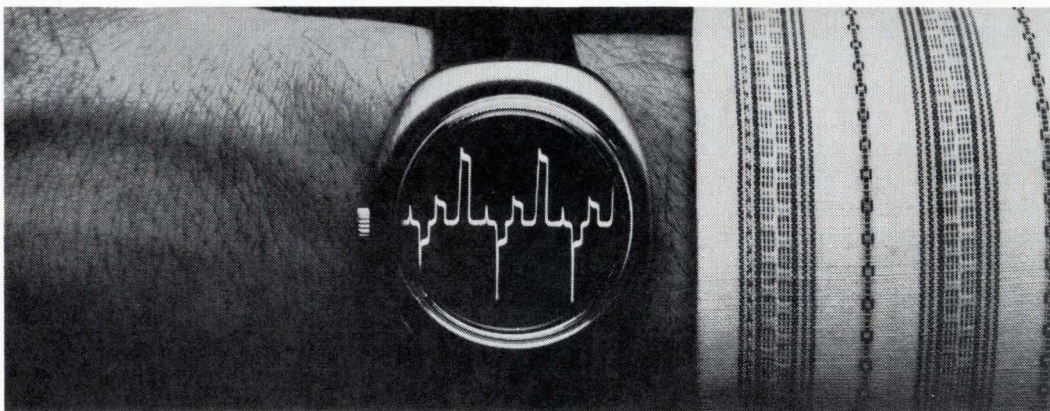

We've got
 CMOS integrated circuits.
 quartz crystals.
 liquid crystals.
 micro stepping motors.
 analog systems.
 digital systems.

We help solve your problems by being a single, reliable source for virtually all of your electronic timepiece needs. Please call or write Marketing Director Motorola Timepiece Electronics, 3102 North 56th Street, Phoenix, Arizona 85036. (602) 244-4406.

MOTOROLA
Timepiece Electronics
Bringing more than 45 years of electronic experience to the world's watch makers.



142 Circle 170 on reader service card

Electronics/January 24, 1974

New products

quad two-input NAND gate, \$3.30; 34012, dual four-input NAND gate, \$3.45; 34023, triple three-input NAND gate, \$3.40; 34030, quad exclusive-OR gate, \$3.79; 34811, quad exclusive-NOR gate, \$3.80.

Fairchild Semiconductor, a division of Fairchild Camera & Instrument Corp., 464 Ellis St., Mountain View, Calif. 94040 [411]

Power Schottky diode is rated for 125°C

A power Schottky diode, rated for a junction temperature of 125°C, is designated the model SD-51. The device is also specified at 50 amperes average forward current with a forward voltage of 0.5 v at the junction temperature of 125°C, which is said to be 25% more than the operating temperature of conventional Schottky diodes. This is possible through the use of a special metal alloy as the bonding layer in the silicon-to-metal junction. Price is \$9.91 each for 1,000-lots.

TRW Semiconductors, 14520 Aviation Blvd., Lawndale, Calif. 90260 Z[415]

Water-cooled heat sinks improve rectifier efficiency

A series of power rectifiers and SCRs are fabricated with water-cooled heat sinks. These water jackets are cast from solid copper, which is said to help eliminate cracks, voids, and leaks that are possible with brazed heat sinks. Furthermore, the new heat sinks are claimed to be typi-

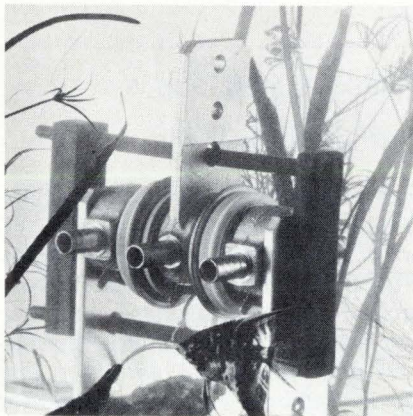

TEFLON* TERMINALS/JACKS

STANDARD & CUSTOM

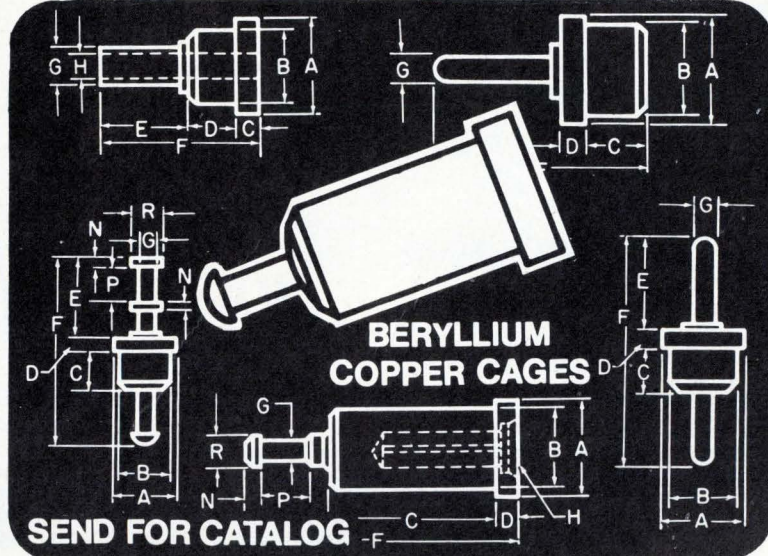

* Registered Trademark E. I. DuPont de Nemours & Co.

CONCORD ELECTRONICS CORPORATION

37 GREAT JONES STREET, NEW YORK, N. Y. 10012
(212) 777-6571 TWX 710-581-4930

Circle 143 on reader service card

The tough little competitor can deliver. Fast.

Call us on your OEM power supply requirements.

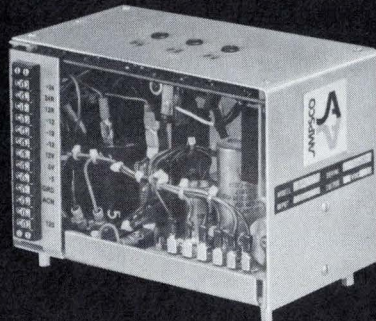

Typical Specifications— MO Series

\$130.00 (liberal quantity discount available)

Up to 4 outputs	2-2.5 Amps
3.8-6. OVDC	150-300 Ma
±12-18 VDC	1-1.5 Amps
+18-26 VDC	
Line and Load Regulation	0.1%.
Operating Temperature	-20°C to +55°C
	No derating
Ripple and Noise	4MV RMS MAX
Other voltages and currents available.	



Mighty Mouse © Viacom International

SALIENT FEATURES

- exceptional reliability
- exceeds computer grade specifications
- packaged for computer peripheral equipment
- meets U.L. and C.S.A. requirements

All standard supplies available in both discrete and I.C. versions. Liberal mix or match discounts available. All AMPSCO products are backed by unconditional 10-year guarantee.

Power Supplies by
AMPSCO
WBSCO

A Tough Little Competitor

American Power Systems Corp. • 51 Jackson St. • Worcester, Massachusetts 01608 • (617) 753-8103



Printact®

Plugs into your PC board... mates with plated conductors

The unique design concept of the Printact magnetic latching and non-latching relays provides $5.0\mu\text{v}$ thermal EMF, 45-65 db cross talk isolation, 0.5ms contact bounce and other custom features as standard at no extra cost. The single moving part is the pivoting armature with series break contacts held by a permanent magnet eliminating return springs, mechanical linkage and pigtail connections thus assuring reliable performance for many millions of cycles.

For a sample and/or data, write or call 212-EX 2-4800

Printact Relay Division, Executone, Inc., Box 1430E Long Island City, N.Y. 11101
Circle 144 on reader service card

MAGNETIC RELAY
with
Custom Features

- Low Thermal EMF
- 45-60db Isolation
- Low Contact Bounce
- Encapsulated Coil
- Bifurcated Contacts

At No Extra Cost!

Available with 6, 12 or 24 VDC coils (0.5 watt G series, 1.0 watt LD series) in 2, 3 and 4 pole configuration. Series break swingers permit each pair of fixed contacts to be etched with common (Form C) or isolated (Form A plus Form B) switching between make and break circuits.

Send for catalog, 2X and 4X artwork stick-on contact patterns and Technical Notes PR262-D, which assist in simplifying PC board artwork, fabrication and procurement.

New products

cally three to six times more efficient than air-cooled heat exchangers. Tabs are available as an option, so that resistors, capacitors, and surge suppressors can be mounted directly across the devices. The heat sinks are available individually or as a complete set with the rectifiers and SCRs. Price is from \$10 to \$26, depending on quantity and configuration.

Westinghouse Electric Corp., Westinghouse Bldg., Gateway Center, Pittsburgh, Pa. 15222 [416]

Dual translator links ECL with MOS devices

A semiconductor interface device, the MC10127L dual translator, is designed to link MECL 10,000 levels with MOS logic and memory devices using 10- to 20-volt dc power supplies. Each translator has differ-

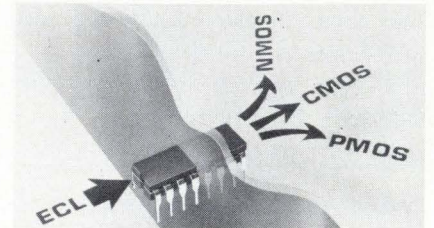

ential inputs, facilitating the use of high-noise-immunity balanced lines and an output capable of driving n-MOS, C-MOS, and p-MOS loads. Propagation delay is typically about 20 nanoseconds. Price ranges from \$7.97 to \$9.96, depending on quantity.

Motorola Semiconductor Products Inc., Box 20924, Phoenix, Ariz. 85036 [417]

Phase-locked loop is designed on a chip

For designers requiring precise frequency synthesis, a phase-locked loop on a chip, designated the SL650C, contains a current-controlled oscillator, a phase comparator, a two-bit binary interfacing circuit, and an auxiliary amplifier. The device, which is especially suited for

9 db

DIRECTIONAL COUPLER
MODEL CH-134

- 10-500 MHz Frequency Range
- Coupling Within $\pm 0.5\text{dB}$
- Ultra-Low Profile—
Only 0.125" High
- \$55/Stock Availability

anzac
ELECTRONICS

39 Green Street, Waltham, Mass.
(617) 899-1900 • TWX 710-324-6484

30-CPS

only 22 lbs.

APL portable?

Yes. And now.
From CDI.

COMPUTER DEVICES INC.
9 Ray Avenue
Burlington, Mass. 01803
Tel. (617) 273-1550

a **TECHVEN**
Corporate Partner

Distributors

Arizona: Hamilton/Avnet,
Phoenix (602) 275-7851
Kierulff, Phoenix
(602) 273-7331

California: Hamilton/Avnet,
Mountain View
(415) 961-7000
San Diego (714) 279-2421
Hamilton Electro,
Culver City (213) 559-4111
Kierulff, Palo Alto
(415) 968-6292
San Diego (714) 278-2112
Wesco Electronics,
Los Angeles (213) 685-9525

Colorado: Hamilton/Avnet,
Denver (303) 534-1212
Kierulff, Denver
(303) 343-7090

Connecticut:
Arrow Electronics
Hamden (203) 248-3801
Hamilton/Avnet
Georgetown (203) 762-0361

Florida: Hamilton/Avnet,
Hollywood (305) 925-5401
Georgia: Hamilton/Avnet,
Norcross (404) 448-0800

Illinois: Allied, Chicago
(312) 421-2400
Hamilton/Avnet, Schiller
Park (Chicago)
(312) 678-6282

Kierulff, Rosemont
(Chicago) (312) 678-8560

Kansas: Hamilton/Avnet,
Lenexa
(913) 888-8900

Maryland: Hamilton/Avnet,
Friendship Int'l Airport
(Baltimore)
(301) 796-5000
Pioneer/Washington
Rockville
(301) 424-3300

Massachusetts:
Gerber, Dedham
(617) 329-2400
Hamilton/Avnet, Burlington
(617) 273-2120
Kierulff, Needham Heights
(617) 449-3600
Wilshire Electronics
Cambridge (617) 491-3300

Michigan: Hamilton/Avnet,
Livonia (313) 522-4700

Minnesota: Hamilton/Avnet,
Minneapolis
(612) 941-3801

Missouri: Hamilton/Avnet,
Hazelwood (St. Louis)
(314) 731-1144

New Jersey: Arrow,
Moorestown (609) 235-1900
Hamilton/Avnet, Mt. Laurel
(609) 234-2133
Cedar Grove (201) 239-0800

New Mexico:
Century, Albuquerque
(505) 265-7837

Hamilton/Avnet
Albuquerque
(505) 765-1500
Kierulff, Albuquerque
(505) 247-1055

New York: Semiconductor
Concepts, Hauppauge
(516) 273-1234

Hamilton/Avnet, Syracuse
(315) 437-2642

Westbury, L.I.
(516) 333-5800

Arrow, Farmingdale
(516) 694-6800

Summit, Buffalo
(716) 884-3450

North Carolina:
Pioneer/Carolina
Greensboro (919) 273-4441

Ohio: Arrow, Dayton
(513) 253-9176

Hamilton/Avnet
Dayton (513) 433-4055

Texas: Hamilton/Avnet,
Dallas (214) 661-8661
Houston (713) 526-4661
Kierulff, Garland (Dallas)
(214) 271-2471

Utah: Hamilton/Avnet,
Salt Lake City (801) 262-8451

Washington:
Hamilton/Avnet,
Bellevue (206) 746-8750
Kierulff, Seattle
(206) 763-1550

Canada: Prelco, Montreal
(514) 389-8051

Ottawa (613) 237-6150
Electro Sonic Ind. Sales,
Toronto (416) 924-9301

Hamilton/Avnet, Montreal
(514) 735-6393
Mississauga (416) 677-7432

Ottawa (613) 725-3071
Varah's, Vancouver, B.C.
(604) 873-3211

Future Electronics
Montreal (514) 735-5775
Ottawa (613) 232-7757
Toronto (416) 677-7820

ANOTHER INNOVATION FROM LITRONIX

THE IRRESISTIBLE LEDS



Our new Red-Lit C200 series constant brightness LED lamps are irresistible because they eliminate the need for external current limiting resistors — saving you time, space and money.

We've accomplished this by packaging a bipolar current regulating IC with the LED. This provides a constant current supply to the LED chip, ensuring a constant brightness over a supply range of 4.5 to 12.5 volts. In addition, the combination of the IC and the LED saves you both board area and

additional component costs. And because there's no need for individual drive circuits, your circuit design job is simplified. This all means that the Bright Guys have come up with another industry first. (Sometimes we feel we're pretty irresistible ourselves.)

There's an irresistible choice of package styles, too. The RLC-200 and RLC-201 are T 1 3/4 size lamps for panel mounting. They're only 50¢ in 1K quantities. The RLC-210 comes in a miniature T 1 size for small tight spaces. And it's priced at 60¢ in 1K quantities.

Want more information on our irresistible LEDs? Call or write the Bright Guys.

the bright guys

litronix

Litronix, Inc. • 19000 Homestead Road • Cupertino, California 95014 • (408) 257-7910 TWX: 910-338-0022
European Headquarters: Litronix, Inc. • Bevan House, Bancroft Court
Hitchin, Hertfordshire SG5 1LW England • Tel: Hitchin 2676 Telex: 825 497

Here's the BEST probe-readout DMM for fast and accurate measurements.

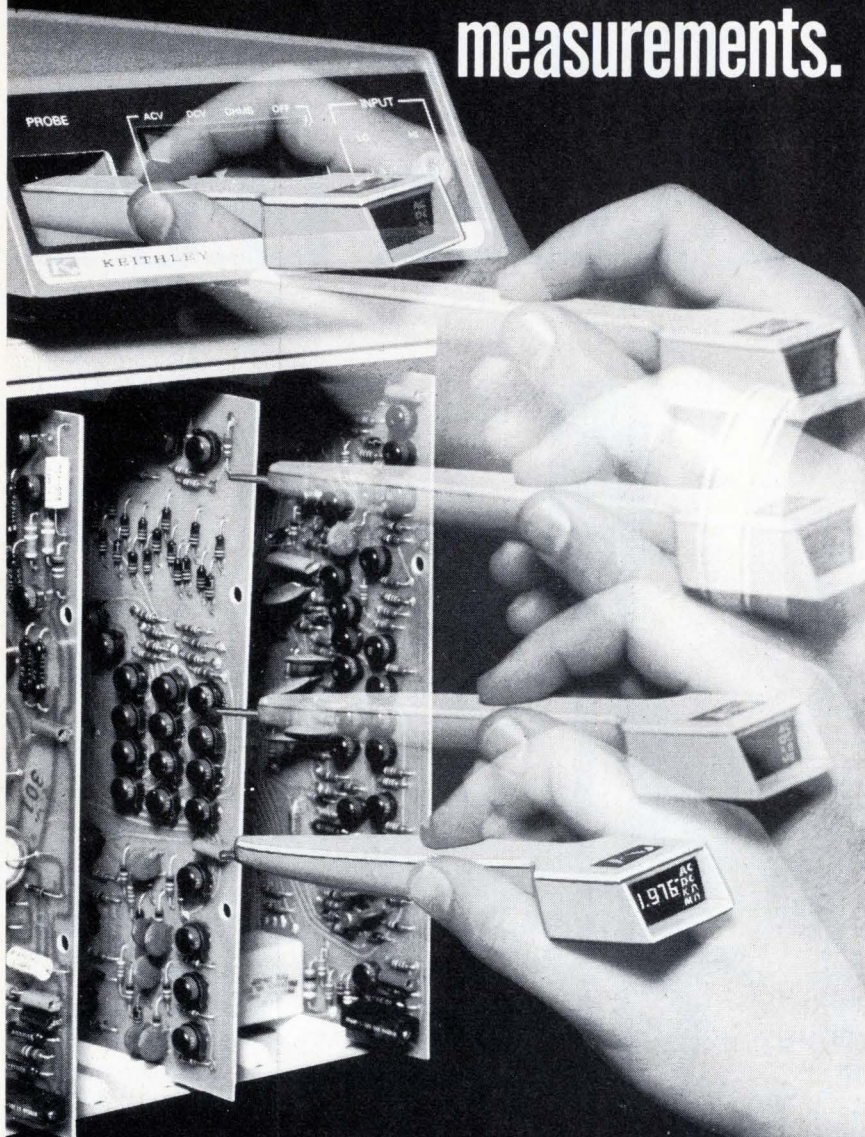

Keithley's Model 167 Auto-Probe DMM is *still* unmatched. We've kept the probe small... not the performance. Look at the features you can't get elsewhere in a probe-readout DMM:

- accuracy to 0.2% dc, 1% ac
- 55 megohms input resistance
- 5 readings (and range-changes) per second
- 20 Hz to 20 kHz ac bandwidth
- 20-hour continuous battery life

Of course, the Model 167 is autoranging...and overload-protected...and it can be line operated too.

The Model 167 Auto-Probe DMM — only \$325. Send for more details. You should have the best.



**KEITHLEY
INSTRUMENTS**
U.S.A. 28775 AURORA ROAD, CLEVELAND, OHIO 44139
EUROPE 14, AVENUE VILLARDIN, 1009 PULLY, SUISSE

New products

use in data modems, permits all common modulation functions. It can also be used for demodulation, signal conditioning, and low-frequency synthesis. Price is \$17.60.

Plessey Semiconductors, 1674 McGaw Ave., Santa Ana, Calif. 92705 [418]

Multiphotocoupler provides higher circuit density

A multiphotocoupler that combines four lamp cells in the one package is designed so that higher than conventional circuit-board density is possible. The optoelectronic unit

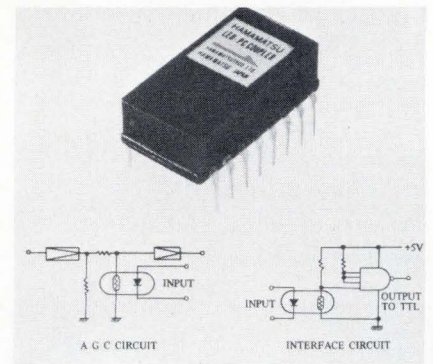

consists of a light-emitting diode and photoconductive elements molded into a DIP. Price is \$6.25.

Hamamatsu Corp., 120 Wood Ave., Middlesex, N.J. 08846 [419]

Power Darlington devices aimed at automotive uses

A line of six power Darlington transistors is designed primarily for automotive-electronics applications. The units are essentially dual-transistor devices in a single chip that incorporates integrated load resistors. They are especially useful in systems that require high gain characteristics. The six devices consist of three transistor types packaged in TO-3 metal cans and three electrically equivalent devices in TO-220 plastic power packages. Price ranges from 81 cents to \$1.95 each, depending on type and quantity.

Fairchild Camera & Instrument Corp., 464 Ellis St., Mountain View, Calif. 94042 [420]

ALPAC® ... A Semtech Original!

There are a lot of rectifier assemblies that look like ALPAC. But only the original ALPAC (a Semtech trademark) has a time-tested proven design.

ALPAC, short for aluminum package, features insulated terminals and rugged terminal/rectifier construction.

Introduced by Semtech more than 10 years ago, ALPAC continues to give the industry a new packaging concept offering increased reliability while lowering equipment production costs.

ALPAC is the only series of component assemblies that utilizes the "state-of-the-art" Metoxilite hermetically sealed rectifier — the silicon rectifier with more NASA and MIL approvals than any other device manufactured today.

Internal components are supported in a low thermal impedance, epoxy thermoset-filled high alumina ceramic. This construction firmly secures and insulates the internal components to temperatures above 300°C. Don't specify a "look alike" specify ALPAC, the original!

NOTE: "Fast Recovery" available in all ALPAC types.

ALPAC ... The industry standard!

The first ALPAC bridge rectifier on the market, has a proven record in such applications as power supplies, AC to DC converters and motor controls. Designed to eliminate stud rectifier packaging problems. Available in medium and fast recovery with PIV of 50 to 600V and average rectified current of 25A at 55°C case temperature (20A for fast recovery devices). Size 1.125 x 1.125 x 1.0 inches. Also available are doubler and center taps.



ALPAC Jr. ... The big little package!



Even though this multipurpose device features a small case (.75x.75x.50 inches), it can handle an average rectified current of 5A at 55°C case temperature. Single cycle surge rating of 50A and available in PIV from 50 to 600V.

ALPAC Sr. ... For the big jobs!

When you need an average rectified current of 150 to 250A with PIV from 50 to 600V, look to ALPAC Sr. They can handle the load. Available in full wave, three phase full wave and three phase half wave bridges, doublers and center taps.

ALPAC - 3 ... Phase three!



A logical extension to our original ALPAC is a three phase, full wave bridge rectifier. Average rectified current rating at 55°C case temperature is 25A, PIV from 50 to 600V, single cycle surge 150A. Size 2.25x.80x.75 inches.

New ALPAC-3 Jr. ... The smallest three phase!



A three phase full wave rectifier, measuring only 1.25x.45x.40 inches. The device has a low profile. Although small, ALPAC-3 Jr. will handle an average rectified current of 5A at 55°C case temperature, PIV of 50 to 600V, and a single cycle surge current of 50A.

New ALPAC3-"T" ... The thin one!



A small three phase full wave rectifier, measuring .75x 1.25x .40 inches, capable of supplying an average rectified current of 10A at 55°C case temperature. Single cycle surge rating of 150A, available in PIV from 50- 600V.

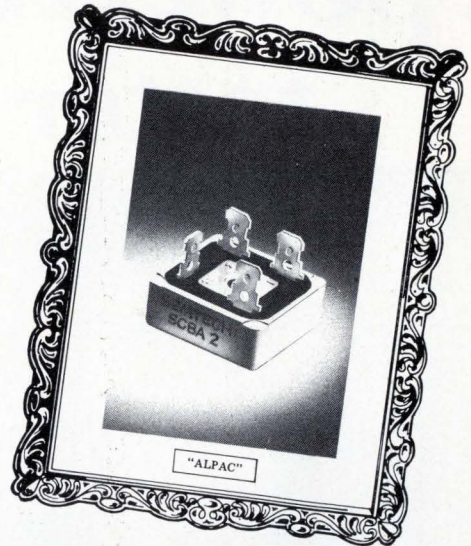

ALPAC 50 ... Nice to have a-round!

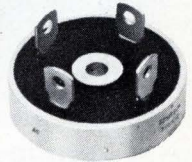

A complete line of single phase full wave silicon bridge rectifiers available in the ALPAC 50 round (2 inch dia. x 1.0 inch high) package. Average rectified current of 50A @ 75°C case temperature, single cycle surge 375A, PIV from 50 to 1000V.

New ALPAC R 50 ... With corners!



Available in single phase and three phase full wave bridge assemblies. Measuring only 1.0x2.0x1.1 inches, a solution to stud rectifier packaging problems. Rated to handle 50A at 55°C case temperature. PIV from 50 to 600V. Single cycle surge current is 375A.

"We're number 1 because we try harder"



652 Mitchell Road, Newbury Park, California 91320
(805) 498-2111, (213) 628-5392 / TWX: 910-336-1264

CHICAGO: (312) 352-3227
DALLAS: (214) 253-7644
FLORIDA: (305) 644-5404
NEW JERSEY: (201) 654-4884
SAN FRANCISCO: (415) 328-8025
EUROPEAN SALES: (Switzerland) (042) 323-242

® ALPAC IS A REGISTERED TRADEMARK OF THE SEMTECH CORPORATION.

Now, a powerful computerized tester in a suitcase

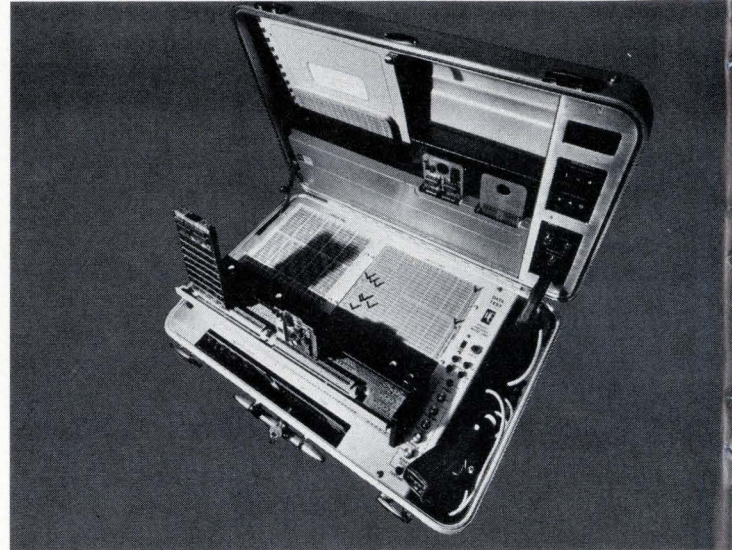

Isolate system faults quickly and easily with this new computerized suitcase tester... in the plant, in the field, on the user's site.

The Datatester 2400 is the most flexible . . . most powerful . . . easiest to operate portable tester available anywhere.

It's almost like having a large, expensive, computer-based test system you can carry with you.

But it will do more than any tester you've seen to date.

And it's priced at less than \$7,000, so you can buy the Datatester 2400 by the gross.

Testing systems/subsystems . . .

The Datatester 2400 is the first test unit that helps you locate system faults. Instead of guessing what's at fault—the CPU, controller, or peripheral—use the 2400 for on-line simulation and check the CPU. Or exercise the controller and peripheral off-line to quickly run down the problem.

Testing subsystems/units . . . Okay, now that you know what subsystem is at fault, you can zero in further. Simulate the processor and peripheral to check the controller I/O, timing, read/write, I/O bus, or peripheral interface. They're all easy with the powerful echo timing and halt/wait controls built into the 2400. Continuous test recycling lets you do printing or mechanical adjustments with ease. Driving peripherals of

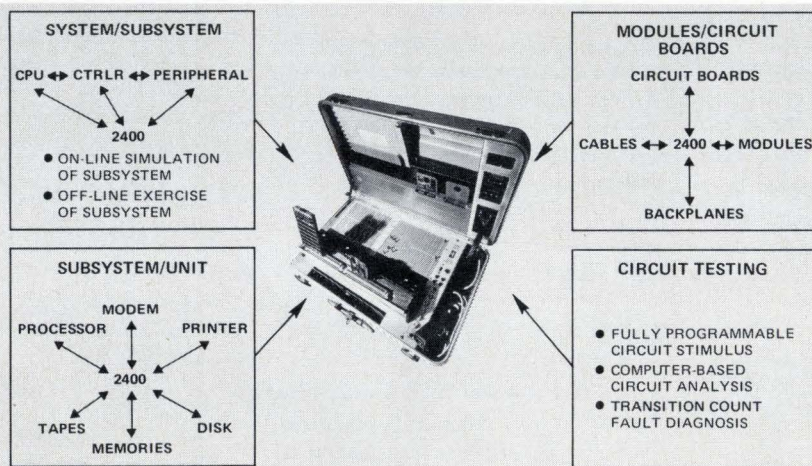

Testing modules/circuit boards . . .

Once you've located the unit that has the problem, you can perform module/circuit board testing to locate which portion of the unit has the fault. The Datatester 2400 lets you perform complete module or circuit board testing as well as cable, memory, and backplane testing.

Testing circuits . . .

Because of the power housed in the suitcase of the Datatester 2400, either computer-based

all types for complete off-line testing is a snap with the 2400. Think of the savings in CPU and line time alone.

analysis or the TRANSITION COUNT fault diagnostic probe will lead you directly to the faulty components. You'll be able to test all types of devices, including TTL, DTL, MOS, CMOS, MOS-LSI, with either synchronous or asynchronous logic. This includes common port systems.

For more information on the Model 2400, ask the people who think about your testing problems for the life of your product. Contact Data Test Corporation, 2450 Whitman Road, Concord, California 94518, (415) 689-3583.



DATA TEST CORPORATION

Subassemblies

A-d unit offers 12-bit accuracy

Nichrome-nickel-gold thin-film resistor network is laser-trimmed

Thin-film hybrid technology is steadily winning more friends among converter manufacturers—this past year, Analog Devices, Hybrid Systems, and Burr-Brown all bought thin-film facilities. Micro Networks Corp. of Worcester, Mass., however, has had a thin-film capability since its founding in 1969, and it is now introducing a new thin-film hybrid 12-bit analog-to-digital converter series, the MN5200.

The 1.3- by 0.8- by 0.15-inch unit comes in a 24-pin hermetically sealed dual in-line package, and the company claims it provides full 12-bit accuracy and linearity, without external adjustments, over the entire operating temperature range.

Largely responsible for this performance is a laser-trimmed resistor

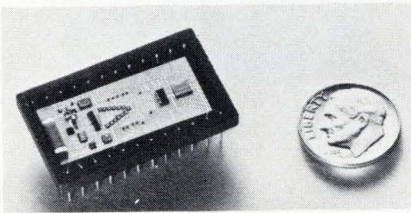

network with an accuracy to within $\pm 0.01\%$. The layers of nichrome, nickel, and gold, of which the resistors are made, give them high temperature-stability. (Nichrome is stable through 125°C and typically has an absolute temperature coefficient of ± 25 parts per million.) The resistors are all laid down in one process and then are functionally trimmed with a laser after the entire circuit has been assembled, resulting in a uniformity that Micro Networks president Robert R. Jay says "you just can't get otherwise." After trimming, he claims, the 5200 has temperature-coefficient tracking of 1

ppm, considerably less than the 10–20 ppm typical of thick-film resistors.

The thin-film-hybrid approach also reduces current leakage in the unit's digital-to-analog circuitry, the company says. In a high-resolution d-a converter, signals are measured in microamperes. With ICs, up to a quarter or half of a least significant bit can be lost at room temperature, while at high temperatures above 100°C , errors can be very significant. Micro Networks, however, uses transistor switches with tightly matched base-emitter-voltage drops, and the functional laser-trimming compensates for temperature differences among the switches.

The small size also offers several advantages over conventional modular a-d converters, Micro Networks believes. The 5200 takes up less board space, with its 600-mil pin centers. It can be tested in standard IC sockets, and, says Jay, it performs better because closely packed circuits have more uniform temperatures and shorter signal paths.

The 5200 has a 40-microsecond conversion time and an operating temperature range of 0 to 70°C . Also in production is the 5200H, which meets full military temperature specs with a range of -55° to $+125^\circ\text{C}$. Work is also being done on units with a 20-microsecond conversion time.

Linearity of all units in the series is half a least significant bit; full-scale error at 25°C is 0.02% ; and full-scale error from 0 to 70°C , 0.4% . Slew rate is 0.5 volt per microsecond, and pulse width is 100 milliseconds.

Price of the 5200 is \$225 for 1–24 units; of the 200H, \$395.

Micro Networks Corp., 5 Niagara Lane, Worcester, Mass. 01604 [381]

Sample-hold memory has 30-ns acquisition time

The model 5024 sample-and-hold memory is designed for use with the OEI model 7530 analog-to-digital converter, but is useful in any system having a 5-volt full-scale-volt-

age level and a 10-megahertz cycle time or repetition rate. Maximum acquisition time is specified at 30 nanoseconds, and slewing rate is ± 600 volts per microsecond. Price ranges from \$179 to \$221, depending on quantity.

Optical Electronics Inc., Box 11140, Tucson, Ariz. 85706 [386]

Tiny modular ac-dc supply puts out 3 to 24 volts

A small modular ac-dc power supply is designed to power integrated circuits and discrete component assemblies. The devices measure 1.7

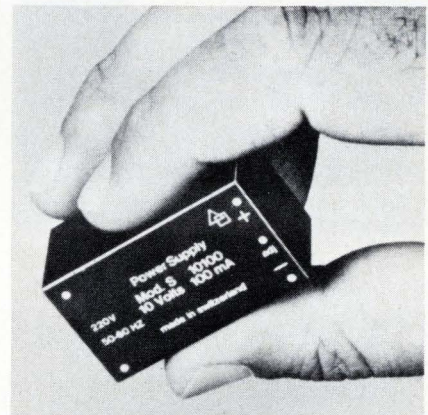

by 1 by 0.85 inch and have an input of 220 volts ac or 110 v ac. Output ranges from 3 to 24 v and from 50 to 140 milliamperes. Each power supply is a complete unit with no additional external components required. Input isolation is $2,000$ v.

EEP Corp., 10180 W. Jefferson Blvd., Culver City, Calif. 90230 [383]

Dc-to-dc converter translates 5 volts to ± 30 v

Called the 4000 series, a dc-to-dc converter translates $+5$ volts to any desired voltage from -30 to $+30$ v with a maximum output power of 10 watts. The converter is built on a 2-by-2-inch printed-circuit board, or it can be made to customer specifications. In this way, it can take the $+5$ v from the existing backboard and convert it to different voltages,

30-CPS



only 22 lbs.

MULTICS portable?

Yes. And now.
From CDI.



**COMPUTER
DEVICES INC.**

9 Ray Avenue
Burlington, Mass. 01803
Tel. (617) 273-1550

a **TECHVEN**
Corporate Partner

Circle 150 on reader service card

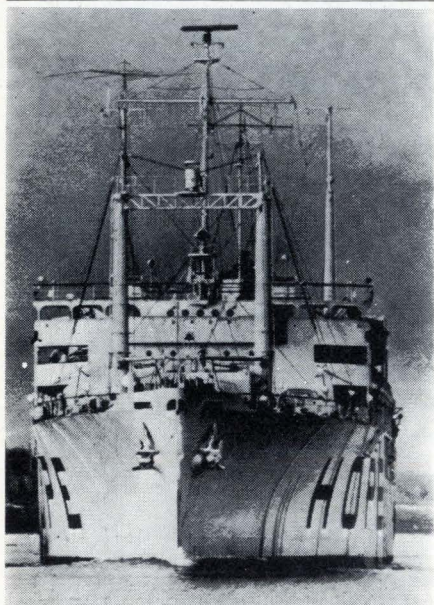

S.S. HOPE, M.D.

Doctor . . . teacher . . . friend to millions on four continents—this floating hospital is a symbol of America's concern for the world's disadvantaged. Keep HOPE sailing.

**PROJECT
HOPE**

Dept. A, Washington, D.C. 20007

New products

returning into a different pin of the user's connector. Price starts at \$20. Integrated Memories Inc., 495 Andover Industrial Center, Andover, Mass. 01810 [387]

Programmable active filters cover 0.1 Hz to 50 kHz

The 744 series of active filters are BCD programable four-pole low-pass types, with cut-off frequencies variable in 500 equal increments over a 500:1 range. They are offered with either a Butterworth or Bessel

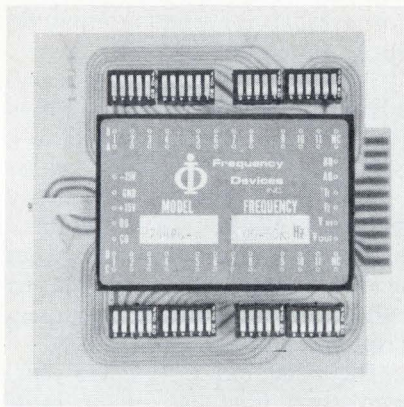

response characteristic. Four basic models cover the range from 0.1 hertz to 50 kilohertz, with maximum cutoff frequencies of 50 and 500 Hz and 5 and 50 kHz.

Frequency Devices Inc., 25 Locust St., Haverhill, Mass. 01830 [384]

Voltage-frequency converter aimed at digital transmission

A line of voltage-to-frequency converters that produce output pulse trains with a frequencies that are directly proportional to the analog input signals includes the model VFC-100K with output frequencies of 0 to 100,000 Hz, and the model VFC-10K with output frequencies of 0 to 10,000 Hz. The wide dynamic output range of up to six decades makes the modules ideal for use in digital transmission systems employing pulse-position modulation and frequency-shifting techniques. Other applications include phase-

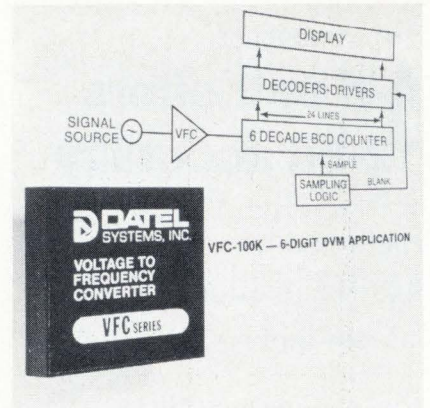

locked loops. Price is \$89 for the model 10K and \$109 for the 100K. Datel Systems Inc., 1020 Turnpike St., Canton, Mass. 02021 [385]

Display requires only 10 mW of power

Electroluminescent readouts with digits measuring 1/2-inch high cost only 50 cents per digit in production quantities. The readouts are available with a variety of connectors: card-type, socketed, and soldered. Other digit heights are available in

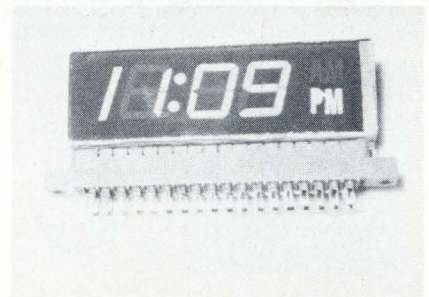

heights from 3/8 in. to 12 in. in blue or green. Power requirement is low; for example, the 1/2-inch digits require only 10 milliwatts. Tau Electronic Products Inc., Emporium, Pa. 15834 [388]

Sine-wave oscillator is stable to ±0.25%

Offering an amplitude stability of ±0.25% from 0 to +50°C, a sine-wave crystal oscillator is adjustable up to 5 volts rms into a 10-kilohm

yes,
yes,
no,
yes,
no.

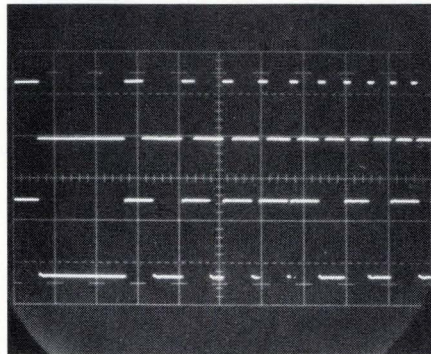

Upper trace: Constant Duty Cycle pulses over a 10:1 frequency range.
Lower trace: Normal pulses over same range.

"Standard pulses with predetermined width are fine for most requirements, but when I'm changing repetition rates I have to fiddle with the width control to make sure that I don't lose the pulse. Does your 'Constant Duty Cycle' mode let me set width as a percent of pulse period so I can change rep rates *without* tweaking the other controls?" (YES)

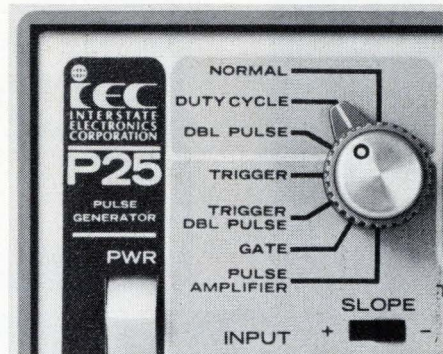

A single control selects all 7 modes.

"That Duty Cycle mode could come in handy, but I also want the regular pulses that I'm used to, and double pulses, and 50% squarewaves to 50 MHz. How about trigger, gate, triggered double pulse, and pulse shaping? (And all of these modes better be easy to set!)" (YES)

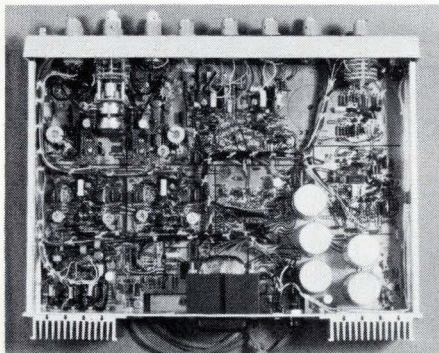

All components are fully accessible.

"Reliability and maintainability count, too. I want a generator that works! But in case it needs service I'd like to specify plug-in sockets for dual in-line IC's, and a parts list minus factory wickets. If I put my money on your model, will my QC man hate me?" (NO)

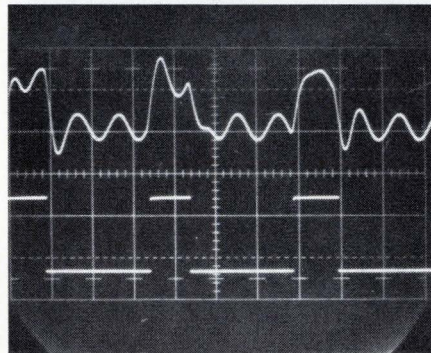

Upper trace: distorted, noisy input.
Lower trace: pulse generator output (Pulse Amplifier Mode).

"My application calls for pure pulses with a bare minimum of overshoot and squiggles. And I need to clean up distorted signals — you know, send in a crummy pulse train and get out a nice squared-up pulse with the offset, amplitude, and rise/fall times I've set up on the generator. Can do?" (YES)

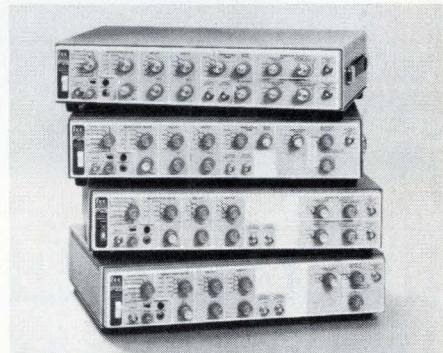

Four SERIES 20 models are available from \$575.

"Your \$1095 P25 Pulse Generator has it all, including simultaneous positive and negative outputs, each with adjustable d-c offset and variable rise/fall times from 5 nanoseconds. But if I only need a single output or faster, fixed rise times, am I out of luck?" (NO)

ask a 50-MHz pulse generator these 5 questions
if the answers are yes, yes, no, yes, no,
it's INTERSTATE

the Interstate man with all the answers is John Norburg — call collect (714) 772-2811



INTERSTATE ELECTRONICS CORPORATION
Subsidiary of A-T-O Inc.

U.S. HEADQUARTERS: Dept. 7000, Box 3117, Anaheim, CA. 92803; OVERSEAS SALES OFFICES: AUSTRALIA, Parameters Pty., Ltd.; BELGIUM-LUXEMBOURG, Regulation-Mesure S.P.R.L.; FINLAND, Havulinno Oy; FRANCE, Tekelec Airtronic, S.A.; ITALY, Tekelec Airtronic; ISRAEL, Radat International Company Ltd.; JAPAN, Asahi & Co., Ltd.; NETHERLANDS, Tekelec Airtronic, N.V.; NEW ZEALAND, David J. Reid, Ltd.; REPUBLIC OF CHINA, Bons International Co., Ltd.; SPAIN, Telco, S.L.; SWEDEN, M. Stenhardt AB.; SWITZERLAND, Traco Trading Co., Ltd.; UNITED KINGDOM, Euro Electronic Instruments, Ltd.; WEST GERMANY, Tekelec Airtronic GMBH; CANADA, Radionics, Limited. TWX U.S.A. 910-591-1197 TELEX U.S.A. 655443 & 655419

ENERGY SHORTAGE ?



HARNESS THE POWER OF THE **adam**

You've only got so much time and energy to spend breadboarding and testing new circuit designs.

Adam gives you, in one compact portable package, everything you need to go from circuit concept to working hardware in 1/3 the time (and energy!) of ordinary breadboarding methods.

It's a complete, modular circuit design lab with power supplies (five (5) of them!), metering, logic readouts, function and pulse generators, switching, and solderless circuit design using the E&L SK-10 solderless component socket.

Write today for full details.



E&L INSTRUMENTS, INC.

61 First Street, Derby, Conn. 06418
Phone (203) 735-8774 Telex No. 963536

In Canada:

JOHN FORTIN CO., LTD.

221 Academy Road, Winnipeg, Manitoba
Phone (204) 284-5813

Circle 152 on reader service card

HAVE MINICOMPUTER? NEED MAG TAPE?



NOVA PDP-8 PDP-11

Tell us what kind of mini you have and we'll send the details, along with our new short-form catalog describing our complete line of synchronous, incremental and low power tape units from \$2000.



DIGI-DATA CORPORATION

4315 Baltimore Ave., Bladensburg, Md. 20710 • (301) 277-9378

How many tape drive manufacturers with over ten years' experience supply transports and mini-computer interfaces starting at \$4525 in single quantities? Digi-Data does . . . and offers generous OEM discounts besides. We're delivering both NRZI and 1600 BPI PE systems furnished with diagnostics and fully burned in on our own minicomputers . . . all transport sizes, and speeds to 45 ips.

152 Circle 174 on reader service card

New products

load. The oscillator also offers a total harmonic distortion of less than 1%, available at any fixed frequency from 100 hertz to 400 kilohertz, with

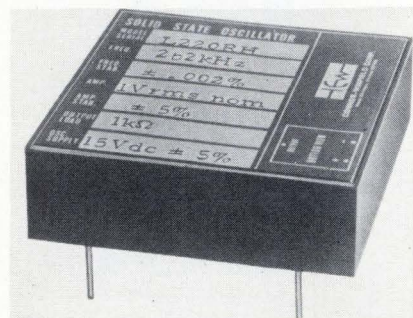

a frequency adjustment of ± 100 ppm. Unit price ranges from \$100 to \$250.

Connor-Winfield Corp., W. Chicago, Ill. 60185 [389]

Signal-conditioning amplifier offers low noise, ruggedness

A signal-conditioning amplifier, the model NCA150, is a ruggedized unit that offers fully isolated input/output power and operates over the ambient temperature range from -60 to $+212^{\circ}\text{F}$. The unit,



which accepts low-level inputs from thermocouples, strain gages, and other devices, has outputs of 0 to 1, 0 to 5, or 0 to 10 v dc. An internal thermocouple-reference junction is accurate to within 0.25°C . The unit offers small size, light weight, and low noise.

Hades Manufacturing Corp., 151A Verdi St., Farmingdale, N.Y. 11735 [390]

Electronics/January 24, 1974

How much do your "free" magazines cost you?

Free electronics magazines come flying across your desk month after month. But have you ever stopped to figure what these giveaways actually cost you?

Time is money, and you can spend a pile of it plowing through "free" publications looking for the information you need.

ELECTRONICS is different. It has the manpower and the expertise to edit out what's inconsequential and to hone down what is important so that you can get to the heart of the subject matter quickly. The result: you cut hours off your reading time.

In ELECTRONICS, you get *all* you need to know in a fraction of the time it takes you to wade through any free magazine. Every

issue of ELECTRONICS is packed from cover to cover with up-to-date information, the breaking news of the ETM-Electronics Technology Marketplace in the U.S. and worldwide.

ELECTRONICS tells it faster, cleaner and straight to the point. Every time.

Isn't it worth 8 dollars a year to make sure you stay on top of what's happening in the Electronics Technology Marketplace? Only one magazine stays on top—ELECTRONICS. ELECTRONICS is the Source.

And you can get ELECTRONICS where you can find the time to read it—at home. Go to *the Source*, today. Just fill out the subscription card enclosed in this issue, and send it off.

Electronics 
IS THE SOURCE. 



A world free from early heart attack
and stroke.

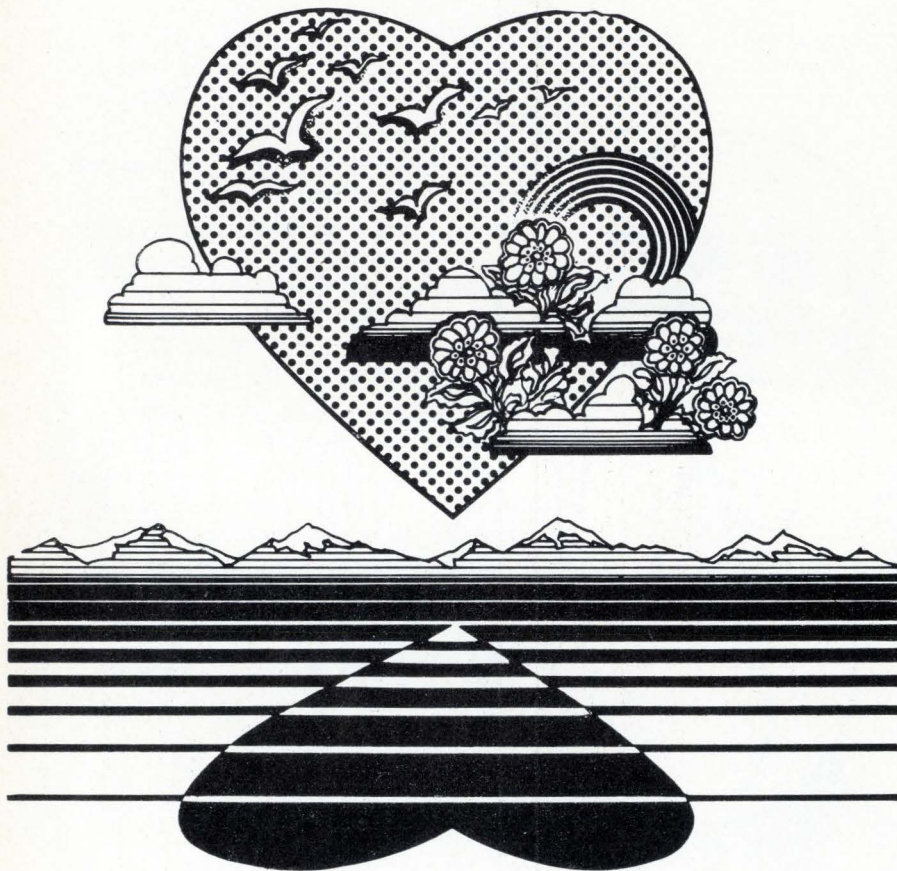

That's what we're all about.

Ask your
Heart Association



Give Heart Fund

New literature

Computer plan. A 12-page brochure from Prime Computer Inc., 17 Strathmore Rd., Natick, Mass. 01760, describes the company's computer-user plan, designed to simplify the application of the company's products, especially as applications change. The booklet explains how the plan is applied to buying, using, and upgrading the line of small and medium-scale computers. Circle 421 on reader-service card.

Processor. Floating Point Systems Inc., Portland, Ore., has issued a 24-page programming manual on model FP-07 Nova processors and Data Control Corp. D-116 mini-computers. [422]

Storage unit. A data sheet describing several applications of the model 1300A electronic storage unit is available from Plantronics Inc., Santa Clara, Calif. The basic unit provides storage of 2,560 characters and is expandable to 20,480 characters with additional plug-in sections. [423]

Thermistors. Victory Engineering Corp., Victory Rd., Springfield, N.J., has published a specifications bulletin for the company's line of positive-temperature-coefficient thermistors. It includes dimensional drawings, temperature and resistance curves, electrical specifications, and applications notes. [424]

Line printer. A bulletin from Custer Research Inc., Box 305, Fleetwood, Pa. 18522, provides information on the S2531 line-printer subsystem. [425]

Magnetic shields. Ad-Vance Magnetics Inc., 226 E. Seventh St., Rochester, Ind. A two-page data sheet answers the problem of how to economically design magnetic shields that will remain in place on small motors. [426]

Bar solder. A brochure from Refinery for Electronics Inc., Jersey Ave., Jersey City, N.J. 07302, discusses the various aspects of using bar solders in the electronics industry. In-

PUBLI-SERVICE

SALON INTERNATIONAL DES

**composants
électroniques**

PARIS 1-6 / 4 / 74

COMPONENTS - MEASURING
MATERIALS - EQUIPMENT

Organisation S.D.S.A. - 14, rue de Presles 75740 Paris Cedex 15

FRENCH TRADE SHOWS 1350 Avenue of The Americas
NEW YORK, N.Y. 10019 Tel.: (212) 582-4960, 1

DIACON'S AUTOMATIC ENVIRONMENTAL STORAGE HANDLER:

- 200 DEVICES IN 029 CARRIERS
- RELIABLE • SIMPLE
- EASY TO MAINTAIN

Fewer moving parts inside the environment (two bushings only) provide long, maintenance-free operation. The Diacon storage handler is quiet and mechanically uncomplicated. Which helps eliminate down-time. Operates on 120 or 240 V.

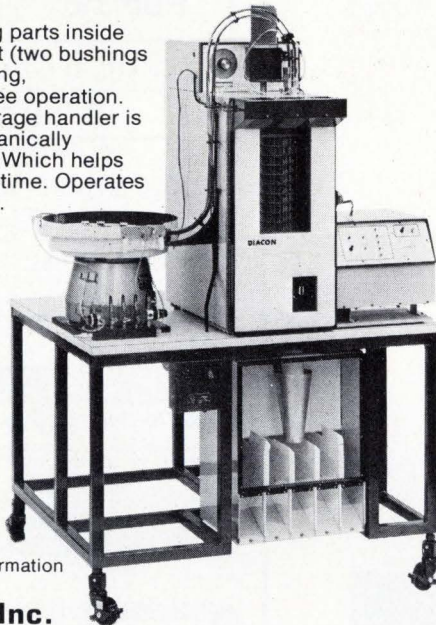

For complete information and specs, write:

DIACON, Inc.
4812 Kearny Mesa Rd.
San Diego, Calif. U.S.A.
(714) 279-6992.

Circle 176 on reader service card

The Brush recorder module. It gives your system the competitive edge.

OEM recorder modules give you design flexibility along with all the Brush exclusives.

Choose single or dual channel, low profile or vertical models. There's a wide range of chart speed options.

Plus Brush exclusives like pressurized ink writing and Metrisite® servo loop feedback system that assures 99.5% linearity.

Write Gould Inc., Instrument Systems Division, 3631 Perkins Avenue, Cleveland, Ohio 44114. Or Kouterveldstraat Z/N, B 1920 Diegem, Belgium.

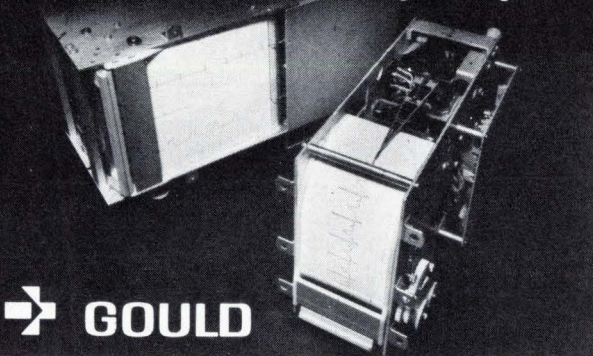

GOULD

Circle 177 on reader service card

The long-billed heat sucker would like you to meet her family.

Our good friend, the Heat Sucker (better known as a Hughes heat pipe), is now the proud mother of an entire flock: round and flat bills, flexible round bills and the cold mounted plate bill. Each variant feels right at home in electronic, chemical and mechanical equipment; industrial processing; and medical applications. Anywhere you might need thermal control.

Heat Suckers come in various sizes: 3/16" to 1" diameter, 6" and 12" lengths. They have thermal transport capabilities of 10 to 2,000 watts covering temperature ranges from: -90°C to +200°C.

Since the birds have mass migrated to our shelves, you can order right off the shelf for as little as \$37.00 (less in quantity).

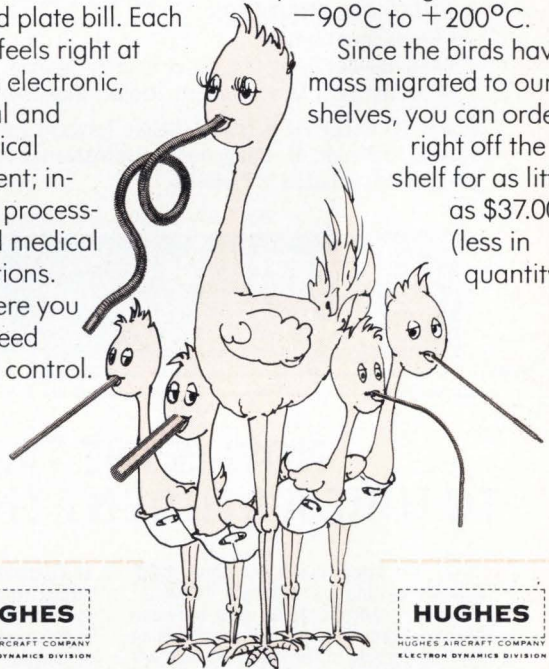

HUGHES

HUGHES AIRCRAFT COMPANY
ELECTRON DYNAMICS DIVISION

HUGHES

HUGHES AIRCRAFT COMPANY
ELECTRON DYNAMICS DIVISION

Celebrate along with us. Send the coupon and get a cigar and literature. Hughes Electron Dynamics Division, Advertising Dept., 3100 W. Lomita Blvd., Torrance, California 90509. Or call (213) 534-2121, Ext. 451.



1350H Series —
stainless steel
and methanol.



1370H Series —
copper and water.



1333H —
stainless steel
and ammonia.



Custom
Designs —
flexible, flat, and base plates.

Name _____

Company _____

Address _____

City _____ State _____

Zip _____ Telephone _____

E 1

Circle 155 on reader service card 155

ELECTRONIC ENGINEERS

Hamilton Standard will bring out the best in you. . .

There's an air of achievement within our busy, modern Electronic Systems and Space Systems Departments. Products include controls for both avionic and industrial applications, advanced electronic and electromechanical control systems, special instrumentation, automotive diagnostic check-out equipment, and guidance and control systems. Engineering activities employ the latest analog, digital and hybrid control techniques. Our products have wide acceptance in aviation, aerospace and industrial applications.

WE ARE SEEKING ELECTRONIC ENGINEERS WITH 1 TO 5 YEARS EXPERIENCE AS:

- Circuit Design, and Product Test and Development, Analog and Digital.
- Test, Instrumentation, Project Engineering.
- Systems Design.
- Analytical Engineers (Scientific Programmers)

MECHANICAL ENGINEERS

- Component Design.
- Mechanical Designers, Electronic Packaging.
- Product Test/Development, Project Engineering.

PLAN TO INTERVIEW NOW. Please forward your resume, stating present salary, to Mr. R. B. Bilanchone, Professional Placement, Hamilton Standard, Windsor Locks, CT 06096.

An Equal Opportunity Employer m/f



NOW IS THE TIME . . . TO HIRE A STUDENT THIS SUMMER.

First, it's later than you think, with schools closing on different semester schedules, and students torn between lining-up "sure" jobs now or gambling that something in their chosen field will come along later.

Second, and most important, it's in our industry's best interest to encourage and hold its life-blood by providing practical experience in their future profession.

And, since there'll always be more applicants than openings, you'll be able to select the cream of the crop, then

evaluate them with an eye towards hiring, when as coveted graduates, the job market might well be in their favor.

Because we believe this program is of mutual benefit to both employer and employee alike, we again offer our services as a clearing-house.

Just fill out and return the coupon below, and we'll include your organization in a free listing to be sent to Placement Directors and Department Heads at leading colleges and universities across the nation.

Free summer help listing

MAIL TO: ELECTRONICS/POST OFFICE BOX 900/NEW YORK/NY 10020

NAME/TITLE (of individual to be contacted)

ADDRESS: (Mailing address of your personnel office)

ORGANIZATION: (Firm, Company, Government Agency or Institution)

TYPE AND NUMBER OF STUDENTS SOUGHT: Electronics Aerospace

Mechanical Electrical Other Preferences Draftsman, etc.)



1-24-74

IMMEDIATE DELIVERY

Minis & Peripherals

DEC—HIS—NOVA

SEL—HP—MOHAWK

CPU, Card, Printer, Tape, Disk

NEW • MOHAWK 4320 PRINTERS

**PDP 11 PERIPHERALS
CPU, MEMORY**

PDP 8 CPU \$1500

\$750 Minis

TELETYPE 35 & 37

DEC & HONEYWELL Modules

617/261-1100

Send for Free Report "Maintenance of Computers"

AMERICAN USED COMPUTER CORP.

P.O. Box 68, Kenmore Sta., Boston, MA 02215

member COMPUTER DEALERS ASSOCIATION

CIRCLE 951 ON READER SERVICE CARD

FREE CATALOG

HARD-TO-FIND PRECISION TOOLS

Lists more than 1700 items—pliers, tweezers, wire strippers, vacuum systems, relay tools, optical equipment, tool kits and cases. Also includes four pages of useful "Tool Tips" to aid in tool selection.

JENSEN TOOLS
4117 N. 44th Street, Phoenix, Ariz. 85018

CIRCLE 952 ON READER SERVICE CARD

free catalog

**POTTING APPLICATORS
MANUAL OR AIR OPERATED**

2½cc 6cc 12cc 30cc
FOR POTTING, ENCAPSULATING ETC.

PHILIP FISHMAN CO., INC.
7 CAMERON ST. WELLESLEY, MASS. 02181

CIRCLE 953 ON READER SERVICE CARD

FREE ALARM CATALOG

Full line of professional burglar and fire alarm systems and supplies. 80 pages, 400 items. Off-the shelf delivery, quantity prices.

mountain west alarm
4215 n. 16th st., phoenix, az. 85016

CIRCLE 954 ON READER SERVICE CARD

RADAR SYSTEMS GROUND AND AIRBORNE. AUTOMATIC TRACKING ANTENNA SYSTEMS. NIKE AJAX. NIKE HERCULES M-33. MSQ-1A. MPS-19. MPS-9. SCR 584. TPS-1D. TPS-28. FAA-ASR-2. AIRBORNE SYSTEMS. APN-84. APN-102. APS-20. APS-27. APS-45. DPN-19. DIGITAL COMPUTERS. IBM 650. IBM 704.

LARGEST INVENTORY OF RADAR AND MICROWAVE EQUIPMENT IN THE WORLD.
RADIO RESEARCH INSTRUMENT CO.
3 QUINCY ST., NORWALK, CONN. 06850 (203) 853-2600

CIRCLE 956 ON READER SERVICE CARD

POSITIONS VACANT

Positions Available-Electrical & Electronic Eng's: Over 1000 US client co's pay our fees for selected technical referrals. Est. 1959. Send resume with referral. Atomic Personnel, Inc., Box L, 1518 Walnut St., Phila., Pa. 19102.

Semi Skilled Labor Available on Caribbean Island. No taxes. PW-4531, Electronics.

New literature

formation regarding purity, characteristics, and production performance is given. [427]

Time codes. Chronolog Corp., 2583 W. Chester Pike, Broomall, Pa. 19008, describes the most common types of serial time codes used for recording real or elapsed time on the recording channel or the event-marker channel of oscillographs recording in BCD form. [428]

IC replacement guide. A revised Linear IC Direct Replacement Guide, available from RCA, Solid State Division, Rte. 202, Somerville, N.J., includes solid-state devices manufactured by 13 companies. The new issue, CRG-110A, also reflects the changes in RCA linear-IC type designations. [429]

Microwave components. Technical specifications, product features, and applications are given in a brochure covering more than 4,000 coaxial and waveguide microwave components and subsystems made by Syston-Donner Corp, Microwave Division, 14844 Oxnard St., Van Nuys, Calif. 94086 [430]

Minicomputer guide. Hewlett-Packard Co., 1501 Page Mill Rd., Palo Alto, Calif. 94304. A 56-page guide for the H-P 3000 multiterminal, multilingual minicomputer describes software capabilities and options. [431]

Switches. A 72-page switch and keyboard catalog is being offered by Cherry Electrical Products Corp., Waukegan, Ill. [432]

Coaxial components. More than 100 components and accessories for high-frequency applications to 9 GHz are described in a 32-page catalog from General Radio, 300 Baker Ave., Concord, Mass. 01742 [433]

Digital plotter. Houston Instrument Division, Bausch & Lomb Inc., 4950 Terminal Ave., Bellaire, Texas 77401, has published a four-page brochure describing the company's 36-inch digital plotter for printed-circuit-board applications. [434]

SOCKETS BY AUGAT.[®] PHENOLIC BY PLENCO. A DUAL SUCCESS.

These wire wrap* dual-in-line sockets for testing and packaging integrated circuits and components are produced by Augat Inc., Attleboro, Mass.

Our Plenco 307, a general-purpose phenolic compound of improved impact strength and excellent electrical and physical properties, is used in molding the body of the sockets. The molder: Waterbury Companies, Inc., Waterbury, Conn.

The compound, according to Waterbury, checked out to be "uniform batch to batch, rendering dependable processing characteristics."

Uniformity. Ever a prime objective at Plenco. Achieved in this precision application as in so many other kinds in nearly every industry. Try us.

*Gardner Denver Trade Mark

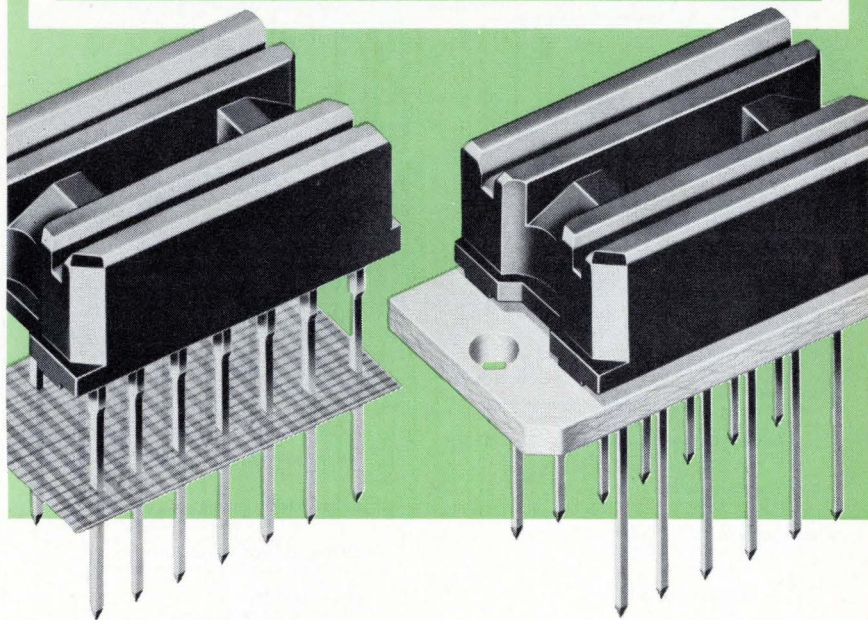

PLENCO
THERMOSET PLASTICS

PLASTICS ENGINEERING COMPANY

Sheboygan, Wis. 53081

Through Plenco research . . . a wide range of ready-made or custom-formulated phenolic, melamine and alkyd thermoset molding compounds. and industrial resins.

Electronics advertisers

January 24, 1974

Abbott Transistor Labs., Inc. Technical Advertising Agency	6	EL Instruments, Inc. Langelier-Stevens, Incorporated	152	* RCA Ltd Marsteller, Ltd.	14E,15E
* Advanced Micro Devices Keye Donna Pearlstein	17E	Exar Integrated Systems Regis McKenna Inc.	48	RCA Solid State Division Al Paul Lefton Company, Inc.	73,75,77
Advanced Micro Devices Keye/Donna/Pearlstein	10-11	Exact Electronics Hugh Dwight Advertising	17	RCL Electronics, Inc. Morvay Advertising Agency	14
Airfax Electronics American Marketing Management Inc.	20	Executone, Inc., Printact Relay Div. J.A. Richards	144	Rochester Gas & Electric Corp - Ad Group Hutchins/Darcy Inc.	142
Airfax Electronics Welch, Mirabile & Co., Inc.	124	* Fluke Marsteller	11E,12E,13E	* Rohde & Schwarz	1E
Allen Bradley Company Hoffman, York, Baker & Johnson Inc.	24	Fluke Manufacturing Co., John Bonfield Associates	9	Scanbe Manufacturing Corp. Warren C. Wilson & Associates	21
American Lava Corporation Sub. of Minnesota, Mining & Mfg. Co. Designers Inc.	132	General Magnetics McCarthy/Scelba/DeBiasi Adv. Agcy., Inc.	3rd Cov	Schauer Manufacturing Corp. Nolan, Keelor & Stites	136
American Power Systems Corp. Effenon/Nusbaum/Richard/Advertising	143	* General Radio Grad Associates	7E	* Schlumberger Scott MacTaggart Advertising	58-59
Amphenol Industrial Div., Bunker Ramo Corp. Marsteller, Inc.	22-23	Georgia Department of Community Development Gerald Ratshoon Advertising, Inc.	130	S. D. S. A. Public Service	138,154
Analog Devices Inc. Schneider Parker Guy., Inc.	80-41	Gould, Inc./Instrument Systems Div. Carr Liggett Adv., Inc.	155	Semtech Corporation Adgraphix Corporation	147
Ansley Electronics Corp. S. Michelson Advertising	123	GOVERNEMENT DU QUEBEC-MINISTRE DE L'INDUSTRIE ET DU COMMERCE J. Walter Thompson Company Limited	139	* Siemens Aktiengesellschaft Linder Presse Union GmbH	52
Anzac Electronics Ken Puleo Advertising	144,160	Hewlett Packard Richardson, Slegle, Rolfs & McCoy, Inc.	2	Signal Transformer Russell Technical Services, Inc.	138
APM-Hexseal The Sommer Agency Inc.	142	Hewlett Packard Dancer Fitzgerald Sample, Inc.	129	Siliconix Robertson West, Inc.	93
Associated Environmental Systems, Inc. A.D. Adams Advertising, Inc.	134	Hewlett Packard Richardson, Seigle, Rolfs & McCoy, Inc.	117	Sprague Electric Company Harry P. Bridge Company	8
Astro-Med Michael London Associates	78	Hewlett Packard Tallant/Yates Advertising, Inc.	1	Systron Donner Concord Instruments Fred Schott & Associates	51
Augat Creamer, Trowbridge, Case & Basford, Inc.	140	Hughes Aircraft Company Foote, Cone & Belding	155,57	* TEAC Corp. Dentsu Advertising Ltd.	15
Austin-Whyte Company Kalmar Advertising	135	Hutson Industries Greene, Webb Associates, Inc.	38	* Tekelec Airtronic S.P.F.D.	20E,9E
Beckman Instruments, Inc., Helipot Div. N.W. Ayer/Jorgensen/MacDonald, Inc.	58-59	‡ International Rectifier Corp., Semiconductor Division William E. Wilson Company	54	Tektronix Inc. McCann Erickson, Inc.	12-13
‡ Bourns, Inc. Marlborough Assoc., Inc.	52	Interstate Electronics Corp. Chris Art Studio Inc.	151	Teledyne Philbrick Ingalls Associates, Inc. Advertising	2nd Cov
* Canon Amsterdam N.V. Euro Advertising B.V.	4E	Invest Export Interwerbung	79	Teledyne Semiconductor Regis McKenna, Inc.	28
‡ Centralab Electronics Div., Globe-Union Inc. Action Communicators	60-61	Ithaco, Inc. Stahlka/Faller, Inc.	40	Texas Instruments Inc. Kenyon & Eckhardt Advertising, Inc.	18-19
Clairex Corporation Black-Russell-Morris	4th Cov.	Keithley Instruments, Inc. Chagrin Valley Marketing Associates	146	TRW, Electronic Components Division The Bowes Company	42-43
Communications Transistor Corp. Hall Butler Blatherwick, Inc.	127	Kepeco, Inc. Weiss Advertising	5	TRW, Electronics, Semiconductor Division The Bowes Company	7
Computer Devices Inc., Drumbeater	144,160,150	Kepco, Inc. Weiss Advertising	5	Unitrode Corporation Culver Advertising, Inc.	27
Concord Electronics Corp. Sound Advertising	143	Lambda Electronics Corp. Michel Cather, Inc.	46-47	Universal Instrument Corp. Conklin, Labs & Bebee, Inc.	112
Dahmen Burnett Electronics Weston Associates, Inc.	136	Litronix, Inc. Regis McKenna, Inc.	145	Wavetek Indiana Chapman Michetti Advertising	120
Data General Corporation Scali, McCabe, Sloves, Inc.	118-119	MFE Corporation Brightman Company, Inc.	160	Wima, Westermann	16
Data Test Corporation Hal Lawrence Inc.	148	Micro Power Systems Associated Ad Ventures, Inc.	76		
Datel Systems, Inc. John Dolan Advertising	66	Micro Systems Inc. McAward Associates	137		
Diacon Grant Rogondino Millard, Inc.	155	Microsystems International Limited Peter Barrett and Associates	33,35,37,39		
Digi-Data Corp. R & J Associates	152	‡ 3M Electro Products Division Batten, Barton, Durstine & Osborn, Inc.	131		
Digital Equipment Corp. Schneider Parker Guy, Inc.	62-63	Motorola/GED Botsford Ketchum Inc.	44-45		
‡ Eastman Kodak Company, Business Systems Markets Div. J. Walter Thompson Co.	15	Motorola Timepiece Electronics Unit Bozell & Jacobs, Inc.	142		
ELDEC Bonfield Associates	69	National Semiconductor Corp. Chiat/Day, Inc. Advertising	159		
Electronic Communications, Inc. W.M. Zemp & Associates, Inc.	128	* Philips N.V. Pit/T & M Division Broekies Communications Systems SA	54,2E-3E		
* Electro Scientific Industries Com/Mark Communications Group.	19E	Piezo Technology Inc. Shattuck/Roethner Advertising, Inc.	122		
		Piher International Scott Mac Taggart Advertising	65,64		
		Plastics Engineering Company Kuttner & Kuttner, Inc.	157		

Classified & Employment Advertising

F. J. Eberle, Manager 212-971-2557

EQUIPMENT (Used or Surplus New) For Sale	
American Used Computer Corp.....	156
Philip Fishman Co.....	156
Hamilton Standard.....	156
Jensen Tool & Alloys.....	156
Mountain West Alarm.....	156
Radio Research Instrument Co., Ltd.....	156

■ For more information on complete product line see advertisement in the latest Electronics Buyer's Guide
* Advertisers in Electronics International
‡ Advertisers in Electronics domestic edition

WITH TYPICAL MODESTY NATIONAL ANNOUNCES A NEW METHOD OF MEASURING TEMPERATURE THAT MAKES EVERY OTHER WAY LOOK SICK.

You're lookin' at it.

The world's first I.C. temperature transducer.

On a single monolithic integrated circuit chip, we've included a linear sensor to measure temperature, an amplifier for adjusting span and offsetting the output of the sensor, and a stable voltage reference so the transducer can be a temperature controller. It reads out in a real temperature scale (degrees Kelvin, not Ohms or microvolts). And comes calibrated to $\pm 4^{\circ}\text{C}$ over a -55°C to 125°C range.

Stack that up against the other ways to measure and control temperature:

Thermocouples that have the problem of low output, non-linearity, and require a cold junction reference.

Resistance sensors and Thermistors that need a stable excitation, and are non-linear.



And all three of those other ways need an electronic box to translate the sensor output into temperature, which increases the size and cost of the units.

Pretty sick.

For all you people dying to pick up the phone and place an order with your distributor, the numbers to order are LX5600AH/LX5600H (the 4-lead TO-5 package) and LX5700AH/LX5700H (4-lead TO-46 package).

Or for those not convinced yet, you can get details by calling out nearest branch listed below or write National Semiconductor Corporation, 2900 Semiconductor Drive, Santa Clara, California 95051.

With new, better products like this cranking off the production line all the time, it's sort of hard to remain humble.



NATIONAL

National Semiconductor Corp., 2900 Semiconductor Drive, Santa Clara, Calif. 95051; Scottsdale, Ariz. (602) 945-8473; Mountain View, Calif. (415) 961-4740; Sherman Oaks, Calif. (213) 783-8272; Tustin, Calif. (714) 832-8113; Miami, Fla. (305) 446-8309; Chicago, Ill. (312) 693-2660; Indianapolis, Ind. (317) 255-5822; Lenexa, Kan. (816) 358-8102; Glen Burnie, Md. (301) 760-5220; Burlington, Mass. (617) 273-1350; Farmington, Mich. (313) 477-0400; Minneapolis, Minn. (612) 888-4666; Englewood Cliffs, N.J. (201) 871-4410; Syracuse, N.Y. (315) 455-5858; Dayton, Ohio (513) 434-0097; Dallas, Tex. (214) 233-6801.

BUILD YOUR SALES WITH OUR PRINTER

provide your customers with the ease and speed of TAB card data handling!



Our DPC11EA accepts TTL/DTL BCD inputs. Model DPC11MA is the O.E.M. printing mechanism.

Print data with accurate registration on a pre-formatted three copy ticket.

Up to 11 columns and 20 consecutive lines can be indexed or printed.

Your instrument or computer can program floating decimal point, column suppression and 30 line/sec advance for positioning or ejecting the ticket.



MFE CORPORATION

Keewaydin Drive
Salem, New Hampshire 03079
Tel: 603-893-1921
TWX 710-366-1887
TELEX 94-7477

Advertising Sales Staff

Pierre J. Braudé [212] 997-3485
Advertising Sales Manager

Atlanta, Ga. 30309: Joseph Lane
100 Colony Square, 1175 Peachtree St., N.E.
[404] 892-2868

Boston, Mass. 02116: James R. Pierce
607 Boylston St. [617] 262-1160

Chicago, Ill. 60611:
645 North Michigan Avenue
Robert W. Bartlett (312) 751-3739
Paul L. Reiss (312) 751-3738

Cleveland, Ohio 44113: William J. Boyle
[716] 586-5040

Dallas, Texas 75201: Charles G. Hubbard
2001 Bryant Tower, Suite 1070
[214] 742-1747

Denver, Colo. 80202: Harry B. Doyle, Jr.
Tower Bldg., 1700 Broadway
[303] 266-3863

Detroit, Michigan 48202: Robert W. Bartlett
1400 Fisher Bldg.
[313] 873-7410

Houston, Texas 77002: Charles G. Hubbard
2270 Humble Bldg. [713] CA 4-8381

Los Angeles, Calif. 90010: Robert J. Rielly
Bradley K. Jones, 3200 Wilshire Blvd., South Tower
[213] 487-1160

New York, N.Y. 10020
1221 Avenue of the Americas
Warren H. Gardner [212] 997-3617
Michael J. Stoller [212] 997-3616

Philadelphia, Pa. 19102: Warren H. Gardner
Three Parkway,
[212] 997-3617

Pittsburgh, Pa. 15222: Warren H. Gardner
4 Gateway Center, [212] 997-3617

Rochester, N.Y. 14534: William J. Boyle
9 Greylock Ridge, Pittsford, N.Y.
[716] 586-5040

San Francisco, Calif. 94111: Don Farris
Robert J. Rielly, 425 Battery Street,
[415] 362-4600

Paris: Alain Offergeld
17 Rue-Georges Bizet, 75 Paris 16, France
Tel: 720-73-01

Geneva: Alain Offergeld
1 rue du Temple, Geneva, Switzerland
Tel: 32-35-63

United Kingdom & Scandinavia: Keith Mantle
Tel: 01-493-1451, 34 Dover Street, London W1

Milan: Robert Saidel
1 via Baracchini, Italy Phone 87-90-656

Brussels: Alain Offergeld
23 Chaussee de Wavre
Brussels 1040, Belgium
Tel: 13-73-95

Frankfurt/Main: Fritz Krusebecker
Liebigstrasse 27c, Germany
Phone 72 01 81

Tokyo: Tatsumi Katagiri, McGraw-Hill
Publications Overseas Corporation,
Kasumigaseki Building 2-5, 3-chome,
Kasumigaseki, Chiyoda-Ku, Tokyo, Japan
[581] 9811

Osaka: Ryji Kobayashi, McGraw-Hill
Publications Overseas Corporation, Kondo
Bldg., 163, Umegae-cho Kita-ku, Japan [362] 8771

Australasia: Warren E. Ball, ITO Box 5106,
Tokyo, Japan

Business Department

Stephen R. Weiss, Manager
[212] 997-2044

Thomas M. Egan,
Production Manager [212] 997-3140

Carol Gallagher
Assistant Production Manager [212] 997-2045

Dorothy Carter, Contracts and Billings
[212] 997-2908

Frances Vallone, Reader Service Manager
[212] 997-6057

Electronics Buyers' Guide

George F. Werner, Associate Publisher
[212] 997-3139

Regina Hera, Directory Manager
[212] 997-2544

30-CPS



only 22 lbs.

IBM 2741* portable?

Yes. And now.
From CDI.



**COMPUTER
DEVICES INC.**

9 Ray Avenue
Burlington, Mass. 01803
Tel. (617) 273-1550

a **TECHVEN** Corporate Partner *Compatible

Circle 178 on reader service card

BROADBAND 50-75 ohms

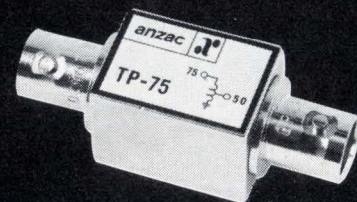

TRANSFORMER

MODEL TP-75

- 2-200 MHz Frequency Range
- 0.25dB Insertion Loss
- 1.1:1 VSWR
- \$55/Stock Availability

anzac
ELECTRONICS



39 Green Street, Waltham, Mass.
(617) 899-1900 • TWX 710-324-6484