

5 1/4" MICRO FLOPPYDISK DRIVE

MP-F17W

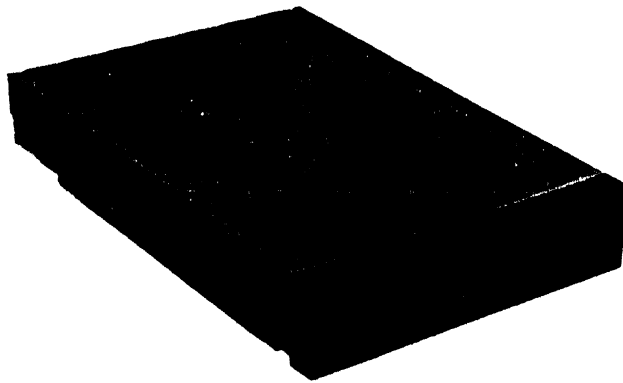

Rev. A

70112

SONY[®]
SERVICE MANUAL

TABLE OF CONTENTS

	<u>Description</u>	<u>Page</u>
SECTION 1	INTRODUCTION	1
SECTION 2	TOOLS AND MEASURING INSTRUMENTS	2
2-1	GENERAL AND SPECIAL TOOL LIST	2
2-2	SPECIAL TOOLS	3
2-3	SYSTEM CONFIGURATIONS	15
SECTION 3	TROUBLESHOOTING	18
3-1	BEFORE TROUBLESHOOTING	18
3-2	TYPES OF ERROR ON A SYSTEM LEVEL	18
3-3	FAULT DIAGNOSIS BY MFD FUNCTION CHECKER II	18
3-4	FINAL CHECK	26
3-4-1	Final Check for 1MByte Mode	26
3-4-2	Final Check for 2MByte Mode	30
3-4-3	Error Message	34
SECTION 4	PART REPLACEMENT	35
4-1	COVER ASS'Y REPLACEMENT	35
4-2	FRONT PANEL ASS'Y AND EJECT BUTTON REPLACEMENT	35
4-3	LG-2 MOUNTED BOARD REPLACEMENT	35
4-4	MT-2 MOUNTED BOARD REPLACEMENT	36
4-5	HALL IC ASS'Y REPLACEMENT	36
4-6	CASSETTE HOLDER ASS'Y REPLACEMENT	37
4-7	SLIDE PLATE ASS'Y REPLACEMENT	37
4-8	00 SENSOR REPLACEMENT	38
4-9	HEAD CARRIAGE ASS'Y REPLACEMENT	38
4-10	STEPPING MOTOR ASS'Y (ROTOR ASS'Y AND STATOR ASS'Y) REPLACEMENT	39
4-11	OIL DAMPER REPLACEMENT	39
4-12	COMBINATION OF HEAD CARRIAGE ASS'Y AND LG-2 MOUNTED BOARD	40
SECTION 5	CHECK AND ADJUSTMENT	41
5-1	RADIAL ALIGNMENT AND TRK00 SENSOR	41
5-2	HEAD COMPLIANCE	46
5-3	INDEX PHASE	46
5-4	HEAD CLEANING	47
SECTION 6	PARTS LOCATION AND LIST (For MP-F17W-50L)	49
6-1	PARTS ASS'Y LOCATION	49
6-2	MECHANICAL PARTS LIST	51
6-3	OVER ALL DIAGRAM	52
6-4	CIRCUIT DIAGRAM	53
6-5	PARTS LAYOUT	56
6-6	ELECTRIC PARTS	58
SECTION 7	PARTS LOCATION AND LIST (For MP-F17W-50D)	62
7-1	PARTS ASS'Y LOCATION	62
7-2	MECHANICAL PARTS LIST	64

TABLE OF CONTENTS

<u>Description</u>	<u>Page</u>
7-3 OVER ALL DIAGRAM	65
7-4 CIRCUIT DIAGRAM	66
7-5 PARTS LAYOUT	69
7-6 ELECTRIC PARTS	71
SECTION 8 TRANSISTORS / DIODES / ICS PIN ARRANGEMENT	75

WARNING

It may be possible that the Head Gearing Arm is the unit is damaged, if the unit head turn upside down without the Cover Arm installed. In order to avoid such trouble, make sure that the drive is loaded to disk in mode the head turned upside down as shown in the drawing.

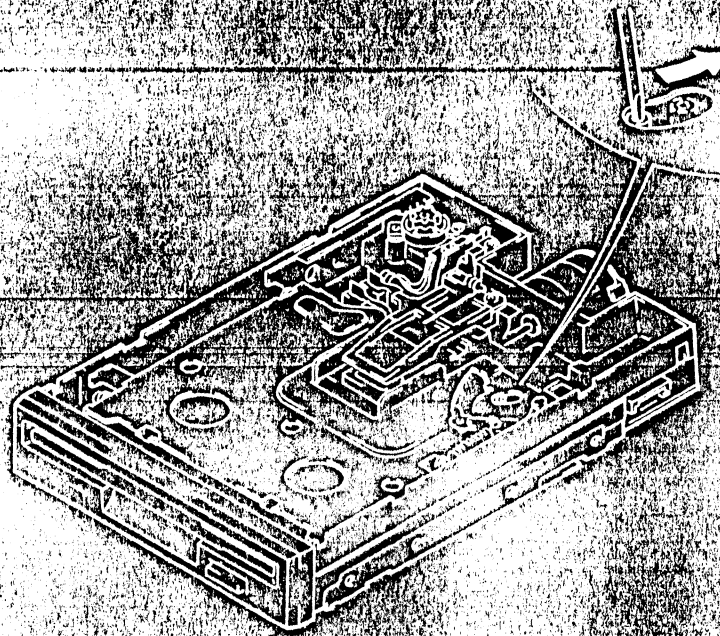

Setting of Disk In mode

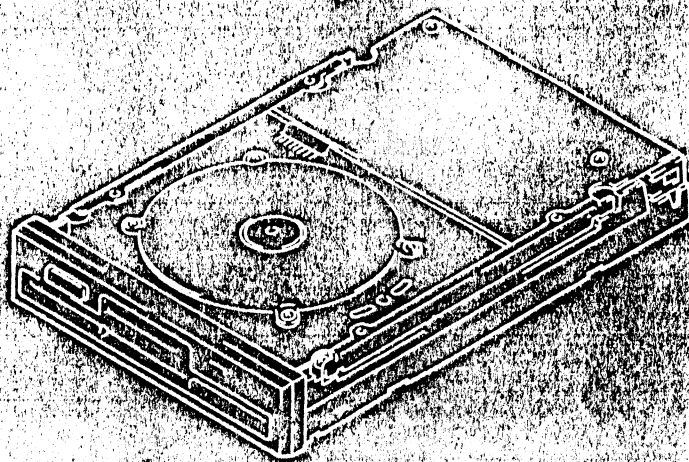

SECTION 1

INTRODUCTION

This manual is a maintenance guide for models MP-F17W-50D and MP-F17W-50L.

SECTION 2 describes disks and tools necessary for maintenance.

SECTION 3 provides fault diagnostic procedures that may require spare parts or some adjustments.

The overall check after removals and adjustments will be included in this section.

SECTION 4 and 5 cover parts replacements and adjustments, respectively.

SECTION 6 and 7 consist of circuit diagrams, ass'y drawings, and parts lists.

SECTION 2

TOOLS AND MEASURING INSTRUMENTS

2-1 GENERAL AND SPECIAL TOOL LIST

The tools and measuring instruments for performing maintenance on the MP-F17W series are listed below.

a. General Tools

	SONY parts No.
+ driver 2mm	(7-700-749-01)
+ driver 2.6mm	(7-700-749-03)
Tweezers	(7-700-753-02)
Round nose plier	(7-700-757-01)
Cutter	(7-700-758-02)
LR Driver	(3-985-911-11)
CP/M (SMW-7002)	
Soldering iron (20W)	
Desoldering metal braid	
DC power supplier	
+5VDC±5%, 1.5A min., +12VDC±5%, 1.5A min.	
Tester	

b. Special Tools

MFD Function Checker II	(J-623-916-0A)
IF Board 52/53	(J-623-904-0A)
Fixture-10	(J-623-909-0A)
SMC System	

For AC 120V	For AC 220V
SMI-7011/SMI-7011A/ SMI-7012/SMI-7012A	SMC-70GP
SMC-70	
KX-13HG1	PVM-1371QM
SMK-0001	SMK-0002
SMI-7016	SMI-7016

Digitizer	(J-623-022-0A)
Conversion Cable II	(J-623-021-0A)
Radial Alignment Adj. Driver	(J-623-810-0A)
TRK00 Adj. Lever	(J-623-910-0A)
Index Adj. Lever	(J-623-911-0A)
Pad Weight	(J-609-158-0A)
Conversion Cable (01) only for MP-F17W-50D	(J-623-907-0A)
Torque Driver with two bits	(J-623-807-0A)
Power Cable	(J-609-130-0A)
Interface Cable	(J-609-201-0A)

c. Measuring Equipment

Oscilloscope Dual Trace 20MHz
 Universal Counter Resolution 0.1msec.

d. Disks

MFD System Disk (OR-D176VA)	(8-969-920-54)
Cleaning Disk (OR-D29WA)	(8-960-009-39)

This disk can be used for head clean.

HD Level disk (OR-D206WA)	(8-969-920-11)
Level Disk (OR-D46WA)	(8-960-009-40)

These disks are used to check the read amplifier gain. The self-read/write operation can be checked with these disks and the SMC System.

2M Dynamic Inspection Disk +30 (OR-D222WA)	(8-969-920-62)
--	----------------

Dynamic Inspection Disk +30 (OR-D51WA)	(8-960-009-44)
--	----------------

2M Dynamic Inspection Disk -30 (OR-D223WA)	(8-969-920-63)
--	----------------

Dynamic Inspection Disk -30 (OR-D52WA)	(8-960-009-45)
--	----------------

These disks can be used in the final check for a drive with the SMC System.

Note: (+) indicates that data has been recorded in the inner side of tracks.

(-) indicates that data has been recorded in the outer side of tracks.

	OR-D51WA/OR-D222WA	OR-D52WA/OR-D223WA
Side 0/1	Offset of +30µm for all formatted tracks	Offset of -30µm for all formatted tracks

Content of Dynamic Inspection Disk

50 Auto Disk (OR-D157WA)	(8-960-010-60)
--------------------------	----------------

This disk has prerecorded data such as Cat's eye pattern and Index signal to check and adjust the off-tracking and index position.

	Signal	Tracks
Side 0/1	Index Burst Cat's Eye Pattern	40
Side 0	Cat's Eye Pattern	00, 22, 27 31, 36, 45 49, 54, 58 63, 79
	2F	04
Side 1	2F(+30µm off track)	76

Content of 50 Auto Disk

e. Expendable and Chemical Supplies

Sony Oil (7-661-018-01)
 Molykote Grease (7-662-001-81)
 Bamboo Stick

2-2 SPECIAL TOOLS

2-2-1 MFD Function Checker II

(1) MFD Function Checker II configuration (Refer to Fig. 2-1)

Main Checker Board
 34P Flat Cable
 Power Cable (2 pieces)

(2) MFD Function Checker II function

(2)-1 Switches

- ① SW16... Set this switch to the "250Kbps" side for 1MByte mode. ("500Kbps" side for 2MByte mode.)
- ② STEP OUT (IN)... Steps the head outwards (inwards).
 The head continuously moves if STEP IN or OUT switch is kept pressed.
- ③ WDSSEL... Selects such write data as "2F", "1F", "M", "W" or "DC".

- ④ WRITE... Records data specified by the WDSSEL switch, onto one track.
- ⑤ CHGRST... Resets the DSKCHG signal. (for eject motor installed version, eject the disk)
- ⑥ INUSE... This switch is used to light the INUSE lamp.
- ⑦ HDSL... Selects one of two heads (side 0 or side 1) for a double sided. (This switch is invalid for single sided version.)
- ⑧ MON... This is used to operate the Disk Motor.
- ⑨ DRIVE SELECT... Selects the disk drive. The number of this DRIVE SELECT must agree with the DRIVE SELECT number of the drive under test. The number embossed on the component itself (1,2,3,4) is not that assigned for the drive select.
- ⑩ RESET... Resets the CPU.
- ⑪ STEP RATE... Set this switch to "3ms" for the MP-F17W series.
- ⑫ TRACK 00 ADJUST... This starts the measurement of the TRK 00 sensor level.

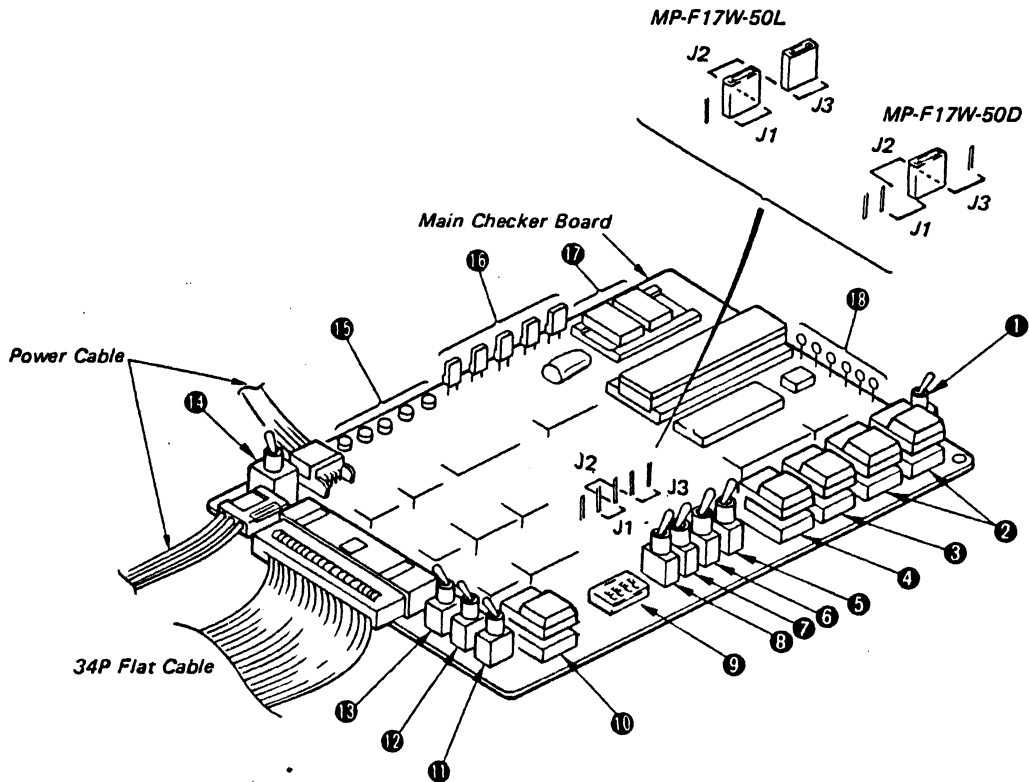

Fig. 2-1 MFD Function Checker II Configuration

- 13 SW4... Set this switch to "A" for MP-F17W series.
- 14 SW1... Feeds power supply voltage of +5V and +12V to CN3 (34pin connector).
Set this switch to "34+4" side for the MP-F17W series.

(2)-2 Indicators

- 15 WDSSEL... They indicate the selected position on the WDSSEL switch.
- 16 I/F signals... They indicate the states of TRK 00, RDY/HDSN, DSKCHG, WRTPRT, and INDEX, respectively.

The TRK 00, WRTPRT, RDY/HDSN, and DSKCHG indicators are lit when the respective I/F signals are low (true). The INDEX indicator blinks when the INDEX signal is applied to the board.

- 17 Track Position... Indicates the current track position.

(2)-3 Test Points

- TP-1, TP-8, TP-9; GND
- TP-2; MON
- TP-3; INDEX
- TP-4; RDDATA
- 18 TP-5; WRTGT
- TP-6; WRTDT
- TP-7; STEP
- TP-10; EXT
- TP-11; TRG

- (3) Part Layout and Circuit Diagram on MFD Function Checker II. (Refer to Fig. 2-2, 2-3)

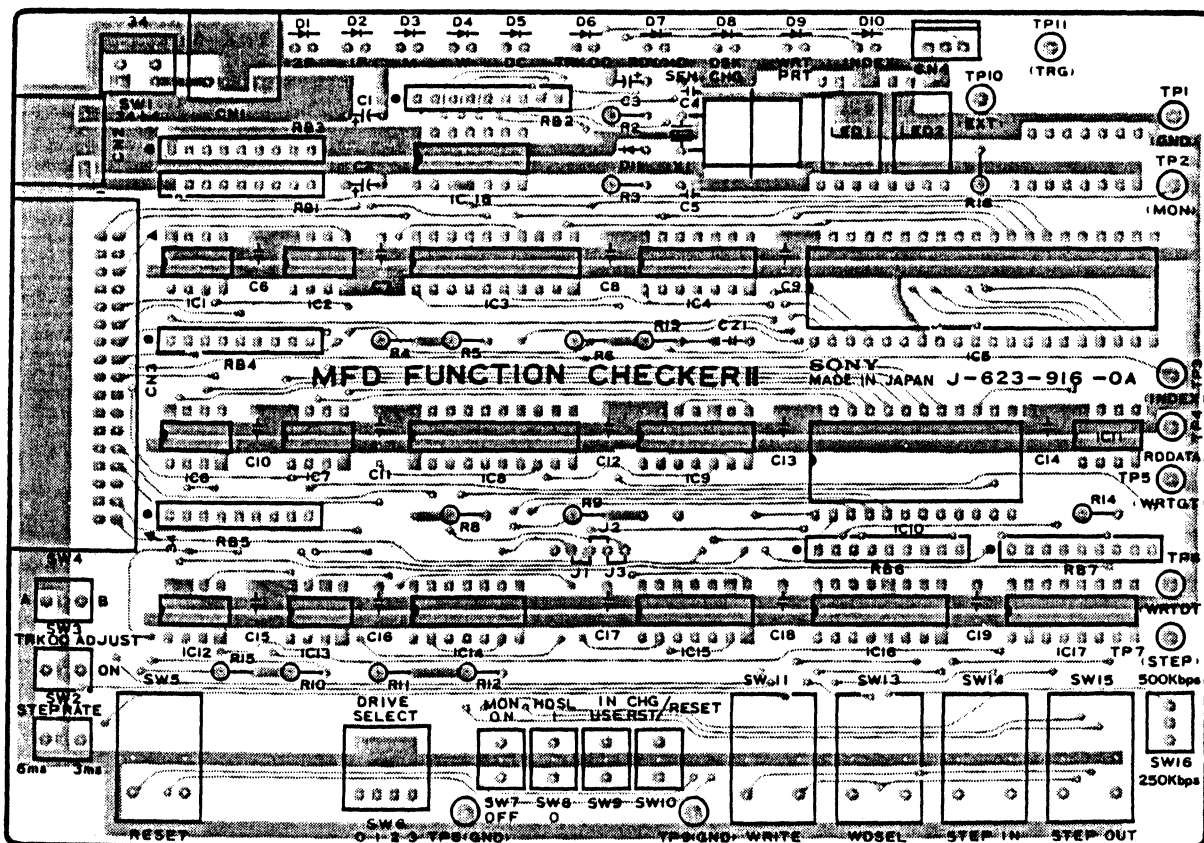

Fig. 2-2 Part Layout on MFD Function Checker II

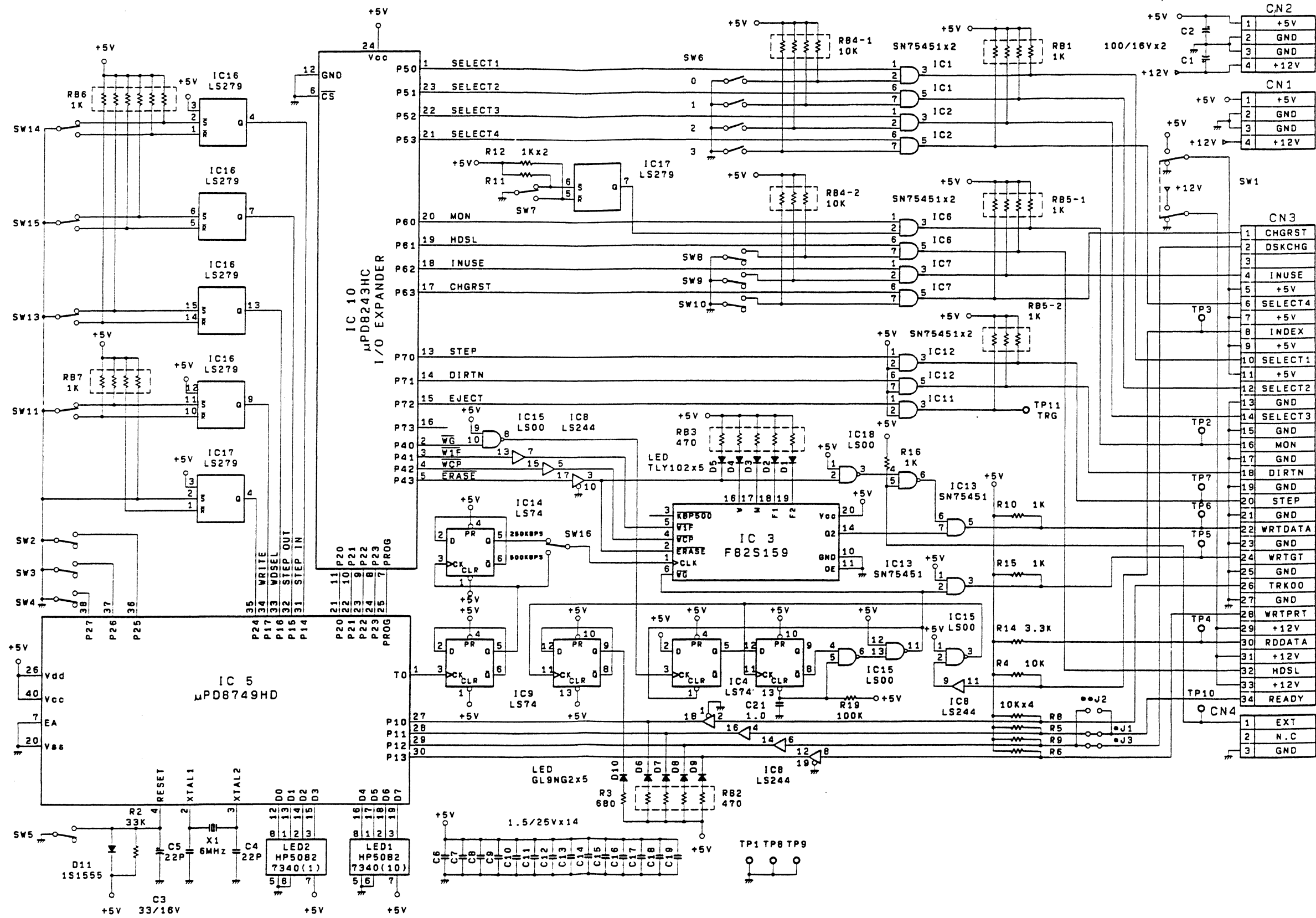

Fig. 2-3 MFD Function Checker II Circuit Diagram

2-2-2 IF Board 52/53

(1) IF Board 52/53 configuration (Refer to Fig. 2-4)

Main IF Board

RF Cable

IF Cable (34pin)

(2) IF Board 52/53 function

(2)-1 Switches

① MOTOR ON..... Sets the motor of the unit to rotate.

② POWER SEL (CN1)..... Feeds power supply voltage of +5V and +12V to CN1 (34pin connector).

Set the this switch to "off" for MP-F17W series.

(2)-2 Indicators

③ D1/D2..... These indicators are lit, during the actual power supply of +5V and +12V to 34pin connector. No indication for MP-F17W series.

④ D3/D4..... These indicators are lit, during actual power supply of +5V and +12V to IF board 52/53.

(2)-3 Test Points

⑤ RF out/TRK00/GND..... These test terminals are used for radial alignment adjustment. (Refer to 5-1)

(3) Part Layout and Circuit Diagram on IF Board 52/53. (Refer to Fig. 2-5, 2-6)

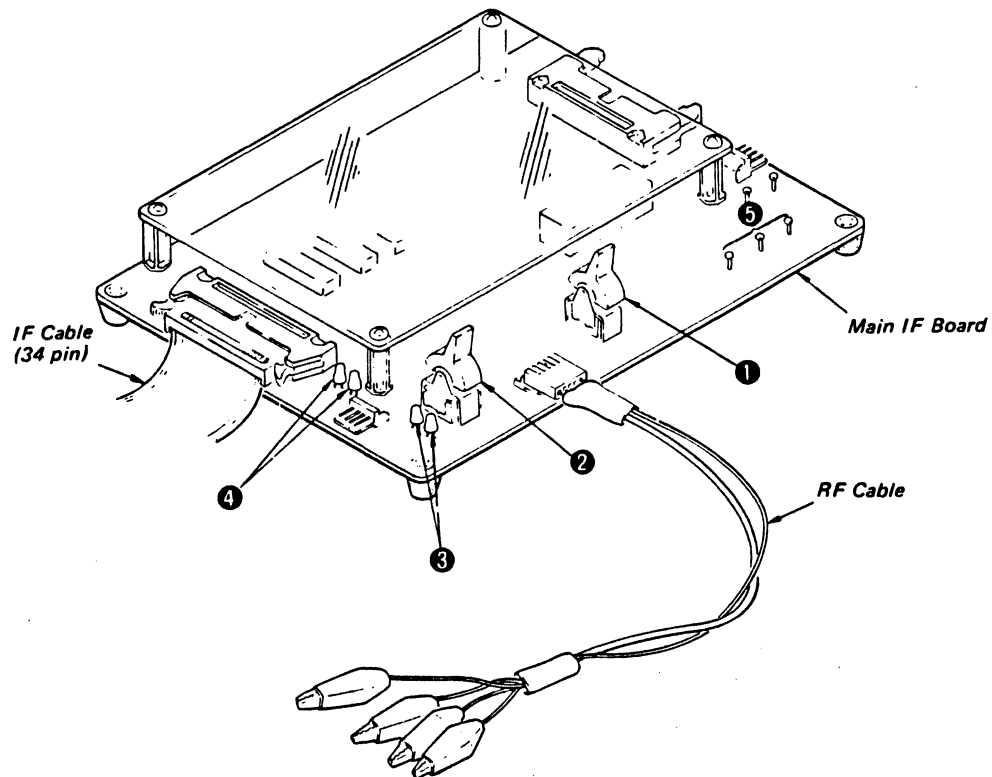

Fig. 2-4 IF Board 52/53 Configuration

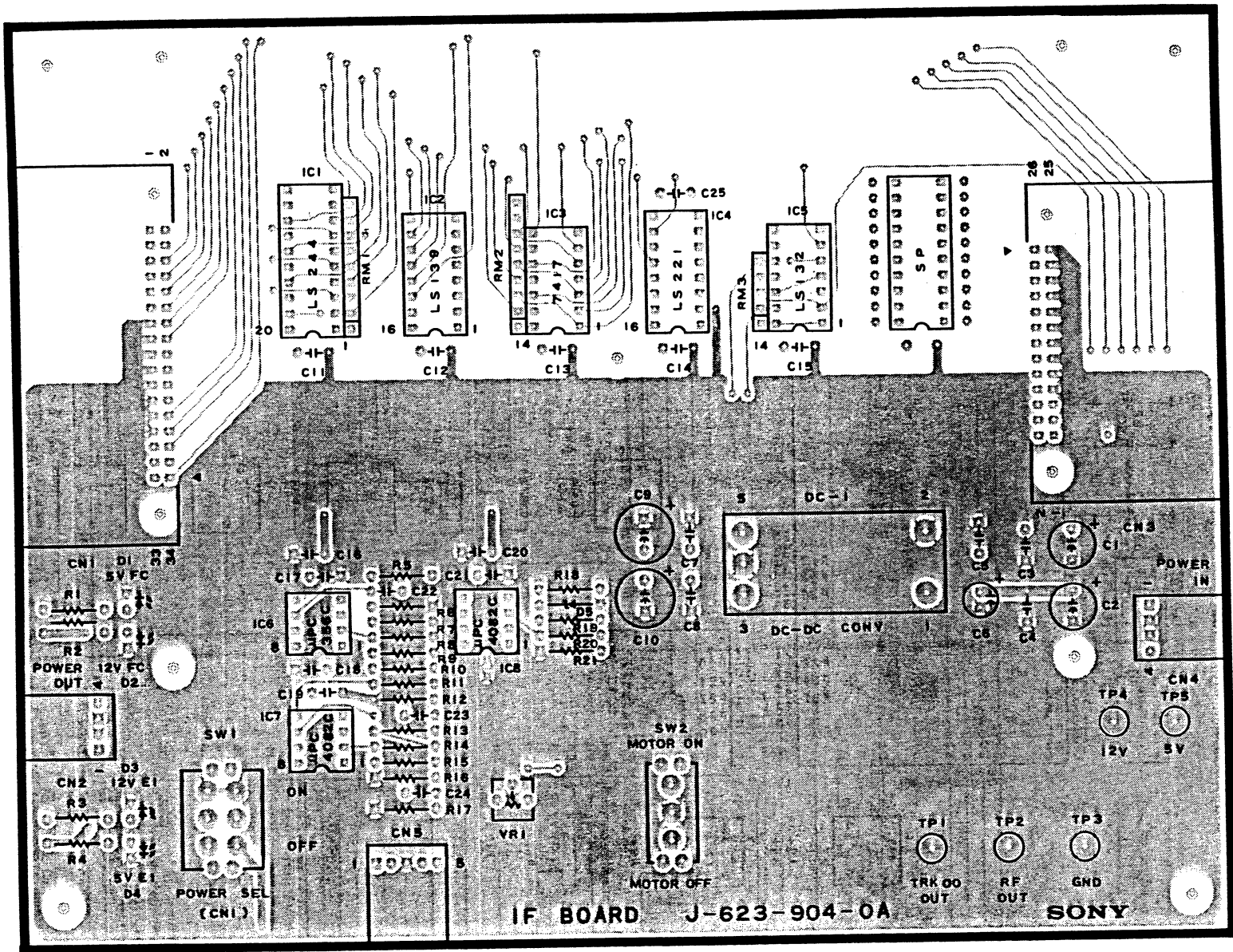

Fig. 2-5 Part Layout on IF Board 52/53

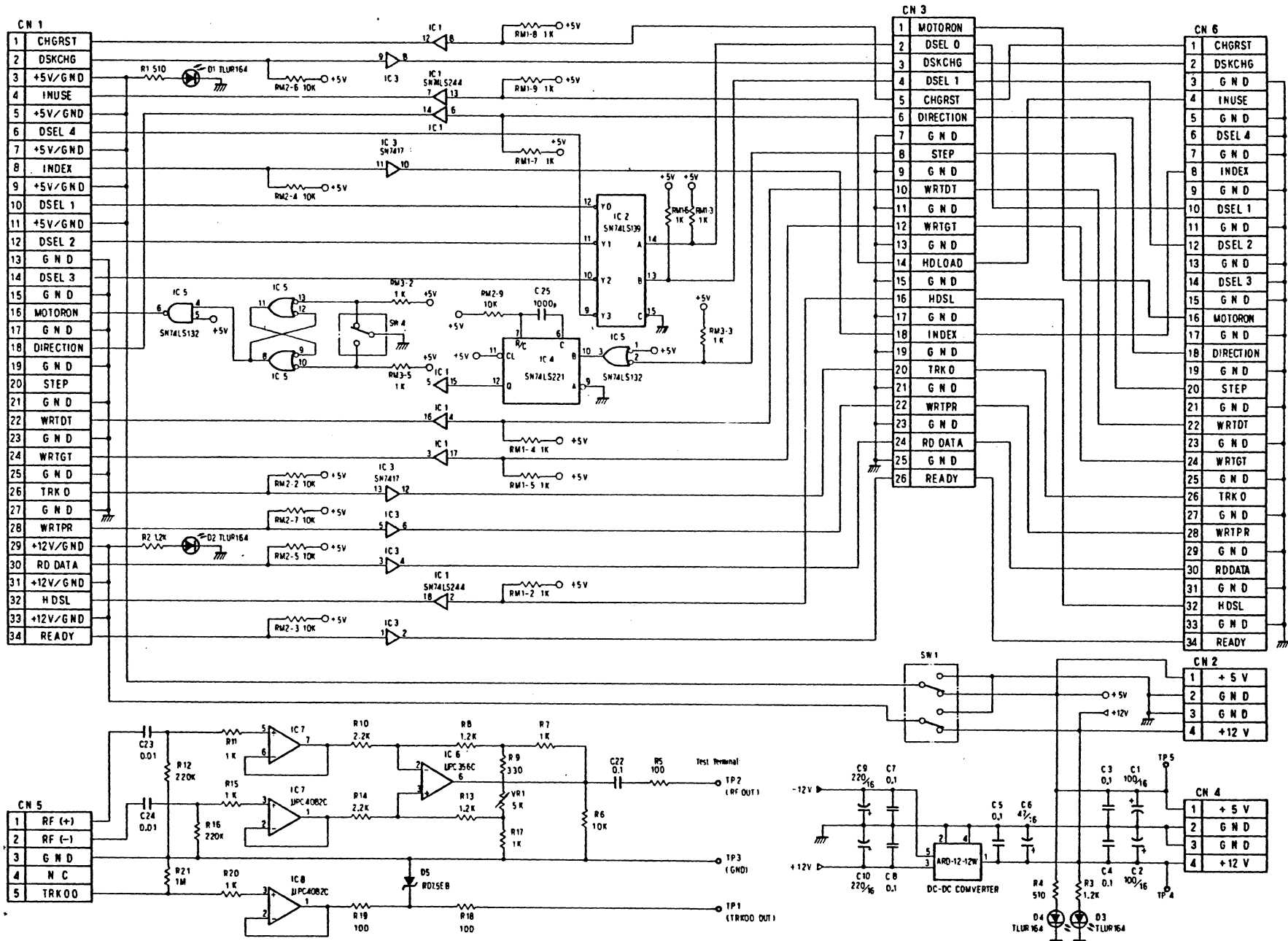

Fig. 2-6 IF Board Circuit Diagram

2-2-3 Digitizer

Digitizer is used for Radial Alignment and TRK 00 Sensor adjustment.

- (1) Digitizer configuration (Refer to Fig. 2-7)

Digitizer Board

IF Cable

A/D Harness

- (2) Part Layout and Circuit Diagram on Digitizer. (Refer to Fig. 2-8, 2-9)

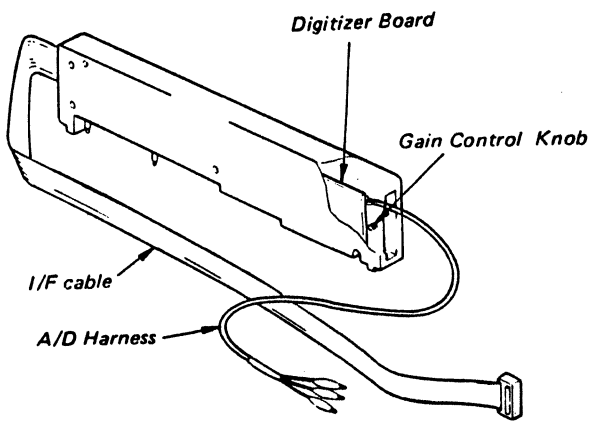

Fig. 2-7 Digitizer Configuration

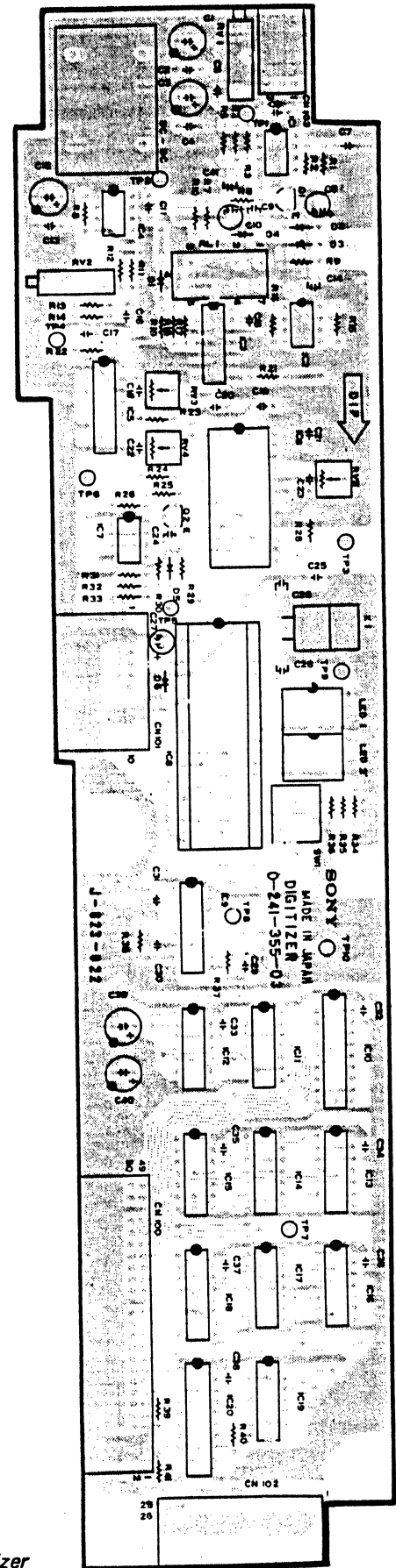

Fig. 2-8 Part Layout on Digitizer

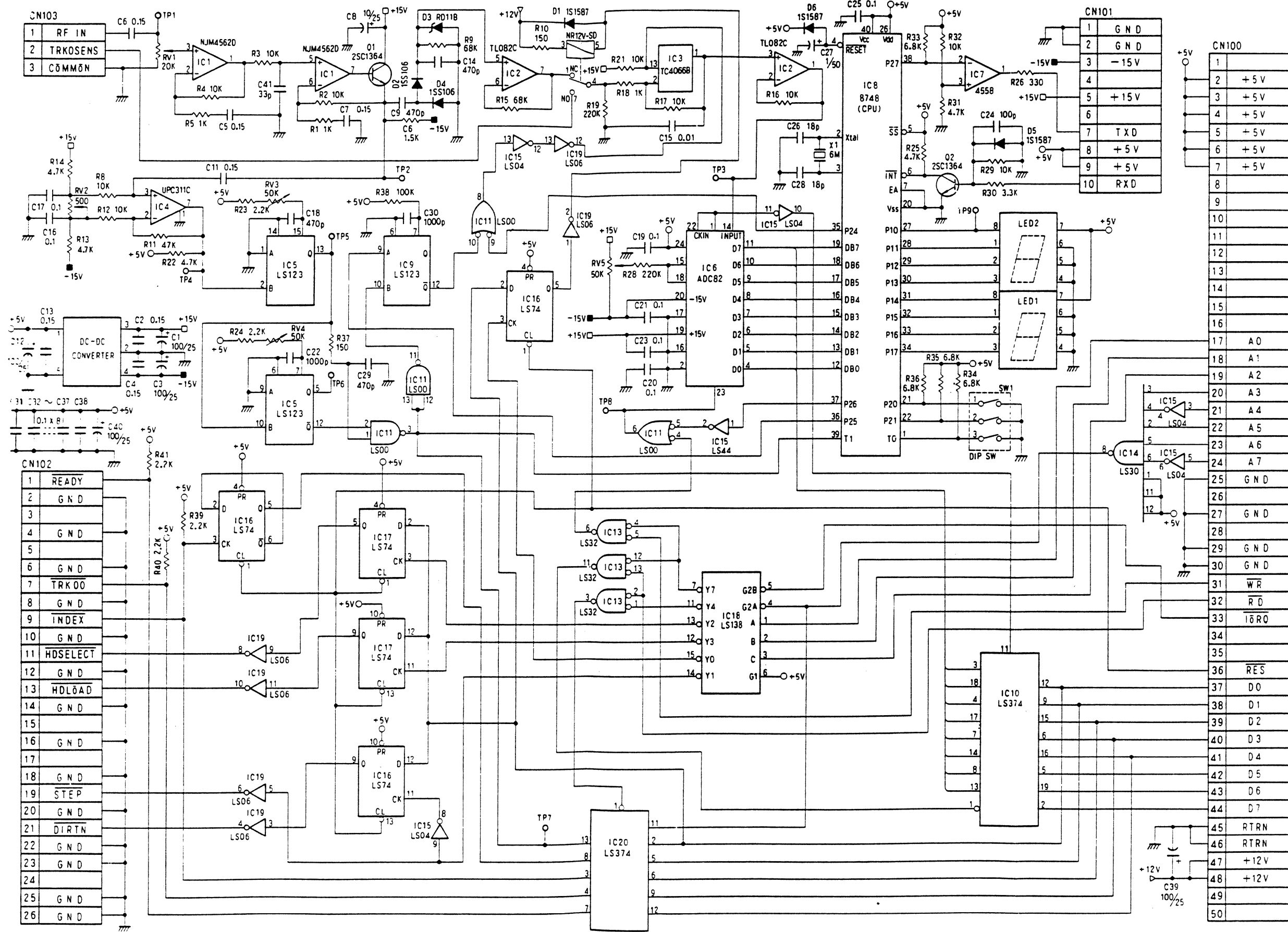

Fig. 2-9 Digitizer Circuit Diagram

2-2-4 Fixture-10

(1) Fixture-10 configuration (Refer to Fig. 2-10)

Fixture-10

FG PCB

(2) Fixture-10 function

Switch

① XADJ... This switch is used for Radial Alignment Adjustment. (Refer to 5-1)

(3) Part Layout and Circuit Diagram on FG PCB. (Refer to Fig. 2-11, 2-12)

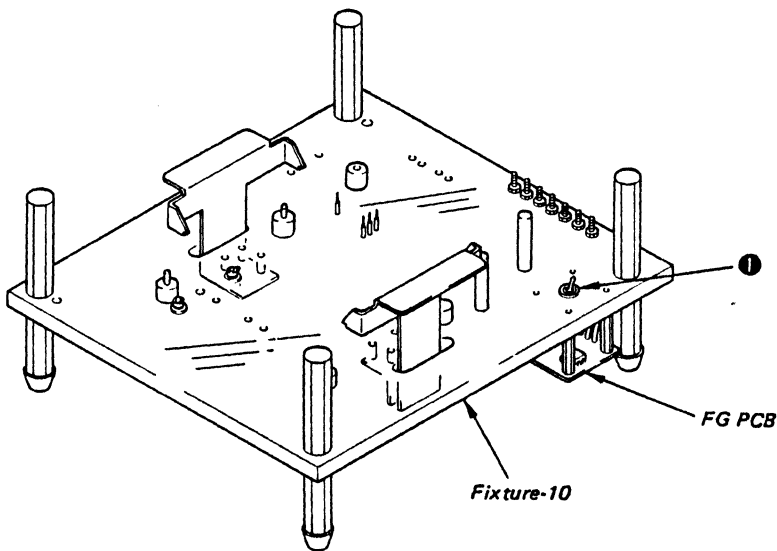

Fig. 2-10 Fixture-10 Configuration

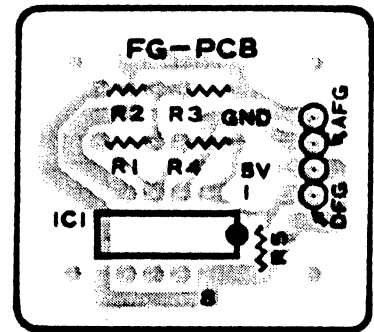

Fig. 2-11 Part Layout on FG PCB

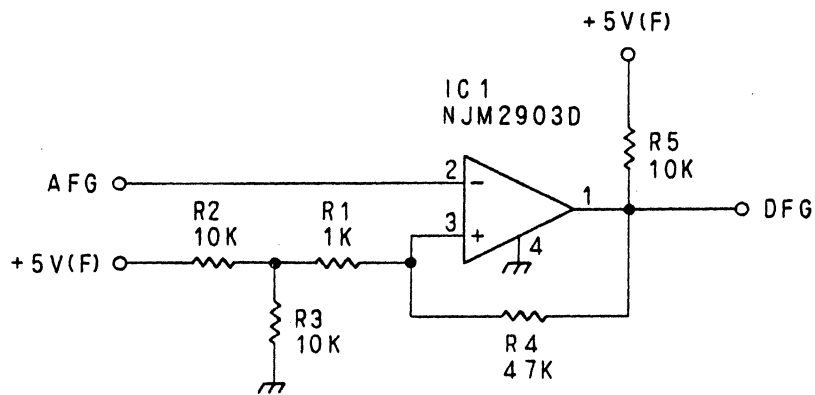

Fig. 2-12 FG PCB Circuit Diagram

(4) Installation procedure of Index Adj. and TRK00 Adj. levers into Fixture-10. (Refer to Fig. 2-13)

- a. Remove two screws (PSW4x14) from TRK00 Adj lever, install the lever on the acryl plate of Fixture-10 and secure it with two screws, as shown.
- b. Separate screw (K2.6x10), washers and knob from Index Adj lever. Install the lever itself on the acryl plate of Fixture-10 and secure it with the screw, washers and the knob, as shown.

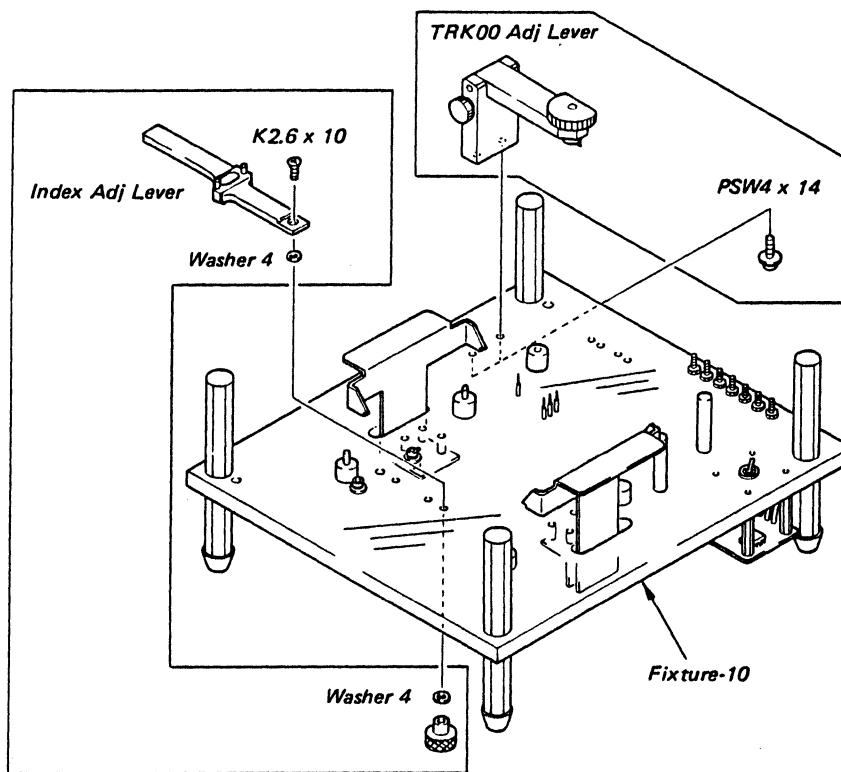

Fig. 2-13 Index Adj. and TRK00 Adj. Levers Installation

2-3 SYSTEM CONFIGURATIONS

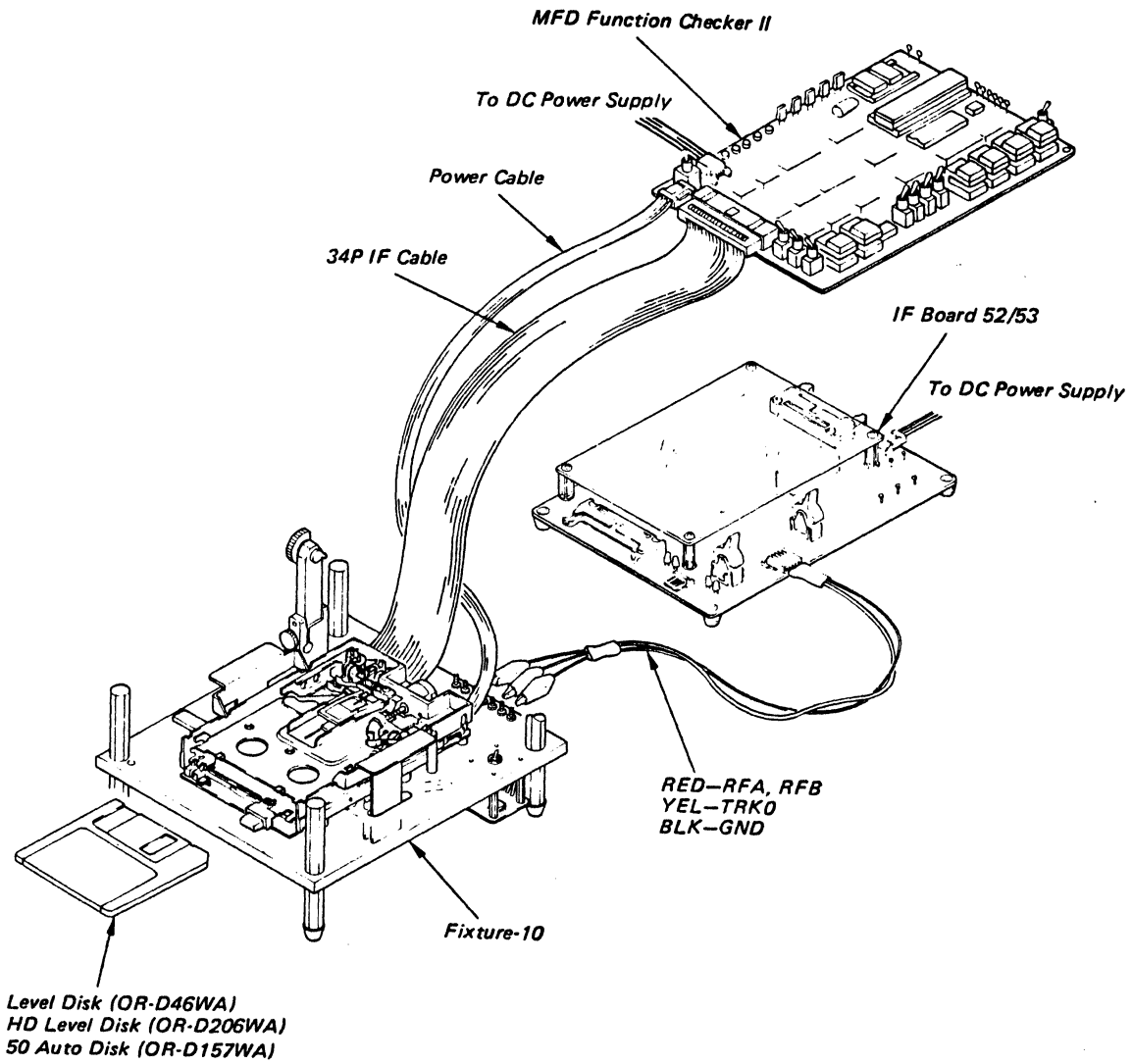

Fig. 2-14 Configuration for Function Check

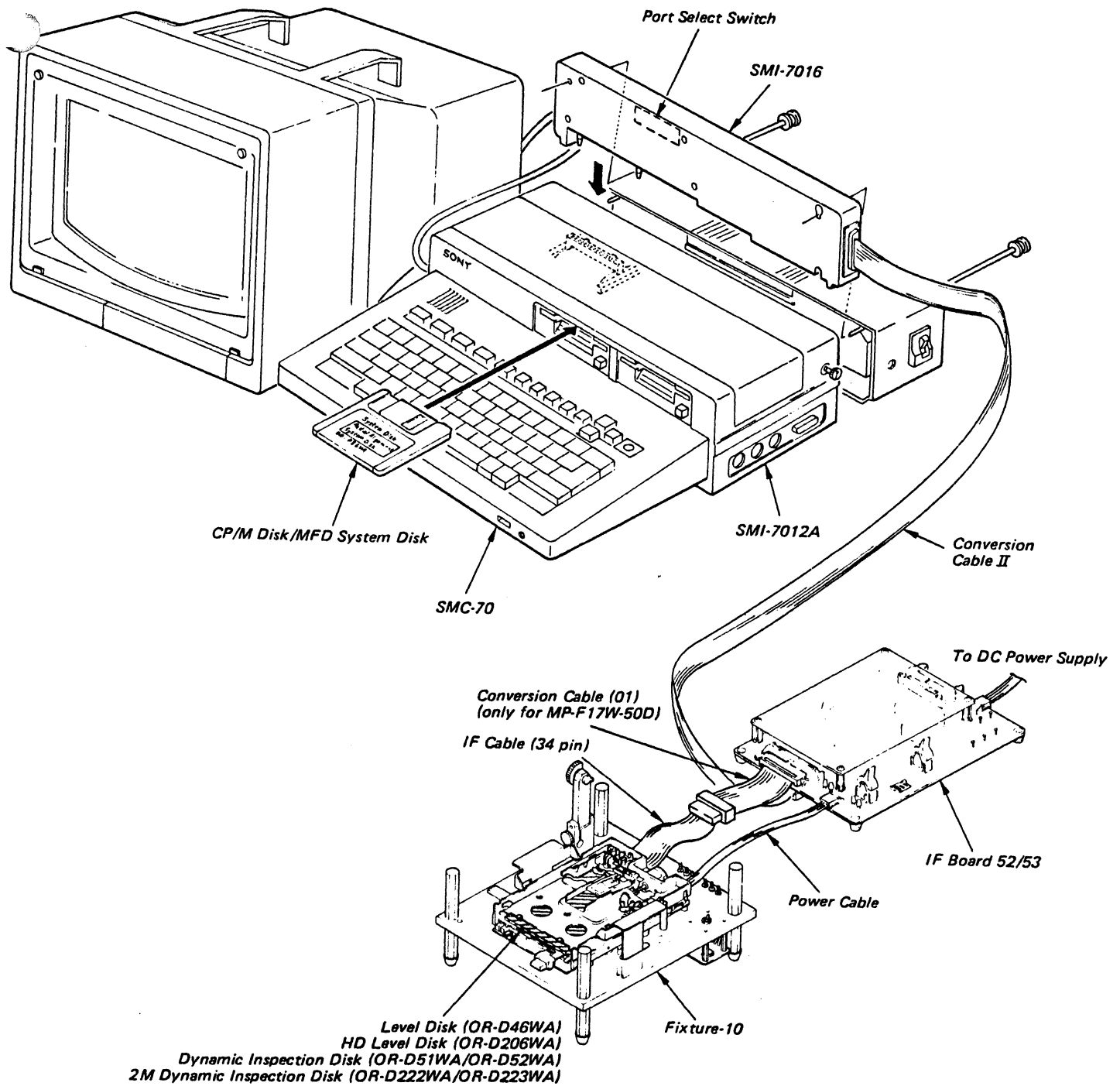

Fig. 2-15 System Configuration for Drive Test

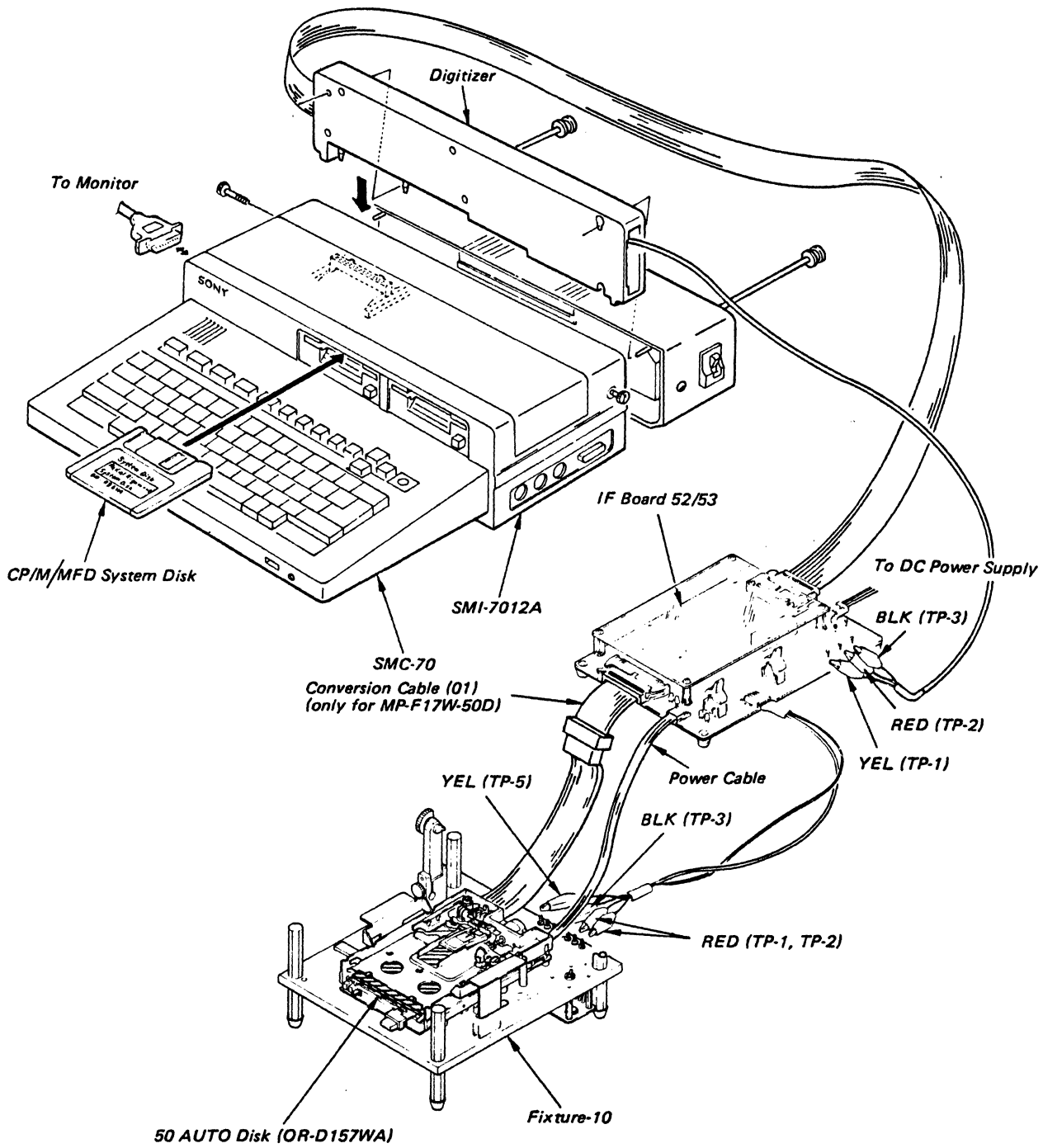

Fig. 2-16 System Configuration for Radial Alignment

SECTION 3

TROUBLESHOOTING

SECTION 3 describes the methods of troubleshooting. 3-2 refers to several errors specified in a system level. 3-3 describes normal operations and the check points for abnormal operations. These descriptions define the Error Spot under operating conditions.

3-1 BEFORE TROUBLESHOOTING

The following procedures are recommended to see if the drive is really faulty or not:

- a. Incorrect operational procedure
- b. program error of host system
- c. Poor connection with host system
(esp. GND-related connection, frame GND, etc.)
- d. Defective disk. Check that same trouble occurs with other disks.
- e. Environmental conditions (where electrical noise easily jumps into signal)
- f. Influence of strong magnetic field
- g. Wrong supply voltage
- h. Wrong drive selection

3-2 TYPES OF ERROR ON A SYSTEM LEVEL

3-2-1 Soft Error

Soft error are caused by:

- a. Dirty head
- b. Electrical noise
- c. Tracking error
- d. Poor connection with system
(GND-related connection)
- e. Incorrect motor speed
- f. Incorrect head compliance

Clean the head first by cleaning disk. Check for index pulse interval and head compliance and then read error spot more than several times. If not readable, move the head to the adjacent track in the same direction as before, then return to the desired track, and read. If readable this time, check radial alignment. (Refer to 5-1) If not readable yet, the error is not recoverable.

3-2-2 Write Error

To determine which of the disk or the drive fails the disk should be replaced by other disks and check that there still exists write error.

If write error does not exist any more, remove the old one. If write error exists with use of any disk, drive might cause write error.

3-2-3 Seek Error

Seek error comes from:

- a. Head movement is incorrect because electrical noise jumps into signal.
- b. Head driving system might be at fault. If it is not readable after re-calibration, drive might be at fault.

3-2-4 Interchange Error

If data written on one drive is readable correctly on another drive, but not by other drives, interchange error exists.

Interchange errors are caused by:

- a. Head is not properly positioned.
- b. Motor speed is not correct.
- c. Optimum head output level, offset and head compliance are not obtained.
- d. Chucking mechanism does not work.

3-3 FAULT DIAGNOSIS BY MFD FUNCTION CHECKER II

3-3-1 describes check method for normal operations in accordance with the predetermined procedures.

3-3-2 describes check points for abnormal operations which come out in accordance with the above procedures.

3-3-1 Normal Operation

Pre-setting:

- a. Connect the drive to MFD Function Checker II. (Refer to Fig. 2-14)
- b. Set the DRIVE SELECT switch (S101) on the disk drive to "0" (most right side).
- c. Set the XADJ switch on the Fixture-10 to "OFF".
- d. Set SW1 switch on the MFD Function Checker II to "34+4".
- e. Set the STEP RATE, TRK 00 ADJUST and SW4 switches to "3ms", "off" and "A" side respectively.
- f. Set the MON, HDSL and INUSE switches to "off", "0" and "upper" sides respectively.
- g. Slide all digit switch (0,1,2,3) of the DRIVE SELECT to the "lower" side.
- h. Set the SW16 switch to "500Kbps" side for 2MByte mode. ("250Kbps" side for 1MByte mode.)

Procedure	Step	Operation										
1	Power On	1. The disk motor remains stopped.										
2	Drive Select	<p>1. The W RTPRT indicator and In Use lamp light only when the DRIVE SELECT switch on the MFD Function Checker II and the DRIVE SELECT switch (S101) on the disk drive are set as follows:</p> <table border="1" style="margin-left: auto; margin-right: auto;"> <thead> <tr> <th>Function Checker II</th> <th>Disk drive (S101)</th> </tr> </thead> <tbody> <tr> <td>3</td> <td>3</td> </tr> <tr> <td>2</td> <td>2</td> </tr> <tr> <td>1</td> <td>1</td> </tr> <tr> <td>0</td> <td>0</td> </tr> </tbody> </table> <p>Otherwise, these indicators go out.</p>	Function Checker II	Disk drive (S101)	3	3	2	2	1	1	0	0
Function Checker II	Disk drive (S101)											
3	3											
2	2											
1	1											
0	0											
3	Stepping	<p>1. When the STEP OUT switch is pressed, the head is continuously stepped out until it arrives at TRK00. (When the head is located on TRK00, the TRK00 indicator lights.)</p> <p>2. When the STEP IN switch is pressed, the head is continuously stepped in until it arrives at TRK79.</p>										
4	Motor Rotation	<p>1. Insert the 50 Auto disk and then MOTOR ON switch on.</p> <p>2. The motor rotates. (The INDEX indicator on the MFD Function Checker II blinks.)</p> <p>3. The W RTPRT and DSKCHG indicators light.</p>										
5	CHGRST	<p>1. The DSKCHG indicator goes out for MP-F17W-50L when the CHGRST switch is pressed.</p> <p>2. The DSKCHG indicator goes out for MP-F17W-50D when the STEP IN (OUT) switch is pressed.</p>										
6	Motor speed	1. The Motor speed can be measured at TRK35, on TP-3 of MFD Function Checker II with an universal counter. It should be 200msec±3.0msec.										

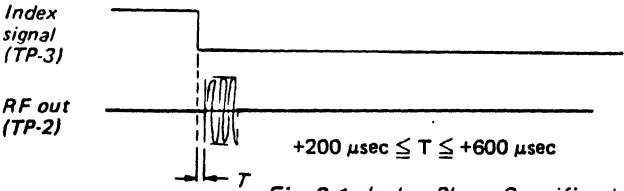
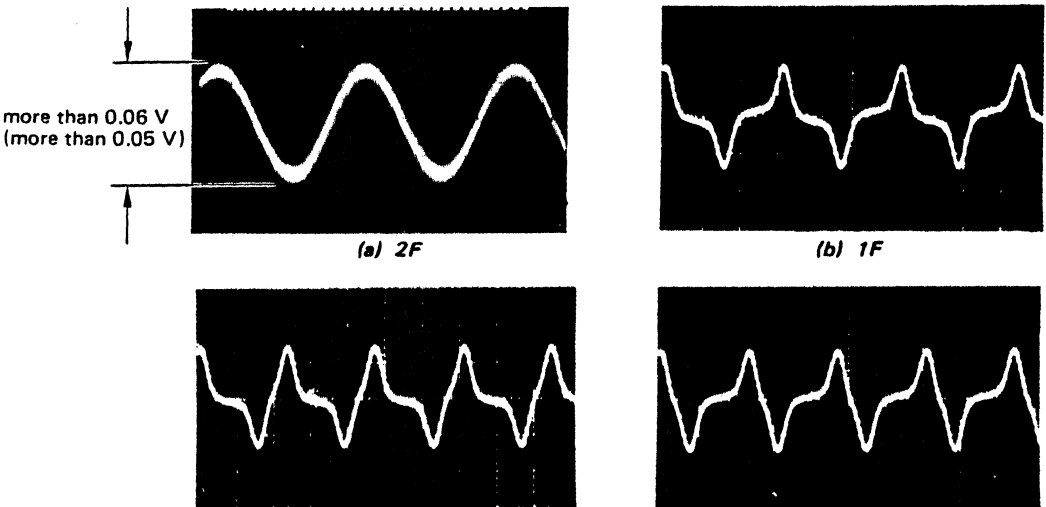
Procedure	Step	Operation
7	Index position	<p>1. Connect the CH-1 and CH-2 probes of oscilloscope to TP-2 of IF Board 52/53 and TP-3 of MFD Function Checker II. The oscilloscope is triggered by CH-2.</p> <p>2. Set the HDSL switch to side 0.</p> <p>3. The following waveform can be obtained on TRK 40.</p> <p>Note: The horizontal range is 200 μsec/div. The trigger phase is minus.</p>  <p style="text-align: center;">Fig. 3-1 Index Phase Specification</p> <p>4. Set the HDSL switch to side 1.</p> <p>5. The waveform in Fig. 3-1 can be obtained on TRK 40.</p>
8	Cassette out	<p>1. The DSKCHG indicator lights when the 50 Auto disk is ejected.</p>
9	Write	<p>1. Set the SW16 switch to 500 (250) side and then insert the HD Level disk (Level disk).</p> <p>2. Set the HDSL switch to side 0.</p> <p>3. Move head until it arrives at TRK 79.</p> <p>4. When the WRITE switch is pressed and "2F", "1F", "M" or "W" are written, the corresponding waveform can be obtained at TP-2 on IF Board 52/53. (Refer to Fig. 3-2)</p> <p>5. Set the HDSL switch to side 1, and "2F", "1F", "M" or "W" are written, the corresponding waveform can be obtained at TP-2 on IF Board 52/53. (Refer to Fig. 3-2)</p>  <p style="text-align: center;">Fig. 3-2 2F, 1F, M, W Signal Waveforms</p>

Procedure	Step	Operation
10	Output level	<ol style="list-style-type: none"> 1. Set the SW16 switch to 500 (250) side and then insert the HD Level disk (Level disk). 2. Set the HDSL switch to side 0. 3. Write "2F". The output signal level is more than 0.06V (0.05V). (Refer to Fig. 3-2 (a)) 4. Set the HDSL switch to side 1. Write "2F". The output signal level is more than 0.06V (0.05V). (Refer to Fig. 3-2 (a))
11	Peak Shift	<ol style="list-style-type: none"> 1. Set the SW16 switch to 500 (250) side and then insert the HD Level disk (Level disk). 2. Set the oscilloscope to only "CH-2" mode. 3. Change the CH-2 probe location of the oscilloscope from TP-3 on MFD Function Checker II to TP-4. 4. Set the HDSL switch to side 0. 5. Write "M" or "W" onto TRK79. Such waveform as shown in Fig. 3-3 can be obtained at TP-4 on MFD Function Checker II. The waveform in Fig. 3-3 shows the read data. <div data-bbox="730 987 1193 1260" style="text-align: center;"> <p style="text-align: center;">less than 2.45 μsec (less than 4.85 μsec)</p> </div> <p style="text-align: center;"><i>Fig. 3-3 Waveform of RD Data</i></p> <ol style="list-style-type: none"> 6. Set the HDSL switch to side 1. 7. Repeat item 5.
12	Track positioning	<ol style="list-style-type: none"> 1. Eject the HD Level disk (Level disk) and then insert the 50 Auto disk. 2. Return the CH-2 probe location of the TP-4 (RDDATA) on MFD Function Checker II to TP-3 (INDEX). 3. Set the HDSL switch to side 0. 4. Such a Cat's eye pattern signal as shown in Fig. 3-4 (a) can be obtained when the head accesses TRK00, 22, 27, 31, 36, 40, 45, 49, 54, 58, 63 or 79. The oscilloscope is triggered by CH-2. <p>Note: Such a signal as shown in Fig. 3-4 (b) can be obtained when the head accesses TRK40.</p> <ol style="list-style-type: none"> 5. Set the HDSL switch to side 1. Such a Cat's eye pattern signal as shown Fig. 3-4 (b) can be obtained when the head accesses TRK40. 6. Set the HDSL switch to side 0 again. 7. Move the head onto TRK40.

Procedure	Step	Operation
		<p>8. Set amplitude L in Fig. 3-4 (b) to 4 divisions, and then read amplitude R in Fig. 3-4 (b).</p> <p>Calculate the OFF TRACK value, referring to Table 3-1, in accordance with R in Fig. 3-4 (b).</p> <p>Then, obtain the humidity-compensated OFF TRACK value from the following expression:</p> <p>The compensated OFF TRACK value = OFF TRACK value + 0.2(50-H)(32-1.5S)/33.5(1)</p> <p>Where; H: Relative humidity (%) S: Side Side0= 0 Side1= 1</p> <p>The compensated OFF TRACK value should meet the following formula.</p> <p>-26 ≤ compensated OFF TRACK value ≤ +26...(2)</p>

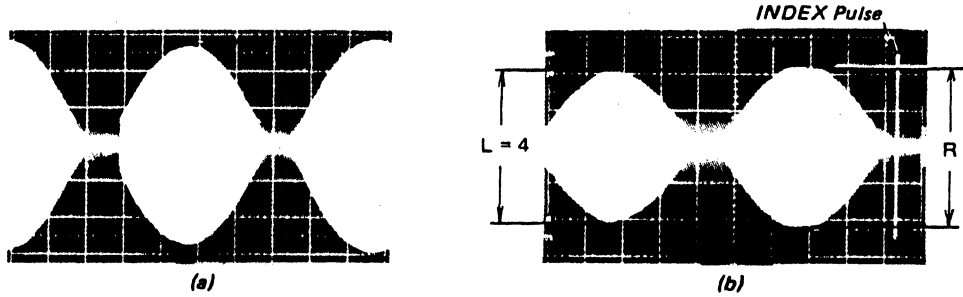

Fig. 3-4 Cat's eye Pattern Signal

(EX) For R = 3.6 in the MP-F17W-50D, the apparent OFF TRACK value is as shown in table 3-1.

Assuming the apparent OFF TRACK = 4.5, H = 60%, and S = 0, we can obtain the compensated OFF TRACK value as 2.589 from expression (1). This satisfy the formula.

	0.0	0.1	0.2	0.3	0.4	0.5	0.6	0.7	0.8	0.9
2:	28.7	28.8	25.0	23.2	21.5	19.8	18.2	16.7	15.2	13.7
3:	12.3	10.9	9.8	8.2	7.0	5.7	4.5	3.4	2.2	1.1
4:	0.0	-1.1	-2.1	-3.1	-4.1	-5.1	-6.0	-6.9	-7.8	-8.7
5:	-9.8	-10.4	-11.2	-12.0	-12.8	-13.6	-14.3	-15.1	-15.8	-16.5
6:	-17.2	-17.9	-18.5	-19.2	-19.8	-20.5	-21.1	-21.7	-22.3	-22.9
7:	-23.5	-24.0	-24.6	-25.1	-25.6	-26.2	-26.7	-27.2	-27.7	-28.2
8:	-28.7	-29.1	-29.6	-30.1	-30.5	-31.0	-31.4	-31.8	-32.2	-32.7
9:	-33.1	-33.5	-33.9	-34.3	-34.7	-35.0	-35.4	-35.8	-36.1	-36.5

Table 3-1

- Set the HDSL switch to the side 1.
- Repeat item 8.

13	TRK00 sensor level	<ol style="list-style-type: none"> Connect the CH-1 probe of oscilloscope to TP-1 (TRK 0) on IF Board 52/53 and CH-2 probe to TP-11 (TRG) on MFD Function Checker II. The oscilloscope is triggered by CH-2 (TRG).
----	--------------------	--

Procedure	Step	Operation
		<p>3. Move the head onto TRK01.</p> <p>4. Set the TRACK 00 ADJUST switch to on.</p> <p>5. At 2.6msec after triggered point, the voltage of the rising waveform must be more than 2.6V and that of the falling waveform must be less than 0.6V, as shown in Fig. 3-5.</p> <div data-bbox="711 562 1177 892" data-label="Figure"> </div> <p><i>Fig. 3-5 TRK00 Sensor Level</i></p>

3-3-2 Check Points to Abnormal Operation

Step	Abnormal Operation for each step	Check Point (defective place)	Normal Status
Power On	1. The Disk Motor rotates.	1. Disk Motor system.	The both signals of IC101-63 (XCIN) and IC101-27 (XMON) are High level.
Drive Select	1. The I/F indicators are put out for the selected combination, or they are lit for the unselected combination.	1. Drive Select circuit system. 2. IC101	The signal of IC101-28 (XSEL) is Low level. The signal of IC101-35 (XLED) and CN1-3 (XLEDON) are low level.
Stepping	1. TRK00 indicator does not light, when the head is located on TRK00.	1. TRK00 sensing circuit.	IC101-9 (XCT0) is Low level, when the head is set to TRK00.
	2. The step operation does not function at all, or it is not smoothly functioned.	1. Stepping motor drive system or stepping motor itself. 2. IC103	The signal of IC103-13 is Low level during step operation. The both signals of CN102-1 and CN102-2 are High or Low level.
Motor Rotation	1. The disk motor does not rotate.	1. Disk motor drive system.	IC1-12 is supplied clock (491KHZ). IC1-21 is supplied +5V. The signal of IC1-7 is Low level.
	2. Some I/F indicators do not light.	1. I/F signal circuit is defective.	
CHGRST	1. The DSKCHG indicator does not go out.	1. IC101	The signal of IC101-13 is Low level.
Motor Speed	1. Motor speed does not meet the specification.	1. X101	
	2. Motor speed is abnormally fast.	1. Disk motor drive system.	The pulse signal can be obtained at TP-4 (FG) on the Fixture-10.
Index Position	1. The shifted positions however do not meet the specification.	1. The index phase is mis-adjusted. (Refer to 5-3)	
	2. Offset value is 100μsec or more.	1. Head Carriage Ass'y. (Refer to 4-9)	
Cassette out	1. When the disk is ejected, the DSKCHG indicator does not light.	1. IC101 or S2	The signal of IC101-63 is High level and IC101-33 is Low level.

Step	Abnormal Operation for each step	Check Point (defective place)	Normal Status
Write	1. The waveform signal can not be re-written at both sides.	1. Write Circuit	During write operation, the both signals of IC101-22 and IC102-32 are Low level.
	2. The waveform signal can not be re-written at side 0 or side 1.	1. Write Circuit	During write operation at side 0, the signal of CN105-4 is 5V. During write operation at side 1, the signal of CN106-2 is 5V.
Output level	1. The output signal level does not meet the specification at both sides.	1. IC102	
	2. The output signal level does not meet the specification at side 0 or side 1.	1. Head Carriage Ass'y (Refer to 4-9)	
Peak Shift	1. The shifted peak value does not meet the specification.	1. Head Carriage Ass'y (Refer to 4-9)	
Track Positioning	1. The ratio of the left to right signals does not meet the specification or signal does not appear.	1. Radial alignment is incomplete. (Refer to 5-1) 2. A seek error has occurred.	
TRK00 Sensor level	1. The output signal does not meet the specification.	1. The TRK00 sensor positioning is improper. (Refer to 5-1)	

3-4 FINAL CHECK

3-4-1 Final Check for 1MByte Mode

3-4-1-1 Setting of SMC System

- a. Referring to Fig. 2-15, connect the drive to SMC system.
- b. Set the PORT SELECT switch of SMI-7016 to "ON". (Refer to Operating Instructions)
- c. Set the XADJ switch on the Fixture-10 to "OFF".
- d. Place AUTO START switch located on the left side panel to "DISK".

- e. Set the DRIVE SELECT switch (S101) of the unit to "3" (most left side).
- f. Insert the CP/M Disk into drive A.
- g. Turn on the power switch of SMC system. "A>" is displayed on screen.
- h. Set the MOTOR ON switch on IF Board 52/53 to "ON" and POWER SEL switch to "OFF".
- i. Eject the CP/M Disk and then insert the MFD System Disk.
- j. Perform keying **T E S T** and **RETURN**.

3-4-1-2 Set the Test Condition

Description	Keying	Display																		
To display original test condition of the drive.	T E S T	TEST Condition Test Mode 1.0M/300rpm Test Track 0 to 79																		
1. To change any of test condition.	F1	Command Table F1: Change Test Condition F2: F3: Read Test F4: Write Test																		
1-1. To change test mode of the drive.	F1	Set-Up Command F1: Change Test Mode F2: Change Test Track F3: Change Write Data																		
(EX)		<table border="1" style="width: 100%; text-align: center;"> <thead> <tr> <th></th> <th>F1</th> <th>F2</th> <th>F3</th> <th>F4</th> <th>F5</th> </tr> </thead> <tbody> <tr> <td>300rpm</td> <td>1.0M</td> <td>1.6M</td> <td>2.0M</td> <td>--</td> <td>--</td> </tr> <tr> <td>600rpm</td> <td>--</td> <td>--</td> <td>--</td> <td>--</td> <td>1.0M</td> </tr> </tbody> </table>		F1	F2	F3	F4	F5	300rpm	1.0M	1.6M	2.0M	--	--	600rpm	--	--	--	--	1.0M
	F1	F2	F3	F4	F5															
300rpm	1.0M	1.6M	2.0M	--	--															
600rpm	--	--	--	--	1.0M															
In case it is 1.0M/300rpm. (This control returns to command table.)	F1	TEST Condition Test Mode 1.0M/300rpm Test Track 0 to 79 Command Table F1: Change Test Condition F2: F3: Read Test F4: Write Test																		

Description	Keying	Display												
<p>2. To change any of test condition.</p> <p>2-1. To change test track of the disk.</p> <p>Type the minimum track to be tested. (EX) In case it is TRK00.</p> <p>Type the maximum track to be tested. (EX) In case it is TRK79. (This control returns to command table.)</p>	<p>F1</p> <p>F2</p> <p>0 RETURN</p> <p>7 9 RETURN</p>	<p>Set-Up Command</p> <p>F1: Change Mode F2: Change Test Track F3: Change Write Data</p> <p>Minimum track <u>0</u> Maximum track 79</p> <p>Minimum track 0 Maximum track <u>79</u></p> <p>TEST Condition</p> <p>Test Mode 1.0M/300rpm Test Track 0 to 79</p> <p>Command Table</p> <p>F1: Change Test Condition F2: F3: Read Test F4: Write Test</p>												
<p>3. To change any of test condition.</p> <p>3-1. To change the data pattern.</p> <p>(EX) In case it is DA pattern. (This control returns to command table.)</p>	<p>F1</p> <p>F3</p> <p>F1</p>	<p>Set-Up Command</p> <p>F1: Change Mode F2: Change Test Track F3: Change Write Data</p> <table border="0" data-bbox="873 1528 1349 1591"> <tr> <td></td> <td>F1</td> <td>F2</td> <td>F3</td> <td>F4</td> <td>F5</td> </tr> <tr> <td>Data</td> <td>DA</td> <td>DB6</td> <td>AA</td> <td>FF</td> <td>--</td> </tr> </table> <p>TEST Condition</p> <p>Test Mode 1.0M/300rpm Test Track 0 to 79</p> <p>Command Table</p> <p>F1: Change Test Condition F2: F3: Read Test F4: Write Test</p>		F1	F2	F3	F4	F5	Data	DA	DB6	AA	FF	--
	F1	F2	F3	F4	F5									
Data	DA	DB6	AA	FF	--									

3-4-1-3 Set the Read Operation

The test item from command table must be chosen.

Description	Keying	Display
To display original test condition of the drive.	T E S T	TEST Condition Test Mode 1.0M/300rpm Test Track 0 to 79
1. To read Dynamic Inspection Disk or prerecord data disk.	E3	Command Table F1: Change Test Condition F2: F3: Read Test F4: Write Test
(1) To change the pass count, hit E3 key in above menu. Type the number of pass count for reading track. (EX) In case it is 80 times. (all of tracks)	E3 8 0 RETURN	Read Test Pass count = 80 Track No. = 00 Side = 0 F1: Sequential F2: Random F3: Set pass count F5: Exit Select F1 -- F5
(2) Hit F1 or F2 key to start the Read test.	F1 or F2	Pass count =
Insert the Dynamic Inspection disk (OR-D51WA or OR-D52WA) and then hit RETURN key.	RETURN	Read Test Pass count = 80 Track No. = 00 Side = 0 F1: Sequential F2: Random F3: Set pass count F5: Exit Select F1 -- F5
		Disk ready --> Hit (Return) key. Pass count = Error count = 0

Description	Keying	Display
<p>The Read test ends.</p> <p>If the count number of error is 0, the read operation is ok.</p> <p>Note: If the HELP key is hit, test result (error track number, side number and sector number) will be displayed on the screen.</p>		Test End (hit any key)

3-4-1-4 Set the Write Operation

The test item from command table must be chosen.

Description	Keying	Display
<p>To display original test condition of the drive.</p>	T E S T	<p>TEST Condition</p> <p>Test Mode 1.0M/300rpm</p> <p>Test Track 0 to 79</p> <p>Command Table</p> <p>F1: Change Test Condition</p> <p>F2:</p> <p>F3: Read Test</p> <p>F4: Write Test</p>
<p>1. To write the data on a level disk.</p>	F4	<p>Write Test Pass count = 80</p> <p> Track No. = 00</p> <p> Side = 0</p> <p>F1: Sequential</p> <p>F2: Random</p> <p>F3: Set pass count</p> <p>F5: Exit</p> <p> Select F1 -- F5</p>
<p>(1) Hit the F1 or F2 key to start the Write test.</p> <p>Insert the level disk (OR-D46WA) and then hit RETURN key.</p> <p>The write test ends.</p> <p>If the count number of error is 0, the write operation is ok.</p> <p>Note: If the HELP key is hit, test result (error track number, side number and sector number) will be displayed on the screen.</p>	<p>F1 or F2</p> <p>RETURN</p>	<p>Disk ready --> Hit (Return) key.</p> <p>Pass count =</p> <p>Error count = 0</p> <p>Test End (hit any key)</p>

3-4-2 Final Check for 2MByte Mode

3-4-2-1 Setting of SMC System

- a. Referring to Fig. 2-15, connect the drive to SMC system.
- b. Set the PORT SELECT switch of SMI-7016 to "ON". (Refer to Operating Instructions)
- c. Set the XADJ switch on the Fixture-10 to "OFF".
- d. Place AUTO START switch located on the left side panel to "DISK".
- e. Set the DRIVE SELECT switch (S101) of the unit to "3" (most left side).

- f. Insert the CP/M Disk into drive A.
- g. Turn on the power switch of SMC system. "A>" is displayed on screen.
- h. Set the MOTOR ON switch on IF Board 52/53 to "ON" and POWER SEL switch to "OFF".
- i. Eject the CP/M Disk and then insert the MED System Disk.
- j. Perform keying **T E S T** and **RETURN**.

3-4-2-2 Set the Test Condition

Description	Keying	Display																		
To display original test condition of the drive.	T E S T	TEST Condition Test Mode 1.0M/300rpm Test Track 0 to 79 Command Table F1: Change Test Condition F2: F3: Read Test F4: Write Test																		
1. To change any of test condition.	F1	Set-Up Command F1: Change Test Mode F2: Change Test Track F3: Change Write Data																		
1-1. To change test mode of the drive. (EX) In case it is 2.0M/300rpm. (This control returns to command table.)	F1 F3	<table border="0" style="width: 100%; text-align: center;"> <tr> <td></td> <td>F1</td> <td>F2</td> <td>F3</td> <td>F4</td> <td>F5</td> </tr> <tr> <td>300rpm</td> <td>1.0M</td> <td>1.6M</td> <td>2.0M</td> <td>--</td> <td>--</td> </tr> <tr> <td>600rpm</td> <td>--</td> <td>--</td> <td>--</td> <td>--</td> <td>1.0M</td> </tr> </table> TEST Condition Test Mode 2.0M/300rpm Test Track 0 to 79		F1	F2	F3	F4	F5	300rpm	1.0M	1.6M	2.0M	--	--	600rpm	--	--	--	--	1.0M
	F1	F2	F3	F4	F5															
300rpm	1.0M	1.6M	2.0M	--	--															
600rpm	--	--	--	--	1.0M															
		Command Table F1: Change Test Condition F2: F3: Read Test F4: Write Test																		

Description	Keying	Display												
<p>2. To change any of test condition.</p> <p>2-1. To change test track of the disk.</p> <p>Type the minimum track to be tested. (EX) In case it is TRK00.</p> <p>Type the maximum track to be tested. (EX) In case it is TRK79. (This control returns to command table.)</p>	<p>F1</p> <p>F2</p> <p>0 RETURN</p> <p>7 9 RETURN</p>	<p>Set-Up Command</p> <p>F1: Change Mode F2: Change Test Track F3: Change Write Data</p> <p>Minimum track <u>0</u> Maximum track 79</p> <p>Minimum track 0 Maximum track <u>79</u></p> <p>TEST Condition</p> <p>Test Mode 2.0M/300rpm Test Track 0 to 79</p> <p>Command Table</p> <p>F1: Change Test Condition F2: F3: Read Test F4: Write Test</p>												
<p>3. To change any of test condition.</p> <p>3-1. To change the data pattern.</p> <p>(EX) In case it is DA pattern. (This control returns to command table.)</p>	<p>F1</p> <p>F3</p> <p>F1</p>	<p>Set-Up Command</p> <p>F1: Change Mode F2: Change Test Track F3: Change Write Data</p> <table border="0" data-bbox="868 1543 1339 1617"> <tr> <td></td> <td>F1</td> <td>F2</td> <td>F3</td> <td>F4</td> <td>F5</td> </tr> <tr> <td>Data</td> <td>DA</td> <td>DB6</td> <td>AA</td> <td>FF</td> <td>--</td> </tr> </table> <p>TEST Condition</p> <p>Test Mode 2.0M/300rpm Test Track 0 to 79</p> <p>Command Table</p> <p>F1: Change Test Condition F2: F3: Read Test F4: Write Test</p>		F1	F2	F3	F4	F5	Data	DA	DB6	AA	FF	--
	F1	F2	F3	F4	F5									
Data	DA	DB6	AA	FF	--									

3-4-2-3 Set the Read Operation

The test item from command table must be chosen.

Description	Keying	Display
<p>To display original test condition of the drive.</p>	<p>T E S T</p>	<p>TEST Condition Test Mode 2.0M/300rpm Test Track 0 to 79</p> <p>Command Table F1: Change Test Condition F2: F3: Read Test F4: Write Test</p>
<p>1. To read Dynamic Inspection Disk or prerecord data disk.</p>	<p>F3</p>	<p>Read Test Pass count = 80 Track No. = 00 Side = 0</p> <p>F1: Sequential F2: Random F3: Set pass count</p> <p>F5: Exit Select F1 -- F5</p>
<p>(1) To change the pass count, hit F3 key in above menu. Type the number of pass count for reading track. (EX)</p>	<p>F3</p>	<p>Pass count =</p>
<p>In case it is 80 times. (all of tracks)</p>	<p>8 0 RETURN</p>	<p>Read Test Pass count = 80 Track No. = 00 Side = 0</p> <p>F1: Sequential F2: Random F3: Set pass count</p> <p>F5: Exit Select F1 -- F5</p>
<p>(2) Hit F1 or F2 key to start the Read test.</p> <p>Insert the Dynamic Inspection disk (OR-D222WA or OR-D223WA) and then hit RETURN key.</p>	<p>F1 or F2 RETURN</p>	<p>Disk ready --> Hit (Return) key. Pass count = Error count = 0</p>

Description	Keying	Display
<p>The Read test ends.</p> <p>If the count number of error is 0, the read operation is ok.</p> <p>Note: If the HELP key is hit, test result (error track number, side number and sector number) will be displayed on the screen.</p>		<p>Test End (hit any key)</p>

3-4-2-4 Set the Write Operation

The test item from command table must be chosen.

Description	Keying	Display
<p>To display original test condition of the drive.</p> <p>1. To write the data on a HD level disk.</p> <p>(1) Hit the F1 or F2 key to start the Write test.</p> <p>Insert the HD level disk (OR-D206WA) and then hit RETURN key.</p> <p>The write test ends.</p> <p>If the count number of error is 0, the write operation is ok.</p> <p>Note: If the HELP key is hit, test result (error track number, side number and sector number) will be displayed on the screen.</p>	<p>T E S T</p> <p>F4</p> <p>F1 or F2</p> <p>RETURN</p>	<p>TEST Condition</p> <p>Test Mode 2.0M/300rpm</p> <p>Test Track 0 to 79</p> <p>Command Table</p> <p>F1: Change Test Condition</p> <p>F2:</p> <p>F3: Read Test</p> <p>F4: Write Test</p> <p>Write Test Pass count = 80</p> <p>Track No. = 00</p> <p>Side = 0</p> <p>F1: Sequential</p> <p>F2: Random</p> <p>F3: Set pass count</p> <p>F5: Exit</p> <p>Select F1 -- F5</p> <p>Disk ready --> Hit (Return) key.</p> <p>Pass count =</p> <p>Error count = 0</p> <p>Test End (hit any key)</p>

3-4-3 Error Message

ERROR MESSAGE	CONSIDERABLE CAUSE	COUNTERMEASURE (CONFIRMATION/ADJUSTMENT)
Record not found	1. Stepping motor circuit or stepping motor itself is out of order.	Confirm the function of stepping motor circuit or stepping motor itself.
	2. Read circuit is out of order.	Confirm the read circuit. (at first check RF output)
CRC error	1. Off track, chucking trouble, wrong head compliance.	Confirm head compliance (Refer to 5-2), chucking mechanism or radial alignment and TRK00 sensor (Refer to 5-1).
ID ADM missing	1. No write function. (write circuit is out of order, no formatting)	Confirm the waveform of RF output.
	2. Off track, wrong head compliance, chucking trouble, or disk.	Confirm the radial alignment and TRK00 sensor (Refer to 5-1), head compliance (Refer to 5-2), or chucking mechanism.
Write protect error	1. Condition is set to write protect.	Confirm Media, write protect circuit or write protect mechanism.
Drive not connected	1. Disk is not inserted, or the insertion is not detected.	Confirm disk detect circuit.
	2. DC power is not supplied, or a drive is not selected.	Confirm DC power supplier, drive select switch position and drive select circuit.

SECTION 4 PART REPLACEMENT

4-1 COVER ASS'Y REPLACEMENT

4-1-1 Removal

- a. Insert your finger into the rear right side portion of the Cover Ass'y as shown in Fig. 4-1, and dislocate the Cover Ass'y from the hook while applying some force to the direction marked with arrow. The whole Cover Ass'y can be taken out.

4-1-2 Installation

- a. Match the projection located in the front side of the Cover Ass'y with square hole of the front panel ass'y and then put the rear of the Cover Ass'y into the proper position. (Refer to Fig. 4-1)

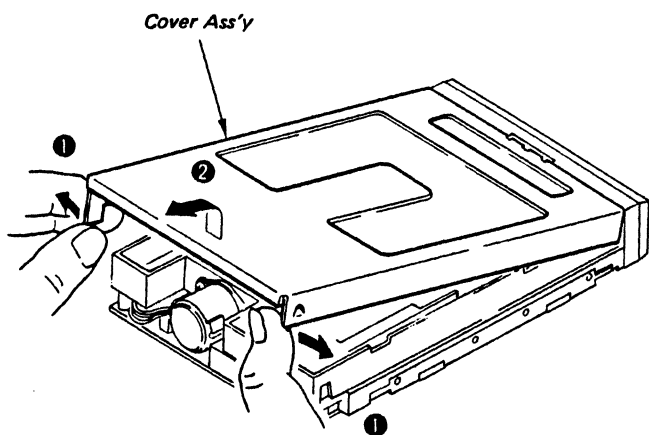

Fig. 4-1 Cover Ass'y Replacement

4-2 FRONT PANEL ASS'Y AND EJECT BUTTON REPLACEMENT

4-2-1 Removal

- a. Remove the cover ass'y. (Refer to 4-1)
- b. Push slightly the plastic hinges located on each of right and left sides with (-) shaped screw driver through the square hole of upper cover, and pull it slowly toward you. (Refer to Fig. 4-2)
- c. Dislocate the Eject Button from the hook of the slide plate.

4-2-2 Installation

- a. Hang the Eject Button to the hook of slide plate as shown Fig. 4-2.
- b. Install the Front Panel Ass'y into the metal frame by sliding in the hook located on each side of the Front Panel Ass'y.

- c. Make sure that protuberances of LED and the Eject Button are properly located in the recess and square hole of the Front Panel Ass'y.
- d. Install the cover ass'y. (Refer to 4-1)

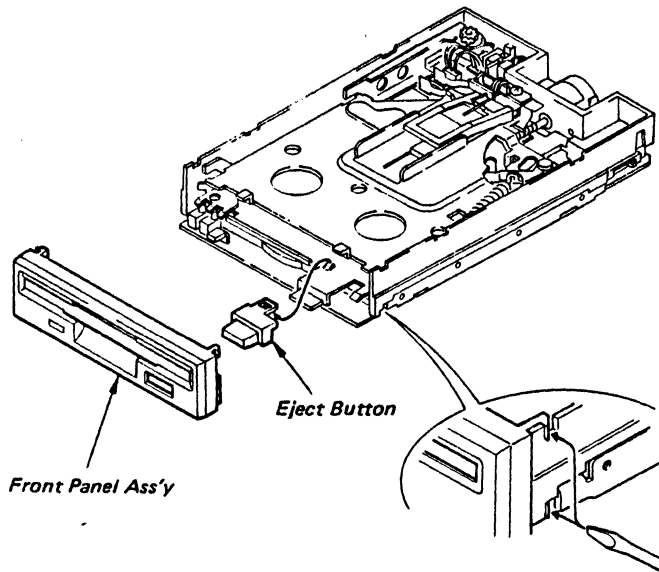

Fig. 4-2 Front Panel Ass'y Replacement

4-3 LG-2 MOUNTED BOARD REPLACEMENT

4-3-1 Removal

- a. Remove the cover ass'y. (Refer to 4-1)
- b. Disconnect the all connectors. (CN102 for stepping motor, CN104 for 00 sensor, CN105 and CN106 for head carriage ass'y)
- c. Desolder the jumper cable (CN1) on MT-2 mounted board with soldering iron.

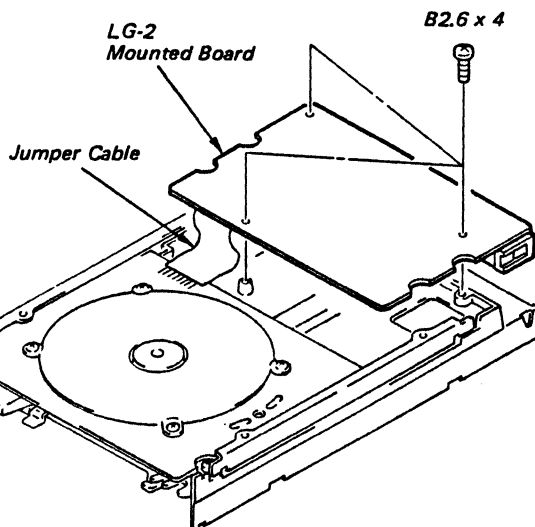

Fig. 4-3 LG-2 Mounted Board Replacement

- d. Remove the three screws (B2.6x4) securing the LG-2 Mounted Board and then remove the LG-2 Mounted Board. (Refer to Fig. 4-3)

4-3-2 Installation

- a. Solder the jumper cable to the CN1 of MT-2 mounted board.
- b. Install the LG-2 Mounted Board with three screws (B2.6x4).
- c. Connect the all connectors.
- d. Perform the Radial Alignment and TRK00 sensor Adjustment. (Refer to 5-1)
- e. Install the cover ass'y. (Refer to 4-1)

4-4 MT-2 MOUNTED BOARD REPLACEMENT

4-4-1 Removal

- a. Desolder the jumper cable on MT-2 Mounted Board with soldering iron.
- b. Remove the four screws (P2.6x4) securing the Stator Yoke Ass'y and then remove the Stator Yoke Ass'y. (Refer to Fig. 4-4)
- c. Disconnect the connenctor CN2 (hall IC ass'y) and then remove the MT-2 Mounted Board.

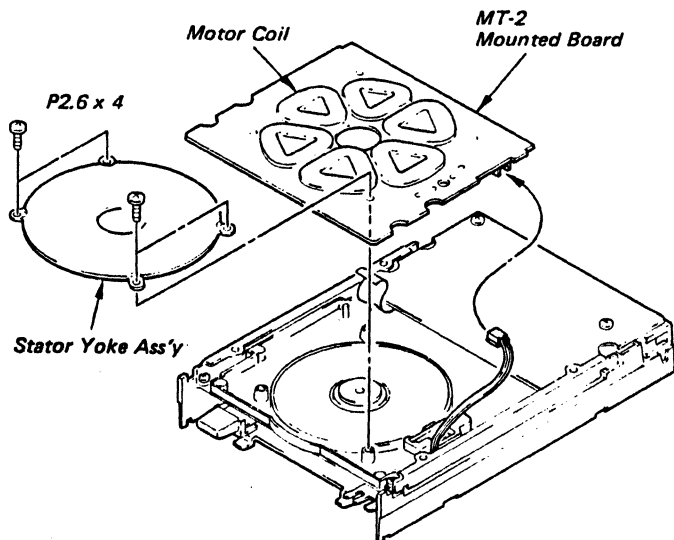

Fig. 4-4 MT-2 Mounted Board Replacement

4-4-2 Installation

- a. Connect the connector CN2 (hall IC ass'y) onto the MT-2 Mounted Board.
- b. Solder the Jumper Cable to CN1 of MT-2 Mounted Board.

- c. Match the hole of the MT-2 Mounted Board with the emboss of the chassis ass'y.
- d. Install the Stator Yoke Ass'y on MT-2 Mounted Board with four screws (P2.6x4), not to damage to six motor coils for disk motor. (Refer to Fig. 4-4)

4-5 HALL IC ASS'Y REPLACEMENT

4-5-1 Removal

- a. Remove the four screws (P2.6x4) securing the stator yoke ass'y and then remove the stator yoke ass'y. (Refer to Fig. 4-4)
- b. Disconnect the connector CN2 (Hall IC Ass'y).
- c. Remove the screw (PSW2x5/LR PSW2x5) securing the Hall IC Ass'y and then remove the Hall IC Ass'y. (Refer to Fig. 4-5)

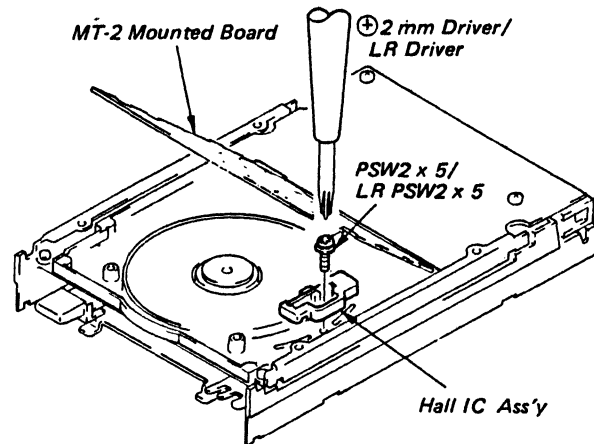

Fig. 4-5 Hall IC Ass'y Replacement

4-5-2 Installation

- a. Fasten loosely the Hall IC Ass'y with a screw (PSW2x5/LR PSW2x5). But this screw must not be tightened for later adjustment.
- b. Connect the connector CN2 (Hall IC Ass'y) onto the MT-2 mounted board.
- c. Match the hole of the MT-2 mounted board with the emboss of the chassis ass'y.
- d. Install the stator yoke ass'y on MT-2 mounted board with four screws (P2.6x4), not to damage to six motor coils for disk motor. (Refer to Fig. 4-4)
- e. Perform the Index phase adjustment. (Refer to 5-3)

4-6 CASSETTE HOLDER ASS'Y REPLACEMENT

4-6-1 Removal

- Connect the drive to the MFD Function Checker II (Refer to Fig. 2-14), move the head to the TRK00 and then disconnect the drive from MFD Function Checker II.
- Remove the cover ass'y. (Refer to 4-1)
- Remove the front panel ass'y and eject button. (Refer to 4-2)
- Be careful not to apply the excessive force to the head carriage ass'y. While pushing the eject lever, take the Cassette Holder Ass'y. (Refer to Fig. 4-6)

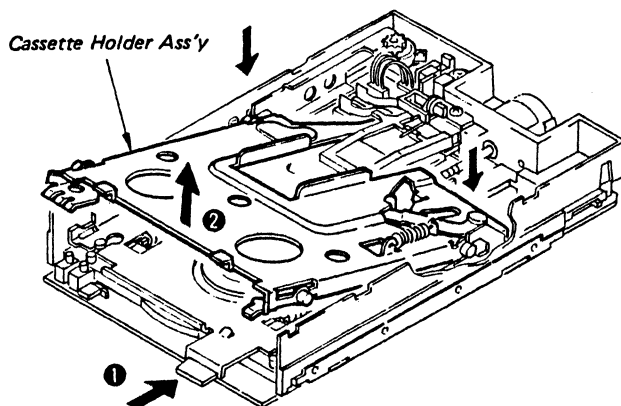

Fig. 4-6 Cassette Holder Ass'y Replacement

4-6-2 Installation

- Insert carefully the Cassette Holder Ass'y underneath the arm of the head carriage ass'y, then set the holder into the location shown by arrow as shown in Fig. 4-6, while pushing the eject lever.
- Install the front panel ass'y and eject button. (Refer to 4-2)
- Install the cover ass'y. (Refer to 4-1)

4-7 SLIDE PLATE ASS'Y REPLACEMENT

4-7-1 Removal

- Remove the cover ass'y. (Refer to 4-1)
- Remove the front panel ass'y and eject button. (Refer to 4-2)
- Remove the cassette holder ass'y. (Refer to 4-6)
- Slide the trigger arm to set the Disk In-mode as shown in Fig. 4-7.
- Remove the one end of Tension Springs on chassis ass'y and then take the Slide Plate Ass'y. (Refer to Fig. 4-7)

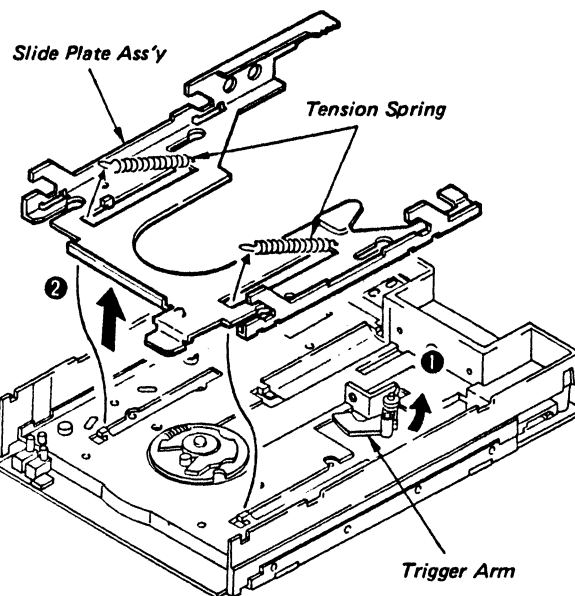

Fig. 4-7 Slide Plate Ass'y Replacement

4-7-2 Installation

- While pushing the trigger arm, set the Slide Plate Ass'y into the location shown in Fig. 4-7.
- Hang the Tension Springs on hook of chassis ass'y.
- Push the Slide Plate Ass'y, while pushing the trigger arm back side. (This stays "disk-in mode")
- Install the cassette holder ass'y. (Refer to 4-6)
- Install the front panel ass'y and eject button. (Refer to 4-2)
- Install the cover ass'y. (Refer to 4-1)
- Make the head clean. (Refer to 5-4)

4-8 00 SENSOR REPLACEMENT

4-8-1 Removal

- Connect the drive to the MFD Function Checker II as shown in Fig. 2-14, move the head to TRK79 and then disconnect the drive from the MFD Function Checker II.
- Remove the cover ass'y. (Refer to 4-1)
- Disconnect the connector CN104 (00 Sensor) from the LG-2 mounted board.
- Remove the screw (PSW2.6x6) securing the 00 Sensor and remove 00 Sensor. (Refer to Fig. 4-8)

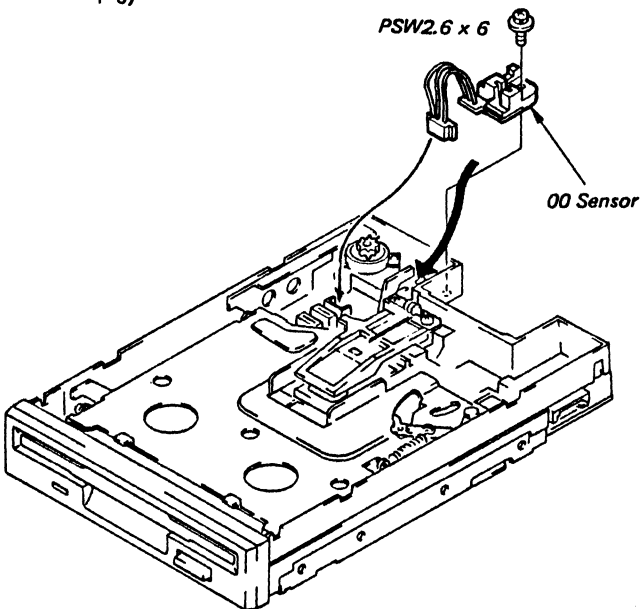

Fig. 4-8 00 Sensor Replacement

4-8-2 Installation

- Install the 00 Sensor with a screw (PSW2.6x6).
- Connect the CN104 connector onto the LG-2 mounted board.
- Perform the radial alignment and TRK00 sensor adjustment. (Refer to 5-1)
- Install the cover ass'y. (Refer to 4-1)

4-9 HEAD CARRIAGE ASS'Y REPLACEMENT

4-9-1 Removal

- Remove the cover ass'y. (Refer to 4-1)
- Remove the front panel ass'y and eject button. (Refer to 4-2)
- Remove the cassette holder ass'y. (Refer to 4-6)

- Disconnect the connectors CN105 and CN106 (flexible boards) from the LG-2 mounted board.
- Remove the screw (P2.6x4) securing the Guide Retainer and then remove the Guide Retainer, Head Carriage Ass'y and Slide Guide Shaft. (Refer to Fig. 4-9)

4-9-2 Installation

Note: Apply Sony oil to the Guide Shaft before installation. Apply Sony oil to the openings of Head Carriage Ass'y using the bamboo stick.

- Pass the Guide Shaft through the opening of Head Carriage Ass'y.

Note: The spring of Head Carriage Ass'y, that is located in around shaft hole, should be installed inside so that the Guide Shaft is forced outwardly by the spring force, as shown in Fig. 4-9.

- Put the Head Carriage Ass'y and the Slide Guide Shaft in place, and install the guide retainer with a screw (P2.6x4).
- Connect the flexible boards to CN105 and CN106 on the LG-2 mounted board.

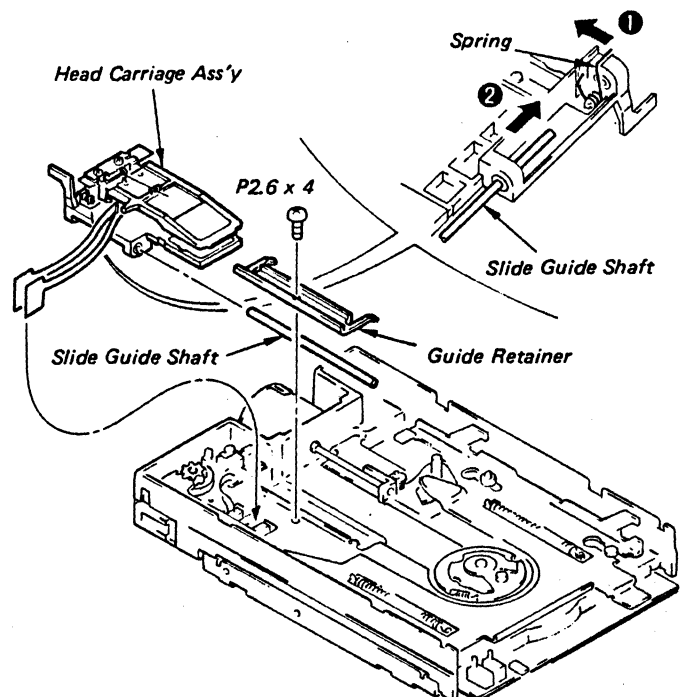

Fig. 4-9 Head Carriage Ass'y Replacement

- d. Install the cassette holder ass'y. (Refer to 4-6)
- e. Install the front panel ass'y and eject button. (Refer to 4-2)
- f. Perform the radial alignment and TRK00 sensor adjustment. (Refer to 5-1)
- g. Perform the head compliance. (Refer to 5-2)
- h. Install the cover ass'y. (Refer to 4-1)
- i. Make the head clean. (Refer to 5-4)

4-10 STEPPING MOTOR ASS'Y (ROTOR ASS'Y AND STATOR ASS'Y) REPLACEMENT

4-10-1 Removal

- a. Remove the cover ass'y. (Refer to 4-1)
- b. Remove the front panel ass'y and eject button. (Refer to 4-2)
- c. Remove the cassette holder ass'y. (Refer to 4-6)
- d. Disconnect the connector CN102 (Stator Ass'y) from the LG-2 mounted board.
- e. Remove the three screws (B2.6x4) securing LG-2 mounted board so that removal of Stator Ass'y can be easily performed.
- f. Remove the two screws (PSW2.6x5) securing the Stator Ass'y and then remove the Stator Ass'y and steel ball. (Refer to Fig. 4-10)
- g. Wipe away the grease applied around lead screw with soft cloth before removal of Stator Ass'y and Rotor Ass'y, not to leave the grease in the chassy hole during the removal.

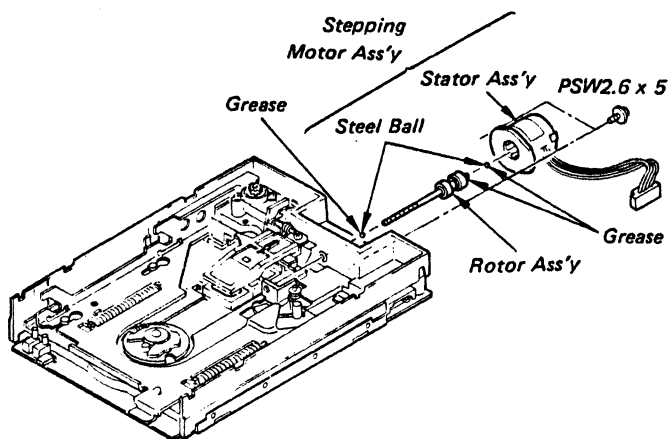

Fig. 4-10 Stepping Motor Ass'y (Stator Ass'y and Rotor Ass'y) Replacement

- h. While twisting Rotor Ass'y, separate the Rotor Ass'y from the needle pin of head carriage ass'y.
- i. Take the steel ball from the hole of chassis ass'y.

4-10-2 Installation

Note: The stepping motor must be replaced with the whole ass'y, since the wrong combination (Rotor Ass'y and Stator Ass'y) in the ass'y causes the malfunction.

Note: Apply Molykote Grease (EM10L) (same quantity of match tip) on whole area of lead screw and two steel balls before the installation.

- a. Insert the steel ball into hole of the chassis ass'y.
- b. While lifting the head carriage ass'y a little, insert the lead screw of the Rotor Ass'y between the needle and plate spring of head carriage ass'y.
- c. Insert the steel ball into hole of Rotor Ass'y.
- d. Fasten loosely the Stator Ass'y with two screws (PSW2.6x5). But these screws must not be tightened for later adjustment.
- e. Connect the connector CN102 (Rotor Ass'y) onto the LG-2 mounted board.
- f. Install the cassette holder ass'y. (Refer to 4-6)
- g. Install the front panel ass'y and eject button. (Refer to 4-2)
- h. Perform the radial alignment and TRK00 sensor adjustment. (Refer to 5-1)
- i. Install the cover ass'y. (Refer to 4-1)
- j. Make the head clean. (Refer to 5-4)

4-11 OIL DAMPER REPLACEMENT

4-11-1 Removal

- a. Remove the cover ass'y. (Refer to 4-1)
- b. Remove one screw (P2x5) securing the Damper to chassy ass'y.
- c. Lift up the Damper and take it out. (Refer to Fig. 4-11)

4-11-2 Installation

- a. Insert one end of the Damper (small hole) into the boss.

- b. Align the Damper gear with the teeth portion of the slide plate ass'y.
- c. Secure the Damper with the screw (P2x5).

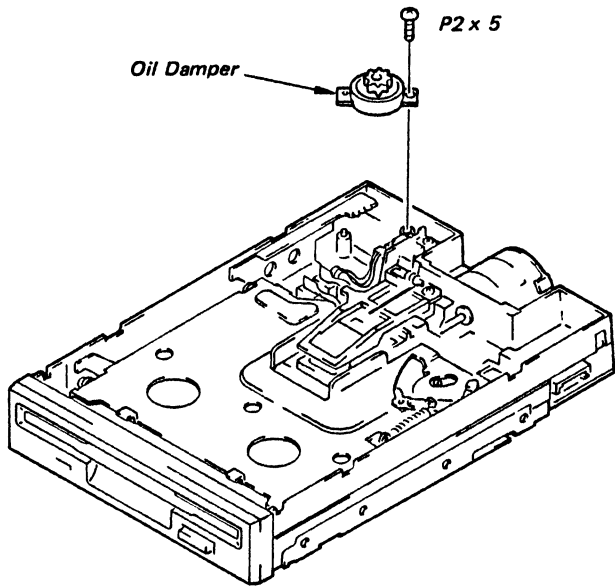

Fig. 4-11 Oil Damper Replacement

4-12 COMBINATION OF HEAD CARRIAGE ASS'Y AND LG-2 MOUNTED BOARD

This drive has two types of combination, consisting of Head Carriage Ass'y and LG-2 Mounted Board. We call them as "high current type" and "low current type" for easy reference. The combination must not be mixed up, otherwise the unit may not satisfy the original specification.

- a. "High current type"

Marking on Head Carriage Ass'y

The letter must be "Q" in the first wording on the ass'y.

Parts No.; A-8010-249-A

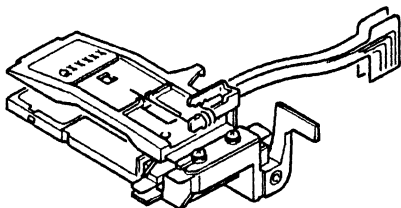

Setting of SH101

If SH101 is not shorted with soldering, short SH101 with a soldering. As the result, R178 (33K) is connected in parallel to other resistors R155/R156.

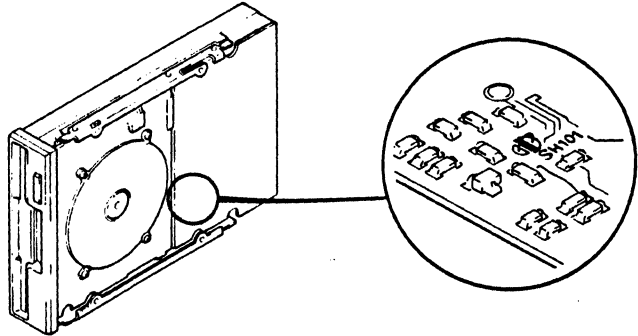

- b. "Low current type"

Marking on Head Carriage Ass'y

The letter must be "P" in the first wording on the ass'y.

Parts No.; A-8010-248-A

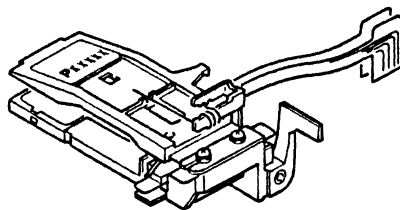

Setting of SH101

If SH101 is shorted with soldering, remove soldering. As the result, R178 (33K) is disconnected.

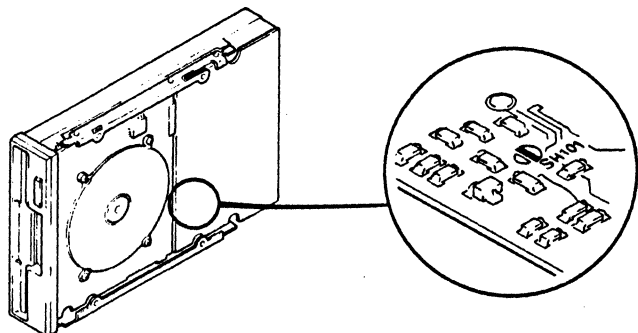

SECTION 5 CHECK AND ADJUSTMENT

5-1 RADIAL ALIGNMENT AND TRK00 SENSOR

Disassemble the following parts and then perform the measurement and adjustment.

a. Cover Ass'y (Refer to 4-1)

5-1-1 Tools and Measuring Equipment

- a. SMC System
- b. MFD System Disk (OR-D176VA)
- c. 50 Auto Disk (OR-D157WA)
- d. CP/M Disk
- e. TRK00 Adj. Lever.
- f. Radial Alignment Adj. Driver
- g. Torque Driver
- h. Digitizer
- i. Fixture-10
- j. IF Board 52/53
- k. Conversion Cable (01) only for MP-F17W-50D

5-1-2 Initial Setting

- a. Install the TRK00 Adj. Lever onto Fixture-10.
(Refer to 2-2-4)

b. Connect the system as shown in Fig. 2-16.

c. Insert the CP/M Disk into the SMC System.

d. Turn on the power switch. "A>" is displayed on screen.

e. Eject the CP/M Disk and then insert the MFD system disk.



f. Perform keying **A** **D** **6** **3** and **RETURN** .

g. Connect the disk drive (under test) to the cable which leads to the IF board 52/53, insert the 50 Auto Disk, and set the DRIVE SELECT switch (S101) to 0 (most right side). (Refer to Fig. 2-16)

h. The set-up command is automatically setted.

Note: For resuming the state of SMC system to the initial state (that appears immediately after power goes on) press the reset button.

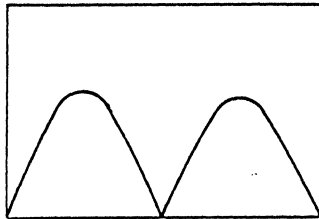
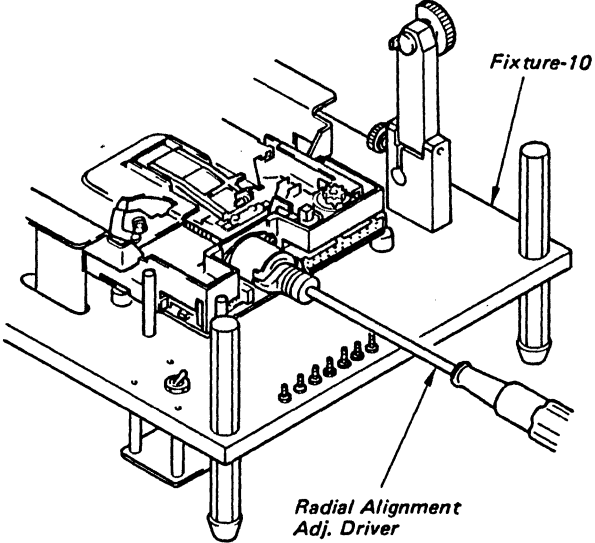
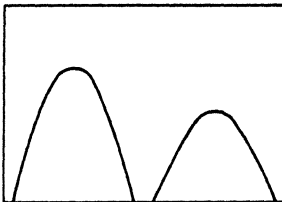
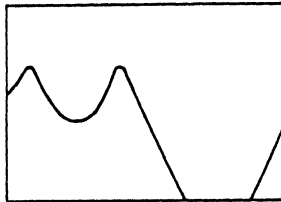
Function	Keying	Display
		<pre> === SET UP MENU === [1] HUMIDITY : 50 [%] [2] OFF TRACK : 26 [μm] [3] Exit </pre>
<p>1. The initial value for the humidity is to be set at 50%.</p> <p>(EX)</p> <p>In case the humidity of 60% is keyed in,</p>	<p>1</p>	<p>(1) HUMIDITY..... :</p>
<p>2. The initial value for the specified off track is to be set at 26μm.</p> <p>(EX)</p> <p>In case an off track of 30μm is keyed in,</p>	<p>6 0</p> <p>RETURN</p> <p>2</p>	<p>(2) OFF TRACK :</p>
<p>3. After the SET UP ends, the drive under test is set in the Fixture-10 and 34 pin connector and power connector are connected to the drive, hit the 3 key.</p>	<p>3 0</p> <p>RETURN</p> <p>3</p>	<p>Turn on the power of IF board.</p>
<p>Note: This will start the adjustment.</p> <p>4. Set POWER SEL switch to "OFF" side (D1/D2 indicators do not light.) and then turn on the power.</p>	<p>RETURN</p>	<p>Set XADJ SW to OFF.</p>

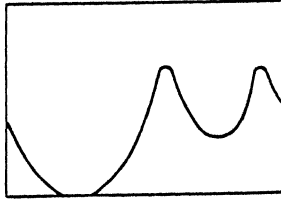
Function	Keying	Display
5. Set XADJ SW to "OFF" side.	RETURN	Set MOTOR ON SW to ON and insert Alignment Disk.
6. Insert a 50 Auto disk, and turn the MOTOR ON switch of IF Board 52/53 off and then on.		Set XADJ SW to ON.
7. Set XADJ switch to "ON" side.	RETURN	=== PRE ADJUSTMENT ===
8. Turn the stepping motor with the Radial Alignment Adj. driver as shown in Fig. 5-1 (b) until the amplitude ratio of left and right peaks becomes equal. (Refer to Fig. 5-1 (a))		 <p style="text-align: center;">Fig. 5-1 (a)</p>
<p>Note: When the ratio of left and right peaks is within the specification, wave lines become red color.</p>		 <p style="text-align: center;">Fig. 5-1 (b) Radial Alignment Adjustment</p>
9. When the adjustment does not satisfy the specification (wave lines do not become red color), move the head innerwards or outerwards by pushing the arrow key -> or <- .		 <p style="text-align: center;">Fig. 5-1 (c)</p>
<p>Note: <- move the head innerward.</p>		 <p style="text-align: center;">Fig. 5-1 (d)</p>
<p>Note: -> move the head outward.</p>		
<p>Note: If adjustment of the stepping motor cannot be conducted, first find the appropriate position in accordance with the followings, and perform the adjustment again.</p>		
(1) When the cat's eye pattern is similar to Fig. 5-1 (c) or (d), turn the Radial Alignment adj. driver clockwise.		
(2) When the cat's eye pattern is similar to Fig. 5-1 (e) or (f), turn the Radial Alignment Adj. driver counterclockwise.		
10. Hit RETURN key.	RETURN	
<p>Note: Unless the wave line becomes red color, the next step cannot be executed even if RETURN key is depressed.</p>		 <p style="text-align: center;">Fig. 5-1 (e)</p>
		 <p style="text-align: center;">Fig. 5-1 (f)</p>

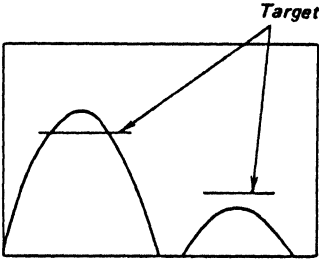
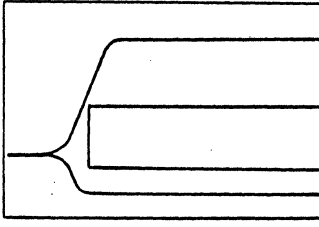
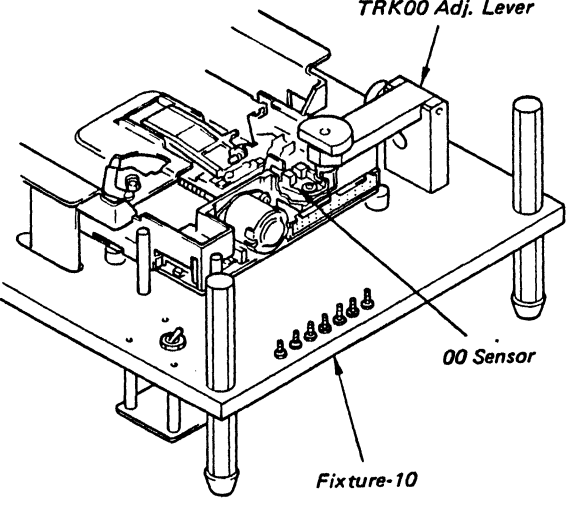
Function	Keying	Display
<p>11. The off track value of TRK00 to TRK79 is being measured, and then the calculation is completed.</p> <p>The maximum and minimum off track values are displayed.</p>		<p>Max=x.x Min=x.x</p> 
<p>12. The RF signals on adjustment tracks and two target lines are simultaneously displayed on screen.</p> <p>Turn the stepping motor with the Radial Alignment Adj. driver until the peak points of the cat's eye pattern reach the target line. (Refer to Fig. 5-1 (g))</p>		<p><i>Fig. 5-1 (g)</i></p> 
<p>Note: At the point of correct adjustment, the color of target lines becomes red.</p>		<p><i>Fig. 5-1 (h) TRK00 Sensor Level</i></p>
<p>Note: Unless the stepping motor is located at the point of the correct adjustment, the next step cannot be executed even if RETURN key is depressed.</p>		
<p>13. Tighten the two screws securing the stepping motor by the torque driver with the torque force of 3.5Kg-cm.</p>		<p><i>Fig. 5-1 (i) TRK00 Sensor Level Adjustment</i></p>
<p>14. The adjustment of TRK00 sensor level is executed.</p>	<p>RETURN</p>	<p>Set XADJ SW to OFF.</p>
<p>15. The TRK00 sensor level is displayed.</p> <p>Loose the screw securing the 00 Sensor, and move the board by the TRK00 Adj Lever so that the upper or lower lines does not cross the red lines marked. (Refer to Fig. 5-1 (h), (i))</p> <p>Tighten the screw securing the 00 Sensor.</p>		<p>RETURN</p>
<p>16. Hit RETURN key.</p> <p>Note: Unless the location of the 00 sensor is properly settled, the next step cannot be executed even if RETURN key is depressed.</p>	<p>RETURN</p>	<p>RETURN</p>
<p>17. Set the XADJ switch of Fixture-10 to "OFF" side.</p>	<p>RETURN</p>	

Function	Keying	Display
<p>18. The status of PS101 may need changing. If so the display prompts. Follow the flowchart "How to change step motor phase" on page 45.</p> <p>If the status of link PS101 is OK, no prompt is displayed and final alignment test is done (step 19).</p> <p>(a) Hit <input type="text" value="RETURN"/> key.</p> <p>(b) Set POWER SEL switch to "OFF" side and then turn on the power.</p> <p>(c) Set XADJ SW to "OFF" side.</p> <p>(d) Insert a 50 Auto disk, and turn the MOTOR ON switch of IF Board 52/53 off and then on.</p>	<p><input type="text" value="RETURN"/></p> <p><input type="text" value="RETURN"/></p> <p><input type="text" value="RETURN"/></p>	<p>Change IC Link condition.</p> <p>Turn on the power of IF board.</p> <p>Set XADJ SW to OFF.</p> <p>Set MOTOR ON SW to ON and insert Alignment Disk.</p>
<p>19. The off track value of TRK00 to TRK79 is being measured, and then the calculation is completed.</p> <p>The maximum and minimum off track values are displayed.</p>		<p>Max=x.x</p> <p>Min=x.x</p>
<p>20. If the adjustment is within the specification, the CRT screen is changed to green color.</p> <p>or</p> <p>If not, the CRT screen is changed to red color.</p>		
<p>21. To retry the adjustment, hit <input type="text" value="RETURN"/> key.</p> <p>or</p> <p>To terminate the adjustment, hit the key of <input type="text" value="E"/>.</p>	<p><input type="text" value="RETURN"/></p> <p>or</p> <p><input type="text" value="E"/></p>	<p>Turn on the power of IF board.</p> <p>A></p>

How to change the phase mode of stepping motor.

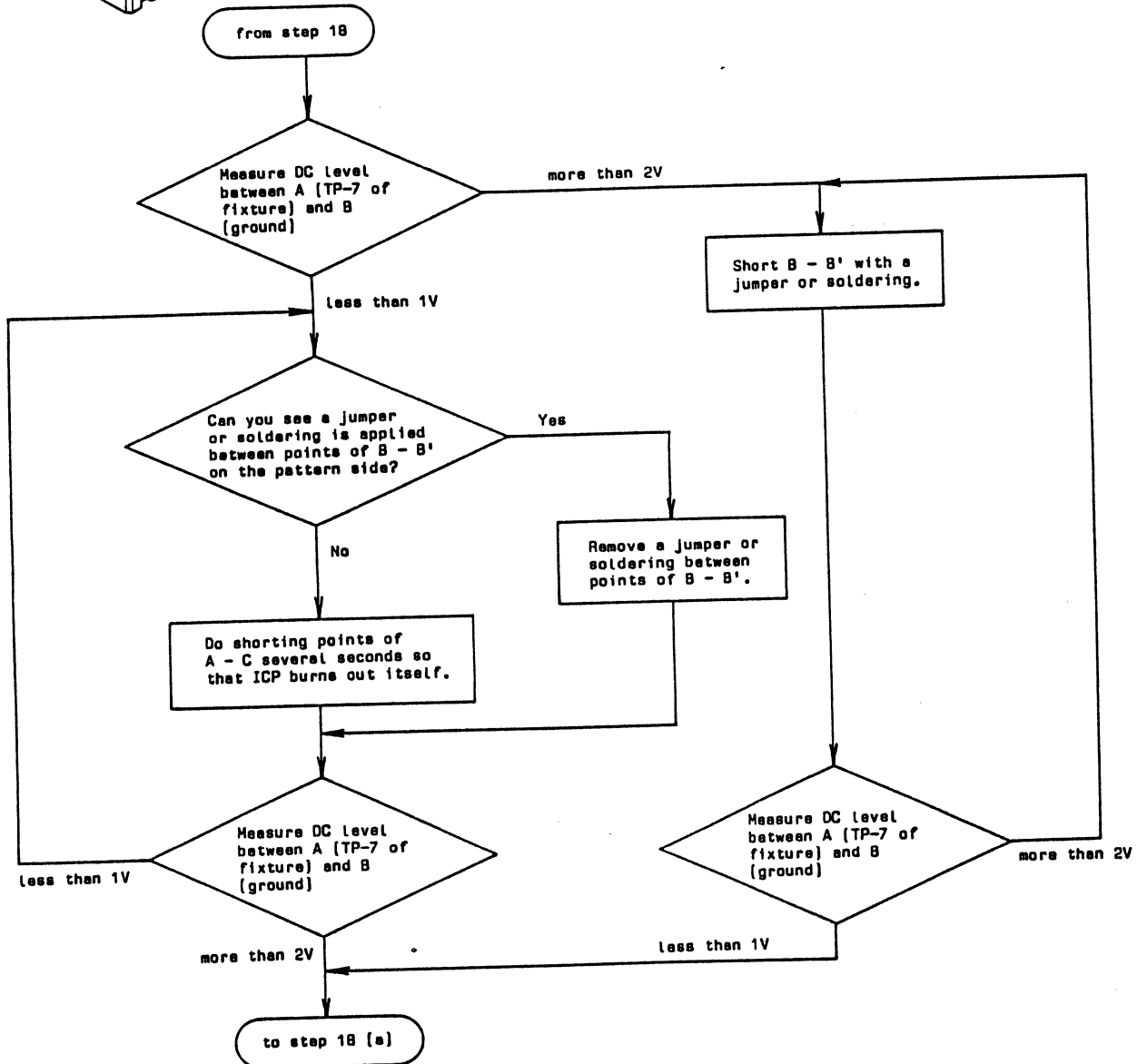
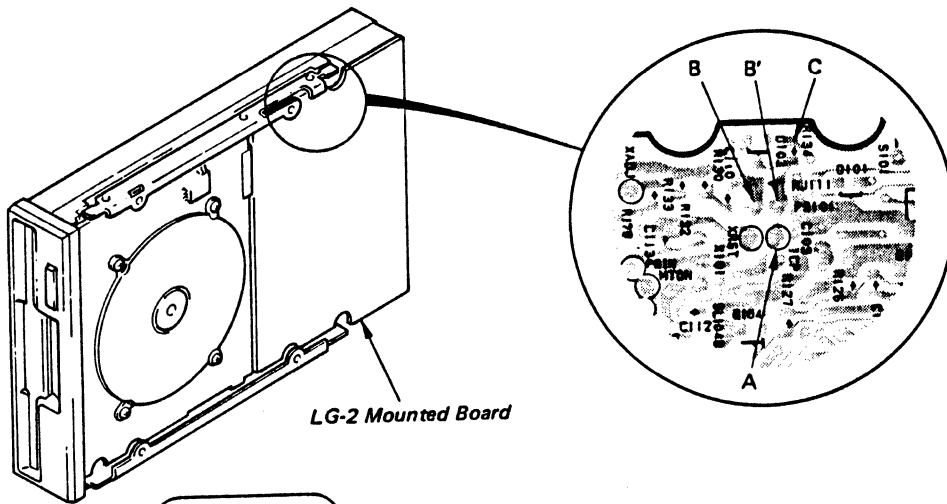

5-2 HEAD COMPLIANCE

Disassemble the following parts and then perform the measurement.

- a. Cover Ass'y (Refer to 4-1)

5-2-1 Tools and Measuring Equipment

- a. Oscilloscope
- b. Fixture-10
- c. MFD Function Checker II
- d. IF Board 52/53
- e. Pad Weight
- f. Level Disk (OR-D46WA)

5-2-2 Measurement

- a. Connect the drive to the MFD Function Checker II. (Refer to Fig. 2-14) Insert the level disk in place.
- b. Connect the CH-1 and CH-2 probes of oscilloscope to TP-2 of IF Board 52/53 and TP-3 of MFD Function Checker II. The oscilloscope is triggered by CH-2.
- c. Move the head until it arrives at TRK79, and then pad weight is loaded on head carriage ass'y as shown in Fig. 5-2.
- d. Write "2F" on TRK79.
- e. Observe the waveform of out-put signal by setting the timing knob of oscilloscope to 20msec.

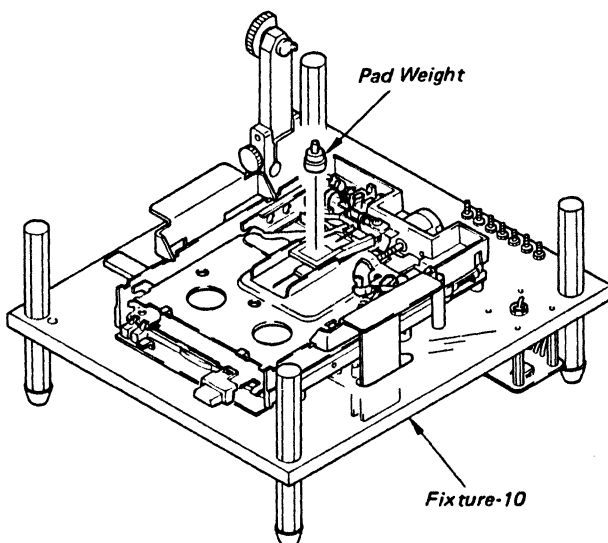

Fig. 5-2 Head Compliance Measurement

- f. Take the Pad Weight, and check if the out-put signal level variation at between unloading and loading of the Pad Weight is 5% or less of that obtained by item "e".

5-2-3 Adjustment

- a. If the out-put signal level does not meet item 5-2-2 "f", replace the head carriage ass'y. (Refer to 4-9)

5-3 INDEX PHASE

Disassemble the following parts and then perform the measurement and adjustment.

- a. Cover Ass'y (Refer to 4-1)

5-3-1 Tools and Measurement Equipment

- a. Oscilloscope
- b. MFD Function Checker II
- c. IF Board 52/53
- d. 50 Auto Disk (OR-D157WA)
- e. Fixture-10
- f. Index Adj. Lever
- g. ⊕ Driver 2mm / LR Driver

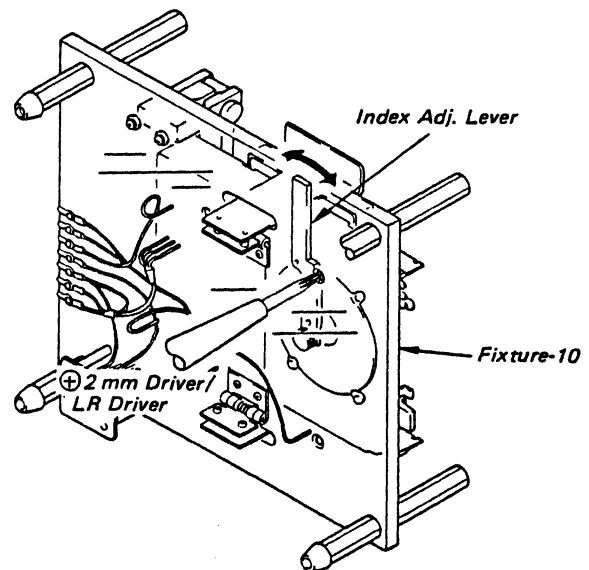

Fig. 5-3 (a) Index Phase Adjustment

5-3-2 Measurement

- a. Install the Index Adj. Lever onto Fixture-10. (Refer to 2-2-4)
- b. Connect the drive to the MFD Function Checker II. (Refer to Fig. 2-14)
- c. Insert the 50 Auto Disk in place.

- d. Connect the CH-1 and CH-2 probes of oscilloscope to TP-2 of IF Board 52/53 and TP-3 of MFD Function Checker II. The oscilloscope is triggered by CH-2.
- e. Move the head to TRK40.
- f. Check if the phase relation at both sides between the INDEX signal and output signal meets the specification (400 μsec) as shown in Fig. 5-3 (b).

5-3-3 Adjustment

- a. If the phase relation described above does not meet the specification, adjust Hall IC Ass'y so that output signals are located in zone L as shown in Fig. 5-3 (b) with an Index Adj. Lever.

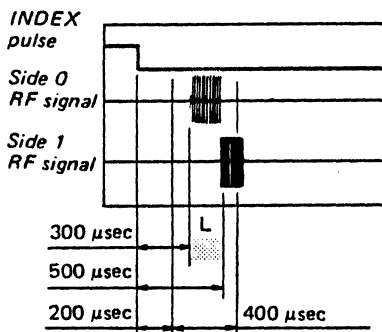

(b)

Fig. 5-3 Index Phase Adjustment

5-4 HEAD CLEANING

5-4-1 Tools and Measuring Equipment

- a. Cleaning Disk (OR-D29WA)
- b. MFD Function Checker II
- c. Fixture-10

5-4-2 Cleaning with Cleaning Disk

- a. Connect the drive to the MFD Function Checker II. (Refer to Fig. 2-14)
- b. Move the head until it arrives at an unused track of the cleaning disk.
- c. Set the cleaning disk in place and hold it for about 10 seconds. Thereafter, eject the cleaning disk.

Note: Do not use any scratched cleaning disk. Do not reuse any used track because reuse of the track weakens the cleaning effect on the head.

Note: Cross out numbers of the used tracks on a cleaning disk label, as shown in the example for avoiding reusage.

Cleaning Disk									
Check Column									
00	01	02	03	04	05	06	07	08	09
10	11	12	13	14	15	16	17	18	19
20	21	22	23	24	25	26	27	28	29
30	31	32	33	34	35	36	37	38	39
40	41	42	43	44	45	46	47	48	49
50	51	52	53	54	55	56	57	58	59
60	61	62	63	64	65	66	67	68	69
70	71	72	73	74	75	76	77	78	79

OR-D29WA

SECTION 6
PARTS LOCATION AND LIST
(Serial No. 9,500,001 thru 9,600,000)

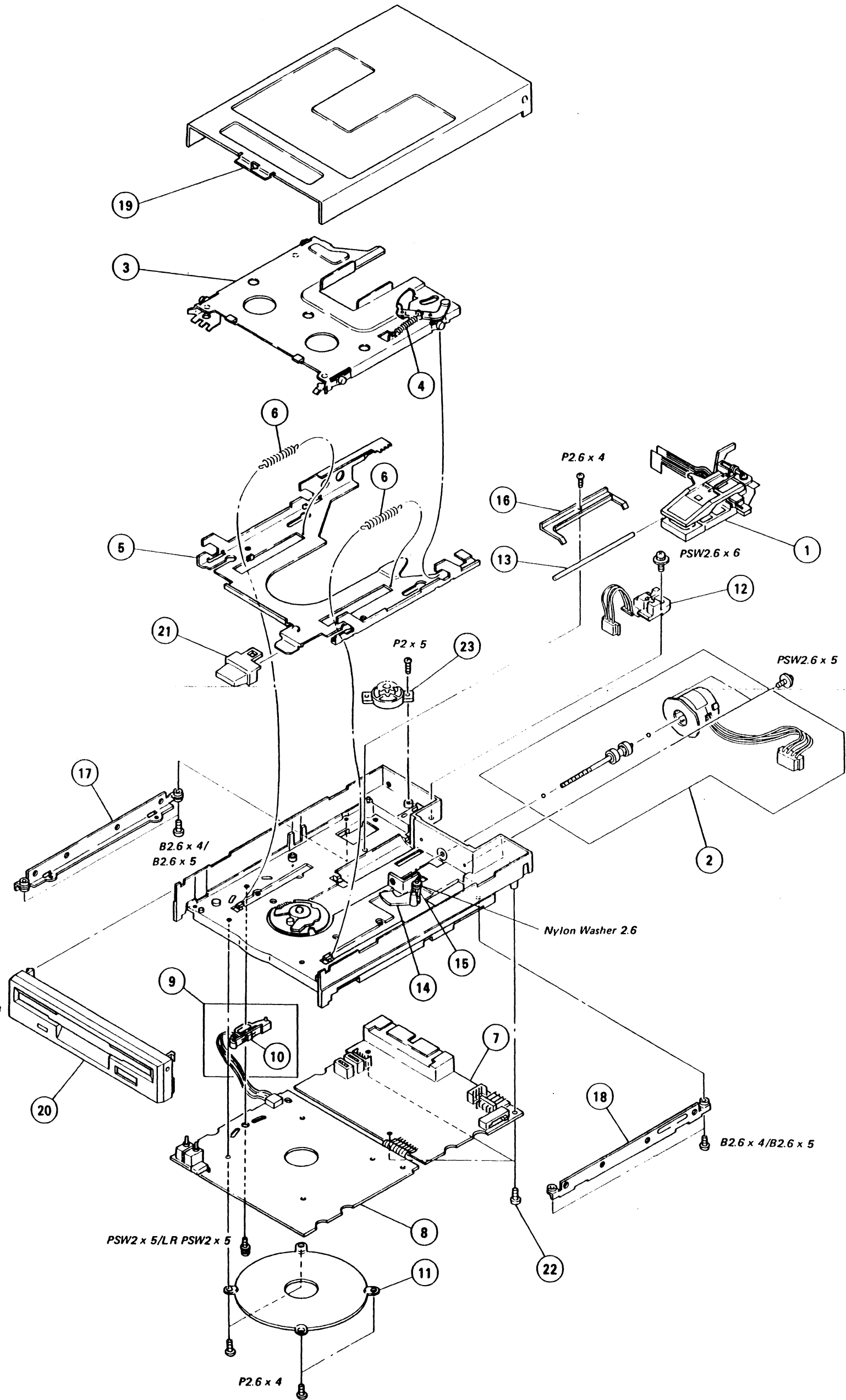

6-2. MECHANICAL PARTS LIST

- Note:** 1. Parts printed in **Bold-Face type** are normally stocked for replacement purposes. The remaining parts shown in this list are not normally required for routine service work. Orders for parts not shown in **Bold-Face type** will be processed, but allow for additional delivery time.
2. The screws and washers may be supplied with the substitution that is similar to ones listed because of part-standardization program in SONY.
3. Before part's ordering or replacement, refer to section 4-12 "Combination of Head Carriage Ass'y and LG-2 Mounted Board".

<u>No.</u>	<u>Parts No.</u>	<u>Description</u>
1	A-8010-248-A	Head Carriage Ass'y (P) (Refer to Note 3)
	A-8010-249-A	Head Carriage Ass'y (Q) (Refer to Note 3)
2	A-8010-253-A	Stepping Motor Ass'y
3	A-8010-233-A	Cassette Holder Ass'y
4	4-613-114-01	Tension Spring
5	A-8010-234-A	Slide Plate Ass'y
6	4-613-132-01	Tension Spring
7	A-8051-418-A	LG-2 (7L) Mounted Board (Refer to Note 3)
8	A-8051-366-A	MT-2 (7A) Mounted Board
9	A-8080-291-A	Hall IC Ass'y
10	8-759-404-25	DN6845S-D
11	X-4613-102-1	Stator Yoke Ass'y
12	1-808-058-11	00 Sensor
13	4-606-001-11	Slide Guide Shaft
14	4-613-103-01	Trigger Arm
15	4-613-104-01	Spring
16	4-613-105-01	Guide Retainer
17	X-4613-105-1	Bracket Ass'y (Left)
18	X-4613-106-1	Bracket Ass'y (Right)
19	X-4613-104-1	Cover Ass'y
20	A-8030-493-A	Front Panel Ass'y (Black)
21	4-613-121-01	Eject Button (Black)
22	3-701-428-01	Special Screw +B 2.6x4
23	3-712-786-01	Oil Damper
	7-621-255-35	Screw +P 2x5
	7-621-259-25	Screw +P 2.6x4
	7-621-775-20	Screw +B 2.6x5
	4-613-717-01	Screw LR PSW 2x5
	7-621-759-35	Screw +PSW 2.6x5
	7-621-759-45	Screw +PSW 2.6x6
	7-623-923-11	Nylone Washer 2.6

6-3. OVER ALL DIAGRAM

6-3-1. Interconnection Diagram

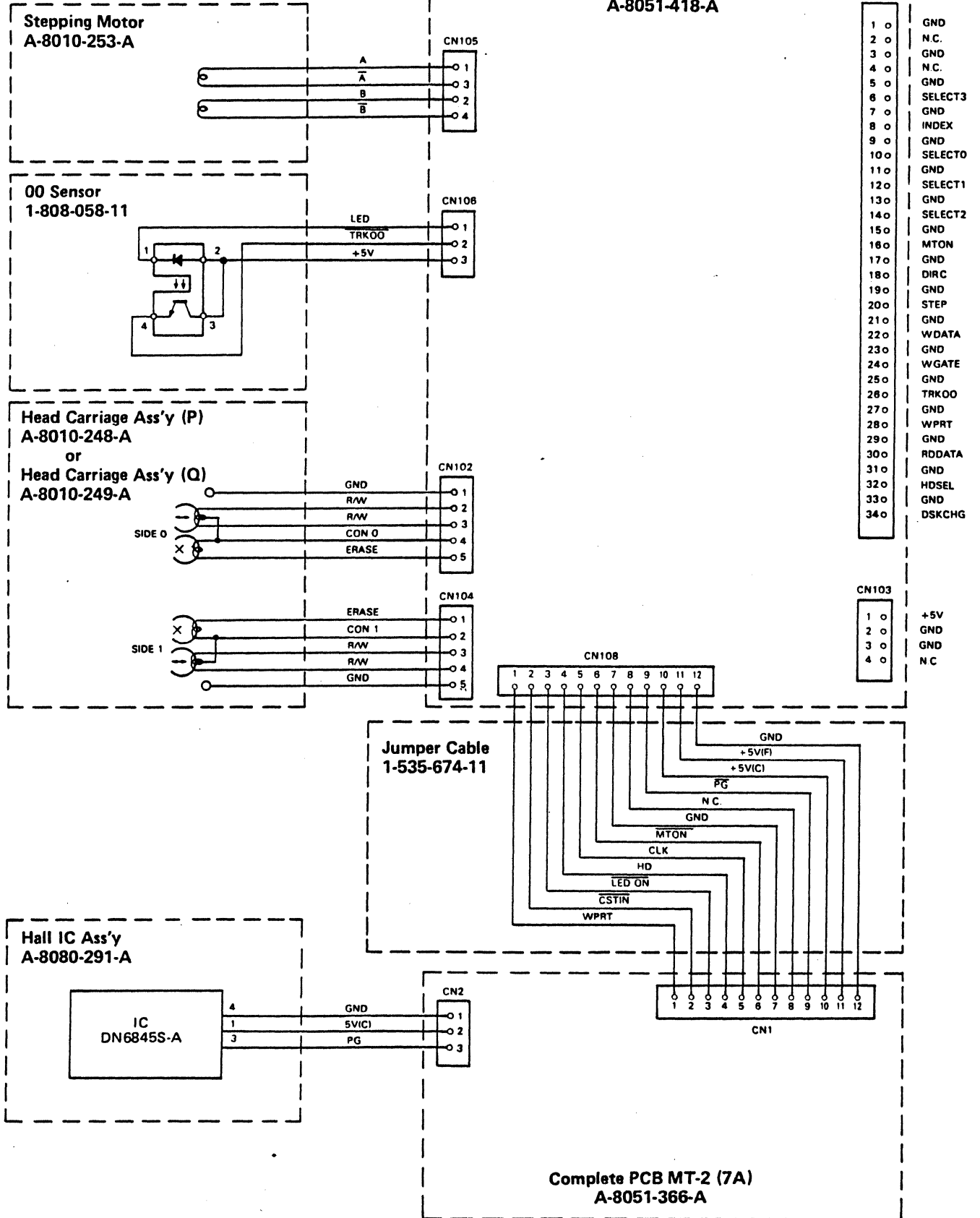

6-4. CIRCUIT DIAGRAM

6-4-1. Circuit Diagram on LG-2 (7L)

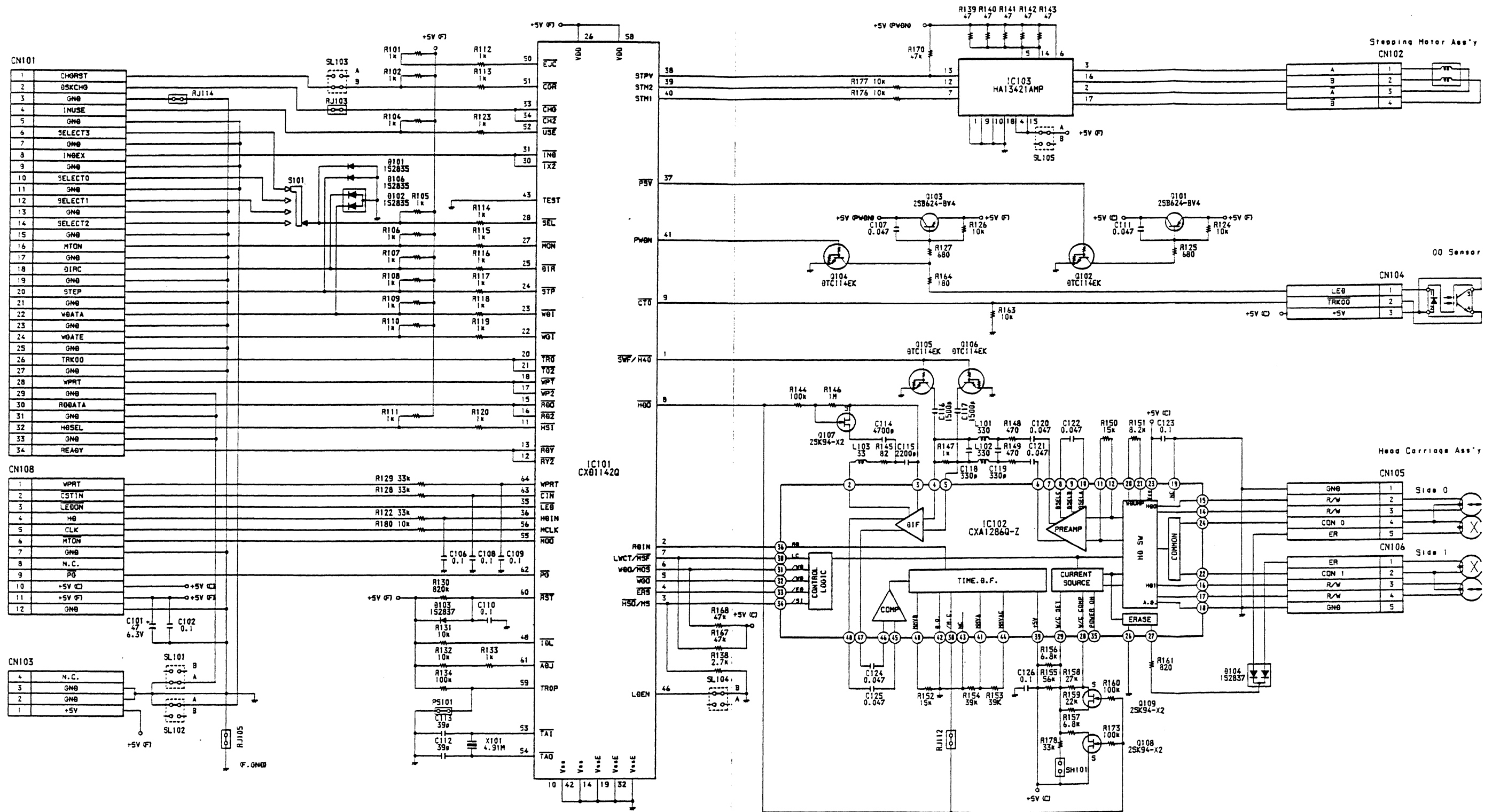

Circuit Diagram on MT-2 (7A)

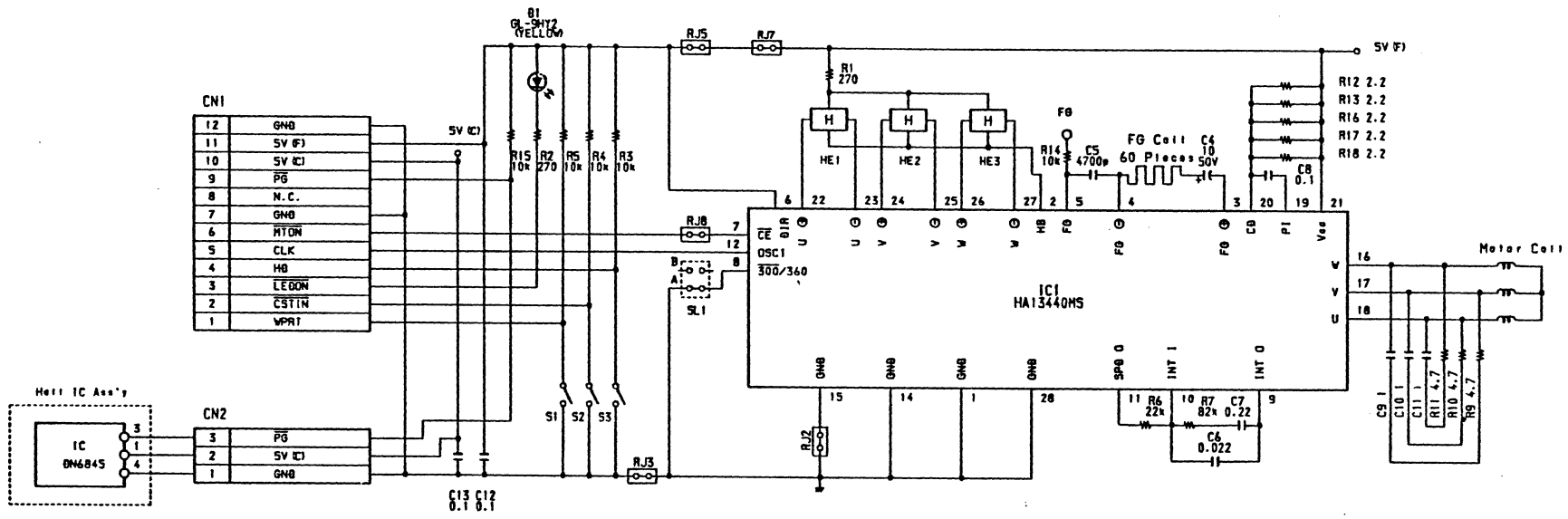

6-5. PARTS LAYOUT

6-5-1. Parts Layout on LG-2 (7L)

- Component Side -

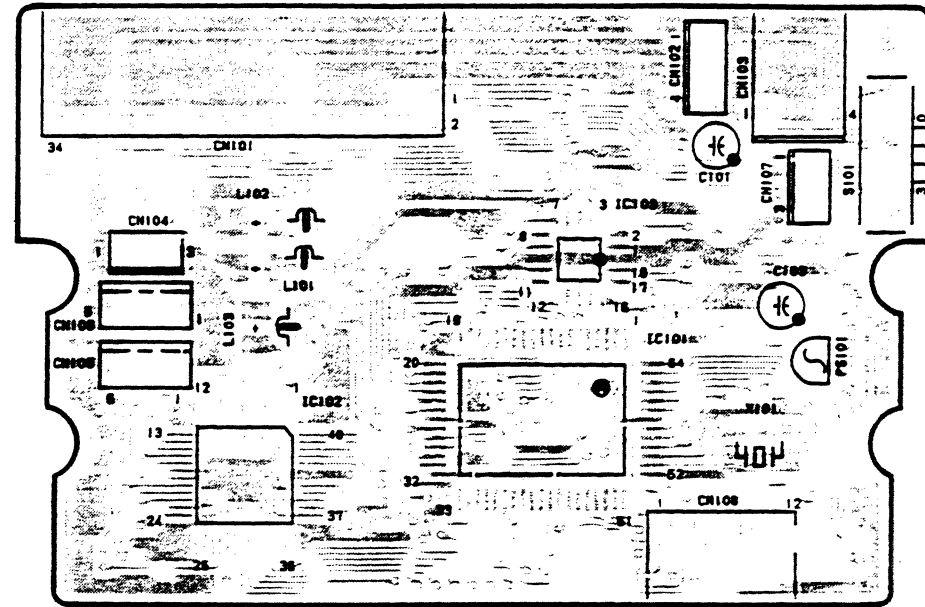

- Pattern Side -

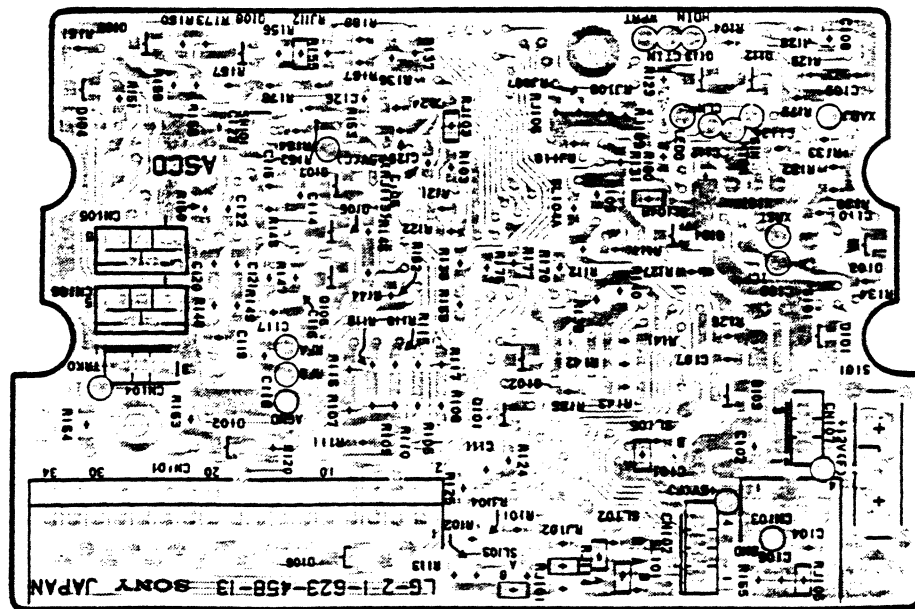

6-5-2. Parts Layout on MT-2 (7A)

- Component Side -

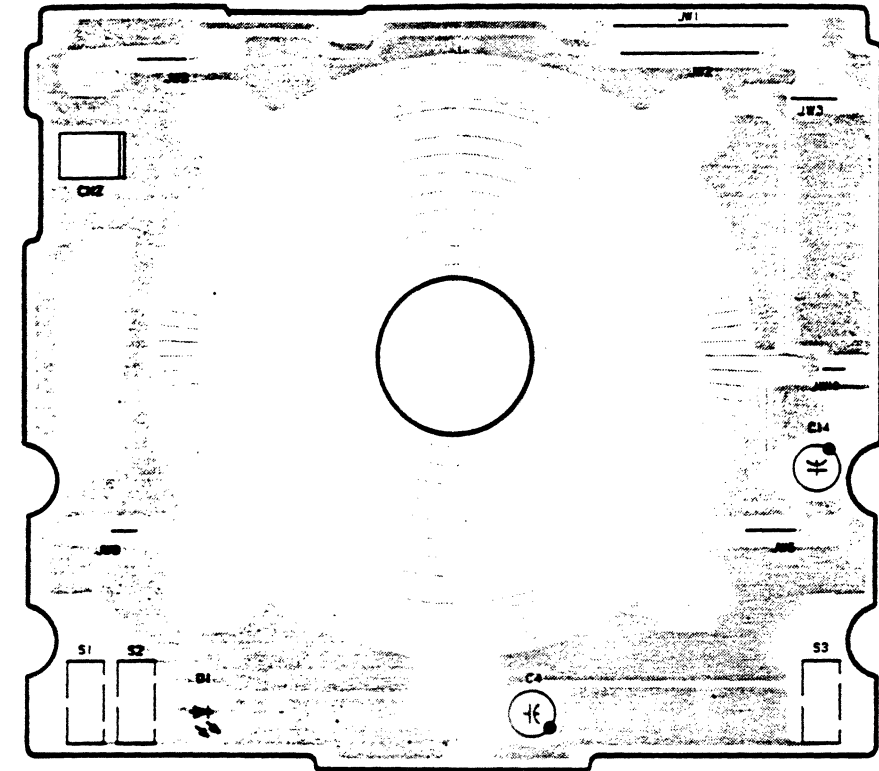

- Pattern Side -

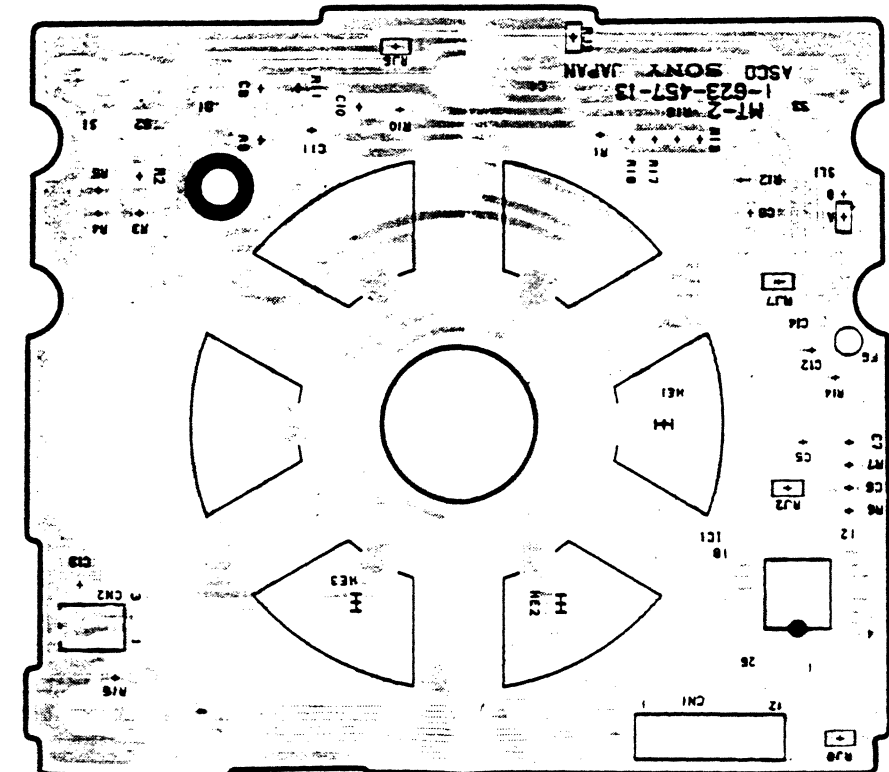

6-6-2 Chip parts replacement procedure

This unit uses chip components such as carbon resistor, ceramic capacitor, transistor and diode in some circuits. It also uses IC's of flat-pack type. As the appearance of carbon resistor and ceramic capacitor are identical, distinguishing of each can be possible by visual check of reference address of silk-screen print on the printed circuit board. As the shape of transistor and diode are same, they also are distinguished by the reference address of silk-screen print.

Tools:

Soldering iron: 20W

(If possible, use soldering tip with heat-controller of $270 \pm 10^\circ\text{C}$)

Desoldering metal braid ("SOLDER TAUL" or equivalent)

Solder (of 0.6mm dia. is recommended.)

Tweezers

Soldering Conditions:

Tip temperature; $270 \pm 10^\circ\text{C}$

Solder within 2sec. per an electrode

Higher temperature or longer tip application than specified may be damaged to the chip component.

(1) Resistor and capacitor

- Add heat onto the chip-part by the top of soldering iron tip and slide the chip-part aside when the solder is melted.
- Confirm visually with care that there is no pattern peeling, damage, and/or bridge where the part was removed or its surrounding.
- Presolder the pattern into thin where the part was removed.
- Place a new chip-part onto the pattern and solder both sides.

CAUTION: Do not use the chip-part again once used.

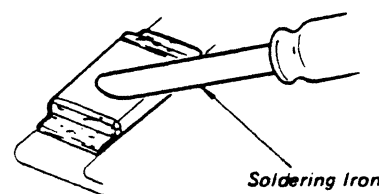

(2) Transistor and diode

- Cut the leads of the semiconductor part to be removed with a cutter.
- Remove the each pin of semiconductor from the pattern by tweezers while heating the pin by soldering iron.
- Confirm visually with care that there is no pattern peeling, damage, and/or bridge where the part was removed or its surrounding.
- Presolder the pattern into thin where the part was removed.
- Place a new semiconductor onto the pattern and solder the leads.

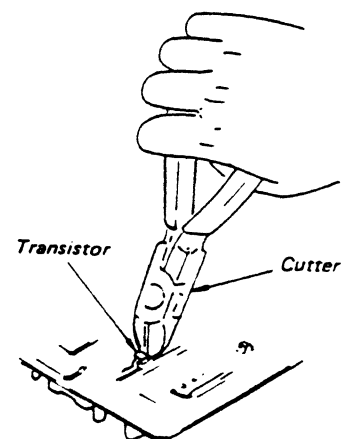

(3) IC (Flat-pack type)

- Cut the leads of the IC to be removed with a cutter.
- Remove the each pin of IC from the pattern by tweezers while heating the pin by soldering iron.
- Confirm visually with care that there is no pattern peeling, damage, and/or bridge where the part was removed or its surrounding.

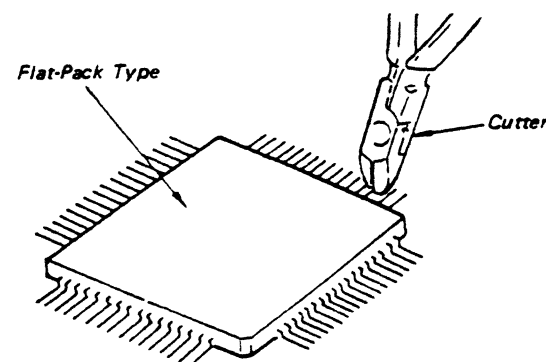

- Presolder the pattern into thin where the part was removed.
- Place a new IC onto the pattern and solder it.
- Confirm by a tester that each conduction between IC's terminal and copper pattern is surely made.
- If not, resolder the portion.

SECTION 7
PARTS LOCATION AND LIST
(Serial No. 1,000,001 - 2,000,000)

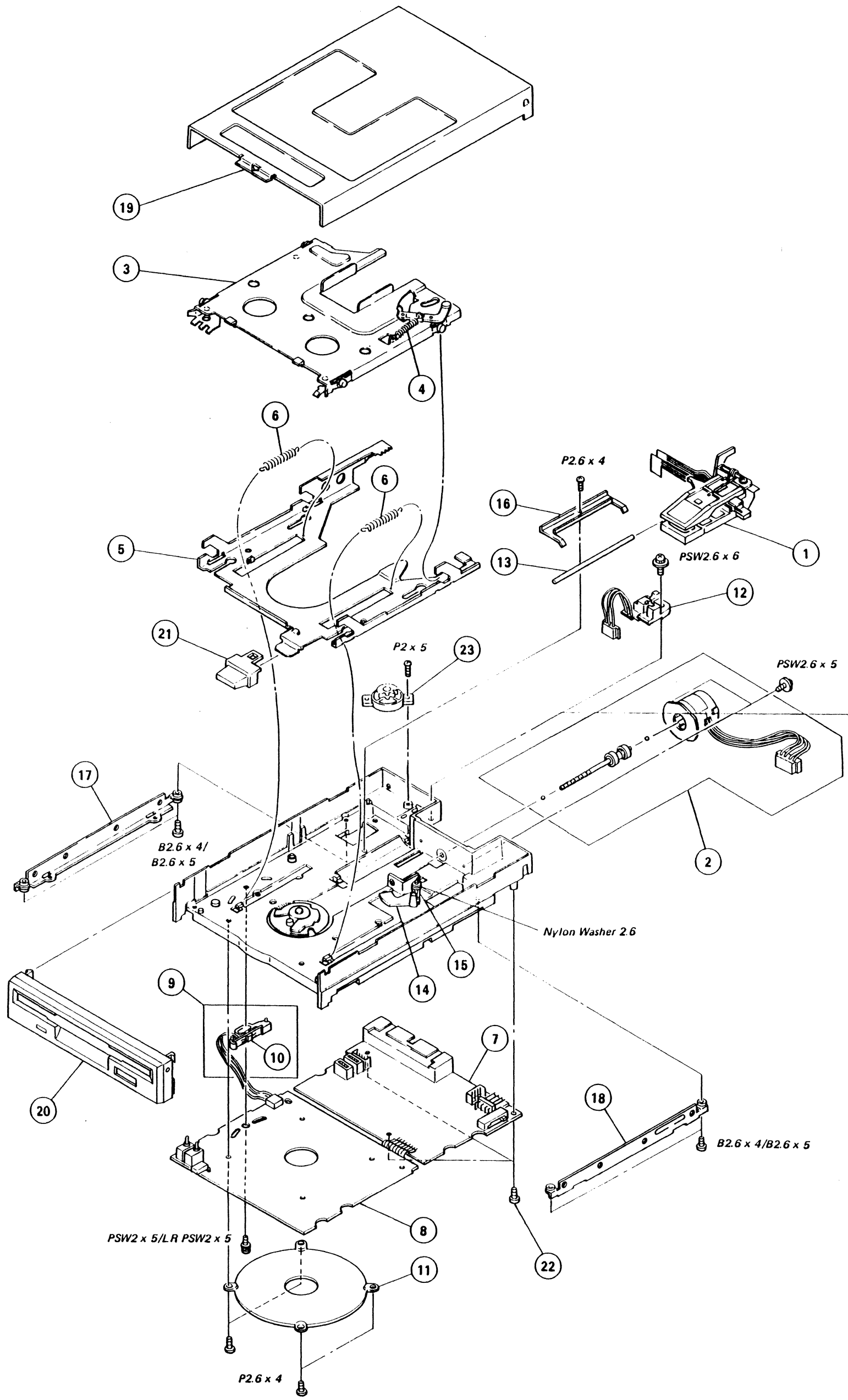

7-2. MECHANICAL PARTS LIST

- Note:** 1. Parts printed in **Bold-Face type** are normally stocked for replacement purposes. The remaining parts shown in this list are not normally required for routine service work. Orders for parts not shown in **Bold-Face type** will be processed, but allow for additional delivery time.
2. The screws and washers may be supplied with the substitution that is similar to ones listed because of part-standardization program in SONY.
3. Before part's ordering or replacement, refer to section 4-12 "Combination of Head Carriage Ass'y and LG-2 Mounted Board".

<u>No.</u>	<u>Parts No.</u>	<u>Description</u>
1	A-8010-248-A	Head Carriage Ass'y (P) (Refer to Note 3)
	A-8010-249-A	Head Carriage Ass'y (Q) (Refer to Note 3)
2	A-8010-253-A	Stepping Motor Ass'y
3	A-8010-233-A	Cassette Holder Ass'y
4	4-613-114-01	Tension Spring
5	A-8010-234-A	Slide Plate Ass'y
6	4-613-132-01	Tension Spring
7	A-8051-365-A	LG-2 (7D) Mounted Board (Refer to Note 3)
8	A-8051-366-A	MT-2 (7A) Mounted Board
9	A-8080-291-A	Hall IC Ass'y
10	8-759-404-25	DN6845S-D
11	X-4613-102-1	Stator Yoke Ass'y
12	1-808-058-11	00 Sensor
13	4-606-001-11	Slide Guide Shaft
14	4-613-103-01	Trigger Arm
15	4-613-104-01	Spring
16	4-613-105-01	Guide Retainer
17	4-613-122-01	Bracket (Left) (Serial No. 1,000,001 thru 1,017,866)
	X-4613-105-1	Bracket Ass'y (Left) (Serial No. 1,017,867 and higher)
18	4-613-123-01	Bracket (Right) (Serial No. 1,000,001 thru 1,017,866)
	X-4613-106-1	Bracket Ass'y (Right) (Serial No. 1,017,867 and higher)
19	X-4613-104-1	Cover Ass'y
20	A-8030-493-A	Front Panel Ass'y (Black)
21	4-613-121-01	Eject Button (Black)
22	3-701-428-01	Special Screw +B 2.6x4
23	3-712-786-01	Oil Damper
	7-621-255-35	Screw +P 2x5
	7-621-259-25	Screw +P 2.6x4
	7-621-775-10	Screw +B 2.6x4 (Serial No. 1,000,001 thru 1,017,866)
	7-621-775-20	Screw +B 2.6x5 (Serial No. 1,017,867 and higher)
	2-640-315-01	Screw +PSW 2x5 (Serial No. 1,000,001 thru 1,027,250)
	4-613-717-01	Screw LR PSW 2x5 (Serial No. 1,027,251 and higher)
	7-621-759-35	Screw +PSW 2.6x5
	7-621-759-45	Screw +PSW 2.6x6
	7-623-923-11	Nylone Washer 2.6

7-3. OVER ALL DIAGRAM

7-3-1. Interconnection Diagram

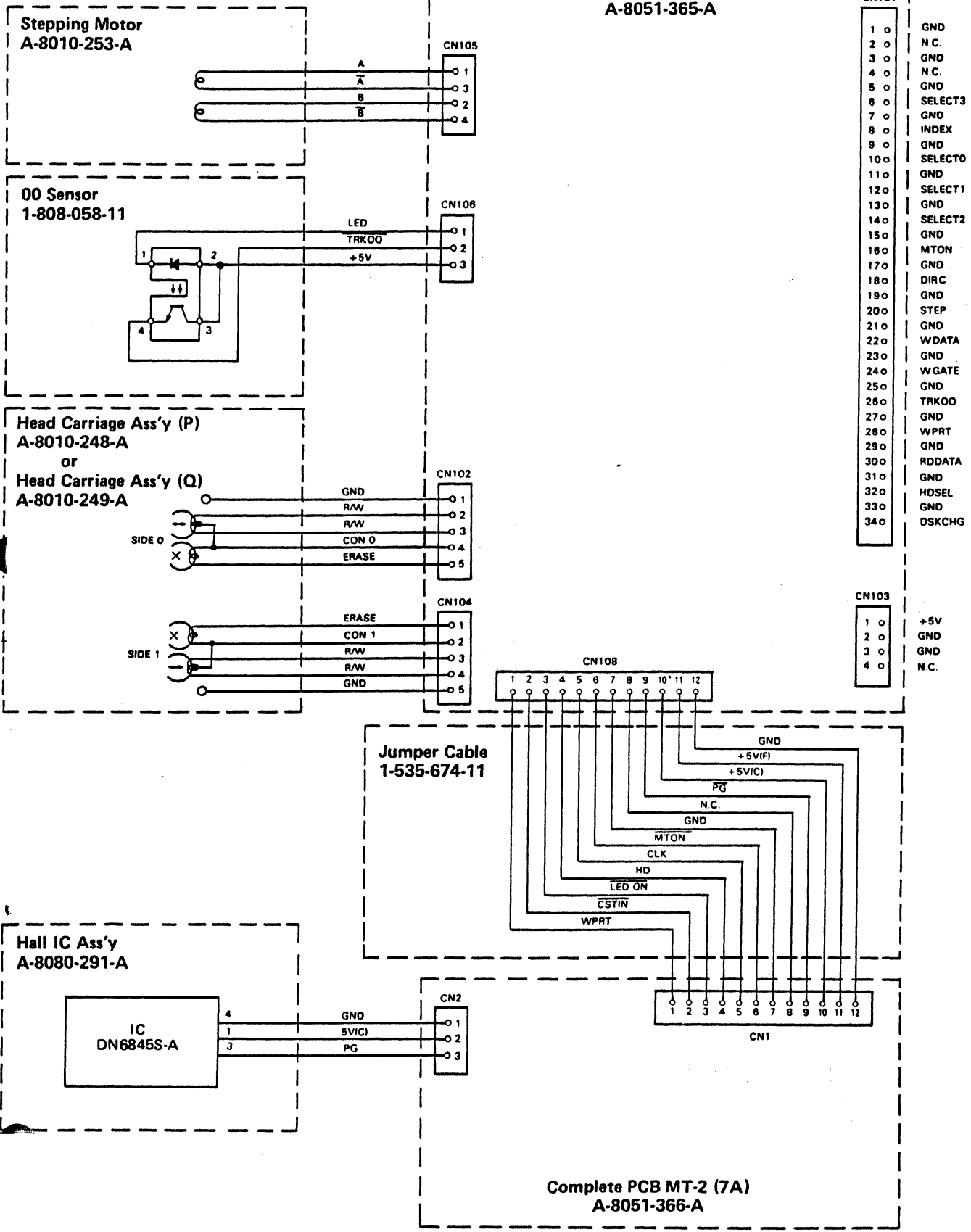

7-4. CIRCUIT DIAGRAM

7-4-1. Circuit Diagram on LG-2 (7D)

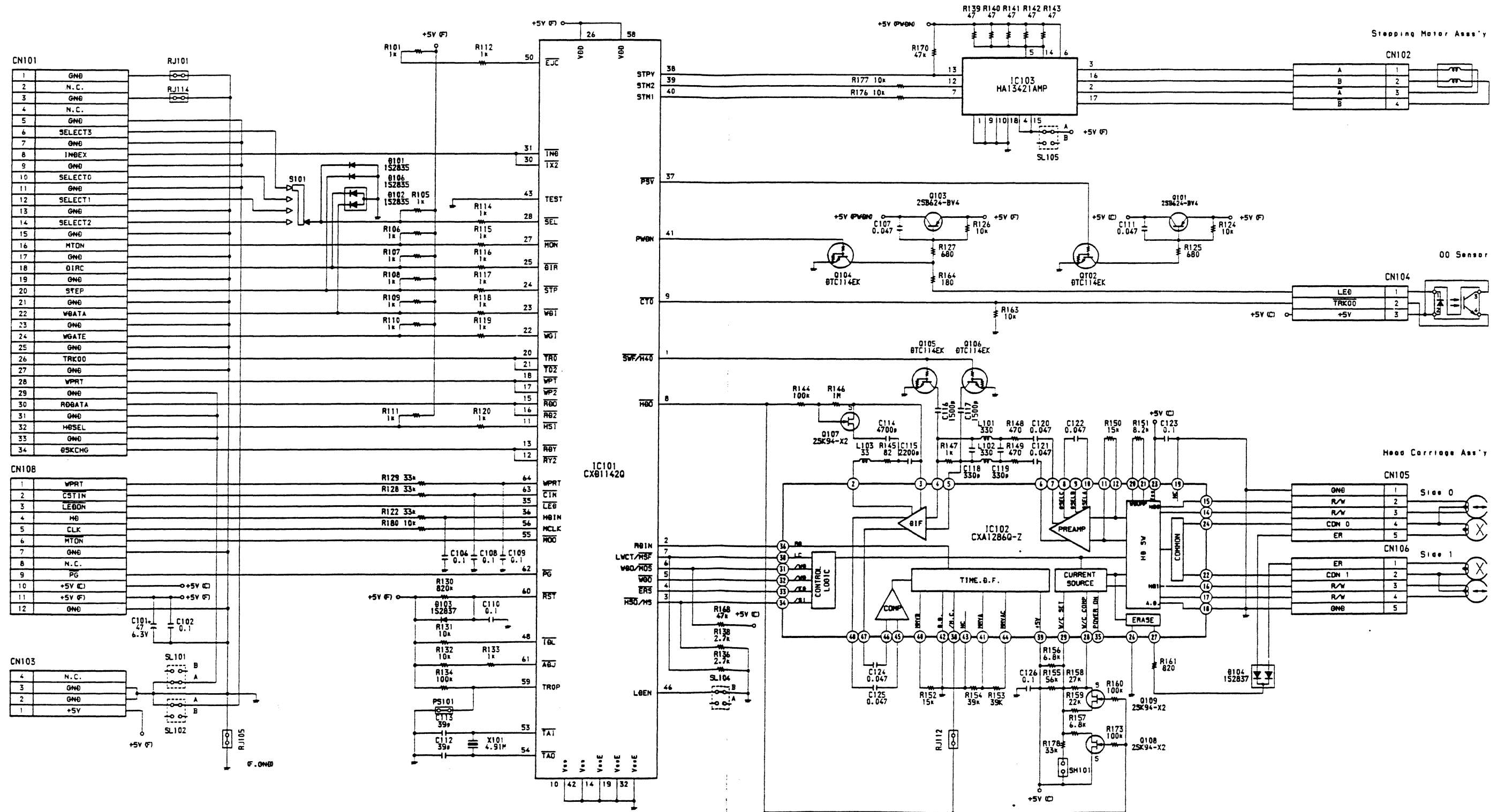

7-4-2. Circuit Diagram on MT-2 (7A)

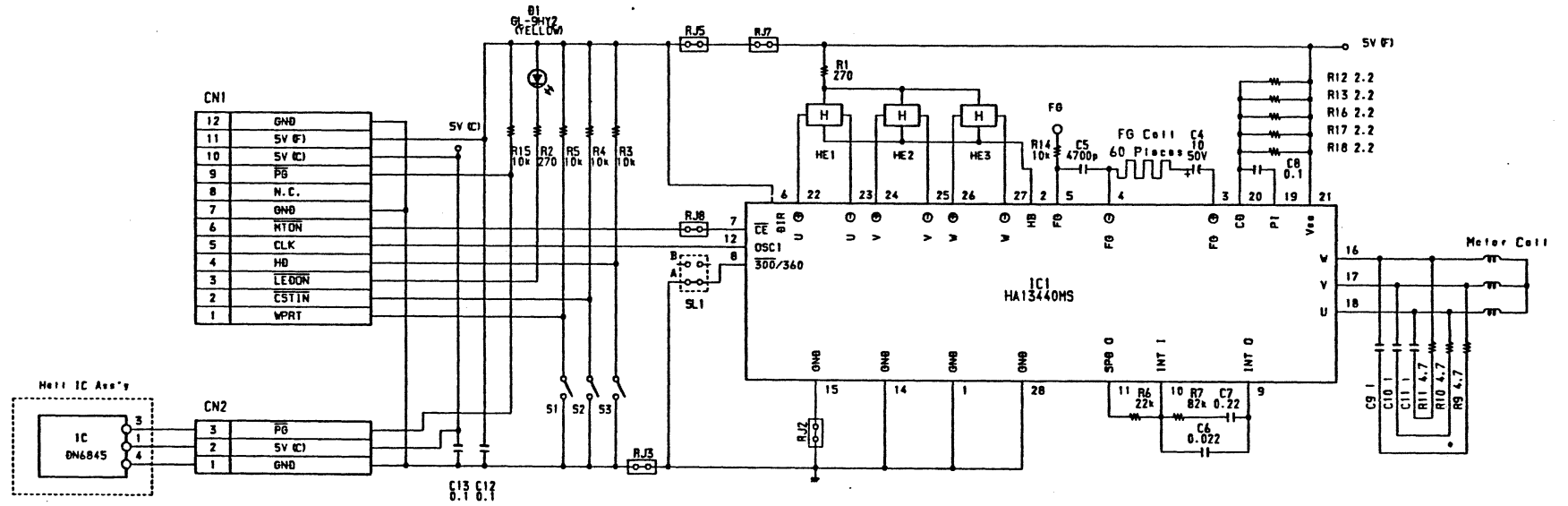

PARTS LAYOUT

7-5-1. Parts Layout on LG-2 (7D)

- Component Side -

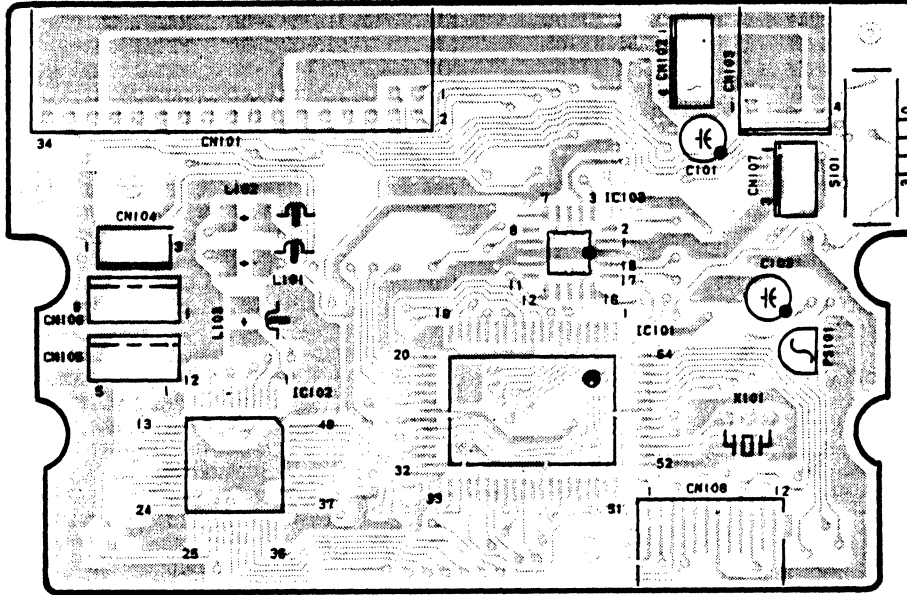

- Pattern Side -

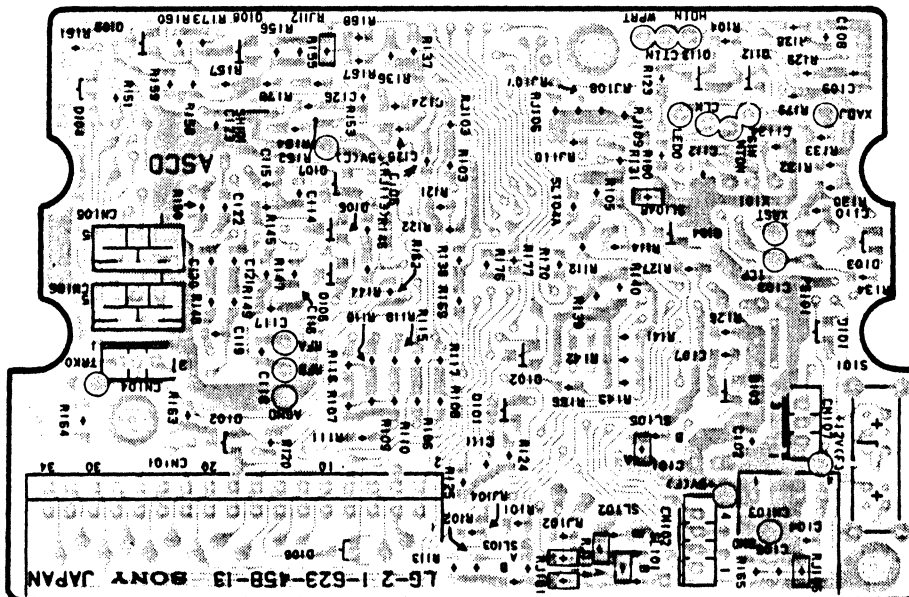

7-6-2 Chip parts replacement procedure

This unit uses chip components such as carbon resistor, ceramic capacitor, transistor and diode in some circuits. It also uses IC's of flat-pack type. As the appearance of carbon resistor and ceramic capacitor are identical, distinguishing of each can be possible by visual check of reference address of silk-screen print on the printed circuit board. As the shape of transistor and diode are same, they also are distinguished by the reference address of silk-screen print.

Tools:

Soldering iron: 20W

(If possible, use soldering tip with heat-controller of $270 \pm 10^\circ\text{C}$)

Desoldering metal braid ("SOLDER TAUL" or equivalent)

Solder (of 0.6mm dia. is recommended.)

Tweezers

Soldering Conditions:

Tip temperature; $270 \pm 10^\circ\text{C}$

Solder within 2sec. per an electrode

Higher temperature or longer tip application than specified may be damaged to the chip component.

(1) Resistor and capacitor

- Add heat onto the chip-part by the top of soldering iron tip and slide the chip-part aside when the solder is melted.
- Confirm visually with care that there is no pattern peeling, damage, and/or bridge where the part was removed or its surrounding.
- Presolder the pattern into thin where the part was removed.
- Place a new chip-part onto the pattern and solder both sides.

CAUTION: Do not use the chip-part again once used.

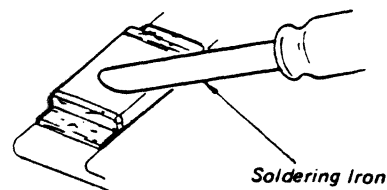

(2) Transistor and diode

- Cut the leads of the semiconductor part to be removed with a cutter.
- Remove the each pin of semiconductor from the pattern by tweezers while heating the pin by soldering iron.
- Confirm visually with care that there is no pattern peeling, damage, and/or bridge where the part was removed or its surrounding.
- Presolder the pattern into thin where the part was removed.
- Place a new semiconductor onto the pattern and solder the leads.

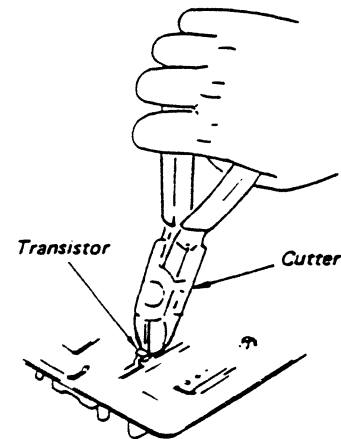

(3) IC (Flat-pack type)

- Cut the leads of the IC to be removed with a cutter.
- Remove the each pin of IC from the pattern by tweezers while heating the pin by soldering iron.
- Confirm visually with care that there is no pattern peeling, damage, and/or bridge where the part was removed or its surrounding.

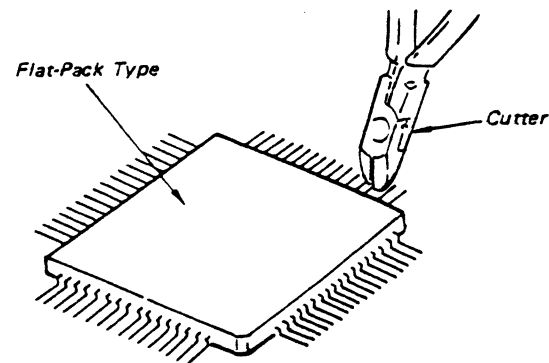

- Presolder the pattern into thin where the part was removed.
- Place a new IC onto the pattern and solder it.
- Confirm by a tester that each conduction between IC's terminal and copper pattern is surely made.
- If not, resolder the portion.

SECTION 8 TRANSISTORS / DIODES / ICS PIN ARRANGEMENT

GL-9HY2

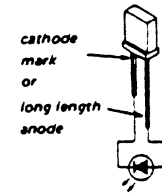

1S2835

-TOP VIEW-

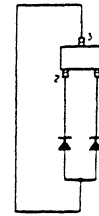

1S2837

-TOP VIEW-

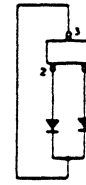

HA13421AMP

- TOP VIEW -

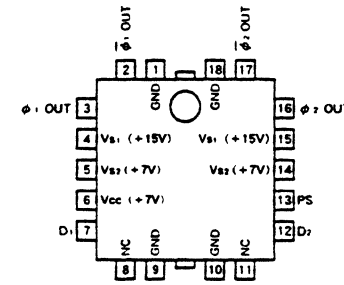

D1/D2 : Direction Input
PS : Power Save Input

INPUT		OUTPUT	
Direction	Power Save	ϕ	ϕ
0	0	0	Hs1
1	0	Hs1	0
0	1	0	Hs2
1	1	Hs2	0

Hs1 : Vs1 LEVEL
Hs2 : Vs2 LEVEL
0 : LOW LEVEL
1 : HIGH LEVEL

2SB624-BV4

-TOP VIEW-

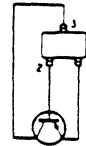

DTC114EK

-TOP VIEW-

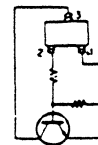

DN6845S-D

- TOP VIEW -

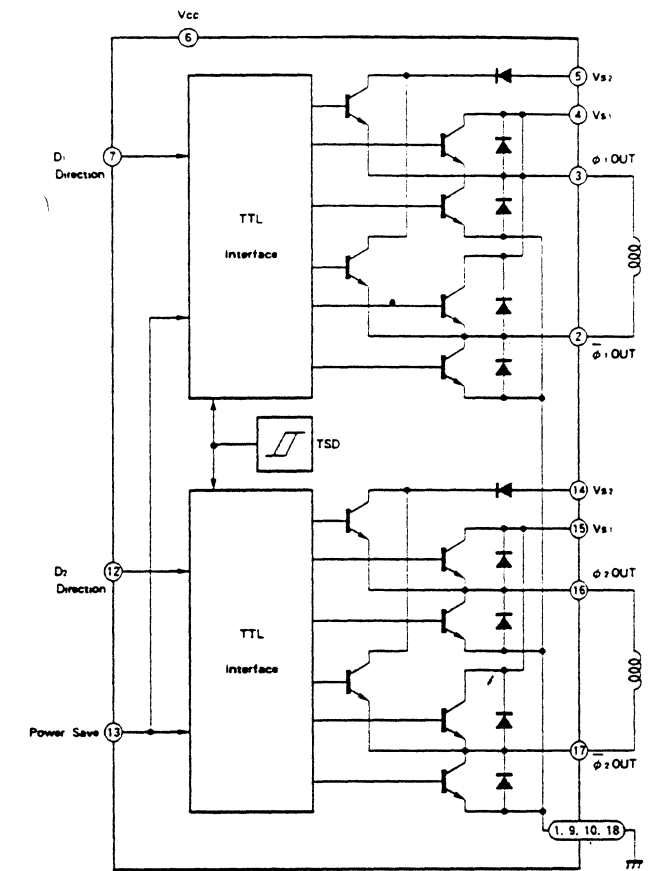
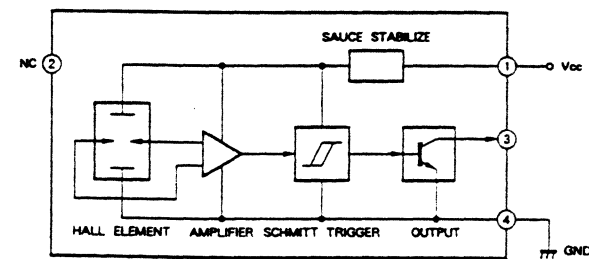
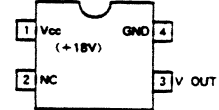

XD1142Q

TOP VIEW -

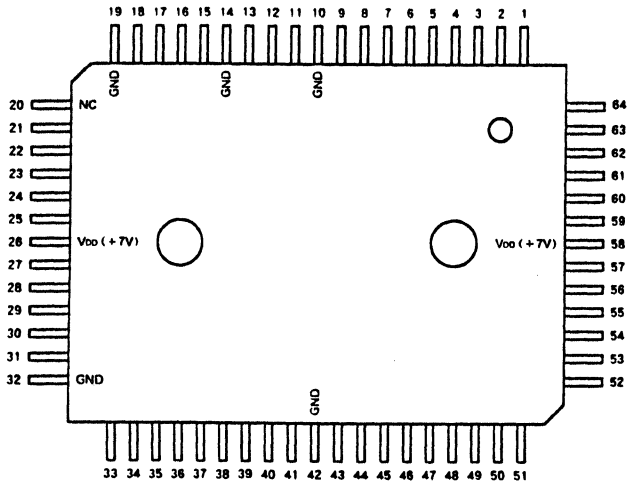

Pin	Symbol	I/O	Description
1	SWF / (H40)	O / (I)	Read filter select / (MCLK mode select)
2	RDIN	I	Read data
3	HS0	O	High density select
4	ERS	O	Erase gate
5	WG0	O	Write gate
6	WDO / (MOS)	O / (I)	Write data / (control mode select)
7	LWCT / (MSF)	O / (I)	Write current select / (control mode select)
8	HS0 / (MS)	O / (I)	Head select control / (control mode select)
9	CT0	I	Track 00 sense
11	HS1	I	Head select
12	RYZ / (CH2)	O	Ready (Three state) / (Disk change (Three state))
13	RDY / (CHG)	O	Ready (open drain) / (Disk change (Open drain))
15	RDO	O	Read data (open drain)
16	ROZ	O	Read data (Three state)
17	WPZ	O	Write protect (Three state)
18	WPT	O	Write protect (open drain)
20	TR0	O	Track 00 (open drain)
21	T0Z	O	Track 00 (three state)
22	WGI	I	Write gate
23	WDI	I	Write data
24	STP	I	Step signal
25	DIR	I	Direction select
27	MON	I	Spindle motor control
28	SEL	I	Drive select
29	M2	I	Erase gate control
30	IXZ	O	Index (three state)
31	IND	O	Index (open drain)
33	CHG	O	Disk change (open drain)
34	CHZ	O	Disk change (three state)
35	LED	O	In-use LED control (open drain)
36	HDIN	I	High density disk mode select
37	PSV	O	Power save mode select
38	STPV	O	Stepper power select
39	STM2	O	Stepper control 2
40	STM1	O	Stepper control 1
41	PWDN	O	Stepper power save select

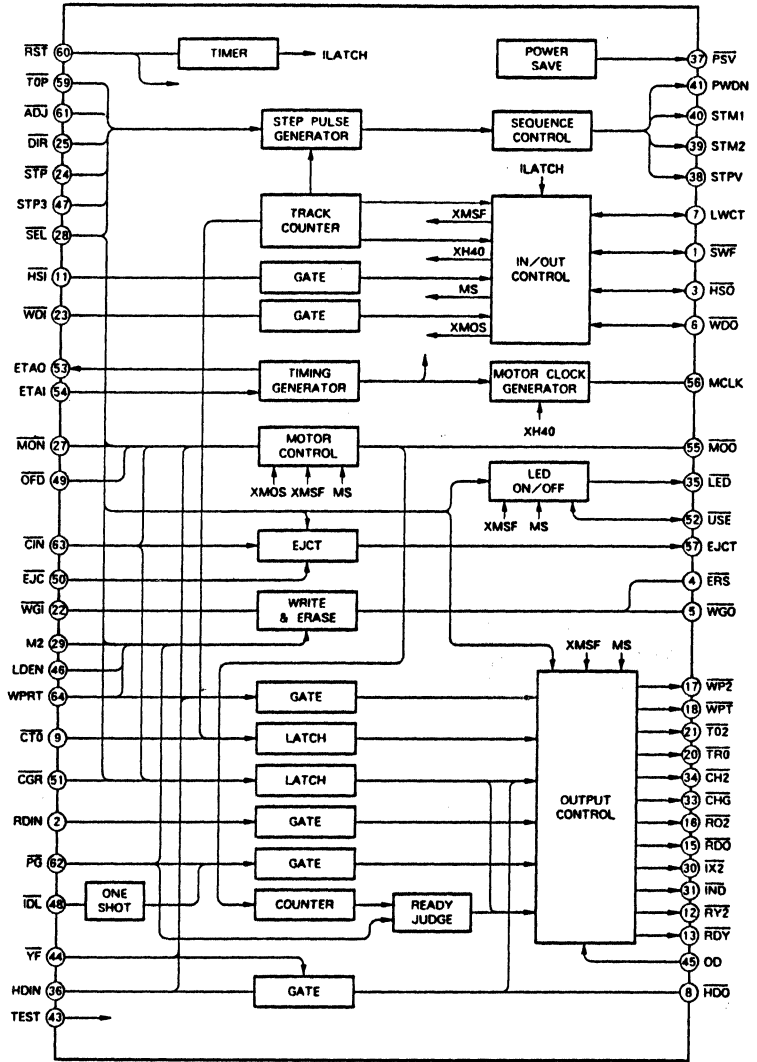

Pin	Symbol	I/O	Description
43	TEST	I	Test mode select
44	YF	I	Control mode select
45	OD	I	System I/F output level select
46	LDEN	I	Erase gate control
47	STP3	I	Step rate select
48	IDL	I/O	Index delay I/O
49	OFD	I	Spindle motor stop mode select
50	EJC	I	Disk eject control
51	CGR	I	Disk change reset
52	USE	I	In-use LED control
53	TA0	O	Clock generator
54	TA1	I	Clock generator
55	MOO	O	Spindle motor control
56	MCLK	O	Devided clock
57	EJCT	O	Disk eject
59	TROP	I	Stepper phase select
60	RST	I	Controller reset
61	ADJ	I	Stepping mode select
62	PG	I	Index sense
63	CIN	I	Cassette-in sense
64	WPRT	I	Write protect sense

HA13440MS

- TOP VIEW -

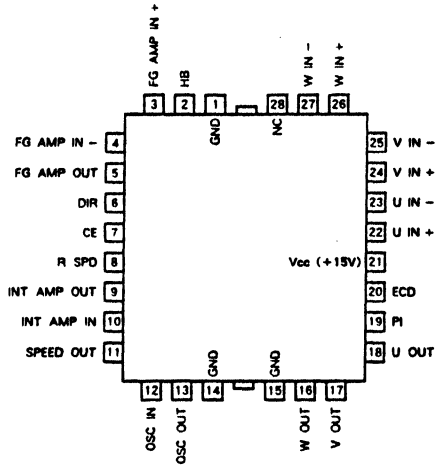

CE	DIR	INPUTS						OUTPUTS		
		U+	U-	V+	V-	W+	W-	U	V	W
0	0	1	0	0	1	1	0	1	0	Open
		1	0	0	1	0	1	1	Open	0
		1	0	1	0	0	1	Open	1	0
		0	1	1	0	0	1	0	1	Open
		0	1	1	0	1	0	0	Open	1
		0	1	0	1	1	0	Open	0	1
	1	1	0	0	1	1	0	0	1	Open
		1	0	0	1	0	1	0	Open	1
		1	0	1	0	0	1	Open	0	1
		0	1	1	0	0	1	1	0	Open
		0	1	1	0	1	0	1	0	Open
		0	1	0	1	1	0	Open	1	0
1	X	X	X	X	X	X	X	Open	Open	

0 : LOW LEVEL
 1 : HIGH LEVEL
 X : Don't Care

- HB : Hall Bias
- FG AMP IN + : FG Amplifier Input +
- FG AMP IN - : FG Amplifier Input -
- FG AMP OUT : FG Amplifier Output
- DIR : Direction
- CE : Chip Enable
- R SPD : Rotation Speed
- INT AMP OUT : Integrator Amplifier Output
- INT AMP IN : Integrator Amplifier Input
- SPEED OUT : Speed Discriminator Output
- OSC IN : OSC Input
- OSC OUT : OSC Output
- W OUT : W Phase Output
- V OUT : V Phase Output
- U OUT : U Phase Output
- PI : Phase Indemifity
- ECD : Electric Current Detection
- U IN + : U Phase Input +
- U IN - : U Phase Input -
- V IN + : V Phase Input +
- V IN - : V Phase Input -
- W IN + : W Phase Input +
- W IN - : W Phase Input -

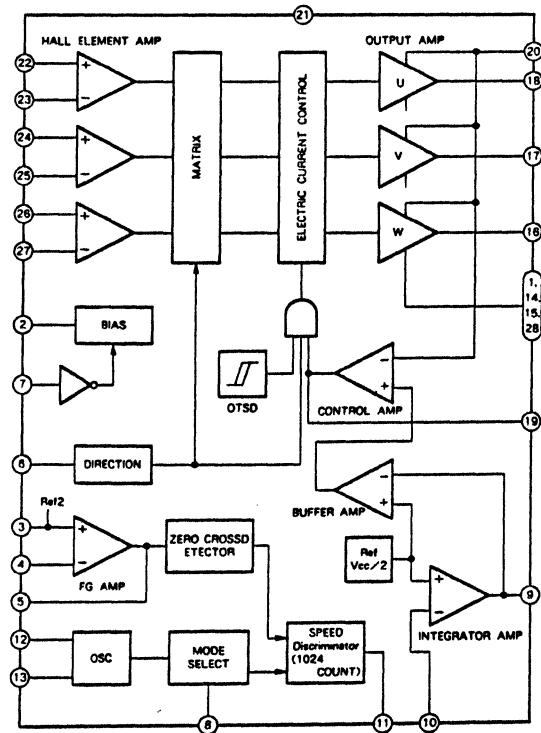

CXA1186Q-Z

- TOP VIEW -

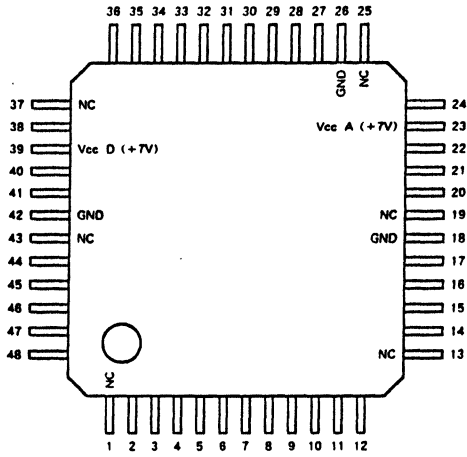

- DIFF CONSTANT A : Connect external components to set the differential constant.
- DIFF CONSTANT B : Connect external components to set the differential constant.
- DIFF IN A : Differentiator input.
- DIFF IN B : Differentiator input.
- PRE OUT A : Pre-Amplifier output.
- PRE OUT B : Pre-Amplifier output.
- GAIN SEL A. B. C. : The voltage gain of Pre-Amplifier can be set to 100 or 200 by connecting a capacitor between these pins.
- READ DUMP A : Connect the head dumping resistor for Read.
- READ DUMP B : Connect the head dumping resistor for Read.
- HEAD 0 A : Input and output terminals for Read/Write head on Side 0.
- HEAD 0 B : Input and output terminals for Read/Write head on Side 0.
- HEAD 1 A : Input and output terminals for Read/Write head on Side 1.
- HEAD 1 B : Input and output terminals for Read/Write head on Side 1.
- WRITE DUMP A : Connect the head dumping resistor for Write.
- WRITE DUMP B : Connect the head dumping resistor for Write.
- COMMON 1 : Connect the center tap of Read/Write head on Side 1.
- COMMON 0 : Connect the center tap of Read/Write head on Side 0.
- ERASE OUT : Open Collector Erase current output.
- W/C COMP : Connect a resistor for Write current compensation.
- W/C SET : Connect a resistor to determine Write current.
- WRITE CURRENT : Digital input pin. When WRITE CURRENT is set to "L", Write current in increased.
- WRITE DATA : Digital input pin with Schmitt-Triggered function. When WRITE DATA is set from "H" to "L", Write current is switched.
- WRITE GATE : Digital input pin. When WRITE GATE is set to "L", Write circuit block becomes Active, causing Write current to be ON.
- ERASE GATE : Digital input pin. When ERASE GATE is set to "L", Erase circuit becomes Active, causing Erase current to be ON.
- SIDE 1 : Digital input pin. When SIDE 1 is set to "L", Read/Write head on Side 1 becomes Active.
- POWER ON : Open Collector output. When Power Monitor circuit detects the power supply voltage drop, POWER ON output is ON.
- READ DATA : Read Data output.
- MMVA CONTROL : Digital input pin. When MMVA CONTROL is set to "L", the pulse width of Time Domain Filter's mono-multi is decreased.
- MMVB : Connect a resistor to determine the pulse width of Read Data output.
- MMVA : Connect a resistor to determine the pulse width of Time Domain Filter's mono-multi.
- MMVA COMP : Connect a resistor for the pulse width compensation of Time Domain Filter's mono-multi.
- COMP IN A : Comparator input.
- COMP IN B : Comparator input.
- DIFF OUT A : Differentiator output.
- DIFF OUT B : Differentiator output.

