

Molecular Computer™

Multiprocessor Computer Systems

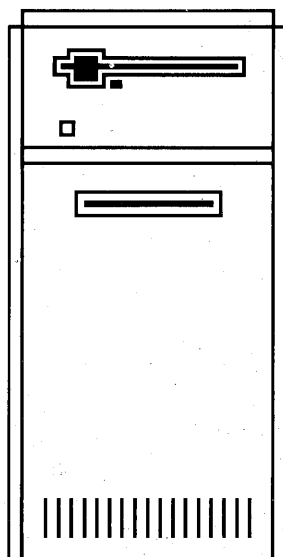

Supermicro Series



PREFACE

This manual describes how to use the Supermicro computer. It provides enough information for you to perform tasks such as program development, program execution, and file maintenance. The manual is written for you if you are already familiar with computer software fundamentals and the CP/M Operating System. If you have no experience with CP/M, read *CP/M Operating System Manual* in conjunction with this manual.

The next section, Chapter Summary, briefly describes the chapters in this manual and suggests a reading path to help you use the manual efficiently.

Chapter Summary

Chapter 1, Introduction to the Supermicro, gives an overview of the Supermicro series. It lists and describes the components of the Supermicro, the Supermicro series, and the upgrade kits.

Chapter 2, Installation, provides information on site preparation, unpacking, system setup, and attaching terminals and peripherals.

Chapter 3, Supermicro Operation, describes the procedures for operating the Supermicro hardware. This chapter tells how to turn on the power, turn off the power, insert diskettes, and make copies of diskettes.

Chapter 4, Diagnostic Utilities, describes the Supermicro utilities that are run while the Supermicro is in single-user (or diagnostic) mode. The procedures described in this chapter include: formatting and verifying the hard disk and diskettes, configuring the hard disk, and loading n/STAR onto the hard disk.

Chapter 5, Tape Backup, describes the operation of the tape backup unit and the tape backup utilities.

Chapter 6, n/STAR Operating System, includes a tutorial on the n/STAR security system and a detailed description of the n/STAR commands. This chapter also includes a description of printer operation and how to set up the security system for the first time.

Chapter 7, n/STAR Programmer's Guide, includes programming information for those users who wish to implement custom software under the n/STAR Operating System.

Documentation Conventions

A description of the symbolic conventions used throughout this manual follows. Familiarize yourself with these conventions before you continue reading.

Conventions used in this manual:

1. This manual uses the word RETURN to represent a carriage return, CTRL to represent the control key, and BREAK to represent any key or combination of key strokes that will reset the processor.

You may produce unique characters by typing a combination of keys simultaneously. For example, while holding down the CTRL key, type O to produce the CTRL-O characters. Key combinations such as these are hyphenated in this manual.



-
2. Terminal and console terminal are general terms used throughout all Supermicro documentation to represent any terminal device.
 3. In discussions of command syntax, upper-case letters represent command names which you must type. Lower-case italics represent a variable for which you must supply an entry.

Curved brackets { } enclose options. You may include the item in brackets, or omit it as you choose. This is a typical illustration of command syntax:

HOLD unit{/port}

This example shows that you must type the word **HOLD** followed by an entry that specifies the unit. Without leaving a space you may follow the unit entry with a slash [/] and an entry that identifies the port. Here is a typical command string:

HOLD 210/A

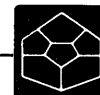

TABLE OF CONTENTS

1	Introduction to the Supermicro	1-1
1.1	Introduction	1-1
1.2	Supermicro Configuration	1-1
1.2.1	File Processor	1-2
1.2.2	Application Processors	1-2
1.2.3	m/BUS Architecture	1-3
1.2.4	Disk Drives	1-4
1.2.5	Supermicro Distribution Diskettes	1-4
1.2.6	Tape Backup Unit	1-5
1.2.7	AP/86 Performance Accelerator	1-6
1.3	Software for the Supermicro	1-6
1.3.1	n/STAR Operating System	1-6
1.3.2	Diagnostic Utilities	1-7
1.4	Supermicro Models	1-7
1.4.1	Supermicro 8	1-7
1.4.2	Supermicro 32	1-8
1.4.3	Supermicro 32X	1-8
1.4.4	Supermicro 64X	1-8
1.5	Supermicro Application Processors	1-8
1.5.1	Standard Supermicro Series Application Processors	1-9
1.5.2	Supermicro X Series Application Processors	1-9
1.6	Supermicro Options	1-9
1.6.1	Supermicro 8 Options	1-9
1.6.2	Supermicro 32 Options	1-10
1.6.3	Supermicro 32X Options	1-10
1.6.4	Supermicro 64X Options	1-10
1.7	Adding Terminals and Printers to the Supermicro	1-11
2	Installation	2-1
2.1	Site Preparation	2-1
2.1.1	Space Requirements	2-1
2.1.2	Power Requirements	2-2
2.1.3	Environmental Requirements	2-3
2.1.4	Cabling Considerations	2-3
2.2	Unpacking	2-3
2.3	System Setup	2-4
2.3.1	Initial Preparation	2-4
2.3.2	Terminal and Printer Connections	2-8
	Terminal Connections	2-9
	Printer Connections	2-10
2.3.3	Final Preparation	2-11
2.4	Creating Bootable System Diskettes	2-11
2.5	System Checkout	2-13



3	Supermicro Operation	3-1
3.1	Disk Utilization	3-1
3.2	Inserting Diskettes	3-1
3.3	Going Into Multi-User Mode	3-2
3.4	Going Into Diagnostic Mode	3-4
3.5	Turning Off the Power	3-5
3.5.1	Power Off in Multi-User Mode	3-5
3.5.2	Power Off in Diagnostic Mode	3-5A
3.6	The Importance of Backup	3-5A
3.6.1	Make Copies of System Diskettes	3-6
3.6.2	Backup Your Data	3-6
3.7	Making Copies of Diskettes	3-7
3.7.1	Copying Diskettes in Multi-User Mode	3-7
3.7.2	Copying Diskettes in Diagnostic Mode	3-8
3.8	Reset Procedures	3-12
3.8.1	Resetting the Application Processor	3-13
3.8.2	Resetting the File Processor	3-14
3.8.3	Resetting the System	3-14
4	Diagnostic Utilities	4-1
4.1	System Drives Under Diagnostic Mode	4-1
4.2	Formatting and Verifying Diskettes	4-1
4.3	Formatting, Verifying, and Configuring the Hard Disk	4-4
4.3.1	Formatting the Hard Disk	4-5
	Supermicro 32 and Supermicro 64	4-5
	Supermicro 8	4-7
4.3.2	Verifying the Hard Disk	4-8
	Supermicro 32 and Supermicro 64	4-8
	Supermicro 8	4-9
4.3.3	Configuring the Disk Table	4-10
4.4	Upgrading an Old Release of n/STAR	4-12
4.4.1	Upgrading from a 56K Version of n/STAR	4-12
4.4.2	Upgrading from a Non-56K Version of n/STAR	4-14
4.5	Loading n/STAR onto the Hard Disk	4-15
4.5.1	Installing the n/STAR Operating System Only	4-16
4.5.2	Installing n/STAR and the n/STAR Utilities	4-17
4.5.3	Installing n/STAR on an Empty Hard Disk	4-20
4.5.4	Installing CP/M Utilities onto the Hard Disk	4-21
5	Tape Backup	5-1
5.1	Purpose of Tape Backup	5-1
5.2	Operation of Tape Backup Unit	5-1
5.2.1	Handling Tape Cartridges	5-1
5.2.2	Inserting a Tape Cartridge	5-2



5.3	Tape Backup Tutorial	5-3
5.4	Tape Backup Program	5-3
5.4.1	Backing Up Disk Files to Tape	5-4
5.4.2	Restoring Disk Files from Tape	5-6
5.4.3	Listing Tape Directory	5-8
5.4.4	Retensioning the Tape	5-9
5.5	Tape Error Codes	5-10
6	n/STAR Operating System	6-1
	Introduction	6-1
6.1	n/STAR Disk Organization	6-1
6.2	n/STAR Security System Tutorial	6-1
6.2.1	Dividing Logical Drives into Volumes	6-3
6.2.2	Defining Volumes	6-4
6.2.3	Assigning Volumes to a User ID	6-4
6.2.4	Assigning Volume Passwords to User Profiles	6-6
6.2.5	Secured and Unsecured Volumes	6-6
6.2.6	Directory Search Default	6-7
6.2.7	System Event Logging	6-8
6.3	n/STAR Security System Commands	6-10
6.3.1	LOGON	6-10
6.3.2	LOGOFF	6-11
6.3.3	ASSIGN	6-11
6.3.4	MAINT	6-13
	Change the System Password	6-14
	User Maintenance	6-15
	Volume Maintenance	6-16
	Event Log Configuration	6-18
	Get Event Log File	6-19
	Print User and Volume Directories	6-19
	System Configuration	6-20
6.4	Other n/STAR Commands	6-23
6.4.1	D (Directory Utility)	6-23
6.4.2	DEVICES	6-23
6.4.3	DOWN	6-24
6.4.4	QMAINT	6-24
6.4.5	RESET	6-26
6.4.6	SET	6-27
6.4.7	SETBAUD	6-27
6.4.8	SUBMIT	6-28
6.4.9	TLINK	6-28
6.4.10	TOD	6-28D
6.4.11	WHO	6-28D
6.5	Diskette Access Under n/STAR	6-28E



6.6 Printer Operation	6-28F
6.6.1 Local Printer	6-28F
6.6.2 System Printer	6-29
6.6.3 Despooling Printer	6-29
6.7 Operation without the Security System	6-31
6.8 File and Record Locking	6-31
6.8.1 Automatic File Locking	6-31
6.8.2 CP/M File Sharing	6-32
6.8.3 Enhanced File Sharing	6-33
6.9 Using the Security System for the First Time	6-33
6.9.1 Volumes Already on the Hard Disk	6-33
6.9.2 Getting to Know the Security System	6-33
6.9.3 Step One - Create a Volume called USERSYS	6-34
6.9.4 Step Two - Define the Volumes	6-34
6.9.5 Step Three - Assign Volumes to User IDs	6-34
6.10 Security System Recovery	6-35
6.10.1 When One Terminal is Locked out of n/STAR	6-35
6.10.2 When All Terminals are Locked out of n/STAR	6-35
7 n/STAR Programmer's Guide	7-1
7.1 n/STAR System Interface	7-1
7.1.1 Memory Layout	7-1
7.1.2 BDOS Functions	7-3
Device Control Block Format	7-7B
Rules for Matching DCBs	7-7C
DCB Error Codes	7-7D
7.1.3 Interrupt Vectors	7-7H
7.1.4 Boot Sequence	7-8
7.1.5 Disk Buffer Pooling	7-9
7.2 File and Record Locking	7-10
7.2.1 Automatic File Locking	7-10
7.2.2 CP/M File Sharing	7-10
7.2.3 Enhanced File Sharing	7-10
7.3 Driver Interface Guide	7-11
7.3.1 Disk Drivers	7-11
7.3.2 Bus Driver	7-13
7.4 Hardware I/O Port Assignments	7-15
Appendices	
A Specifications	A-1
B Files on the Distribution Diskettes	B-1
C Volume Identification Chart	C-1
D n/STAR Error Messages	D-1
E Printer Interface Cables	E-1

Index

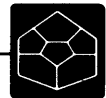

TABLES

2 INSTALLATION

Table 2-1	Terminal Interfacer Cable Wiring	2-9
Table 2-2	Printer Port Signal Lines Supported by n/STAR	2-10

4 DIAGNOSTIC MODE

Table 4-1	Logical Drives on the Supermicro — Diagnostic Mode	4-2
Table 4-2	Directory and Blocksize Table	4-11

6 N/STAR OPERATING SYSTEM

Table 6-1	Logical Drives on the Supermicro — Multi-User Mode	6-2
-----------	--	-----

7 PROGRAMMER'S GUIDE

Table 7-1	Physical Error Codes	7-4A
Table 7-2	Fixed Interrupt Vectors for the File Processor	7-8
Table 7-3	Fixed Interrupt Vectors for Application Processors	7-8
Table 7-4	Request Block Format for Disk Drives and Diskette Drivers	7-11
Table 7-5	Disk Error Summary — Supermicro 32 and Supermicro 64	7-12
Table 7-6	Disk Error Summary — Supermicro 8	7-13
Table 7-7	Address Format for Register H-L	7-14
Table 7-8	File Processor Port Assignments	7-16
Table 7-9	Application Processor Port Assignments	7-16

FIGURES

1 INTRODUCTION TO THE SUPERMICRO

Figure 1-1	The Supermicro	1-1
Figure 1-2	File Processor	1-2
Figure 1-3	Application Processors	1-2
Figure 1-4	m/BUS Interprocessor Link	1-3
Figure 1-5	Disk Drives	1-3
Figure 1-6	Supermicro Distribution Diskette	1-4
Figure 1-7	Tape Backup Unit in the Supermicro 8 and in the Supermicro 32	1-5
Figure 1-8	Tape Backup Unit in the Supermicro 64	1-5
Figure 1-9	n/STAR operating System Organization	1-6



2 INSTALLATION

Figure 2-1	Supermicro Computer Space Requirements	2-2
Figure 2-2	Location of Major Parts on Supermicro 8/Supermicro 32	2-5
Figure 2-3	Location of Major Parts on Supermicro 64	2-5
Figure 2-4	AC Voltage Connections on Power Distribution Panel	2-6
Figure 2-5	Location of Hard-disk Drive Lock on Supermicro 32	2-6
Figure 2-6	Location of Hard-disk Drive Locks on Supermicro 64	2-7
Figure 2-7	Location of External-device Connectors at the Rear of the Supermicro Computer	2-8

3 SUPERMICRO OPERATION

Figure 3-1	Disk Drives	3-1
Figure 3-2	Diskette Features	3-1
Figure 3-3	Inserting a Diskette	3-2
Figure 3-4	Closing the Diskette Drive	3-2
Figure 3-5	Turning on the Power	3-3
Figure 3-6	Inserting the Distribution Diskette	3-4
Figure 3-7	Tape and Diskette Backup	3-6

5 TAPE BACKUP

Figure 5-1	Inserting the Tape Cartridge into the Tape Drive	5-2
Figure 5-2	The Write-Project Switch	5-2
Figure 5-3	Example of a Tape Directory Listing	5-9

6 N/STAR OPERATING SYSTEM

Figure 6-1	Example of Volume Parameters on the Supermicro 8	6-3
Figure 6-2	Example of a Logical Drive Directory	6-3
Figure 6-3	Volume Profile Screen	6-4
Figure 6-4	Sample Volume Assignments in a User Profile	6-5
Figure 6-5	Schematic Example of Volume Assignments	6-5
Figure 6-6	Sample Event Log	6-8
Figure 6-7	Logged-Off Terminal Screen	6-10
Figure 6-8	User Profile Screen	6-12
Figure 6-9	Maintenance Menu	6-14
Figure 6-10	Current User Screen	6-15
Figure 6-11	User Profile Screen	6-15
Figure 6-12	Current Volume Screen	6-16
Figure 6-13	Volume Profile Screen	6-17
Figure 6-14	Event Log Parameters	6-18
Figure 6-15	Sample Volume Assignments Directory	6-20
Figure 6-16	System Configuration Screen	6-21
Figure 6-17	Queue Activity Report	6-24
Figure 6-18	Queue Status Screen	6-25
Figure 6-19	TLINK Main Menu	6-28A
Figure 6-20	TLINK Main Menu, AP/86 Device Acquired	6-28B
Figure 6-21	Returning to TLINK, AP/86 Device Acquired	6-28D



INTRODUCTION TO THE SUPERMICRO

1

1.1 INTRODUCTION

The Supermicro computer system provides multi-user operation allowing each user to run application programs under n/STAR Operating System. The Supermicro's n/STAR Operating System allows many users operating independently to share files and peripherals. n/STAR includes a sophisticated file management system and password security for files and system maintenance.

This user guide contains operating and programming information for the Supermicro. If you need information on maintenance and repairs, refer to the Supermicro Maintenance Manual. The Supermicro Maintenance Manual can be obtained from your authorized Molecular Computer Distributor.

The Supermicro User Guide and the programs it describes are copyrighted by Molecular Computer. All rights are reserved, and no license to copy or duplicate is granted with their distribution or sale.

Every effort has been made to make this manual clear and accurate. If you have any suggestions on how it can be improved, please fill in the Reader Response Card at the back of the manual, and return it to us.

1.2 SUPERMICRO CONFIGURATION

Based on the Z80 family of microprocessors, the Supermicro is composed of two types of single-board computers: the File Processor (FP) and one or more Application Processors (AP). With each terminal you add to the system, you also add an Application Processor. Each AP includes a Z80 CPU and 64K-bytes of memory dedicated to that terminal. The Z80-based File Processor controls interprocessor communications and the system resources, such as the hard disk and diskette drives, and the shared peripherals.

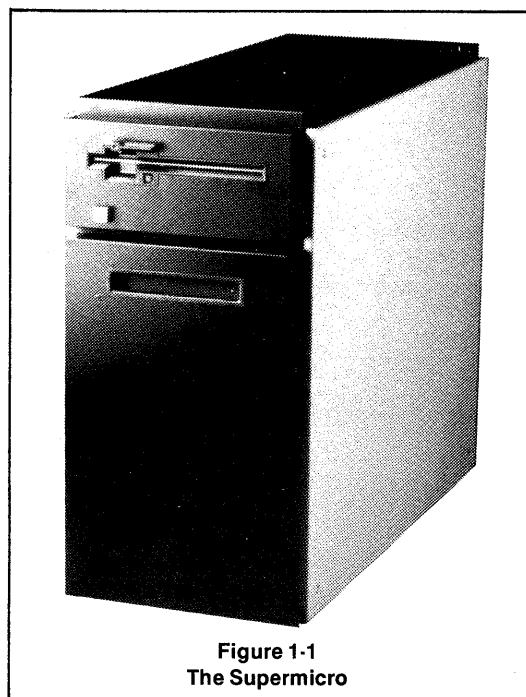

Figure 1-1
The Supermicro

Additional Application Processors may be installed and used as "system resources;" that is, they may be used by anyone desiring to run more than one program at a time. This feature allows you, for example, to compile a long program in a "batch" mode while doing some



other "on-line" task, such as word processing. Also, this feature allows Application Processors in one system to communicate with Application Processors in another system, thereby providing almost unlimited data and resource sharing.

In addition to the basic system configuration, 16-bit Application Processors are available as options. Each of these "Performance Accelerators" uses an 8086-family processor and can support up to one megabyte of memory. These high-performance APs are available to all users as system resources. Your system may support one or more of these Performance Accelerators, depending upon configuration.

The Supermicro incorporates hard disk drives, a diskette drive, and an optional tape backup unit. All components are housed in the Supermicro cabinet.

The m/BUS connects each Application Processor to every other Application Processor and to the File Processor. The File Processor sees that all users have access to all shared peripherals, the hard disk drive(s), the diskette drive, and the "system resource" devices.

1.2.1 File Processor

The File Processor is the Supermicro "manager." The File Processor contains a Z80-family microprocessor, up to 256K-bytes of RAM with parity checking, the diskette controller, the input and output ports for the hard disk and the tape controller boards, and RS232 ports for a system terminal and system printer. The part of the n/STAR Operating System residing in the File Processor uses approximately 32K-bytes of its RAM capacity. The remainder of RAM is used to provide disk buffer pools which the system manages in Multi-User Mode.

The File Processor is mounted under the top-front portion of the chassis cover.

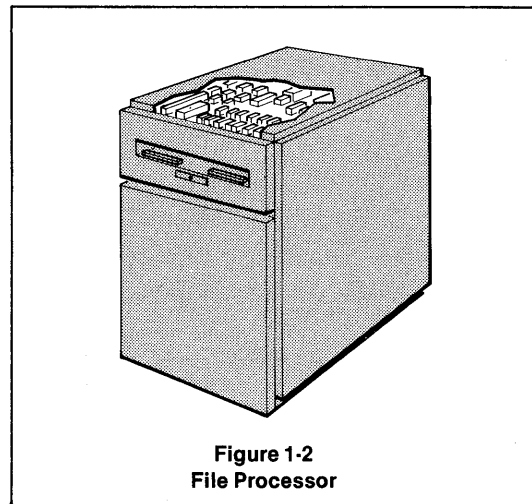
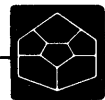

Figure 1-2
File Processor

1.2.2 Application Processors

Each Application Processor provides a user with a single-board computer. The Application Processor card consists of a Z80A microprocessor, 64K bytes of RAM with parity checking, and 2K EPROM. In addition, each Application Processor contains two RS232C serial I/O ports. Custom designed ports can be added to perform special functions.



Each Application Processor is a 4-inch by 9-inch card internally mounted in one of the card slots in the back of the Supermicro. The Application Processors are connected by the m/BUS Interprocessor Link; each AP may be connected to a terminal or to a peripheral, or accessed from another AP.

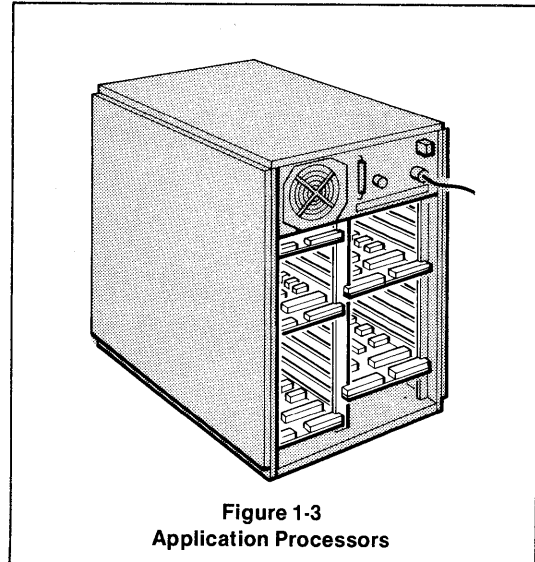

1.2.3 m/BUS Architecture

The m/BUS is a contention bus using a protocol known as Carrier Sense Multiple Access with Collision Detection (CSMA/CD). This approach eliminates the overhead associated with other network architectures such as those based on a polling scheme.

The m/BUS handles the communication between the Application Processors and the File Processor. The unique protocol of the m/BUS allows the Application Processors to communicate directly with other Application Processors without involving the File Processor.

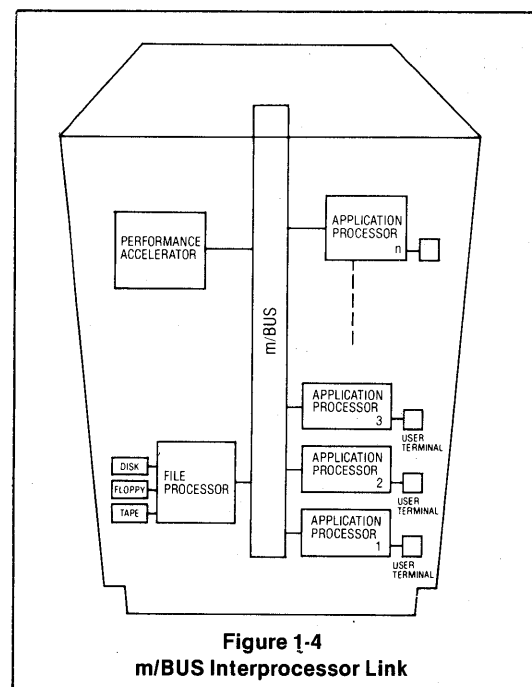



1.2.4 Disk Drives

The Supermicro contains one diskette drive and at least one hard disk drive. The hard disk provides two benefits: greater storage capacity, and faster access time than a diskette. This expanded storage capacity makes the hard disk particularly valuable for work with large files that exceed the limits of a single diskette.

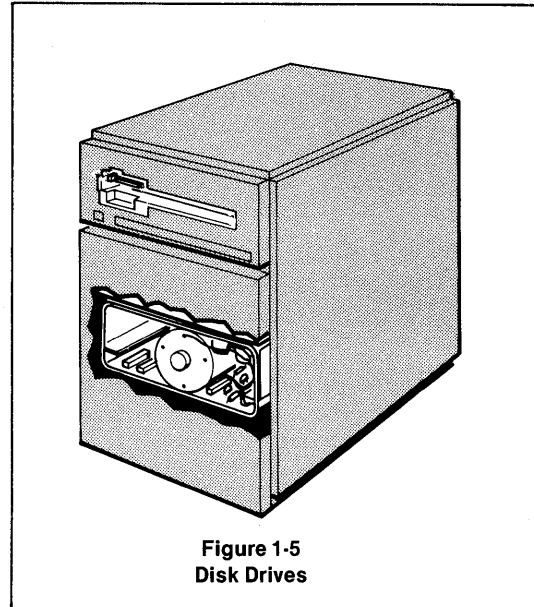

Figure 1-5
Disk Drives

Programs are usually loaded onto the hard disk from diskettes. Data can also be loaded onto the hard disk from diskette, or you can generate data on the computer and store it directly on the hard disk.

The diskette drive is used for operating the Supermicro in diagnostic (single-user) mode, copying information from the hard disk onto backup diskettes, and loading application programs onto the hard disk. The Supermicro uses 8-inch diskettes. See Appendix A for a description of the diskettes used by the different models.

1.2.5 Supermicro Distribution Diskettes

Each Supermicro is shipped with three Distribution Diskettes:

- the n/STAR Distribution Diskette
- the Supermicro Diagnostic Distribution Diskette
- CP/M Operating System Distribution Diskette

Each release of n/STAR and the Diagnostic Utilities is identified with a version number. The version number is printed on each of the Distribution Diskettes.

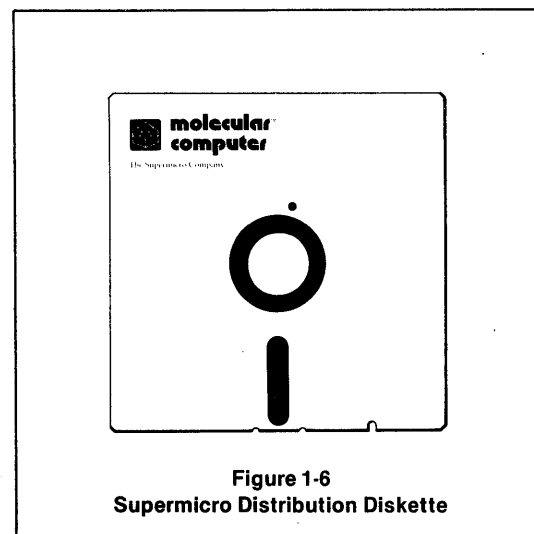

Figure 1-6
Supermicro Distribution Diskette



1.2.6 Tape Backup Unit

The optional Supermicro Tape Backup System is a complete package for backing up data from the hard disk onto tape cartridges.

The tape drive uses a Scotch (R) DC-300XL (or equivalent) tape cartridge which has a capacity of 20 megabytes. The tape operates at a speed of 30 inches-per-second for write/read and 90 inches-per-second for bidirectional search/rewind.

The Tape Backup Utilities are supplied on the Supermicro Diagnostic Distribution Diskette. The Tape Backup Utilities are menu-driven. You may backup information from the hard disk onto tape, restore the information from tape onto the hard disk, and search for a file on the tape.

With the exception of the Supermicro 64X, the tape drive in a Supermicro system is located in the main system cabinet, along with the rest of the computer components. The tape drive slot is on the front panel below the power-on button.

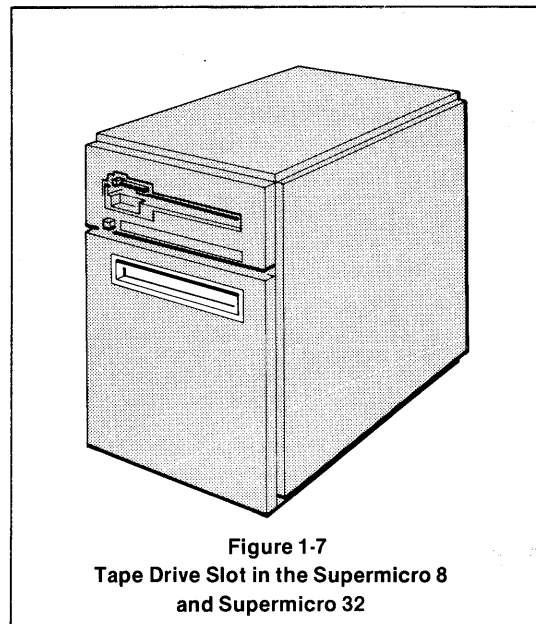

Figure 1-7
Tape Drive Slot in the Supermicro 8
and Supermicro 32

On the Supermicro 64X, the Tape Backup Unit is housed in a second cabinet, either alone or with an additional 32 Application Processor slots and hard disk drive. The tape drive slot is at the top of the front panel.

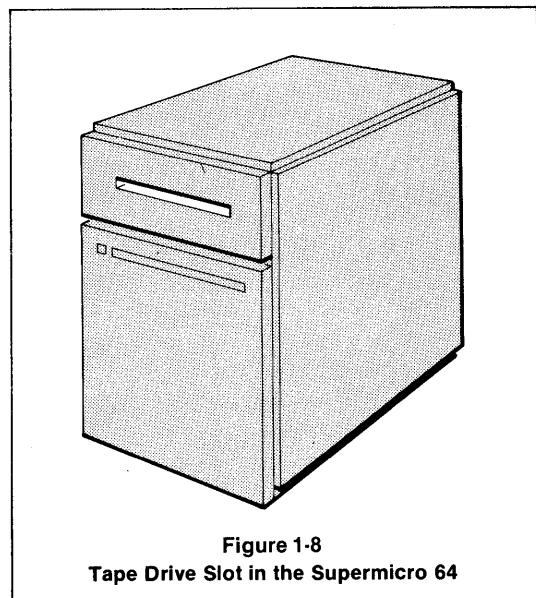

Figure 1-8
Tape Drive Slot in the Supermicro 64



1.2.7 AP/86 Performance Accelerator

The AP/86 Performance Accelerator provides all system users with the power of a 16-bit 8086 CPU and up to one megabyte of RAM. Each AP/86 in a system may be acquired on an as-needed basis for applications requiring very large arrays or complex calculations.

The AP/86 consists of one card with an 8086 microprocessor and up to four cards, each with 256K bytes of RAM. These cards insert into the m/BUS slots, just like any other Application Processor, and connect directly to the m/BUS. One or several AP/86 Performance Accelerators may be installed in your system, depending upon its configuration. Each AP/86 is a shared resource, accessible by any user via a simple menu selection, via a standard Z80 Application Processor. The AP/86 has no external input/output provisions of its own.

1.3 SOFTWARE FOR THE SUPERMICRO

Software for the Supermicro consists of the n/STAR Operating System, Tape Backup Utilities, the Supermicro diagnostic utilities, and the CP/M Operating System.

The n/STAR Operating System allows you to run the Supermicro in multi-user mode taking advantage of all the Supermicro features. You will use the CP/M utilities to operate the system in singler-user mode, to load programs onto the hard disk, and to use the diagnostic utilities.

There is a release number associated with each version of the Supermicro software. The version number is printed on the Distribution Diskette and is displayed on the screen each time the system is turned on.

1.3.1 n/STAR Operating System

n/STAR has been designed to allow many application processors operating independently to share files and peripherals and to communicate with each other in a highly efficient manner. n/STAR incorporates all the features of the CP/M Operating System and also supplies enhancements to facilitate writing of programs for multi-user applications. n/STAR provides a data security system giving password protection to files.

With optional AP/86 Performance Accelerators installed, n/STAR is compatible with both CP/M and CP/M-86. This enables Supermicro users to choose from the extensive CP/M application library and the growing CP/M-86 library.

n/STAR has been designed specifically for the multi-processor computer systems manufactured by Molecular Computer. Each Supermicro is shipped with n/STAR installed in the hard disk.

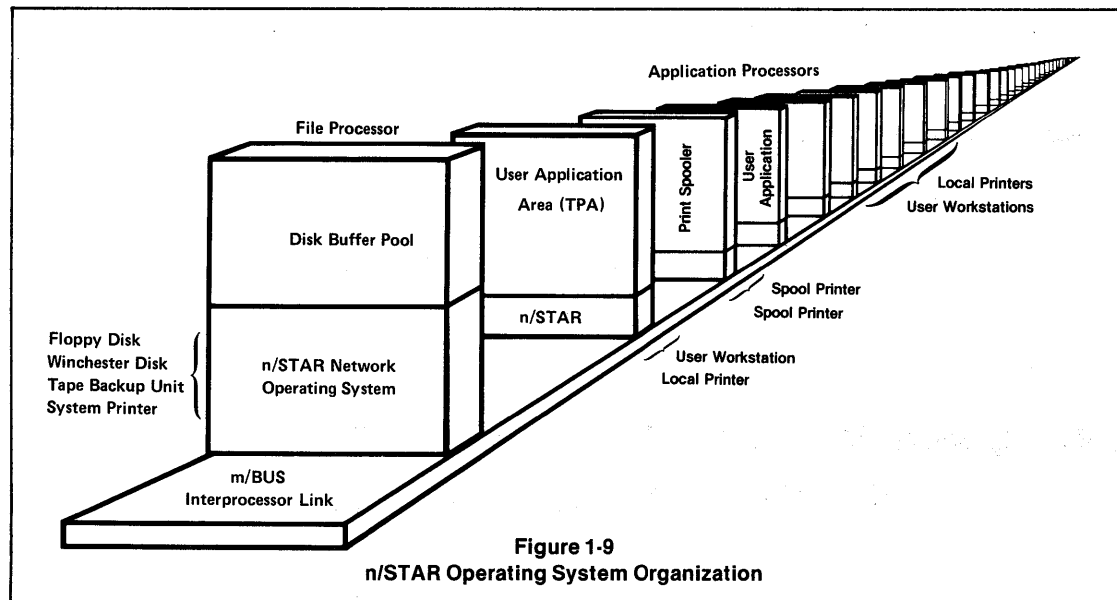

1.3.2 Diagnostic Utilities

The diagnostic utilities allow the maintenance user to format, diagnose, and exercise the hardware. The diagnostic utilities are:

- | | |
|---------|--|
| DKM | Formats and verifies diskettes. |
| GENSTAR | Installs a release of n/STAR on the hard disk. |
| SYSINT | Formats, verifies, and initializes the hard disk. |
| GPMON | Exercises and tests the memory locations. |
| DSD | Verifies the operation of the m/BUS and the communication between the application processors and the file processor. |

1.4 SUPERMICRO MODELS

Molecular Computer offers several models in the Supermicro series. The standard Supermicro series includes a File Processor with a Z80 CPU, 64 KBytes RAM with parity, .5 MByte 8" diskette drive, the specified hard disk drive, and the capability to add the specified number of users (Application Processors).

1.4.1 Supermicro 8

- MICRO 10-8 8-user, 10 MByte hard disk
- MICRO 15-8 8-user, 15 MByte hard disk



1.4.2 Supermicro 32

- MICRO 35-32 32-user, 30 MByte hard disk
- MICRO 70-32 32-user, 60 MByte hard disk

1.4.3 Supermicro 32X

- MICRO 60-32 32-user, 60 MByte hard disk, enhanced system

1.4.4 Supermicro 64X

- MICRO 136-32 32-user, 136 MByte hard disk, enhanced system, expandable to 64 users

You may use any of the systems in Diagnostic (single-user) Mode without any additional components, other than an RS232C-type terminal and connection cable.

1.5 SUPERMICRO APPLICATION PROCESSORS

To operate in Multi-User Mode, you must add an Application Processor for each terminal (user), including the first user. (You cannot operate the system in Multi-User Mode from the File Processor.

Several types of Application Processors are available, depending upon your specific needs. Note that the standard Application Processors and the X-series Application Processors are not interchangeable. Unless otherwise noted, these Application Processors each have a Z80A CPU, 64 KBytes of RAM with parity, and use one "user" slot in the computer.

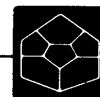

1.5.1 Standard Supermicro Series Application Processors

- AP 8001 Two RS232C asynchronous ports, up to 9600 bps
- AP 8003 Two RS232C asynchronous ports, up to 19,200 bps
- AP 8011 Two RS232C synchronous ports, up to 50,000 bps
- AP 8015 Two RS232C ports, switch selectable asynchronous (up to 19.2 Kbps) and synchronous (up to 50 Kbps)
- AP 8601 8086 CPU w/256 KBytes RAM, uses two slots
- MM 8256 256 KBytes RAM add-on for AP8601, uses one slot, maximum configuration: 3 units (1 MByte RAM total)

1.5.2 Supermicro X Series Application Processors

- AP 8020 Two RS232C ports, switch selectable asynchronous (up to 19.2 Kbps) and synchronous (up to 50 Kbps)
- AP 8620 8086 CPU with 256 KBytes RAM, uses two slots
- MM 8620 256 KBytes RAM add-on for AP8620, uses one slot, maximum configuration: 3 units (1 MByte RAM total)

1.6 SUPERMICRO OPTIONS

In addition to the standard hardware configuration and Application Processors, you may add several options to your Supermicro system. We've listed the options available for each of the systems previously described. Unless otherwise noted, all options are field-installable and are housed within the existing cabinet.

1.6.1 Supermicro 8 Options

- MICRO 10-D provides 10 MByte hard disk for MICRO 10-8. Two units may be added for total of 30 MBytes
- MICRO 15-D provides 15 MByte hard disk for MICRO 15-8. Two units may be added for total of 45 MBytes
- MICRO 20-T provides 20 MBytes streamer tape backup



1.6.2 Supermicro 32 Options

- MICRO 35-D1 provides 30 MBytes hard disk and additional cabinet for MICRO 35-32
- MICRO 35-D2 provides 30 MBytes hard disk to be added to MICRO 35-D1. Two units may be added for a total of 120 MBytes
- MICRO 70-D1 provides 60 MBytes hard disk and additional cabinet for MICRO 70-32
- MICRO 70-D2 provides 60 MBytes hard disk to be added to MICRO 70-D1. Two units may be added for a total of 240 MBytes

1.6.3 Supermicro 32X Options

- MICRO 60-D1 provides 60 MBytes hard disk and additional cabinet for the MICRO 60-32
- MICRO 60-D2 provides 60 MBytes hard disk to be added to MICRO 60-D1. Two units may be added for a total of 240 MBytes
- MICRO 20-T provides 20 MBytes streamer tape backup

1.6.4 Supermicro 64X Options

- MICRO 136-32T provides 20 MBytes streamer tape backup, 136 MByte hard disk, Z80B File Processor with 256 KBytes RAM, all in a cabinet with an additional 32 m/BUS slots, expanding the system to a total user capacity of 64, with a total disk drive capacity of 272 MBytes
- MICRO 0-0T provides 20 MByte streamer tape in a separate cabinet



1.7 ADDING TERMINALS AND PRINTERS TO THE SUPERMICRO

The File Processor and each Application Processor (with the exception of the AP/86) has two serial output ports. The serial output ports provide connection to terminals, printers, or other peripherals with an RS232C interface.

Before your Supermicro will operate, you must attach at least one terminal to one of the RS232C ports. If you attach a terminal to the File Processor, the Supermicro operates in Diagnostic Mode. Diagnostic Mode is normally used for file and system maintenance, tape backup, and formatting diskettes.

If you attach one or more terminals to Application Processors, the Supermicro operates in Multi-User Mode, and all users can access the system resources.

Adding a printer to your Supermicro allows you to take advantage of n/STAR's printing capabilities. A printer attached to the File Processor becomes a system printer shared by all the users. Printers attached to dedicated Application Processors are used for print despooling. And a printer attached to a user's Application Processor becomes a dedicated local printer, accessible only by that user.

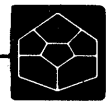

INSTALLATION

2

This chapter provides information for locating and installing the Supermicro hardware. It tells how to unpack the equipment, prepare the system for operation, connect terminals and printers, and perform an operational check of the system.

2.1 SITE PREPARATION

In preparing for the installation of a Supermicro computer system, one should take into account the system's space requirements, power requirements, environmental factors, and cabling considerations. Each of these matters is discussed in the following sections.

2.1.1 Space Requirements

Figure 2-1 shows the minimum amount of space needed for the computer. Note that:

- The cabinet's 25-inch height lets you place the computer under a table to conserve floor space.
- At least six inches of clearance is required in front and in back of the cabinet for adequate ventilation and for cable connections.

It is important, also, to:

- Place the unit so that cables and application processor modules can be readily installed or removed at the rear of the cabinet. (Note that the rear cover must be removed to get at the plug-in modules.)
- Route all external cables so they will not interfere with foot traffic (see Section 2.1.4).

The above space requirements also apply to the optional Supermicro auxiliary units using the same size cabinet as the computer. This includes the Supermicro 64X (MICRO 136-32) and its expansion unit.

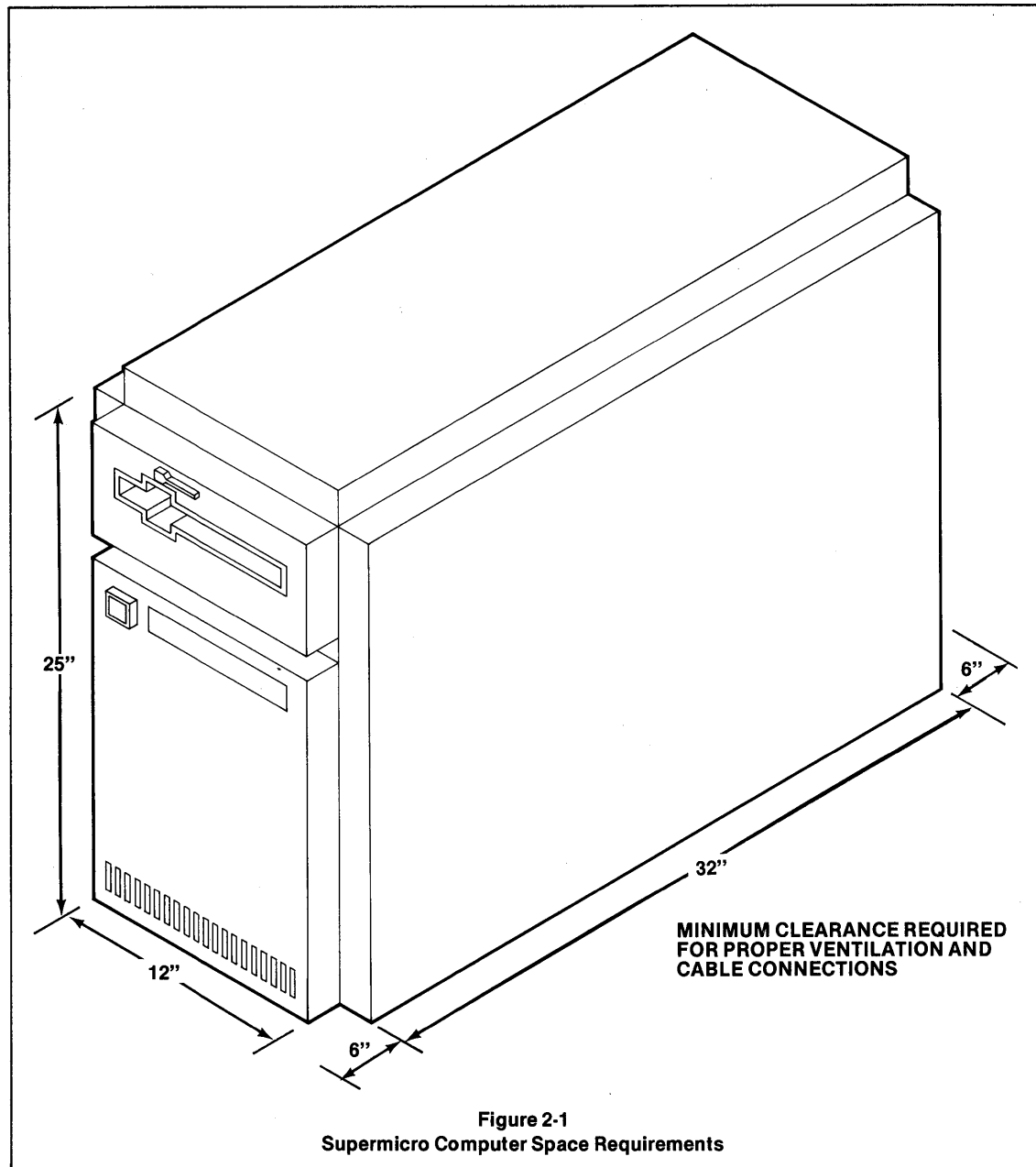

2.1.2 Power Requirements

The Supermicro computer system requires no special electrical setup. It does require:

- A three-prong, grounded electrical power outlet.
- An AC power source that will supply 3 to 9 amperes (at 110/120 volts). The amount of current required depends on the system model, number of users, and equipment options included. It is a good idea, before using any AC outlet, to add up the electrical power required for all equipment connected to that circuit and compare the total with the rating (in amperes or watts) for the corresponding circuit breaker.



If possible, avoid installing the system near heavy machinery, such as a printing press or arc welder, that operates with large power surges. Such conditions could affect the system's performance. If the situation cannot be avoided, you may have to take steps to ensure proper electrical isolation. Consult your field representative for further information.

2.1.3 Environmental Requirements

The Supermicro system has been designed for use in the modern office and has no unusual environmental requirements. To ensure optimum performance, follow these guidelines:

- Provide space for adequate air flow around the cabinet. Avoid locating the system in a completely enclosed space, such as a closet.
- Operate the system with all cabinet covers in place.
- Do not let the room temperature exceed 90°F (32°C)
- Avoid placing the computer on carpeting. This will reduce the chances of static discharge damaging the equipment. If you cannot avoid carpeting, use a non-static mat under the cabinet. These mats can be purchased from most computer supply houses.

2.1.4 Cabling Considerations

If the system being installed has a large number of application processors, you should plan your cable layout so as to run the terminal and printer cables neatly, efficiently, and with personnel safety in mind. Doing the following should help.

- Plan your computer system layout on a floor plan of the work area. Take into account the location of all work stations and office equipment, and consider the foot traffic patterns.
- Look through office and computer supply catalogs for ideas and materials that will help you attain a satisfactory installation.

2.2 UNPACKING

Before you unpack the equipment, check the shipping container for signs of possible damage to the equipment during transit. If you find any damage, notify the carrier immediately. Be sure to save the shipping container, since it must be available for inspection by the carrier if you file a claim.

To unpack the equipment, do the following:

1. With a pair of diagonal cutters, clip the metal bands that hold the container together. **BE CAREFUL**—the bands are very taut and can snap out sharply when cut.
2. Lift off the top section of the container.
3. Remove from the top of the computer cabinet:
 - a. The system manual (containing three Distribution Diskettes).



- b. Shipping checklist
 - c. Out-of-Box Report
4. Remove the sides of the container by pulling straight up.
 5. With another person to help, lift the computer out of the bottom section of the container and set it down on a flat surface in a convenient place for inspection and checkout.
 6. Remove the power cord from the bottom of the shipping carton.
 7. Check the shipping list to make sure nothing is missing. (The application processors may be installed in the back of the computer cabinet.)
 8. Complete the Out-of-Box Report and mail it to Molecular Computer.

2.3 SYSTEM SETUP

After the Supermicro system is unpacked, you can set it up for operation by taking the necessary preparatory steps and connecting the terminals and printers as outlined below.

2.3.1 Initial Preparation

Before you connect any external equipment to the system, do the following:

1. Remove the flat cardboard protector from the slot at the front of the diskette drive (see Figure 2-2 or 2-3).
2. Take the left and right side panels off the computer cabinet by removing the four screws that hold each panel in place.
3. Take the back cover off the cabinet by removing the two screws that hold the cover in place.
4. Check to see that the application processor cards at the back of the computer are properly seated. If any seem to be loose, push them in gently but firmly until they are properly seated.
5. Take the top cover off the cabinet by removing the four screws that hold the cover in place.
6. If your system is a Supermicro 8 or Supermicro 32, check the power connections at the power distribution panel (see Figure 2-2) to make sure they are correct for the AC voltage you are using. Figure 2-4 shows the proper connections for 110/115 volts and for 220/240 volts.

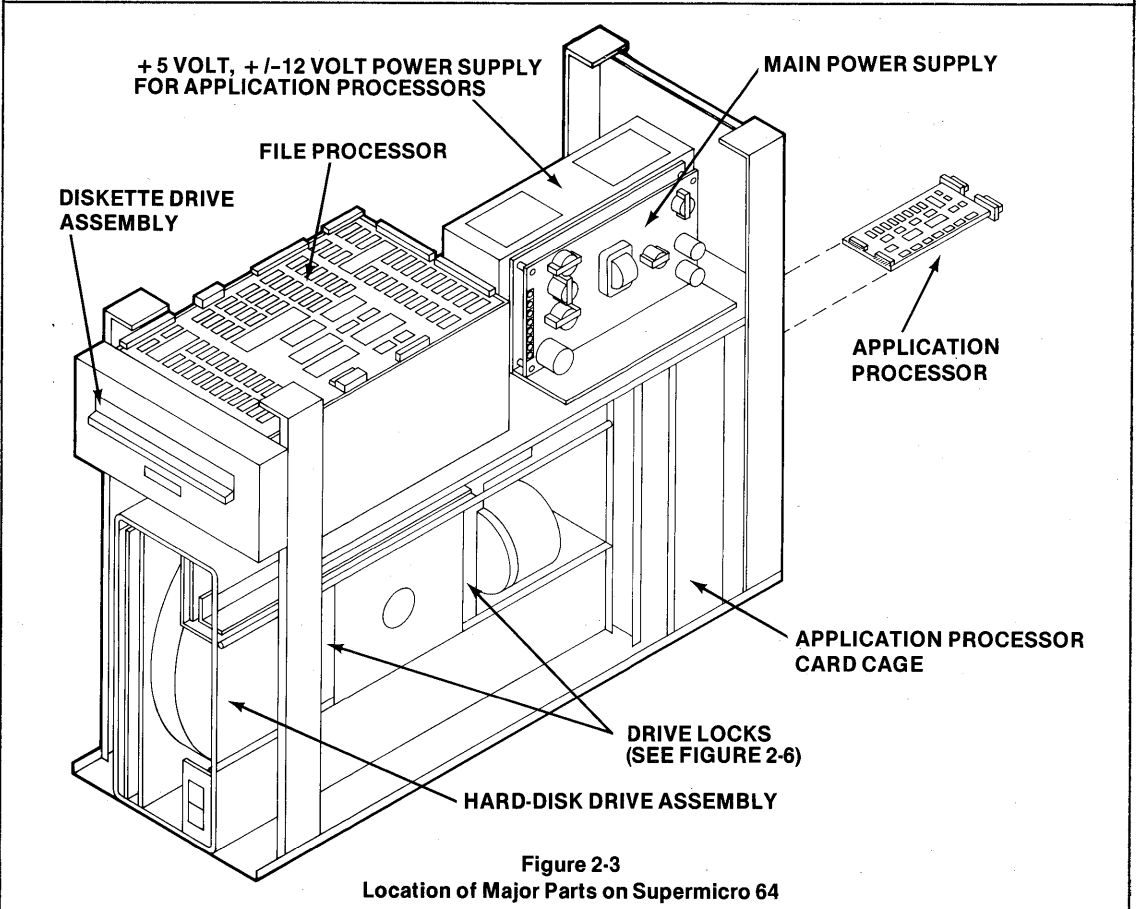
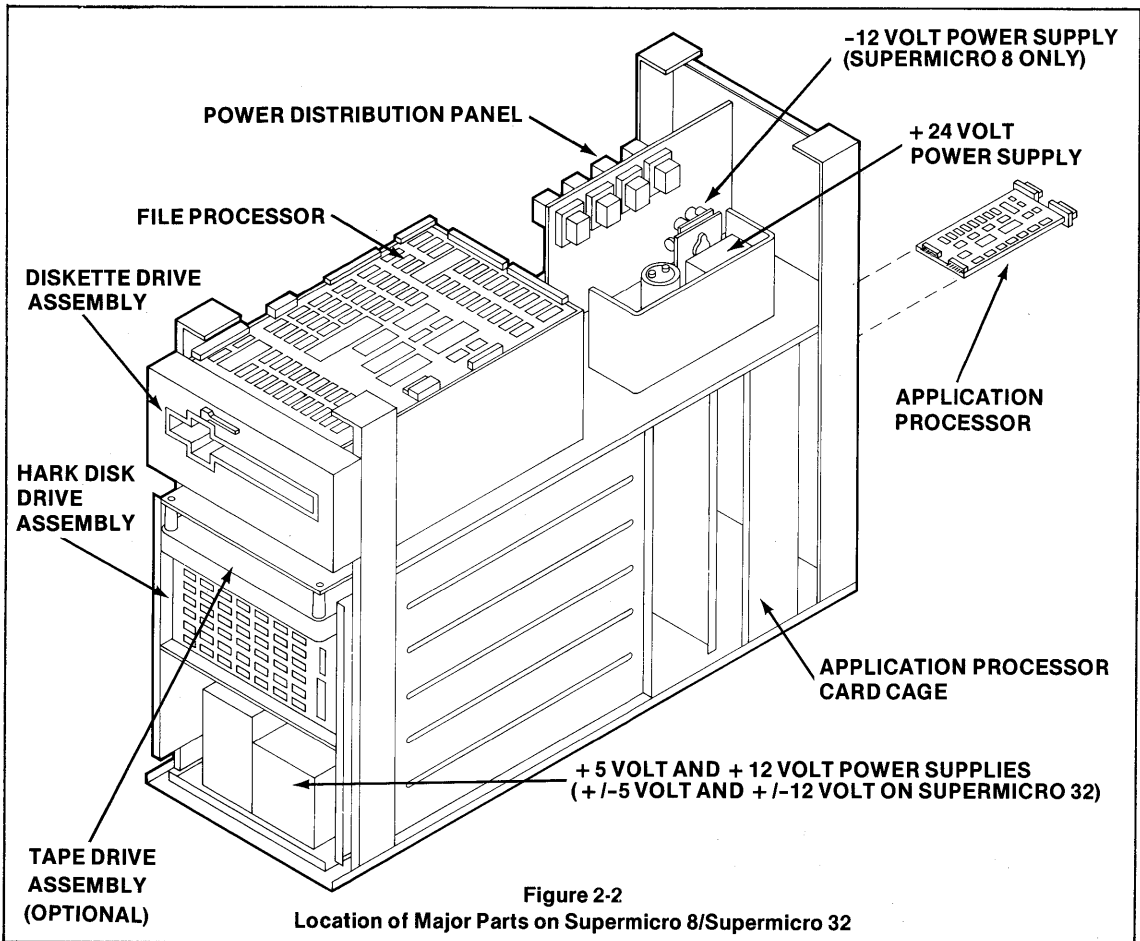

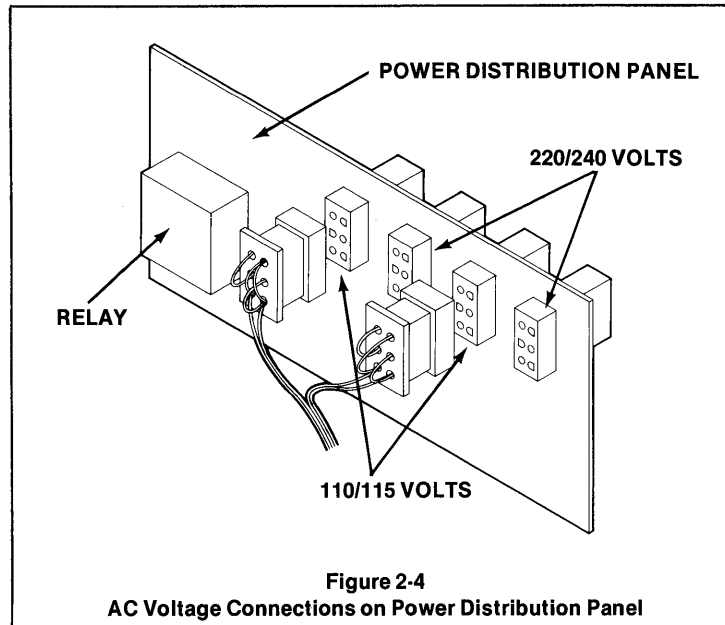

7. Inspect the inside of the unit for any obvious signs of damage. Look for such things as:
 - Cracked or broken circuit boards.
 - Loose connections or broken wires.
 - Loose or missing hardware.
8. If your system is a Supermicro 32 or Supermicro 64, unlock the hard-disk drive as follows (the Supermicro 8 does not require unlocking):
 - a. The Supermicro 32 has a single locking lever at the rear of the drive assembly as shown in Figure 2-5. Reach in through the vertical opening in the left side of the cabinet (as viewed from the rear) and move the lever to the "unlocked" position by pushing it down and to the left.

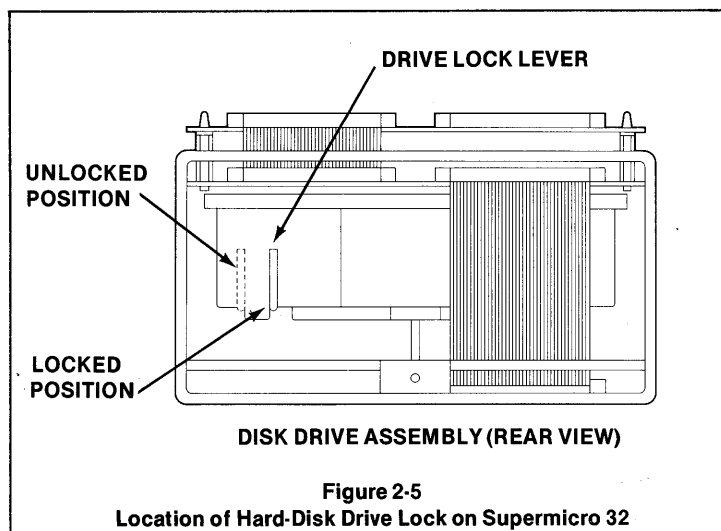

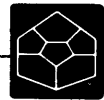

- b. The Supermicro 64 has two separate drive locks located at the left side of the unit (as viewed from the rear) as shown in Figure 2-6. Move each lock lever to its “unlocked” position.

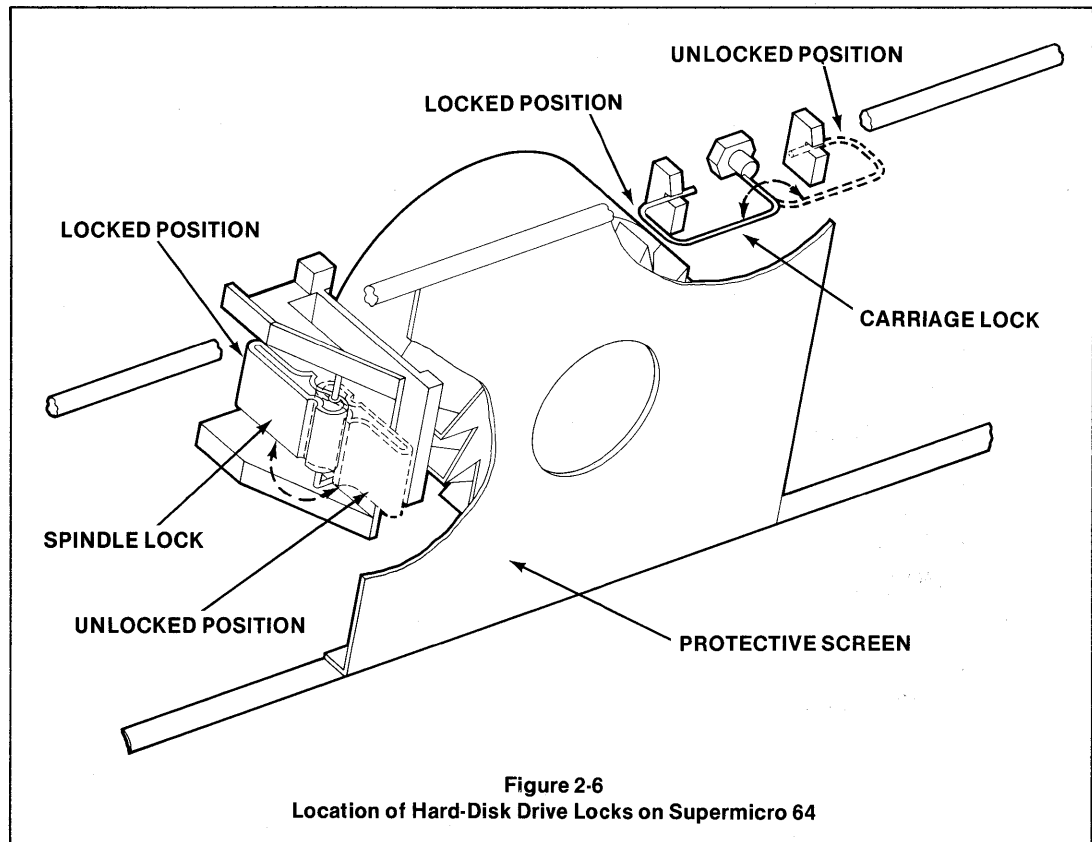

Figure 2-6
Location of Hard-Disk Drive Locks on Supermicro 64

CAUTION

Always lock the disk drive before moving the unit, as a precaution against possible damage to the drive. On the Supermicro 64, be sure to lock both the drive spindle and the carriage.



2.3.2 Terminal and Printer Connections

The Supermicro system supports standard ASCII RS232C terminals and printers. As shown in Figure 2-7, each application processor has two RS232C ports with 25-pin (DB-25) connectors to which the external devices may be connected. There are also two DB-25 connectors on the upper rear panel of the computer for connecting a terminal and a printer to the system file processor.

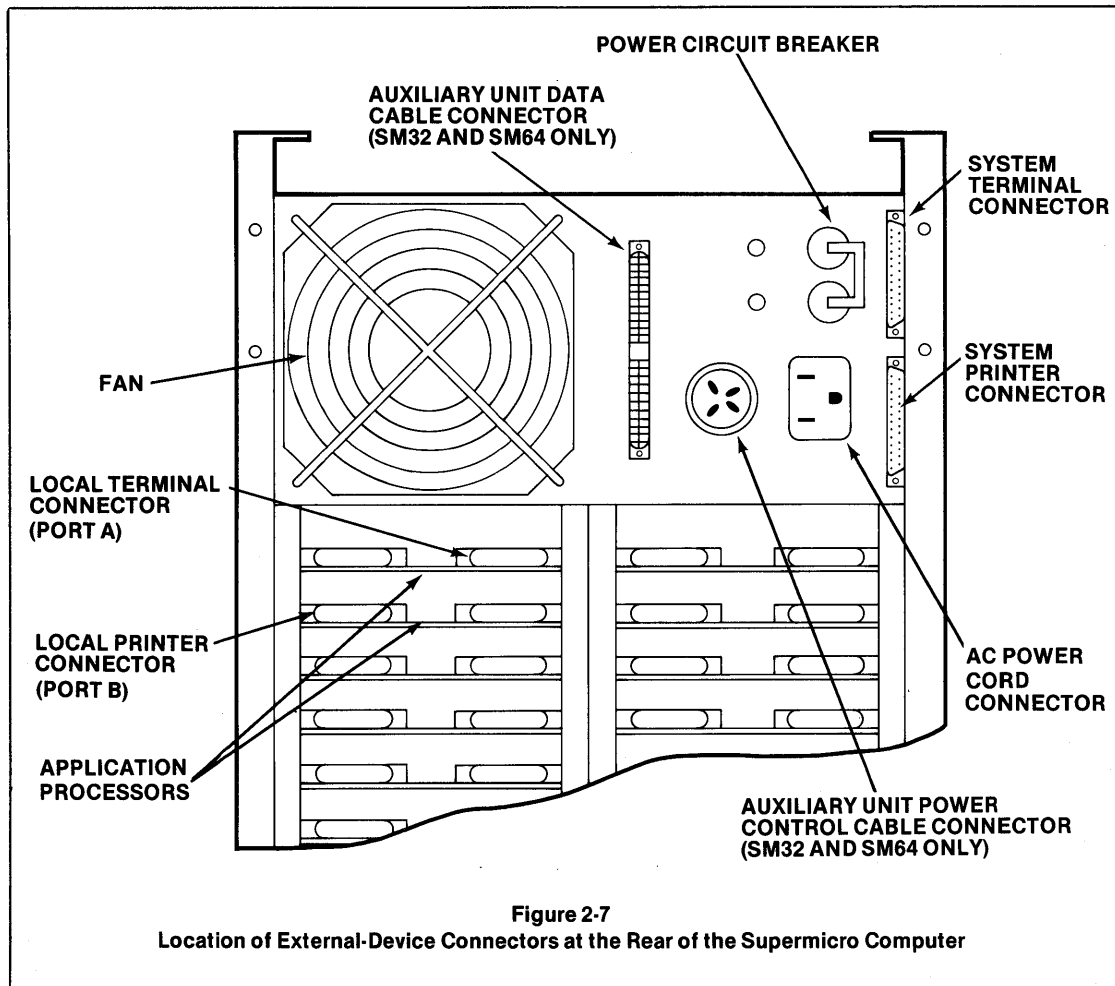

Figure 2-7
Location of External-Device Connectors at the Rear of the Supermicro Computer

The standard AP-8001 and AP-8003 application processors support the asynchronous data transmission protocol. The interface cable required to connect an external device to these processors depends on the type of device and the model, as described later.

To connect your terminals and printers to the Supermicro system, do the following.



Terminal Connections

1. Set the RS232 switches on the terminal for the following n/STAR parameter values (refer to the terminal manual for details):

Parameter	Value
Duplex	Full
Parity	None
Data bits	8
Start bits	1
Stop bits	1
Baud rate	9600

Note that the baud rate of 9600 is the n/STAR default value for the application processor terminal port. The baud rate can be changed as described in Sections 6.3.4 and 6.4.5.

2. Obtain a cable consisting of two standard RS232 male connectors (type DB-25) with the corresponding pins listed in Table 2-1 connected by wires.

RS232 Connector Pin Number	Signal
2	Transmit data (TXD)
3	Receive data (RXD)
7	Signal ground

3. Connect one end of the interface cable to the terminal. Refer to the terminal instruction manual for information on connecting the cable, turning on the terminal, adjusting screen brightness, and so on. Connect the other end of the cable as follows:

Multi-user Mode—Plug in to the right-hand connector, as viewed from the rear, on the application processor (port A in Figure 2-7).

Diagnostic Mode—Plug in to the upper DB-25 connector on the upper rear panel of the computer (system terminal connector in Figure 2-7). Note that in diagnostic mode, any terminal connected to an application processor will not function in the system. By the same token, a terminal plugged into the system terminal connector will not function with the system in multi-user mode.



Printer Connections

1. Set the RS232 switches on the printer for the following n/STAR parameter values (refer to the terminal manual details):

Parameter	Value
Parity	None
Data bits	8
Start bits	1
Stop bits	1
Baud Rate	9600
DTR (Data Terminal Ready)	On

Note that the baud rate of 9600 is the n/STAR default value for the application processor printer port. The baud rate can be changed as described in Sections 6.3.4 and 6.4.5.

2. Obtain an interface cable consisting of two standard RS232 male connectors (type DB-25) with pins wired according to the signal lines supported by both the computer and the printer. The n/STAR operating system supports only the printer port lines specified in Table 2-2.

RS232 Connector Pin Number	Signal
2	Transmit data (TXD)
3	Receive data (RXD)
7	Signal ground
20	Data terminal ready (DTR)

The n/STAR system will not send data to the printer unless DTR is on. If your printer does not support DTR, you can wire any other RS232 pin that is always on to the DTR pin (20) on the computer. In that case, however, the printer port baud rate must be set to a value no higher than the actual operating speed of the printer to avoid data overrun.

The TXD line is used for XON/XOFF and ETX/ACK protocols. If your printer does not use either of these protocols, you do not have to wire the TXD pins (2) on the interface cable connectors.

Note that some printers, in order to work, require that certain RS232 signal lines not supported by the computer be active. In such cases, the problem can often be solved by connecting jumpers between two or more pins, as appropriate, on the connector which attaches to the printer.

Example: A printer that supports DTR (pin 20) requires that its DSR input line (pin 6) be held on during the operating cycle. To use this printer with the Supermicro system, connect a jumper wire between pins 6 and 20 on the printer RS232 connector.

Appendix E describes the interface cable wiring for a number of commonly used printers.

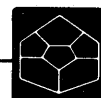

3. Connect one end of the interface cable to the printer. Refer to the printer instructions for information on how to connect the cable, turn on the printer, and so on. Connect the other end of the cable as follows:

Local Mode—Plug in to the left-hand connector, as viewed from the rear, on the application processor (port B in Figure 2-7). A printer so connected is dedicated to that processor (see Section 6.6.1).

System Mode—Plug in to the lower DB-25 connector on the upper rear panel of the computer (system printer connector in Figure 2-7). A printer so connected may be used by any processor in the system (see Section 6.6.2).

Spooling Mode—Plug one or two printers into either or both connectors on the dedicated (spooling) application processor (ports A and B in Figure 2-7). A printer so connected may be used by any processor in the system (see Section 6.6.3).

2.3.3 Final Preparation

After the terminals and printers have been connected to the computer, do the following:

1. Replace the back cover on the computer cabinet, routing the terminal and printer interface cables down inside the unit so that they come out through the opening at the bottom of the cover.
2. Replace the top cover on the cabinet and fasten it with the four mounting screws.
3. Replace the side panels on the cabinet and fasten each with its four mounting screws.
4. Connect the appropriate end of the power cord to the AC power connector on the upper rear panel of the computer cabinet (see Figure 2-7). Connect the other end of the power cord to a properly grounded (three-prong) AC outlet.

The system is now ready for a functional check as described in Section 2.4

2.4 CREATING BOOTABLE SYSTEM DISKETTES

The n/STAR and Diagnostic Diskettes supplied with your system are not bootable; that is, they cannot be used as is to bring up the system. To make these diskettes bootable, you must copy the CP/M operating system and utilities from your CP/M Distribution Diskette to both your n/STAR and Diagnostic Distribution Diskettes.

Follow this procedure to create bootable n/STAR and Diagnostic system diskettes from the three diskettes supplied with your Supermicro system.

1. Configure the system for Diagnostic Mode as described in Section 3.4.
2. Insert your CP/M Distribution Diskette in the diskette drive.



3. Press
BREAK
to boot the system.
4. Type
SYSGEN
Press RETURN.
5. The screen displays

SYSGEN VER n.n
SOURCE DRIVE NAME (OR RETURN TO REBOOT)
6. Type
A

(do not press RETURN). The screen displays
SOURCE ON A, THEN TYPE RETURN
7. Press
RETURN

The screen displays
FUNCTION COMPLETE
DESTINATION DRIVE NAME (OR RETURN TO REBOOT)
8. Remove the CP/M Distribution Diskette and insert the n/STAR Distribution Diskette.
9. Type
A

(do not press RETURN). The screen displays
DESTINATION ON A, THE TYPE RETURN



10. Press

RETURN

The screen displays

```
FUNCTION COMPLETE
DESTINATION DRIVE NAME (OR RETURN TO REBOOT)
```

11. You may now repeat steps 8-10 to copy boot tracks to additional n/STAR and Diagnostic Distribution Diskettes, if desired.
12. When you are finished creating bootable system diskettes, place one of your new bootable diskettes into the diskette drive. Press

BREAK

to boot the system. If the boot tracks on the diskette are valid, the screen will display

```
Supermicro*xx yyMB Diagnostic Diskette

zzK CP/M Vn.n
A>
```

Either of these bootable system diskettes will now boot the system in Diagnostic Mode. You will most often use the Diagnostic Diskette for routine system backup and file maintenance. You should need the n/STAR system diskette only when upgrading the system to a newer revision of the operating system or when replacing the hard disk drive that contains the operating system.

2.5 SYSTEM CHECKOUT

To check the functioning of the system, go through the procedures described in Sections 3.3, 3.4, and 3.5.

CAUTION

Be sure that the hard-disk drive on the Supermicro computer is unlocked as described in Section 2.3.1 before you apply power to the system. The drive could suffer damage otherwise.

If in the course of the checkout, the terminal displays an error message such as

```
MSM DOES NOT RESPOND
```

try resetting the system (see Section 3.8).



SUPERMICRO OPERATION

3

This chapter explains how to use the Supermicro once installation is complete. If you need information on installing the hardware or connecting a peripheral, please read the instructions in Section 2.3.2.

3.1 DISK UTILIZATION

The Supermicro includes one diskette drive and at least one hard disk drive. The diskette drive is used for operating the Supermicro in single-user (diagnostic) mode, copying information from the hard disk onto backup diskettes, and loading application software onto the hard disk.

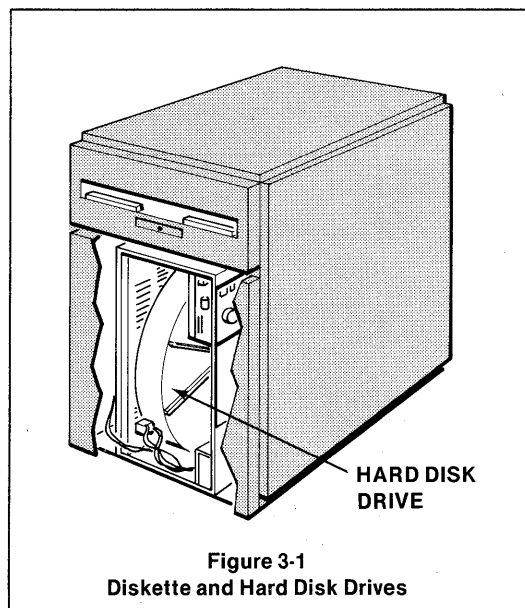

Figure 3-1
Diskette and Hard Disk Drives

The hard disk contains the n/STAR operating system, the application programs, and the data files. A loading procedure is not required each time the Supermicro is turned on. The programs you place on the hard disk will remain there until you remove them. Data can be loaded onto the disk from diskette, or you can generate data on the computer and store it directly on the hard disk.

The hard disk is not removable. Each hard disk in the Supermicro is permanently installed; you do not handle, label, or store it as you would a diskette. The hard disk is vulnerable to damage from impact, so it is important to prevent the Supermicro from being dropped or bumped.

3.2 INSERTING DISKETTES

Fingerprints, dust, or scratches on the diskette surface can destroy information stored on the diskette. Always handle the diskette with care. For more information on the proper treatment of diskettes, refer to the manufacturer's literature.

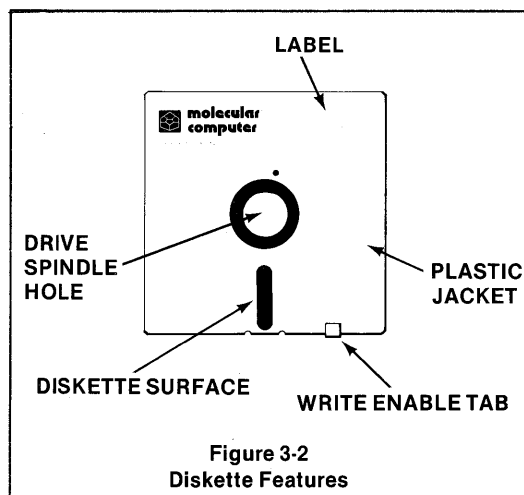
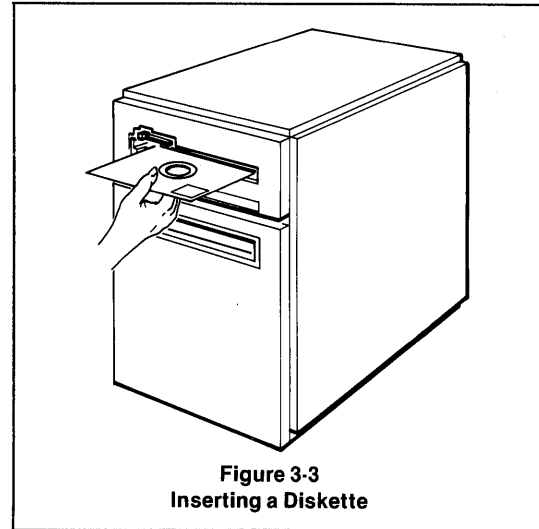

Figure 3-2
Diskette Features



With the Supermicro turned on, open the diskette drive by pressing the latch. Slide the diskette carefully into the opening. The label should face up, on the edge toward you.



Push the diskette in gently. If you encounter more than slight resistance, pull the diskette out carefully and start again. The diskette is flexible and you may damage it if you try to force it into the diskette drive.

Push the diskette into the disk drive until you hear a click and feel the diskette hit the back of the slot. Close the disk drive by pushing down the door latch.

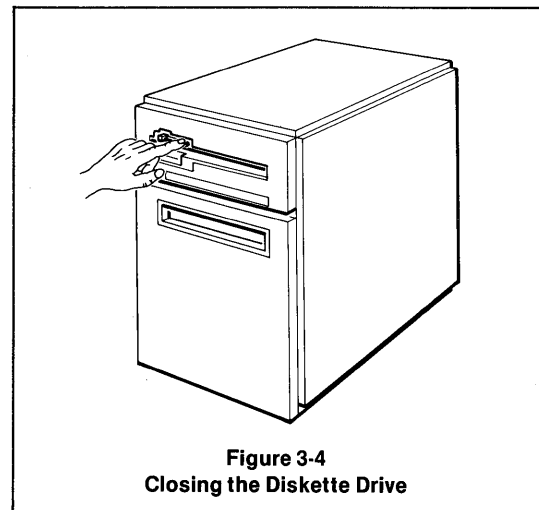

The light on the diskette door latch indicates that the read/write head is in contact with the diskette. Do not remove the diskette from the drive slot while the indicator light is on. If you take the diskette out of the drive while the head is on the diskette, you may destroy information on the diskette.

3.3 GOING INTO MULTI-USER MODE

Follow the procedure described in this section every time the system is turned on for multi-user operation. Note: To operate the Supermicro in multi-user mode, you must use a terminal attached to one of the application processors. Section 2.3.2 describes the cabling configuration for multi-user mode.



Before turning on the power to the computer, make sure the terminal you will be using is turned on and the diskette drive is empty.

The computer's power-on button is on the front panel below the diskette drive slot. Press it firmly. A power indicator light in the button will light up.

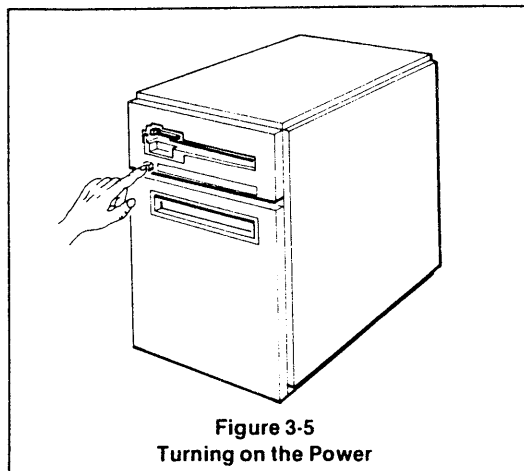

Figure 3-5
Turning on the Power

As the power goes on the fan begins to whir. The message

```
xxx INITIALIZING...
```

appears in the upper left hand corner of the screen. xxx is the unit address of the terminal's application processor. If the message and the cursor are not visible adjust the brightness of your terminal.

The disk-startup sequence will take about 30 seconds. The terminal will then display

```
- n / S T A R -  
(c) 1982 Molecular Computer  
64K Z80 Vn.nn UNIT = xxx
```

Vn.nn is the n/STAR version number and xxx is the unit address of the application processor for that terminal.

The next screen will display the Molecular Computer logo (or your own customized message) and a prompt for your user ID. You are now ready to log on to the n/STAR operating system. See Section 6.3.1.



3.4 GOING INTO DIAGNOSTIC MODE

The procedure described below should be followed every time the Supermicro is turned on in diagnostic mode. Note: To put the Supermicro in diagnostic mode, you must operate the system from a terminal attached to the file processor. Section 2.3.2 describes the cabling configuration for diagnostic mode.

CAUTION

If you are switching between multi-user and diagnostic modes, leave the power on while making the hardware adjustments. If you should execute the DOWN command, wait at least 60 seconds after the power-on light goes off before you move the terminal connectors.

Press the power-on button. Insert the Diagnostic Diskette or the n/STAR Diskette into the diskette drive slot. Close the drive door. See Figure 3-6.

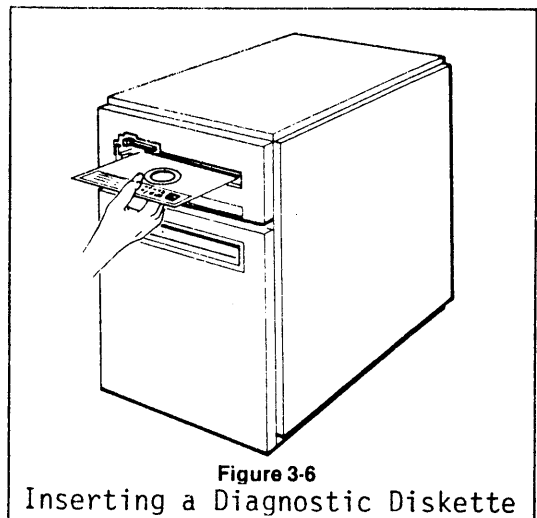

Figure 3-6
Inserting a Diagnostic Diskette

Note

To run in Diagnostic Mode, you must start with a bootable Diagnostic or n/STAR Diskette. To learn how to create a bootable diskette from the Distribution Diskettes, refer to Section 2.4.

Press BREAK. The Supermicro loads a version of CP/M and the diagnostic utilities into the file processor's RAM from the Distribution Diskette. The screen will display

```
Supermicro*xx yyMB Diagnostic Diskette
```

```
zzK CP/M Vn.n  
A>
```

where xx is the model number of your Supermicro, yy is the hard disk storage capacity, zz is the size of CP/M, and n.n is the version number of CP/M.

See Chapter 5 for a description of the Tape Backup System and Chapter 4 for a description of diagnostic mode.



NOTE

This manual refers to the BREAK key as any keystroke or combination of keystrokes on the terminal key pad that will reset the processor. A processor on the Supermicro will be reset if the TXD line of the terminal's EIA port is set to high for longer than 50 ms.

The ADDS terminal, for example, requires a CTRL-BREAK to reset the processor. Consult your terminal's literature to determine the keystroke that will perform this function.

3.5 TURNING OFF THE POWER

CAUTION

The circuit breaker on the upper-right corner of the back panel will turn the power off at any time. *Do not* use this switch to turn off the system unless there is an emergency. If you turn off the power to the system with the circuit breaker, you may destroy information on the hard disk.

3.5.1 Power Off in Multi-User Mode

To turn off the power when in multi-user mode, type

DOWN

from a terminal connected to any application processor. If no users are logged onto the system, and no processes are running, the disk drive(s) will begin the power down cycle. After about 30 seconds, the power will automatically disconnect and the indicator light in the power-on button will go off.

If there are users on the system, or if a file is open (for example, a spooling printer is printing), the screen will display the user ID and terminal number of each logged-on user. The system will not shut down until all users have logged off and all files are closed. You may retry the DOWN command by pressing any key, or you may cancel you DOWN request by pressing CTRL-C.

If the screen displays a question mark (?) in response to the DOWN command, you do not have the program DOWN.COM in the volume SYSTEM (see Section 6.9 for a description of the SYSTEM volume).



3.5.2 Power Off in Diagnostic Mode

To shut down the system in Diagnostic Mode, make sure the bootable n/STAR or Diagnostic Diskette is in the diskette drive, then type

DOWN

from the terminal connected to the file processor (port A). The disk drive will begin to power down, and after about 30 seconds, the power will automatically disconnect, causing the power-on indicator to go off.

If the system displays a question mark (?) in response to the DOWN command, you do not have the correct diskette inserted. Insert the a bootable n/STAR or Diangostic Diskette and try again.

3.6 THE IMPORTANCE OF BACKUP

Perhaps the most crucial part of working with a computer is learning to make copies of all your programs and data. Both diskettes and hard disks are vulnerable to accidental damage. If you copy your programs and data onto backup tapes and diskettes, you will be able to recover your information from those backup versions.



Systematic backup provides invaluable protection against information lost due to such things as operator error, equipment malfunction, and line transients. You will protect yourself against loss by storing information off-line.

3.6.1 Make Copies of System Diskettes

It is important to make copies of all system diskettes including the Distribution Diskette.

If you only have one copy of a system diskette and something happens to it, you will have to obtain another copy. To spare yourself this expense and inconvenience, copy the diskette before you use it for any other purpose.

See Section 3.7 for a description of copying a diskette. Use the procedure in Section 3.7.2 to make backup copies of the n/STAR Distribution Diskette and the Diagnostic Distribution Diskette.

3.6.2 Backup Your Data

When data is stored on diskettes or the hard disk, the risk is different. Here, you face the loss of the time and effort you have invested in generating the data. For example, if you have been working for a week on a report, and the disk containing your only version is accidentally erased, you will have to start again from the beginning.

The Supermicro offers you two methods of backing up your data. You may make backups on a diskette or on the tape unit. See Section 6.5 for a description of diskette operation and Chapter 5 for a description of the tape utility.

Experience suggests that a two-tier system of data backup provides the best insurance against data loss. For example, the first day you backup, label the tape or diskette version "A". The next day backup using a second tape or diskette labeled version "B". The third day backup onto the version "A" tape or diskette. Continue on in this manner alternating between the two backup media.

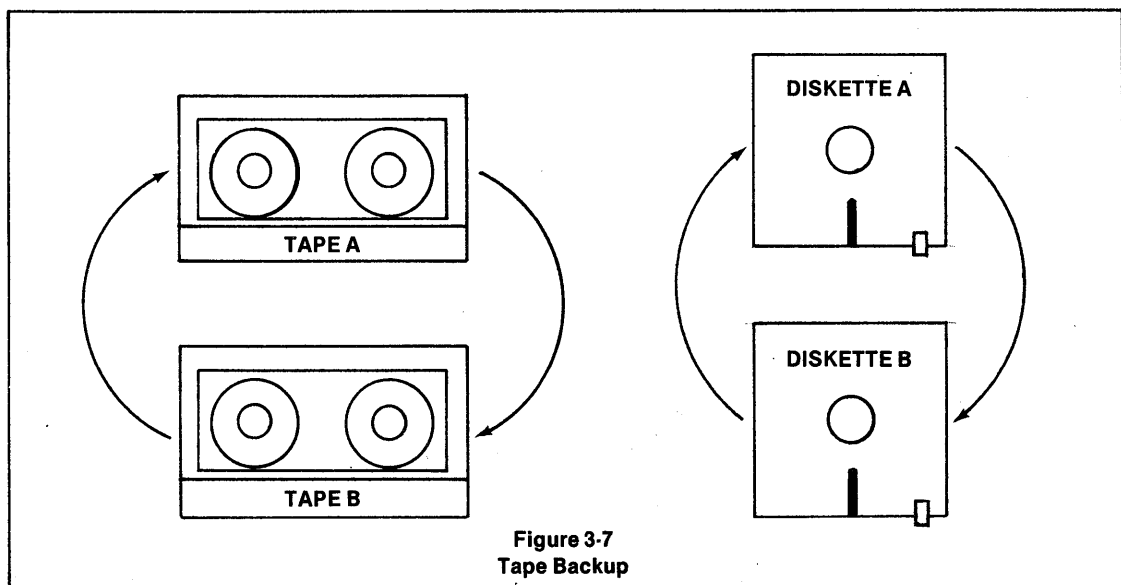



There is a major advantage to this method. At any given time, you have two diskettes or tapes containing some version of the same material. If only one version exists, you run a risk of it being lost since it must be present in the computer when you copy over it. If a power transient or program failure occurs while you are copying, then both versions may be destroyed. If a second copy exists, you can use it to recover your data.

Whatever method you prefer, develop and use a systematic backup procedure. Protect your financial investment in your programs and the effort and energy your data represent by taking the time to copy the information on the hard disk.

3.7 MAKING COPIES OF DISKETTES

You may make copies of diskettes when the Supermicro is configured for multi-user or diagnostic mode. When you copy a diskette, make sure that the write-enable tab is *not* over the write-enable notch (Figure 3-2). This tab allows a diskette drive to write on the diskette. When copying a diskette, the diskette drive should be able to read from the diskette but not write to it.

This manual refers to the diskette to be copied as the "source" diskette and the diskette receiving files as the "target" diskette.

3.7.1 Copying Diskettes in Multi-User Mode

To make a copy of a diskette in multi-user mode, follow the procedure described below. Read Section 6.5 for a description of diskette access under n/STAR.

Before you copy the diskette:

1. Make sure that PIP.COM is accessible from your logged-on user drive. Either have PIP.COM located in the logged-on user drive, or if PIP.COM is in the volume USERSYS, set the \$SYS flag. (See Section 6.2.6 for a description of directory search default.)
2. Format a diskette to use as the target diskette. (See Section 4.2 for a description of formatting diskettes.)
3. Establish an empty volume on your User Profile. This volume will hold the files on the diskette during the copying process.

Follow the sequence described below to copy the diskette:

1. Go into multi-user mode operating the system from a terminal attached to one of the application processors. (See Section 3.3.)
2. Insert the source diskette, and press CTRL-C. The screen will display

A>



3. Copy the contents of the diskette to the empty user drive. In this description, user drive P is the diskette drive and user drive A is the empty user drive.

Enter

```
PIP A:=P:*. *[ROV]
```

and press RETURN.

4. When you receive the user drive prompt, remove the source diskette.
5. Insert the target diskette. Press CTRL-C.
6. Copy the files from the hard disk user drive to the target diskette. To do this enter

```
PIP P:=A:*. *[ROV]
```

and press RETURN.

7. Erase all the files that were placed in user drive A. Type

```
ERA A:*. *
```

and press RETURN. The screen will display

```
ERASE (Y/N)?
```

Enter Y, and press RETURN.

8. When the prompt returns, the copying procedure is finished. Remove the diskette, and label it.

3.7.2 Copying Diskettes in Diagnostic Mode

To make copies of diskettes in Diagnostic Mode, you could use the PIP command and a procedure similar to the one described in Section 3.7.1. However, Molecular provides a simpler method to make a copy of everything on a diskette (data, programs, boot tracks), that creates an exact "image" of the diskette on a blank diskette. This method is especially useful to copy diskettes having files residing under several CP/M User Numbers. To make such diskette copies, use the IMAGE utility provided on the Diagnostic Diskette.

CAUTION

Make sure the write-enable tab is not over the write-enable notch on the Distribution Diskette. The write-enable tab allows the diskette drive to write on the diskette. By removing the write-enable tab, you are preventing the contents of the diskette from being altered or impaired.



1. Bring up the system in Diagnostic Mode, using a bootable Diagnostic Diskette. (See Section 2.3.2.)
2. Format a diskette to use as the target diskette. (See Section 4.2.)
3. Type

IMAGE

and press RETURN. The screen displays

```
*****
```

```
FLOPPY IMAGE COPYING UTILITY 02/10/83
```

```
COPYING OPTIONS TAKE THE FOLLOWING FORMAT:
```

```
FILENAME(VALID CP/M) SIDE(S/D) DENSITY(S/D) FLOPPY READ/WRITE(R/W)
```

```
EXAMPLE, SINGLE DENSITY FLOPPY READ: "FILE1 S S R" <CR>
```

```
EXAMPLE, DOUBLE DENSITY FLOPPY WRITE: "FILE1 S D W" <CR>
```

```
PLEASE INSERT FLOPPY AND ENTER OPTIONS: []
```

4. Remove the Diagnostic Diskette and insert the source diskette. (Note that the source diskette may be the Diagnostic Diskette, in which case you would leave it in the diskette drive for the following step.)
5. Type

filename S S R (do not use an extension)

and press RETURN. You may use any unused CP/M filename; however, do not supply an extension. IMAGE supplies its own extension (.IMG). This file is used as temporary storage during the copying procedure, and automatically defaults to the logical B drive unless you specify another drive by using the prefix n:. The screen displays

```
TRACK nn
```

```
PRESS CTRL-C TO EXIT OR ANY OTHER KEY TO CONTINUE
```

The track number increments as the information is copied.



6. Press RETURN. The program restarts and the screen displayed in Step 3 again appears.
7. Remove the source diskette and insert a formatted target diskette into the diskette drive.
8. Type

filename S S W

and press RETURN. The filename used here must exactly match the filename used in Step 5. The screen displays

TRACK nn

PRESS CTRL-C TO EXIT OR ANY OTHER KEY TO CONTINUE

The track number increments as the program copies the information.

9. To make additional copies of the source diskette, repeat steps 7 and 8. When you are finished making copies, remove the target diskette, insert the Diagnostic Diskette, and press

CTRL-C

to exit the program.

10. If you do not anticipate a need for additional copies of the source diskette, you should erase the image file created by IMAGE. To do this, type

n:

and press RETURN.

11. Type

ERA filename.IMG

and press RETURN to erase the image file.

12. Type

A:

and press RETURN to return to the operating system volume.

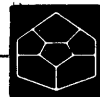

Example

Since this disk copying procedure involves several steps, let's look at an example. In this case, we will make a back-up copy of the n/STAR Distribution Diskette. This is a good example, because it has files residing under several CP/M User Numbers, making it cumbersome to copy using the PIP command.

The numbers of the following steps correspond to the numbers of the actual procedure just described.

1. Connect a terminal to the terminal port of the File Processor (connector in upper right corner of rear panel). Insert a bootable Diagnostic Diskette into the diskette drive. Turn on the power (or press BREAK if the power is already on).
2. Format a diskette using the DKM program described in Section 4.2.

NOTE

Many computer users find it convenient to purchase diskettes that are already formatted. If you use preformatted diskettes, you may skip Step 2.

3. Type

IMAGE

and press RETURN.

4. Remove the Diagnostic Diskette and insert the n/STAR Distribution Diskette (your source diskette).

5. Type

NSTARCPY S S R

and press RETURN. This tells the IMAGE utility to read the contents of the single-sided, single-density diskette that is currently in the diskette drive, and place the information read into a file called B:NSTARCPY.IMG on your logical B drive.

6. When the screen indicates that the procedure has finished, press RETURN. This returns you to the IMAGE menu.

7. Remove the n/STAR Distribution Diskette and insert your blank, formatted diskette (your target diskette).



8. Type

```
NSTARCPY S S W
```

and press RETURN. This tells the IMAGE utility to write the contents of the file B:NSTARCPY.IMG onto the diskette that is currently in the diskette drive.

9. If you want to make additional copies of the source diskette, simply repeat steps 7 and 8. When you are finished copying the source diskette, remove the target diskette and insert the Diagnostic Diskette.
10. Press

```
CTRL-C
```

(press the CTRL or CONTROL key, and while holding it down, press the C key, then release both keys.) This returns you to the operating system prompt (A>).

11. If you do not anticipate a need for additional copies of the source diskette, you should erase the image file created by IMAGE. To do this, type

```
B:
```

and press RETURN. This changes your logged drive from A to B. Note that the prompt is now B>.

12. Type

```
ERA NSTARCPY.IMG
```

and press RETURN.

13. Type

```
A:
```

and press RETURN to return to logical drive A (A>).

3.8 RESET PROCEDURES

The following reset procedures clear error conditions due to application program error, hardware malfunction, and system software error.

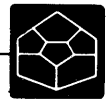

3.8.1 Resetting the Application Processor

You will need to reset the application processor if you have one of the following conditions:

- (1) A "hung" program caused by an error in the program. There is no response at the terminal.
- (2) A program runs continuously, and you are unable to interrupt its execution.

Reset the application processor by pressing CTRL-C. This causes the Command Control Processor (CCP) to be reloaded, and restores terminal response if the application program recognizes CTRL-C. This is generally effective for the first condition described above.

If pressing CTRL-C is effective, the terminal will return with the prompt (>) of the logged-on user drive. You may then begin to enter commands.

If pressing CTRL-C is not successful, press BREAK. This reloads n/STAR into the application processor. The screen will display the n/STAR initialization message.

Note

If the initial command for the application processor is blank, the contents of the user's application area (TPA under CP/M) will be still intact and may be saved for later analysis using the SAVE command. This feature is especially useful in a software development environment. The programmer has an opportunity to analyze the situations that cause a program under development to fail or "hang".

Refer to Section 6.7 for a description of operation without the security system. Refer to the CP/M literature for an explanation of the the SAVE command.

To reset an application processor other than the one to which you are physically connected, type

```
RESET unitnumber
```

where unitnumber is the unit (in decimal) to be reset. This command is especially useful for resetting the AP/86 Performance Accelerator, and for resetting application processors connected to spooling printers since user do not have direct control over these.

NOTE

1. Resetting the AP/86 takes several seconds.
 2. Access to the RESET program may be restricted by moving RESET.COM from the SYSTEM volume to another volume.
-



3.8.2 Resetting the File Processor

You will need to reset the file processor if all the terminals fail to respond to an n/STAR command, and the application processor reset procedure is not effective. This situation may be accompanied by the error message

MSM DOES NOT RESPOND

CAUTION

When you reset the file processor the files that are opened will not be closed properly. You will therefore lose the contents of those files.

Follow the sequence described below to reset the file processor:

1. Configure the system for diagnostic mode. (See Section 2.3.2.)
2. Press BREAK. The terminal will display

255 RESTART

3. Configure the system for multi-user mode. (See Section 2.3.2.)
4. Press BREAK. If the reset procedure is successful, the terminal will display the logged-off screen.

3.8.3 Resetting the System

Reset the system only if resetting the file processor does not bring up the logged-off screen.

When resetting the system, first try the reset sequence described below. This reset procedure will reset the system if one of the application processors has caused a "bus hang".

1. Configure the system for diagnostic mode. (See Section 2.3.2.)
2. Insert the Diagnostic Diskette.
3. Press BREAK. The screen will display

```
zzK CP/M Vn.n  
A>
```



4. Enter

DOWN

This will turn off the power to the system.

5. Remove the diskette.
6. Press the power-on button. The logged-off screen should appear on the screen.

If the procedure described above is not effective, either the copy of n/STAR on the hard disk is damaged or part of the hardware has failed. Reload a copy of the n/STAR operating system onto the hard disk drive. See Section 4.5 for a description of this procedure. If this does not display the usual logged-off screen, contact your hardware maintenance organization.



DIAGNOSTIC UTILITIES

4

The single-user configuration of the Supermicro is called diagnostic mode. Diagnostic mode operates under CP/M, and may be used for normal single-user operation or to run the diagnostic utilities.

During diagnostic mode, both the terminal and the printer are attached to the file processor. You have access to the diskette drive and the hard disk drive. CP/M is loaded into RAM from the diskette drive. See Section 2.3.2 for the cabling description of diagnostic mode and Section 3.4 for a description of going into diagnostic mode.

All the procedures described in this chapter must be performed with the system in diagnostic mode.

4.1 SYSTEM DRIVES UNDER DIAGNOSTIC MODE

Like multi-user mode, diagnostic mode divides each disk on the Supermicro into a number of logical drives. Each logical drive is from five to eight megabytes and is identified with a letter.

When the system is in diagnostic mode, the diskette is logical drive A. On disk unit 0 the first logical drive is B, the second logical drive is C, and so on. See Table 4-1 for the identifying letter for each logical drive.

Note: When the system is in diagnostic mode, the first logical drive on the hard disk is B, and when the system is in multi-user mode, the first logical drive on the hard disk is A.

The identifying letter for the drive is part of the operating prompt. For example, if you are using logical drive A, the system prompt on your terminal screen will be

```
A>
```

Each logical drive may be divided into 16 CP/M User Number partitions.

4.2 FORMATTING AND VERIFYING DISKETTES

The DKM program is used to format and verify diskettes. Before a diskette is used for the first time it must be formatted. The formatting procedure creates the file structures that must be present before a blank diskette can be used for storing data. Note: Formatting will also erase all the information previously written on a diskette.

The verifying procedure will check the formatting code on each sector, confirming that the code is present and correct. If the program finds an error in the formatting code, the screen will display an error message on the screen along with the location of the error. Note: The verifying procedure is non-destructive; the information on the diskette will not be altered by this process.

The DKM program on the Distribution Diskette formats and verifies diskettes. DKM is menu-driven and requires only single-character responses.

Before you start the diskette-formatting procedure:

1. Make sure the system is cabled for diagnostic mode. (See Section 2.3.2.)

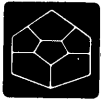

Table 4-1

Logical Drives On the Supermicro

	MODEL							
	SM8 10MB	SM8A 10MB	SM8 15MB	SM32 30MB	SM32 30MB	SM32 60MB	SM32 60MB	SM32 60MB
PARTITIONS SIZE (MB)	2 5	2 4.7	2 7.3	3 9.8	4 7.6	3 21	4 15	8 7.7
BLOCKSIZE	4/8/16K	4/8/16K	4/8/16K	8/16K	4/8/16K	16K	8K	4/8/16K
MAX # DRIVES	3	3	3	4	3	4	3	1
DISKETTE*	A	A	A	A	A	A	A	A
HARD DISK 0	B,C	B,C	B,C	B,C,D	B,C,D,E	B,C,D	B,C,D,E	B,C,D,E, F,G,J,K
HARD DISK 1	D,E	D,E	D,E	E,F,G	F,G,J,K	E,F,G	F,G,J,K	-
HARD DISK 2	F,G	F,G	F,G	J,K,L	L,M,N,O	J,K,L	L,M,N,O	-
HARD DISK 3	-	-	-	M,N,O	-	M,N,O	-	-

* Single sided/single density always used in diagnostic mode.

- Go into diagnostic mode operating the system from the terminal attached to the file processor. (See Section 3.4.)
- Place a write-enable tab on the diskette that will be formatted. The diskette to be verified does not require a write-enable tab.

The Supermicro diskette drives will accept diskettes that are:

single-sided, single-density
single-sided, double-density

Follow the sequence described below to format or verify a diskette on any of the Supermicro models.

Enter DKM, and press RETURN. The screen will display

S = SINGLE SIDED, D = DOUBLE SIDED

Enter S or D. Do not press RETURN. The screen will display

S = SINGLE DENSITY, D = DOUBLE DENSITY

Enter S or D. Do not press RETURN. The screen will then display

V = VERIFY, F = FORMAT



Table 4-1
Logical Drives On the Supermicro

MODEL								
DIRAC 30MB	DIRAC 30MB	SM64 DIRAC 68 60MB	SM64 DIRAC 68 60MB	SM64 136MB	SM64 136MB	SM64 136MB	SM64 136MB	
4	6	7	12	3	4	6	12	PARTITIONS
7.3	4.9	8.0	4.9	45.0	33.0	22.0	8.0	SIZE (MB)
8/16K	4/8/16K	8/16K	4/8/16K	16K	16K	16K	8/16K	BLOCKSIZE
3	2	1	1	4	3	2	1	MAX # DRIVES
A	A	A	A	A	A	A	A	DISKETTE*
B,C,D,E	B,C,D,E, F,G	B,C,D,E, F,G,J	B,C,D,E, F,G,J,K L,M,N,O	B,C,D	B,C,D,E	B,C,D,E, F,G	B,C,D,E, F,G,J,K L,M,N,O	HARD DISK 0
F,G,J,K	J,K,L,M, N,O	-	-	E,F,G	F,G,J,K	J,K,L,M N,O	-	HARD DISK 1
L,M,N,O	-	-	-	J,K,L	L,M,N,O	-	-	HARD DISK 2
-	-	-	-	M,N,O	-	-	-	HARD DISK 3

Enter V or F. Do not press RETURN.

If you press V, the the screen will display

INSERT DISKETTE, PRESS CTRL-S TO CONTINUE
PRESS CTRL-C TO ABORT.

Remove the Distribution Diskette. Insert the diskette to be verified, and press CTRL-S to continue with the verification process. The screen indicates the portion of the diskette currently being verified:

CYL *cc* - TRK *tt* - SEC *ss*

where

cc is the cylinder number.
tt is the track number.
ss is the sector number.

The screen will display an error message when the program finds a bad sector. If the diskette fails DKM, it can only be discarded. A bad sector error during the DKM process indicates there is a flaw on the diskette. Try running another diskette through the DKM formatting routine. If additional diskettes also generate error messages, there may be a hardware error in the diskette drive.



When the verification is complete, the screen will display

COMPLETE - PRESS CTRL-S TO RESTART.
PRESS CTRL-C IF DONE.

Press CTRL-S to return to the V = VERIFY, F = FORMAT prompt. You may now go through the process again.

If you are done with the DKM routine, remove the newly verified diskette. Re-insert the Distribution Diskette, and Press CTRL-C.

If you press F in response to the V = VERIFY, F = FORMAT prompt, the screen will display

WARNING: THIS OPERATION WILL DESTROY ANY
EXISTING DATA ON THE DISKETTE.

INSERT DISKETTE. PRESS CTRL-S TO CONTINUE.
PRESS CTRL-C TO ABORT.

Remove the Distribution Diskette. Insert the diskette to be formatted, and press CTRL-S to continue with the formatting procedure. The screen will display

CYL *cc* - TRK *tt*

as the formatting proceeds. *cc* is the cylinder number, and *tt* is the track number that is currently being formatted. After the diskette is formatted, the program automatically goes through the diskette again and verifies that the formatting code is present and correct. When the verifying portion of the process begins, the sector number will appear on the screen along with the cylinder number and the track number.

When the process is complete, the screen will display

COMPLETE - PRESS CTRL-S TO RESTART. PRESS
CTRL-C IF DONE.

Press CTRL-S to return to the V = VERIFY, F = FORMAT prompt.

If you are done with the DKM routine, remove the newly formatted diskette. Re-insert the bootable system diskette, and Press CTRL-C.

4.3 **FORMATTING, VERIFYING, AND CONFIGURING THE HARD DISK**

The SYSINT program formats, verifies, and configures the hard disk unit. Each Supermicro is delivered with a properly formatted and tested hard disk. The SYSINT program is only required when the hard disk has been replaced or if you want to completely erase all data on the disk.

Before a hard disk is used for the first time it must be formatted. The formatting procedure creates the file structures that must be present before the disk can be used for storing data. Note: The formatting procedure will erase all information on the hard disk.



The verifying procedure on the hard disk checks the formatting code on each sector, confirming that the code is present and correct. If the program finds an error in the formatting code, the screen will display a disk error code. Note: The verifying procedure is non-destructive; the information on the disk will not be altered in this read process.

The disk configuration procedure allows you to define the size of the file blocks and maximum number of directory entries for each logical drive. The hard disk drive must be configured after it has been formatted. You would use this procedure after you format a disk or after you receive a pre-formatted disk from the factory. If you wish to re-configure the disk after data has been written on the disk, you must: transfer the information from the disk onto tape, reformat the disk, define the configuration, and then transfer the information on tape back to the disk.

Before you start the hard-disk formatting procedure:

1. Make sure the system is cabled for diagnostic mode. (See Section 2.3.2.)
2. Go into diagnostic mode operating the system from the terminal attached to the file processor. (See Section 3.4.)

The SYSINT program formats, configures, and verifies the hard disk. Type SYSINT after the A>, and press RETURN. The screen will display the

DRIVE 0, 1, 2, 3

Enter the number of the hard disk drive. Do not press RETURN. (See Table 4-1 for the number identifying each hard disk unit.) The screen will display

F = FORMAT/VERIFY, V = VERIFY ONLY,
D = DISK OPTION

Enter F, V, or D. Do not press RETURN.

Enter F if the drive has never been formatted, or if you want to change directory or block allocation sizes to new values. This entry will format the hard disk and verify the formatting.

Enter V to verify the hard disk formatting.

Enter D if the drive has been formatted but not configured. This entry modifies the maximum size of the logical drive directories, and the block sizes.

4.3.1 Formatting the Hard Disk

Supermicro 32 and Supermicro 64

The procedure described below describes formatting the hard disk on the Supermicro 32 and the Supermicro 64.



After you enter F in response to the prompt described above, the Supermicro 32 and Supermicro 64 will display

WARNING: THIS PROCEDURE WILL DESTROY ANY EXISTING DATA ON THE DISK. BE SURE ALL FILES ARE PROPERLY ARCHIVED PRIOR TO RUNNING THIS UTILITY.

THE SWITCHES ON THE PRIAM BASIC CONTROLLER SHOULD BE SET AS FOLLOWS:

	<i>nn/nn/nnnn</i>	<i>nn/nnn/nnnn</i>
UPPER:	1, 6-8 ON	1, 6-8 ON
LOWER:	2, 5 ON	3, 4 ON
ALL OTHERS:	OFF	

OK (Y OR N) ?

These switches are set before they leave the factory and you may ignore this screen display. Enter Y (do not press RETURN). If you enter N, the program will return you to the operating system prompt. After you enter Y, the screen will display

C = CONTINUOUS, S = SINGLE PASS

After the disk is formatted, the program verifies the formatting code. Press S to verify the format in a single pass. Press C to continue the verification. Press CTRL-S to interrupt the verification. After your response to the above statement, the screen displays

Redirect bad sector ? Y/N ()

Type

Y

Do not press RETURN. Normally, you will want to redirect a bad sector so that an "extra" sector on the disk is used in its place. The hard disk drives in your Supermicro system have extra sectors especially for this purpose. If a bad sector is detected, the disk drive remembers where the sector is located, and when that sector is needed, uses one of the extra sectors in its place. This feature, once established, is totally automatic; the programmer and user need not be concerned with redirected sectors.

The program begins formatting the hard disk. During this process the screen displays

DISKOS nnnn

Formatting ...



When the formatting is complete, the program will begin initialization. The screen will display

```
NUMBER OF CYLINDERS:      nn
TRACKS PER CYLINDER:     nn
SECTORS PER TRACK:       nn
BYTES PER SECTOR:        nn
```

```
INITIALIZING ...
```

When the initializing is complete, the program will verify the hard disk. The screen will display

```
nnn Cylinder Verified
nnn Bad sectors redirected
```

The number of the cylinder being verified appears on the screen, as well as the number of bad sectors found and redirected. If there is a disk error, the screen displays an error message. See Table 7-5 for the Disk error Summary Codes for the Supermicro 32 and the Supermicro 64. When verification is complete, the screen displays

```
Complete
```

```
Hit RETURN to continue []
```

Press the RETURN key. The program then goes to the Disk Configuration routine described in Section 4.3.3.

Supermicro 8

After you enter F in response to the prompt described in section 4.3, the screen will display

```
WARNING: THIS PROCEDURE WILL DESTROY ANY EXISTING DATA ON
THE DISK. BE SURE ALL FILES ARE PROPERLY ARCHIVED PRIOR TO
RUNNING THIS UTILITY.
```

```
OK (Y OR N) ?
```

If you press N, the system will go to the operating system prompt. If you press Y, the screen will display

```
REDIRECT BAD SECTORS (Y/N)?
```

Press Y to redirect bad sectors to another portion of the disk. If you press N, the bad sectors must be redirected in another formatting procedure. The screen will display

```
C = CONTINUOUS, S = SINGLE PASS
```



After the disk is formatted, the program will verify the formatting code. Press S to verify the format in a single pass. Press C to continue the verification until you interrupt the process. The screen will then display

nn CYLINDER FORMATTED

showing the cylinder number as it is being formatted. When the initialization starts, the screen will display

nn CYLINDER INITIALIZED

showing the cylinder number as it is being initialized. When the verification starts, the screen will display

nn CYLINDER VERIFIED

If there is a disk error, the screen will display an error message. See Table 7-8 for the Disk Error Summary Codes. If you specified redirection earlier in this procedure, the portion of the disk with the error will be redirected to another place on the disk.

The screen will display

PRESS RETURN TO CONTINUE

The program will then go into the Disk Configuration routine. See Section 4.3.3.

4.3.2 Verifying the Hard Disk

Supermicro 32 and Supermicro 64

After you enter V, the screen will display

C = CONTINUOUS, S = SINGLE PASS

Enter C or S. If you enter S, the screen will display

Redirect bad sector ? Y/N ()

Type

Y

Do not press RETURN. Normally, you will want to redirect a bad sector so that an "extra" sector on the disk is used in its place. The hard disk drives in your Supermicro system have extra sectors especially for this purpose. If a bad sector is detected, the disk drive remembers where the sector is located, and when that sector is needed, uses one of the extra sectors in its place. This feature, once established, is totally automatic; the programmer and user need not be concerned with redirected sectors.



The screen displays

```
DISKOS nn  
  
NUMBER OF CYLINDERS:      nn  
TRACKS PER CYLINDER:     nn  
SECTORS PER TRACK:       nn  
BYTES PER SECTOR:        nn
```

as the hard disk is being verified. When the verification is complete, the screen will display

```
nnn Cylinder Verified  
  
nnn Bad sectors redirected  
  
COMPLETE  
A>
```

If there is a disk error, the screen will display an error message. See Table 7-5 for the Disk error Summary Codes for the Supermicro 32 and the Supermicro 64.

Supermicro 8

After you enter V on the Supermicro 8, the screen will display

```
REDIRECT BAD SECTORS (Y/N)?
```

If you press Y, the screen will display

```
C = CONTINUOUS, S = SINGLE PASS
```

Press S to verify the format in a single pass. Press C to continue to verify the format until you interrupt the process. The screen will display

```
nnn Cylinder Verified  
  
nnn Bad sectors redirected
```

as each cylinder is being verified.

If there is a disk error, the screen will display an error message. See Table 7-6 for the Disk Error Summary Codes. If you specified redirection earlier in this procedure, the portion of the disk with the error will be redirected to another place on the disk.

When the entire disk has been verified, the screen displays

```
Complete  
A>
```



4.3.3 Configuring the Disk Table

After you enter D in response to the SYSINT prompt described in Section 4.3, the screen will display

```

****WARNING****
TO CHANGE THE DIRECTORY/BLOCKSIZE OPTION ON YOUR DISK,
YOU MUST ARCHIVE ALL YOUR DATA AND REFORMAT THE DISK

CONTINUE ? Y/N

```

Press Y or N. Do not press RETURN. Enter N to cancel. If you enter Y, the screen will display

SYSTEM DISK INITIALIZATION ROUTINE

```

                                Supermicro*xx yyMB
OPTIONS IS:                      0          1          2          3          4
    DIRECTORY:                    nnnn      nnnn      nnnn      nnnn      nnnn
    BLOCKSIZE:                     nnK       nnK       nnK       nnK       nnK
    SIZE(MB):                       n.n       n.n       n.n       n.n       n.n
    PARTITION:                      nn        nn        nn        nn        nn
    MAX DRIVE:                      n         n         n         n         n

SELECT CONFIGURATION OPTION (0-4)  ([])

```

Table 4-2 shows the directory and blocksize options for each Supermicro model.

Enter 0, 1, 2, 3, or 4. If the option selected for hard disk drives 1, 2, or 3 is different from hard disk drive 0, a warning message displays. In this case you must enter the option that corresponds to hard disk 0. The blocksize options are shown in Table 4-2.

The screen displays the disk configuration information for each CP/M User Number:

```

ALL PARTITIONS SHOWN ARE FOR ONE DRIVE ONLY
CONFIGURATION IS:

```

PARTI	TYPE	DIRECTORYS	BYTES/BLOCK	CAPACITY
0-5	<i>nn</i>	<i>nn</i>	<i>nn</i>	<i>nn</i>
6	<i>nn</i>	<i>nn</i>	<i>nn</i>	<i>nn</i>
7	<i>nn</i>	<i>nn</i>	<i>nn</i>	<i>nn</i>
14	<i>nn</i>	<i>nn</i>	<i>nn</i>	<i>nn</i>
15	<i>nn</i>	<i>nn</i>	<i>nn</i>	<i>nn</i>

CONFIGURATION CORRECT ? Y/N

where the type, directory size, bytes per block size and capacity are displayed for each partition.

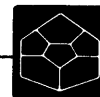

TABLE 4-2
Directory and Blocksize Options Table

CONFIGURATION	OPTION				
	0	1	2	3	4
Supermicro 8 (10MB)					
Directory	320	640	1280	-	-
Blocksize	16K	8K	4K	-	-
Size (MB)	5.0	5.0	5.0	-	-
Partitions	2	2	2	-	-
Max # Drives	3	3	3	-	-
Supermicro 8A (10MB)					
Directory	320	640	1280	-	-
Blocksize	16K	8K	4K	-	-
Size (MB)	4.7	4.7	4.7	-	-
Partitions	2	2	2	-	-
Max # Drives	3	3	3	-	-
Supermicro 8 (15MB)					
Directory	512	1024	2048	-	-
Blocksize	16K	8K	4K	-	-
Size (MB)	7.3	7.3	7.3	-	-
Partitions	2	2	2	-	-
Max # Drives	3	3	3	-	-
DIRAC (30MB)					
Directory	320	640	1280	1024	512
Blocksize	16K	8K	4K	8K	16K
Size (MB)	4.9	4.9	4.9	7.3	7.3
Partitions	6	6	6	4	4
Max # Drives	2	2	2	3	3
Supermicro 32 (30MB)					
Directory	512	1024	1920	1024	1280
Blocksize	16K	8K	4K	16K	8K
Size (MB)	7.6	7.6	7.6	9.8	9.8
Partitions	4	4	4	3	3
Max # Drives	3	3	3	4	4
Supermicro 32 (60MB)					
Directory	512	1024	2048	2048	1536
Blocksize	16K	8K	4K	8K	16K
Size (MB)	7.7	7.7	7.7	15	21
Partitions	8	8	8	4	3
Max # Drives	1	1	1	3	4
Supermicro 64 (60MB) and DIRAC 68-32 (60MB)					
Directory	320	640	1280	1024	512
Blocksize	16K	8K	4K	8K	16K
Size (MB)	4.9	4.9	4.9	8.0	8.0
Partitions	12	12	12	7	7
Max # Drives	1	1	1	1	1
Supermicro 64 (136MB)					
Directory	512	768	1536	2560	3072
Blocksize	16K	8K	16K	16K	16K
Size (MB)	8.0	8.0	22.0	33.0	45.0
Partitions	12	12	6	4	3
Max # Drives	1	1	2	3	4

All CP/M User Number partitions correspond to a single-drive system. Partitions on drives 1 through 3 are consecutively lettered with no gaps for diskette drives. The partition is shown as a numeric value rather than an ASCII letter to allow for future expansion to systems with more than 26 partitions.

Enter Y or N. If you enter N, the screen will display the options choice again. If you enter Y, the screen will display

FUNCTION COMPLETE
PRESS BREAK KEY TO REBOOT

Press the BREAK key. The program then goes go back to operating system prompt.

After the disk configuration is complete, you must establish the boot tracks for the n/STAR Operating System and load n/STAR onto the hard disk. See Section 4.5 for a description of this procedure.



4.4 UPGRADING AN OLD RELEASE OF n/STAR

As n/STAR is revised and improved, Molecular Computer makes available a set of Upgrade Diskettes to allow you to convert your current operating system to the latest version. As with the diskettes shipped with new systems, these diskettes are not bootable. You must make the diskettes bootable by copying onto them CP/M from an earlier n/STAR release.

The new version of n/STAR requires a 56K transient program area (TPA) derived from a 56K version of CP/M. If you are already running a 56K version of n/STAR (Versions 2.44 and higher), follow the procedure in Section 4.4.1 to make your new diskettes bootable. However, if you are running a version of n/STAR with a different size TPA (usually 60K in Versions 2.42 and lower), follow the procedure in Section 4.4.2. By following the appropriate procedure, you will create a bootable n/STAR system diskette containing the latest version of n/STAR. You will then load it onto the hard disk by following the procedure in Section 4.5.

IMPORTANT NOTE

If you are upgrading an older version of n/STAR to Revision 2.49 or higher and intend to use the new version on a Supermicro X series computer, you **must** follow the procedures in Section 4.4.2, regardless of the TPA size of your current operating system. This procedure will ensure that a new version of DBIOS is implemented.

4.4.1 Upgrading from a 56K Version of n/STAR

If your existing version of n/STAR uses a 56K TPA, you can create a bootable n/STAR system diskette simply by running SYSGEN to copy CP/M onto the new n/STAR Distribution Diskette.

1. Configure your system for Diagnostic Mode as described in Section 3.4.
2. Insert your existing bootable n/STAR Diskette into the diskette drive.
3. Press BREAK to boot the system.
4. When the screen displays the system prompt (A>), type SYSGEN and press RETURN. The screen displays

```
SYSGEN VER n.n  
SOURCE DRIVE NAME (OR RETURN TO SKIP)
```

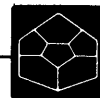

5. Type

A

Do not press RETURN. The screen displays

SOURCE ON A, THEN TYPE RETURN

6. Press RETURN. The screen displays

FUNCTION COMPLETE
DESTINATION DRIVE NAME (OR RETURN TO REBOOT)

7. Remove the bootable n/STAR Diskette from the diskette drive and insert the new n/STAR Distribution Diskette.

8. Type

A

Do not press RETURN. The screen displays

DESTINATION ON A, THEN TYPE RETURN

9. Press RETURN. The screen displays

FUNCTION COMPLETE
DESTINATION DRIVE NAME (OR RETURN TO REBOOT)

10. Press BREAK to boot the system from your new n/STAR bootable system diskette. Do not press RETURN. The screen displays

FP RESTART

then

Supermicro*xx yyMB Diagnostic Diskette

zzK CP/M Vn.nnp
A>

Your Supermicro is now running under the new version of n/STAR in Diagnostic Mode. To install your new version of n/STAR onto the hard disk, follow the instructions in Section 4.5.2.



4.4.2 Upgrading from a Non-56K Version of n/STAR

If you are running a version of n/STAR with a 60K or other size TPA, you must reconfigure your existing operating system to 56K. Also, if you are installing a new Supermicro X system and want to upgrade your old version of n/STAR to run on the new system, you must use this procedure. To do this, you need a bootable system diskette with at least 9K bytes of available disk space and the files:

MOVCPM.COM	(DRI program to place CP/M in memory)
DDT.COM	(DRI diagnostic program)
SYSGEN.COM	(DRI program to write CP/M on a disk)
DBOOT.HEX	(Initialization patch for CP/M)
DBIOS.HEX	(Molecular disk drivers for CP/M)

1. Using the bootable system diskette, go into Diagnostic Mode. (See Section 3.4.) Enter the command lines shown below, and press RETURN after each line.

```
MOVCPM 56 *
SAVE 34 CPM56.COM
DDT CPM56.COM
```

2. The system is now running under DDT. Remove the bootable system diskette and insert the new n/STAR Distribution Diskette. Enter the following commands to patch CP/M. Press RETURN after each line.

```
ISYSGEN.COM
R0
IDBOOT.HEX
R900
IDBIOS.HEX
R4580
F5D,5D,20      (clear the default FCB)
G100           (execute SYSGEN)
```

3. The screen displays

```
SYSGEN VER n.n
SOURCE DRIVE NAME (OR RETURN TO SKIP)
```

4. Press RETURN to skip the read cycle. The screen displays

```
DESTINATION DRIVE NAME (OR RETURN TO REBOOT)
```

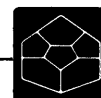

5. Type

A

Do not press RETURN. The screen displays

DESTINATION ON A, THEN TYPE RETURN

6. Press RETURN. The screen displays

FUNCTION COMPLETE
DESTINATION DRIVE NAME (OR RETURN TO REBOOT)

7. If you want to make additional copies of this n/STAR bootable system diskette, remove the target diskette and insert a non-bootable n/STAR Distribution Diskette into the diskette drive. Then repeat steps 5 and 6.

8. When you are finished making bootable system diskettes, press

BREAK

to boot the system from the bootable diskette now in the diskette drive. Do not press RETURN. The screen displays

FP RESTART

then

Supermicro*xx yyMB Diagnostic Diskette

zzK CP/M Vn.n

A>

Your Supermicro is now running under the new version of n/STAR in Diagnostic Mode. Now, follow the procedures in Section 4.5.2 to install your new version of n/STAR onto the hard disk.

4.5 LOADING N/STAR ONTO THE HARD DISK

Before the Supermicro can function, n/STAR must be installed on the hard disk. Each Supermicro system shipped by Molecular has the latest version of n/STAR already installed on the hard disk. However, there are times when you will need to install n/STAR again. You will need to install n/STAR if:



- You are replacing your existing version with a new version of n/STAR.
- The contents of the hard disk are destroyed.
- The hard disk drive is replaced.

You may install n/STAR on your hard disk in one of three ways, each producing a different result.

Section 4.5.1 describes how to install the operating system boot tracks only. You may want to do this when troubleshooting the system. Only the boot tracks themselves are loaded -- none of the n/STAR utilities are placed on the hard disk, and all files on the hard disk are unchanged.

Section 4.5.2 explains how to install the operating system and all of the n/STAR utilities in one operation. This is the method you will usually use to upgrade your system to a new version of n/STAR, since you will want both the new operating system and the new and enhanced utilities installed. This procedure also leaves all existing files on the hard disk (with the exception of the new n/STAR utilities) unchanged.

Finally, Section 4.5.3 describes how to format the hard disk, install n/STAR and all of its utilities, and establish users DEMO and MAINTUSR all in one operation. You would use this method only to reestablish the operating system after a fatal hard disk failure in which all data and programs were lost. This procedure results in a formatted hard disk with a new version of the operating system; all existing data files are destroyed.

NOTE

Before installing n/STAR onto the hard disk, you must make your new n/STAR Distribution Diskette bootable, as explained in Section 4.4.

4.5.1 Installing the n/STAR Operating System Only

The following procedure explains how to install just the boot tracks of n/STAR. You may need to do this during some troubleshooting procedures, but ordinarily you will instead use the procedure in Section 4.5.2.

1. Using your new, bootable n/STAR system diskette, bring up the Supermicro in Diagnostic Mode. (See Section 3.4)
2. Type

GENSTAR

and press RETURN. The screen displays

022583



NEW VERSION IS n/STAR n.nnp
OLD VERSION IS n/STAR n.nnp

CONTINUE ? Y/N ([])

Note that the "old version" prompt appears only if there is an old version of the operating system already on the hard disk. If you have just formatted the hard disk drive, the operating system was erased; consequently, the "old version" line does not appear.

3. Type

Y

Do not press RETURN. The screen displays

FUNCTION COMPLETE

4. Remove the n/STAR Diskette from the diskette drive and store it in a safe place.

The boot tracks of the n/STAR operating system are now installed on your hard disk.

5. Press BREAK to bring up the system in Multi-User Mode under the newly installed operating system.

4.5.2 Installing n/STAR and the n/STAR Utilities

Use the following procedure to upgrade your system to a new version of n/STAR, or at any time you want to copy both the operating system and its utilities from diskette to the hard disk.

1. Using your new, bootable n/STAR system diskette, bring up the Supermicro in Diagnostic Mode. (See Section 3.4)
2. Type

STAT A:DSK:

and press RETURN. The screen displays the current disk configuration option. Make a note of this option.



3. Type

SUBMIT GENSTAR

and press RETURN. The screen displays

*** Install new n/STAR ***

When SYSINT runs, DO NOT format or verify your disk.
Use the "D" option to reselect your disk configuration.
A>SYSINT

The installation procedure requires you to run SYSINT to set up the disk directories for directory hashing. This procedure is non-destructive to your existing data AS LONG AS YOU SELECT THE DISK CONFIGURATION CURRENTLY IN USE. (This is the reason for performing Step 2.) The screen displays

SYSTEM DISK INITIALIZATION ROUTINE

DRIVE 0, 1, 2, 3 ([])

4. Enter the number of the hard disk drive to configure. Do not press RETURN. (Refer to Table 4-1 for the number identifying each hard disk unit.) The screen displays

F = Format/Verify, V = Verify Only, D = Disk Option ([])

5. Enter

D

do not press RETURN. Be certain that you do not select format or verify at this time. The screen displays

*****WARNING*****

TO CHANGE THE DIRECTORY/BLOCKSIZE OPTION ON YOUR DISK,
YOU MUST ARCHIVE ALL YOUR DATA AND REFORMAT THE DISK.

CONTINUE ? Y/N ([])



6. Since you will select the same option as you now are using, you may disregard this message. You will not destroy any data on your disk if you correctly follow this procedure. Type

Y

Do not press RETURN. The screen displays a table of possible disk configurations and details about each. (For an illustration of this table, see Section 4.3.3.) At the bottom of the table, the screen displays

```
SELECT CONFIGURATION OPTION (0-4) ([])
```

7. Enter the number of the configuration your system is now using (as displayed in Step 2). BE SURE TO ENTER THE CORRECT NUMBER, OR EXISTING DATA MAY BE DESTROYED. The screen displays a table of information pertaining to the configuration you select. At the bottom of this table, the screen displays

```
CONFIGURATION CORRECT ? Y/N ([])
```

8. If you are certain that you entered the correct configuration, type

Y

do not press RETURN. (If you entered the wrong configuration, type N to make another selection.) The screen displays

```
FUNCTION COMPLETE  
Hit BREAK key to exit program
```

9. Press the BREAK key. The screen displays

```
A>GENSTAR
```

```
NEW VERSION IS n/STAR n.nnp  
OLD VERSION IS n/STAR n.nnp
```

```
CONTINUE ? Y/N ([])
```

Note that the "old version" prompt appears only if there is an old version of the operating system already on the hard disk. If you have just formatted the hard disk drive, the operating system was erased; consequently, the "old version" line does not appear.



10. Type

Y

Do not press RETURN. The screen displays

```
FUNCTION COMPLETE
A>PIP B:=A:*. *[G1VR]
COPYING -
filename 1
filename 2
filename 3
.
.
.
filename n
A>
```

11. When all of the files are copied from the n/STAR Diskette onto the hard disk, remove the n/STAR Diskette from the diskette drive, then press BREAK to bring up the system in Multi-User Mode under the newly installed version of n/STAR.

The new version of n/STAR and all of the new n/STAR utilities are now installed on your hard disk.

4.5.3 Installing n/STAR on an Empty Hard Disk

This procedure explains how to completely reinstall the operating system. You would normally use this procedure only after a fatal hard disk failure or after installing a new hard disk drive. To upgrade your operating system to a new version, use the procedure in Section 4.5.2.

CAUTION

The following procedure completely destroys all data, programs, and formatting on the hard disk. Before proceeding, be certain that you understand the implications of this procedure and that you have, if possible, backed up all programs and data on the hard disk.



1. Using your new, bootable n/STAR system diskette, bring up the Supermicro in Diagnostic Mode. (See Section 3.4.)

2. Type

```
SUBMIT INSTALL
```

and press RETURN. The screen displays

```
A>SYSINT
      SYSTEM DISK INITIALIZATION ROUTINE
      DRIVE 0, 1, 2, 3 ([])
```

3. Refer to Section 4.3 to format, verify and select disk options on each hard disk drive. When SYSINT is finished, the screen displays

```
FUNCTION COMPLETE
Hit BREAK key to continue
```

4. Press BREAK, and the screen displays

```
Supermicro*xx yyMB
nnK CP/M Vn.nnp
A>GENSTAR
NEW VERSION IS n/STAR n.nnp
CONTINUE ? Y/N ([])
```

5. Type

```
Y
```

Do not press RETURN. The screen displays

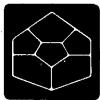

```
A>PIP B:=A:MESSAGE.SYS[VR]
A>PIP B:=A:*. *[G1VR]
COPYING -
filename 1
filename 2
filename 3
.
.
.
filename n
A>GENSYSF
A>
```

6. When all files are copied onto the hard disk, remove the n/STAR Diskette from the diskette drive and store it in a safe place.
7. Press BREAK to bring up the system in Multi-User Mode operating from the newly installed version of n/STAR.

Your Supermicro has now been completely reinitialized, and contains only the operating system, utilities, and two user IDs. You must log on as either DEMO or MAINTUSR and use the utility MAINT to establish users and volumes.

4.5.4 Installing CP/M Utilities onto the Hard Disk

Digital Research Incorporated (DRI) supplies several useful utilities on the CP/M Distribution Diskette. Since these utilities are property of DRI, Molecular cannot include them as part of n/STAR. However, you can copy any or all of the utilities onto your hard disk after installing your system.

The CP/M utilities are:

ASM.COM	DRI assembler
DDT.COM	DRI interactive debugger
DUMP.COM	DRI file display utility
DUMP.ASM	DRI file display source code
ED.COM	DRI editor
LOAD.COM	DRI object file editor
MOVCPM.COM	DRI CP/M relocation program
STAT.COM	DRI system status utility
SUBMIT.COM	DRI batch execution utility

To copy any or all of these utilities onto your hard disk (assuming you want them on the volume assigned to logical drive O, and assuming that the diskette drive is assigned to logical drive P), configure the system for Multi-User Mode, place the CP/M diskette into the diskette drive, and type

```
PIP O:=P:filename.ext[ROV]
```

where filename.ext is one of those listed above.



TAPE BACKUP

5

The Tape Backup System consists of a tape drive unit and a menu-driven file backup utility. The Tape Backup System backs up files from the hard disk to a tape cartridge. When restoration of the files is necessary, the contents of the tape may be copied to the disk. Files may be selected by logical disk drives, user numbers, ambiguous file identifiers, and specific tape names. The tape utility will also retension the tape and print a directory of all the files on the tape.

5.1 PURPOSE OF TAPE BACKUP

The Supermicro Tape Backup System provides safe, long-term protection for data stored on a hard disk. A regular, systematic schedule of disk backup to tape is invaluable insurance against the loss of programs and data that can result from operator error or system failure.

The magnetic tape cartridges used by the Tape Backup System are an advantageous storage medium because they have greater storage capacity and faster backup time than diskettes can provide.

5.2 OPERATION OF TAPE BACKUP UNIT

The Tape Backup utility runs under diagnostic mode. Like other utilities running in diagnostic mode, tape backup loads from the diskette drive and operates from the system terminal attached to the file processor.

The Supermicro 8 and the Supermicro 32 house the Tape Backup unit in the primary Supermicro cabinet. The Supermicro 64 houses the Tape Backup Unit in a second cabinet. See Section 2.3.2 for a description of cabling the Supermicro for diagnostic mode.

5.2.1 Handling Tape Cartridges

To avoid loss of data, take the following precautions when handling the tape cartridges:

1. Never touch the tape surface with your fingers.
2. Never allow liquids to get into a tape cartridge.
3. Keep tape cartridges away from magnets and magnetized objects.
4. Make sure the environment for the cartridge is within these limits:

Temperature	41° to 113°F (5° to 45° C)
Relative humidity	20% to 80% noncondensing

Before using a tape cartridge, allow it to reach equilibrium with the temperature and humidity of the environment in which it will be used. Expose the tape cartridge to the operating environment for a period equal to the interval the tape cartridge has been exposed to other conditions, up to a maximum of eight hours. For example, if the tape cartridge has been exposed to higher temperatures for four hours, allow it to spend four hours cooling off in the operating environment before you run the tape.



If you suspect that the cartridge has been exposed to either of the temperature extremes listed above, retension the cartridge before using it. Section 5.4.4 describes the retensioning procedure.

5.2.2 Inserting a Tape Cartridge

CAUTION

Be sure the Supermicro is turned on before you insert a tape cartridge in the drive slot. Likewise, do not turn the tape drive unit off until you have removed the tape cartridge.

To insert a tape cartridge, slide the cartridge into the tape-drive slot until you feel some resistance, then push it until it snaps into place. The tape drive unit automatically re-winds the tape to the starting position.

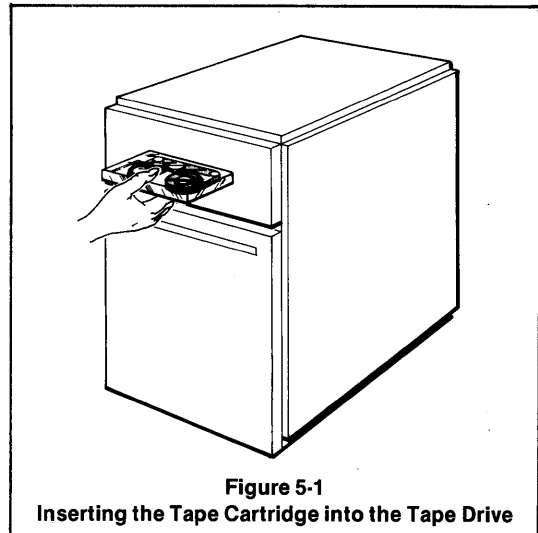

Figure 5-1
Inserting the Tape Cartridge into the Tape Drive

Never remove a cartridge from the tape drive unit while the tape is moving. This may destroy information stored on the cartridge. Wait until the function is complete and the tape has stopped moving. To remove the cartridge from the drive, grasp the protruding edge and pull the tape carefully out of the slot.

The write-protect switch on the cartridge protects the tape from write operations. Use a coin or screw driver to turn the switch on the tape cartridge so the arrow points to the SAFE position.

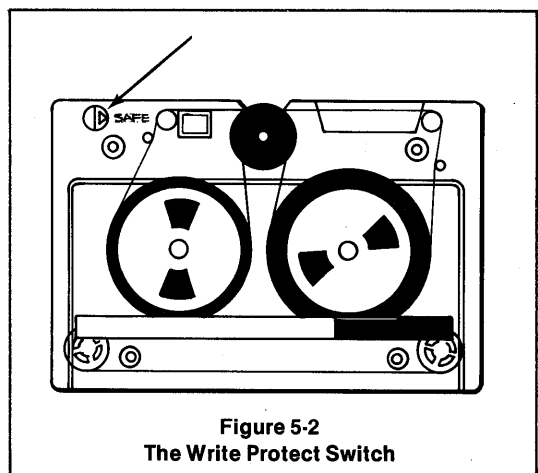
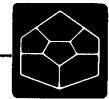

Figure 5-2
The Write Protect Switch



5.3 TAPE BACKUP TUTORIAL

This section describes how to use the Supermicro tape backup and recovery procedures.

The purpose of tape backup is to copy the contents of the hard disk onto magnetic tape cartridge(s) in case the information stored on disk is destroyed. If the contents of the hard disk is lost, files can be recovered from the tape.

The Tape Backup utility is menu-driven. By making selections in the Tape Backup Menu, you may backup files onto a tape cartridge, restore files to the hard disk, display or print the files on tape, or retension the tape.

To copy files from the hard disk to the tape cartridge, select **BACKUP DISK FILES TO TAPE (B)** in the Tape Backup Menu. This process allows you to place a complete image of the hard disk or a portion of the hard disk onto tape cartridges. You may select files by system drive letter, CP/M User Number, ambiguous filename and specific filename. A complete backup is unnecessary if some, but not all, of the files on the hard disk are updated. In this case, you will probably want to back up only the files that have been revised.

If the contents of the hard disk are destroyed, the files can be recovered back to the hard disk by selecting **RESTORE DISK FILES FROM TAPE (R)** in the Tape Backup Menu. This selection allows you to copy the files on the tape cartridge back to the hard disk. Like the backup procedure described above, you may select files by system drive letter, CP/M User Number, ambiguous filename, and specific filename. If you lose a single file or only a portion of the contents of the hard disk, this procedure allows you to recover a subset of the files on the tape.

If you wish to list the file contents of a tape cartridge, select **LIST TAPE DIRECTORY (D)** in the Tape Backup Menu. This selection allows you to display and print the files on the tape cartridge.

The magnetic tape wraps around the two spools inside the tape cartridge. The proper amount of tension is required for the tape head to read and write properly. Since the retensioning procedure restores the correct tension to the tape, it can often alleviate read/write errors. Select **RETENSION (T)** in the Tape Backup Menu to retension the tape. Retensioning is necessary when the tape is new, if it has not been used recently, or if it has been exposed to temperature extremes. The retensioning process rewinds the tape, runs the tape forward at a rate of 90 inches-per-second until it reaches the end of the tape, and then rewinds the tape again.

5.4 TAPE BACKUP PROGRAM

Follow the procedure described in Section 3.4 to load the diagnostic utilities into the file processor's RAM. The screen will display the operating system prompt (A>).

Next, insert the cartridge into the tape drive slot. If you are performing a backup procedure, make sure that the write-protect switch on the tape cartridge *is not* in the **SAFE** position. If you are performing a restoration, ensure that the write-protect switch *is* in the **SAFE** position.



To operate the tape utility, a file on the Diagnostic Diskette called TAPEDISK.DAT must contain the partitions on the hard disk to be backed up. Before beginning the backup procedure, check that this file contains the partition letters that correspond to your system configuration. Type

```
TYPE TAPEDISK.DAT (RETURN)
```

Make sure the drive partitions listed match the partitions for your system configuration. You can find a list of system partitions in Table 4-1, Section 4.1. For example, if you have a Supermicro 32 with a 60 MB drive having 8 partitions, your screen should look like this:

```
A>TYPE TAPEDISK.DAT (RETURN)
BCDEFGJK
A>
```

If the partitions listed do not match your system configuration, you must change the contents of TAPEDISK.DAT. You may do this by using a text editing or word processing program with which you are familiar. Type the letters of the applicable partitions (using no commas, spaces, or other separators), and press RETURN at the end of this character string. The file may contain only the drive partition letters, followed by a return, with no other text, spaces, or data.

After the A>, type

```
TAPE
```

and press RETURN. The screen will display the Tape Backup Menu:

```
TAPE BACKUP UTILITY
VER 1.22A      mm/dd/yy
```

```
B = BACKUP DISK FILES TO TAPE.
R = RESTORE DISK FILES FROM TAPE.
D = LIST TAPE DIRECTORY.
T = RE-TENSION TAPE.
Q = QUIT.
```

```
SELECT OPTION
```

Select the option letter. Do not press RETURN. Enter Q to return to the operating system prompt.

5.4.1 Backing Up Disk Files to Tape

Enter B in the Tape Backup Menu to backup disk files to tape. The screen will display

```
ENTER TODAY'S DATE (mm/dd/yy):
```

Enter the date. Do not press RETURN. The screen will display the date you entered and

```
CORRECT (Y/N)?
```

Enter Y or N. Do not press RETURN. If you enter N, the screen will ask you to re-enter today's date. If you enter Y, the screen will display

```
DO YOU WANT TO BACK UP ALL DISK FILES (Y/N)?
```



Enter Y or N. Do not press RETURN.

Next the screen will display a series of questions. By answering these question you may specify the files to be backed up. Press the RETURN key after each response. To select more than one choice for a question, press RETURN after each choice and a second RETURN to move on to the next question. To select "all" for a particular question, press RETURN as the first response.

The screen will display

DISK NAME OR RANGES (E.G. A OR B-D):

Enter a single CP/M system drive. Enter two letters separated by a dash to indicate a range of CP/M system drives. Press RETURN after each entry. Press RETURN a second time to move on to the next question. The screen will then display

USER NUMBERS OR RANGES (E.G. 0 or 9-15):

Using the same method described above, enter the number or numbers indicating the CP/M User Numbers. The screen will display

FILE NAMES TO BE BACKED UP (* AND ? ALLOWED,
E.G. *.COM, TEST.DAT, OR XYZ.F?M):

Enter the filenames, and press RETURN after each entry. Press RETURN a second time to display the next question. The screen will display

DO YOU WANT TO SPECIFY FILES TO BE EXCLUDED
FROM THE BACKUP (Y/N)?

If you enter Y the screen will display

FILE NAMES TO BE EXCLUDED (SAME FORMAT AS ABOVE):

Enter each filename, and press RETURN. Press RETURN a second time to display the next question. The screen will display

ENTER A DESCRIPTION OF THIS BACKUP TAPE:

Enter a name string, and press RETURN. The screen will display all the parameters of the requested backup and display

ARE ALL THE ABOVE ENTRIES CORRECT (Y/N)?

If you enter N, the program will return to the beginning of the question session. If you enter Y, the screen displays

PLEASE INSERT BACKUP TAPE TO BE WRITTEN.
READY (Y/N)?



If you enter N, the program will return to the Tape Backup Menu. If you enter Y, the screen will display

PREPARING TAPE FOR BACKUP ...

The screen displays the name of each file as it is being written and the total number of files written to tape so far. When the process completes, the screen will display the number of soft (recovered) tape errors and

BACKUP COMPLETED. READY (Y/N)?

A Y or N response will return you to the Tape Backup Menu.

If the tape cartridge is full and the tape backup process is not complete, the screen will display

TAPE FULL, INSERT ANOTHER TAPE FOR
VOLUME x OF THIS BACKUP

where x is the number of the cartridge in sequence.

5.4.2 Restoring Disk Files from Tape

Select R on the Tape Backup Menu to restore the files on the tape cartridge to the hard disk drive. The screen will display

DO YOU WANT TO RESTORE ALL FILES FROM TAPE (Y/N)?

Enter Y or N. Do not press RETURN.

Next, the screen will display a series of questions which will allow you to specify the files to be restored. Press the RETURN key after each response. To select more than one choice for a question, press RETURN after each choice, and press RETURN twice in succession to move on to the next question. To select "all" for a particular question, press RETURN as the first response.

If you enter N above, the screen will display

DISK NAMES OR RANGES (E.G. A OR B-D):

Enter a single letter to indicate a single CP/M system drive. Enter two letters separated by a dash (-) to indicate a range of CP/M system drives. Press RETURN after each entry. Press RETURN twice in succession to move on to the next question. The screen will then display

USER NUMBERS OR RANGES (E.G. 0 OR 9-15):

Using the same method described above, enter the number or numbers indicating the CP/M User Numbers. The screen will display

FILE NAMES TO BE RESTORED (* AND ? ALLOWED,
E.G. *.COM, TEST.DAT, OR XYZ.H?M):



Enter the filenames, and press RETURN after each entry. Press RETURN a second time to display the next question. The screen will display

DO YOU WANT TO SPECIFY FILES TO BE EXCLUDED FROM THE RESTORE (Y/N)?

If you enter Y the screen will display

FILE NAMES TO BE EXCLUDED (SAME FORMAT AS ABOVE)

Enter each filename, and press RETURN. Press RETURN twice in succession to display the next question. The screen displays the parameters of the requested restoration and the question

ARE ALL THE ABOVE ENTRIES CORRECT (Y/N)?

If you enter N, the program will return you to the beginning of the question session. If you enter Y, the screen displays

PLEASE INSERT TAPE TO RESTORE FILES FROM. READY (Y/N)?

If you enter N, the program will return to the Tape Backup Menu. If you enter Y, the screen will display

PREPARING TAPE ...

To ensure that you have inserted the correct tape the screen will display

TAPE BACKUP CREATED ON *mm/dd/yy* (VOLUME *n*).
DESCRIPTION IS: xxxxxxxxxx
OK (Y/N)?

Volume *n* identifies the cartridge sequence. If you enter N, the screen will ask you to insert the tape again. Enter Y to start the recovery. As the process proceeds, the screen will display the name of each file being restored and the total number of files restored. The program searches to the logical end of the tape. When the process is complete, the screen displays

RESTORE COMPLETED. READY (Y/N)?

If the volume 1 tape cartridge is full and there is a volume 2 cartridge, the screen will display

END OF TAPE, PLEASE INSERT VOLUME 2 OF THE SAME BACKUP. READY (Y/N)?



Insert the next cartridge in the backup sequence. For example, the first cartridge is volume 1 and the second cartridge is volume 2. If you insert a cartridge out of sequence, the screen will display

WARNING: THIS IS NOT THE NEXT VOLUME
OF THE SAME BACKUP. OK (Y/N)?

Enter Y to proceed with the cartridge that is inserted. Enter N to tell the program that you are going to insert a different cartridge.

5.4.3 Listing Tape Directory

Enter D in the Tape Backup Menu to list the files on the tape cartridge.

The screen will display

C = LIST TO CONSOLE, P = LIST TO PRINTER,
B = BOTH

Press C, P, or B. The screen will respond with

PLEASE INSERT TAPE CARTRIDGE. READY (Y/N)?

Insert the tape cartridge, and press Y. The screen will display

PREPARING TAPE FOR DIRECTORY LIST ...

When the tape has been prepared, the screen will display

TAPE BACKUP CREATED *mm/dd/yy* (VOLUME 1).
DESCRIPTION IS: *message line*

CONTINUE (Y/N)?

If you have inserted the correct tape, press Y to continue. If you press N, the program will return you to the Tape Backup Menu.

The screen or the printer will list one page of the directory at a time. The program will prompt you with

CONTINUE (Y/N)?

Press Y to list the next page. Press N to return the Tape Backup Menu. Figure 5-3 shows a sample page of a tape directory listing.



Figure 5-3
Example of a Tape Directory Listing

Dsk	Filename	Typ	Usr	Recs	Filename	Typ	Usr	Recs
B:	POSTBOOT	COM	0	9	DUMP	COM	0	4
B:	DOWN	COM	0	9	TAPEDISK	DAT	0	1
B:	TAPEBACK	OVL	0	37	DBIOSN2	HEX	0	22
B:	WSADDS	ASM	1	40	FUN35	COM	3	10
B:	CUSTOMER	LST	4	56	CB80	OV1	3	106
C:	LIB	COM	0	57	SUBMIT	COM	0	10
C:	HERMSA	SUB	1	1	HERMSB	SUB	1	1
C:	HERMSC	COM	2	69	HERMSC	SUB	3	1

5.4.4 Retensioning the Tape

Enter T in the Tape Backup menu to retension the tape. The screen will display

PLEASE INSERT TAPE CARTRIDGE. READY (Y/N)?

Insert the tape cartridge, and press Y. The tape backup unit will begin the retension procedure. While the tape is rewinding and retensioning, the screen will display

RETENSIONING TAPE

When the process is complete, the screen will display

TAPE IS RETENSIONED. READY (Y/N)?

Press Y. Do not press RETURN. The screen will display the Tape Backup Menu.



5.5 TAPE ERROR CODES

When the tape backup program encounters an error, the program aborts the operation in progress and displays

TAPE ERROR

and one of the following messages:

TAPE NOT INSERTED
TAPE DRIVE NOT ONLINE
TAPE WRITE PROTECTED
END OF TAPE REACHED
UNRECOVERABLE DATA ERROR
FILE MARK ENCOUNTERED
ILLEGAL COMMAND TO CONTROLLER
NO DATA ON TAPE
TAPE POSITIONED AT BEGINNING OF TAPE
TAPE RESET OCCURRED

The error message will prompt you for the corrective action. If you wish to return to the operating system, press **BREAK**.

NOTE

If a write operation was in progress when the error occurred, the file in question should be rewritten.



n/STAR OPERATING SYSTEM 6

INTRODUCTION

This chapter describes the n/STAR Operating System. n/STAR is a multi-user program that allows each application processor to operate independently and, at the same time, share files and peripherals.

n/STAR allows each user to run application programs under the CP/M Operating System. You may use all the standard CP/M interfaces, routines, formats and calls. n/STAR also provides enhanced BDOS and CBIOS operations.

n/STAR features include a data security system, shared peripherals, print spooling, and multi-user file sharing. All the n/STAR programs are easy to use; you are guided through the routines with menus and screen-displayed prompts. In addition, the security system provides status reports detailing the security system parameters and system usage.

6.1 n/STAR DISK ORGANIZATION

n/STAR divides each disk on the Supermicro into a number of logical drives. Each logical drive is from five to eight megabytes. Because disk size varies with the Supermicro model, there may be from two to twelve logical drives on one disk. For example, the Supermicro 8 has two logical drives on each disk, and the Supermicro 64 with the 60-megabyte drive has either seven or twelve logical drives on each disk, depending upon how it is configured.

n/STAR identifies each logical drive with a letter. For example, on disk unit 0 the first logical drive is A, the second logical drive is B, and so on. The alphabetical sequence continues with the subsequent disk units.

The diskette is treated as one logical drive. Depending on the type of diskette drive, the logical-drive letter may be G, H, O, or P.

Table 6-1 shows the logical drives contained on each physical drive of the three Supermicro models.

6.2 n/STAR SECURITY SYSTEM TUTORIAL

n/STAR provides data security by dividing logical drives into volumes and allowing users to access the volumes with User IDs and passwords. This section is intended as a tutorial for the first time user of the n/STAR Security System.

Table 6-1. Logical Drives on the Supernicro, Multiuser Mode

	MODEL															
	SMB 10MB	SMB 10MB	SMB 15MB	SUPERMICRO 32 30MB		SUPERMICRO 32 60MB			DIRAC 30MB		SUPERMICRO 64 DIRAC 68 60MB		SUPERMICRO 64X 136MB			
LOGICAL DRIVES SIZE (MB)	2	2	2	3	4	3	4	8	4	6	7	12	3	4	6	12
BLOCKSIZE	5.0	4.7	7.3	9.8	7.6	21.0	15.0	7.7	7.3	4.9	8.0	4.9	45.0	33.0	22.0	8.0
MAX # DRIVES	4/8/16K 3	4/8/16K 3	4/8/16K 3	8/16K 4	4/8/16K 3	16K 4	8K 3	4/8/16 1	8/16K 3	4/8/16K 2	8/16K 1	4/8/16K 1	16K 4	16K 3	16K 2	8/16K 1
HARD DISK 0	A,B	A,B	A,B	A,B,C	A,B,C,D	A,B,C	A,B,C,D	A,B,C,D E,F,I,J	A,B,C,D	A,B,C,D E,F	A,B,C,D E,F,I	A,B,C,D E,F,I,J K,L,M,N	A,B,C	A,B,C,D	A,B,C,D E,F	A,B,C,D E,F,I,J K,L,M,N
HARD DISK 1	C,D	C,D	C,D	D,E,F	E,F,I,J	D,E,F	E,F,I,J	-	E,F,I,J	I,J,K,L M,N	-	-	D,E,F	E,F,I,J	I,J,K,L M,N	-
HARD DISK 2	E,F	E,F	E,F	I,J,K	K,L,M,N	I,J,K	K,L,M,N	-	K,L,M,N	-	-	-	I,J,K	K,L,M,N	-	-
HARD DISK 3	-	-	-	L,M,N	-	L,M,N	-	-	-	-	-	-	L,M,N	-	-	-
DISKETTE-SS/SD	G	G	G	G	G	G	G	G	G	G	G	G	G	G	G	G
DISKETTE-SS/DD	H	H	H	H	H	H	H	H	H	H	H	H	H	H	H	H
DISKETTE-DS/SD	-	-	-	-	-	-	-	-	O	O	O	O	O	O	O	O
DISKETTE-DS/DD	-	-	-	-	-	-	-	-	P	P	P	P	P	P	P	P

(SS/SD=Single sided/single density; SS/DD=Single sided/double density; DS/SD=Double sided/single density; DS/DD=Double sided/double density.)





6.2.1 Dividing Logical Drives into Volumes

The n/STAR Security System divides the logical drives on the hard disks into volumes. A CP/M User Number identifies a volume within a logical drive. There are 16 CP/M User Numbers labeled 0 through 15; therefore, each logical drive may be divided into 16 volumes.

Figure 6-1 shows example volume assignments on the Supermicro 8.

Logical Drive:	A	B	G	H
CP/M User Number:				
0	SYSTEM	ACCOUNT1	FLOPPY	FLOPPY1D
1	USERSYS	NEWS		
2	REPORT01	REPORT02		
3	TIM			
4	INVNTR01			
5	INVNTR02	DAVE		
6				
7	LETTERS			
8	VOL1	VOL2		
9	NORVIN			
10				
11	SUSAN			
12		JOHN		
13		ACCOUNT2		
14				
15	MAINT			

There is one directory on each logical drive. Each listing in the directory contains a filename, the location of the file, and the CP/M user number. Volumes, therefore, partition the logical drive by partitioning the logical drive's directory.

Figure 6-2 gives a schematic illustration of a logical drive directory.

Filename	Location (Extent)	CP/M User Number
LETTERS	3400H	0
LETTERS.BAK	3A80H	0
WS.COM	4280H	0
INVNTR01	3B00H	1
INVNTR02	3680H	1
ACCOUNT	3D80H	3

Each logical drive may have a maximum number of files in its directory (See Table 4-2 for the block and directory sizes available on each Supermicro.) When the directory is full, no more files may be added to any of the volumes on the logical drive. You will receive an error message such as

DIRECTORY FULL

To remedy this situation, you must make room in the logical drive either by deleting a file or by moving a file to another logical drive that has adequate directory space.



6.2.2 Defining Volumes

The user in charge of security maintenance defines each volume by entering volume parameters on the Volume Profile screen. An example of the Volume Profile screen is shown in Figure 6-3.

The volume parameters are: CP/M user number, logical drive letter, volume name, volume-read password (optional), and volume-write password (optional). Section 6.2.3 explains how volume passwords are used.

You may access the Volume Profile screen with the MAINT command. Also using the MAINT command, you may list all the defined volumes on the system. (See Section 6.3.4 for a description of MAINT.)

Figure 6-3
Volume Profile Screen

```
PROFILE OF VOLUME VOL2
  READ PASSWORD  RPW: = ROBERT
  WRITE PASSWORD WPW: = FROST
  LOCATION              FP: = 255
                        DRV: = B
                        USR: = 8

  ACCESS IS (SECURED OR UNSECURED) SECURED
  ENTER COMMAND OR "DEL" TO DELETE THIS VOLUME
  ( █ . )
```

6.2.3 Assigning Volumes to a User ID

Each user is identified by a User ID and an optional user password.

Each User ID may have access to a maximum of 16 volumes at any one time. When n/STAR accesses a volume, it treats the volume as a CP/M user drive. You may use all the current CP/M 2.2 commands to manipulate the files on a user drive.

Each user drive has an identifying letter. For example, when you are on user drive B, the n/STAR operating system prompt for that drive will be

```
B >
```

The letters A through P identify the 16 possible user drives.

Volumes are assigned to each User ID on the User Profile screen. Next to each user drive letter, the user enters the volume name, and after the semi-colon (;) the volume-read password or the volume-write password. See Section 6.2.4 for a description of volume passwords.



Figure 6-4
Sample Volume Assignments in a User Profile

USER ID AND PASSWORD	USR: = PERSON ;PASSWORD
LOGICAL ASSIGNMENTS	LST: = LOCAL
A: = VOL1 ;SECRET	I: = ;
B: = INVNTR01;	J: = NEWS ;
C: = JOHN ;JOHN	K: = ;
D: = ;	L: = ;
E: = ;	M: = ;
F: = VOL2 ;ROBERT	N: = ;
G: = DAVE ;	O: = SYSTEM ;TOPSECRET
H: = ;	P: = FLOPPY1D ;

Using the ASSIGN command, a user may assign volumes to his User Profile. (See Section 6.3.3.) Using the MAINT command, the user in charge of security maintenance may assign volumes to any User Profile. (See Section 6.3.4.)

n/STAR allows any portion of the users to have access to any volume. For example, a volume may be "public" and available to all User IDs, "semi-public" and available to a selected group of User IDs, or "private" and available to only one User ID.

Figure 6-5 illustrates how one volume may be assigned to more than one user.

Figure 6-5
Schematic Example of Volume Assignments

Volumes Names and Their Passwords			
Volume Name	Read Password	Write Password	
SYSTEM	METSYS	TOPSECR	
INVNTR01	ALL	UPDATE	
NEWS	(none)	REPORTER	
LETTERS	LIZ	LIZ	
DOCUMENT	VIEW	TYPE	
Volume Assignments			
User ID:	LIZ	JOAN	FRED
User Drive			
A:	NEWS;	NEWS;	NEWS;REPORTER
B:	LETTERS;LIZ	INVNTR01;ALL	INVNTR01;UPDATE
C:	INVNTR01;ALL		
D:			
E:			
F:			INVNTR02;NEW
G:	REPORTS;ACCT		
H:			
I:			
J:			
K:			
L:			
M:			
D:	DOCUMENT;TYPE	DOCUMENT;VIEW	
O:	SYSTEM;METSYS	SYSTEM;METSYS	SYSTEM;TOPSECR
P:	FLOPPY	FLOPPY	FLOPPY



A particular volume may be assigned to any number of User Profiles by the user(s) in charge of n/STAR security maintenance; or if a user knows a volume name and the volume-read password or the volume-write password, he may assign the volume to one of his User Drives. In this way, users may share some volumes with other users, and still have some volumes which are private.

6.2.4 Assigning Volume Passwords to User Profiles

You may establish two volume passwords in the Volume Profile: a read password and a write password. One of these passwords may then be assigned to a user drive along with the volume name.

If you enter the volume-read password in the User Profile, the user may only read from the files in the volume. If you enter a volume-write password, the user may read and update files in the volume. n/STAR does not require that you specify volume passwords in the Volume Profile. Either password or both passwords may be omitted.

When the Volume Profile does not have a read password or a write password, assign only the volume name to the user drive. All the users with the volume assignment will be able to update files in the volume.

When the Volume Profile has a write password but no read password, assign the volume-write password to allow the user to update the files in the volume. A password is not required, however, to read files in the volume.

When the Volume Profile has a read password but no write password, assign the read password in all volume assignments. In this case the read password allows the user to read and update the files in the volume.

6.2.5 Secured and Unsecured Volumes

By using the Volume Profile, the user(s) in charge of security maintenance may designate individual volumes as either SECURED or UNSECURED.

When a volume is in SECURED mode, n/STAR will make an entry in the lock table each time the user opens one of the files in the volume or locks one of the records. When the program closes the file or unlocks the record, the entry is removed from the lock table.

n/STAR uses the information in the lock table to provide file sharing. By placing a volume in SECURED mode you are enabling the n/STAR file sharing features. It is important that files in multi-user applications always operate under SECURED mode. (See Section 6.8 for a description of file sharing and record locking.)

If a volume is in UNSECURED mode, no entries are made in the system lock table and all file sharing capabilities are disabled. Because UNSECURED mode allows two users to update a record at the same time, the programs should have only single-user applications.



Some CP/M application programs must operate in UNSECURED mode. You will need to use UNSECURED mode when:

- (1) The program opens files repeatedly without closing them. In this case you will receive the error message

FILE LOCK TABLE FULL

- (2) The program continues to read and write to a file after closing it.

If the program displays the error message shown above, or if it fails for unknown reasons, try running it in an unsecured volume. This will be a safe procedure if you ensure that only one user accesses the program at a time.

6.2.6 Directory Search Default

The Directory Search Default is a file search feature that allows the CCP to search more than one user drive for a file. Using this feature, you may store a copy of a file in one user drive and access it from several other user drives. Thus you do not need to keep a copy of frequently used COM files in each user drive.

To instate the Directory Search Default for a file, you must flag the file with \$SYS. Set the \$SYS flag with the n/STAR command SET or the CP/M command STAT. (See the Section 6.4.4 for a description of SET.)

When the \$SYS flag is set, n/STAR will first search for the file in the current user drive. If the file is not found, n/STAR will search for the file in the user drives that alphabetically follow the current user drive. n/STAR will not, however, search for the file in user drives before the current user drive. n/STAR will search only in logical drives to which volumes have been assigned, and will not search the diskette.

An example: A file REPORT.COM has the \$SYS attribute set and is located in user drive N. If the user calls up REPORT.COM while logged onto user drive I, n/STAR will search each successive user drive (I, J, K, L, M, and finally N) until it finds REPORT.COM. n/STAR will not search for REPORT.COM in user drives A, B, C, D, E, F, G, or H.



6.2.7 System Event Logging

System event logging is a feature that records the amount and type of use each User ID gives the system. The Event Log Report shows for each User ID: The amount of logged-on time, the program executed, and the application processor that was used. A sample of the Event Log is shown below:

DATE	TIME	USER ID	UNIT	EVENT	ELAPSED TIME
7/2/82	1:26:38	DAVE	245	LOGON	
7/2/82	1:26:42	DAVE	245	LOGOFF	0:00:04
7/2/82	8:00:45	TOM	190	LOGON	
7/2/82	8:05:34	TOM	190	WS	
7/3/82	10:45:55	TOM	190	LOGOFF	2:45:10
7/3/82	8:13:10	JOAN	210	LOGON	
7/3/82	13:01:55	JOAN	210	ACCT	
7/3/82	14:00:13	JOAN	210	ACCT	
7/3/82	15:15:55	JOAN	210	LOGOFF	7:02:45

System events are entered in the event log file. An entry will be made in the event log if the user

- Logs on.
- Logs off.
- Executes a program.
- Restarts the CCP.

Event logging may also be disabled. Use selection 3 in the MAINT menu to select the event log parameters. (See Section 6.3.4.)

The Event Log file is in the reserved volume MAINT. You may control the maximum size of the event log file by specifying the number of 128-byte records that the file may contain. When the maximum size is reached, event logging will be suppressed and the screen will display

HISTORY.SYS IS FULL

To specify the maximum size of the event log file, use selection 3 in the MAINT menu.

In order to display or print the Event Log, n/STAR must read the event log file from the volume MAINT, and write the file in a formatted form to the current user drive. Selection 4 in the MAINT menu performs this process. (See Section 6.3.4.)

HISTORY.SYS is the name of the formatted file residing in the user drive. Each time you write a new HISTORY.SYS file, the current HISTORY.SYS file will be deleted.



The HISTORY.SYS file has the following format for each logical record:

type,user,unit,date,hh,mm,ss

where

- | | |
|-----------------|--|
| <i>type</i> | is LOGON, LOGOFF, CCP RESTART, or <i>d:filename.typ</i> in double quotes. |
| <i>unit</i> | is the decimal number of the application processor making the entry. |
| <i>user</i> | is the User ID in double quotes. |
| <i>date</i> | is a decimal number indicating the number of elapsed days. Day 1 is January 1, 1978. |
| <i>hh,mm,ss</i> | is the time the entry was made. The numbers are decimal. <i>hh</i> may be from 0 to 23. <i>mm</i> and <i>ss</i> may be from 0 to 59. |

The n/STAR Distribution Diskette includes a sample program showing how the event log file might be processed. The program is located in the file PRTLOG.BAS and is written in CB80 Basic. This source code is provided for the convenience of those users who wish to customize the Event Log Report.

To display the Event Log, type

PRTLOG

after the user drive prompt, and press RETURN. The Event Log will appear on the screen.

To print out the Event Log, type CTRL-P, and press RETURN. The screen will display

(CTRL-P IS ACTIVE)

Then type PRTLOG, and press RETURN. The printer assigned in your User Profile will begin printing.

If the HISTORY.SYS file is not in the user drive, the screen will display

THE FILE 'HISTORY.SYS' WAS NOT
FOUND ON THE DEFAULT DRIVE. JOB TERMINATED

If you receive this message, at least one of the two following conditions apply:

1. You have not retrieved the event log file from the MAINT volume. (Use selection 4 in the MAINT menu.)
2. The event log is disabled. (Use selection 3 in the MAINT menu.)



6.3 n/STAR SECURITY SYSTEM COMMANDS

The n/STAR Security System uses the following commands:

LOGON
LOGOFF
ASSIGN
MAINT

LOGON allows you to access the n/STAR Security System.

LOGOFF allows you to exit from n/STAR.

ASSIGN allows you to maintain your User Profile and user password.

MAINT allows the system maintenance user to maintain the User Profiles, Volume Profiles, system password, and initial commands for each application processor. MAINT should not be used by anyone other than the User ID(s) responsible for maintaining the security system.

6.3.1 LOGON

When you log off from n/STAR, the screen displays the logged-off screen. On each new system delivered, this log-on screen is the Molecular Computer logo. You may customize this screen. See Section 6.9.5.

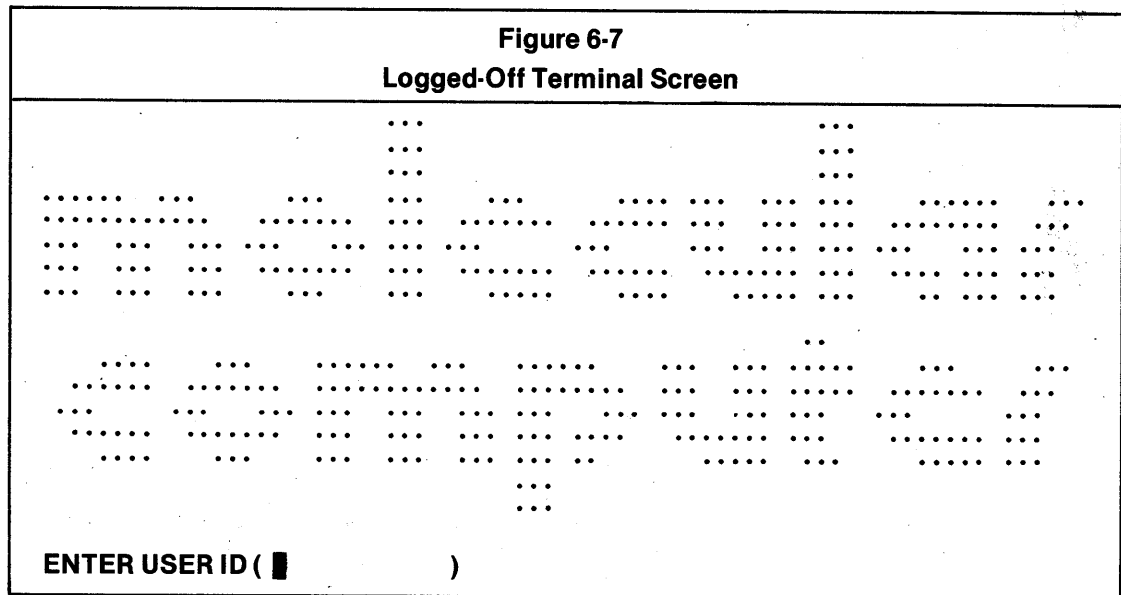

To log on to the Security System, enter a valid User ID, and press RETURN. (If your User ID is eight characters, do not press RETURN. In this case an automatic RETURN will process your entry.)



If you have a User Password assigned in your User Profile, the screen will display

ENTER PASSWORD

Enter your User Password, and press RETURN. (If your password is eight characters, do not press RETURN.)

The screen will display

- n / S T A R -

(c) 1982 Molecular Computer

nnnnK Z80 Vmm.uup UNIT = xxx USER = yyyyyyyy

A>

where

nnnnK	is the amount of RAM (in bytes) in the AP
Vmm.uup	is the major revision level, update level, and system patch level of n/STAR
UNIT = xxx	is the unit address of the AP
USER = yyyyyyyy	is the USER ID

You are now ready to enter commands.

6.3.2 LOGOFF

The LOGOFF command prevents the terminal from using the system until a user logs on.

To exit from the n/STAR Security System, enter

LOGOFF

and press RETURN. The screen will display the log-on screen.

6.3.3 ASSIGN

The ASSIGN command allows you to modify your User Profile.

To display your User Profile, type

ASSIGN

and press RETURN.

If your User Profile specifies a password, the screen will display

ENTER YOUR PASSWORD

Enter your user password, and press RETURN. (If your password is eight characters, do not press RETURN. In this case an automatic return will process your entry.)

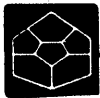

The screen will display your User Profile.

```

                                Figure 6-8
                                User Profile Screen

                                n/STAR Resource Assignment Program

                                Profile of User JOAN

PASSWORD    PW:=SECRET

LOGICAL ASSIGNMENTS

A:=JOAN      ;           I:=          ;           LST:=SPOOL CP
B:=WSDEMO    ;           J:=          ;
C:=INVNTRO1;ALL  K:=SUE      ;
D:=          ;           L:=SCALC    ;ADDITION
E:=CB80      ;           M:=          ;
F:=          ;           N:=          ;
G:=          ;           O:=SYSTEM   ;METSYS
H:=          ;           P:=FLOPPY   ;

INITIAL COMMAND

CMD:=

ENTER COMMAND ( █ )

```

You may enter the commands described below. Press RETURN after each entry.

PW:= password

Changes your user password. *password* may be up to eight characters.

drive:= volume {;password}

Assigns a volume name and volume password to a user drive. To remove a volume from a user drive, enter *drive* but leave *volume* and *password* blank.

drive may be any one of the user drive letters shown on the User Profile screen.

volume must be a volume name that has been established in the Volume Profile. If you enter an invalid volume name, n/STAR will not accept the entry.

password may be either the volume's read password or write password. *password* may be omitted if no passwords are specified in the Volume Profile. See Section 6.2.4 for a description of assigning volume passwords to User Profiles.

LST:= printer

Specifies the method of printing. *printer* may be one of the following entries:

SPOOL {queuename}	(See Section 6.6 for a
LOCAL	description of these
SYSTEM	commands.)

LOCAL is the default.



`CMD:=initial`

Instructs n/STAR to call up a COM file each time the user logs on. This is useful if you have only one type of activity to perform on the system.

initial is the name of the COM file. For example, `CMD:=WS` will cause the Wordstar file `WS.COM` to execute automatically each time the user logs on.

After each entry, press RETURN, and the screen will display an updated version of the User Profile. Press RETURN a second time to return to the user-drive prompt.

You may use this command without displaying the User Profile screen. Enter ASSIGN followed by one of the commands listed above. For example:

```
ASSIGN LST:=LOCAL
```

6.3.4 MAINT

NOTE

The utility MAINT should only be used by those responsible for maintaining the n/STAR Security System. To access MAINT, you must know the System Password.

The MAINT command allows the privileged user to maintain the security system. By making selections from the MAINT menu, you may:

- Change the system password.
- Create and maintain User IDs and User Profiles.
- Define and maintain Volumes Profiles.
- Define the event log parameters.
- Move the event log file to a user drive.
- Print User Profiles and volume directories.
- Establish application processor parameters.

Type

```
MAINT
```

and press RETURN.

The screen will display

```
ENTER SYSTEM PASSWORD
```

Enter the system password, and press RETURN. (If the password is eight characters, do not press RETURN. In this case an automatic RETURN will process your entry.)



The screen will display the MAINT menu.

Figure 6-9 Maintenance Menu
ENTER FUNCTION CODE 0) CHANGE THE SYSTEM PASSWORD 1) USER MAINTENANCE 2) VOLUME MAINTENANCE 3) EVENT LOG CONFIGURATION 4) GET HISTORY LOG FILE 8) PRINT USER AND VOLUME DIRECTORIES 9) SYSTEM CONFIGURATION PRESS RETURN TO EXIT (■)

Enter a number menu selection. Do not press RETURN, an automatic RETURN will process your selection.

The following subsections describe the MAINT menu selections.

Change the System Password

If you select 0 in the MAINT menu, the screen will display

ENTER THE NEW SYSTEM PASSWORD

Enter up to eight characters, and press RETURN. The screen will then display

AGAIN PLEASE

Repeat the entry. This ensures that you did not make a typographical error while entering the new password. If the two entries do not match, the password will not be changed.

If you do not want the MAINT command protected with a system password, enter a space (press the spacebar) for the new system password. Thereafter when you enter MAINT, the MAINT menu will automatically display on the screen.

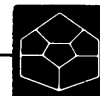

User Maintenance

This menu selection allows you to create new User IDs and maintain User Profiles.

Select 1 in the MAINT menu. The screen will display a list of all the User IDs that are currently defined on the security system. Figure 6-10 shows an example of this screen.

Figure 6-10 Current User Screen						
CURRENT USERS						
PERSON	JOAN	R2D2	ET	DAVE	ERIC	409A
LIZ	FRED	TOM	POPPINS			
ENTER A USER ID (█)						

To update a User Profile, enter one of the User IDs on the screen, and press RETURN. (If the User ID is eight characters do not press RETURN.) To create a new User Profile, enter up to eight characters, and press RETURN. The screen will then display the User Profile screen. Figure 6-11 shows an example of a User Profile screen.

Figure 6-11 User Profile Screen	
USER ID AND PASSWORD	USR: = JOAN ;SECRET
LOGICAL ASSIGNMENTS	LST: = SPOOL
A: = NEWS ;ALL	I: = ;
B: = INVNTR01;ALL	J: = ;
C: = ;	K: = ;
D: = ;	L: = ;
E: = ;	M: = ;
F: = ;	N: = DOCUMENT ;VIEW
G: = ;	O: = SYSTEM ;METSYS
H: = ;	P: = FLOPPY ;
INITIAL COMMAND	
CMD: =	
ENTER COMMAND OR "DEL" TO DELETE THIS USER	
(█)	

You may enter the commands described below. Press RETURN after each entry.

PW: = *password*

Changes or assigns a user password. *password* may be up to eight characters.

***drive*: = *volume* {*password*}**

Assigns a volume name and volume password to a user drive. To remove a volume from a user drive, enter *drive* but leave *volume* and *password* blank.

drive may be any one of the user drive letters shown on the User Profile screen.



volume must be from a volume that has been established in the Volume Profile. Note: n/STAR will allow you to assign invalid volume names. Each time you enter an invalid name, however, n/STAR will display the following error message:

WARNING** INVALID ACCESS

password may be either the volume's read password or write password. *password* may be omitted if no passwords are specified in the Volume Profile. See Section 6.2.4 for a description of assigning volume passwords to User Profiles.

LST: = *printer*

Specifies the method of printing. *printer* may be one of the following entries:

SPOOL (See Section 6.6 for a
LOCAL description of these
SYSTEM commands.)

LOCAL is the default.

CMD: = *initial*

Instructs n/STAR to call up a COM file each time the user logs on. This is useful to the user who has only one type of activity to perform on the system.

initial is the name of the COM file. For example, CMD: = WS will cause the Wordstar file WS.COM to execute automatically each time the user logs on.

DEL

Use this command to delete a User Profile.

Press RETURN after each entry. The screen will display an updated version of the User Profile. Press RETURN a second time to return to the Current User screen.

Volume Maintenance

If you select 2 in the MAINT menu, the screen will display a list of all the volumes currently defined on the security system. Figure 6-12 shows an example of the Current Volume screen.

Figure 6-12 Current Volume Screen					
CURRENT VOLUMES					
SYSTEM	FLOPPY	FLOPPY1D	FLOPPY2D	VOL1	VOL2
TIM	VOL3	INVNTR01	INVNTR02	NEWS	DAVE
LETTERS	DOCUMENT	REPORTS			
ENTER A VOLUME NAME (█)					



To update a Volume Profile, enter one of the volume names on the screen, and press RETURN. (If the volume name is eight characters, do not press RETURN.) To create a new Volume Profile, enter up to eight characters, and press RETURN. The screen will then display the Volume Profile screen.

```
Figure 6-13
Volume Profile Screen
PROFILE OF VOLUME VOL2
READ PASSWORD   RPW: = ROBERT
WRITE PASSWORD  WPW: = FROST
LOCATION          FP: = 255
                DRV: = B
                USR: = 8
ACCESS IS (SECURED OR UNSECURED) SECURED
ENTER COMMAND OR "DEL" TO DELETE THIS VOLUME
( █          )
```

You may enter the commands described below. Press RETURN after each entry.

RPW: = *password*

Specifies a read password for the volume. *password* may be up to eight characters. See Section 6.2.4 for a description of volume passwords.

WPW: = *password*

Specifies a write password for the volume. *password* may be up to eight characters. See Section 6.2.4 for a description of volume passwords.

FP: = *address*

address is 255 for all current n/STAR installations.

DRV: = *logical*

Specifies the logical drive letter. See Table 6-1 for a list of the logical drive letters on each Supermicro model.

USR: = *number*

Specifies the CP/M User Number for volume. The CP/M User Numbers range from 0 to 15.

SECURED/UNSECURED

See Section 6.2.5 for an explanation of secured and unsecured volumes. SECURED is the default.

DEL

Use this command to delete a volume.



After each entry, press RETURN. The screen will then display an updated version of the Volume Profile. Press RETURN a second time to return to the user drive prompt.

n/STAR allows you to assign two volume names to the same volume location. If you assign a second volume name to the same location, n/STAR will display

```
**WARNING** LOCATION IN USE VOL:name  
... PRESS ANY KEY TO CONTINUE
```

where *name* is the name of the volume already assigned to that location. If you wish to keep the entry you have just made, press any key. If not, re-enter the volume name.

Event Log Configuration

If you select 3 in the MAINT menu, the screen will display the event log parameters.

Figure 6-14 EVENT LOG PARAMETERS	
SWITCH: = 0	
0 - NO EVENT LOGGING	
1 - LOG USER LOGON AND LOGOFF	
2 - LOGON PROGRAM EXECUTION	
MAX: = 0	
0 - NO LIMIT ON THE SIZE OF THE EVENT LOG	
NONZERO - MAXIMUM FILE SIZE FOR THE EVENT LOG	
(VALUE MUST BE LESS THAN 65535)	
ENTER COMMAND (█)	

System event logging allows you to specify the maximum size of the log and the events that will be recorded in the Event Log. (See Section 6.2.6 for a description of system event logging.)

You may enter the commands described below. Press RETURN after each entry.

SWITCH: = *selection*

Selects the events that will be entered in the log. The values of *selection* may be:

- 0 No event logging.
- 1 Include user LOGON and LOGOFF.
- 2 Include user LOGON, LOGOFF, and program execution.

0 is the default.

MAX: = *number*

Specifies the maximum number of 128-byte records that the system event file may include. *number* must be less than 65,535. If you enter 0, the size of the system event file will be unlimited.

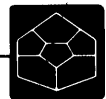

Get Event Log File

If you select 4 in the MAINT menu, the n/STAR operating system will read the event log file from the volume MAINT and write a formatted file to the current user drive. (See Section 6.2.6 for a description of system event logging.)

The screen will briefly display

PROCESSING THE SYSTEM EVENT LOG FILE

and then return you to the MAINT menu.

The name of the formatted file is HISTORY.SYS. The current HISTORY.SYS file and the current event log file in the volume MAINT are deleted. Therefore if you enter 4 again without logging off, the screen will display

NO HISTORY FILE

Print User and Volume Directories

This menu selection allows you to print the User Profile Directory and the Volume Directory. The User Profile Directory is a listing of all the User Profiles. The Volume Directory lists for each volume: volume name, processor number, logical drive letter, CP/M User Number, and the user IDs assigned to the volume.

If you enter 8 in the MAINT menu, the screen will display

ENTER USER OR VOLUME (U/V):

Enter either U or V. Do not press RETURN, an automatic RETURN will process your entry. Enter U to print the User Profiles. Enter V to print the volume assignments.

If you enter U, the printer will begin to print the User Profile Directory. If you enter V, the screen will display

SORT BY NAME OR LOCATION? (N/L):

Enter N to sort the volume list by name. Enter L to sort the volume list by location. Do not press RETURN. The screen will display

INCLUDE USER XREF? (Y/N):

Enter Y to include the users assigned to each volume. Enter N if you do not want the users included. The printer will begin printing after your entry.



VOL: SYSTEM	FP: 255	DRV: A	USR: 00	(RW-)
VOL: INVNTR01	FP: 255	DRV: A	USR: 04	(RW-)
VOL: LETTERS	FP: 255	DRV: A	USR: 07	(RWU)
VOL: VOL1	FP: 255	DRV: A	USR: 08	(RW-)
VOL: MAINT	FP: 255	DRV: A	USR: 15	(--)
VOL: NEWS	FP: 255	DRV: B	USR: 01	(-W-)
VOL: VOL2	FP: 255	DRV: B	USR: 08	(R--)
VOL: FLOPPY	FP: 255	DRV: G	USR: 00	(--)

The right-hand column in Figure 6-15 consists of three fields. Each field may have one of two entries. They are:

[R] [W] [U]

R in the first field indicates a read password has been assigned to the volume. A dash (-) indicates no read password has been assigned.

W in the second field indicates a write password has been assigned to the volume. A dash (-) indicates no write password has been assigned.

U in the third field indicates the volume is UNSECURED. A dash (-) indicates the volume is SECURED.

System Configuration

Enter 9 in the MAINT menu to establish the parameters of an application processor. The screen will display

ENTER A M/BUS UNIT ADDRESS

Enter the unit address of the application processor. n/STAR currently allows units addresses from 0 to 255. 255 is always the address of the file processor. If the address is either one or two digits, press RETURN after the entry. If the address is three digits, do not press RETURN.



The System Configuration screen will display.

```
Figure 6-16. System Configuration Screen

Configuration of unit xxx

BAUD RATE FOR THE CONSOLE SERIAL PORT
C:=9600

BAUD RATE FOR THE PRINTER SERIAL PORT
P:=9600

INITIAL COMMAND
CMD:=LOGON TOM

RTS LOW ON PORT A CAUSES A REBOOT (YES OR NO) RTS:=NO
DTR LOW ON PORT A INHIBITS OUTPUT (YES OR NO) DTR:=NO

ENTER COMMAND
( )
```

You may enter the commands described below. Press RETURN after each entry.

C:= *baud*

Sets the baud rate for the console serial port. *baud* may be: 110, 150, 300, 1200, 2400, 4800, 9600, and 19200. The default is 9600. Your terminal must support the baud rate you select. After you enter a baud rate, change the physical baud rate setting on your terminal.

The baud rate for the console port may also be set using the SETBAUD command described in Section 6.4.5.

P:= *baud*

Sets the baud rate for the printer serial port. *baud* may be: 110, 150, 300, 1200, 2400, 4800, 9600, and 19200. The default is 9600. Your printer must support the baud rate you select. After you enter a baud rate, change the physical baud rate setting on your terminal.

The baud rate for the console port may also be set using the SETBAUD command described in Section 6.4.5.

CMD:= *initial*

The initial command lets you establish a start-up process for each application processor. Thereafter, when the processor is started wither by starting the system, logging on, or resetting the processor, the initial command is executed. NOTE: The initial command in this MAINT selection is not the same as the initial command in a User Profile.



CMD:=LOGON {username}

When the initial command is LOGON, the security system is automatically invoked. (See Section 6.9 for a description of operation without the security system.) The application processors on new systems have LOGON as their initial command.

CMD:=NEWCON {name}

When the initial command is NEWCON, the application processor can be used as a system resource processor using the TLINK command described in Section 6.4.9. The optional name lets you specify a unique or nonunique name for the processor. If no name is supplied, the name "NSTAR80" is used. If you have more than one processor with the same name, TLINK will simply acquire one of the processors of that name that is not currently acquired.

CMD:=DESPOOL (param1) (param2)

If the application processor is to be used as a despooler, the initial command uses (param1) to describe the printer attached to port A (the console port) and (param2) to describe the printer attached to the port B (the printer port).

param1 and *param2* have the following form:

{'banner',}name,{rate},protocol

'banner' is the optional text for the first banner line. When specified, this text prints as part of the banner for each job printed. The banner actually consists of three lines of text, printed at the top of two consecutive pages prior to printing the text of the job itself. The format is as follows

Line 1 - banner text
Line 2 - volume name
Line 3 - file name

If banner is omitted from the device specification, no banner is printed, that is, lines two and three are also suppressed.

name may be up to eight characters. More than one spooling printer may be assigned to the same name. In this case, printing is directed to the first printer available with that name.



rate is a decimal value from 0 to 7 defining the baud rate of the printer. The values of *rate* are:

0	110 baud
1	150 baud
2	300 baud
3	1200 baud
4	2400 baud
5	4800 baud
6	9600 baud
7	19200 baud

The default is the value set by the C:= or P:= commands.

protocol may be:

0	ETX/ACK protocol and a buffer-full position.
1	DTR handshaking or XON/XOFF protocol.

1 is the default. If the printer is capable of both ETX/ACK and XON/XOFF, 1 is the preferred entry.

For example, two printers are connected to one application processor: a daisy-wheel printer requiring XON/XOFF protocol is on port A, and a matrix printer requiring ETX/ACK protocol is on port B. The printer on port A is to have no banners printed, while the printer connected to port B is to print a banner which includes the text "SYSTEM 2 PRINTER." The command form is:

```
CMD:=DESPOOL (DAISY,,1) (' SYSTEM 2 PRINTER',MATRIX,,0)
```

RTS:=yes/no

If RTS low is selected, the processor performs a coldstart (equivalent to a BREAK) when RTS on the console port goes low. This causes the currently logged user to be logged off. This feature is helpful to automatically log off remote terminals when the user "hangs up" the modem.

DTR:=yes/no

If DTR low is selected, the computer will send data to the terminal only when DTR is high. This allows some models of terminals to control the flow of characters to and from the computer.



6.4 OTHER n/STAR COMMANDS

There are a variety of commands available to the user under n/STAR which are not available under CP/M. The n/STAR commands are described in this section.

6.4.1 D (Directory Utility)

Use the D command to display the directory of files in a volume. The file list appears on the screen in alphabetical order. Next to each filename is the file size rounded up to the next 1K byte, and an indicator for the file attributes.

This command has two forms:

D	Will display all the files in the directory.
D <i>afn</i>	Will limit the list to the files that satisfy the ambiguous file reference <i>afn</i> .

6.4.2 DEVICES

n/STAR acquires and releases devices (printers, diskette drives, and system resource application processors) as they are needed by various applications. You can use the DEVICES command to list the currently created devices, their attributes, and their owners.

To list the currently created devices, type

DEVICES

and press RETURN. A typical display of device assignments might be:

name	unit	type	flag	owner
NSTAR86	195	TLink	X	0
NSTAR86	196	TLink	X H	252

where

name	is the name of the device
unit	is the unit address of the device
type	is the access type of the device, where
device	is a printer, diskette drive, or other device
TLink	indicates access through TLINK
queue	is the entry for an MP/M queue
flag	is the access control parameters for the device, where
X	exclusive use
K	keep (cannot be deleted)
H	hard acquire (retain device after warm start)
owner	is the processor that currently has access to the device



6.4.3 DOWN

Use the DOWN command to turn off the system power. See Section 3.5 for a detailed description of the power-down procedure.

6.4.4 QMAINT

Use the QMAINT command to view, reorder, or delete despool requests. The Queue Activity Report lists all the despooling printers and their condition.

To display the Queue Activity Report, enter

QMAINT

and press RETURN. Press RETURN a second time to return to the user drive prompt.

Figure 6-17 Queue Activity Report		
QUEUE ACTIVITY REPORT		
QUEUE: DAISY	ACTIVE:1	PENDING: 2
MATRIX	ACTIVE:1	PENDING: 2
ENTER QUEUE NAME OR COMMAND: (█)		

You may enter the commands described below. Press RETURN after each entry.

HOLD *queue*

Suspends a queue from further processing.

RELEASE *queue*

Releases the HOLD command on a queue and continues the processing.

HOLD *unit{/port}*

Suspends an application processor or a single port on the application processor from further processing.

unit is the application processor number.

port may be:

- A Console port.
- B Printer port.

If you do not enter *port*, both ports will be in the hold condition.

RELEASE *unit {port}*

Releases the HOLD command on an application processor or a port.

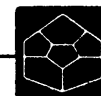

queue

Displays the Queue Maintenance screen for a particular queue. *queue* is the name of the printer.

Figure 6-18 Queue Status Screen			
QUEUE: MATRIX			
ACTIVE REQUESTS			
UNIT: 250/01	VOL1:MEM01.DOC	UNIT:250/02	VOL1:MEM02.DOC
PENDING REQUESTS			
1) VOL1:LETTER.TXT		2) VOL1:FILENAME.TYP	
3) VOLUME2:REPORT.MAY		4) VOL1:MEMO3.DOC	
5) VOLUME2:PROGRAM.LST			
NOTE: POSITION) <VOLUME NAME> : <FILENAME> .<TYPE>			
ENTER COMMAND:(█)			

The Queue Maintenance screen allows you to inspect and modify the activity for each queue. To return to the Queue Activity screen, press RETURN.

Note: Each request in a queue has the following form:

position) volume:filename.typ

where

position is the request location in the queue.

volume is the name of the volume that contains the file.

filename.typ is the unambiguous filename.

You may enter the commands described below. Press RETURN after each entry.

HOLD *unit {/port}*

(Described on the previous page.)

RELEASE *unit {/port}*

(Described on the previous page.)

CANCEL *volume:filename.typ*

Deletes a request from the queue.

TOP *volume:filename.typ*

Places a request at the top of the queue.



BOTTOM *volume:filename.typ*

Places a request at the bottom of the queue.

UP *volume:filename.typ {count}*

Moves a request up through the queue. *count* is the number of positions that the request will be moved. *count* is optional; if you do not enter *count*, the queue request will move up one position.

DOWN *volume:filename.typ {count}*

Moves a request down through the queue. *count* is the number of positions that the request will be moved. *count* is optional; if you do not enter *count*, the queue request will move down one position.

CTRL-X

Cancels a command. This is the same as the CP/M CTRL-X.

6.4.5 RESET

Use the RESET command to perform a reset request on a specified processor. You occasionally need to reset a processor to which you are physically not connected, such as an application processor connected to despooling printers, or a system resource application processor, such as an AP/86. These devices cannot be reset by pressing a BREAK key, because in most cases, they have no keyboard.

To reset an application processor, type

RESET unitnumber

where

unitnumber is the unit number (in decimal) of the application processor to reset.

NOTE

Resetting an AP/86 takes several seconds. Therefore, if you invoke TLINK immediately after RESET, the TLINK program may not "find" the AP/86, because it has not finished the reset operation. If this occurs, wait a few seconds and try again.

The RESET program resides in the SYSTEM volume and may normally be used by any user. However, your system manager may restrict access to the RESET program by moving it to another, secured volume.



6.4.6 SET

Use the SET command to set and reset selected file attributes. SET has the forms described below. Press RETURN after each entry.

SET *afn* \$LCK Resets the shared attribute.

SET *afn* \$SHR Sets the shared attribute.

SET *afn* \$NCL Resets the partial-close attribute.

SET *afn* \$PCL Sets the partial-close attribute.

SET *afn* \$R/W Resets the read-only attribute.

SET *afn* \$R/O Sets the read-only attribute.

SET *afn* \$DIR Resets the system attribute.

SET *afn* \$SYS Sets the system attribute.

SET *afn* \$MOD Resets the archive attribute.

SET *afn* \$ARC Sets the archive attribute.

afn may be any valid, ambiguous filename. The indicators R/W, R/O, DIR, and SYS are the same as the commands with the same name in the CP/M STAT command. A file backup utility will normally set the archive attribute. n/STAR always resets the archive attribute whenever the file has been modified.

For example, to instate the directory search default for the program ASSIGN.COM, enter

```
SET O:ASSIGN.COM $SYS
```

(See Section 6.2.5 for a description of directory search default.)

To display the list of SET commands on the screen, type

```
SET
```

and press RETURN.

6.4.7 SETBAUD

Use the SETBAUD command to set the baud rate for the printer or the console port on your application processor.

Enter

```
SETBAUD
```

The screen will display

```
C = CONSOLE PORT P = PRINTER PORT
```



Enter C or P. Do not press RETURN, an automatic return will send your entry to the computer. The screen will display

A = 110	E = 2400
B = 150	F = 4800
C = 300	G = 9600
D = 1200	I = 19200

DESIRED BAUD RATE

Enter one of the letter options. Do not press RETURN. Your terminal must support the baud rate you select.

The screen will display

COMPLETE - PRESS "CTRL-S" TO RESTART,
"CTRL-C" IF DONE

Change the baud rate setting on the terminal to the rate that you have entered. When you are done, press CTRL-C. If you wish to restart the set-baud procedure, press CTRL-S.

6.4.8 SUBMIT

n/STAR supports the CP/M SUBMIT command and all applications which generate SUBMIT files. To accommodate the multi-user environment, n/STAR renames each SUBMIT file and gives it the following form:

`$nn.SUB`

`nn` is a unique pair of characters associated with the application processor. For example, unit 192 generates SUBMIT files with the name `$3F.SUB`. This procedure is performed within n/STAR and is transparent to the application program.

6.4.9 TLINK

Use TLINK to access a "system resource" application processor from your application processor. Your system may have one or more optional AP/86 Performance Accelerators, and may also have "extra" standard Z80 application processors, all of which are available to all users as system resources. The TLINK command causes your terminal to act as the terminal for the application processor to which it is linked. TLINK also uses the listing device (established by the LST:= statement in the ASSIGN command) of the processor running TLINK.

To link to a system resource application processor, type

`TLINK {devicename}`

where

`devicename` is an optional parameter giving the name assigned to the system resource application processor.



If the device name is omitted, TLINK displays the menu of Figure 6-19, allowing you to specify the device to which to link by menu selection number. The device name for all AP/86 application processors is "NSTAR86." The default device name for all Z80 system resource application processors is "NSTAR80." (This name may be changed to any other desired device name using the NEWCON command described in Section 6.3.4.)

```
Figure 6-19. TLINK Main Menu

Terminal Communication Program

Enter Function Code

A) Acquire available n/STAR86 processor
B) Acquire available n/STAR80 processor

hit "RETURN" to exit (■)
```

To acquire and link to a system resource Z80 application processor, your system manager must configure the application processor (item 9 in the MAINT menu) so that the initial command CMD:=NEWCON. Refer to "System Configuration" in Section 6.3.4 for a complete description of the NEWCON command.

After you select or specify a device name, TLINK attempts to acquire an available device with that name. If the acquire device request is successful, TLINK links to the device and turns control of that device over to your terminal's application processor. The processor initializes and displays the following information

```
- n / S T A R -
(c) 1982 Molecular Computer
nnnnK processor Vmm.uup Unit = yyy
```

where

nnnnK is the number of bytes of RAM on the AP

processor is the type of processor (Z80, 8086, etc.)

Vmm.uup is the version number of n/STAR or n/STAR86, where

```
mm is the major revision level
uu is the update level
p is the system patch level
```

yyy is the unit number



You may now proceed to run applications as desired. If a device was not found or not available, TLINK displays an appropriate error message. By acquiring the device, n/STAR allows you to exit from TLINK, you retain ownership (control) of the device and return to it later, if necessary.

If you want to return to TLINK while your linked application is still running, type

CTRL-]

TLINK will then return to the TLINK main menu, which will now include options for controlling the linked device, as shown in figure 6-20.

<p>Figure 6-20. TLINK Main Menu, AP/86 Device Acquired</p> <p>Terminal Communication Program</p> <p>Enter Function Code</p> <ul style="list-style-type: none">A) Acquire available n/STAR86 processorB) Acquire available n/STAR80 processor 1) Resume communication with NSTAR86,yyy2) Release NSTAR86,yyy3) Reset NSTAR86,yyy 4) Select NSTAR86,yyy <p>hit "RETURN" to exit (■)</p> <p>NOTE: yyy = application processor unit number</p>

From the main menu, you may link to another system resource application processor (if available), and run another application independent of the first. You can continue this process of returning to TLINK and linking to other available application processor, up to a maximum of five. Each time you link to another processor, the TLINK main menu grows to allow you control of each linked device.

The main menu lists the following options:

A) Acquire available n/STAR86 processor

This option lets you acquire and link to an AP/86 application processor and run n/STAR86.

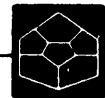

B) Acquire available n/STAR80 processor

This option lets you acquire and link to an "extra" Z80-type application processor which has been configured by the system manager to run NEWCON as its initial command (CMD:=NEWCON).

1) Resume communication with NSTARnn,yyy

This option returns you to the acquired processor (nn) whose unit number is (yyy). In other words, it returns you to one of your acquired applications.

2) Release NSTARnn,yyy

Use this option to release one of your acquired application processors when you no longer need it. You should routinely release unneeded application processors, to allow other users access to them.

3) Reset NSTARnn,yyy

Use this option when you need to execute a "BREAK" on one of your acquired processors.

4) Select NSTARnn,yyy

Use this option to select among your acquired devices. As you acquire more devices, additional "Select" options are added to the menu to allow you to choose any of your acquired application processors. As you select various acquired processors, items nn and yyy in options 1-3 above will change to indicate the currently selected processor.

If you exit from TLINK to perform some other command, you can return to TLINK by typing

TLINK

and RETURN. You will then see the TLINK menu of Figure 6-21.

You may now choose to acquire another system resource application processor, or to return to any of your existing acquired applications.

Although a reset option is available in the TLINK main menu, there may be times when you need to reset the acquired processor but cannot return to TLINK to do so. In these cases, you must use the RESET command described in Section 6.4.5 to perform the reset.



Figure 6-21. Returning to TLINK, AP/86 Device Acquired

```
Terminal Communication Program

Enter Function Code

A) Acquire available n/STAR86 processor
B) Acquire available n/STAR80 processor

4) Select NSTAR86,yyy

hit "RETURN" to exit (■)

NOTE: yyy = application processor unit number
```

6.4.10 TOD

Use the TOD command to display the date and time on the screen or to reset the date and time. You must reset the date and time whenever the system is turned on.

The TOD command has the following forms:

TOD

Displays the day, date, and time.

TOD P

Gives a continuous display of the date and time. Stop the display by pressing any key on the keyboard.

TOD *mm/dd/yy hh:mm*

Resets the date, and time. Enter the numeric representation for the date. Enter *hh* and *mm* in military time. After you enter this command, the screen will display

STRIKE ANY KEY TO SET TIME

Strike a key at the moment you want the time entry to start.

6.4.11 WHO

Use the WHO command to list the processors on the system, their type, and the contents of their processor command (CMD:=) line.



To list processors, type

WHO

and RETURN. A typical display follows:

Unit	Type	Logged
195	AP86	
196	AP	LOGON
201	AP	NEWCON REMOTE
203	AP	LOGON GLEN
226	AP3	LOGON
235	AP	LOGON RHONDA
240	AP	LOGON
241	AP	LOGON MIS
243	AP	DESPOOL (CP) ('SYSTEM 2 LP',0)
250	AP	LOGON
254	FS	LOGON
255	FP	

where

Unit is the bus address (unit number) of the processor

Type is the type of processor, where

AP	is a Z80 model 8001
AP3	is a Z80 model 8003 (19.2K baud)
AP86	is an AP/86 Performance Accelerator
FS	is a file server
FP	is the system file processor

Logged is the processor command line, where

LOGON username	indicates the processor is logged onto
DESPOOL param	indicates a dedicated despooling job
NEWCON name	indicates a system resource AP

Note that the WHO command does not include password data, thus the integrity of your data is preserved.

6.5 DISKETTE ACCESS UNDER n/STAR

Before accessing the diskette drive, make sure a diskette is in the drive, and the volume FLOPPY or FLOPPY1D is assigned to your User Profile. Use FLOPPY1D for single-sided, double-density diskettes. Use FLOPPY for single-sided, single-density diskettes. See Section 6.9.5 for a description on assigning the diskette volumes to User Profiles.



NOTE

Only one user may access the diskette drive at a time.

To access the diskette drive, type

d:

where *d* is the letter of the user drive containing the volume FLOPPY or FLOPPY1D. The diskette volume directory will be read by n/STAR, the allocation table will be built, and the diskette drive will be assigned to that user. The screen will display

d >

If the diskette drive is in use by another user, the following error message will appear on the screen

BDOS ERROR ON *d*: DRIVE IN USE

You must release the diskette drive in order for another user to access it. Do this by accessing another user drive and pressing CTRL-C.

If you remove a diskette and insert another diskette after the diskette drive has been accessed, you must reset the drive. Reset the diskette drive by pressing CTRL-C.

6.6 PRINTER OPERATION

The n/STAR operating system provides three modes of printing. You may install a printer as a local printer, a system printer, or a despooling printer. This section describes each of these methods.

6.6.1 Local Printer

A local printer connects to port B (printer port) of an application processor. (See Section 2.3.2 for a description of this connection.) This printer is a single-user printer.

In your User Profile, enter

LST:=LOCAL

This command will assign the local printer as the CP/M LST device. You may also use your local printer with the command

LIST *filename.typ* LOCAL

This command overrides the printer assignment in your User Profile. For example, if you have SYSTEM assigned in your User Profile, you may print the file REPORT.FIL on your local printer with the command

LIST REPORT.FIL LOCAL



6.6.2 System Printer

A system printer connects to port B (printer port) on the file processor. See Section 2.3.2 for a description of this connection.

All User IDs who have

```
LST:=SYSTEM
```

in their User Profiles share the system printer. This command will assign the system printer as the CP/M LST device.

You may also use the system printer with the command

```
LIST filename.typ SYSTEM
```

This command overrides the printer assignment in your User Profile.

Enter CTRL-Q to attach the system printer to your terminal. The screen will display

```
(SYSTEM PRINTER IS ATTACHED)
```

Enter CTRL-Q again to release the printer to another user. Only one user may access the system printer at a time; if another user tries to access the printer, the screen will display

```
BDOS ERROR: SYSTEM PRINTER IN USE
```

CTRL-P will also attach and release the system printer, as well as instating and releasing the ECHO function. When you instate the ECHO function, everything that appears on the screen will also print on the printer.

Logging off also releases the printer.

6.6.3 Despooling Printer

A despooling printer is one attached to a dedicated application processor which has been configured for despooling. Each despooling application processor can support two printers, one connected to the A (terminal) port, and one connected to the B (printer) port. In addition, you can establish as many despooling printers as you have application processors to support them. See Section 2.3.2 for a description of printer cabling.

When using an applicatin processor for despooling, you must define the name, baud rate, and protocol for each despooling printer. You also may supply an optional banner, which will print at the beginning of each job to identify the owner and the file printed. To define these items, use selection 9 in the MAINT menu. (See Section 6.3.4 for a description of the MAINT facility.)



During despooling, a number of users share one or several despooling printers. Files to be printed are placed into a printing queue, then printed as soon as they come to the top of the queue.

The printing queue is a waiting line of printing requests. The purpose of the queue is to maintain an orderly procession of the files waiting to be printed. When a user requests a file to be printed, the file starts at the bottom of the queue; the file moves up through the queue as previous requests are printed.

A despooling printer may be used for printing existing files or for printing files that have been spooled.

Despooling Existing Files

To print an existing file on a despooling printer, type

```
LIST filename.typ {queuename}
```

where `queuename` is the name of the despooling printer established by your system manager in the MAINT facility, and `filename.typ` is an unambiguous file name. You may omit `queuename` if the printer on which you want to print is the one assigned to your list device in your User Profile.

Spooling

If you specify

```
LST:=SPOOL {queuename}
```

in your User Profile, a disk file with the name `$nnSPOOL.***` is created whenever you generate CP/M print output. Each time you generate additional print output, it is appended to this file, so at a given time, you have only one spool file, no matter how many print jobs you have spooled.

The contents of `$nnSPOOL.***` will print whenever your Application Processor does a warmstart or a coldstart. A warmstart usually occurs whenever you exit a program, or when you press CTRL-C. A coldstart is accomplished by logging on, pressing BREAK, or otherwise resetting the processor.

If you want to print the contents of `$nnSPOOL.***` without doing a coldstart or a warmstart, type

```
LIST
```

If your User Profile list specification includes a `queuename`, the spool file will be queued to the assigned despooling printer.



If your User Profile does not specify a queue name, or if you want to print on a despooling printer other than the one specified as your list device, type

LIST SPOOL queue name

Your file will then be queued to the despooling printer specified by queue name.

If you want to print the contents of \$nnSPOOL. \$\$\$ on a local or system printer, type

LIST SPOOL LOCAL

or

LIST SPOOL SYSTEM

Any printer name other than LOCAL or SYSTEM implies a despooling printer. Specifying an undefined despooling printer will cause the file to wait in the queue until a physical printer is assigned to the queue, or until you cancel the print job using a QMAINT command. Refer to Section 6.4.4 for a description of QMAINT.

The command LIST renames \$nnSPOOL. \$\$\$ to the following format:

\$nn\$xxxxx.SPL

where

nn is a unique number associated with the application processor

xxxxx is a sequential number identifying the renamed \$nnSPOOL. \$\$\$ file.

After \$nn\$xxxxx.SPL is printed, it is deleted from your directory.

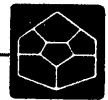

For example, SPOOL MATRIX is the CP/M list device in your User Profile. You want to print a WordStar file on the despooling printer. Enter the usual WordStar print commands. The WordStar main menu will indicate that the file is being printed, when, in fact, it is not printing, but is copying the print file to a spooling disk file. The spooling file has the name form: \$nnSPOOL.\$\$\$\$. When the WordStar screen indicates printing is complete, you may print the contents of the spooling file. Exit the WordStar program, and type

LIST

The file will print on the printer specified in your LST:= assignment, in this case, MATRIX. The file positions at the bottom of the printing queue and prints when it comes to the top of the queue.

6.7 OPERATION WITHOUT THE SECURITY SYSTEM

When the initial application processor command is LOGON, the security system will automatically be invoked. The initial application processor command is established on the System Configuration screen. (See Section 6.3.4.)

If no initial command is specified, then the application processor will run in CP/M mode. When under CP/M, the application processor operates without the benefit of n/STAR features such as User IDs, volumes, and record/file locking. In this mode the USER xx command is operable.

6.8 FILE AND RECORD LOCKING

The n/STAR Operating System allows three methods of locking records and files: automatic file locking, CP/M file sharing, and enhanced file sharing.

No special programming is required for automatic file locking and CP/M file sharing. See Section 7.2.3 for a description of the installation of enhanced file sharing.

6.8.1 Automatic File Locking

If no file sharing is indicated, automatic file locking will be instated. Automatic file locking allows a number of users to read from a file at the same time. The first user to write on a file will lock the file. A second user may read from the file in its locked state, but if he attempts to write on the file, he will receive the following error message

```
BDOS ERROR ON d: FILE IN USE
FUNCTION nn FILE ufn
```

where

<i>d</i>	is the user drive where the locked file was encountered.
<i>nn</i>	is the number of the BDOS function being performed.
<i>ufn</i>	is the unambiguous filename.



6.8.2 CP/M File Sharing

CP/M file sharing allows users with existing CP/M applications written without a record-locking mechanism to take advantage of n/STAR's file sharing capabilities.

To instate Share Mode under CP/M file sharing, you must flag the participating files with \$SHR. Set \$SHR with the n/STAR command SET. (See Section 6.4.4.)

When the program requests a disk access for a particular file, n/STAR under Share Mode creates an entry in an internal locking table. This indicates that the file is to be shared, and the automatic record locking mechanism is to be invoked. (See Section 7.2.2 for a programming description of CP/M File Sharing.)

If a user attempts to read a record already locked by another user, the system will automatically hold the request until the first user either:

1. Reads a different record.
2. Writes (updates) a record in the same file.
3. Closes the file.

There are several assumptions and limitations which must be considered when implementing Share Mode on existing CP/M application programs.

1. It is assumed that a program must read a record before writing it. Because the automatic record locking only takes place on a read operation, applications which write records before reading them should not be used in Share Mode. Records that are added to the end of a file will not be locked by the write operation but will be locked on any subsequent reads.
2. Application programs which close files and then continue to read and/or write records, will encounter errors on such read or write attempts. Files must be opened and closed properly in order for automatic record locking to function. A file attribute called Partial Close Attribute (\$PCL) may be set on files that are processed by applications that do not follow this rule.

Use the SET command described in Section 6.4.4 to flag files with \$PCL. When the \$PCL flag is set, a close request from an application will perform all normal file-close operations, retain the file lock entries, and allow subsequent reads and writes.

3. Programs using indexed files may cause large portions of the file to be locked at a given time. When an index record is read, other users will be unable to read that index record, and all data records under the control of the index record, until another index record is read, the index record is rewritten, or the index file is closed.

Share Mode works well providing you adhere to the considerations outlined above. It is recommended that Enhanced File Sharing be utilized for applications designed to be used by multiple terminals against a common data base.

Existing applications which can not be run efficiently with these restrictions can operate safely in a single-user environment by placing the files in an Unsecured volume. (See Section 6.2.5 for a description of unsecured volumes.)

When files residing in unsecured volumes are accessed, all n/STAR file and record locking mechanisms are inhibited. All other capabilities such as read-only files are maintained.

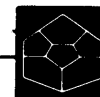

6.8.3 Enhanced File Sharing

Enhanced File Sharing allows files to be opened in Unlocked mode. If a file is opened in Unlocked Mode, multiple users can access the file at the same time. Once the file has been unlocked, it is the responsibility of the application program to control the locking and unlocking of records. (See Section 7.2.3 for a description on how to install Unlocked Mode.)

6.9 USING THE SECURITY SYSTEM FOR THE FIRST TIME

This section describes the recommended procedure for installing the security system for the first time. Before you establish your own security system, read the n/STAR Security System Tutorial in Section 6.2, and experiment with the test security system already established on your Supermicro.

6.9.1 Volumes Already on the Hard Disk

Each Supermicro is shipped with the following volumes installed on the hard disk: SYSTEM, MAINT, FLOPPY, FLOPPY1D, and SAMPLE.

The volume SYSTEM is on logical drive A, CP/M User Number 0. SYSTEM contains the n/STAR Operating System utilities. See Appendix B for a list of the files in volume SYSTEM.

The volume MAINT is on logical drive A, CP/M User Number 15. This volume is not accessible to n/STAR users.

The volume FLOPPY is on logical drive G, CP/M User Number 0. FLOPPY contains the n/STAR diskette utilities for a single-sided, single-density diskette.

The volume FLOPPY1D is on logical drive H, CP/M User Number 0. FLOPPY1D contains the n/STAR diskette utilities for a single-sided, double-density diskette.

The volume SAMPLE is on logical drive B, CP/M User Number 0. SAMPLE has a blank directory.

6.9.2 Getting to Know the Security System

Molecular Computer installs a minimal security system in each Supermicro before it is shipped. This security system has the following User IDs and volume assignments:

User ID	User Drive A	User Drive B	User Drive 0
MAINTUSR	SYSTEM	FLOPPY	—
DEMO	SAMPLE	—	SYSTEM

Before you establish your own security system, experiment with the n/STAR commands using these User IDs and volumes. You will use the MAINT command to establish additional security system parameters. Section 6.3 describes the n/STAR security system commands.

No passwords have been established on the system. Press RETURN each time the screen prompts you for a password.



6.9.3 Step One - Create a Volume called USERSYS

The n/STAR operating system utilities are in the volume SYSTEM. SYSTEM is also the portion of the diskette that is updated by new n/STAR releases and updates. The files in SYSTEM, therefore, could be deleted by any user who has SYSTEM assigned to his User Profile.

Because of its importance to the system, the volume SYSTEM should not be assigned to any User Profile. Instead, create another volume called USERSYS, and copy the files from SYSTEM into USERSYS. Assign USERSYS to User Profiles leaving the volume SYSTEM as a backup to USERSYS.

USERSYS may be identical to SYSTEM, or it may contain a portion of the n/STAR files. You may select subsets of the SYSTEM files for selected groups of users. The minimum information in the USERSYS volume is the COM file LOGOFF. See Appendix B for a list of the SYSTEM files.

6.9.4 Step Two - Define the Volumes

First you must determine the volumes the users on the system will need. When creating volumes, consider the amount of data that will be kept in each volume. Remember that all volumes defined for a logical drive share the available directory space and data storage space. (See Section 6.2.1 for a description of directory space in a logical drive.)

Use the "Volume Identification Chart" in Appendix C for a schematic representation of the volume assignments. Enter on the chart the volumes that are already defined on the system. Then enter the names and passwords of the volumes that you will establish.

Using selection 2 of the MAINT menu, establish a profile for each volume (See Section 6.3.4). The volumes USERSYS, SYSTEM, and MAINT should be password protected. The volume SAMPLE may be deleted.

6.9.5 Step Three - Assign Volumes to User IDs

After you have defined the volumes, assign volumes to User IDs. Using selection 2 in the MAINT menu, establish each User ID, and assign volumes to User Profiles.

Each User Profile must have a valid volume name assigned to user drive A. If you do not assign a valid volume to user drive A, you will receive a BDOS error message when logging on. See Section 6.10.1 for a description of security system recovery.

It is recommended that USERSYS be placed in User Drive O. With this arrangement, the n/STAR files can be retrieved when the CCP is in User Drives A through N. All the n/STAR files in USERSYS have been flagged with \$SYS. The CP/M files have not been flagged with \$SYS. Flag the CP/M files that you wish to access under the Directory Search Default. (See Section 6.3.6 for a description of Directory Search Default.)

FLOPPY (FLOPPY1D) should be placed in User Drive P. FLOPPY is placed after SYSTEM to prevent the CCP from searching the diskette for the n/STAR files. If FLOPPY is before USERSYS and the diskette drive is empty, you will receive a BDOS select error message in response to an n/STAR command.



NOTE

The Molecular Computer logo displays on the first 22 lines on all logged off terminals. The message file is a standard text file that is compatible with CP/M command ED and with WordStar. The message file is named MESSAGE.SYS and is in the volume SYSTEM. This message may be modified by the user.

6.10 SECURITY SYSTEM RECOVERY

Security system recovery is necessary when terminals are locked out of the security system.

6.10.1 When One Terminal is Locked out of n/STAR

A terminal will be locked out of n/STAR if an invalid volume name is assigned to user drive A. The screen will display the following message:

```
BDOS ERROR ON A: SELECT
```

To remedy this situation, you must access MAINT from another terminal using another User ID. Reassign a valid volume name to the locked User Profile, and exit from MAINT.

Press the BREAK key on the locked out terminal. The screen will display the prompt for user drive A (A >).

6.10.2 When All the Terminals are Locked out of n/STAR

All the terminals may be locked out of n/STAR if all the User IDs are assigned an invalid volume name to their user drive A, or if the system password is forgotten.

To recover the security system, you must reinstall the security system using the following procedure:

1. Configure the hardware for diagnostic mode. (See Section 2.3.2 for a description of the hardware configuration.)
2. Start-up the system. (See Section 3.4 for a description of starting up in diagnostic mode.)
3. Type

```
USER 15
```

and press RETURN. Then type

```
ERA B:VECTORS.SYS
```

and press RETURN.

4. Configure the system for multi-user mode. See Section 2.3.2 for a description of the hardware configuration.
5. Start-up the system. (See Section 3.1 for a description of starting up in multi-user mode.)
6. Enter the command MAINT. Establish a new password and valid User Drive A volumes. Using selection 9 in the MAINT menu, re-establish the system configuration parameters.



n/STAR PROGRAMMER'S GUIDE

7

The n/STAR Operating System provides a general environment for program construction, storage, and editing, along with assembly and program check-out facilities. n/STAR is compatible with CP/M application programs.

n/STAR is a multi-console operating system designed specifically for the Supermicro series of computers manufactured by Molecular Computer. No method is provided to implement n/STAR on other computer systems.

7.1 n/STAR SYSTEM INTERFACE

7.1.1 Memory Layout

When the boot load sequence completes, n/STAR allocates the RAM memory space in the file processor into the following sections:

- (1) Contents of EPROM. n/STAR reserves a memory space in both the file processor and the application processor for the contents of EPROM. The EPROM includes the driver routines, interrupt vectors, parity-error handler, bus drivers, and disk drivers.
- (2) Disk buffer pool. The disk buffer pool occupies the area above the boot image for the application processor.
- (3) Application processor boot image. This area of memory contains a static image of the application processor routines. n/STAR loads these routines into the application processor each time the user initiates a BREAK or a cold start. By retaining the application processor boot image in RAM, the application processor boot operation is faster and does not compete with disk I/O.
- (4) Buffered disk driver. This driver manages the buffer pool and reforms the 1024-byte physical sectors to 128-byte blocks.
- (5) Hub module. This portion of RAM services all file-oriented BDOS calls generated by each application processor.
- (6) Application processor request table. Each application processor in the system has an entry in this table.
- (7) Post boot block. This contains the post boot routines for the application processor and the file processor.

Figure 7-1 shows a graphic representation of file processor memory layout.

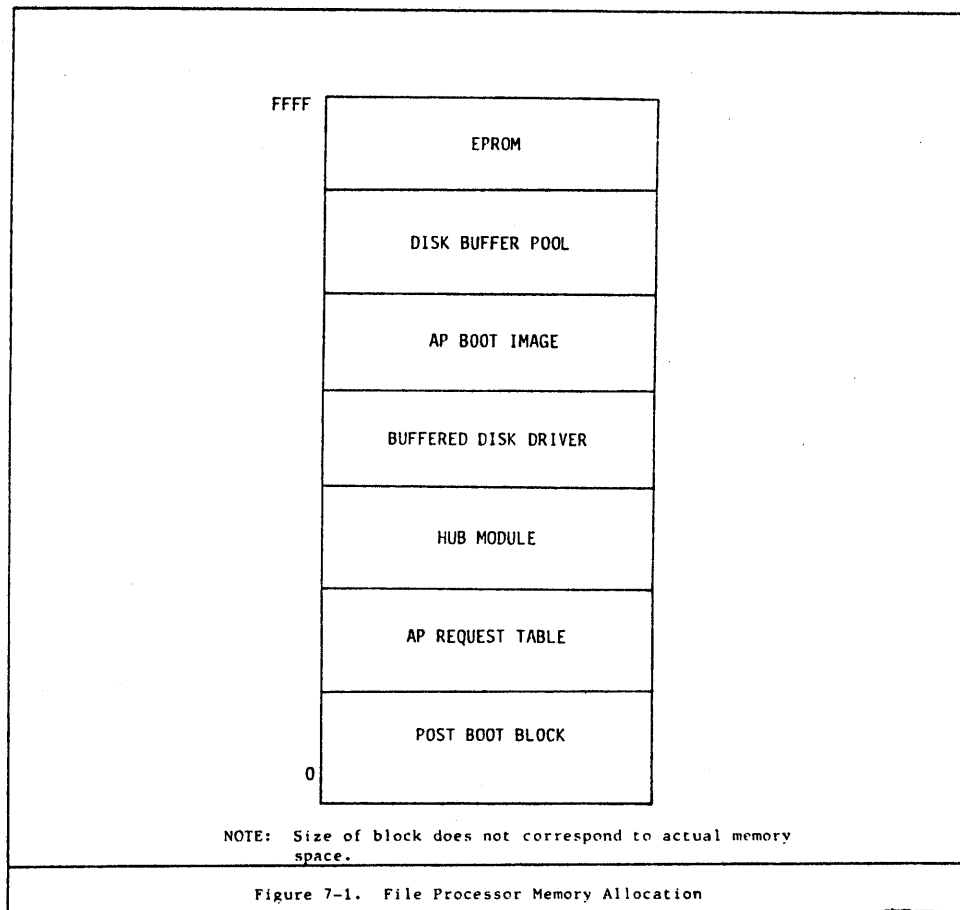

n/STAR allocates the RAM memory space in the Z80 application processor into the following sections:

- (1) Contents of EPROM. The EPROM module is at the top of the memory map. The EPROM contains the bus driver, parity-error handling for memory, bootstrap routines, and interrupt vectors. n/STAR reserves space in the EPROM area for a simulated CBIOS jump-vector table. This permits programs to perform directory console I/O via the jump-vector table. Any jump-vector calls that are disk related result in an error trap because there is no physical I/O link from the application processor to the disk.
- (2) Star module. This module processes all BDOS calls from the application programs and performs console I/O operations. The I/O operations transfer all disk-related functions to the Hub module in the file processor.
- (3) Console Command Processor (CCP). This program interprets the n/STAR commands. Application programs may overlay this module to obtain more RAM space.
- (4) Transient Program Area (TPA). This is the portion of RAM available to application programs.
- (5) System parameters. This system parameter area is equivalent to the system parameter area in CP/M. It contains the warm start, BDOS entry vectors, default sector buffer, and FCB.

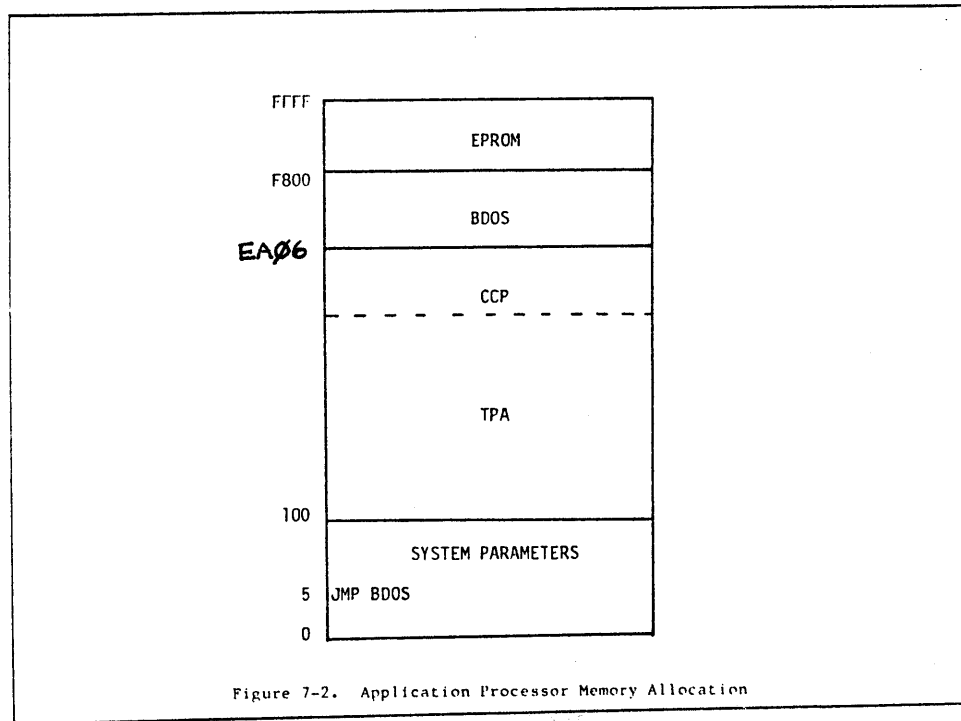
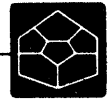

7.1.2 BDOS Functions

This section provides detailed information for performing operating system calls from user programs.

The user should note that the register passing conventions are the same as CP/M. Access to BDOS functions is accomplished by passing a function number and information address through the primary point at location `BOOT+0005`. In general, the function number is passed in register C with the information address in the double-byte pair DE. Single-byte values are returned in register A. The functions added to CP/M to create n/STAR are listed on the pages that follow.



42	Lock Record
43	Unlock Record
45	Set BDOS Error Mode
50.21	Reset m/BUS Unit
104	Set Date and Time
105	Get Date and Time
155	Get Date and Time
158	Attach List
159	Detach List
160	Set List
161	Conditional Attach List
164	Get List Number
240.1	Cold Starting
240.2	Get n/STAR Revision
240.3	Warm Starting
240.10	Create Device
240.11	Destroy Device
240.12	Acquire Device
240.13	Conditional Acquire Device
240.14	Release Device
240.15	Read First Device
240.16	Read Next Device

The individual functions are described in detail in the pages that follow.

Function 42: Lock Record

Entry Parameters:

Register C: 2Ah
Register DE: FCB Address

Returned Value:

Register A: Return Code

The Lock Record function allows the application program to "own" individual records (sectors) within a random access file. This prevents other application programs within the system from accessing the record while it is being updated.

The File Control Block (FCB) must refer to a file which has been declared "unlocked" by opening the file with indicator F5. The FCB must also contain the number of the 24-bit random record (bytes r0, r1, and r2). The indicated record need not reside in an allocated block of the file.

The Lock Record function verifies that the indicated record has not been locked by another application program. All locked records for a given application program are freed either by the Close File function or by a warm start.



If the operation was successful, the Lock Record function returns 0 in register A. If the record is already locked by another application program, the Lock Record functions returns 08h in register A. If the file is not opened "unlocked", locking will not be performed, and register A will always contain 0.

Function 43: Unlock Record

Entry Parameters:

Register C: 2Bh
Register DE: FCB Address

Returned Value:

Register A: Return Code

The Unlock Record function allows the application to "free" records previously locked with function 42. Entry parameters are similar to function 42. The record referred to by the random record count (bytes r0, r1, and r2) must have been previously locked with function 42. Register A always contains 0.

Function 45: Set BDOS Error Mode

Entry Parameters:

Register C: 2Dh
Register E: BDOS Error Mode

Returned Value: none

The Set BDOS Error Mode function determines how physical and extended errors are handled for a process. The Error Mode can exist in three modes: The Default Mode, Return Error Mode, and Return and Display Error Mode. This Function covers the errors listed in Table 7-1.

Table 7-1
Physical Error Codes

01	Bad Sector
02	Drive Read-Only
03	File Read-Only
04	Bad Drive Number
05	File in Use
06	FCB Checksum Error
07	File Password Error
08	File Already Exists
09	? in File Name
10	Open File Limit Exceeded
11	Lock Table Full
12	System in Use
13	Drive in Use
14	System Printer is in Use

In the Default Mode, BDOS displays a system message identifying the error. The Default Mode also terminates the calling process.



In the Return Mode, BDOS sets register A to 0FFh (255 decimal), places an error code identifying the physical or extended error in the four low-order bits of register H, and returns to the calling process.

In Return and Display Mode, BDOS displays the system message before returning to the calling process. No system messages are displayed when BDOS is in Return Error Mode.

Function 45 sets the BDOS Error Mode for the calling process to the mode specified in register E. If register E is set to 0FFh (255 decimal), the Error Mode is set to Return Error Mode. If register E is set to any other value, the Error Mode is set to the Default Mode.

Function 50.21: Reset m/BUS Unit

Entry Parameters:

Register C: 50 (direct BIOS call)

Registers DE: DBC address

Returned Value: none

The Reset n/BUS Unit function allows the application program to reset designated application processors. The format of the direct BIOS call parameter block (DCB) is:

DB	21	code for unit reset
DW	unit	unit to reset
DW	00FE ₁₆	reset operation code

You should note that it takes several seconds to reset an AP/86 Performance Accelerator AP.

Function 104: Set Date and Time

Entry Parameters: 68h

Register C: TOD Address

Register DE:

Returned Value: none

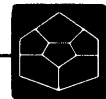

The Set Date and Time function sets the system clock. The TOD address is the address of a four-byte block in the following format:

Byte 0 - 1:	Date Field
Byte 2:	Hour Field
Byte 3:	Minute Field

A 16-bit integer represents the date with day one corresponding to January 1, 1978. Two BCD digits represent the hour and the minute. This function will reset the seconds counter to zero.

Function 105: Get Date and Time

Entry Parameters:

Register C:	69h
Register DE:	TOD Address

Returned Value: TOD

The Get Date and Time function obtains the value of the system clock. The TOD address is the address of a four-byte block to receive the TOD value. The format of the block is described in function 104 above.

Function 155: Get Date and Time

Entry Parameters:

Register C:	9Bh
Register DE:	TOD Address

Returned Value: TOD

The Get Date and Time function returns the value of the system clock. The TOD address is the address of a five-byte block to receive the TOD value in the following format:

Byte 0 - 1:	Date Field
Byte 2:	Hour Field
Byte 3:	Minute Field
Byte 4:	Second Field

The date is represented as a 16-bit integer with day one corresponding to January 1, 1978. The hour, minute, and second fields are stored as two BCD digits.

Function 158: Attach List

Entry Parameters:

Register C:	9Eh
-------------	-----

Returned Value: none



The Attach List function attaches the list device specified in the last Set List function or specified by the ASSIGN LST:= command. BDOS does not return control to the calling program until the device is attached. This suspends execution if the requested list device is attached to another unit.

The Attach List function is automatically called before the first data character is sent to the printer.

Function 159: Detach List
Entry Parameters:
Register C: 9Fh
Returned Value: none

The Detach List function detaches the current list device. If the list device is not attached, no action takes place. This function is used to release the system printer after a print operation.

Function 160: Set List
Entry Parameters:
Register C: A0h
Register E: List Device
Returned Value: none

The Set List function detaches the current list device. This function saves the list device parameter as the device to attach on the next Attach List function.

The list device numbers have been assigned as follows:

0	Local Printer
1	System Printer
2	Spooling Printer

Unlike MP/M II, this function does not attach the specified list device.

Function 161: Conditional Attach List
Entry Parameters:
Register C: A1h
Returned Value:
Register A: Return Code



If the list device is currently unattached, the Conditional Attach List function attaches the list device specified in the last Set List function or in the ASSIGN LST:= command.

If the requested list device is currently attached to another unit, the function returns a value of OFFh in register A. This indicates the list device can not be attached. The function returns a value of zero to indicate that either the list device is already attached or that a successful attach operation was made.

Function 164: Get List Number

Entry Parameters:

Register C: A4h

Returned Value:

Register A: List Device

The Get List Number function returns the value of the list device from the last Set List function or the ASSIGN LST:= command.

The list device numbers have been assigned as follows:

0	Local Printer
1	System Printer
2	Spooling Printer

Function 240.1: Cold Starting

Entry Parameters:

Register C: 240

Register B: 1

The cold starting function informs n/HUB that the processor is cold starting. n/HUB will then request all file processors to unlink all files, destroy any devices, and release any devices associated with the processor.

Function 240.2: Get n/STAR Revision

Entry Parameters:

Register C: 240

Register B: 2

Registers DE: revision location

Returned Value:

Register A: Return Code

Revision is where DE pointed



The Get n/STAR Revision function allows the application to query the operating system to determine its revision. Register DE points to an 8-byte buffer where the n/STAR system revision number is located. The format of the revision number is

mm.uup

where

mm is a major revision level
uu is the update level
p is the system patch level

The return code in the A register indicates whether the revision code place in the buffer before the request is the same as the current system revision. Therefore, an application may place a revision number in the buffer to which DE points, then get the N/STAR revision number, which returns the actual system revision and indicates whether it is different from the code the application stored. Values returned in the A register are:

0 the revision matches
1 the system revision is greater than the given revision
2 the system revision is less than the given revision

This function of the operating system is used to check whether a program is running under a release of n/STAR that it requires. The function only checks the "mm.uu" portion of the revision number, so patch levels are not significant.



```

Function 240.3: Warm Starting

Entry Parameters:
    Register C: 240
    Register B: 3

Returned Value:  none

```

The warm starting function informs n/HUB that the processor is warm starting. n/HUB will then request all file processors to unlink all files and release any implicitly acquired devices associated with this processor.

Device Control Block Format

BDOS functions 240.10 through 240.16 use a standard device control block (DCB) to supply required information. Information is supplied as needed, and most calls update the information in the DCB.

The device control block has the following format:

n1 n2 n3 n4 n5 n6

n1	n2	n3	n4	n5	n6	n7	n8	t1	u1	l1	l2	l3	l4	f1	o1	o2
----	----	----	----	----	----	----	----	----	----	----	----	----	----	----	----	----

00 01 02 03 04 05 06 07 08 09 10 11 12 13 14 15 16

where

n1...n8 the name of the device. This is used to find the device and need not be unique. For example, there could be several devices named "NSTAR86," an acquire would find an available one.

- t1 the type of device, where:
- 1 "device" (link information goes in the drive translate table or otherwise to access the device)
 - 2 "TLINK system resource" (link information addresses the buffer information block for terminal-type communications)
 - 3 "queue" (link information addresses the queue buffer address for m/BUS queue operations)



- u1 the m/BUS unit number of the device.
- l1...l4 information to aid the acquirer in linking to the device
(this is the interpreted base on the device type informa-
tion described in t1 above)
- f1 the access flags for the device, where
- 01 mutual exclusion device; if ON, only one process
 may acquire the device at any given time
 - 02 cannot be deleted; if ON, this entry cannot be
 destroyed.
 - 04 hard acquire; used when acquiring to specify that
 the device is not to be released on a cold start.
 Applies only to mutual exclusion devices.
- Other bits are reserved for system definition.
- o1...o2 the owner of the device. A value of zero means not busy,
otherwise, this is the bus unit number of the device owner.
The creator should either set this field to zero to make
the device available, or put the creator's number here to
acquire the device as soon as it is created (after which a
release is required to make the device available). The
second byte is reserved for future expansion.

Rules for Matching DCBs

When an application passes a device control block to the system, its values are compared field-by-field with the descriptions of the devices already created. The rules n/STAR uses for comparing the different fields are:

- n1...n8 the names are compared byte for byte. Like CP/M file names, all processors use uppercase ASCII characters with trailing blanks, with the top bit of each byte OFF. Also like CP/M file names, the character "?" matches any character.
- t1 the type is compared as a whole byte. A zero in the DCB will match anything, thus you can search for a particular type of device, or for any device of a given name.

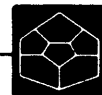

- u1 type unit is compared as a whole byte. A zero in the DCB will match anything. (A zero indicates that the actual location of the device is not important; therefore, neither the unit nor the link information is checked.)
- 11...14 if the unit number is non-zero, this field is compared byte by byte.
- f1 this field is not compared.
- o1...o2 this field is not compared.

DCB Error Codes

When comparing DCBs, error codes are returned in the A register. If an error occurs, A is non-zero. The error codes are:

- 00 success
- 01 device already exists
- 02 device does not exist (not returned by CREATE)
- 04 not allowed access (not returned by CREATE)
- 05 device is in use (not returned by CREATE)
- 06 improper device name
- 11 no table space for new entry

Function 240.10: Create Device

Entry Parameters:

- Register C: 240
- Register B: 10
- Registers DE: DCB Address

Returned Value:

- Register A: Return Code

The create device request function makes the specified device available for later acquires and releases. Registers DE point to a device control block that specifies the device to be created.

The device control block must contain the complete name for the device (no question marks), and the type, unit, link information and flags for the device. The application may create the device for its own use by putting the owner's number into the owner field. On the other hand, if the device is to be made available for use, the owner field must be zero.



A device, once created, will exist either until a destroy request is performed for that device, or until the processor that created the device does a coldstart. A device will never be destroyed if the "cannot be deleted" flag is set.

Function 240.11: Destroy Device

Entry Parameters:

Register C: 240
Register B: 11
Registers DE: DCB Address

Returned Value:

Register A: Return Code

The destroy device request function destroys a previously created device entry.

Function 240.12: Acquire Device

Entry Parameters:

Register C: 240
Register B: 12
Registers DE: DCB Address

Returned Value:

Register A: Return Code

The acquire device request function allows access to the specified device. The device name in the DCB specifies which device to acquire, and, if the acquire is successful, the DCB is returned with all other information in place.

The specified device will remain acquired until a release request or until a warm start. If the named device is in use, the application will suspend until the device becomes available (or until it is destroyed). The application must pass a DCB specifying which device to acquire.

The "hard acquire" bit in the flags byte of the DCB indicates whether the device is to remain acquired until either a warmstart or a coldstart. If the bit is OFF, a warmstart or a coldstart of the acquiring processor will release the device. If the bit is ON, and the device is an exclusive use device, a warmstart will not release the device. This is the only bit used in the flags byte during an acquire.



Function 240.13: Conditional Acquire Device

Entry Parameters:

Register C: 240
Register D: 13
Registers DE: DCB Address

Returned Value:

Register A: Return Code

The conditional acquire device request function is identical to the acquire device request function, except if the specified device is in use, an error code is returned rather than letting the application suspend.

Function 240.14: Release Device

Entry Parameters:

Register C: 240
Register B: 14
Registers DE: DCB Address

Returned Value:

Register A: Return Code

The release device request function releases the specified device.

Function 240.15: Read First Device

Entry Parameters:

Register C: 240
Register B: 15
Registers DE: DCB Address

Returned Value:

Register A: Return Code

The read first device request function returns the DCB of the "first" device that may be acquired and prepares the system for sequential reading of all devices via the read next device request function. The devices are returned at random, in no particular order. Of there are no created devices, the error "device does not exist" is returned.

Nothing in the DCB is used by this request.



Function 240.16: Read Next Device

Entry Parameters:

Register C: 240
Register B: 16
Registers DE: DCB Address

Returned Value:

Register A: Return Code

The read next device request function returns the DCB of the next device. A read first device request function must precede this request. If there is no next device, the error "device does not exist" is returned. The information from the previously executed read first or read next device request is used to find the next device.



7.1.3 Interrupt Vectors

n/STAR provides fixed-interrupt vectors within the EPROM space. These may be used by application programs requiring interrupt-driven I/O. As part of the initialization sequence, the EPROM routine loads the Z80A I register with F6h and sets each vector register in the on-board devices so that it will point to its fixed vector.

Since the ERPOM routines reside in RAM, the vectors may be loaded with the addresses of user-supplied service routines. The application program need only issue the ENABLE INTERRUPT command to the specific device to utilize the interrupt feature.

Note: The DMA and CTC vectors on the application processors and the DMA and one of the CTC vectors on the file processor are not available for use by applications since they perform part of the bus driver function.



Table 7-2
Fixed Interrupt Vectors for the File Processor

Address	Vector
F80C	PIO Channel A
F80E	PIO Channel B
F810	SIO Vector 0
F812	SIO Vector 1
F814	SIO Vector 2
F816	SIO Vector 3
F818	SIO Vector 4
F81A	SIO Vector 5
F81C	SIO Vector 6
F81E	SIO Vector 7
F820	CTC A, Channel A
F822	CTC A, Channel B
F824	CTC A, Channel C
F826	CTC A, Channel D
F828 - F82E	CT B (Do not use)
F830	DMA (Do not use)

Table 7-3
Fixed Interrupt Vectors for the Application Processor

Address	Vector
F80C	PIO Channel A
F80E	PIO Channel B
F810	DMA (Do not use)
F818 - F81E	CTC (Do not use)
F820	SIO Vector 0
F822	SIO Vector 1
F824	SIO Vector 2
F826	SIO Vector 3
F828	SIO Vector 4
F82A	SIO Vector 5
F82C	SIO Vector 6
F82E	SIO Vector 7

7.1.4 Boot Sequence

The boot sequence allows loading custom software without changing the system EPROM programs. This is accomplished by using a modular bootstrap-loading sequence.

The bootstrap-loading sequence for both the file processor and the application processor begins in the EPROM. After the processor is reset, or the system is turned on, the EPROM is physically mapped into all addressable memory space. The EPROM repeats at every 2K-byte boundary.

The EPROM copies its contents into RAM at location F800h, jumps to the next location relative to that address, disables the EPROM, and continues running in RAM.



Processor initialization is the next operation. All the programmable peripheral controllers on the processor board (SIO, CTC, etc.) are set up, and the parity RAM with the correct pattern is initialized. The bootstrap-load operation takes place after the processor initialization. The bootstrap-load operation differs in the file processor and the application processor.

The following description describes the bootstrap-load sequence for the file processor:

1. The EPROM sets the bus BUSY indicator. This indicator will prevent any application processor from attempting to boot before the file processor has completed its boot sequence. Following the BUSY indication, the processor initialization is complete.
2. The first sector of the disk is read into the file processor RAM. The first 128 bytes of this sector contains the post boot block. The post boot block is composed of:
 - FP post boot vector.
 - FP post boot routine.
 - AP post boot table.
 - AP entry table.
3. The file processor jumps to the FP post boot vector. This transfers control to the beginning of the FP post boot routine.
4. The FP post boot routine reads the file processor image into RAM at the proper address and transfers control to that address.
5. The n/STAR system initializes the request table and logs in all logical drives. When this is done, n/STAR clears the bus BUSY indicator and waits for application processor service requests.

The following description describes the bootstrap-load sequence for the application processor:

1. The application processor bootstrap operation does not involve disk I/O. After processor initialization, the bootstrap routine in the application processor EPROM performs a bus request to obtain the post boot block from the file processor. This operation does not occur until the bus BUSY indicator has cleared.
2. When the initial bus request is complete, another request is issued. This table contains the address of the application processor image in the file processor RAM. This table also contains the intended address where the image is to be placed.
3. Upon completion, the application processor jumps to the AP entry vector. This transfers control to the newly-loaded application processor image.

7.1.5 Disk Buffer Pooling

The buffered disk driver performs all hard disk I/O. This routine manages a buffer pool that eliminates redundant disk I/O. This greatly improves the performance of the system without detracting from the user's 64K memory space. The driver is also responsible for converting logical 128-byte sectors to physical sectors.



The Hub module makes disk requests to read or write logical 128-byte sectors. The buffered disk driver determines which physical sector contains the requested block and checks to determine whether that block is already in the buffer. If it is, the data is transferred to or from the buffer with no disk I/O.

If the sector is not in the buffer, a check is made to determine if there is an unused block available in the buffer. If there are no unused blocks, the contents of the least-used block is written to the disk. The requested sector is then read in from the disk and that block is marked as the most recently used.

If the requested operation is to write to an unused portion of the disk, the pre-read operation is not performed.

7.2 FILE AND RECORD LOCKING

The n/STAR Operating System allows three methods of locking records and files: automatic file locking, CP/M file sharing, and enhanced file sharing. Only enhanced file sharing requires special programming.

This section gives a description of these locking methods from a programming viewpoint. See Section 6.8 for a general description of file and record locking.

7.2.1 Automatic File Locking

Automatic file locking is the default file locking option. Automatic file locking allows a number of users to read from a file at the same time. The first user to write on a file will lock the file. A second user may read from the file in its locked state, but if this user attempts to write on the file, he will receive a FILE IN USE error message.

7.2.2 CP/M File Sharing

CP/M file sharing is provided for standard CP/M programs. CP/M file sharing is invoked by placing the file in Share Mode using the SET *ufn* \$SHR command.

This command sets F5 in the disk directory entry for the file name given. Subsequent reads to the file cause the record to be locked. The record is unlocked when the user does one of the following: writes to a record, reads another record, or closes the file.

Only use Share Mode for those files which are to be processed randomly. Do not use Share Mode for files that are processed sequentially. If you use Share Mode in indexed files, large portions of the file will be locked because an index record is locked when it is read.

7.2.3 Enhanced File Sharing

Enhanced file sharing allows the application program to control the locking and unlocking of records. To do this the user must open the file in Unlocked Mode. To open a file unlocked, the user must set F5 in the FCB prior to the OPEN command. Unlocked Mode allows multiple users to access the file at the same time. Once the file is in Unlocked Mode, it is the responsibility of the application program to control the locking and unlocking of records.

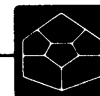

The program controls the locking and unlocking of records through the use of BDOS calls 42 and 43. Unlocked Mode is provided by BDOS function 42 Locked Mode is provided by BDOS function 43. These are described in Section 7.1.2

7.3 DRIVER INTERFACE GUIDE

This section provides detailed information on the application of custom operating system calls to the basic disk and bus driver EPROM calls.

7.3.1 Disk Drivers

Applications running in the file processor may access the EPROM-resident disk driver routines by simply loading register pair H-L with the address of a user- supplied request block and calling the vector at location F806h. Access to the diskette driver is provided using the same request block format by calling location F809h. These routines save the contents of registers B-C and D-E. The format of the request block for both disk and diskette drivers is shown in Table 7- 4.

Table 7-4 Request Block Format for Disk Drives and Diskette Drivers				
Name	Length	Function	Disk(F80H) Value	Diskette(F809H) Value
OPR	one byte	Disk OP code	(See below)	(See below)
CYL	two bytes	Cylinder address	0 - 554	0 - 76
TRK	one byte	Track (head)	0 - 2	0 - 1
SEC	one byte	Sector address	0 - 17	1 - 26
CNT	one byte	Sector count	1 - 255	(Not applicable)
BUF	two bytes	Buffer address	0 - FFFFh	0 - FFFFh

The disk (F8D6h) OP Codes are:

A8	Format disk and build defact map.
42	Write data.
52	Write data, retry on error.
43	Read data.
53	Read data, retry on error.
83	Sequence up and return.
82	Sequence up and wait for completion.
81	Sequence down and return.
AB	Initialize disk with pattern in buffer.
A3	Verify disk.

The disk (F809h) OP Codes are:

02	Read data, retry on error.
03	Write data, retry on error.

The disk error summary for the Supermicro 32 and the Supermicro 64 is listed in Table 7-5. The disk error summary for the Supermicro 8 is listed in Table 7-6. If you encounter a disk error while running the SYSINT utility, consult these lists.



**Table 7-5
Disk Error Summary*
Supermicro 32 and the Supermicro 64**

Error Bits:	Drive		Type		Code				Error Code	Definition	
	D7	D6	D5	D4	D3	D2	D1	D0			
	**		0	0	0	0	0	0	00	Successful completion	
			0	0	0	0	0	1	01	Motion retry	
			0	0	0	0	1	0	02	Data retry	
			0	1	0	0	0	1	11	CRC error	
			0	1	0	0	1	0	12	Drive seek fault	
			0	1	0	0	1	1	13	Drive Fault	
			0	1	0	1	0	1	15	Cylinder mismatch	
			0	1	0	1	1	0	16	Initiation complete	
			0	1	0	1	1	1	17	Stack error	
			0	1	1	0	0	0	18	Hardware trap	
			0	1	1	0	1	0	1A	RAM failure	
			0	1	1	0	1	1	1B	ID buffer failure	
			1	0	0	0	0	0	20	Driver not ready	
			1	0	0	0	0	1	21	Write protect	
			1	0	0	0	1	0	22	Drive not present	
			1	0	0	0	1	1	23	Sector size invalid	
			1	0	0	1	0	0	24	Alternate area overflow	
			1	1	0	0	0	0	30	Sector not found	
			1	1	0	0	0	1	31	Smart command reject	
			1	1	0	0	1	0	32	Drive busy time-out	
			1	1	0	0	1	1	33	Drive transfer time-out	
			1	1	0	1	0	0	34	Invalid cylinder/head	
			1	1	0	1	0	1	35	Invalid drive number	
			1	1	0	1	1	0	36	Invalid sector number	
			1	1	0	1	1	1	37	Command already in progress	
			1	1	1	0	0	0	38	Command double write	
			1	1	1	1	0	1	39	Drive command reject	
			1	1	1	0	1	0	A3	Multi-sector operation error	
* 0 = Successful Non-zero = Hard failure									** Bits D7 and D6		
									0	0	Drive 0
									0	1	Drive 1
									1	0	Drive 2
									1	1	Drive 3



Table 7-6 Disk Error Summary Supermicro 8										
Error Bits:	Drive		Type		Code				Error Code	Definition
	D7	D6	D5	D4	D3	D2	D1	D0		
	0	0	0	0	0	0	0	0	00	Successful completion
	0	0	0	0	0	0	0	1	01	Address mark not found
	0	0	0	0	0	0	1	0	02	Track zero error
	0	0	0	0	0	1	0	0	04	Aborted command
	0	0	0	1	0	0	0	0	10	ID not found
	0	0	1	0	0	0	0	0	20	CRC error—ID field
	0	1	0	0	0	0	0	0	40	CRC error—Data field
	1	0	0	0	0	0	0	0	80	Redirect error

For example, the assembler routine reading sector 4 from cylinder 10, head 1 on drive 0 would be:

```

DISK          EQU          OF806H
;
;READ:        LXI          H,RQBLK
              CALL         DISK
              JNZ          ERROR

;
RQBLK        DB           53H          ;READ SECTOR
              DB           0           ;DRIVE ZERO
              DW           10          ;CYLINDER 10
              DB           1           ;HEAD 1
              DB           4           ;SECTOR 4
              DB           1           ;READ 1 SECTOR
              DW           BUFFER

;
;BUFFER:      DS           1024

```

7.3.2 Bus Driver

The processor boards within the system communicate via a high-speed local network called the m/BUS Interprocessor Link. It employs the contention access protocol termed CSMA/CD (carrier sense multiple access with collision detection). This approach eliminates the overhead associated with other network architectures such as those based on a polling scheme.

Externally, the bus communication between processors appears as a simple DMA transfer to or from the target processor's RAM. The processor requesting a transfer may either "send" a buffer to any other processor on the bus, or it may request a buffer from any other processor.



Bus transactions are performed by calling the EPROM bus driver routine at location F803h. Registers H-L contain the address of a user-supplied request block. The address format for register H-L is shown in Table 7-7.

Table 7-7			
Address Format for Register H-L			
Name	Length	Function	Value
OPR	one byte	Operation: 0 = send, 1 = receive	0000h-00FFh
UAD	one byte	Target unit address	0000h-FFFFh
SRC	two bytes	Source buffer address	0000h-FFFFh
DST	two bytes	Destination buffer address	0000h-FFFFh
LEN	two bytes	Buffer length	0002h-0800h

The operation code is always either 1 or 0. Operation 1 is "receive" and transfers the specified buffer from the source address in the target processor's RAM to the destination address in the requesting processor's RAM.

Operation 0 is "send" and transfers the specified buffer from the source address in the requesting processor's RAM to the destination address in the target processor's RAM.

Due to timing requirements, the maximum buffer size is 2048 bytes. DMA chip restrictions limit the minimum buffer size to two bytes.

The unit address is a single byte representing the unit address number of the target processor. The file processor is always unit 255 (FFh). An application processor may be any other unit number. Specific application processor unit addresses may be determined by observing the "INITIALIZING . . ." message containing the unit number of power-up.

The unit address for any processor is stored in that processor's RAM at location F802h and may be referenced by the application program. The RAM location F802h, however, must not be changed.

The source, destination, and length are absolute values corresponding to the addresses of the buffers and their length (in bytes) respectively.

An example of an assembler routine call to the bus driver to retrieve the post boot block from the file processor is shown below:

```

MBXFR      EQU      F803H
;
BOOT:      LXI      H,RQBLK
           CALL    MBXFR
           JNZ     ERROR
;
RQBLK     DB      1           ;RECEIVE POST-BOOT BLOCK
           DB      OFFH      ;FROM FP
           DW      0         ;FROM 0000H in FP
           DW      0         ;TO 0000H IN OUR RAM
           DW      128       ;128 BYTES

```



When the bus driver routine returns, register A contains zero. The zero flag is set if the operation was successful. Otherwise a non-zero condition indicates that the target processor did not respond to the call. A non-zero return usually means the target unit address does not exist in the system.

7.4 HARDWARE I/O PORT ASSIGNMENTS

This section lists and describes the hardware I/O devices available on the file processor and application processors.

For detailed information on the programming of specific Z80A peripheral devices refer to the appropriate Z80A technical manual.

The devices available on the Z80A version of the file processor board are:

- One CTC for applications use.
- One CTC for baud rate and interrupt control.
- one SIO for serial interface ports.
- One PIO for bus interface.
- One DMA for bus transfers.

The devices available for other versions of the file processor board are:

- WD1793 Diskette Controller
- Bidirectional TTL Parallel Port (16-bit)
- TTL Hard Disk Interface

The devices available on the Z80A version of the application processor board are:

- One CTC for baud rate and interrupt control.
- One SIO for console and printer ports.
- One PIO for bus interface.
- One DMA for bus transfers.

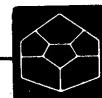

**Table 7-8
File Processor Port Assignments**

Port	Name	Function
00	DMA	DMA control channel
10	CTC-0	(Spare)
11	CTC-1	(Spare)
12	CTC-2	(Spare)
13	CTC-3	(Spare)
20	CTC-0	Serial A clock
21	CTC-1	Serial B clock
22	CTC-2	Parity error interrupt
23	CTC-3	Bus interrupt
40	SIOAD	Serial A data channel
41	SIOAC	Serial A control channel
42	SIOBD	Serial B data channel
43	SIOBC	Serial B control channel
50	PIOAD	Parallel A data
51	PIOAC	Parallel A control
52	PIOBD	Parallel B data
53	PIOBC	Parallel B control
60	FDSTAT	Diskette control register
61	FCYLDR	Diskette cylinder register
62	FSECTP	Diskette sector register
63	FDDATA	Diskette data register
70	PLOW	Lower parallel I/O
71	PHI	Upper parallel I/O
80	DSTAT	Hard disk status/command
81	DDATA	Hard disk data
82	R/P0	Result/parameter register 0
83	R/P1	Result/parameter register 1
84	R/P2	Result/parameter register 2
85	R/P3	Result/parameter register 3
86	R/P4	Result/parameter register 4
87	R/P5	Result/parameter register 5

**Table 7-9
Application Processor Port Assignments**

Port	Name	Function
00	PIOAD	Parallel A data
01	PIOAC	Parallel A control
02	PIOBD	Parallel B data
03	PIOBC	Parallel B control
20	DMA	DMA control channel
30	CTC-0	Serial A clock
31	CTC-1	Serial B clock
32	CTC-2	Parity error interrupt
33	CTC-3	Bus interrupt
60	SIOAD	Serial A data channel
61	SIOAC	Serial A control channel
62	SIOBD	Serial B data channel
63	SIOBC	Serial B control channel



SPECIFICATIONS

APPENDIX A

GENERAL

Physical Dimensions

Length	33.0 (83.8 cm)
Width	12.0 in (30.5 cm)
Height	24.0 in (61.0 cm)
Weight	150 lbs (68.2 kg) - Supermicro 8 155 lbs (70.5 kg) - Supermicro 32 125 lbs (57.7 kg) - Supermicro 32X 140 lbs (63.5 kg) - Supermicro 64X

Environmental

Ambient Temp.	10° to 30° C (50° to 86° F)
Humidity	10 to 90%

Power Requirements

Power Consumption	120 VAC/60 Hz (240 VAC/50 Hz)
One User	105W - Supermicro 8 344W - Supermicro 32 160W - Supermicro 32X 236W - Supermicro 64X
8 Users	227W - Supermicro 8
32 Users	360W - Supermicro 32
32 Users	530W - Supermicro 32X
64 Users	1126W - Supermicro 64X

FILE PROCESSOR

	Standard Supermicro	Supermicro X
CPU		
Type	Z80A	Z80B
Primary Clock	4 MHz	6MHz

RAM

Cycle Time	200ns Dynamic	150ns Dynamic
Capacity	65,536 bytes	262,144 bytes
Parity Checking	Yes	Yes



	Standard Supermicro	Supermicro X
ROM		
Capacity	2048 bytes	4096 bytes
expandable to		8192 bytes
Software Deselect	Yes	Yes
Interrupts	Vectored, priority	Vectored, priority
I/O		
Serial	2 Channel RS-232 Z80A DART SIO	2Channel RS-232 Z80B SIO
Parallel Bus	Z80A PIO (8-bit, bi-directional)	Z80B PIO (8-bit, bi-directional)
DMA	Z80A DMA	Z80B DMA
Timer	Two Z80A CTC	Z80B CTC (4-Channel)
Floppy Disk	WD 1793 single/dual density	WD 1793 single/dual density
Timer	Two Z80A CTC	Z80B CTC (4-Channel)
DC Power Requirements		
	+5V@ 2.0A	+5V @ 4.0A
	+/-12V @ 0.03A	+/-12V @ 0.04A

APPLICATION PROCESSORS - 80 SERIES

	Standard Supermicro	Supermicro X
CPU		
Type	Z80A	Z80A
Primary Clock	4MHz	4MHz
RAM		
Cycle Time	200ns Dynamic	200ns Dynamic
Capacity	65,536 bytes	65,536 bytes
Parity Checking	Yes	Yes
ROM		
Capacity	2048 bytes	4096 bytes
expandable to		8192 bytes
Software Deselect	Yes	Yes
Interrupts	Limited	Vectored, priority

022583



	Standard Supermicro	Supermicro X
I/O		
Serial	2-channel RS-232 Z80A SIO	2-channel RS232 Z80A SIO
Parallel Bus	Z80 PIO	Z80A PIO
Timer	Two Z80A CTC	Z80A CTC (4-Channel)
DC Power Requirements		+5V @ 1.2A +/-12V @ 0.04A

APPLICATION PROCESSORS - 86 SERIES

CPU

Type	Intel 8086
Primary Clock	8 MHz
Math Processor Option	Intel 8087 (8MHz only)
DMA Option	Intel 8089 (8MHz only)

RAM

Cycle Time	750 ns Dynamic
Capacity	262,144 bytes/card (256K)
Number of Cards	Up to three per AP/86

Card Slots Each 86-Series AP uses two, three, or four m/BUS slots, depending upon memory capacity.

I/O Parallel to the m/BUS only.

DISK DRIVES - SUPERMICRO 8

	Hard Disk Drive	Diskette Drive
Maximum Number of Disk Drives	Three	One
Capacity Per Drive (Formatted) - MICRO 10-8		
Capacity	10.0 megabytes	0.512 megabytes
Bytes per Sector	256	256
Sectors per Track	32	26
Number of Cylinders	306	77
Number of Heads	4	1



Capacity Per Drive (Formatted) - MICRO 15-8

Capacity	15.0 megabytes	0.512 megabytes
Bytes per Sector	256	256
Sectors per Track	32	26
Number of Cylinders	306	77
Number of Heads	6	1

Timing

Single Track Positioning	2 ms	3 ms
Average Track Positioning	80 ms	91 ms
Rotational Latency	8.3 ms	83 ms
Transfer Rate	5 megabits/sec	500K bits/sec
Formatting Options		Single-sided, single-density

DISK DRIVE - SUPERMICRO 32

	Hard Disk Drive	Diskette Drive
Maximum Number of Drives per System	Four	One

Capacity Per Drive (Formatted)

Capacity	32.3 megabytes	0.512 megabytes
Bytes per Sector	1024	256
Sectors per Track	12	26
Number of Cylinders	525	77
Number of Heads	5	1

Timing

Single Track Positioning	8 ms	3 ms
Average Track Positioning	45 ms	91 ms
Rotational Latency	8.3 ms	83 ms
Transfer Rate	6.4 megabits/sec	500K bits/sec
Formatting Options		Single-sided, single-density Single-sided, double-density

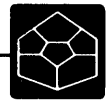

DISK DRIVE - SUPERMICRO 32X

	Hard Disk Drive	Diskette Drive
Maximum Number of Drives per System	Four	One
Capacity Per Drive (Formatted)		
Capacity	60 megabytes	0.512 megabytes
Bytes per Sector	1024	128/256
Sectors per Track	12	26
Number of Cylinders	1049	77
Number of Heads	5	1
Timing		
Single Track Positioning	8 ms	3 ms
Average Track Positioning	42 ms	91 ms
Rotational Latency	8.3 ms	83 ms
Transfer Rate	6.4 megabits/sec	500K bits/sec
Formatting Options		Single-sided, single-density Single-sided, double-density

DISK DRIVES - SUPERMICRO 64

	Hard Disk Drive	Diskette Drive
Maximum Number of Drives per System	Two	One
Capacity Per Drive (Formatted)		
Capacity	60.5/141.2 megabytes	0.512 megabytes
Bytes per Sector	1024	256
Sectors per Track	12	26
Number of Cylinders	1087	77
Number of Heads	5	1

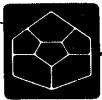

Timing

Single Track Positioning	8 ms	3 ms
Average Track Positioning	45 ms	91 ms
Rotational Latency	8.3 ms	83 ms
Transfer Rate	6.4 megabits/sec	500K bits/sec
Formatting Options		Single-sided, single-density Single-sided, double-density

DISK DRIVES - SUPERMICRO 64X

	Hard Disk Drive	Diskette Drive
Maximum Number of Drives per System	Two	One
Capacity Per Drive (Formatted)		
Capacity	136 megabytes	0.512 megabytes
Bytes per Sector	1024	256
Sectors per Track	12	26
Number of Cylinders	1087	77
Number of Heads	7	1
Timing		
Single Track Positioning	8 ms	3 ms
Average Track Positioning	40 ms	91 ms
Rotational Latency	9.7 ms	83 ms
Transfer Rate	8.32 megabits/sec	500K bits/sec
Formatting Options		Single-sided, single-density Single-sided, double-density



FILES ON THE DISTRIBUTION DISKETTES APPENDIX B

Version 2.49 of the n/STAR Operating System is supplied on three diskettes containing the following files. Note that under the heading n/STAR, a number indicates the CP/M User Number under which the specified file is located.

FILE NAME	DISKETTE			DESCRIPTION
	n/STAR	CP/M	DIAG	
ASM.COM		X		DRI assembler
ASSIGN.COM	1			user profile maintenance utility
D.COM	1			directory display program
DBIOS.HEX			X	standard diskette BIOS
DBIOS3.HEX	0	X	X	SM64 diskette BIOS
DBIOS4.HEX	0	X	X	universal diskette BIOS
DBIOSN1.HEX	0	X	X	SM8 diskette BIOS
DBIOSN2.HEX	0	X	X	SM32 diskette BIOS
DBOOT.HEX			X	standard diskette BIOS
DESPPOOL.COM	1			system despooler
DEVICES.COM	1			list created devices program
DDT.COM		X		DRI interactive debugger
DISKTEST.COM			X	
DKM.COM			X	diskette maintenance utility
DOWN.COM	1		X	power off command
DSD.COM			X	m/BUS diagnostic
DSDPATCH.AMS			X	DSD terminal patch code
DSDTERM.COM			X	DSD terminal configurator
DUMP.ASM		X		DRI file display utility
DUMP.COM		X		DRI file display utility
ED.COM		X		DRI editor
GENSTAR.COM	0			n/STAR installation program
GENSTAR.SUB	0			n/STAR installation control file
GENSYSF.COM	0			generate .SYS files on MAINT volume
GPON.COM	1		X	FP/AP debug monitor
IMAGE.COM			X	diskette copying utility
INSTALL.SUB	0			system installation program
LIST.COM	1			n/STAR list utility
LOAD.COM		X		DRI object file editor
LOGOFF.COM	1			user signoff program
LOGON.COM	1			user signon program
MAINT.COM	1			n/STAR system maintenance utility
MEGGASE.SYS	0			logged off screen text file
MOVCPM.COM		X		DRI CP/M relocation program
NEWCON.COM	1			Z80 TLink adaptor



NSTAR86.SYS	1			n/STAR-86 system image
PIP.COM	0,1	X	X	DRI file copy utility
POSTBOOT.COM	0	X	X	diskette post boot processor
PRTLOG.BAS			X	system log source code
PRTLOG.COM	1			system log program
QMAINT.COM	1			queue maintenance utility
RESET.COM	1			AP reset program
SELDRIVE.COM			X	select drive for backup
SET.COM	1			set file attribute program
SETBAUD.COM	1			temp. change AP baud rates
STAT.COM		X	X	DRI system status utility
SUBMIT.COM	0	X	X	DRI batch execution utility
SYSGEN.COM		X	X	copy system tracks of diskettes
SYSINT.COM	0		X	initialize the system drive
TAPE*.OVL			X	overlays for the tape backup utility
TAPE.COM			X	tape backup utility
TAPEDISK.DAT			X	drive specification text file for TAPE.COM
TEST.COM			X	
TEST1.COM			X	
TEST2.COM			X	
TLINK.COM	1			terminal link program
TOD.COM	1			date/time program
WHO.COM	1			list APs and system Users
XSUB.COM	1	X		extensions to the SUBMIT utility

Files on the n/STAR Distribution Diskette are located under various CP/M User numbers; therefore, typing DIR will not list all files shown.

NOTE

Digital Research Incorporated (DRI) supplies several useful utilities on the CP/M Distribution Diskette. Since these utilities are property of DRI, Molecular cannot include them as part of n/STAR. However, you can copy any or all of the utilities onto your hard disk after installing your system. The CP/M utilities are:

ASM.COM	DRI assembler
DDT.COM	DRI interactive debugger
DUMP.COM	DRI file display utility
DUMP.ASM	DRI file display source code
ED.COM	DRI editor
LOAD.COM	DRI object file editor
MOVCPM.COM	DRI CP/M relocation program
STAT.COM	DRI system status utility
SUBMIT.COM	DRI batch execution utility

022583



VOLUME IDENTIFICATION CHART

APPENDIX C

Use this chart for a schematic representation of volume assignments. Enter in each box the name and passwords for each volume. This chart is particularly useful when setting up the n/STAR Security System for first time. See Section 6.9 for a description of installing the n/STAR Security System.

LOGICAL DRIVE

	A	B				
USER 0						
1						
2						
3						
4						
5						
6						
7						
8						
9						
10						
11						
12						
13						
14						
15						

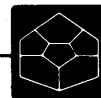

n/STAR ERROR MESSAGES

APPENDIX D

BDOS error messages are displayed in the following format:

```
BDOS ERROR ON dmessage  
FUNCTION nnn    FILE: filename.typ
```

where

<i>d</i>	indicates the drive.
<i>message</i>	indicates the error message.
<i>nnn</i>	indicates the number of the BDOS function involved.
<i>filename.typ</i>	indicates the file.

n/STAR has the following error messages:

MSM DID NOT RESPOND

The file processor did not respond to an m/BUS request. This usually indicates that the file processor has gone down. Call your Service Representative.

BDOS ERROR ON *d*: BAD SECTOR

This error occurs when there is a hardware error on the diskette. It may occur (1) if you try to read a diskette of one density in a drive that is set for a different density, (2) if the diskette is improperly inserted, or (3) if there is no diskette in the drive. Entering CTRL-C will reboot the application processor, any key will cause the system to ignore the error.

BDOS ERROR ON *d*: SELECT

An unassigned drive has been selected.

BDOS ERROR ON *d*: FILE R/O

An attempt was made to modify a file that was set to read only.

BDOS ERROR ON *d*: DRIVE IN USE

An attempt was made to access the diskette drive while it was in use. If the diskette drive appears to be available but the error still occurs, the drive is assigned to the last user. Reboot the application processor that last used the diskette drive by pressing CTRL-C or BREAK.

BDOS ERROR ON *d*: FILE IN USE

An attempt was made to modify a file that was opened in lock mode by another user.



BDOS ERROR: SYSTEM PRINTER IN USE

An attempt was made to access the system printer while it was being used by another user.

BDOS ERROR: DISK ERROR ON SPOOLER OPERATION

This message usually means the spooling operation encountered a directory or disk-full condition. All or part of the spool file may be lost.

BDOS ERROR ON *d*: LOCK TABLE FULL

An entry is made in the lock table for each opened file and locked record. This error occurs when the lock table overflows. The lock table has room for over 200 entries which is enough for normal use. If the table becomes full, at least one application program is not closing its input files.

BDOS ERROR ON *d*: INTERNAL ERROR

If this error message appears on the screen, call your Service Representative.

ILLEGAL BIOS CALL

A program has attempted to perform a direct BIOS call which is not supported by the system.

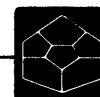

PRINTER INTERFACE CABLES

APPENDIX E

This appendix contains specific cabling recommendations for printers we have used or otherwise made to work with the Supermicro computer. A diagram such as the following is given for each printer.

PRINTER		COMPUTER
2	---	2
3	---	3
4/5		
7	---	7

The numbers refer to the RS232 connector pins at the printer and computer ends of the cable. The symbol "---" means the pins are connected via the cable. The designation "4/5" means that pin 4 is jumpered to pin 5 on the same connector. (In the example above, this is the printer connector). Where appropriate, additional printer information is provided, such as recommended baud rates and application software notes.

We intend to update the information in this appendix as we learn details about other printers. We welcome any relevant information you may have about printers that are not documented here.

PRINTER: DIABLO 630

Cable:	Printer		Computer
	2	---	2
	3	---	3
	4/5/6		
	7	---	7
	20	---	20

Additional Information: There is an 8-bit switch inside the printer that must be set correctly (see the manufacturer's manual). We recommend that you set switches 1-6 down and switches 7-8 up. Also, set the speed switch on the front of the printer to "H" (high), and run at 1200 baud.

PRINTER: TEXAS INSTRUMENTS 810

Cable:	PRINTER		COMPUTER
	2	---	2
	3	---	3
	6/8/9		
	7	---	7
	11	---	4/19/20



PRINTER: NEC SPINWRITER 5525

Cable:	Printer		Computer
	2	---	2
	3	---	3
	5/6/8/20		
	7	---	7
	11	---	20

Additional Information: There is an 8-bit switch inside the printer that must be set correctly (see manufacturer's manual). We recommend that you set switches 1-6 down and switches 7-8 up. Also, set the speed switch on the front of the printer to "H" (high), and run at 1200 baud.

PRINTER: QUANTEX 7030

Cable:	Printer		Computer
	2	---	2
		---	3
	4/5		
	6/8		
	7	---	7
	20	---	20

Additional Information: Operate the printer with the XON/XOFF protocol and run at 9600 baud.

PRINTER: OKIDATA MODELS 82, 83, 84 (with 2K buffer)

PRINTER		COMPUTER
3	---	3
7	---	7
11	---	20
4/5		
6/20		



A

- AC power
 - connecting, 2-11
- AC power consumption, 2-2
- AC power isolation requirements, 2-3
- AP, *see* application processor
- AP/86, 1-5, 1-9
 - location, 1-5
 - memory, 1-5
- application processor, 1-1, 1-2
 - 16-bit, 1-1, 1-5, 1-9
 - AP8601, 1-9
 - location, 1-5
 - memory, 1-5, 1-9
 - MM 8256-2, 1-9
 - MM 8256-3, 1-9
 - MM 8256-4, 1-9
 - ROM options, 1-9
 - 80 Series, 1-9
 - 86 Series, 1-9
 - AP 8001, 1-9
 - AP 8003, 1-9
 - AP 8011, 1-9
 - boot image, 7-1
 - bootstrap-loading procedure, 7-8
 - connecting external devices, 2-8
 - despooling, 6-22
 - initial command, 6-22
 - location, 1-2
 - memory, 1-2
 - parallel port, 1-2
 - port assignments, 7-15
 - printer connections, 2-10
 - request table, 7-1
 - resetting, 3-12
 - RS232C serial port, 1-2, 1-10, 2-8
 - setting the printer baud rate, 6-21
 - setting the terminal baud rate, 6-21
 - terminal connections, 2-9
- ASSIGN, 6-5, 6-10, 6-11
- assigning a printer, 6-12, 6-16
- assigning volumes, 6-4, 6-12, 6-15
- Attach List function, 7-5
- attaching terminals, 1-10
- automatic file locking, 7-9

B

- backing up the disk, 5-4
- backup
 - copying diskettes, 3-7, 3-8
 - diagnostic mode, 3-8
 - multi-user mode, 3-7
 - copying system diskettes, 3-6
 - data, 3-6
 - diskette, 3-6

- Distribution Diskette, 3-10
- importance of, 3-5
- tape, 3-6
- two-tier, 3-6
- baud rate
 - printer
 - setting, 6-21
 - terminal
 - setting, 6-21
- boot sequence, 7-7
- bootstrap-loading sequence, 7-7
- buffered disk driver, 7-1
- bus driver, 7-12

C

- commands
 - ASSIGN, 6-5, 6-10, 6-11
 - CTRL-P, 6-9
 - CTRL-X, 6-25
 - D, 6-23
 - DIR, 3-12
 - DOWN, 3-5, 3-14, 6-23
 - ENABLE INTERRUPT, 7-6
 - ERA, 3-8, 3-9
 - LIST, 6-29
 - LIST SPOOL, 6-30
 - LOGOFF, 6-10, 6-11
 - LOGON, 6-10
 - MAINT, 6-5, 6-10, 6-13
 - PIP, 3-7, 3-9, 3-10, 3-12
 - QMAINT, 6-23, 6-30
 - SAVE, 3-13
 - SET, 6-7, 6-25
 - SETBAUD, 6-26
 - STAT, 6-7
 - SUBMIT, 6-27
 - TOD, 6-27
- Conditional Attach List Function, 7-6
- configuring the disk table, 4-8
- connecting AC power, 2-11
- copying diskettes, 3-7, 3-8
 - diagnostic mode, 3-8
 - multi-user mode, 3-7
- copying system diskettes, 3-6
- CP/M, 1-1, 1-6, 4-1, 6-1
 - file sharing, 6-32, 7-9
 - User Number, 4-1, 6-2
 - changing, 6-17
- CP/M-86, 1-6
- CPU, 1-1
- CTRL-X, 6-25
- CTRL-P, 6-9



D

- D, 6-23
- data storage
 - off line, 1-4
- deleting a volume, 6-17
- despooling, 6-29
- despooling printer, 6-29
- diagnostic mode, 1-4, 1-6, 2-9, 3-1, 4-1
 - logical drives, 4-1
 - power on procedure, 3-4
 - system drives, 4-1
- diagnostic utilities, 1-6
 - DKM, 1-7, 4-3
 - DSD, 1-7
 - GENSTAR, 1-7, 4-11
 - GPMON, 1-7
 - SYSINT, 1-7, 4-4
 - tape backup, 5-4
- diagnostics, 4-1
- DIR, 3-12
- Directory Search Default, 6-7, 6-34
- directory utility, 6-23
- disk buffer pool, 1-2, 7-1, 7-8
- disk drive, 1-1, 1-3, 3-1
 - locking, 2-7
 - unlocking, 2-6
- disk drivers, 7-10
 - request block format, 7-10
- disk error summary, 7-11
- diskette
 - formatting, 4-3
 - handling, 3-1, 3-2
 - inserting, 3-1, 3-2
 - precautions, 3-2
 - verifying, 4-3
- diskette access, 6-27
- diskette controller, 1-2
- diskette drive, 1-1, 1-3, 1-4, 3-1, 6-1
 - releasing, 6-28
- Distribution Diskette, 1-4
 - write enable caution, 3-10
- DKM, 1-7, 4-3
- DOWN, 3-5, 3-14, 6-23
- DOWN.COM, 3-5
- driver interface, 7-10
- DSD, 1-7

E

- ENABLE INTERRUPT, 7-6
- enhanced file sharing, 6-23
- environmental requirements, 2-3
- EPROM, 7-7
- ERA, 3-8, 3-9
- error codes
 - tape, 5-10

- event log, 6-19
 - configuration, 6-18
 - file, 6-19
 - maximum records, 6-18
 - switch, 6-18
- event log, sample, 6-8
- event logging, 6-8
 - sample program, 6-9

F

- file attributes
 - setting, 6-25
- File Control Block, 7-2
- file lock table, 6-7
- file locking, 6-31, 7-9
 - automatic, 6-31, 7-9
- file processor, 1-1, 1-2
 - address, 6-17
 - bootstrap-loading procedure, 7-8
 - location, 1-2
 - memory, 1-2
 - parallel port, 1-2
 - port assignments, 7-15
 - printer connections, 2-10
 - resetting, 3-13
 - resetting caution, 3-13
 - RS232C serial port, 1-2, 1-10
 - terminal connections, 2-9
- file sharing
 - enhanced, 6-33, 7-9
- FP, see file processor

G

- GENSTAR, 1-7, 4-11
- Get Date and Time function, 7-4
- Get List Number function, 7-6
- GPMON, 1-7

H

- hard disk
 - configuring, 4-4, 4-8
 - configuring the disk table, 4-8
 - Supermicro 32, 4-5
 - Supermicro 64, 4-5
 - Supermicro 8, 4-6
 - verifying, 4-4
 - Supermicro 32, 4-7
 - Supermicro 64, 4-7
 - Supermicro 8, 4-7
- hard disk drive, 1-1, 1-3, 1-6, 3-1
 - locking, 2-7
 - unlocking, 2-6, 2-11

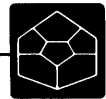

hardware I/O port assignments, 7-14
Hardware Maintenance Manual, Supermicro Series, 1-1
HISTORY.SYS file, 6-8, 6-19
hub module, 7-1

I

I/O port assignments, hardware, 7-14
initial command, 6-13, 6-16
 system, 6-21
 system despooler, 6-22
initial commands, 6-10

L

LIST SPOOL, 6-30
listing tape directory, 5-8
loading disk from tape, 5-6
loading EPROM contents, 7-1
local printer, 6-12, 6-16, 6-28
Lock Record function, 7-2
logged-off screen, 6-10
logging, system event, 6-8
logical drive
 changing, 6-17
logical drives, 4-1, 6-1, 6-3
 dividing into volumes, 6-2
 first, 4-1
 second, 4-1
LOGOFF, 6-10, 6-11
LOGON, 6-10
logged-off screen
 changing, 6-35

M

m/BUS, 1-1, 1-9
 AP-AP communication, 1-3
 AP-AP/86 communication, 1-5
 AP-FP communication, 1-3
 Carrier Sense Multiple Access
 with Collision Detection, 1-3, 7-12
 interprocessor link, 1-2, 7-12
MAINT, 6-5, 6-10, 6-13
 menu, 6-14
MAINT volume, 6-8
Maintenance Manual, Supermicro Series, 1-1
maintenance user, 6-6
memory
 dedicated, 1-1
memory layout, 7-1
MICRO O-OT, 1-8
MICRO 10-8, 1-7
MICRO 10-D, 1-7

MICRO 20-T, 1-7
MICRO 35-32, 1-8
MICRO 35-32 NT, 1-8
MICRO 35-D1, 1-8
MICRO 35-D2, 1-8
MICRO 68-0A, 1-8
MICRO 68-32, 1-8
MICRO 68-32A, 1-8
models and options, 1-7
multi-user mode, 1-6, 2-9, 3-2
 power on procedure, 3-3

N

n/STAR, 1-1, 1-2, 1-6, 3-1
 all terminals locked-out, 6-35
 data security system, 6-1
 tutorial, 6-2
 disk organization, 6-1
 diskette access, 6-27
 diskette density, 6-27
 enhancements
 BDOS, 6-1
 CBIOS, 6-1
 enhancements to CP/M, 1-6
 file lock table, 6-7
 fixed interrupt vectors, 7-6
 introduction, 6-1
 loading onto hard disk, 4-11
 logical drives, 6-1, 6-3
 dividing into volumes, 6-2
 maintenance user, 6-6
 operation, 1-6
 print spooling, 6-1
 security system
 commands, 6-10
 shared peripherals, 6-1
 single terminal lock-out, 6-35
 system configuration, 6-20
 system interface, 7-1
 upgrading to 2.244, 4-9
 User Drives, 6-6
 User ID, 6-4
 User Profile screen, 6-4
 Version 2.244, 6-1
 Volume Profile screen, 6-4
 volume read password, 6-4
 volumes, 6-2
 assigning to User IDs, 6-4
 defining, 6-4
n/STAR defaults, 2-9
n/STAR interrupt vectors, 7-6

O

operating system, 1-1, 1-2, 1-6



P

password
 system, 6-10
 changing, 6-14
 User, 6-11
 changing, 6-12, 6-15
 volume read, 6-4
 changing, 6-17
 volume write
 changing, 6-17
performance accelerator,
see application processor, 16-bit
peripherals
 shared, 1-1
PIP, 3-7, 3-9, 3-10, 3-12
PIP.COM, 3-7, 3-9
post boot block, 7-1
power down instructions, 3-5
print spooling, 6-1
printer, 1-10
 assigning, 6-12, 6-16
 baud rate, 2-10
 configuration, 2-10
 connections, 2-10
 despooling, 6-29
 interface cable wiring, 2-10
 local, 1-10, 2-11, 6-12, 6-16, 6-28
 operation, 6-28
 spooling, 1-10, 2-11, 6-12, 6-16, 6-29
 system, 1-10, 2-11, 6-12, 6-16, 6-29
printing User Profile Directories, 6-19
printing Volume Profile Directories, 6-19
processor initialization, 7-8

Q

QMAINT, 6-23, 6-30
queue
 BOTTOM, 6-25
 CANCEL, 6-25
 CTRL-X, 6-25
 DOWN, 6-25
 HOLD, 6-23
 modifying, 6-24
 RELEASE, 6-23
 TOP, 6-25
 UP, 6-25
queue activity report, 6-23
Queue Maintenance Screen, 6-24

R

RAM, 1-2
record locking, 6-31, 7-9

reset, 3-12
 application processor, 3-12
 file processor, 3-13
 caution, 3-13
 procedures, 3-12
 system, 3-14
resetting the system, 2-11
restoring disk files from tape, 5-6
retensioning tape cartridge, 5-9

S

SAVE, 3-13
secured mode, volumes, 6-6
secured volumes, 6-17
security system, 6-13
 commands, 6-10
 first time use, 6-33
 getting to know, 6-33
 logging on, 6-10
 operation without, 6-31
 recovery, 6-35
 tutorial, 6-2
SET, 6-7, 6-25
 archive attribute, 6-26
 parital close attribute, 6-25
 read-only attribute, 6-25
 shared attribute, 6-25
 system attribute, 6-26
Set BDOS Error Mode function, 7-3
Set Date and Time function, 7-4
Set List function, 7-5
SETBAUD, 6-26
shared files, 1-6
shared peripherals, 1-1, 1-6, 6-1
single-user configuration, 4-1
single-user mode, *see* diagnostic mode
site preparation, 2-1
16-bit application processor, 1-1, 1-5
software, Supermicro, 1-6
spooling, 6-30
spooling printer, 6-12, 6-16, 6-29
STAT, 6-7
SUBMIT, 6-27
Supermicro
 cable routing, 2-1, 2-3
 clearance required, 2-1
 final preparation for use, 2-11
 installation location, 2-1
 power requirements, 2-2
 preparation for use, 2-4
 setup, 2-4
 space required, 2-1
 unpacking, 2-3
Supermicro 32, 1-8
 disk expansion unit, 1-8



- diskette drive, 1-8
- tape backup unit, 1-8
- Supermicro 64, 1-8
 - disk expansion unit, 1-8
 - diskette drive, 1-8
 - stand-alone tape unit, 2-1
 - tape backup unit, 1-8
- Supermicro 8, 1-7
 - disk expansion unit, 1-7
 - diskette drive, 1-7
 - tape backup unit, 1-7
- Supermicro Distribution Diskette, 1-4
- Supermicro Maintenance Manual, 1-1
- Supermicro software, 1-6
- \$SYS flag, 3-7, 6-7, 6-34
- SYSGEN, 3-10
- SYSINT, 1-7, 4-4
- system checkout, 2-11
- system configuration, 6-20
- system event logging, 6-8
- system interface, 7-1
- system password, 6-10
 - changing, 6-14
- system printer, 6-12, 6-16, 6-29
 - attaching, 6-29
- system prompt, 4-1
- system reset, 3-14

T

- tape backup, 1-4, 5-1
 - directory listing, 5-8
 - disk files, 5-4
 - error codes, 5-10
 - program, 5-3
 - purpose, 5-1
 - restoring disk files, 5-6
 - retensioning the cartridge, 5-9
 - tutorial, 5-3
- tape backup software, 1-4
- tape backup unit
 - operation, 5-1
- tape backup utilities, 1-6
- tape cartridge
 - handling, 5-1
 - inserting, 5-2
 - precautions, 5-2
 - retensioning, 5-9
- tape drive, 1-1, 1-4
 - location, 1-5
 - operation, 5-1
- tape error codes, 5-10
- tape utility, 5-4
- terminal
 - baud rate, 2-9
 - configuration, 2-9
 - connections, 2-9
 - interface cable wiring, 2-9

- terminal lock-out, 6-35
- time of day command, 6-27
- TOD, 6-27
- turning off the power, 3-5

U

- Unlock Record function, 7-2
- Unlocked Mode, 7-9
- unsecured mode, volumes, 6-6
- unsecured volumes, 6-17
- User Drives, 6-6
- User ID, 6-4, 6-10
- user maintenance, 6-15
- User Number
 - changing, 6-17
- User Password, 6-11
 - changing, 6-12, 6-15
- User Profile, 6-10
- User Profile Directory
 - printing, 6-19
- User Profile screen, 6-4, 6-12, 6-15
- USERSYS volume, 6-34

V

- volume
 - deleting, 6-17
- volume maintenance, 6-16
- volume passwords
 - assigning, 6-6
- Volume Profile, 6-10
 - updating, 6-17
- Volume Profile Directory
 - printing, 6-19
- Volume Profile screen, 6-4
- volume read password, 6-4
 - changing, 6-17
- volume write password
 - changing, 6-17
- volume-read password, 6-6
- volume-write password, 6-6
- volumes, 6-2
 - already on disk, 6-33
 - assigning, 6-4, 6-12, 6-15, 6-34
 - assigning to more than one user, 6-5
 - defining, 6-4, 6-34
 - included with system, 6-33
 - maintenance, 6-16
 - passwords, 6-6
 - secured, 6-6, 6-17
 - unsecured, 6-6, 6-17
 - USERSYS, 3-7

Z

- Z80A, 1-1, 1-2



molecular™
computer

The Supermicro Company®

251 River Oaks Parkway • San Jose, CA 95134 • 408/262-2122.

SUPERMICRO INSTALLATION AND USER REFERENCE MANUAL

CHANGE NOTICE #1

This change notice updates your Supermicro Installation and User Reference Manual to describe the current revision of the n/STAR Operating System, Revision 2.48. This change notice also corrects miscellaneous errors and omissions in the original manual.

To update your manual, find the page number in your manual that matches each page supplied. Then remove the original page and replace it with the new page. In some cases, it was necessary to add additional pages between existing pages. These are assigned a letter following the applicable page number. For example, page 7-7A supplied with this change notice should be inserted after page 7-7. Pages 7-7B, C, D, E, F, G, and H follow. Page 7-8 follows page 7-7H.

Insert the Manual Update Subscription Form inside the back cover of the manual.

Note that each new page has a date code to indicate that it is different from the original page.

After you have updated your manual, place this page and pages 2.48-2 through 2.48- inside the front cover of the manual to serve as a history of changes to the manual.

As always, we welcome your comments and constructive criticisms of the manual and its updates. Use the Reader Response Card in the back of the manual for this purpose, or contact:

Molecular Computer
Technical Publications Department
251 River Oaks Parkway
San Jose, California 95134

n/STAR Revision 2.48 Features and Enhancements

Revision 2.48 of the n/STAR Operating System added several new features and enhanced several existing features. Those features affecting users of the system are described in detail in the replacement pages supplied with this change notice. For quick reference, here is a list of the features and enhancements:

- Software is now supplied on three Distribution Diskettes: n/STAR, Diagnostic, and CP/M.
- The following errors in the operating system were corrected:

SYSINT now accepts upper and lower case input.

The SELECT PHYSICAL ERROR MODE REQUEST has been disabled. This M/PM request is not compatible with n/STAR.

Locking a locked record now causes a NOP.

DESPool is now supported on 8003 application processors.

LOCAL printer is now supported on 8003 application processors.

n/STAR Distribution and Update files have now been merged onto one diskette; therefore, to reinstall software in the field, SUBMIT ONE and SUBMIT TWO are now supported.

- NEW DISK CONFIGURATIONS are supported, including 7 and 12 partitions on Supermicro 64 systems with 60MB hard disk drives.
- HASHED DIRECTORY SEARCH speeds system response when searching for a file, especially when the file is not found.
- REMOTE TERMINAL SUPPORT is now provided allowing handshaking between remote terminal and computer and providing automatic coldstart and logoff when RTS goes low.
- ACQUIRE AND RELEASE DEVICE REQUESTS have been added to allow applications to control both devices and "system resource" applications processors (16-bit AP/86 and "extra" Z80 APs)

- AUTOMATIC QUEUING OF SPOOL FILES is now possible via processor coldstart.
- BANNERS can now be specified to print during despooling, to help identify a printing job and its owner.
- VERSION NUMBER of n/STAR can now be requested and compared by an application.
- COLDSTART AND WARMSTART requests have been added to inform the application of processor status.
- TLINK terminal communication program will allow users to acquire and link to "system resource" type applications processors including AP/86s and "extra" Z80 APs. Up to five separate processors may be aquired by a user at one time. This feature also facilitates system-to-system communications via application processors.
- NEWCON is a new n/STAR command which allows the system manager to allocate "extra" application processors as system resources which may then be "TLINKed."
- DEVICES command lists the currently created devices and their attributes.
- WHO is a new command that lists the processors and users on the system.

SUPERMICRO INSTALLATION AND USER REFERENCE MANUAL

CHANGE NOTICE #2

This change notice updates your Supermicro Installation and User Reference Manual to correct errors found since the last printing. Before updating your manual with this change notice, be sure you have first updated it with "Change Notice #1."

To update your manual:

Remove page 2-12 dated 010383; replace with page 2-12 dated 021083

Add page 3-7A dated 021083 after page 3-7.

Remove page 7-10 dated 121582; replace with page 7-10 dated 021083

After you have updated your manual, place this page near the front cover of the manual, behind page 2.48-3 to serve as a history of changes to the manual.

As always, we welcome your comments and constructive criticisms of the manual and its updates. Use the Reader Response Card in the back of the manual for this purpose, or contact:

Molecular Computer
Technical Publications Department
251 River Oaks Parkway
San Jose, California 95134

CHANGE NOTICE PART NUMBER: 87100190

SUPERMICRO INSTALLATION AND USER REFERENCE MANUAL

CHANGE NOTICE #3

This change notice updates your **Supermicro Installation and User Reference Manual** to describe the current revision of the n/STAR Operating System, Revision 2.49. This change notice also corrects miscellaneous errors and omissions in the original manual.

To update your manual, find the page number in your manual that matches each page supplied. Then remove the original page and replace it with the new page. Remove page 3-7A added in Change Notice #2.

Note that each new page has a date code to indicate that it is different from the original page. Note also that a black stripe in the outside margin indicates the information which has been changed.

After you have updated your manual, place this page and pages 2.49-2 through 2.48-2 inside the front cover of the manual to serve as a history of changes to the manual.

As always, we welcome your comments and constructive criticisms of the manual and its updates. Use the Reader Response Card in the back of the manual for this purpose, or contact:

Molecular Computer
Technical Publications Department
251 River Oaks Parkway
San Jose, California 95134

CHANGE NOTICE PART NUMBER 87100220

n/STAR Revision 2.49 Features and Enhancements

Revision 2.49 of the n/STAR Operating System added several new features and enhanced several existing features. Those features affecting users of the system are described in detail in the replacement pages supplied with this change notice. For quick reference, here is a list of the features and enhancements:

- The following errors in the operating system were corrected:

RESET now resets any Application Processor.

The banner for despooling printers no longer duplicates the first banner character.

DESPOOL no longer requires CTS on the B port to print; it now only requires DTR.

BDOS error/BIOS list conflict is corrected.

SET.COM is now being distributed on the n/STAR Distribution Diskette.

TLINK is corrected to reset Z80 Application Processors when invoked, and to report an error when a device is removed from the system when the DEVICES entry still exists (this formerly caused TLINK to hang).

SETBAUD now correctly sets 19.2K baud on AP8020s.

WHO now correctly identifies X series processors.

- NEW DISK CONFIGURATIONS are supported for several new system configurations.
- AUTOMATIC QUEUING OF SPOOLED FILES now occurs on a warmstart as well as a coldstart.
- IMAGE is a new utility to allow a "mirror-image" copy of all programs, data, and boot tracks on a diskette.
- SELDRIVE is a new program that lets you select one of four hard disk drives while in Diagnostic Mode. This lets you backup and restore the hard disks when your system has more than 16 partitions (a current CP/M limitation).



READER COMMENTS

Please use this mailer to send your comments on the Supermicro and the Supermicro manuals. If you require more space for your comments, please attach a separate sheet. Indicate at the bottom of this form if you would like a reply to your comments.

NAME OF MANUAL _____

N/STAR VERSION NO. _____ MANUAL EDITION NO. _____

What features of the Supermicro do you like?

What features of the Supermicro don't you like or you feel are missing?

Are there specific points in the manual that need clarification or correction? Give details with page and paragraph references.

Did you find the manual easy to use and understand? Do you think certain aspects should be organized differently? Was any necessary material omitted or was any material unnecessary?

Did you find sufficient information provided in the manual for proper system set up and installation?

Additional comments: _____

NAME _____ DATE _____

COMPANY OR ORGANIZATION _____

TYPE OF BUSINESS _____

STREET _____

CITY, STATE, ZIP _____

Tear along perforation

Fold

Fold



NO POSTAGE
NECESSARY
IF MAILED
IN THE
UNITED STATES

Business Reply Mail
First Class Permit No. 101 San Jose, CA

Postage will be paid by addressee



molecular computer

Molecular Computer
251 River Oaks Parkway
San Jose, CA 95134 USA

**Attention:
Marketing Department**

