

**KAYPRO TECHNICAL MANUAL**

**AUGUST 1984**

**Part Number 1484-C**

## CONTENTS

SECTION		PAGE
1.0	Introduction	
1.1	Purpose of Technical Manual	1--1
1.2	Scope of Technical Manual	1--2
2.0	FCC Information	2--1
3.0	Model Specifications	
3.1	KAYPRO 2	3--1
3.2	KAYPRO 2/84 and 2X	3--2
3.3	KAYPRO 4	3--3
3.4	KAYPRO 4/84	3--4
3.5	KAYPRO 4X	3--5
3.6	KAYPRO 10	3--6
3.7	KAYPRO ROBIE	3--7
4.0	ROM Revisions — CP/M Compatibility	4--1
5.0	Chassis	
5.1	Removal/Replacement of Hood (Exc. ROBIE)	5--1
5.2	Touch-up Information	5--2
6.0	Mainboards—Troubleshooting Tips	6--1
6.1	KAYPRO 2 (81-110-n)	6--2
6.2	KAYPRO 2/4 (81-240-n)	6--8
6.3	KAYPRO 10 (81-180-n)	6--16
6.4	KAYPRO 2/84 and 2X (81-294-n)	6--26
6.5	KAYPRO 4/84 (81-184)	6--35
6.6	KAYPRO ROBIE (81-296-n)	6--44
6.7	Removal/Installation Instructions	6--53
7.0	CRT Assemblies	
7.1	Descriptions and Adjustments	7--1
7.2	Video Alignment	7--3
7.3	Video Signals on KAYPRO Mainboard	7--4
7.4	ALIGN.MAC Diagnostic Listing	7--5
7.5	Removal/Installation Instructions	7--8

## CONTENTS (Continued)

SECTION		PAGE
8.0	Power Supplies	
8.1	Introduction	8--1
8.2	Description and 220V Configuration	8--2
8.3	Removal/Installation Instructions	8--5
9.0	Diskette Drives	
9.1	Introduction/Disk Drive Cleaning	9--1
9.2	Which Brand of Drive Is It?	9--2
9.3	Jumpering Diagrams	9--5
9.4	High-Density (Drivetec) Drives	9--9
9.5	Removal/Installation Instructions	9--10
10.0	Hard Disk Drives (KAYPRO 10)	
10.1	Introduction	10--1
10.2	Description	10--2
10.3	Hard Drive Configuration	10--3
10.4	Hard Drive or Floppy Drive Removal/ Installation Instructions (KAYPRO 10)	10--4
11.0	Hard Drive Controller Board (KAYPRO 10)	
11.1	Description	11--1
11.2	Removal/Installation Instructions	11--2
12.0	Interface Board (KAYPRO 10)	
12.1	Description	12--1
12.2	Removal/Installation Instructions	12--2
13.0	Keyboards	13--1
14.0	ROBIE Removal/Installation Instructions	
14.1	Chassis Covers	14--1
14.2	Diskette Drives	14--2

## CONTENTS (Continued)

SECTION		PAGE
15.0	Troubleshooting	
15.1	Introduction	15--1
15.2	KAYPRO 2 and 4 Symptom--Fix Guides	15--2
15.3	KAYPRO 10 Symptom--Fix Guide	15--8
15.4	ROBIE Symptom--Fix Guide	15--15
15.5	KAYPRO 2/84 and 2X Symptom--Fix Guide	15--21
15.6	KAYPRO 4/84 and 4X Symptom--Fix Guide	15--22
16.0	System I/O	
16.1	Video Command Protocol	16--1
16.2	Keyboard Codes and Functions	16--2
16.3	Connector Pin-Outs	16--3
16.4	Port Addresses	16--10
17.0	Reference Section	
17.1	ASCII Chart	17--1
17.2	Memory Maps	17--2
17.3	Vendor Addresses	17--6
18.0	Suggested References	18--1

INDEX

## 1.0 INTRODUCTION

### 1.1 PURPOSE OF TECHNICAL MANUAL

This publication is intended to be a technical reference guide to be used by trained repair technicians. It will attempt to cover all dealer-serviceable sections of Kaypro computers. This manual replaces previous manuals on the subject.

The procedures and information contained in this manual assume technical expertise on the part of the reader. To avoid personal injury, do not perform any servicing unless you are a qualified service technician.

It is our desire to provide dealers with the information and support needed to expedite repairs and provide the users with the service they deserve. We encourage your comments and suggestions regarding this manual.

## 1.2 SCOPE OF TECHNICAL MANUAL

The information and procedures covered by this manual assume some technical knowledge on the part of the reader.

The policy of Kaypro Corporation is to repair computers to the modular level only. Even Kaypro's repair technicians do not repair switching power supplies, CRT assemblies, or disk drives. Repairs to modular components not manufactured by Kaypro Corporation (power supplies, CRT assemblies, disk drives) are NOT covered by this manual.

However, we do not discourage dealers and technicians who have the knowledge and the tools to repair to the component level from doing so, on out-of-warranty Kaypro computers.

The adjustment and removal/replacement information in this manual is organized by module type, with the exception of removal/replacement information for the KAYPRO ROBIE, which is placed in a separate section due to the differences in chassis design and hardware module placement in that machine.

## **2.0 FCC INFORMATION**

As Kaypro keeps in step with computer technology, the models have changes which affect FCC ratings. The proper rating is affixed to the back of each computer. Contact the Kaypro Engineering Department if you need further information.

### 3.0 MODEL SPECIFICATIONS

#### 3.1 KAYPRO 2 SPECIFICATIONS

CPU	Z-80 2.5 MHz
RAM	64K bytes
MAINBOARD	81-110-n or 81-240-n series.
DISK STORAGE	Two 5-1/4 inch, double-density, single-sided, floppy disk drives, providing 191K bytes of storage per diskette.
KEYBOARD	Detachable, 72 key typewriter style keyboard with 18 programmable keys.
VIDEO SCREEN	Non-glare, 9-inch, green phosphor screen with a 25 row x 80 column display.
I/O CONNECTIONS	One "Centronics"-type parallel port, one RS-232C serial port.



### 3.2 KAYPRO 2/84 and 2X SPECIFICATIONS

CPU	Z80-A 4.0 MHz
RAM	64K bytes
MAINBOARD	81-294-n series.
DISK STORAGE (Kaypro 2/84)	Two 5-1/4 inch double-density, single-sided, floppy disk drives, providing 191K bytes of storage per diskette.
DISK STORAGE (Kaypro 2X)	Two 5-1/4 inch double-density, double-sided, floppy disk drives, providing 390K bytes of storage per diskette.
KEYBOARD	Detachable, 72 key typewriter style keyboard with 18 programmable keys.
VIDEO SCREEN	Non-glare, 9-inch, green phosphor screen with a 25 row x 80 column display.
I/O CONNECTIONS	One "Centronics"-type parallel port, two RS-232C serial ports.

### 3.3 KAYPRO 4 SPECIFICATIONS

CPU	Z-80 2.5 MHz
RAM	64K bytes
MAINBOARD	81-240-n series.
DISK STORAGE	Two 5-1/4 inch double-density, double-sided, floppy disk drives, providing 390K bytes of storage per diskette.
KEYBOARD	Detachable, 72 key typewriter style keyboard with 18 programmable keys.
VIDEO SCREEN	Non-glare, 9-inch, green phosphor screen with a 25 row x 80 column display.
I/O CONNECTIONS	One "Centronics"-type parallel port, one RS-232C serial port.

### 3.4 KAYPRO 4/84 SPECIFICATIONS

CPU	Z-80A 4.0 MHz
RAM	64K bytes
MAINBOARD	81-184-n series.
DISK STORAGE	Two double-density, double-sided, floppy disk drives, providing 390K bytes of storage per diskette.
KEYBOARD	Detachable, 72 key typewriter style keyboard with 18 programmable keys.
VIDEO SCREEN	Non-glare, 9-inch green phosphor screen with a 25 row x 80 column display.
I/O CONNECTIONS	One "Centronics"-type parallel port, two RS-232C serial ports, one RJ11C modular telephone jack.
MODEM	Built-in, 300-baud modem, with Bell System 103 compatibility. Uses Texas Instruments TMS99531/TMS99532.
REAL-TIME CLOCK	Built-in real-time clock. Uses National MM58167.

### 3.5 KAYPRO 4X SPECIFICATIONS

CPU	Z-80A 4.0 MHz
RAM	64K bytes
MAINBOARD	81-296-n series.
DISK STORAGE	Two 5-1/4 inch, high-density, double-sided, floppy disk drives providing 2.6M bytes of storage per diskette.
KEYBOARD	Detachable, 72 key typewriter style keyboard with 18 programmable keys.
VIDEO SCREEN	Non-glare, 9-inch, green phosphor screen with a 25 row x 80 column display.
I/O CONNECTIONS	One "Centronics"-type parallel port, two RS-232C serial ports, one RJ11C modular telephone jack.
MODEM	Built-in, 300-baud modem, with Bell System 103 compatibility. Uses Texas Instruments TMS99531/TMS99532.
REAL-TIME CLOCK	Built-in real-time clock. Uses National MM58167.

### 3.6 KAYPRO 10 SPECIFICATIONS

CPU	Z80A, 4.0 MHz
RAM	64K bytes
MAINBOARD	81-180-n series.
DISK STORAGE	One 5-1/4 inch double-density, double-sided, floppy disk drive providing 390K bytes of storage per diskette. One hard disk drive providing 10M bytes of storage.
KEYBOARD	Detachable, 72 key typewriter style keyboard with 18 programmable keys.
VIDEO SCREEN	Non-glare, 9-inch, green phosphor screen with a 25 row x 80 column display.
I/O CONNECTIONS	One "Centronics"-type parallel port, two RS-232C serial ports.

### 3.7 KAYPRO ROBE SPECIFICATIONS

CPU	Z80A, 4.0 MHz
RAM	64K bytes
MAINBOARD	81-296-n series.
DISK STORAGE	Two 5-1/4 inch, high-density, double-sided, floppy disk drives providing 2.6M bytes of storage per diskette.
KEYBOARD	Detachable, 72 key typewriter style keyboard with 18 programmable keys.
VIDEO SCREEN	Non-glare, 9-inch, green phosphor screen with a 25 row x 80 column display.
I/O CONNECTIONS	One "Centronics" type parallel port, two RS232C serial ports, one RJ11C modular telephone jack.
MODEM	Built-in, 300-baud modem, with Bell System 103 compatibility. Uses Texas Instruments TMS99531/TMS99532.
REAL-TIME CLOCK	Built-in real-time clock. Uses National MM58167.

#### 4.0 KAYPRO ROM REVISION—CP/M VERSION COMPATIBILITY

MODEL NAME	CP/M VERSION	KAYPRO PART # (for CP/M disk)	ROM VERSION
2/83	2.2F	0777	81-149-C or 81-232-A
4/83	2.2F	1475	81-232-A
4/83 + 88	2.2F	1475	81-232-A
2/84	2.2G	2619	81-292-A
4/84	2.2G	2622	81-292-A
4/84 + 88	2.2G	2622	81-292-A
2 X	2.2G	2470	81-292-A
4 X	2.2G	2340	81-326-E
ROBIE	2.2G	2340	81-326-E

## **5.0 CHASSIS**

### **5.1 CHASSIS HOOD REMOVAL (EXCEPT KAYPRO ROBIE)**

1. Turn off the machine.
2. Disconnect AC power by unplugging the power cord from wall outlet.
3. Remove the ten screws from the chassis hood; there are two on top and four on each side.
4. Remove the hood from the chassis.

### **CHASSIS HOOD REPLACEMENT**

1. Lower the hood onto the unit.
2. Align the two holes on top of the hood with those on top of the chassis.
3. Insert the two flat-head screws into the holes on the top of the chassis and start them, but do not tighten them yet.
4. Insert the eight round-head screws, four on each side, and start them.
5. Tighten each screw securely.



## 5.2 TOUCH-UP INFORMATION

Kaypro Corporation has small amounts of touch-up paint for Kaypro hoods and chassis available to the dealers. Contact the Hardware Technical Support personnel to obtain this paint.

Occasionally a customer's computer will have scratches on the hood or chassis. A small amount of rubbing compound, when carefully applied, will often smooth out very small scratches on a hood or chassis. Should painting be necessary, there are two sizes of sable paintbrushes to have on hand: size 00 and size 000. These brushes are available at any art supply store.

## 6.0 MAINBOARDS

The following sections contain schematics, chip layout diagrams, and IC lists (by U-number) for Kaypro mainboards. This is not intended to be a theory of operation, but rather an aid to locating possible problems on a mainboard.

Consult an appropriate databook (TTL, Zilog, etc.) if you need to find out the internal workings of a particular IC.

### MAINBOARD TROUBLESHOOTING TIPS:

A blank EPROM can be used to help troubleshoot Kaypro mainboards of series 81-110, 81-240, and 81-180. The appropriate model of EPROM (2732, 2716, etc) allows a quick check of the board. It will usually force the data and address lines to toggle at approximately the same amplitude, allowing the technician to use a scope to spot affected lines.

If the video display does not show a screen filled with alternating "9"s and apostrophes, you have a problem in the video RAM or associated circuitry.

You can check the main RAM and associated circuitry quickly with a scope by looking at pin 14 on each of the RAM chips. There should be a pattern of signals like this:

For the 81-240 board:

U20 (D7)	low
U21 (D6)	low
U22 (D5)	toggle
U23 (D4)	toggle
U24 (D3)	toggle
U25 (D2)	low
U26 (D1)	low
U27 (D0)	toggle

The U-numbers of the main RAM chips will vary depending on which mainboard you have, but the pattern will be the same.

6.1 KAYPRO 2 (81-110-n)

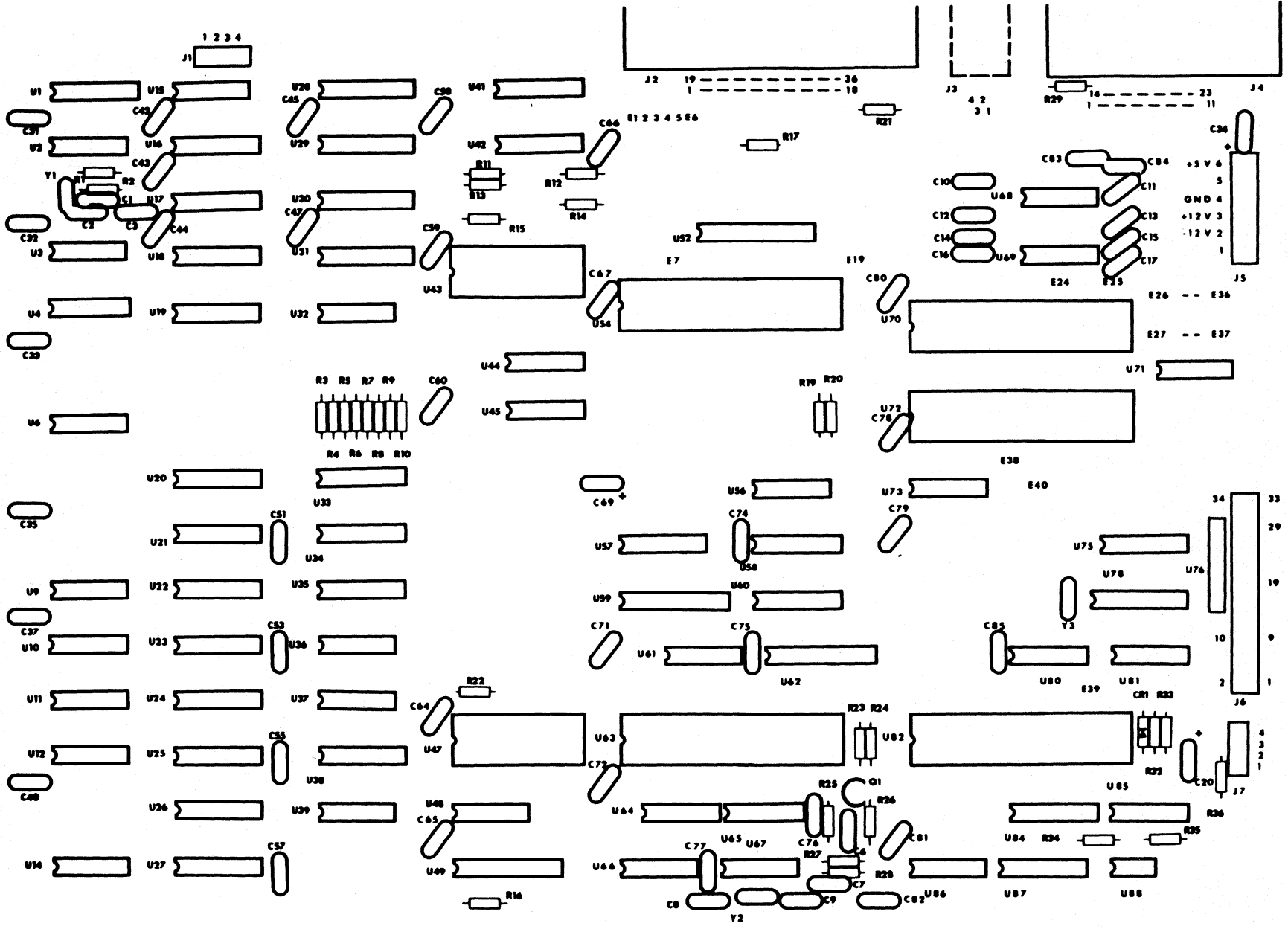

## IC LIST, KAYPRO 2 (81-110-n)

Reference Designation		Description
U1	74LS161	4-bit counter
U2, U67*	74HCU04	Hex inverter, CMOS
U3	74LS290	decade counter
U4	74LS10	Tri NAND gates
U6, U11	74LS393	Dual binary counter
U9, U80	74LS08	Quad AND gates
U10, U61	73LS32	Quad OR Gates
U12, U14, U32	74LS74	Dual "D" flip-flop
U15, U39	74LS00	Quad NAND Gates
U16 through U19	74LS157	Quad 2/1 MUX
U20 through U27	MCM6665	(or equivalent) 64K x 1 RAM
U28 through U31	2114	1K x 4 RAM
U33, U34	74157	Quad 2/1 MUX
U35, U38	8216	Quad Bi-directional MUX
U36	74LS20	Dual NAND gates
U37, U56, U85	74LS02	Quad NOR gates
U41	74S151	8/1 MUX
U42	74LS174	Hex "D" flip-flop
U43	81-146	Character generator EPROM
U44, U45, U64, U65	74LS243	Quad bus trans
U47	81-149	Boot EPROM
U48, U73	74LS04	Hex inverter
U49, U52, U62	74LS241	Octal buffer
U54, U72	Z80 PIO	
U57, U58, U60	74LS138	3/8 MUX
U59	74LS373	Octal "D" latch
U63	Z80 CPU	
U66	74164	8-bit shift register
U68	1488	Quad line driver (OUT)
U69	1489	Quad SCHMITT line receiver (IN)
U70	Z80 SIO	
U71	74S04	Hex inverter
U78	8116	Dual programmable baud rate generator
U81	7406	Hex inverter, open collector
U82	FD1793	Floppy disk controller
U84	74LS195	4-bit shift register
U86	74LS293	4-bit binary counter
U87	74LS390	Dual decade counter
U88	FDC9216	Data separator

\*NOTE: THERE ARE SOME VERSIONS OF THE 81-110 BOARD ON WHICH U2 AND U67 ARE NOT CMOS IC.S BUT ARE NORMAL TTL IC.S. READ THE NUMBER ON THE IC TO BE SURE.

## SCOPE SIGNALS TO AID IN TROUBLESHOOTING (81-110-n)

The examples of correct signals shown below do not represent all of the signals on a Kaypro mainboard, since most signals will be simple high-low toggles. A group of video signals (CC0 through CC3) are included as illustrations of the timing relationships between the various video signals. Note that only one of the I/O signals on U57 will be low at any given time.

State of the machine: The door of drive A is open; the machine is waiting to boot.

The signal measurements were made using a Tektronix oscilloscope, model 2213. It has a bandwidth of DC-60 MHz, sensitivity of 2mV/cm, a sweep delay of 0.1 microseconds to 1 second, and a graticule display measuring 8 x 10 cm.

Signal M1 from pin 27 of the CPU (U63) was triggered on. This signal is shown in the top half of each display and was channel 1. Ground for the signals shown on channel 2 was established at first graticule line above the bottom of the display.

Each square of the representation is the equivalent of one square cm on the graticule. The scope was set for 2V/div. for all figures, and was set for .5 micro-secs/div. for all figures EXCEPT figure 6, which was taken using 1 micro-secs/div.

Figure 1: Pin 6 of U63, 2.5MHz clock signal.

Figure 2: Pin 24 of U82, 1MHz clock signal.

Figure 3: Pin 3 of U6, CC0.

Figure 4: Pin 4 of U6, CC1.

Figure 5: Pin 5 of U6, CC2.

Figure 6: Pin 6 of U6, CC3.

FIGURE 1

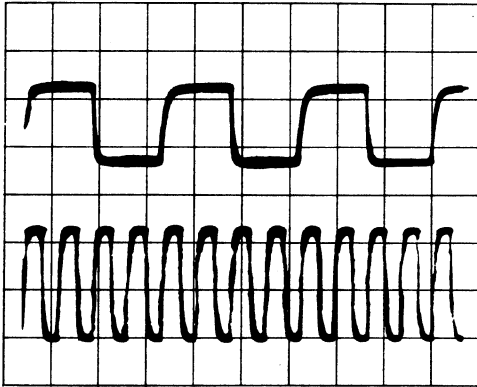

FIGURE 2

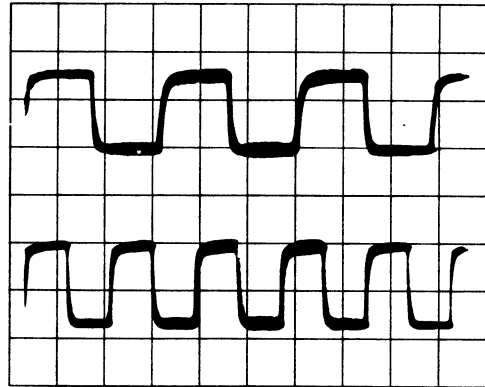

FIGURE 3

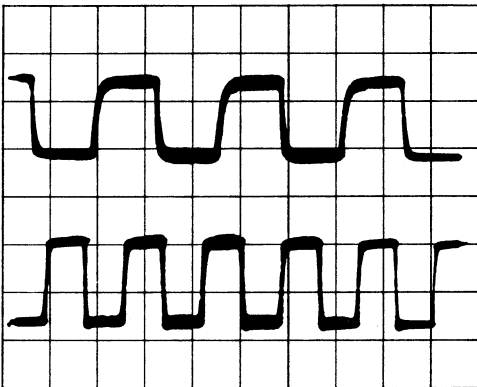

FIGURE 4

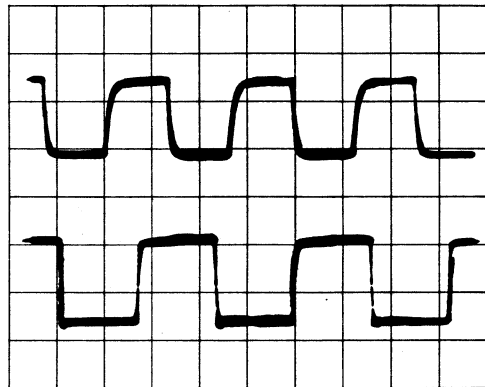

FIGURE 5

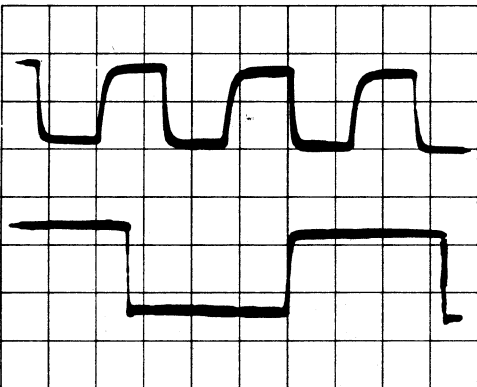
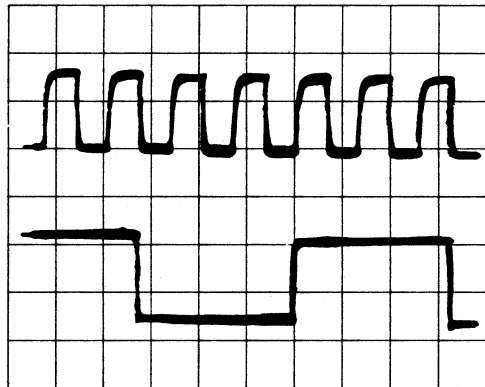

FIGURE 6



**SIGNAL LOCATIONS ON MAINBOARD 81-110-n**

<u>SIGNAL</u>	<u>IC LOCATION</u>	<u>PIN NO.</u>
<b>CPU SIGNALS</b>		
2.5 MHz	U 63	6
MREQB	U 62	16
RDB	U 62	5
WRB	U 62	14
<b>MEMORY SIGNALS</b>		
RAS	U 39	11
CAS	U 66	5
MUXC	U 66	4
<b>VIDEO CLOCK SIGNALS</b>		
CLOCK, Y1	U 2	8
CC0	U 6	3
CC1	U 6	4
CC2	U 6	5
CC3	U 6	6

6-6.1

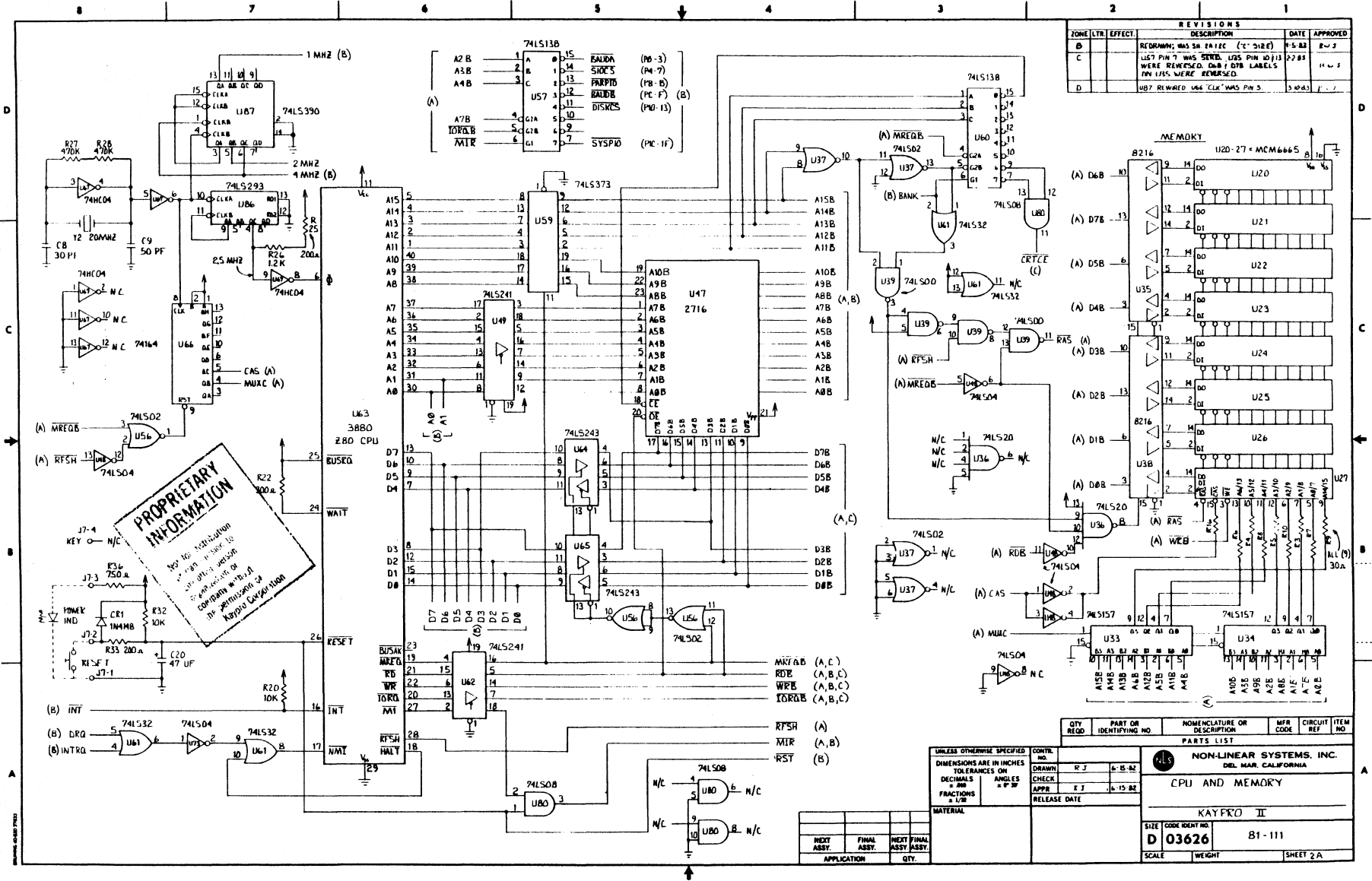



6-6.2

REVISIONS				
ZONE (LTR)	EFFECT	DESCRIPTION	DATE	APPROVED
B		RECORDING HAS 54 281 RE (T. SHER)	5-5-83	R. W. F.
C		US5, PM 4 HAD NO BUBBLE. U70 PM 35 HAS SERIAL, ADDED GND INFO ON J2, J4	7-2-83	R. W. F.
D		U70, PM 3 WAS LABELED F1; PM 17, F2	7-29-84	R. W. F.

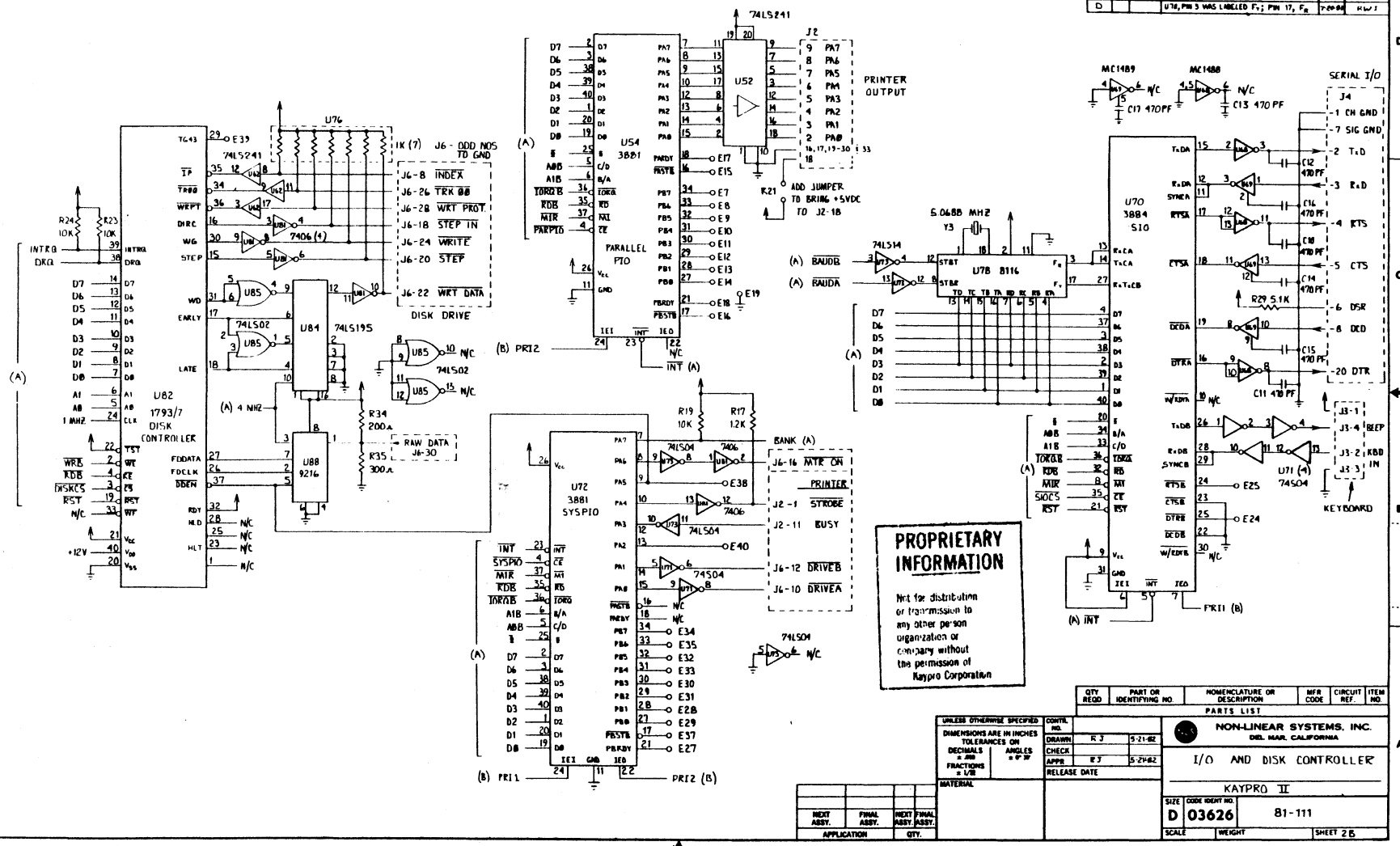

**PROPRIETARY INFORMATION**  
 Not for distribution or transmission to any other person, organization or company without the permission of Kaypro Corporation.

QTY REQD	PART OR IDENTIFYING NO	NOMENCLATURE OR DESCRIPTION	MFR CODE	CIRCUIT REF.	ITEM NO.
PARTS LIST					
UNLESS OTHERWISE SPECIFIED					
DIMENSIONS ARE IN INCHES					
TOLERANCES ON DECIMALS = .010 ANGLES = 9° ± .1°					
FRACTIONS = 1/32					
MATERIAL					
CONTROL NO. R 3 5-21-82					
DRAWN CHECK APPR. R 3 5-24-82					
RELEASE DATE					
NON-LINEAR SYSTEMS, INC. DEL. MAR. CALIFORNIA					
I/O AND DISK CONTROLLER					
KAYPRO II					
SIZE (DRAWING NO.) D 03626 81-111					
SCALE WEIGHT SHEET 2 B					

APPLICATION	QTY.
NEXT ASSY.	
FINAL ASSY.	
NEXT FINAL ASSY.	
FINAL ASSY.	

6-6.3

REVISIONS					
ZONE	LTR	EFFECT	DESCRIPTION	DATE	APPROVED
B			REDRAWN; WAS SH 28 (R' SHEET)	1-5-83	R-3
C			U3 PIN 15 WAS N/C	5-2-83	P-7

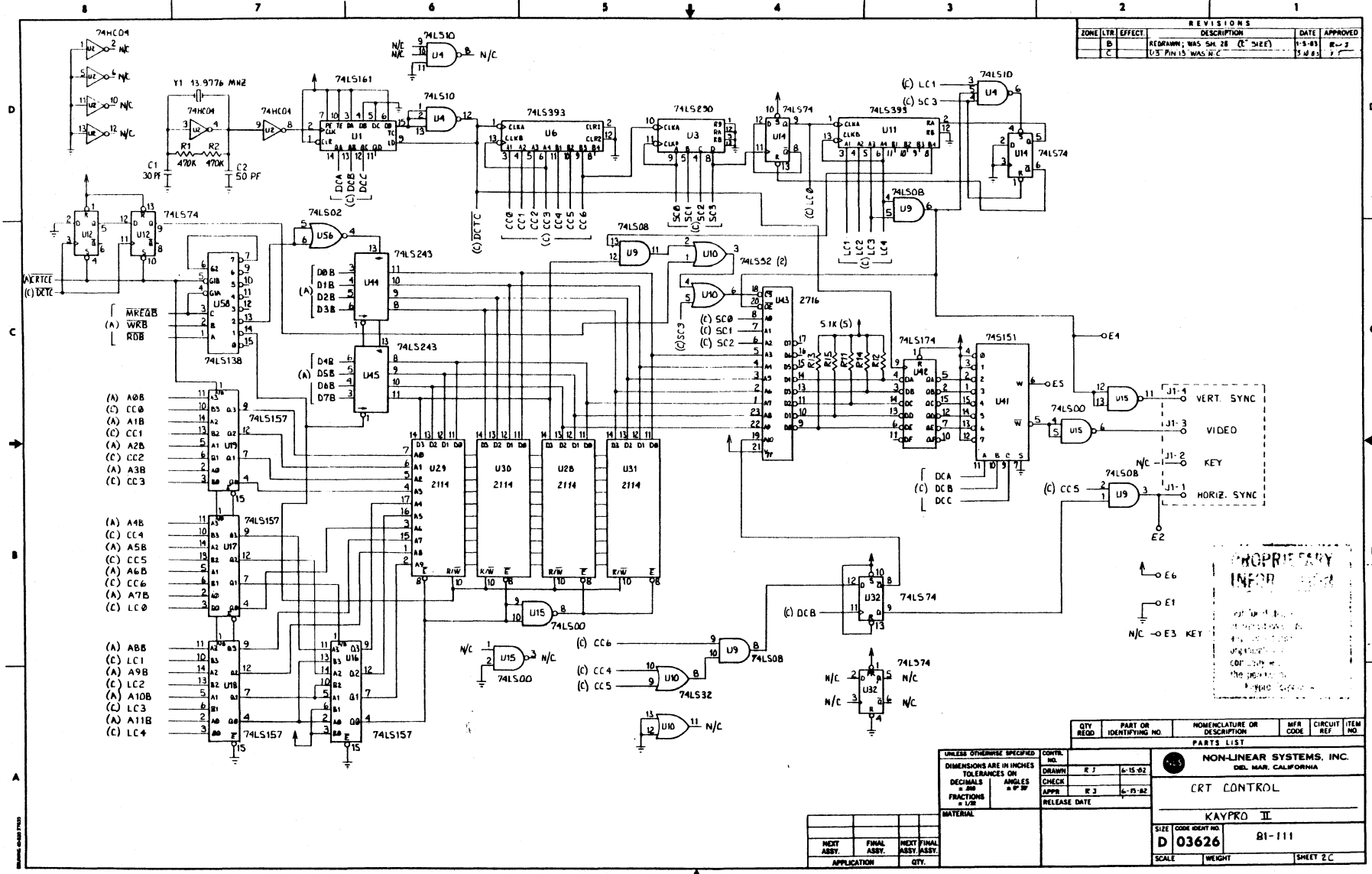

- (A) A0B
- (C) CC0
- (A) A1B
- (C) CC1
- (A) A2B
- (C) CC2
- (A) A3B
- (C) CC3
  
- (A) A4B
- (C) CC4
- (A) A5B
- (C) CC5
- (A) A6B
- (C) CC6
- (A) A7B
- (C) LC0
  
- (A) A8B
- (C) LC1
- (A) A9B
- (C) LC2
- (A) A10B
- (C) LC3
- (A) A11B
- (C) LC4

**PROPRIETARY**  
**INFORMATION**  
 ALL INFORMATION CONTAINED HEREIN IS UNCLASSIFIED  
 DATE 10-10-2010 BY 60322 UCBAW/SJS

QTY	PART OR IDENTIFYING NO.	NOMENCLATURE OR DESCRIPTION	MFR CODE	CIRCUIT REF	ITEM NO.
PARTS LIST					
NON-LINEAR SYSTEMS, INC. DEL MAR, CALIFORNIA					
CRT CONTROL					
KAYPRO II					
SIZE	CODE IDENT NO.			81-111	
D	03626				
SCALE	WEIGHT			SHEET 2 C	

UNLESS OTHERWISE SPECIFIED	CONTR. NO.
DIMENSIONS ARE IN INCHES	R 3
TOLERANCES ON DECIMALS	6-15-82
ANGLES ± 30'	
FRACTIONS ± 1/32"	
RELEASE DATE	

MATERIAL	RELEASE DATE

NEXT ASSY.	FINAL ASSY.	NEXT FINAL ASSY.	FINAL ASSY.

APPLICATION	CITY

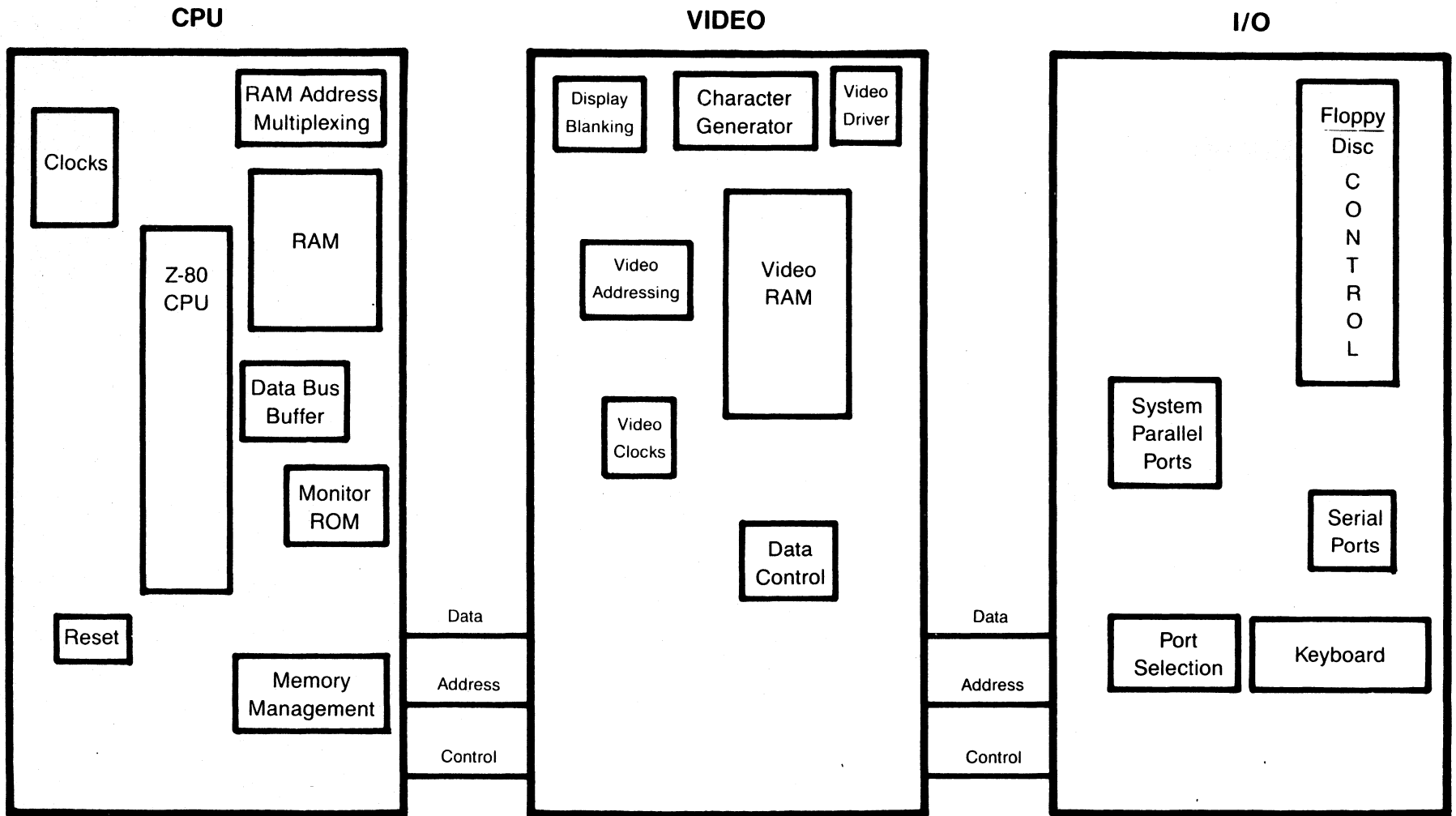

KAYPRO 2 and 4 BLOCK DIAGRAM

6.2 KAYPRO 2/4 (81-240-n)

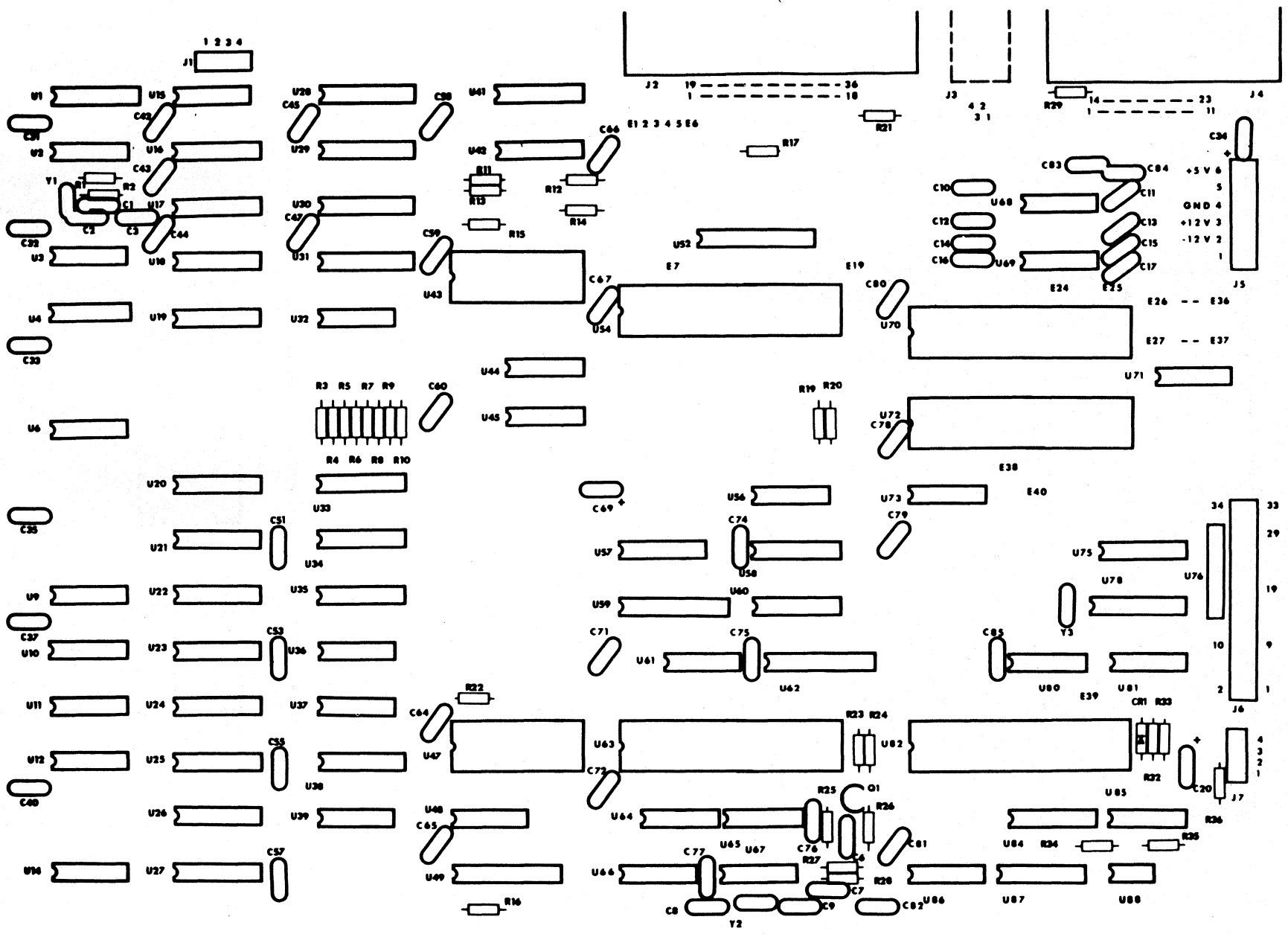

6-8

IC LIST, KAYPRO 2/4 (81-240-n)

Reference Designation		Description
U1	74LS161	4-bit counter
U2, U67	74HCU04	Hex inverter, CMOS
U3	74LS290	Decade counter
U4	74LS10	Tri NAND gates
U6, U11	74LS393	Dual binary counter
U9, U80	74LS08	Quad AND gates
U10, U61	73LS32	Quad OR Gates
U12, U14, U32	74LS74	Dual "D" flip-flop
U15, U39	74LS00	Quad NAND Gates
U16 through U19	74LS157	Quad 2/1 MUX
U20 through U27	MCM6665	(or equivalent) 64K x 1 RAM
U28 through U31	2114	1K x 4 RAM
U33, U34	74157	Quad 2/1 MUX
U35, U38	8216	Quad Bi-directional MUX
U36	74LS00	Dual NAND gates
U37, U56, U85	74LS02	Quad NOR gates
U41	74S151	8/1 MUX
U42	74LS174	Hex "D" flip-flop
U43	81-146-n	Character generator EPROM
U44, U45, U64, U65	74LS243	Quad bus trans
U47	81-232-n	Boot EPROM
U48, U73	74LS04	Hex inverter
U49, U52, U62	74LS241	Octal buffer
U54, U72	Z80 PIO	
U57, U58, U60	74LS138	3/8 MUX
U59	74LS373	Octal "D" latch
U63	Z80 CPU	
U66	74164	8-bit shift register
U68	MCL488	Quad line driver (OUT)
U69	MCL489	Quad SCHMITT line receiver (IN)
U70	Z80 SIO	
U71	74S04	Hex inverter
U78	8116	Dual programmable baud rate generator
U81	7406	Hex inverter, open collector
U82	1793	Floppy disk controller
U84	74LS195	4-bit shift register
U86	74LS293	4-bit binary counter
U87	74LS390	Dual decade counter
U88	FDC9216	Data separator

## SCOPE SIGNALS FOR TROUBLESHOOTING 81-240-n

The examples of correct signals shown below do not represent all of the signals on a Kaypro mainboard, since most signals will be simple high-low toggles. A group of video signals (CC0 through CC3) are included as illustrations of the timing relationships between the various video signals. Note that only one of the I/O signals on U57 will be low at any given time.

State of the machine: with a blank, 2732, EPROM inserted in place of normal EPROM at location U 47. The door of drive A is open; the machine is waiting to boot.

The signal measurements were made using a Tektronix oscilloscope, model 2213. It has a bandwidth of DC-60 MHz, sensitivity of 2mV/cm, a sweep delay of 0.1 microseconds to 1 second, and a graticule display measuring 8 x 10 cm.

Signal M1 from pin 27 of the CPU (U63) was triggered on. This signal is shown in the top half of each display and was channel 1. Ground for the signals shown on channel 2 was established at first graticule line above the bottom of the display.

Each square of the representation is the equivalent of one square cm on the graticule. The scope was set for 2V/div. for all figures, and was set for .5 micro-secs/div. for all figures EXCEPT figure 6, which was taken using 1 micro-secs/div.

Figure 1: Pin 6 of U63, 2.5MHz clock signal.

Figure 2: Pin 24 of U82, 1MHz clock signal.

Figure 3: Pin 3 of U6, CC0.

Figure 4: Pin 4 of U6, CC1.

Figure 5: Pin 5 of U6, CC2.

Figure 6: Pin 6 of U6, CC3.

FIGURE 1

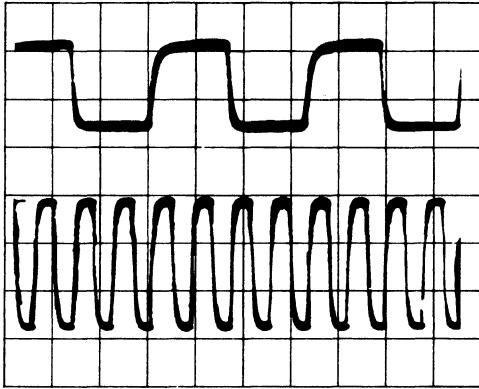

FIGURE 2

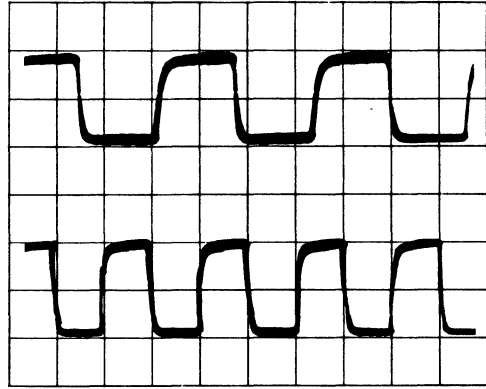

FIGURE 3

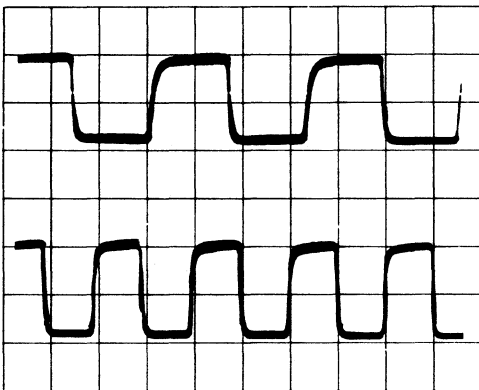

FIGURE 4

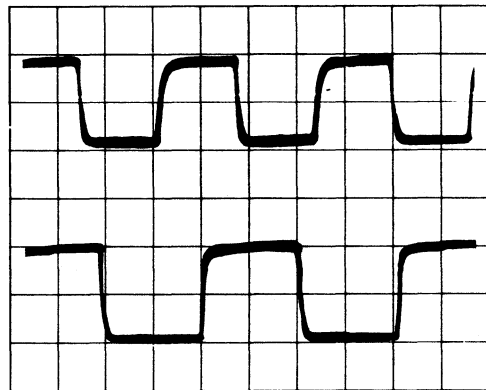

FIGURE 5

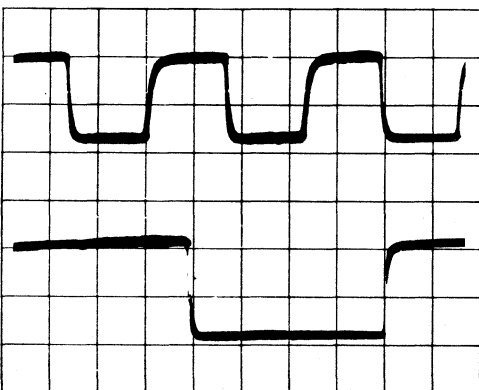
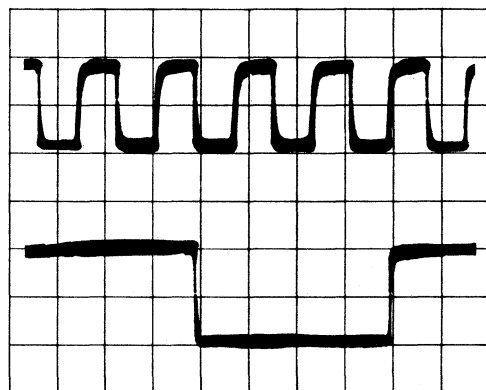

FIGURE 6



**SIGNAL LOCATIONS, 81-240-n**

<u>SIGNAL</u>	<u>IC</u> <u>LOCATION</u>	<u>PIN NO.</u>
<b>CPU SIGNALS</b>		
CPU clock	U 67	6
1 MHz	U 87	13
2 MHz	U 87	3
MREQB	U 62	16
RDB	U 62	5
MLR (reference)		
<b>MEMORY SIGNALS</b>		
RAS	U 39	11
CAS	U 66	5
MUXC	U 66	4
<b>VIDEO CLOCK SIGNALS</b>		
CLOCK, Y1	U 2	8
CC0	U 6	3
CC1	U 6	4
CC2	U 6	5
CC3	U 6	6



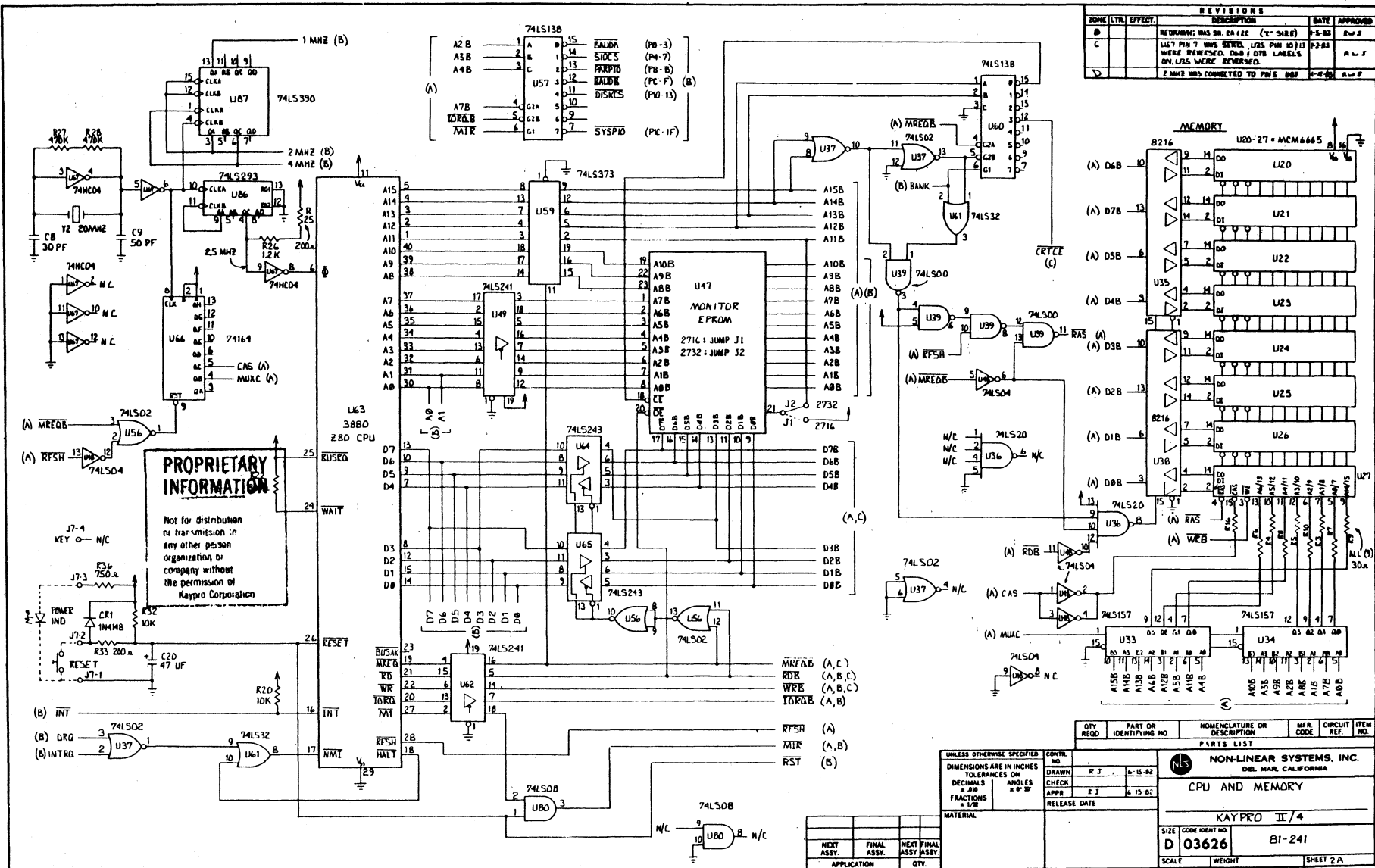

REVISIONS					
ZONE	LT/L	EFFECT	DESCRIPTION	DATE	APPROVED
B			RETURNING; HAS SR. ENTEE ('E' 24RE)	6-15-82	R.W.F
C			LET PIN 7 WMS SENSE, U25 PIN 10 J13 P248		R.W.F
D			WHERE RELEASED, COB / D78 LABELS ON L25 WERE REVERSE		
			2 MHz WMS CONNECTED TO PWS 687	6-15-82	R.W.F

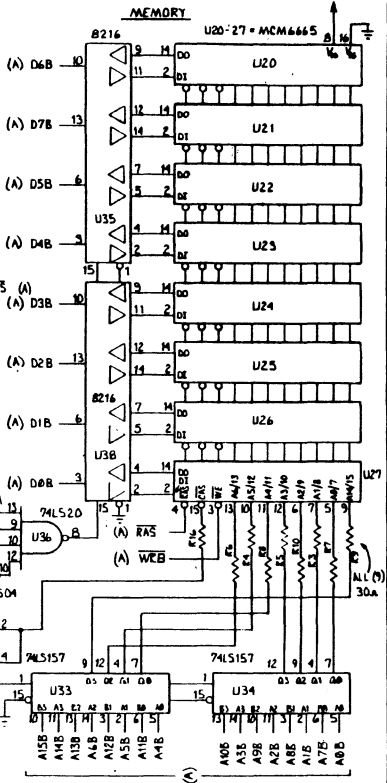

QTY	PART OR IDENTIFYING NO.	NOMENCLATURE OR DESCRIPTION	MFR. CODE	CIRCUIT REF.	ITEM NO.
PARTS LIST					
UNLESS OTHERWISE SPECIFIED: DIMENSIONS ARE IN INCHES TOLERANCES ON DECIMALS = .010 ANGLES = 90° APPR = 1/32 RELEASE DATE					
NON-LINEAR SYSTEMS, INC. DEL MAR, CALIFORNIA					
CPU AND MEMORY					
KAYPRO II/4					
SIZE CODE IDENT NO.		D 03626			
SCALE		WEIGHT		SHEET 2A	





6-16

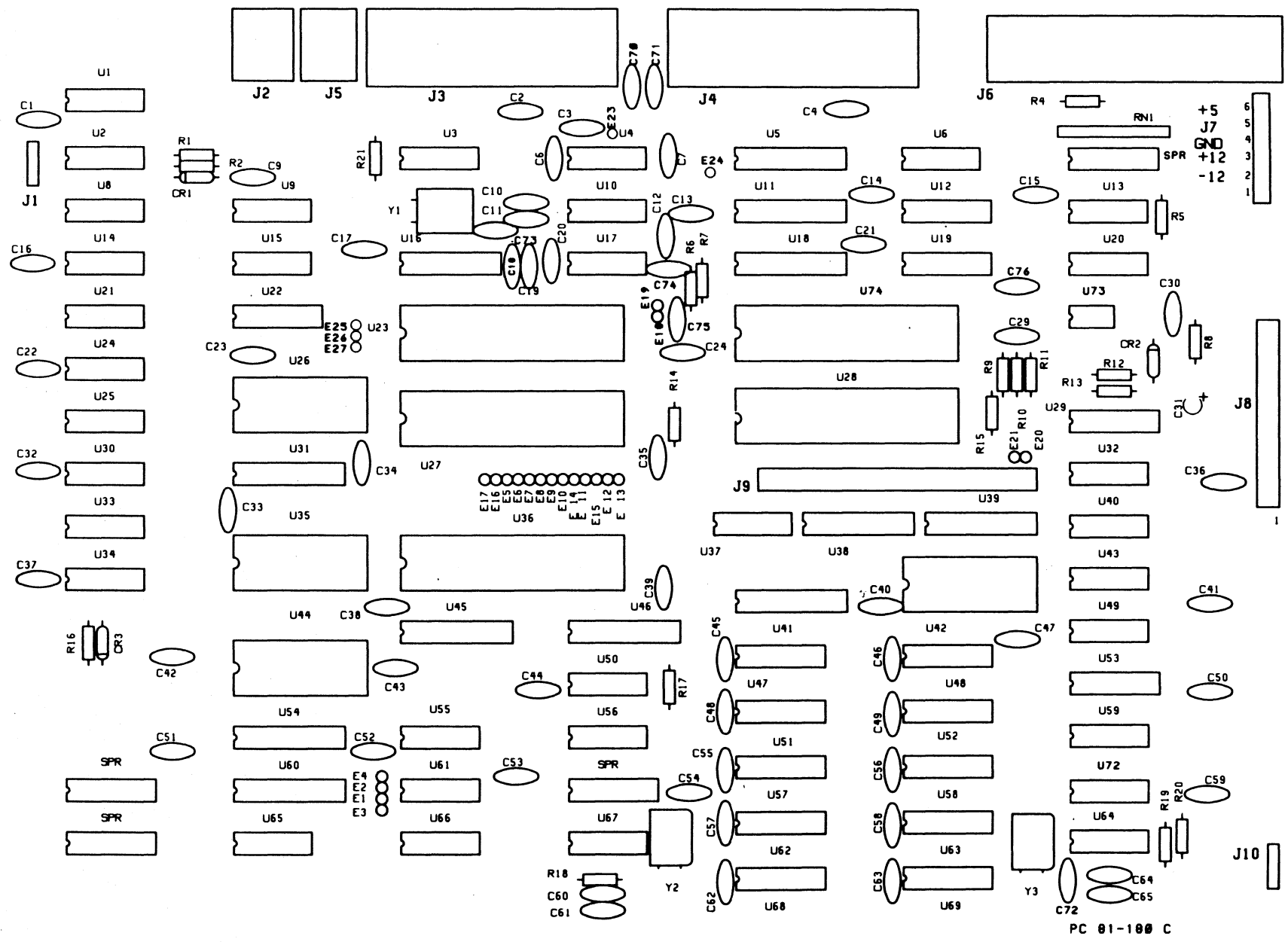

IC LIST, 81-180-n

Reference Designation		Description
U1	74S74	Dual "D" flip-flop
U2	74S08	Hex Schmitt Quad AND gate
U3	74S04	Hex inverter
U4, U10	1489	Quad SCHMITT line receiver
U5, U38, U41	74LS244	Octal buffer
U6, U21, U24, U33, U49	74LS74	Dual "D" flip-flop
U20, U30	74LS08	Quad AND gate
U8, U37, U50	74LS00	Quad NAND gate
U9, U59	74LS393	Dual binary counter
U11, U18, U31, U45, U46, U60	74LS373	Octal "D" latch
U12, U19	74LS138	3/8 MUX
U13	7406	Hex inverter, open collector
U14	74S86	Hex Schmitt Quad XOR gate
U15, U61	74S20	Dual NAND gate
U16	8116	Dual programmable baud rate generator
U17	1488	Quad transmitter
U22	74LS165	8-bit shift register
U23, U27	Z80A SIO	
U25, U72	74LS10	Tri NAND gate
U26	81-187	Character generator EPROM (2732)
U28	Z80A CPU	
U29	74LS195	4-bit shift register
U32, U43	74LS02	Quad NOR gate
U34	74LS14	Hex Schmitt inverter
U35, U44	6116	RAM, 2K x 8-bit (200ns)
U36	6545A-1	Video controller
U39, U54	74LS245	Bi-directional 8-bit buffer
U42	81-302-C	Boot EPROM (2732)
U40	74LS32	Quad OR gate
U47, U48	74LS157	Quad 2/1 MUX
U51, U52, U57, U58, U62, U63, U68, U69	4565N-15	Dynamic RAM 64K x 1 (150ns) (Mostek number)
U53	74LS163	Synchronous 4-bit binary counter
U55	14-2-392	14-Pin pull-up resistor
U56, U65	74LS04	Hex inverter
U64, U67	74HCU04	Hex inverter, CMOS
U66	74LS93	Asynchronous 4-bit binary counter
U73	WD9216	Data separator
U74	1793	Floppy disk controller

## SCOPE SIGNALS FOR TROUBLESHOOTING 81-180-n

The examples of correct signals shown here do not represent all of the signals on the 81-180-n mainboard, since most of the signals will be high-low toggles. A group of signals taken from a video clock divider (U66) are shown to illustrate the timing relationships between the various video signals.

The signal measurements were made using a Tektronix oscilloscope, model 2213. It has a bandwidth of DC-60 MHz, sensitivity of 2mV/cm, a sweep delay of 0.1 microseconds to 1 second, and a graticule display measuring 8 x 10 cm.

Each square of the representation is the equivalent of one square cm. on the graticule. The scope was set for 2V/div. and .2micro-secs/div. for all figures except figure 2, which was set at .5micro-secs/div.

Signal M1 from pin 27 of the CPU (U28) was triggered on. This signal is shown in the top half of each display and was channel 1. Ground for signals shown on channel 2 was established at the first graticule line above the bottom of the display.

State of the machine: The machine has just booted-up on the hard drive.

Figure 1: Pin 6 of U28, 4MHz clock signal:

Figure 2: Pin 24 of U74, 1MHz clock signal.

Figure 3: Pin 12 of U66, video, clock divider.

Figure 4: Pin 9 of U66, video, clock divider.

Figure 5: Pin 8 of U66, video, clock divider.

Figure 6: Pin 11 of U66, video, clock divider.

FIGURE 1

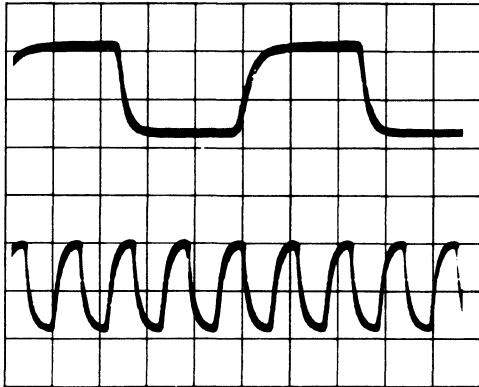

FIGURE 2

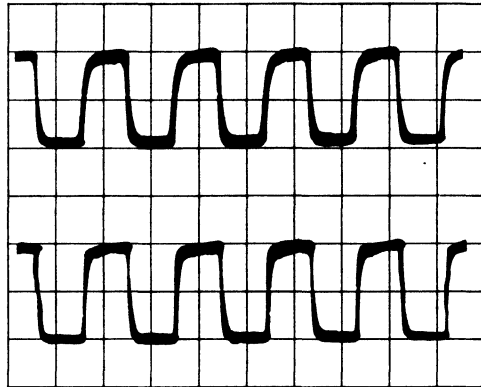

FIGURE 3

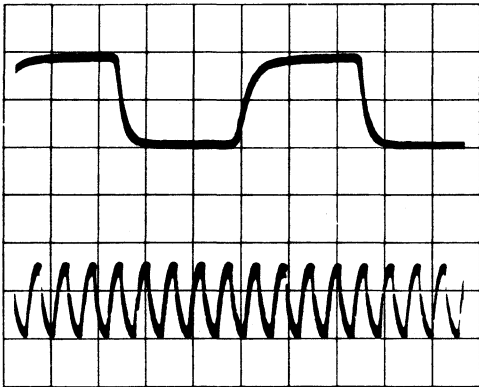

FIGURE 4

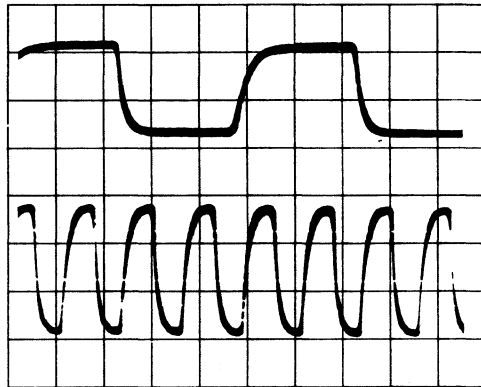

FIGURE 5

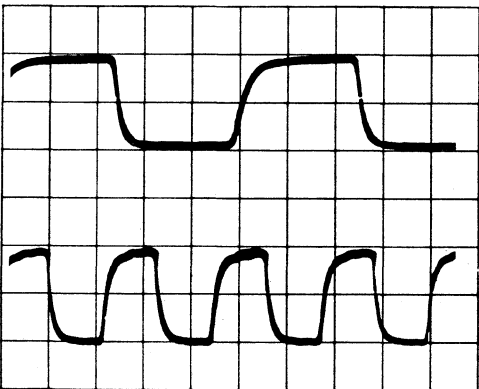
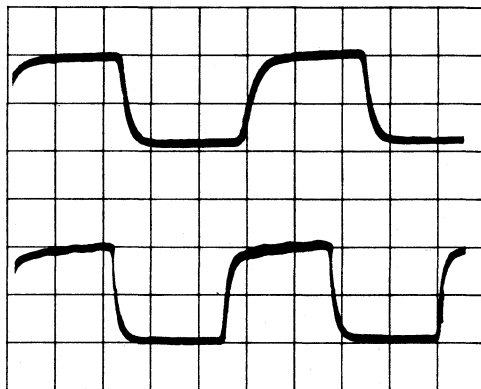
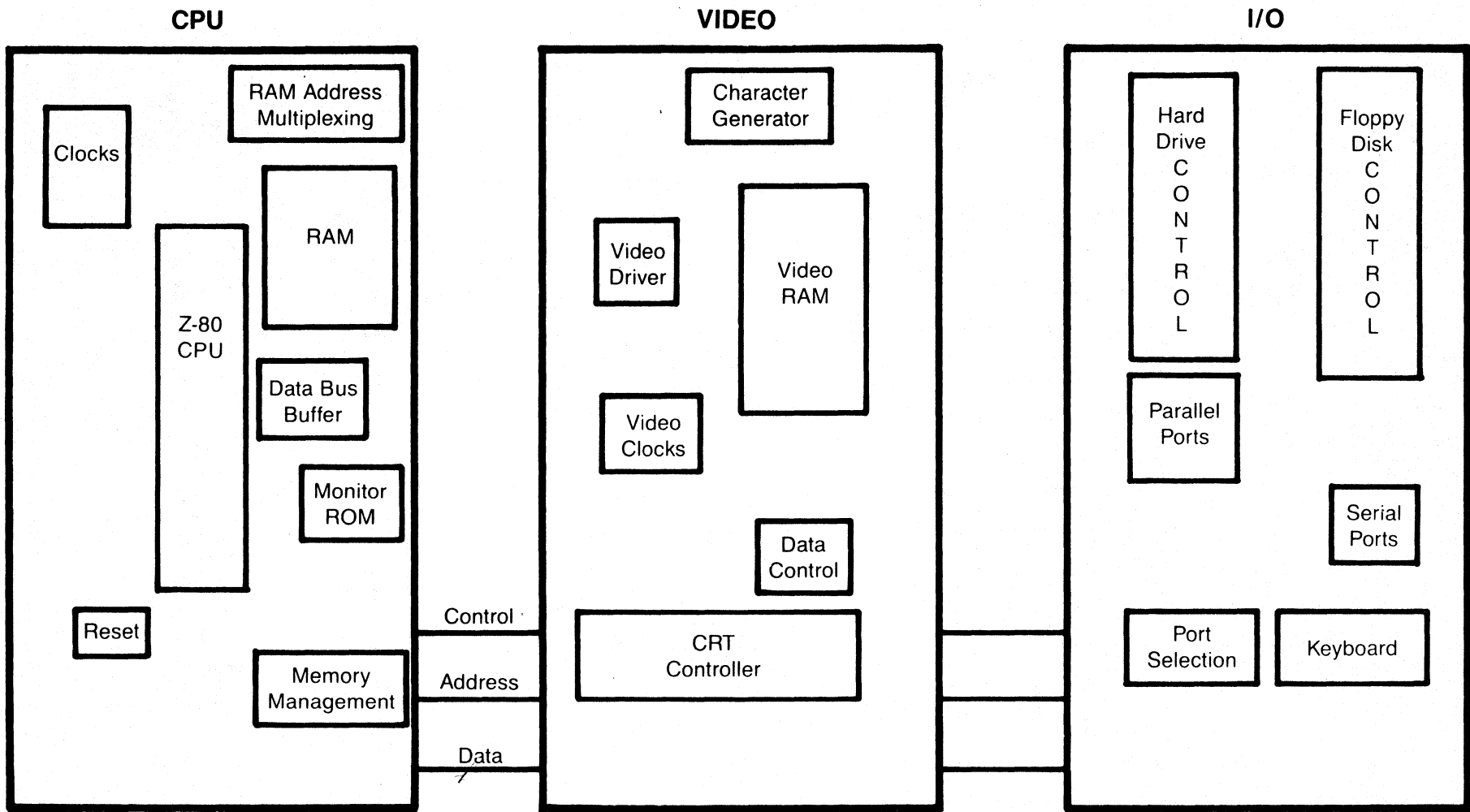

FIGURE 6





**KAYPRO 10 BLOCK DIAGRAM**







6-23

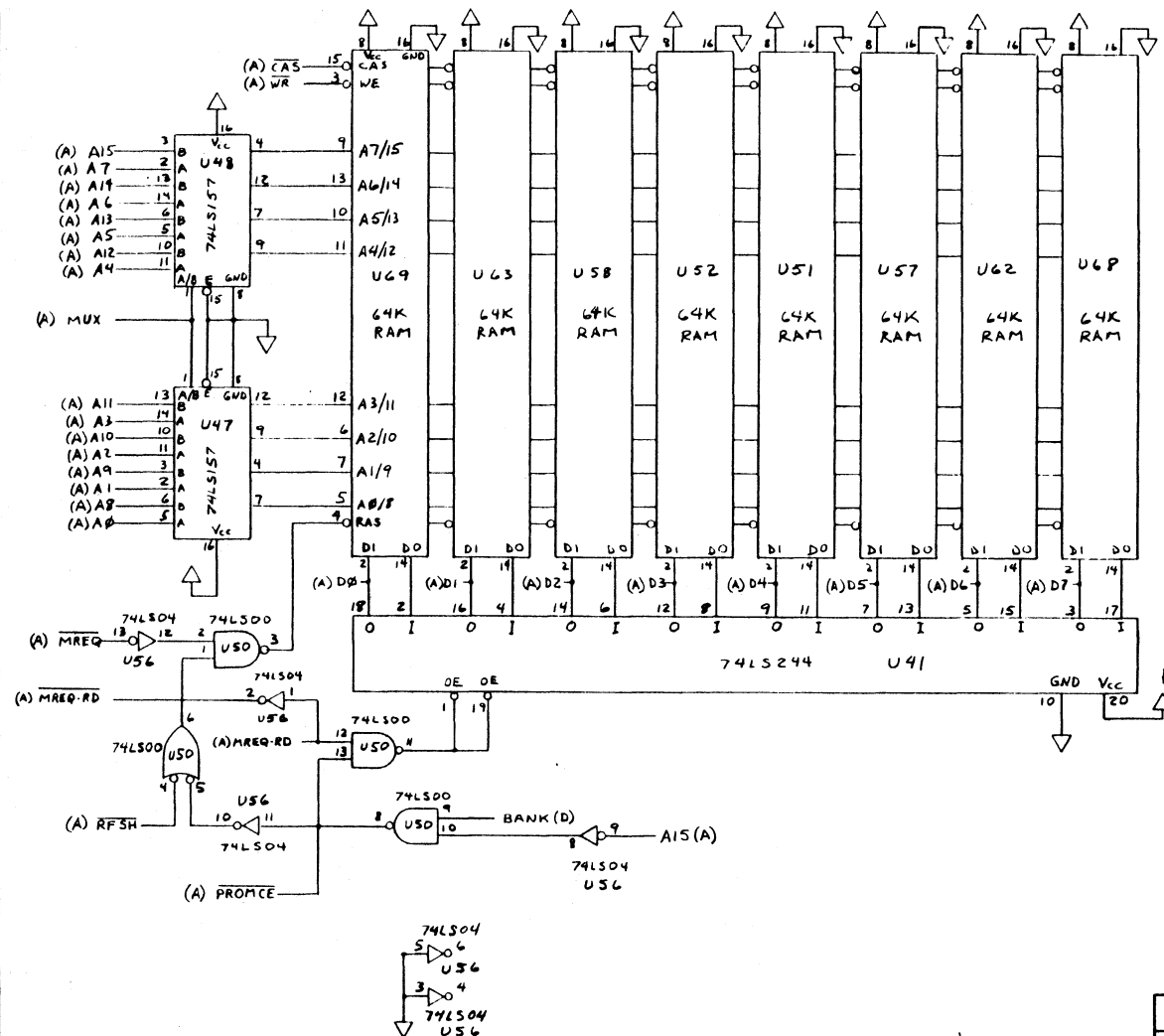

REVISIONS					
ZONE	LTR.	EFFECT.	DESCRIPTION	DATE	APPROVED
A	ALL		ADD COMM TO U47	12-78	AJ
B	1190N		REVISED SYMBOL NO.	2-79	RJ

UNOS USED:

**PROPRIETARY INFORMATION**  
 Not for distribution or transmission to any other person without the permission of Raytheon Corporation.

QTY REQD	PART OR IDENTIFYING NO.	NOMENCLATURE OR DESCRIPTION	MFR. CODE	CIRCUIT REF.	ITEM NO.
----------	-------------------------	-----------------------------	-----------	--------------	----------

PARTS LIST

UNLESS OTHERWISE SPECIFIED		CONTR. NO.
DIMENSIONS ARE IN INCHES		DRAWN R J 10-4-78
TOLERANCES ON		CHECK
DECIMALS ± .010	ANGLES ± 0° 30'	APPR R J 11-9-78
FRACTIONS ± 1/32		RELEASE DATE

NLS NON-LINEAR SYSTEMS, INC. DEL MAR, CALIFORNIA	
SCHEMATIC, RAM	
KAYPIRO 10	
SIZE C	CODE IDENT NO. 03626
SCALE	WEIGHT
SHEET 2 C	

NEXT ASSY.	FINAL ASSY.	NEXT FINAL ASSY.	FINAL ASSY.
APPLICATION	QTY.		

6-24

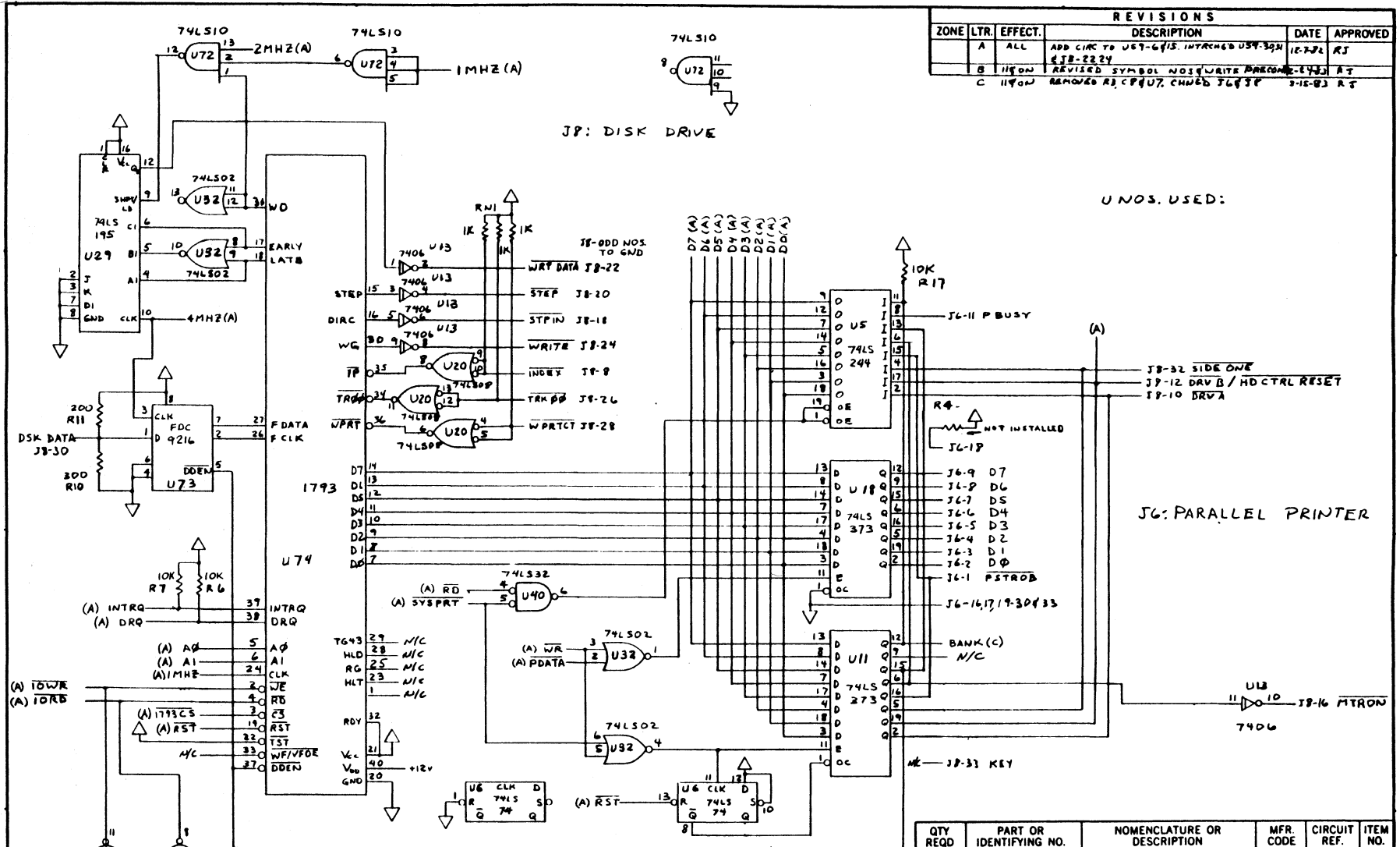

REVISIONS					
ZONE	LTR.	EFFECT.	DESCRIPTION	DATE	APPROVED
A	ALL		ADD CIRC TO U67-6/15. INTRACH 28 U54-30X	10-7-82	RT
B	115 ON		REVISED SYMBOL NOS WRITE PARALLEL 28-11 AT		
C	119 ON		REMOVED R3, C1, U7, CHANGES 36-138	3-15-83	RT

UNOS. USED:

QTY REQD	PART OR IDENTIFYING NO.	NOMENCLATURE OR DESCRIPTION	MFR. CODE	CIRCUIT REF.	ITEM NO.

PARTS LIST

**PROPRIETARY INFORMATION**

Not for distribution outside of the company without the permission of the company.

APPLICATION	QTY.
NEXT ASSY.	FINAL ASSY.
NEXT FINAL ASSY.	FINAL ASSY.

UNLESS OTHERWISE SPECIFIED  
 DIMENSIONS ARE IN INCHES  
 TOLERANCES ON DECIMALS ± .010  
 TOLERANCES ON FRACTIONS ± 1/32

CONTR. NO.	DATE
RJ	10-4-82
RS	12-9-82

**NLS** NON-LINEAR SYSTEMS, INC.  
 DEL MAR, CALIFORNIA

**SCHEMATIC FLOPPY CONTROL & PARALLEL PRINTER**  
**KAYPRO 10**

SIZE	CODE IDENT NO.	SCALE	WEIGHT	SHEET
C	03626			2 D
	81-181			

6-25

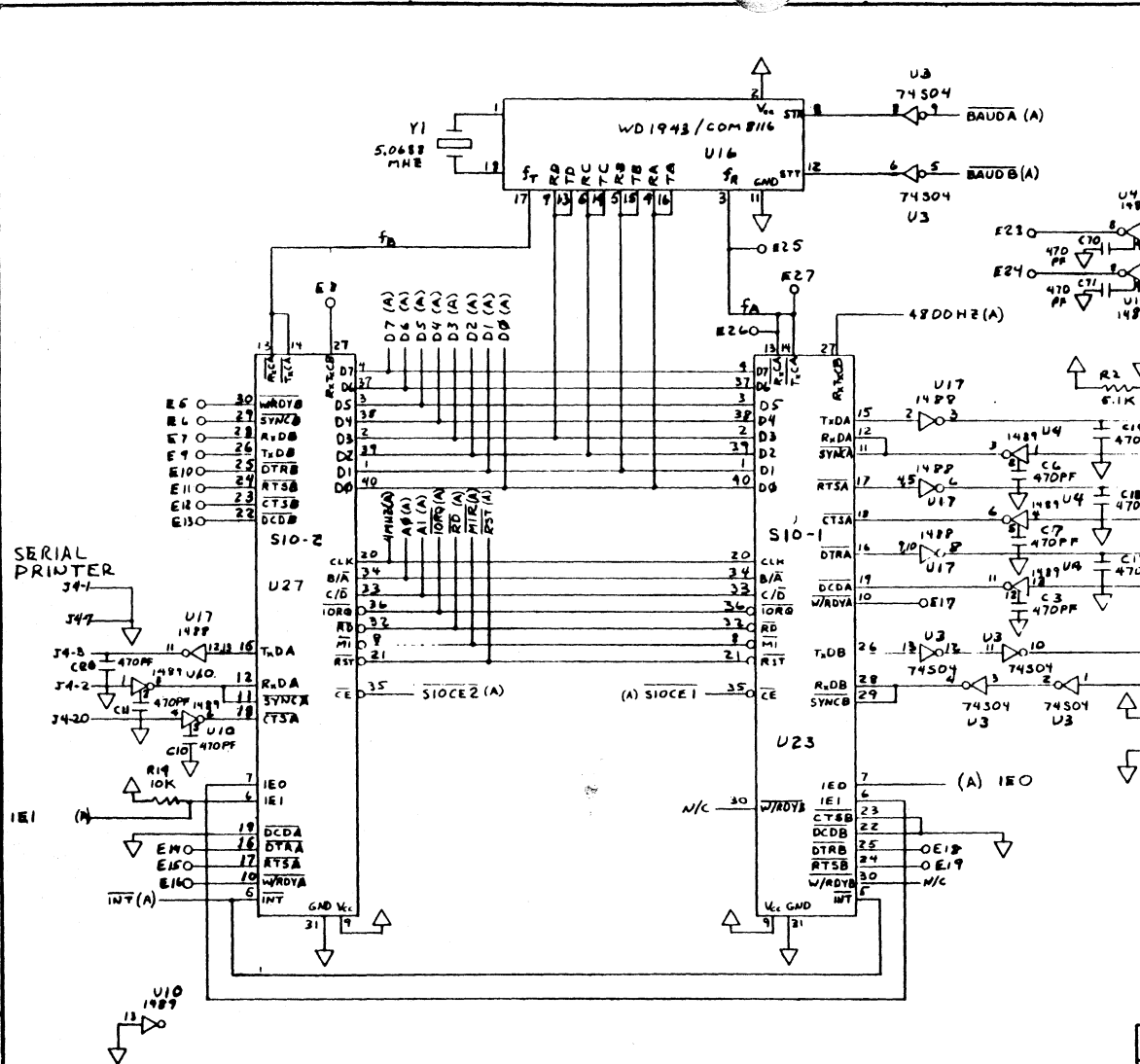

REVISIONS					
ZONE	LTR.	EFFECT.	DESCRIPTION	DATE	APPROVED
A	ALL		INTRCHG DB, D4, D2, D3 INTO U4	12-2-82	R J
B	1180N		INTENED AS A SECTION OF U3	12-2-82	R J
C	1180N		REVISED SYMBOL NOS.	12-2-82	R J
D	12180N		ADDED CONNECTIONS TO J3-15(17)	3-27-83	R J
D1	12180N		REMOVED J3-15(17)	6-27-83	R J

U NOS. USED:

MODEM

KEYBOARD

**PROPRIETARY INFORMATION**

Not for distribution or transmission to any other person, organization or company without the permission of Kaypro Corporation

QTY REQD	PART OR IDENTIFYING NO.	NOMENCLATURE OR DESCRIPTION	MFR. CODE	CIRCUIT REF.	ITEM NO.
----------	-------------------------	-----------------------------	-----------	--------------	----------

PARTS LIST

UNLESS OTHERWISE SPECIFIED		CONTR. NO.	
DIMENSIONS ARE IN INCHES		DRAWN	R J
TOLERANCES ON		CHECK	
DECIMALS	± .010	ANGLES	± 0° 30'
FRACTIONS	± 1/32	APPR	R J
		RELEASE DATE	12-5-82

**NLS NON-LINEAR SYSTEMS, INC.**  
DEL MAR, CALIFORNIA

**SCHEMATIC, SERIAL PORTS**

**KAYPRO 10**

SIZE CODE IDENT NO. **C 03626** 81-181

SCALE WEIGHT SHEET **2E**

NEXT ASSY.	FINAL ASSY.	NEXT FINAL ASSY.	APPLICATION	QTY.

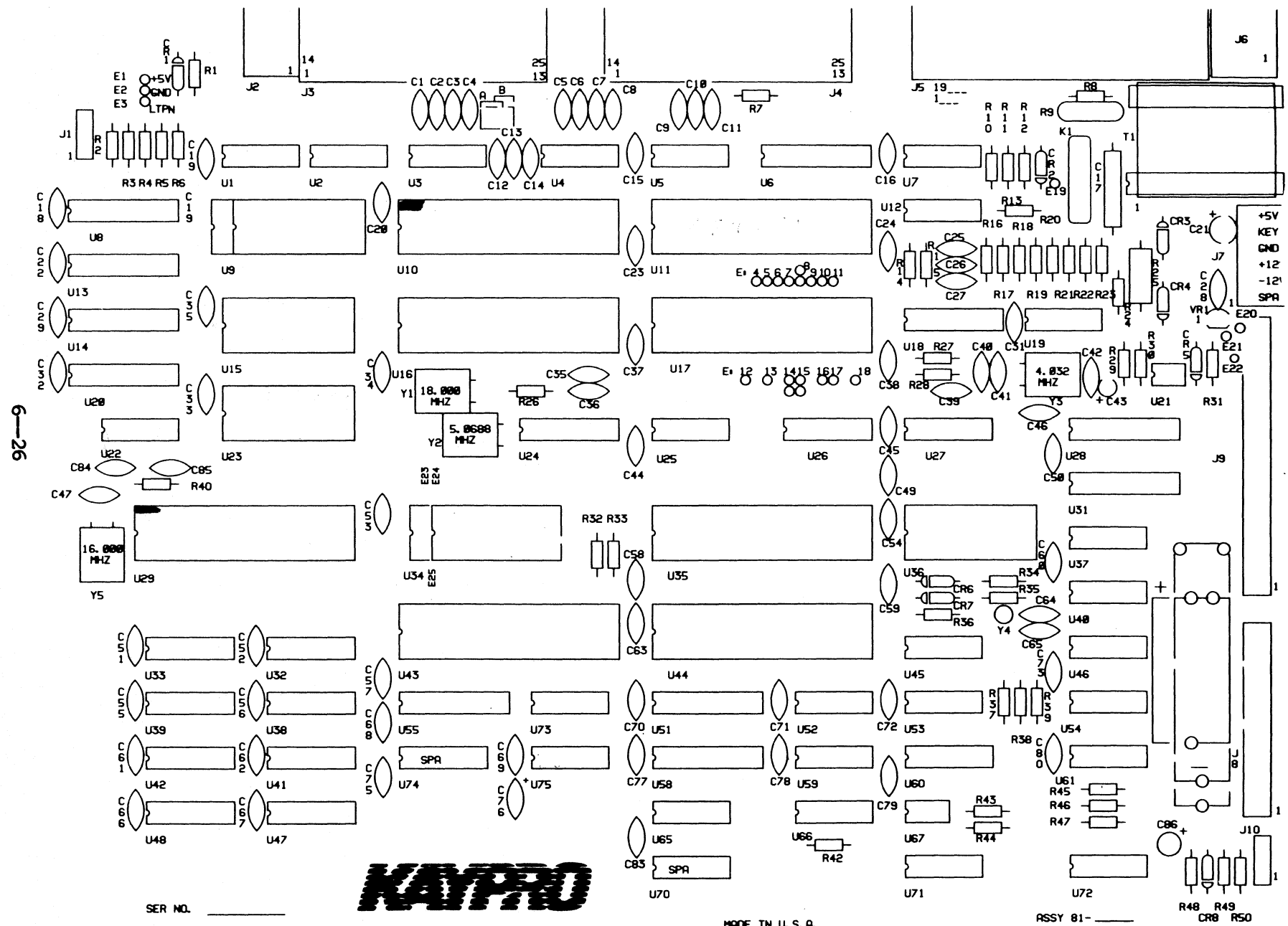

6-26

SER. NO. \_\_\_\_\_



MADE IN U.S.A.

ASSY 81- \_\_\_\_\_

R48 R49 CR8 R50

# IC LIST, 81-294-n

Reference Designation		Description
U1, U54	7406	Hex inverter, open collector
U2, U25, U71	74LS14	Hex Schmitt inverter
U3, U5	1489	Quad Schmitt line driver
U4	1488	Quad line driver
U6, U13, U14, U55, U58	74LS373	Octal "D" latch
U8	74LS374	Octal "D" flip-flop
U9	81-235-n	Character PROM (2732)
<del>U10</del>	81-189	Custom gate array
U11, U17	Z80 SIO	
U15, U23	6116	Video RAM
U16	6545EA	CRT controller
U20, U31	74LS245	Octal bus transceiver
U22	3.9K	Pull-up Resistor
U24	WD1943/ 8116	Dual programmable baud rate generator
U26, U27	74LS138	3/8 MUX
U28, U51	74LS244	Octal buffer/line driver (3-state outputs)
<del>U29</del>	81-194	Custom gate array
U32, U33, U38, U39, U41, U42, U47, U48	2164	64K x 1 RAM
U34	81-292	Boot PROM (2764)
U37, U45, U59, U72	74LS02	Quad NOR gate
U40	74LS00	Quad NAND gate
U43	Z80A CPU	
U44	1793	Floppy disk controller
U46	74LS04	Hex inverter
U52	74LS32	Quad OR gate
U60	74LS195	4-bit shift register
U61	74LS08	Quad AND gate
U65	74LS10	Tri NAND gate
U66, U75	74LS74	Dual "D" flip-flop
U67	FDC9216	Data separator
U73	74HC00	Quad NAND gate

**SCOPE SIGNALS, 81-294-n**

**\*\*\*\*\***

Scope signals for this mainboard will be available soon; the section will be sent to the dealers for insertion into the new Technical Reference Manual as soon as it is available.

**\*\*\*\*\***



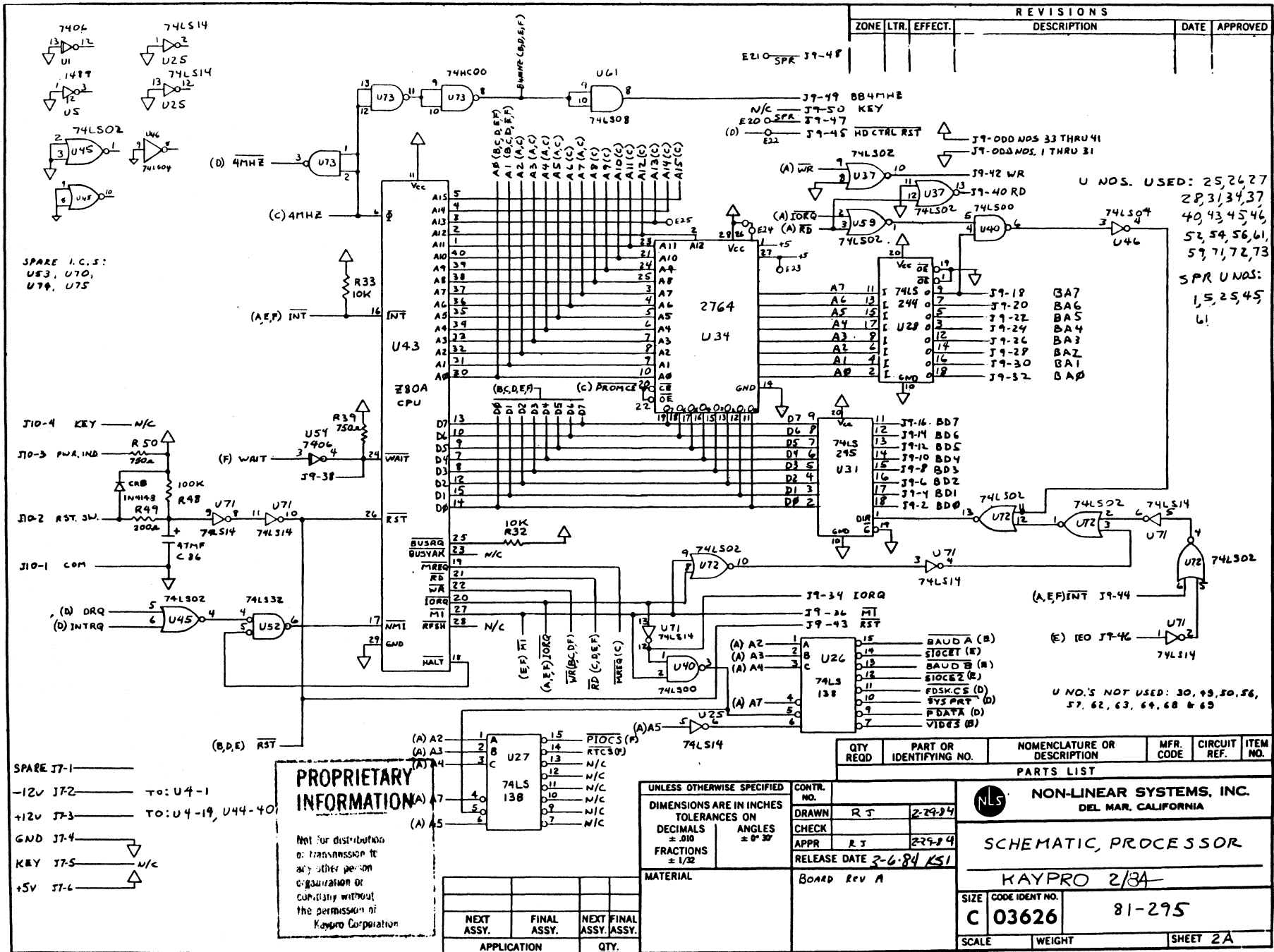

REVISIONS					
ZONE	LTR.	EFFECT.	DESCRIPTION	DATE	APPROVED

U NOS. USED: 25, 24, 27, 28, 31, 34, 37, 40, 43, 45, 46, 52, 54, 56, 61, 59, 71, 72, 73

SPR UNOS: 1, 5, 25, 45, 61

SPARE I.C.'S:  
U63, U70,  
U74, U75

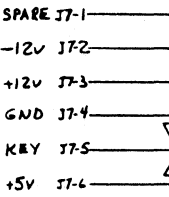
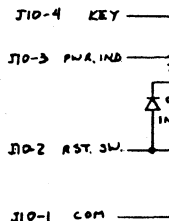

**PROPRIETARY INFORMATION**

Not for distribution or transmission to any other person or organization or copy without the permission of Kaypro Corporation

QTY REQD	PART OR IDENTIFYING NO.	NOMENCLATURE OR DESCRIPTION	MFR. CODE	CIRCUIT REF.	ITEM NO.

UNLESS OTHERWISE SPECIFIED		CONTR. NO.	
DIMENSIONS ARE IN INCHES		DRAWN	R J
TOLERANCES ON		CHECK	
DECIMALS ±.010	ANGLES ±0°30'	APPR	R J
FRACTIONS ±1/32		RELEASE DATE	3-6-84 KSI

**NON-LINEAR SYSTEMS, INC.**  
DEL MAR, CALIFORNIA

**SCHMATIC, PROCESSOR**

KAYPRO 2/3A

SIZE: C CODE IDENT NO. 03626 81-295

SCALE: SHEET 2A

MATERIAL	BOARD REV A
NEXT ASSY.	
FINAL ASSY.	
NEXT FINAL ASSY.	
APPLICATION	QTY.

6-30

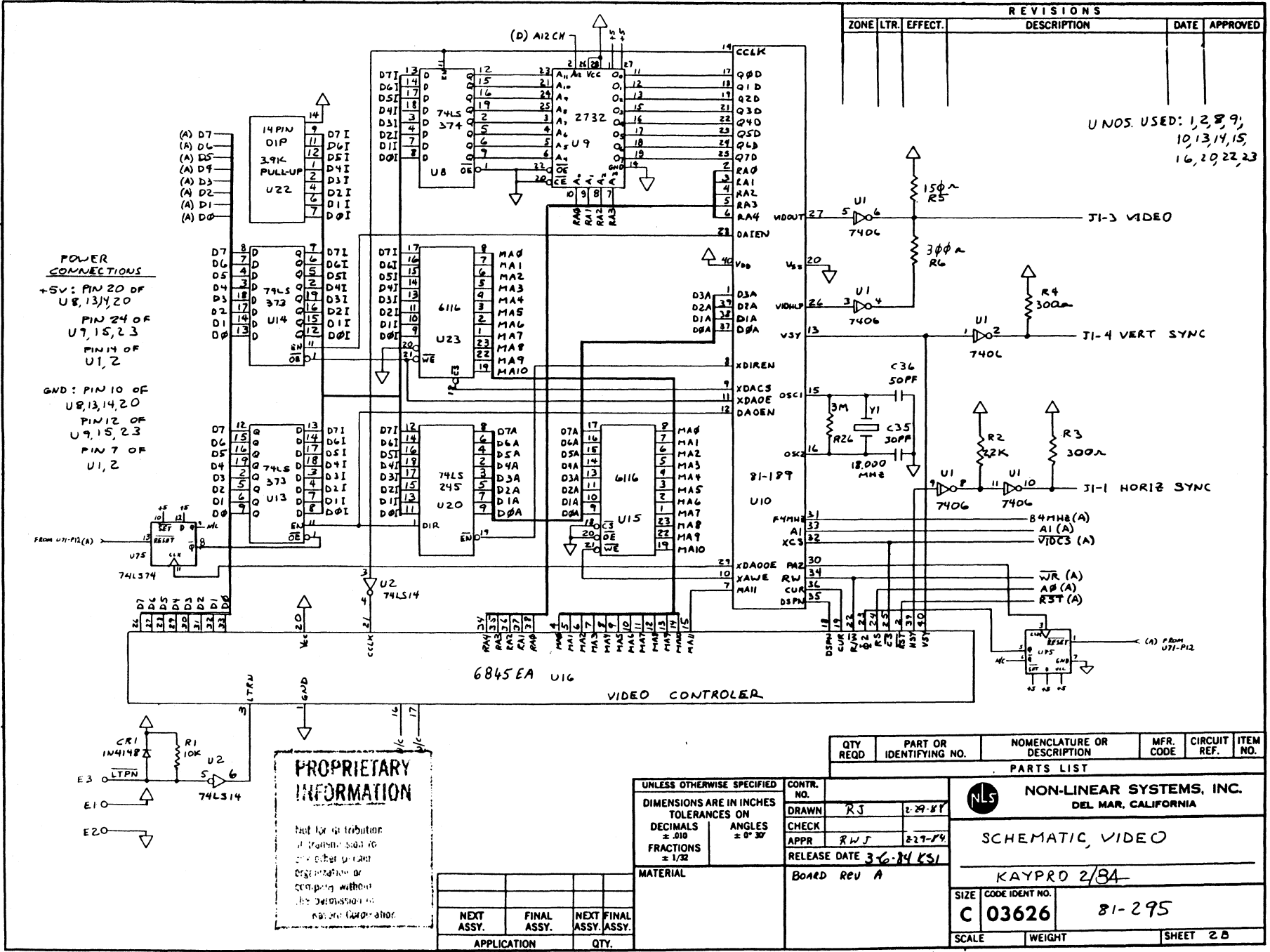

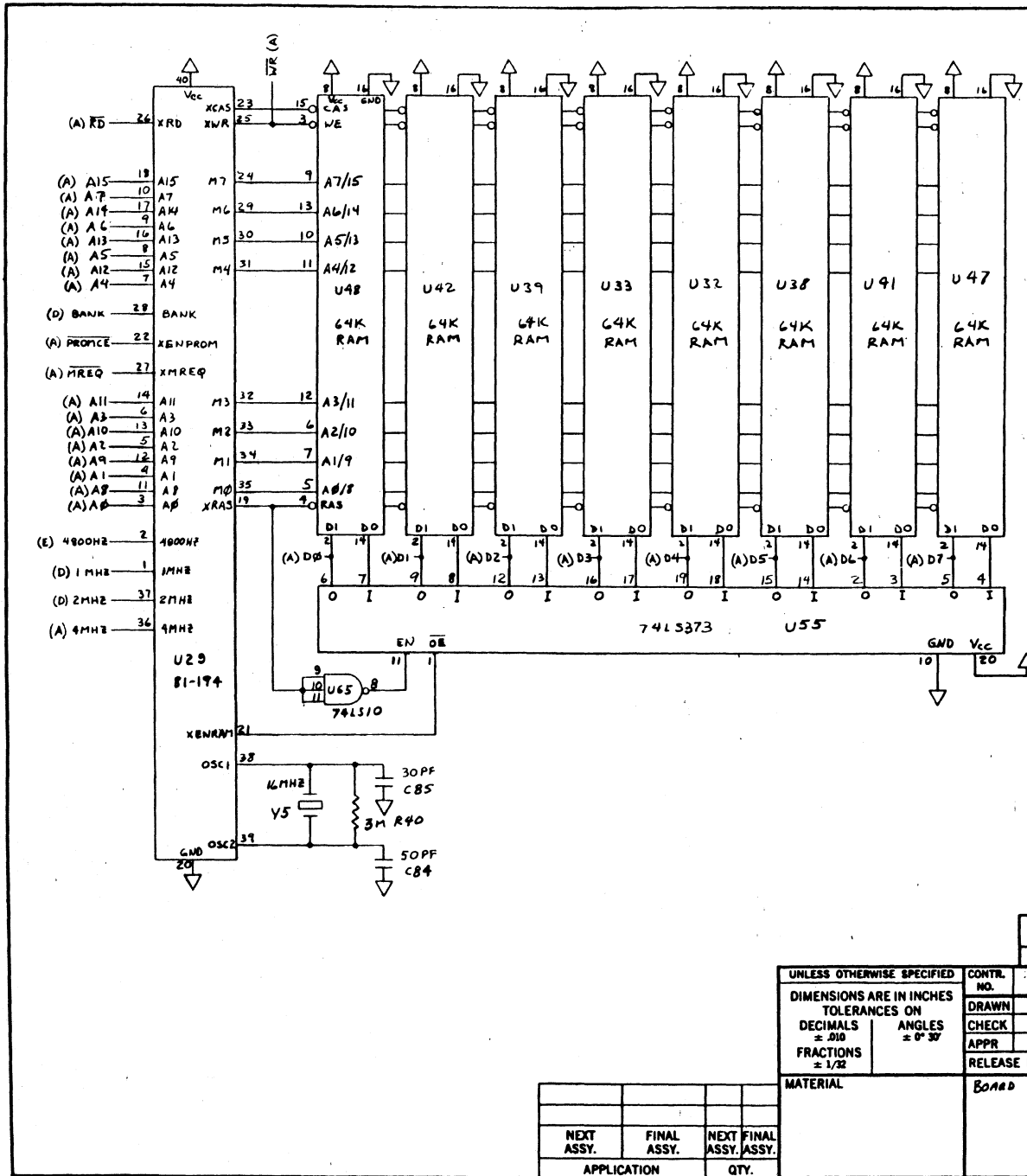

REVISIONS					
ZONE	LTR.	EFFECT.	DESCRIPTION	DATE	APPROVED

UNOS USED: 29, 48, 42,  
39, 33, 32, 38, 41, 47, 55,  
65

**PROPRIETARY INFORMATION**

Not for distribution or transmission to any other person or organization or company without the permission of Kaypro Corporation

QTY REQD	PART OR IDENTIFYING NO.	NOMENCLATURE OR DESCRIPTION	MFR. CODE	CIRCUIT REF.	ITEM NO.
----------	-------------------------	-----------------------------	-----------	--------------	----------

PARTS LIST

UNLESS OTHERWISE SPECIFIED		CONTR. NO.
DIMENSIONS ARE IN INCHES		DRAWN 2 J 2-29-84
TOLERANCES ON		CHECK
DECIMALS ± .010	ANGLES ± 0° 30'	APPR 2 J 2-29-84
FRACTIONS ± 1/32		RELEASE DATE 3-6-84 KSI
MATERIAL	BOARD REV A	

NLS NON-LINEAR SYSTEMS, INC. DEL MAR, CALIFORNIA	
SCHEMATIC, RAM	
KAYPRO 2/84	
SIZE C	CODE IDENT NO. 03626
SCALE	WEIGHT
SHEET 2 C	

APPLICATION	QTY.
NEXT ASSY.	FINAL ASSY.
NEXT FINAL ASSY.	

6-32

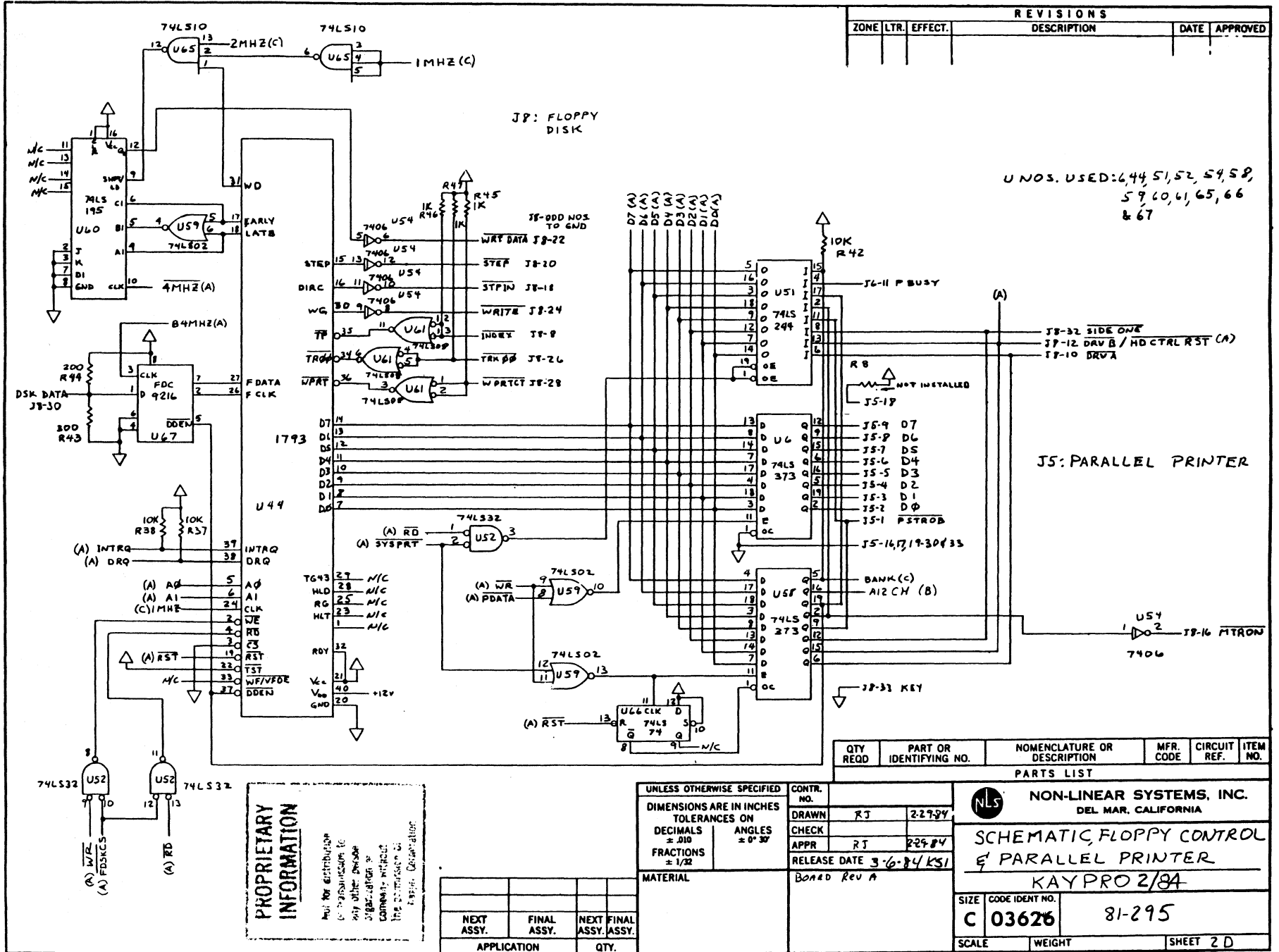

REVISIONS					
ZONE	LTR.	EFFECT.	DESCRIPTION	DATE	APPROVED

U NOS. USED: 6, 4, 5, 1, 5, 2, 5, 4, 5, 8,  
5, 9, 6, 0, 6, 1, 6, 5, 6, 6  
& 67

J5: PARALLEL PRINTER

**PROPRIETARY INFORMATION**  
 Not for distribution  
 or transmission to  
 any other source  
 without written  
 consent of  
 the Director of  
 Defense Organization

APPLICATION	QTY.

UNLESS OTHERWISE SPECIFIED	
DIMENSIONS ARE IN INCHES	CONTR. NO.
TOLERANCES ON	DRAWN RJ 2-2797
DECIMALS ± .010	CHECK
ANGLES ± 0° 30'	APPR RJ 2-2984
FRACTIONS ± 1/32	RELEASE DATE 3-6-84 KSI
MATERIAL	BOARD REV A

QTY REQD	PART OR IDENTIFYING NO.	NOMENCLATURE OR DESCRIPTION	MFR. CODE	CIRCUIT REF.	ITEM NO.
PARTS LIST					
NON-LINEAR SYSTEMS, INC. DEL MAR, CALIFORNIA					
SCHEMATIC FLOPPY CONTROL & PARALLEL PRINTER KAYPRO 2/84					
SIZE	CODE IDENT NO.	81-295			
C	03626				
SCALE	WEIGHT	SHEET 2 D			

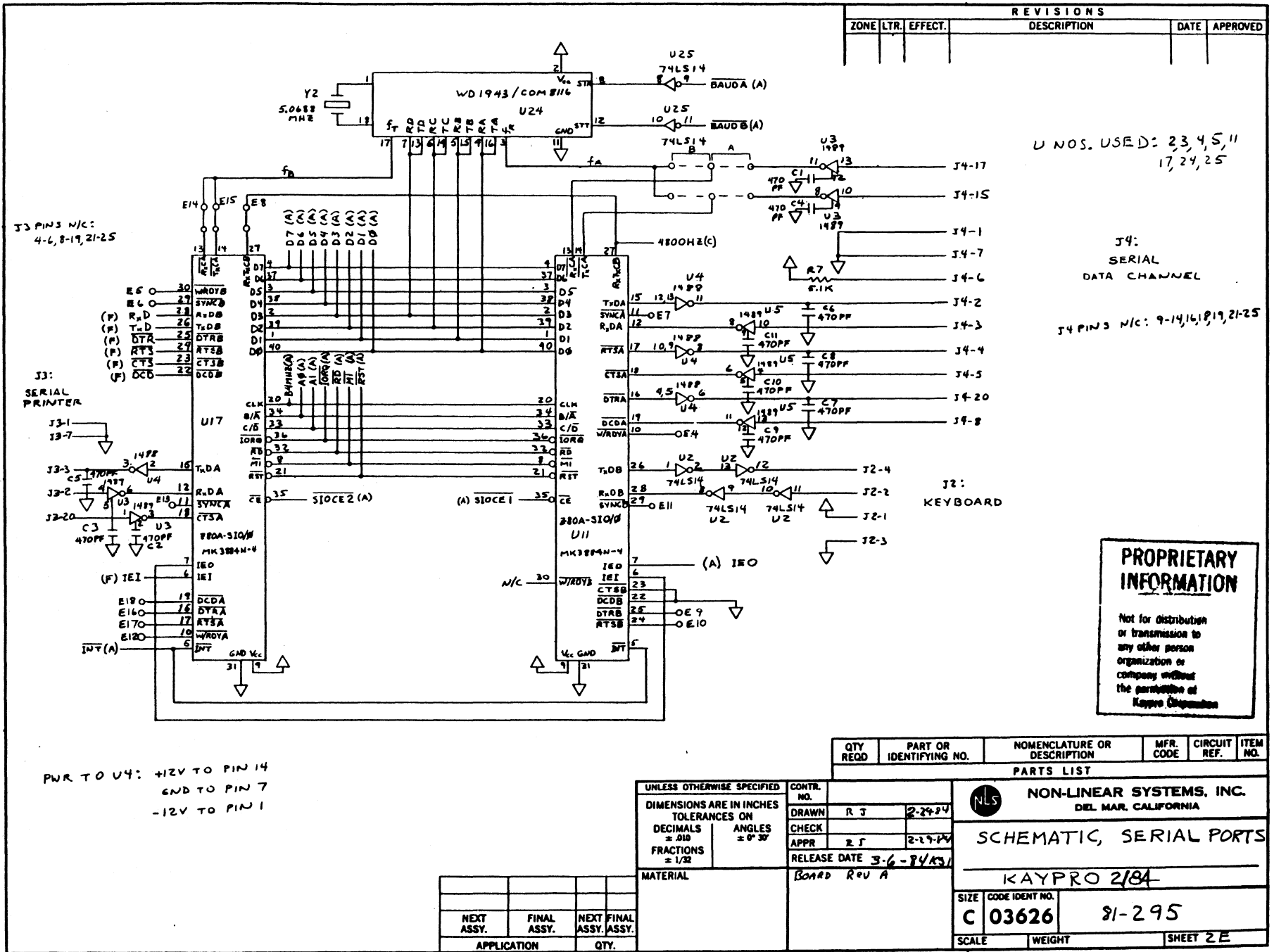

REVISIONS					
ZONE	LTR.	EFFECT.	DESCRIPTION	DATE	APPROVED

U NOS. USED: 2,3,4,5,11  
17,24,25

J4:  
SERIAL  
DATA CHANNEL

J4 PINS N/C: 9-14,16,19,21-25

J2:  
KEYBOARD

J3 PINS N/C:  
4-6,8-19,21-25

J3:  
SERIAL PRINTER

PWR TO U4: +12V TO PIN 14  
GND TO PIN 7  
-12V TO PIN 1

**PROPRIETARY INFORMATION**

Not for distribution or transmission to any other person organization or company without the permission of Kaypro Corporation

QTY REQD	PART OR IDENTIFYING NO.	NOMENCLATURE OR DESCRIPTION	MFR. CODE	CIRCUIT REF.	ITEM NO.
----------	-------------------------	-----------------------------	-----------	--------------	----------

**PARTS LIST**

NON-LINEAR SYSTEMS, INC.  
DEL MAR, CALIFORNIA

UNLESS OTHERWISE SPECIFIED		CONTR. NO.	
DIMENSIONS ARE IN INCHES		DRAWN	R J
TOLERANCES ON		CHECK	
DECIMALS	± .010	APPR	R J
ANGLES	± 0° 30'	RELEASE DATE	3-6-84/RJ
FRACTIONS	± 1/32		
MATERIAL			BOARD REV A

**SCHEMATIC, SERIAL PORTS**

KAYPRO 2184

APPLICATION	QTY.
NEXT ASSY.	FINAL ASSY.
NEXT FINAL ASSY.	

SIZE	CODE IDENT NO.	
C	03626	81-295
SCALE	WEIGHT	SHEET 2E

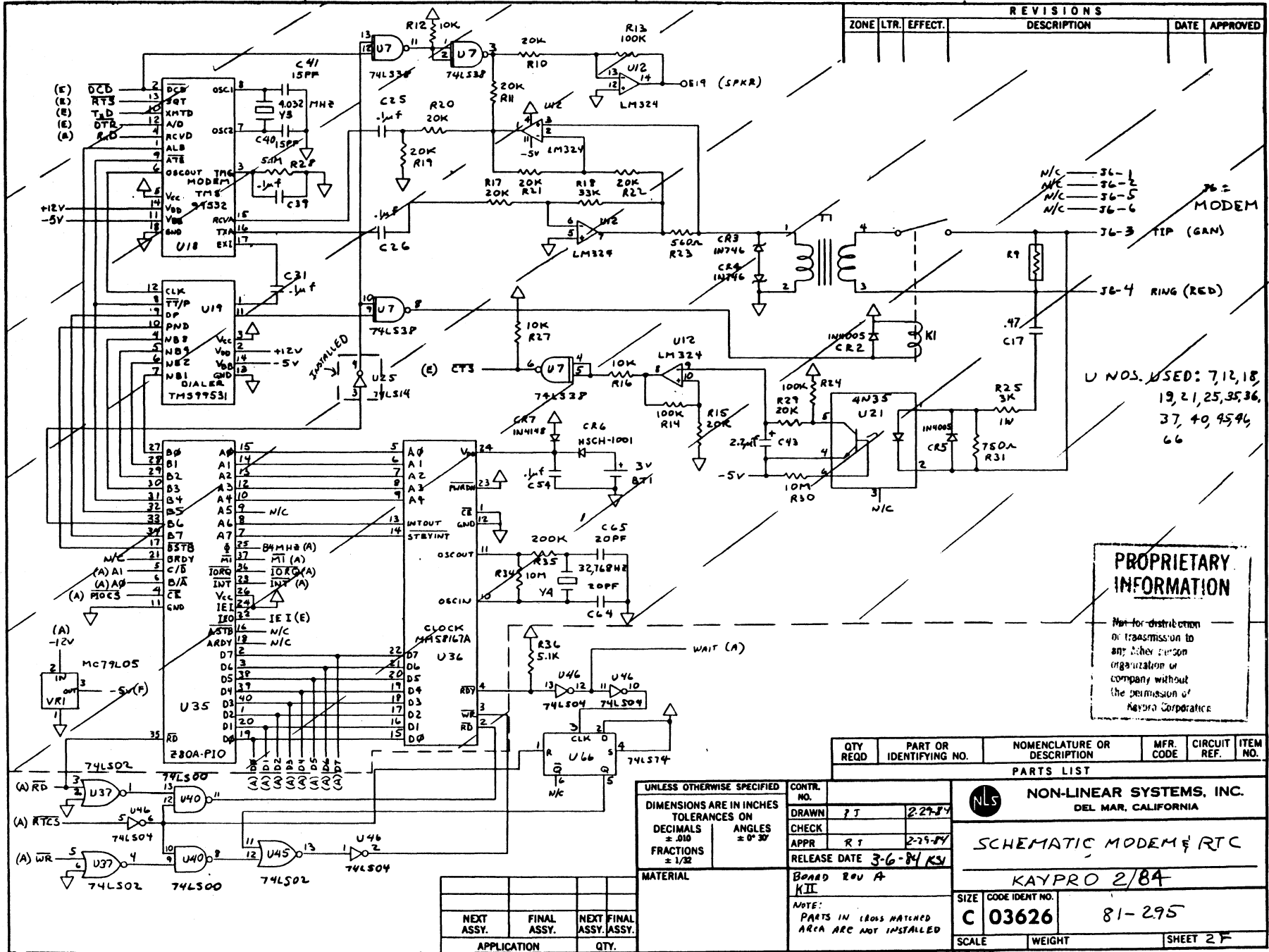

REVISIONS					
ZONE	LTR.	EFFECT.	DESCRIPTION	DATE	APPROVED

N/C = 36-1  
 N/C = 36-2  
 N/C = 36-5  
 N/C = 36-6

36-3 TIP (GAM)  
 36-4 RING (RED)  
 U NOS. USED: 7, 12, 18,  
 19, 21, 25, 35, 36,  
 37, 40, 45, 46,  
 66

**PROPRIETARY INFORMATION**  
 Not for distribution or transmission to any other person, organization or company without the permission of Narda Corporation.

QTY REQD	PART OR IDENTIFYING NO.	NOMENCLATURE OR DESCRIPTION	MFR. CODE	CIRCUIT REF.	ITEM NO.

PARTS LIST		NON-LINEAR SYSTEMS, INC. DEL MAR, CALIFORNIA	
UNLESS OTHERWISE SPECIFIED		CONTR. NO.	2-27-84
DIMENSIONS ARE IN INCHES		DRAWN	JT
TOLERANCES ON		CHECK	
DECIMALS		APPR	RT
± .010		RELEASE DATE	3-6-84 KSI
ANGLES		BOARD REV A	
± 0° 30'		KII	
FRACTIONS		NOTE:	
± 1/32		PARTS IN CROSS HATCHED AREA ARE NOT INSTALLED	
MATERIAL		SIZE	CODE IDENT NO.
		C	03626
			81-295
		SCALE	WEIGHT
			SHEET 2 F

APPLICATION	QTY.

6.5 KAYPRO 4/84 MAINBOARD (81-184-n)

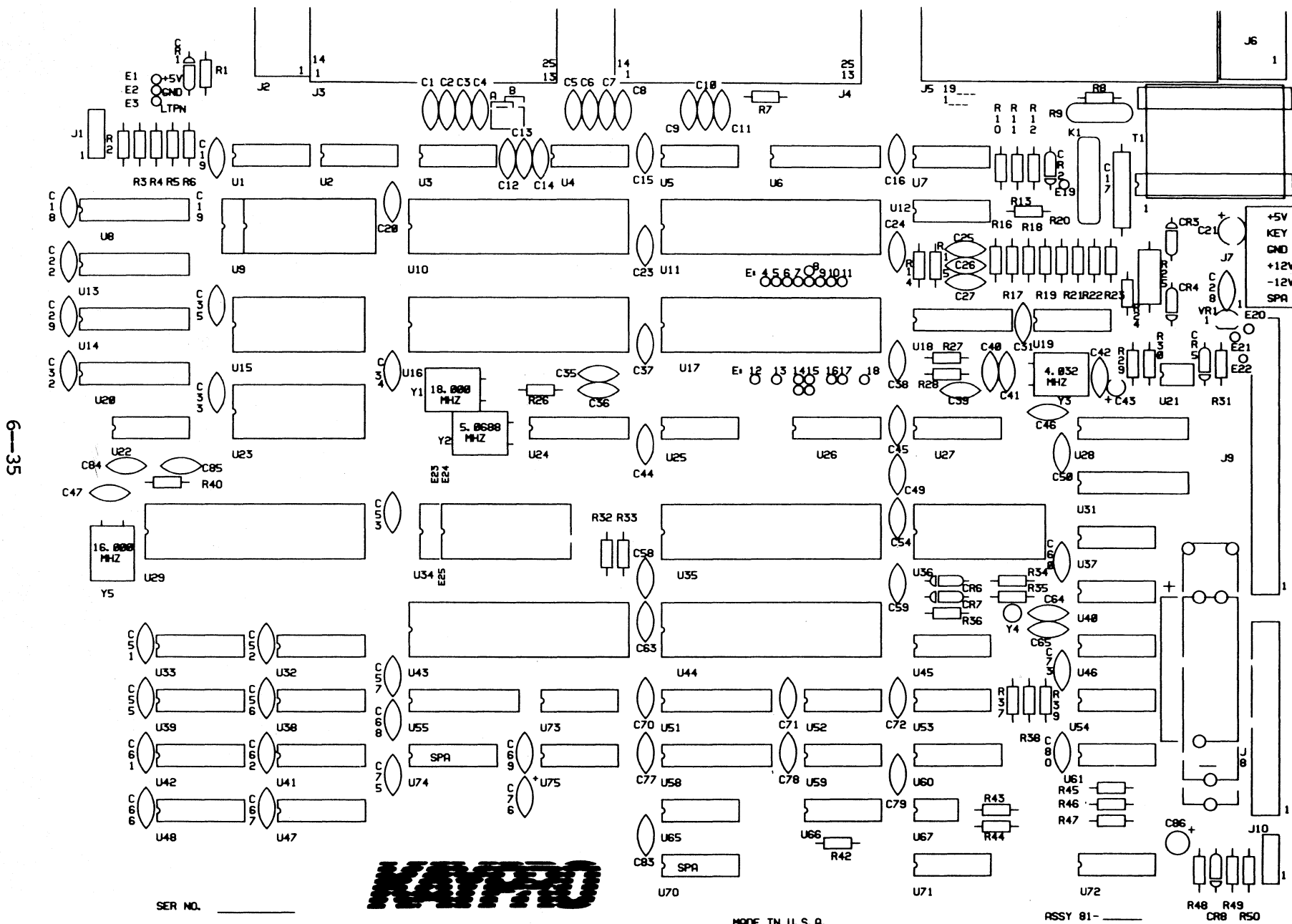

6-35

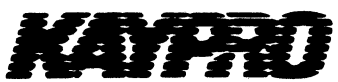

SER. NO. \_\_\_\_\_

MADE IN U. S. A.

ASSY 81- \_\_\_\_\_

R48 R49  
CR8 R50

## IC LIST, 81-184-n

Reference Designation		Description
U1, U54	7406	Hex inverter, open collector
U2, U25, U71	74LS14	Hex Schmitt inverter
U3, U5	1489	Quad Schmitt line driver
U4	1488	Quad line driver
U6, U13, U14, U55, U58	74LS373	Octal "D" latch
U7	74LS38	Positive-NAND buffer
U8	74LS374	Octal "D" flip-flop
U9	81-235	Character PROM (2732)
U10	81-189	Custom gate array
U11, U17	Z80A SIO	
U12	LM324	Op-Amp
U15, U23	6116	Video RAM
U16	6545A	Video controller
U18	TMS 99532	Modem
U19	TMS 99531	Dialer
U20, U31	74LS245	Octal bus transceiver (3-state outputs)
U21	4N35	Photo isolator
U22	3.9K	Pullup resistor, 14-pin DIP
U24	WD1943/ 8116	Dual programmable baud rate generator
U26, U27	74LS138	3/8 MUX
U28, U51	74LS244	Octal buffer/line driver
U29	81-194	Custom gate array
U32, U33, U38, U39, U41, U42, U47, U48	2164	64K x 1 RAM
U34	81-292	Boot PROM (2764)
U35	Z80A PIO	
U36	MM581678	Clock
U37, U45, U59, U72	74LS02	Quad NOR gate
U40	74LS00	Quad NAND gate
U43	Z80A CPU	
U44	1793	Floppy disk controller
U46	74LS04	Hex inverter
U52	74LS32	Quad OR gate
U53, U70, U74, U75		Spares
U60	74LS195	4-bit shift register
U61	74LS08	Quad AND gate
U65	74LS10	Tri NAND gate
U66, U75	74LS74	Dual "D" flip-flop
U67	FDC9216	Data separator
U73	74HC00	Quad NAND gate



**SCOPE SIGNALS, 81-184-n**

**\*\*\*\*\***

Scope signals for this mainboard will be available soon; the section will be sent to the dealers for insertion into the new Technical Reference Manual as soon as it is available.

**\*\*\*\*\***



**POWER CONNECTIONS**  
 +5V: PIN 20 OF U8, 13, 14, 20  
 PIN 24 OF U9, 15, 23  
 PIN 14 OF U1, 2  
 GND: PIN 10 OF U8, 13, 14, 20  
 PIN 12 OF U9, 15, 23  
 PIN 7 OF U1, 2

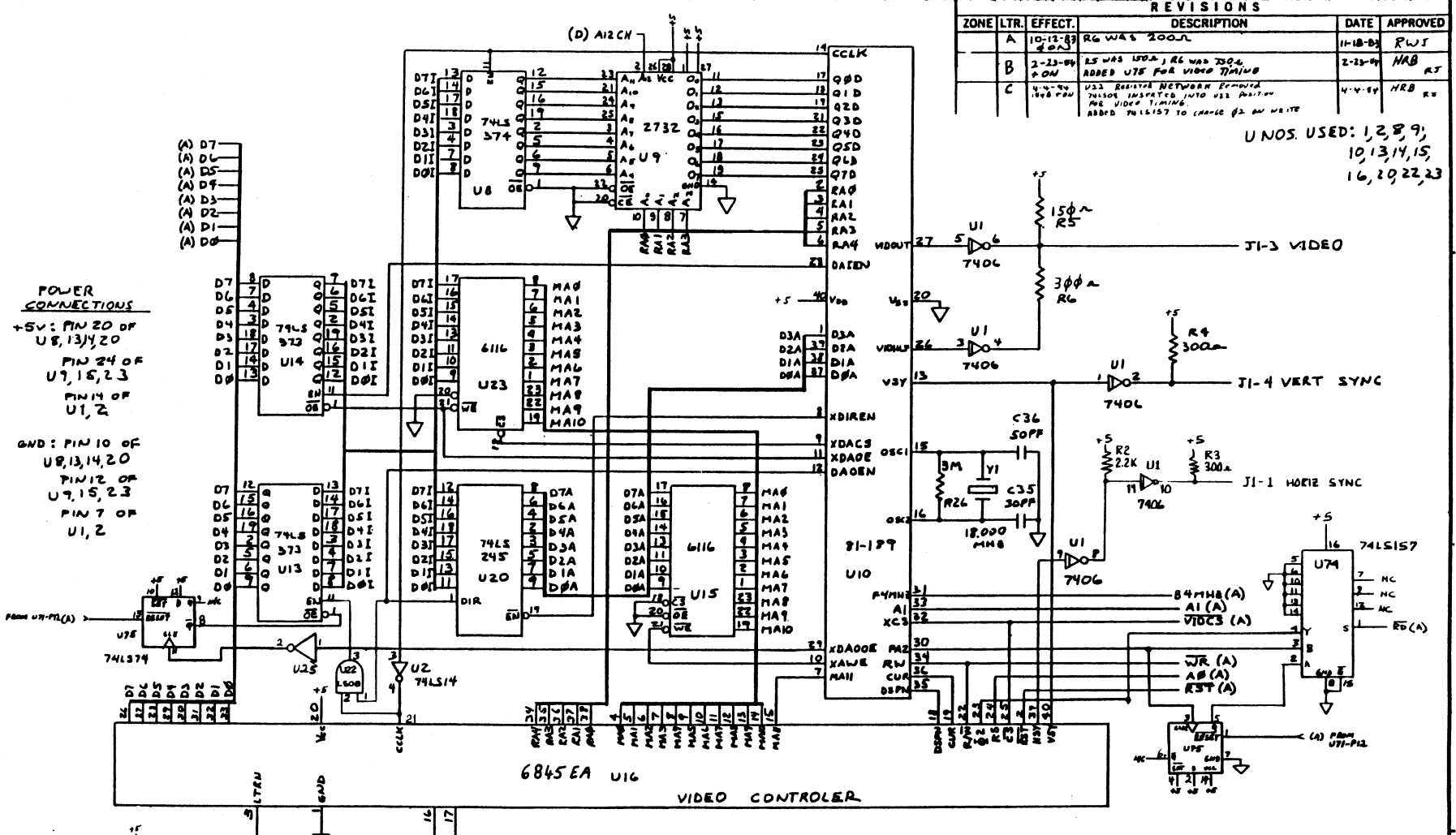

REVISIONS					
ZONE	LTR.	EFFECT.	DESCRIPTION	DATE	APPROVED
A		10-12-83	RG WAS 200A	11-18-83	RWJ
B		2-23-84	R5 WAS 150A; R6 WAS 250A. ADDED U75 FOR VIDEO TRIMING	2-23-84	HAB RT
C		4-4-84	U23 REGISTER NETWORK REWIRING. TRIMMER INSPECTED. U20 U23 PARTS FOR VIDEO TIMING. ADDED 74LS157 TO CHANGE Q2 ON WHITE	4-4-84	HRB

UNOS. USED: 1, 2, 8, 9, 10, 13, 14, 15, 16, 20, 22, 23

QTY REQD	PART OR IDENTIFYING NO.	NOMENCLATURE OR DESCRIPTION	MFR. CODE	CIRCUIT REF.	ITEM NO.
----------	-------------------------	-----------------------------	-----------	--------------	----------

NON-LINEAR SYSTEMS, INC.  
 DEL MAR, CALIFORNIA

SCHEMATIC, VIDEO

KAYPRO 4/84

SIZE CODE IDENT NO. C 03626 81-185

SCALE WEIGHT SHEET 28

UNLESS OTHERWISE SPECIFIED  
 DIMENSIONS ARE IN INCHES  
 TOLERANCES ON DECIMALS ±.010  
 ANGLES ± 0° 30'  
 FRACTIONS ± 1/32

CONTR. NO. DRAWN RJ 9-1-83 CHECK APPR RWJ 7-5-83 RELEASE DATE 9-20-83 RSP

BOARD REV B (81-184)

APPLICATION	QTY.
NEXT ASSY.	FINAL ASSY.
NEXT FINAL ASSY.	FINAL ASSY.

**PROPRIETARY INFORMATION**  
 Not for distribution or transmission to any other person, organization or company without the permission of Kaypro Corporation.

6-40

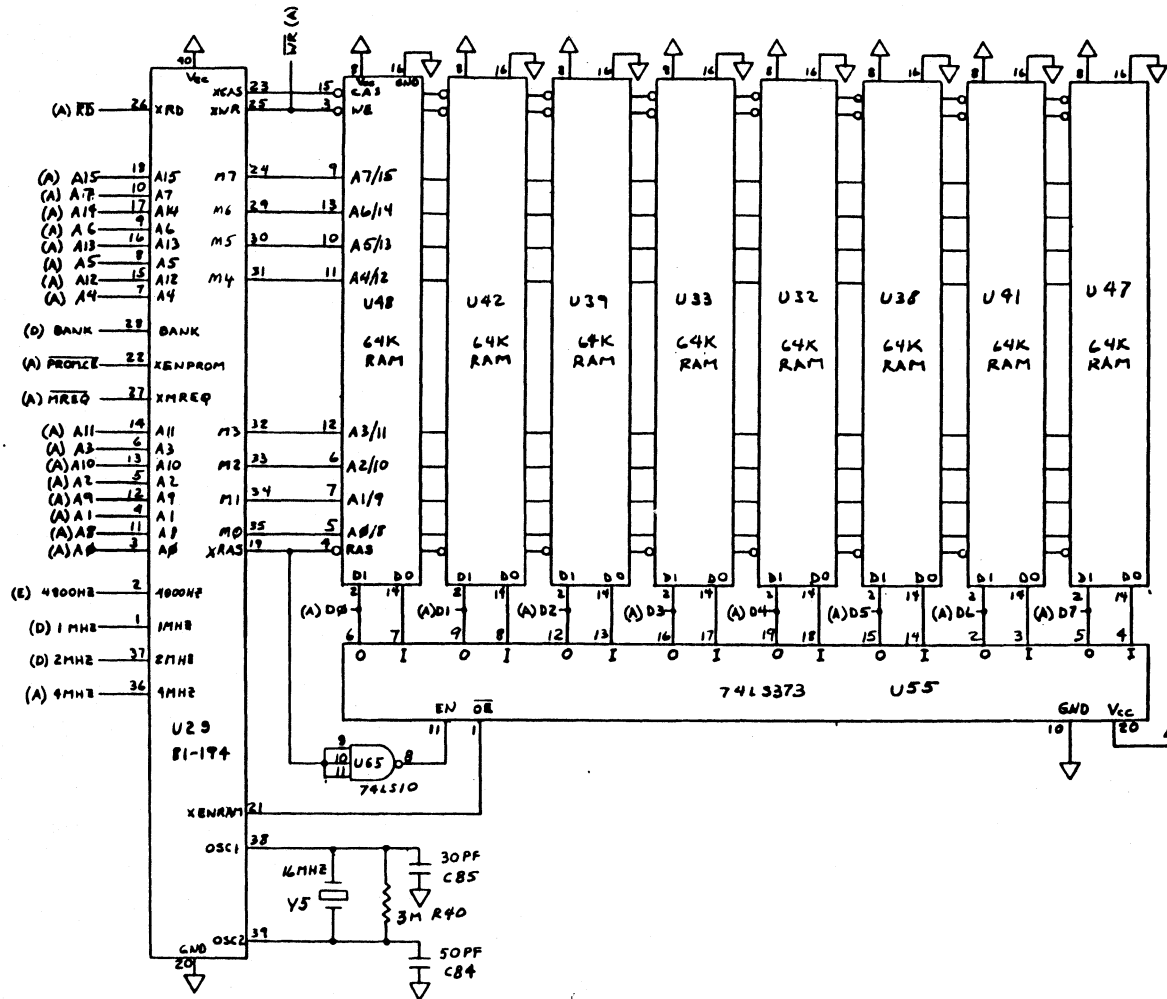

REVISIONS					
ZONE	LTR.	EFFECT.	DESCRIPTION	DATE	APPROVED

UNDS USED: 29, 48, 42,  
39, 33, 32, 38, 41, 47, 55,  
65

**PROPRIETARY INFORMATION**

Not for distribution or transmission to any other person, organization or company without the permission of Raypro Corporation.

QTY REQD	PART OR IDENTIFYING NO.	NOMENCLATURE OR DESCRIPTION	MFR. CODE	CIRCUIT REF.	ITEM NO.
PARTS LIST					
UNLESS OTHERWISE SPECIFIED DIMENSIONS ARE IN INCHES TOLERANCES ON DECIMALS ± .010 FRACTIONS ± 1/32					
CONTR. NO.		NON-LINEAR SYSTEMS, INC. DEL MAR, CALIFORNIA			
DRAWN R J		SCHEMATIC, RAM			
CHECK		KAYPRO 4/84			
APPR R J		SIZE CODE IDENT NO. C 03626			
RELEASE DATE 1-30-83 RSP		81-185			
MATERIAL		BOARD REV B (81-184)			
NEXT ASSY.	FINAL ASSY.	NEXT FINAL ASSY.	SCALE WEIGHT SHEET 2 C		
APPLICATION	QTY.				



REVISIONS					
ZONE	LTR.	EFFECT.	DESCRIPTION	DATE	APPROVED
	A	1948	"B" JUMPER INSTALLED IN FOIL	3-21-79	NAB AT

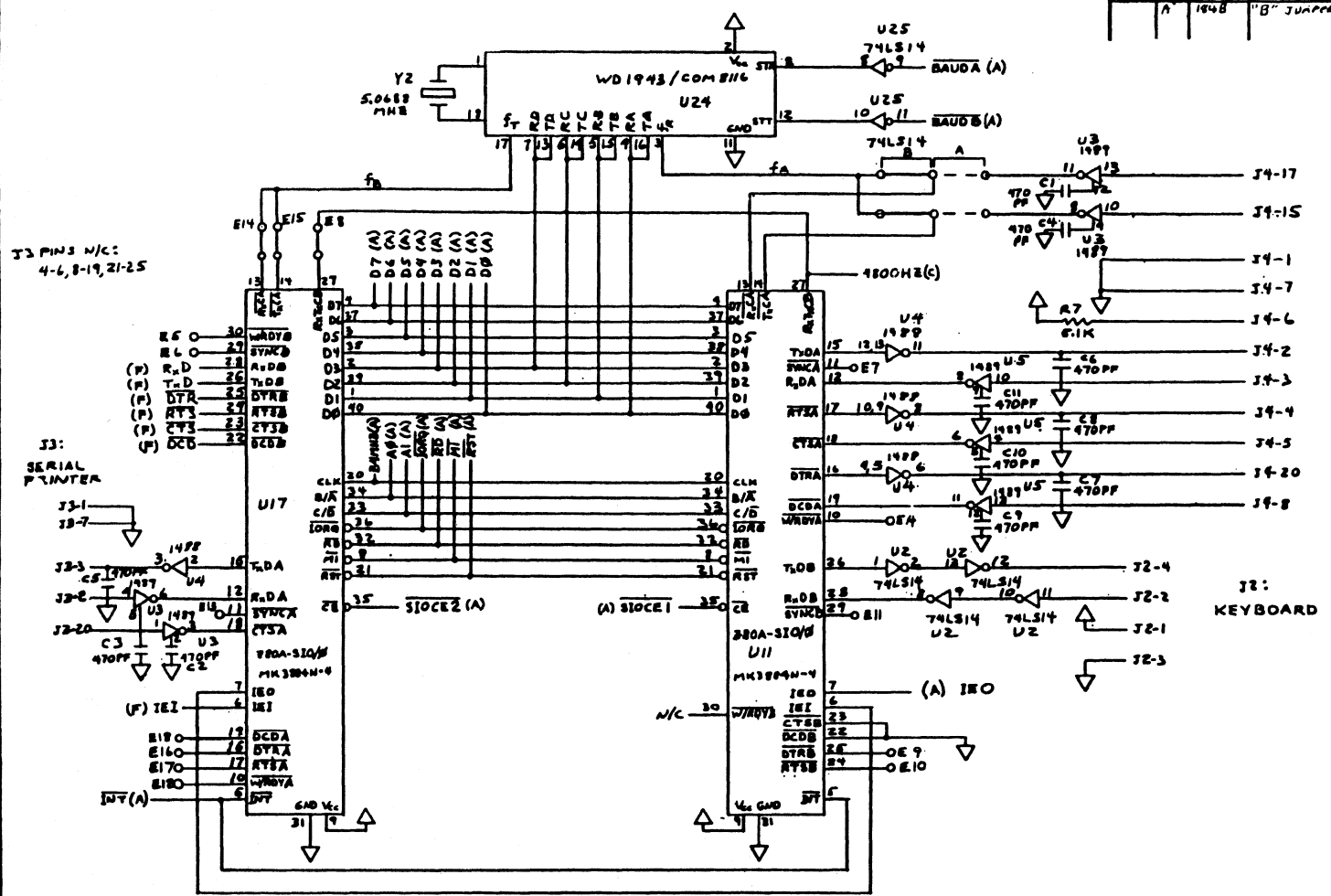

U NOS. USED: 23, 4, 5, 11  
17, 24, 25

J4:  
SERIAL  
DATA CHANNEL

J4 PINS N/C: 9-14, 16, 19, 21-25

J2:  
KEYBOARD

**PROPRIETARY INFORMATION**

Not for distribution or transmission to any other person, organization or company without the permission of Kaypro Corporation.

J3 PINS N/C:  
4-6, 8-19, 21-25

J3:  
SERIAL  
PRINTER

PWR TO U4: +12V TO PIN 14  
GND TO PIN 7  
-12V TO PIN 1

QTY REQD	PART OR IDENTIFYING NO.	NOMENCLATURE OR DESCRIPTION	MFR. CODE	CIRCUIT REF.	ITEM NO.
----------	-------------------------	-----------------------------	-----------	--------------	----------

PARTS LIST

UNLESS OTHERWISE SPECIFIED		CONTR. NO.	
DIMENSIONS ARE IN INCHES		DRAWN	R J
TOLERANCES ON		CHECK	
DECIMALS	* .00	APPR	RWJ
ANGLES	* 0° 30'	RELEASE DATE	9-20-83 KSD
FRACTIONS	* 1/32		

NON-LINEAR SYSTEMS, INC.  
DEL MAR, CALIFORNIA

SCHEMATIC, SERIAL PORTS

KAYPRO 4/84

SIZE CODE IDENT NO. 91-185

C 03626 SHEET 2 E

APPLICATION	QTY.
NEXT ASSY.	
FINAL ASSY.	
NEXT FINAL ASSY.	



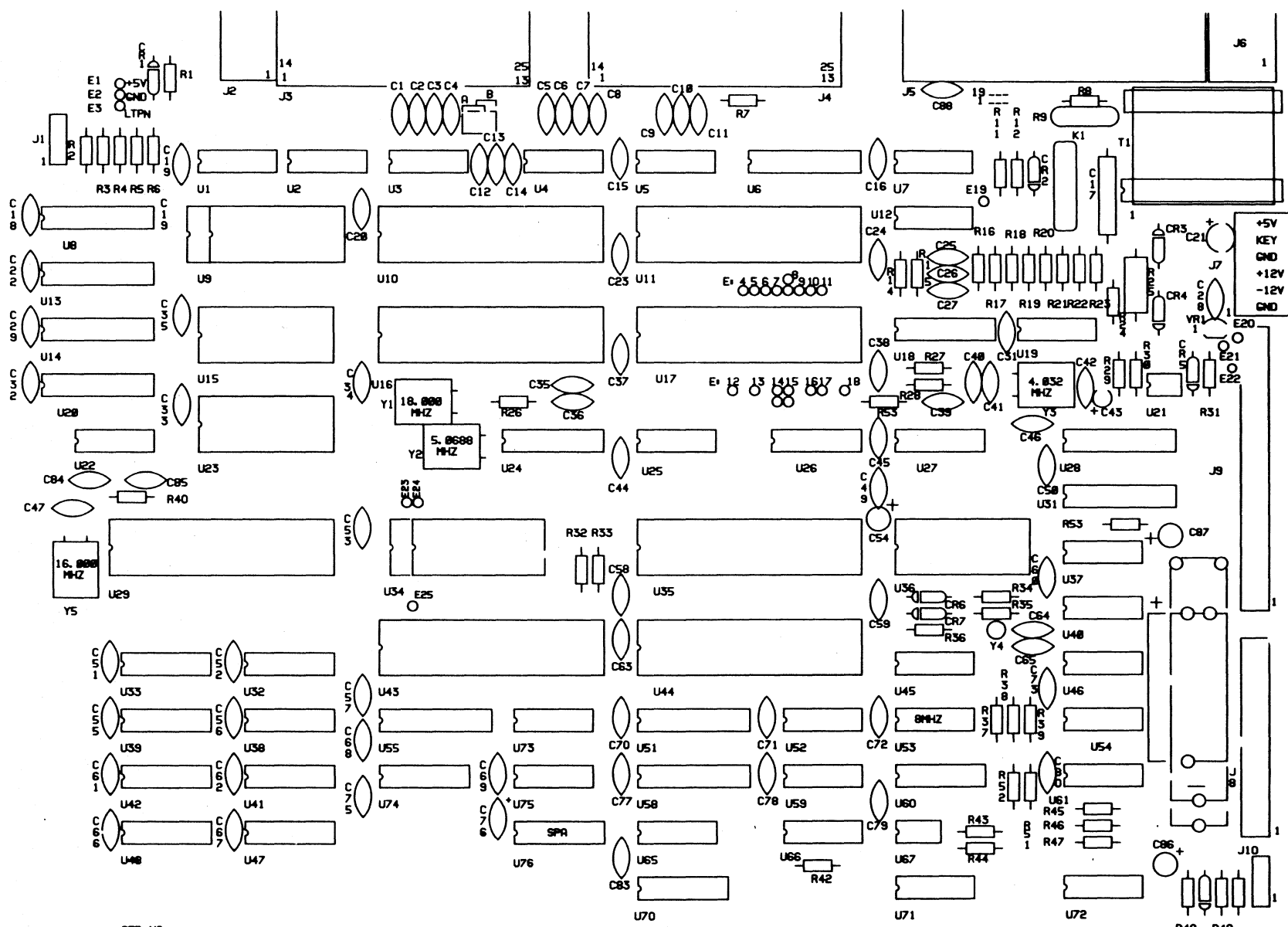

6-44

SER NO. \_\_\_\_\_

MADE IN U.S.A.

ASSY 81- \_\_\_\_\_

R48 R49  
CR8 R50





## IC LIST, 81-296-n

Reference Designation		Description
U1, U54	7406	Hex inverter, open collector
U2, U25, U71	74LS14	Hex Schmitt inverter
U3, U5	1489	Quad Schmitt line driver
U4	1488	Quad line driver
U6, U13, U14, U55, U58	74LS373	Octal "D" latch
U7	74LS38	Positive-NAND buffer
U8	74LS374	Octal "D" flip-flop
U9	81-235	Character PROM (2732)
U10	81-189	Custom gate array
U11, U17	Z80A SIO	
U12	LM324	Op-Amp
U15, U23	6116	Video RAM
U16	6545EA	Video controller
U18	TMS 99532	Modem
U19	TMS 99531	Dialer
U20, U31	74LS245	Octal bus transceiver
U21	4N35	Photo Isolator
U22	3.9K	Pullup resistor, 14-pin DIP
U24	WD1943/ 8116	Dual programmable baud rate generator
U26, U27	74LS138	3/8 MUX
U28, U51	74LS244	Octal buffer/line driver
U29	81-194	Custom gate array
U32, U33, U38, U39, U41, U42, U47, U48	2164	64K x 1 RAM
U34	81-326	Boot PROM (2764)
U35	Z80A PIO	
U36	MM581678	Clock
U37, U45, U59, U72	74LS02	Quad NOR gate
U40	74LS00	Quad NAND gate
U43	Z80A CPU	
U44	1793	Floppy disk controller
U46	74LS04	Hex inverter
U52	74LS32	Quad OR gate
U70, U74, U75		Spares
U60	74LS195	4-bit shift register
U61	74LS08	Quad AND gate
U65	74LS10	Tri NAND gate
U66, U75	74LS74	Dual "D" flip-flop
U67	FDC9216	Data separator
U73	74HC00	Quad NAND gate

**SCOPE SIGNALS, 81-296-n**

\*\*\*\*\*

Scope signals for this mainboard will be available soon; the section will be sent to the dealers for insertion into the new Technical Reference Manual as soon as it is available.

\*\*\*\*\*

REVISIONS					
ZONE	LTR.	EFFECT.	DESCRIPTION	DATE	APPROVED
E210	SFR	J9-48			

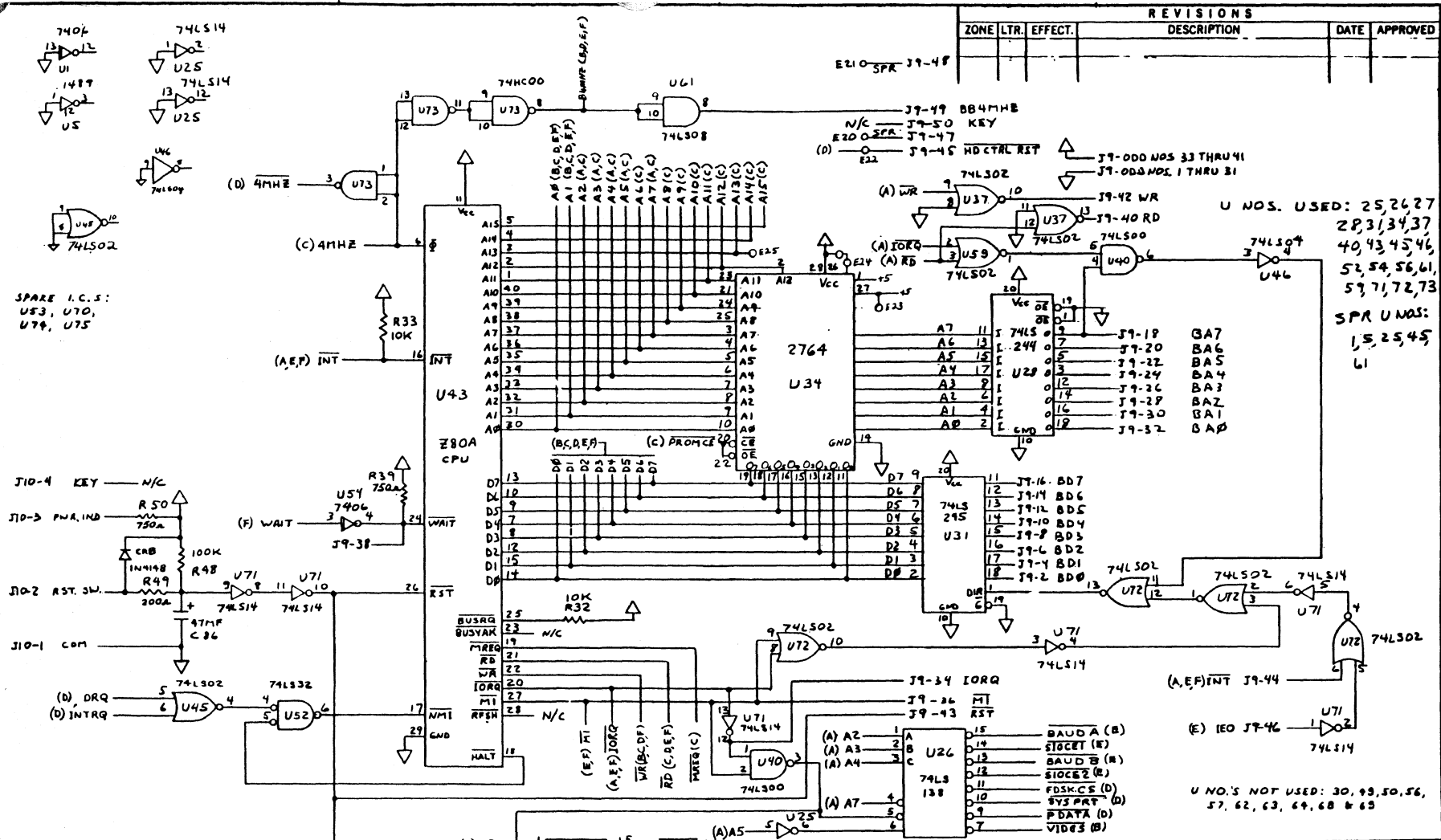

SPARE I.C.'S:  
U53, U70,  
U74, U75

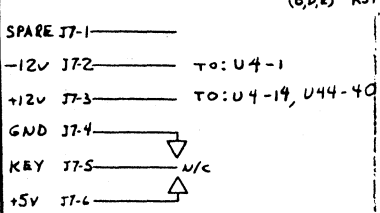
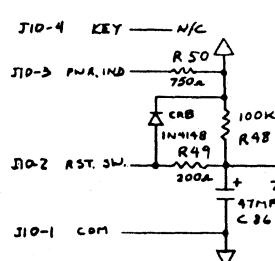

**PROPRIETARY INFORMATION**

This document contains information that is the property of Non-Linear Systems, Inc. and is to be used only for the purposes specified herein. No part of this document may be reproduced or transmitted in any form or by any means, electronic, mechanical, photocopying, recording, or by any information storage and retrieval system, without the prior written permission of Non-Linear Systems, Inc.

Keytron Corporation

U NOS. USED: 25, 26, 27, 28, 31, 34, 37, 40, 43, 45, 46, 52, 54, 56, 61, 59, 71, 72, 73

SPR U NOS: 1, 5, 25, 45, 61

U NO.	DESCRIPTION	U NO.	DESCRIPTION
25	74LS02	31	74LS02
26	74LS02	34	74LS02
27	74LS02	37	74LS02
28	74LS02	40	74LS02
31	74LS02	43	74LS02
34	74LS02	45	74LS02
37	74LS02	46	74LS02
40	74LS02	52	74LS02
43	74LS02	54	74LS02
45	74LS02	56	74LS02
46	74LS02	61	74LS02
52	74LS02		
54	74LS02		
56	74LS02		
61	74LS02		

U NOS. NOT USED: 30, 49, 50, 56, 57, 62, 63, 64, 68 & 65

QTY REQD	PART OR IDENTIFYING NO.	NOMENCLATURE OR DESCRIPTION	MFR. CODE	CIRCUIT REF.	ITEM NO.
----------	-------------------------	-----------------------------	-----------	--------------	----------

UNLESS OTHERWISE SPECIFIED  
DIMENSIONS ARE IN INCHES  
TOLERANCES ON  
DECIMALS ±.010  
FRACTIONS ± 1/32

CONTR. NO.	
DRAWN	R J 9-2-83
CHECK	
APPR	R J 9-15-83
RELEASE DATE	3-6-84/KSI

**NLS NON-LINEAR SYSTEMS, INC.**  
DEL MAR, CALIFORNIA

**SCHEMATIC, PROCESSOR**

ROBIE

SIZE	CODE IDENT NO.	SCALE	WEIGHT	SHEET	NO.
C	03626			81-297	2A

6-47

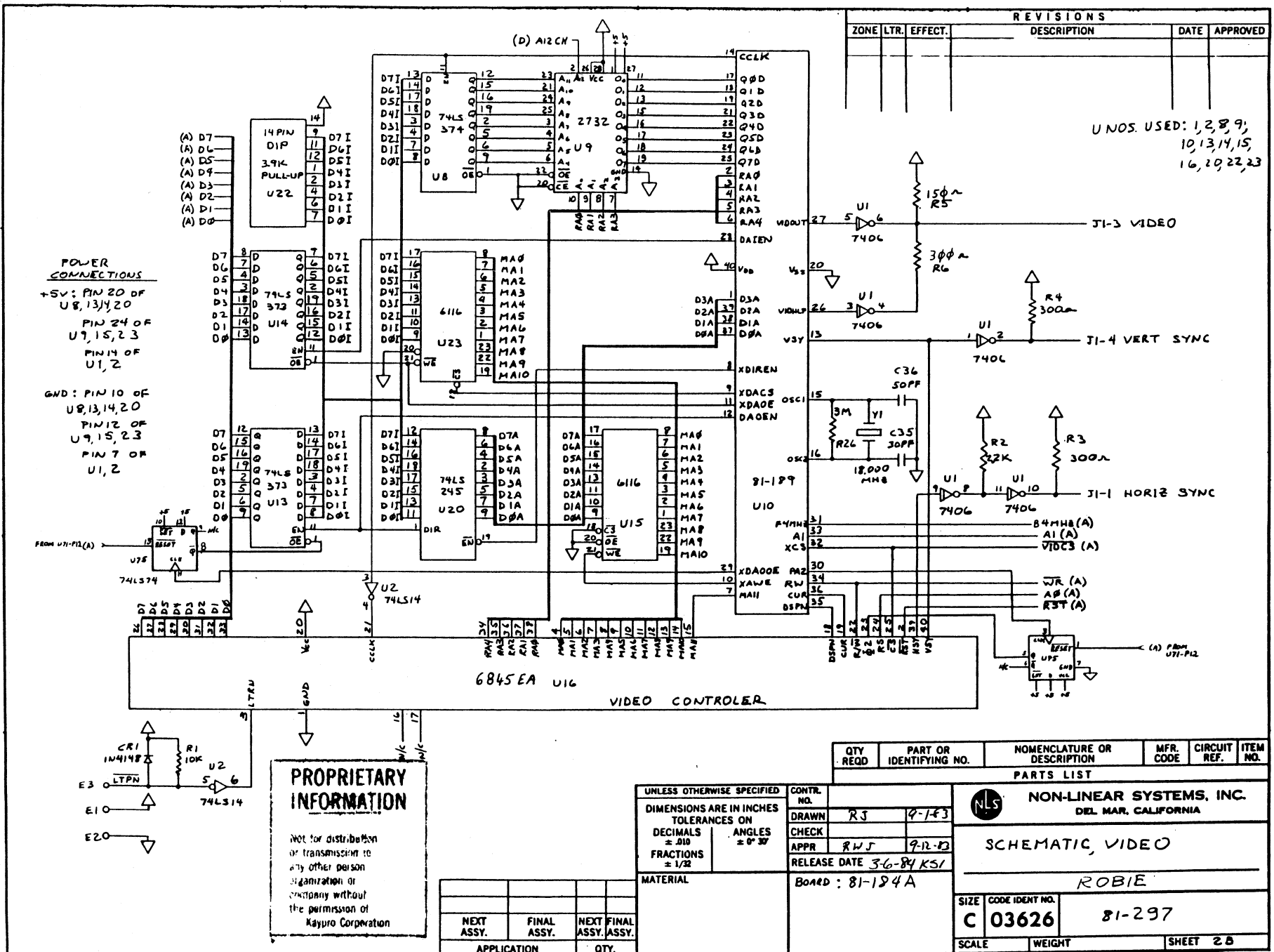

**POWER CONNECTIONS**  
 +5V: PIN 20 OF U8, 13, 14, 20  
 PIN 24 OF U7, 15, 23  
 PIN 14 OF U1, 2  
 GND: PIN 10 OF U8, 13, 14, 20  
 PIN 12 OF U7, 15, 23  
 PIN 7 OF U1, 2

**PROPRIETARY INFORMATION**  
 Not for distribution or transmission to any other person, organization or company without the permission of Kaypro Corporation

REVISIONS					
ZONE	LTR.	EFFECT.	DESCRIPTION	DATE	APPROVED

UNOS. USED: 1, 2, 8, 9,  
 10, 13, 14, 15,  
 16, 19, 22, 23

QTY	PART OR IDENTIFYING NO.	NOMENCLATURE OR DESCRIPTION	MFR. CODE	CIRCUIT REF.	ITEM NO.
PARTS LIST					
<b>NON-LINEAR SYSTEMS, INC.</b> DEL MAR, CALIFORNIA					
SCHEMATIC, VIDEO					
ROBIE					
SIZE	CODE IDENT NO.	81-297			
C	03626				
SCALE	WEIGHT	SHEET 28			

UNLESS OTHERWISE SPECIFIED		CONTR. NO.
DIMENSIONS ARE IN INCHES		DRAWN RJ 9-1-83
TOLERANCES ON		CHECK
DECIMALS ± .010	ANGLES ± 0° 30'	APPR RJS 9-12-83
FRACTIONS ± 1/32		RELEASE DATE 3-6-84 KSI
MATERIAL		BOARD: 81-124A
NEXT ASSY.	FINAL ASSY.	NEXT FINAL ASSY.
APPLICATION		QTY.

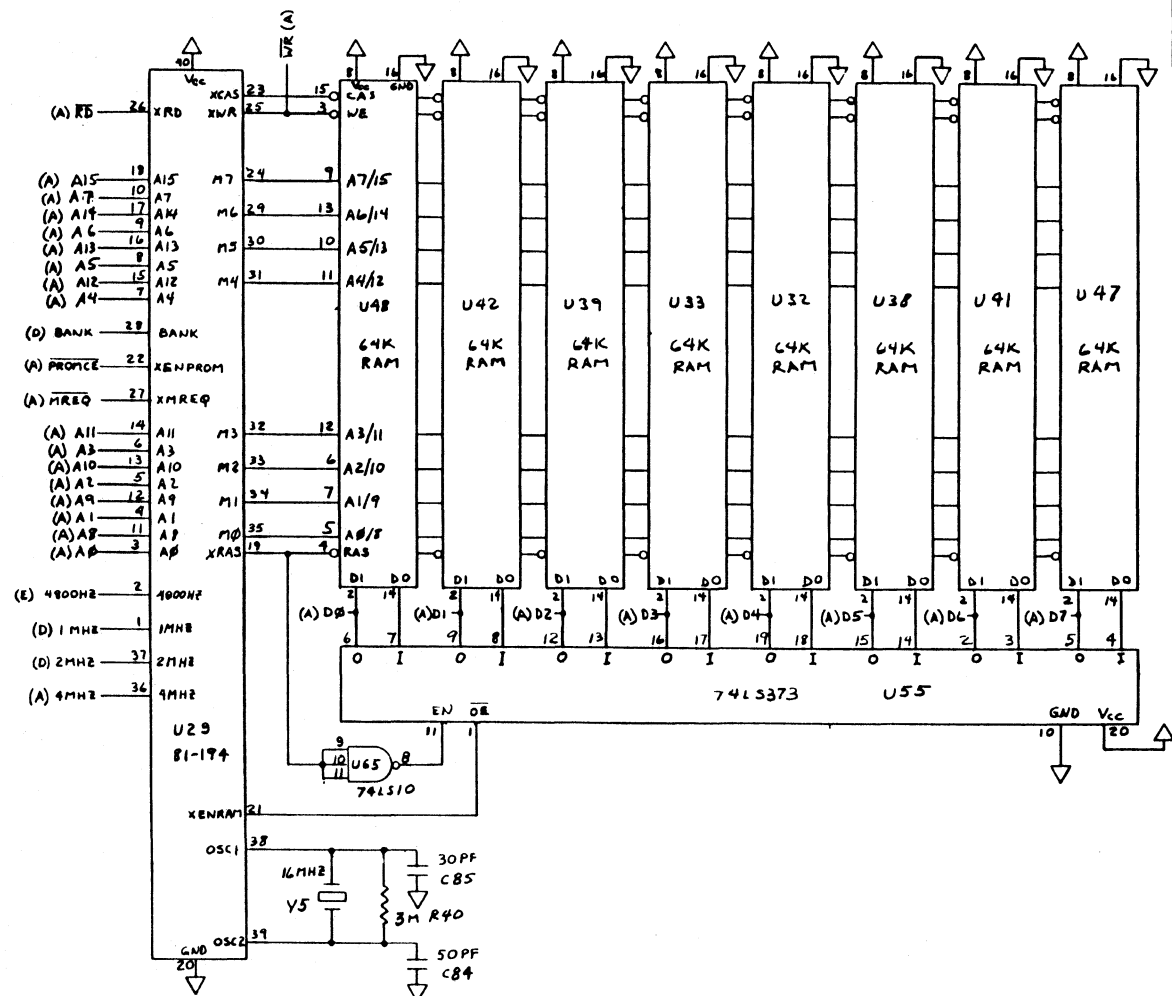

REVISIONS					
ZONE	LTR.	EFFECT.	DESCRIPTION	DATE	APPROVED

UNOS USED: 29, 48, 42,  
39, 33, 32, 38, 41, 47, 55,  
65

**PROPRIETARY INFORMATION**

Not for distribution or transmission to any other person or organization or company without the permission of Raypro Corporation

QTY REQD	PART OR IDENTIFYING NO.	NOMENCLATURE OR DESCRIPTION	MFR. CODE	CIRCUIT REF.	ITEM NO.
----------	-------------------------	-----------------------------	-----------	--------------	----------

PARTS LIST  
**NON-LINEAR SYSTEMS, INC.**  
 DEL MAR, CALIFORNIA

UNLESS OTHERWISE SPECIFIED  
 DIMENSIONS ARE IN INCHES  
 TOLERANCES ON  
 DECIMALS ± 0.10  
 FRACTIONS ± 1/32  
 ANGLES ± 0° 30'

CONTR. NO.  
 DRAWN R J 7-83  
 CHECK  
 APPR R J 7-16-83  
 RELEASE DATE 3-6-84 KSI

MATERIAL  
 Bond 81-184 A

**SCHMATIC, RAM**  
 ROBIE

NEXT ASSY.	FINAL ASSY.	NEXT ASSY.	FINAL ASSY.
APPLICATION		QTY.	

SIZE	CODE IDENT NO.	
C	03626	81-297
SCALE	WEIGHT	SHEET 2 C

6-50

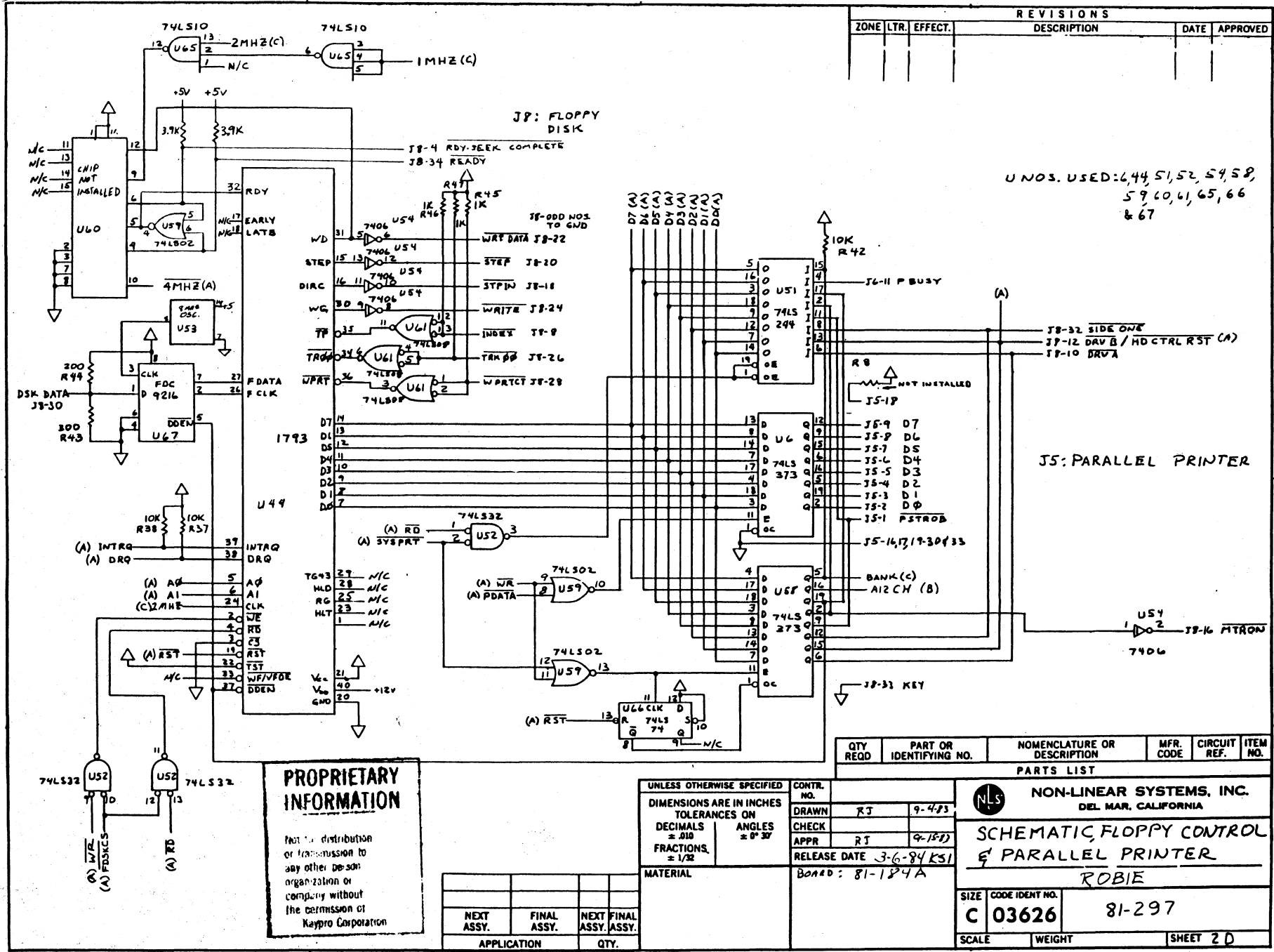

REVISIONS					
ZONE	LTR.	EFFECT.	DESCRIPTION	DATE	APPROVED

UNOS. USED: 6, 44, 51, 52, 54, 58,  
59, 60, 61, 65, 66  
& 67

**PROPRIETARY INFORMATION**

Not for distribution or transmission to any other person, organization or company without the permission of Kaypro Corporation

NEXT ASSY.	FINAL ASSY.	NEXT FINAL ASSY.	FINAL ASSY.
APPLICATION		QTY.	

UNLESS OTHERWISE SPECIFIED  
DIMENSIONS ARE IN INCHES  
TOLERANCES ON  
DECIMALS = .010  
FRACTIONS = 1/32  
ANGLES = 0° 30'

CONTR. NO.	
DRAWN	RJ 9-4-83
CHECK	
APPR	RJ 9-18-83
RELEASE DATE	3-6-84 KSI
BOARD	81-184A

<b>NON-LINEAR SYSTEMS, INC.</b> DEL MAR, CALIFORNIA	
<b>SCHEMATIC FLOPPY CONTROL &amp; PARALLEL PRINTER</b> ROBIE	
SIZE	CODE IDENT NO.
C	03626
SCALE	WEIGHT
	SHEET 2 D

QTY REQD	PART OR IDENTIFYING NO.	NOMENCLATURE OR DESCRIPTION	MFR. CODE	CIRCUIT REF.	ITEM NO.

REVISIONS					
ZONE	LTR.	EFFECT.	DESCRIPTION	DATE	APPROVED

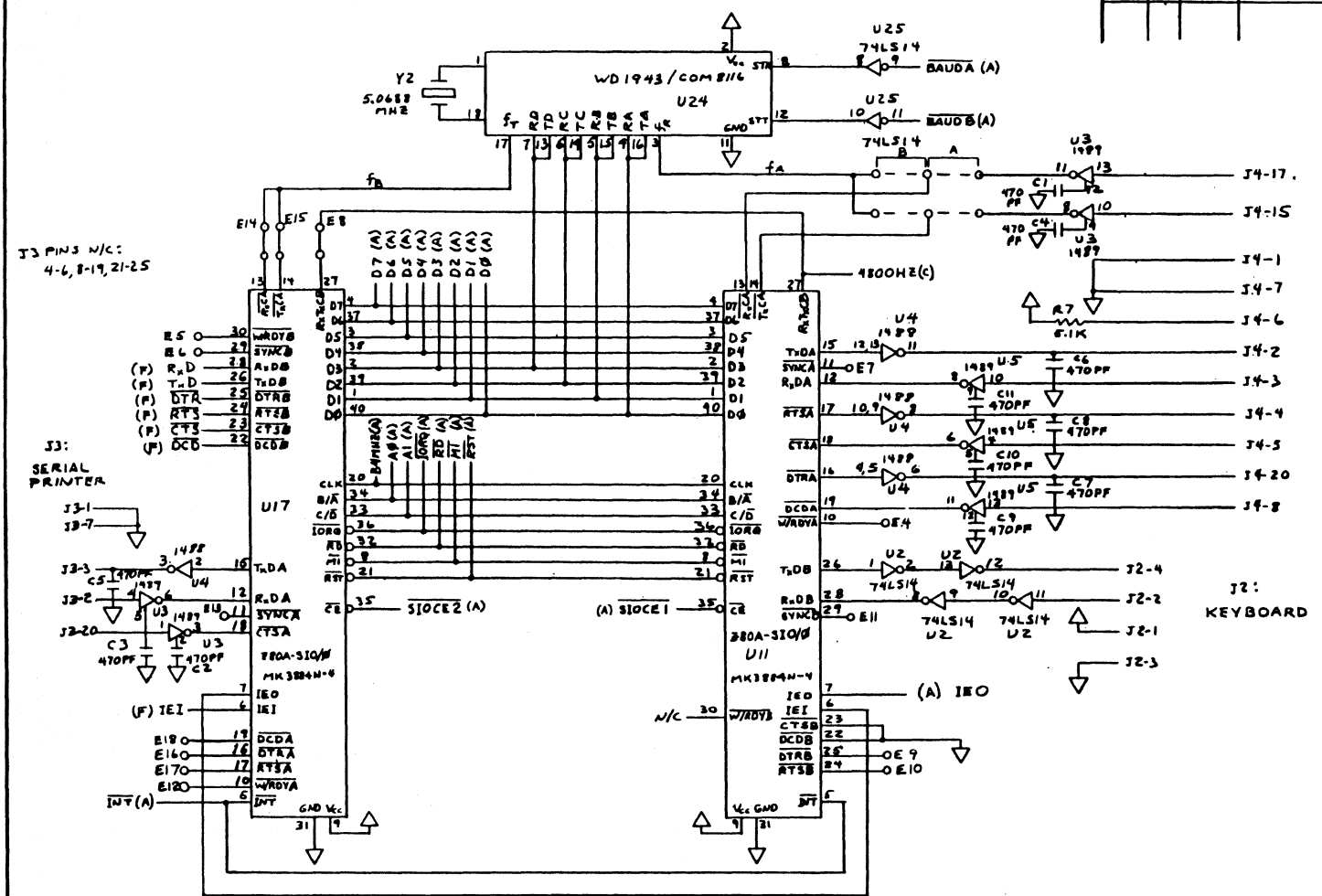

U NOS. USED: 2, 3, 4, 5, 11  
17, 24, 25

J4:  
SERIAL  
DATA CHANNEL

J4 PINS W/C: 9-14, 16, 19, 21, 25

J3 PINS W/C:  
4-6, 8-19, 21-25

J3:  
SERIAL  
PRINTER

J2:  
KEYBOARD

**PROPRIETARY INFORMATION**  
Not for distribution or transmission to any other person organization or company without the permission of Kaypro Corporation

PWR TO U4: +12V TO PIN 14  
GND TO PIN 7  
-12V TO PIN 1

QTY REQD	PART OR IDENTIFYING NO.	NOMENCLATURE OR DESCRIPTION	MFR. CODE	CIRCUIT REF.	ITEM NO.
----------	-------------------------	-----------------------------	-----------	--------------	----------

PARTS LIST

UNLESS OTHERWISE SPECIFIED		CONTR. NO.	
DIMENSIONS ARE IN INCHES		DRAWN	R J 9-3-83
TOLERANCES ON		CHECK	
DECIMALS ±.010	ANGLES ±0°30'	APPR	E F 9-11-83
FRACTIONS ±1/32		RELEASE DATE	3-6-84 KS1

**NON-LINEAR SYSTEMS, INC.**  
DEL MAR, CALIFORNIA  
**SCHEMATIC, SERIAL PORTS**

APPLICATION	QTY.
NEXT ASSY.	
FINAL ASSY.	
NEXT FINAL ASSY.	

MATERIAL BOARD: 81-184 A

SIZE	CODE IDENT NO.	
C	03626	81-297
SCALE	WEIGHT	SHEET 2 E

6-51

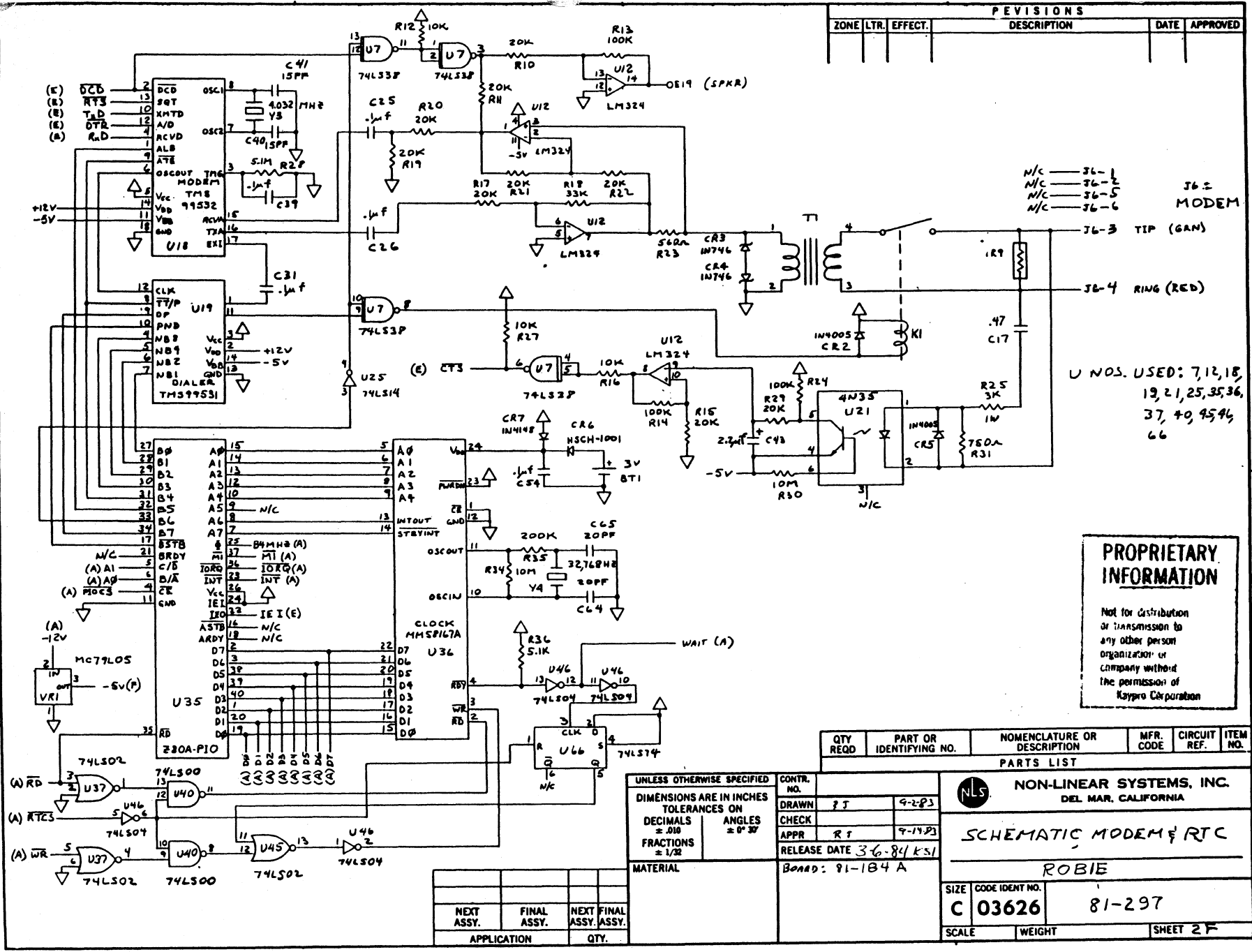

REVISIONS					
ZONE	LTR.	EFFECT.	DESCRIPTION	DATE	APPROVED

N/C — 36-1  
 N/C — 36-2  
 N/C — 36-5  
 N/C — 36-6

J6 = MODEM

U NOS. USED: 7, 12, 18,  
 19, 21, 25, 35, 36,  
 37, 40, 45, 46,  
 66

**PROPRIETARY INFORMATION**

Not for distribution or transmission to any other person, organization or company without the permission of Kaypro Corporation

QTY REQD	PART OR IDENTIFYING NO.	NOMENCLATURE OR DESCRIPTION	MFR. CODE	CIRCUIT REF.	ITEM NO.
PARTS LIST					

UNLESS OTHERWISE SPECIFIED		CONTR. NO.	
DIMENSIONS ARE IN INCHES		DRAWN	J J
TOLERANCES ON		CHECK	9-2-83
DECIMALS	± .010	APPR	R T
ANGLES	± 0° 30'	RELEASE DATE	3-6-84 ksl
FRACTIONS	± 1/32	BOARD:	81-184 A

**NON-LINEAR SYSTEMS, INC.**  
 DEL MAR, CALIFORNIA

**SCHEMATIC MODEM & RTC**

**ROBIE**

NEXT ASSY.	FINAL ASSY.	NEXT FINAL ASSY.
APPLICATION	QTY.	

SIZE	CODE IDENT NO.	81-297
C	03626	
SCALE	WEIGHT	SHEET 2 F



## 6.7 MAINBOARD REMOVAL

1. Turn off the machine and disconnect the AC power (5.1).
2. Remove the chassis hood (5.1).
3. Remove the two screws from the front of the mainboard that attach the mainboard and the two plastic standoffs.
4. Remove the screws from the rear, top of the chassis that secure the mainboard. The KAYPRO 2/83 and 4/83 each have four Phillips-head screws and two hex-head screws. The KAYPRO 10, 2/84 and 4/84 each have three Phillips-head screws and four hex-head screws.
5. Remove the power, reset, and video plugs. On the KAYPRO 2/83 and 4/83 these are J1, J5, and J7. On the KAYPRO 10, 2/84 and 4/84 these are J1, J7, and J10.
6. Remove the ribbon cable(s). On the KAYPRO 2/83 and 4/83 this is J6. On the KAYPRO 10 they are J8 and J9. On the KAYPRO 2/84 and 4/84 this is J8.
7. Remove the mainboard.

## MAINBOARD INSTALLATION

1. Set the mainboard on the plastic standoffs, insert the screws, but do not tighten them yet.
2. Align the ports and the keyboard jack with the openings on the rear, top of the chassis.
3. Insert the screws through rear of chassis into mounting holes. Do not tighten yet.
4. The KAYPRO 2/83 and 4/83 each have four Phillips-head and two hex-head screws. The KAYPRO 10, 2/84 and 4/84 each have three Phillips-head and four hex-head screws.
5. Tighten the screws on the rear of the chassis and the screws that go into the plastic standoffs.
6. Replace the power, reset, and video plugs.
7. Replace the ribbon cable(s).

## 7.0 CRT ASSEMBLIES

### 7.1 HARDWARE DESCRIPTIONS AND ADJUSTMENTS

Figure 7.1  
Dotronix video board

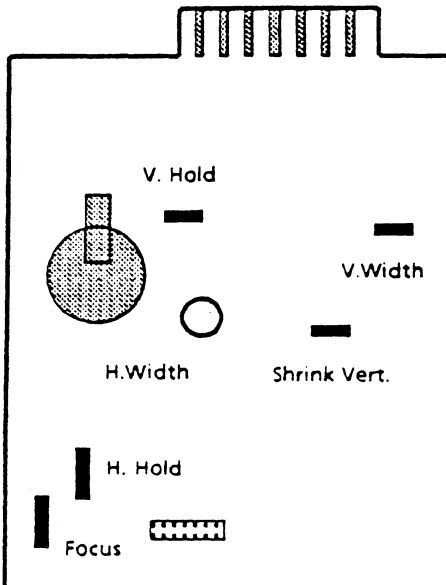
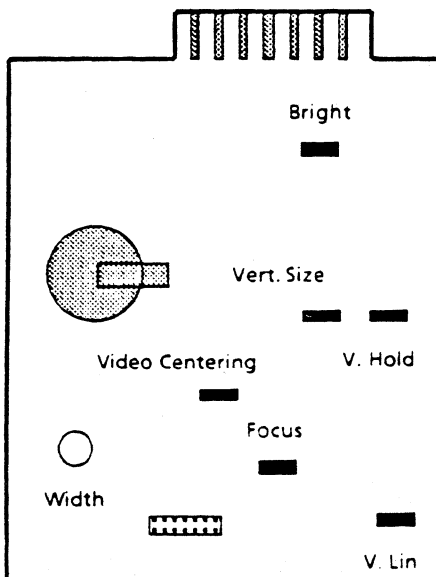

Figure 7.2  
Elston video board



#### VIDEO ADJUSTMENTS

At the current time Kaypro is using CRT assemblies produced by Dotronix, Elston, and Toshiba. The adjustment pots are positioned in different locations on the boards and can be located by using figures 7-1, 7-2, and 7-3. These pots are factory aligned and normally need no adjustment. The purpose of these adjustments is to obtain the correct size, centering, and brightness of the display.

Use only non-metallic tools when making these adjustments.

Before any adjustments are made on the video board, the ALIGN diagnostic should be invoked. This will fill the screen with H's and aid in adjustment.

#### HORIZONTAL CENTERING

Check to see that the pattern is centered on the screen. Adjust the horizontal hold pot until the display is correctly centered. On the Elston video board, adjust the video centering pot.

#### VERTICAL SIZE AND LINEARITY

The following two procedures are to be performed alternately until correct display is obtained.

Adjust the vertical size pot to obtain pattern height of approximately 4-7/8 inches.

Adjust vertical linearity pot until all characters are the same vertical size, top to bottom.

#### HORIZONTAL WIDTH

Adjust the horizontal width pot to obtain a display width of approximately 7 inches.

## HORIZONTAL HOLD (KAYPRO 2/83 and 4/83 with Dotronix only)

Figure 7.3  
Toshiba video board

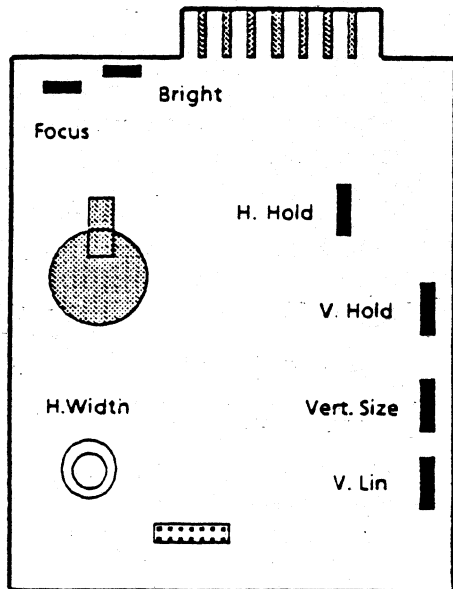

These procedures should be performed to adjust horizontal hold.

Attach one end of a test jumper to TP2 (test point 2). Attach the other end of the jumper to the heat sink at Q3.

Adjust R43 (horizontal hold pot) until the display either stops scrolling or almost stops. (sometimes they don't stop scrolling completely)

Disconnect the test jumper.

Adjust the horizontal deflection rings as needed.

### FOCUS

Adjust the focus pot until the edges and center of the display image are in focus.

### BRIGHTNESS

To prolong the life of the CRT, the maximum brightness obtainable should not be excessive. If the brightness is excessive, adjust the brightness pot. If the raster lines are visible, the brightness pot should be adjusted until they disappear.

Figure 7.4  
Yoke alignment

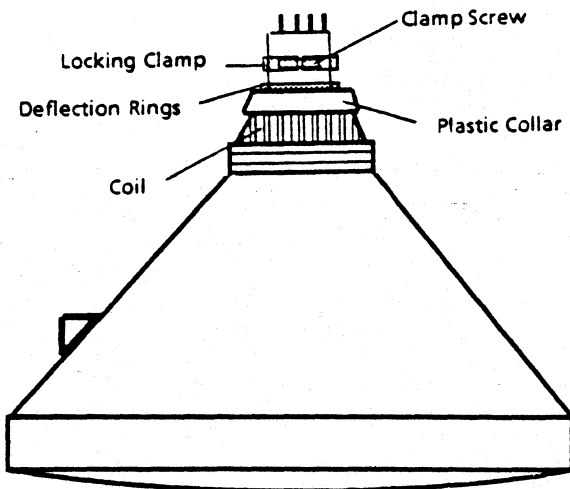

### ALIGNING CRT YOKE

\*\*\* CAUTION \*\*\*

HIGH VOLTAGE IS PRESENT AT THIS POINT

Loosen the screw on the locking clamp (figure 7-4).

Grasp the white collar on the rear of the coil.

Turn the collar in the direction required to square the display.

Turn the collar slightly past the alignment point, as it will turn back slightly when released.

Tighten the locking screw.

## VIDEO ADJUSTMENTS FOR MICREX CRT

The same procedures should be used to adjust the Micrex CRT assembly as those used for the other brands of CRTs.

Figure 7.5  
Micrex video board

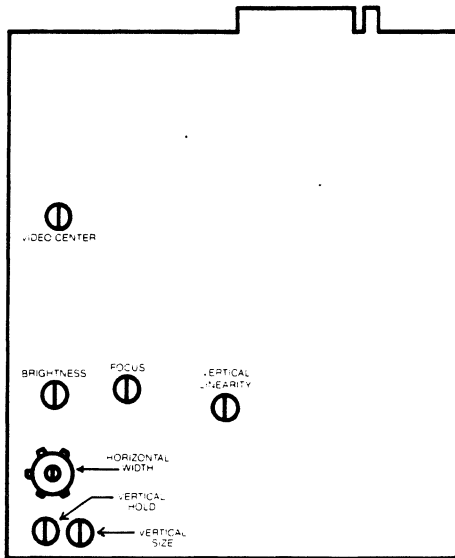

## 7.2 PERFECT VIDEO ALIGNMENT EXAMPLE

Below is an example of perfect video alignment with a capital E positioned along the borders. You can copy this diagram onto a piece of clear, stiff plastic to use as a template over the screen.

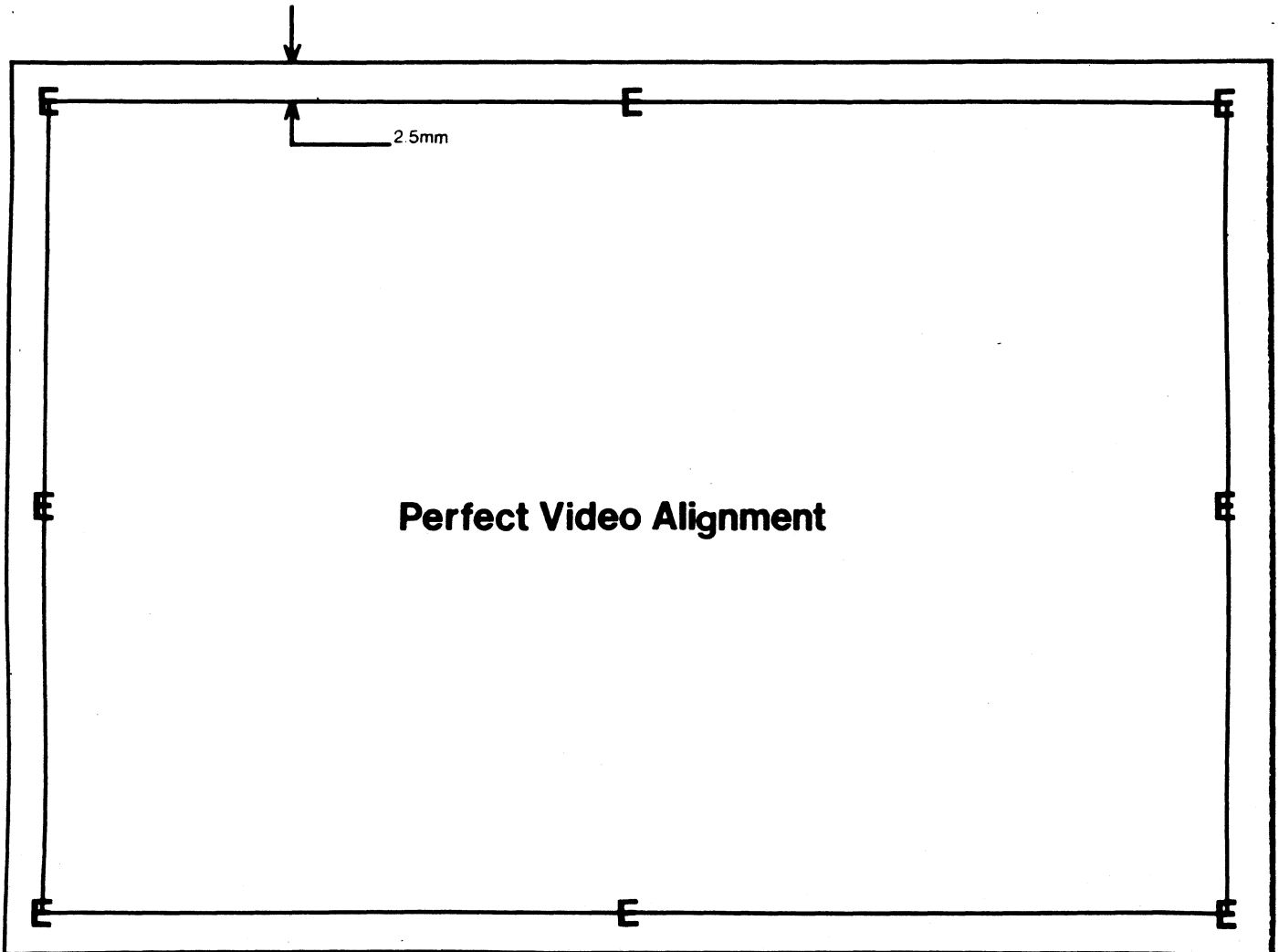

### 7.3 VIDEO SIGNALS, ON KAYPRO MAINBOARD

Below is a list of the video signals on connector J1 of the mainboard and the voltages on the video board. Repeated removal and installation of the video board connector will loosen the connection and produce poor contact. Malfunctions due to a loose connector can be very difficult to trace.

Video comes from the main board as separate signals, not as a composite like a TV signal.

A simple check for 12V on the video board is to turn the BRIGHTNESS pot up, then turn the rear panel brightness control down. If 12V is present on the board, you should be able to see the raster lines on the screen.

#### Video signals on main board at J1

- Pin 1 - Horizontal Sync.
- Pin 2 - Key
- Pin 3 - Video
- Pin 4 - Vertical Sync.

#### Voltages on Video Board

- Pin 1 → 0v
- Pin 6 → 0v
- Pin 7 → 12v
- Pin 8 → 0v
- Pin 9 → 4v approx. (this voltage controls brightness)
- Pin 10 → 0v

## 7.4 LISTING OF ALIGN.MAC

If you have the assembly language utilities M-80 and L-80, this diagnostic can be typed into the KAYPRO, then turned into a CCM file by running M-80, then L-80.

```
*****
; kaypro alignment test routine
;
; first a program to move this routine above 8000h
; so we can turn on the other page of memory
; and address the video page directly
;
start:
    ld    hl,first+1
    ld    de,dest
    ld    bc,last-first1
    ldir
    jp    dest
;
dest    equ    08000h
first:  defb    0
;
        .phase dest
;
;beginning of the program
; first turn off the drives and turn on the vid page
;
first1:
    in    a,(01ch)
    set   7,a    ;turn on the vid page
    set   6,a    ;turn off drives
    res   0,a    ;turn off drive a light
    res   1,a    ;turn off drive b light
    out   (01ch),a
;
    ld    hl,3000h    ;beginning of the vid page
    ld    (hl),'H'
    ld    de,3000h+1
    ld    bc,3*1024    ;how many
    ldir
;
; now vid page filled with H
;
    ld    hl,msg1
    ld    de,03580h    ;line 12
    ld    bc,80
    ldir
;
    ld    hl,msg2
    ld    de,03600h    ;line 13
    ld    bc,80
    ldir
```

#### 7.4 ALIGN.MAC LISTING (CONTINUED)

```
;
loop:
    call    delay
    call    aon
    call    delay
    call    aoff
    call    delay
    call    bon
    call    delay
    call    boff
    jp     loop

;
;
aon:
    in     a,(01ch)
    set    0,a
    out    (01ch),a
    ret

aoff:
    in     a,(01ch)
    res    0,a
    out    (01ch),a
    ret

bon:
    in     a,(01ch)
    set    1,a
    out    (01ch),a
    ret

boff:
    in     a,(01ch)
    res    1,a
    out    (01ch),a
    ret

;
delay:
    ld     bc,2
delay0:
    ld     hl,0
delay1:
    dec    hl
    ld     a,h
    or     l
    jp    nz,delay1
    dec    bc
    ld     a,b
    or     c
    jp    nz,delay0
    ret

;
```



#### 7.4 ALIGN.MAC LISTING (CONTINUED)

```
;
;
msg1:  defb      '12345678901234567890123456789012
         defb      'HHHHHHHHHHHHHHHHHHHHHHHHHHHHHHHHHH'
         defb      '      KAY', 'P' OR 080h, 'R' OR 080h, 'O II  '
         defb      'HHHHHHHHHHHHHHHHHHHHHHHHHHHHHHHHHH'
msg2:  defb      'HHHHHHHHHHHHHHHHHHHHHHHHHHHHHHHHHH'
         defb      ' crt ad', 'j' or 080h, 'u' or 080h, 'stment '
         defb      'HHHHHHHHHHHHHHHHHHHHHHHHHHHHHHHHHH'
;
last:  defb      0,0,0
         end      start
;
```

## 7.5 CRT ASSEMBLY REMOVAL, (EXCEPT ROBIE)

1. Turn off the machine and disconnect the AC power (5.1).
2. Remove the chassis hood (5.1).
3. Remove the mainboard (6.7).
4. Remove the four screws that connect the video PCB and the bottom of the chassis. This should be done from the outside, bottom of the chassis, not from inside the machine.
5. Remove the video connector from the back of the video PCB.
6. Remove the four screws that connect the CRT to the front of the machine chassis.
7. Remove the CRT assembly from the chassis.
8. Remove the four plastic standoffs from the CRT PCB. These can be used on the new CRT PCB.

### CRT ASSEMBLY INSTALLATION

\*\*\* Note: Before starting with CRT installation, check to see if the small plastic standoffs are attached to the bottom of the CRT PCB. If they are not attached, use the ones from the old board.

1. Lower the CRT assembly into the chassis.
2. Position the CRT so that the top mounting holes are aligned with the two metal standoffs on the chassis.
3. Insert screws through the top two mounting holes on the CRT and into the standoffs, but do not tighten.
4. Insert screws through the bottom two mounting holes on the CRT and into the standoffs. Tighten these two screws and the top two screws.
5. Hold the CRT PCB in place and tilt the machine up so that it is sitting on the cord wraps.
6. Align the plastic standoffs on the PCB with the holes in the bottom of the chassis.
7. Insert the four screws and tighten securely.
8. Replace the video connector on the back of the video PCB.

## 8.0 POWER SUPPLIES

### 8.1 INTRODUCTION

Kaypro is using three different brands of power supplies at the present time. These are Astec, Boschert, and Cal D.C. These three power supplies are interchangeable with any of the Kaypro computers, if the power supply being changed is a new one from the factory.

#### \*\*\* EXCEPTION \*\*\*

If a power supply is removed from a 2/83 or a 4/83, and it's going to be used in another computer, it MUST be used in a 2/83 or 4/83. The power supplies used in 2/83 and 4/83 computers are not interchangeable with other Kaypro computers.

\*\*\*\*\*

There are no authorized dealer repairs that can be made on any of the power supplies. The ONLY authorized dealer service to power supplies is 220V configuration. Each brand of power supply can be configured for 220V operation.

## 8.2 DESCRIPTION AND 220V CONFIGURATION INSTRUCTIONS

Two fuses are associated with each of the power supplies. One fuse (2 amp) is mounted on the rear of the chassis and accessible from outside the computer. The other fuse (2.5 amp) is mounted directly on the power supply board.

Disconnect AC power from the computer whenever replacing fuses. Be especially careful when replacing the fuse on the power supply board. Use of a fuse replacement tool is recommended due to the difficulty of reaching this component.

### 220V CONFIGURATION

#### Astec Power Supply

Identified by a beige board with a white label on the right of the component side. The label will have the name ASTEC, followed by a model number, and the output voltages.

Locate the white shorting block labelled TB2. If the board is configured for 110V, a pin will be visible on the right of the shorting block.

Remove the shorting block and shift it to the right so that it covers the pin. A different pin should now be exposed on the left of the shorting block. The power supply is now configured for 220V use.

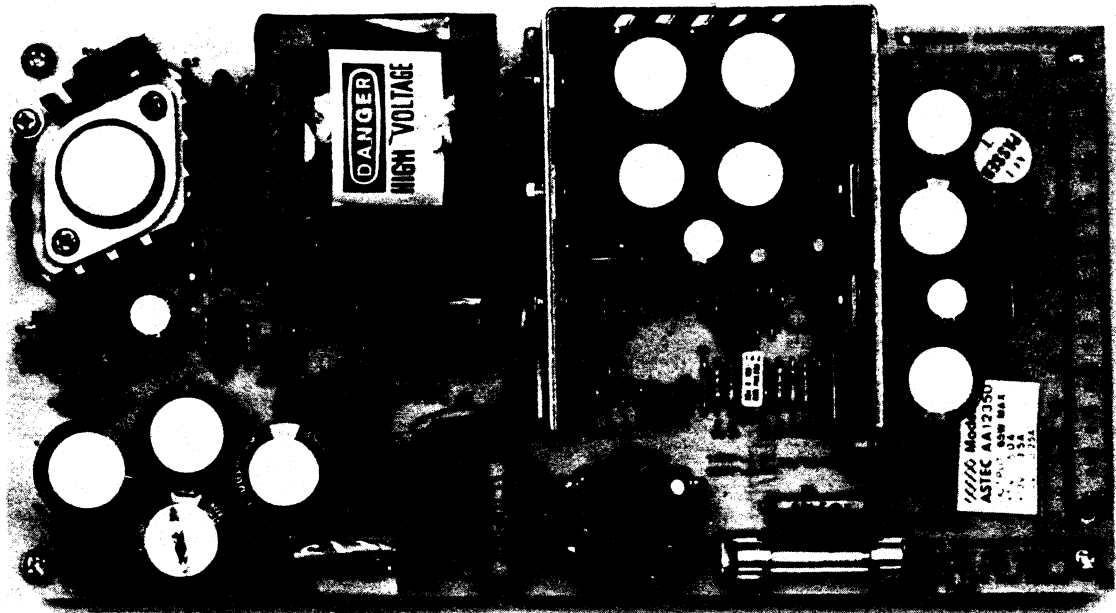

## 220V CONFIGURATION

### Boschert Power Supply

Identified by the word "Boschert" on the component side of the board at lower right and above the fuse and capacitor C2.

Locate a six-inch wire that is soldered to point JP1. If the board is configured for 110V, the other end of the wire is attached to point E1 (labelled 110V).

Unplug the wire from point E1 and plug it into point E2 (labelled 220V). Point E2 is to the left of point E1. The power supply is now configured for 220V use.

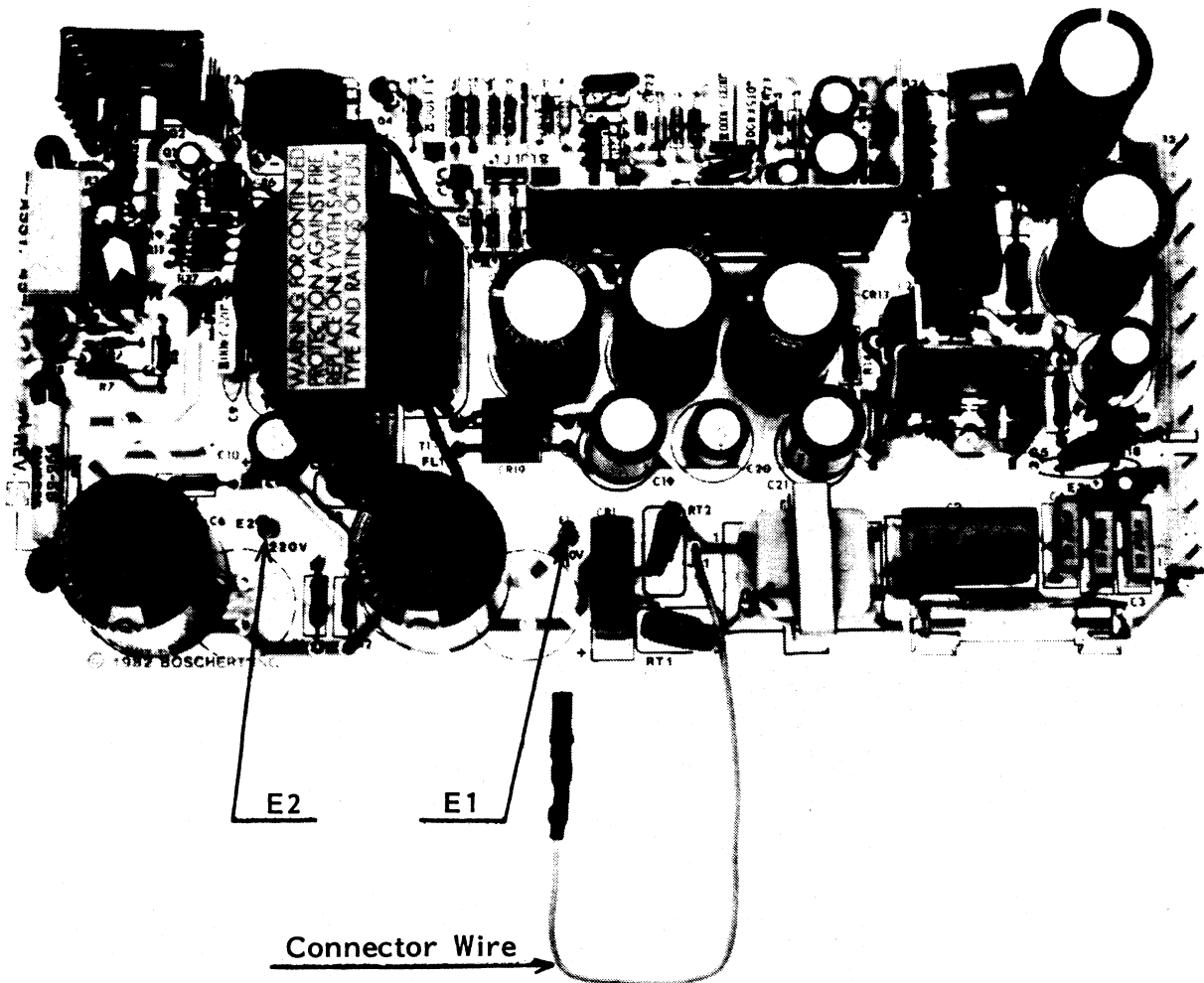

## 220V CONFIGURATION

### Cal D.C. Power Supply

Identified by a bright blue circuit board. A white sticker with "California DC", model, and serial number is located on solder side of board.

There are two ceramic power resistors in the upper right-hand corner of the board. These resistors get quite hot during operation. Wiring should be tied down AWAY FROM THESE COMPONENTS.

Locate a jumper block labelled 115VAC and 230VAC. With the jumper in the 115VAC position the board is configured for 110V.

Remove the jumper from the socket labelled 115VAC and replace it in the socket labelled 230VAC. The power supply is now configured for 220V use.

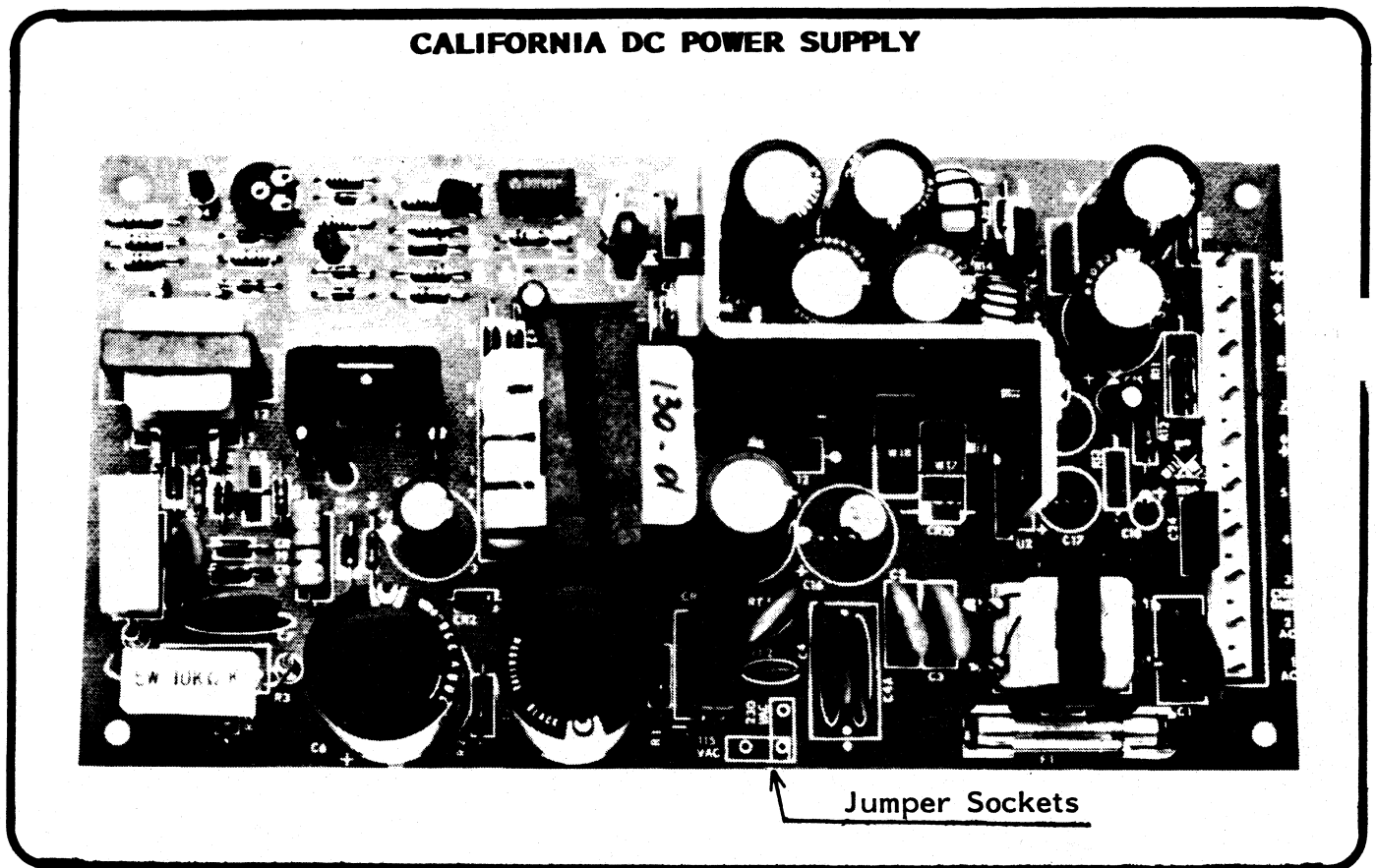

### **8.3 POWER SUPPLY REMOVAL**

1. Turn off the machine and disconnect the AC power (5.1).
2. Remove the chassis hood (5.1).
3. Remove the mainboard (6.7).
4. Remove the four screws that connect the power supply and the back of the chassis. These are easier to remove from outside the back of the chassis than from inside the machine.
5. Remove the power plug from the power supply.
6. Remove the tie wraps from the plastic standoffs.
7. Remove the power supply.

#### **POWER SUPPLY INSTALLATION**

1. Position the power supply inside the chassis so that the four plastic standoffs are aligned with the four mounting holes in the chassis. Be certain that the power connector is on the side nearest the drives.
2. Place the tie wraps on the plastic standoffs.
3. Insert four screws through the rear of the chassis and into the plastic standoffs of the power supply.
4. Tighten the screws securely.
5. Replace the power connector.
6. Replace the mainboard (6.7).
7. Replace the chassis hood (5.1).

## 9.0 DISKETTE DRIVES

### 9.1 INTRODUCTION

All diskette drive types (except the high-density drives in the ROBIE and 4X) are functionally interchangeable between manufacturers.

Because of the number of manufacturers from which Kaypro gets its diskette drives, no attempt is made in this manual to show alignment procedures for each of the drives. If you have access to a drive manual for a particular model, and have the Dysan Alignment Diskette (Dysan's part number: 224/2A) the knowledge, and an oscilloscope, go ahead and align away. Kaypro Corporation's policy is to do no repairs on these components.

However, since the company recognizes the fact that many customers want a KAYPRO computer in which both drives have the same outward appearance, we provide a guide for determining models of diskette drives from the placement of the LED and the drive door closure.

This section also contains diagrams and instructions on jumpering the various models of diskette drives to be used as either A or B (or, in the case of the KAYPRO 10, C) drive.

### DISK DRIVE CLEANING

Generally speaking the majority of people clean disk drives too often. Unless the environment is especially dusty or dirty, under commercial use there is no reason to clean the drives more than twice a year.

Use care in selecting a cleaning kit. Many of the drive head cleaning kits on the market are very abrasive. Cleaning is done by the liquid solution, not by mechanical scrubbing.

**\*\*\*NOTE\*\*\*** The manufacturer (Drivetec) of the high-density drives in the ROBIE, and 4X recommends only four brands of head-cleaning kits for their drives. The letter from Drivetec states:

"THE FOLLOWING CLEANING DISKS HAVE BEEN EVALUATED  
AND ARE RECOMMENDED FOR USAGE ON THE DRIVETEC DISK  
DRIVE WHEN HEAD CLEANING IS DEEMED NECESSARY:

- 1) SCOTCH #7440
- 2) HEAD COMPUTER PRODUCTS 5 1/4 CLEANING DISK
- 3) PERFECT DATA 5 1/4 CLEANING DISK
- 4) FLOPPICLENE 5 1/4 CLEANING DISK"

Refer to the symptom-fix guide for troubleshooting hints relative to the floppy drives, the Winchester hard disk, and the Drivetec (high-density) drives.



## 9.2 WHICH BRAND OF DRIVE IS IT?

The following figures represent the face plates of the different brands of half-height floppy drives that are used in Kaypro computers. The drive door closure and the LED position can be used to reference the drive.

Fig. 9.1, TANDON Half-Height

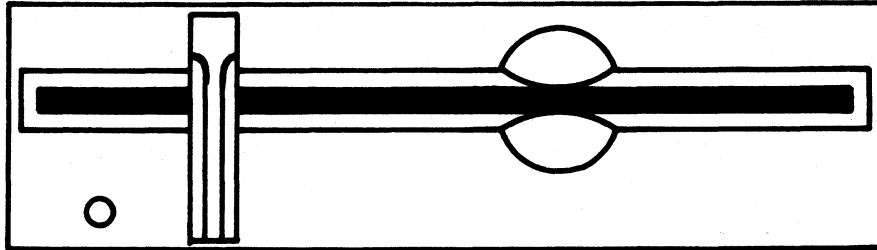

Fig. 9.2, EPSON

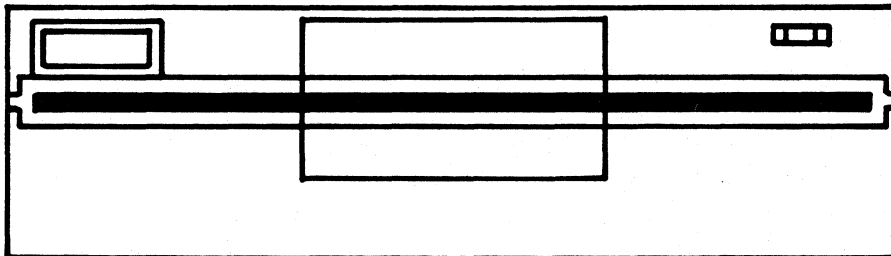

Fig. 9.3, SHUGART

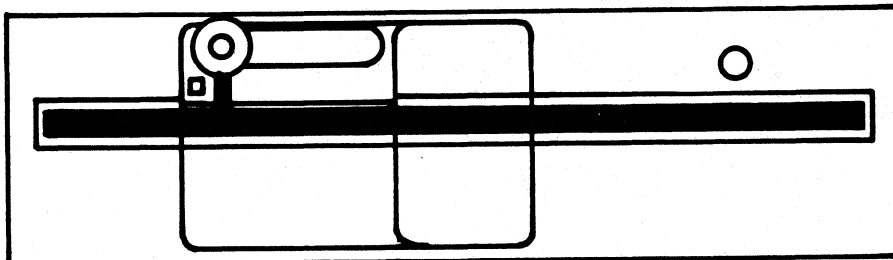

Fig. 9.4, TOKYO ELECTRIC

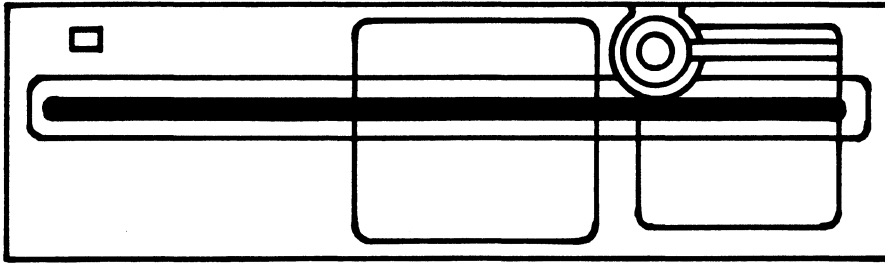

Fig. 9.5, TOSHIBA

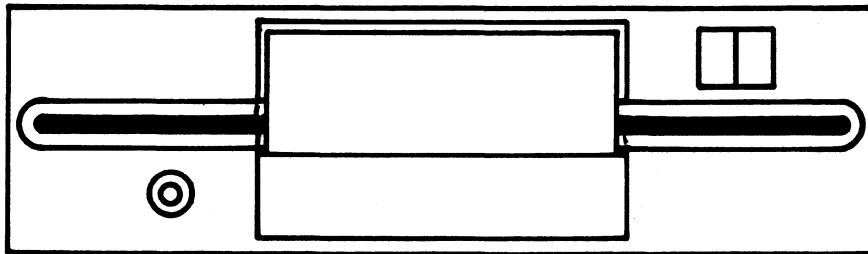

Fig. 9.6, HI-TECH

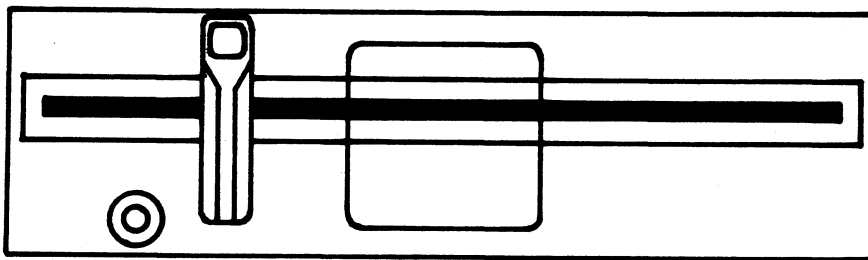

Fig. 9.7, DRIVETEC

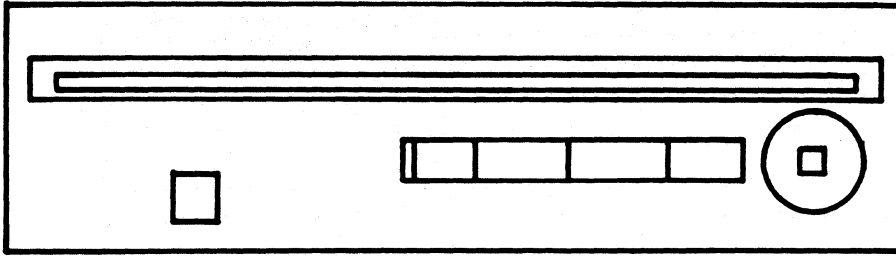
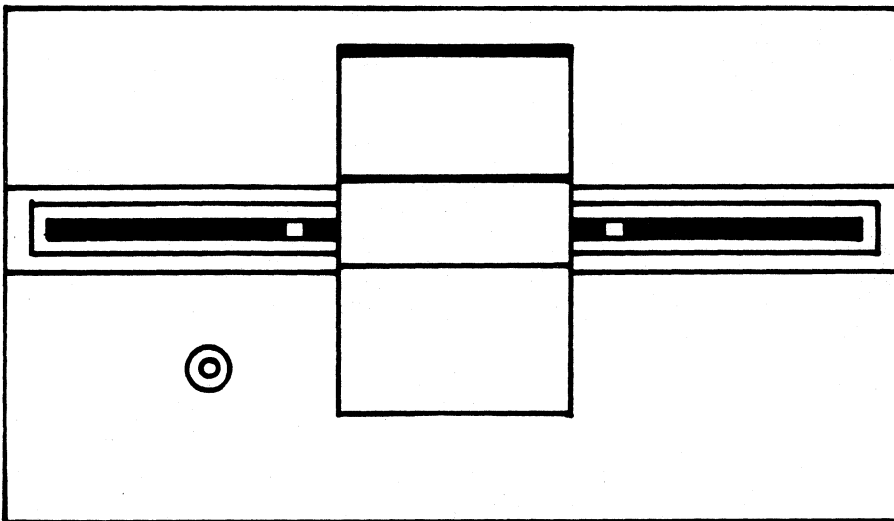
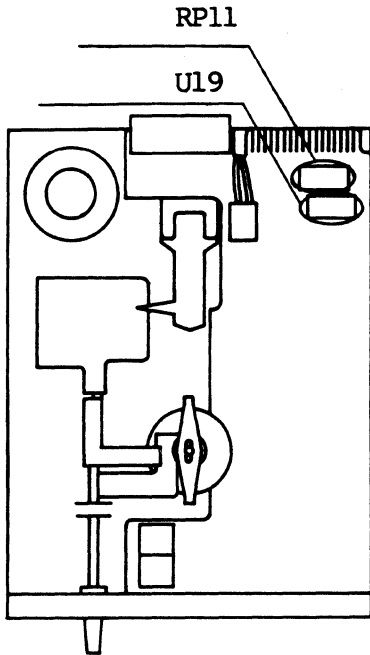

Fig. 9.8, TANDCN Full-Height



### 9.3 JUMPERING DIAGRAMS

Figure 9.8  
Tandon diskette drive



#### TANDON

Used only on KAYPRO 10, Pins 2 and 15 on U19 are jumpered and a 470-ohm terminating resistor pack is inserted in RP11.

Figure 9.9  
Epson diskette drive

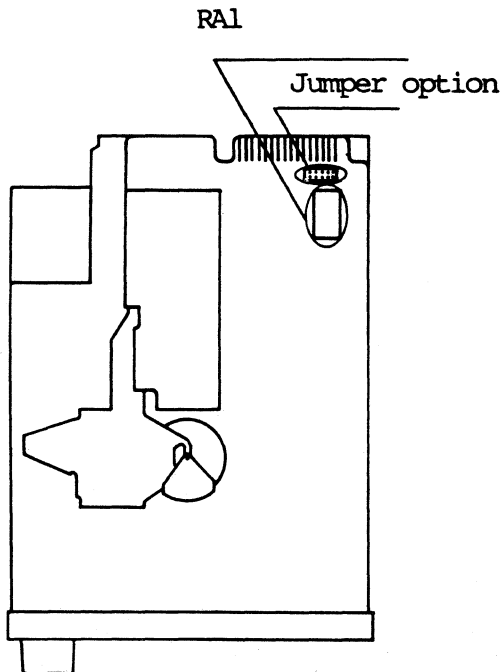

#### EPSON

Next to the connector for the data cable is a black plug with ten pins. These pins are jumpered to change the configuration of the drive. They are MX, 0, 1, 2, 3.

KAYPRO 10: The two pins in the "0" position should be jumpered and a 470-ohm terminating resistor inserted in RAL.

A DRIVE: Jumper the two pins in the "0" position. No terminating resistor is needed.

B DRIVE: Jumper the two pins in the "1" position. Insert a 470-ohm terminating resistor into RAL.

Figure 9.10  
Shugart diskette drive

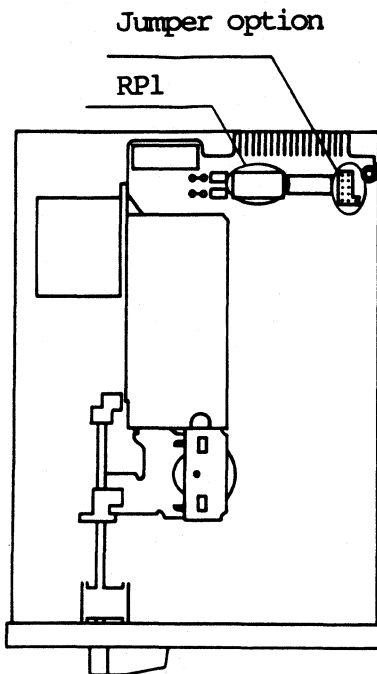

**SHUGART**

Next to the connector for the data cable is a blue plug with eleven pins. These pins are 1, 2, 3, 4, MX.

**KAYPRO 10:** Jumper the two pins in the "1" position. In the "MX" position, there are three pins. Jumper the one in the center and the one on the left of it. Insert a 470-ohm terminating resistor into RPl.

**A DRIVE:** Jumper the two pins in the "1" position. In the "MX" position, jumper the pin in the center and the pin on the left of it. No terminating resistor is necessary.

**B DRIVE:** Jumper the two pins in the "2" position. In the "MX" position, jumper the pin in the center and the pin on the left of it. Insert a 470-ohm terminating resistor into RPl.

Figure 9.11  
Tokyo Electric  
diskette drive

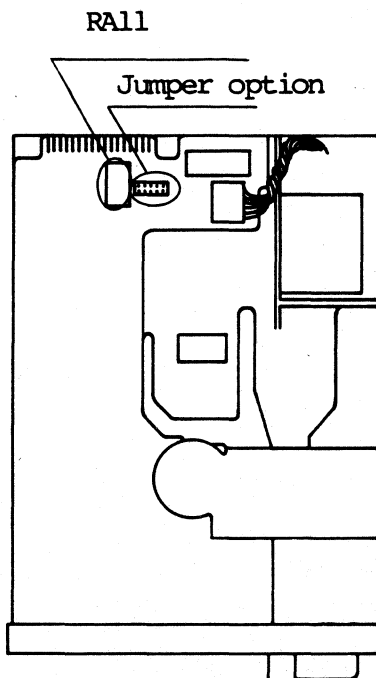

**TOKYO ELECTRIC**

Next to the connector for the data cable is a blue plug with ten pins. These pins are DS0, DS1, DS2, DS3, MX.

**KAYPRO 10:** Jumper the two pins in the "DS0" position. Insert a 470-ohm terminating resistor into RAll.

**A DRIVE:** Jumper the two pins in the "DS0" position. No terminating resistor is necessary.

**B DRIVE:** Jumper the two pins in the "DS1" position. Insert a 470-ohm terminating resistor into RAll.

Figure 9.12  
Toshiba diskette drive

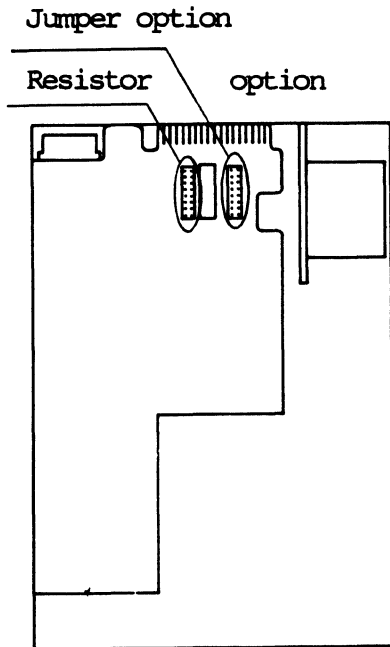

**TOSHIBA**

Next to the connector for the data cable is a black plug with sixteen pins. These are 1, 2, 3, 4, LI, LD, HD, HM. Next to the black plug, is a 470-ohm terminating resistor with the letters "DM" to the left of it. Locate this resistor. On the other side of the resistor is another black plug. This plug has the letters "RM" to the left of it and the letters "PJ5" to the right of it. It has sixteen pins. For the terminating resistor to function, all pins must be jumpered EXCEPT the two next to the letters "RM". When the resistor is not needed, none of the pins should be jumpered.

**KAYPRO 10:** Jumper the two pins in the "1" position, the two pins in the "LD" position, and the two pins in the "HM" position. The terminating resistor is needed.

**A DRIVE:** Jumper the two pins in the "1" position, the two pins in the "LD" position, and the two pins in the "HM" position. The terminating resistor is not needed.

**B DRIVE:** Jumper the two pins in the "2" position, the two pins in the "LD" position, and the two pins in the "HM" position. The terminating resistor is needed.

Figure 9.13  
Hi-Tech diskette drive

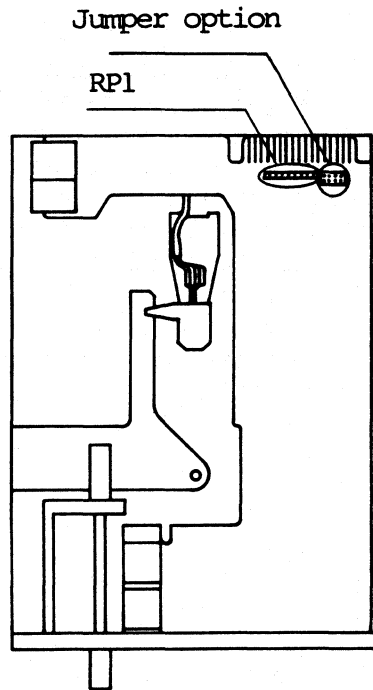

**HI-TECH**

Next to the connector for the data cable is a black plug with eight pins. These pins are DS0, DS1, DS2, DS3.

KAYPRO 10: Jumper the two pins in the "DS0" position. Insert a 470-ohm SIP terminating resistor into RP1.

A-DRIVE: Jumper the two pins in the "DS0" position. No terminating resistor is necessary.

B-DRIVE: Jumper the two pins in the "DS1" position. Insert a 470-ohm terminating resistor into RP1.

Figure 9.14  
Tandon full-height  
diskette drive

Option shunt 1E

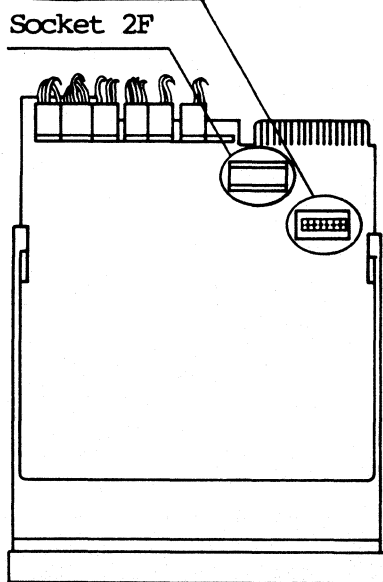

**TANDON**

Used only in KAYPRO 2 AND KAYPRO 4.

A DRIVE: Pins 1-14 and 2-13 should be jumpered in option shunt block 1E.

B DRIVE: Pins 1-14 and 3-12 should be jumpered in option shunt block 1E. Insert a 470-ohm terminating resistor into socket 2F.

## 9.4 HIGH-DENSITY (DRIVETEC) DRIVES

The high-density diskette drives are currently being offered in the KAYPRO ROBIE, and KAYPRO 4X. These are 5-1/4 inch, double-sided drives with 192 tracks per inch. Each drive has 160 cylinders with a total of 320 tracks and a formatted storage capacity of 2.6 megabytes.

### HIGH-DENSITY DISKETTES

The diskettes used with the high-density drives MUST be pre-formatted 17 sector, 192 TPI diskettes.

### DRIVE CONFIGURATION

Next to the connector for the data cable is a drive select switch— DS1 through DS4.

A DRIVE: DS1 should be in the "on" position. All other switches should be in the "off" position.

DRIVE: DS2 should be in the "on" position. All other switches should be in the "off" position.

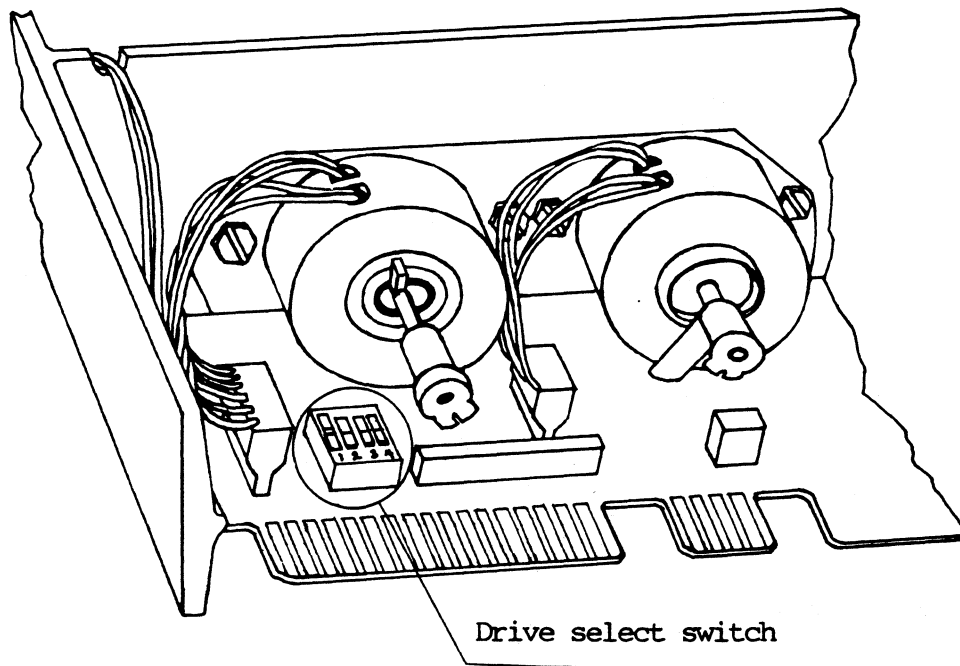



## 10.0 HARD DISK DRIVES (KAYPRO 10)

### 10.1 INTRODUCTION

Kaypro Corporation uses hard disk drives from a number of different manufacturers. As with the diskette drives, all models of hard disk drives are functionally interchangeable.

No adjustments are meant to be made by dealers (or are made by Kaypro technicians, for that matter) on these hard drives. And, since recovering information from a hard disk which has "crashed" requires a clean room, no directions for performing such an operation are included in this manual. Be aware that true head crashes are very rare occurrences, however—most hard disk problems can be corrected without the need to replace the drive itself. (See the symptom-fix guide.) We cannot stress strongly enough that dealers instruct their customers to ALWAYS back up their data while working on a hard disk. In many cases NOTHING can be done about the loss of data in a hard-drive failure.

## 10.2 DESCRIPTION

The hard disk drives used in the KAYPRO 10 are industry standard, 5-1/4 inch half-height drives offering Winchester technology. This technology includes sealed media and drive heads, with an air filtration system that prevents contamination. Since the drives are sealed, there are no dealer serviceable components on the drive. The only authorized dealer service to the hard disk drives is drive configuration.

### 10.3 HARD DRIVE CONFIGURATION MICROSCIENCE

Figure 10.1  
Microscience  
9 Position Switch



There are two types of drive selection switch banks available on Microscience drives. One type has nine (9) switches and one type has ten (10) switches. These switches are located on the drive PCB next to the power plug.

9 POSITION SWITCH: Pins 1, 2, and 4 should be in the "up" position .

Figure 10.2  
Microscience  
10 Position Switch



10 POSITION SWITCH: Pins 1, 3, 4, and 10 should be in the up position.

Refer to Figures 10.1 and 10.2 for Microscience drive configuration.

### SEAGATE

Figure 10.3  
Seagate Hard Drive  
Option shunt block

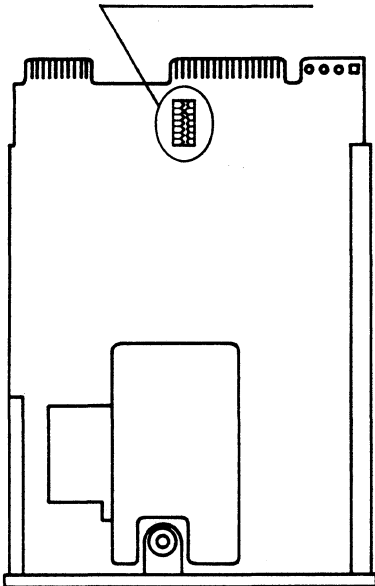

Next to the connector for the data cable, is a 16 pin option shunt block. Pins 7 and 10 should be jumpered.

Refer to figure 10.3 for Seagate drive configuration.

#### **10.4 HARD DRIVE OR FLOPPY DRIVE REMOVAL FOR KAYPRO 10**

For all hard drives and all diskette drives used in KAYPRO 10 computers.

Note: If the KAYPRO 10 has an Epson or Tokyo Electric diskette drive, it will be necessary to tilt the drive unit at an angle while removing or installing the drive. Refer to section 9.2 to determine the brand of drive.

Note: As you remove the cables on the KAYPRO 10, it's a good idea to label them. This will insure that they get replaced correctly. Also, the end of the data cable that has a different color wire (usually red) goes to pin #1 on the connector.

1. Turn off the machine and disconnect the AC power (5.1).
2. Remove the chassis hood (5.1).
3. Remove the two diagonal braces from the right side of the chassis.
4. Tilt the machine up so that the front of the machine is sitting on the work surface and parallel to the floor.
5. Remove the six screws from the bottom of the chassis that are under the drives. Set the machine back down.
6. Remove the ribbon cables from the mainboard.
7. Slide entire drive shield unit slightly to the rear, to make room for the face of the floppy to clear the opening.
8. Lift entire drive shield unit slightly and slide out the side of the chassis.

#### **REMOVING THE DRIVES FROM THE DRIVE SHIELD**

1. Remove the ribbon cables, power plug and the ground wire from the back of the drive (hard drive or floppy). Label these.
2. Remove the two screws that attach the bottom of the drive to the drive shield (hard drive or floppy).
3. Remove the two screws that attach the top of the drive to the drive shield.
4. Slide drive out through the front of the drive shield.

## HARD DRIVE OR FLOPPY INSTALLATION FOR KAYPRO 10

1. Configure the new drive. Refer to page 10--3 for the hard drive, pages 9--5 to 9--7 for the floppy drive.
2. Slide the drive into the shield so that the mounting holes in the drive are aligned with those in the shield.
3. Insert two screws through the top of the shield and into the mounting holes of the drive.
4. Tighten these securely.
5. Insert two screws through the bottom of the shield and into the mounting holes of the drive.
6. Tighten these securely.
7. Replace the ribbon cable(s), power plug and ground wire.
8. Slide the entire drive shield unit into the chassis.
9. Align the mounting holes in the drive shield with those in the chassis.
10. Insert the six screws through the mounting holes and tighten securely.
11. Replace the two diagonal braces.
12. Replace the ribbon cable(s) on the mainboard.
13. Replace the chassis hood.

## 11.0 HARD DRIVE CONTROLLER BOARD

### 11.1 DESCRIPTION

The hard disk controller board used in the KAYPRO 10 is a Western Digital board, and is not dealer-serviceable.

## **11.2 REMOVAL/INSTALLATION INSTRUCTIONS**

### **HARD DRIVE CONTROLLER BOARD REMOVAL**

1. Turn off the machine and disconnect AC power (5.1).
2. Remove chassis hood (5.1).
3. Remove the two diagonal braces from the right side of the machine.
4. Remove the power plug and the three ribbon cables from the hard disk controller board. Label these to insure correct replacement.
5. Remove the three screws that attach the hard disk controller board and the drive shield.
6. Remove the board.

### **HARD DRIVE CONTROLLER BOARD INSTALLATION**

1. Position the hard disk controller board so that the mounting holes in the board are aligned with the holes in the drive shield.
2. Insert the three screws and tighten securely.
3. Replace the power plug and the three ribbon cables.
4. Replace the two diagonal braces.
5. Replace the chassis hood (5.1).

## **12.0 INTERFACE BOARD, KAYPRO 10**

### **12.1 DESCRIPTION**

The interface board that is used on the KAYPRO 10 is the interface between the mainboard and the hard drive controller board. This board is not dealer serviceable.



## **12.2 INTERFACE BOARD REMOVAL**

1. Turn off the machine and disconnect the AC power (5.1).
2. Remove the chassis hood (5.1).
3. Remove the mainboard (6.7).
4. Remove the two ribbon cables from the interface board.
5. Remove the four screws that attach the interface board and the drive shield.
6. Remove the interface board.

### **INTERFACE BOARD INSTALLATION**

1. Position the interface board so that the mounting holes on the board are aligned with the holes on the drive shield.
2. Insert four screws and tighten securely.
3. Replace the two ribbon cables.
4. Replace the mainboard (6.7).
5. Replace the chassis hood (5.1).

## 13.0 KEYBOARDS

The 76-key alphanumeric, detachable keyboard is connected to the computer by a four-wire cable and is powered by +5 VDC through the cable. The CAPS LOCK indicator light allows a quick check on whether the keyboard is receiving power.

The impedance of the connecting cable can be a critical factor in proper operation of the computer. Replacement of the standard cable with a phone cord can create malfunctions in signal transmission to the computer. This is because the wire in phone cords is too small; therefore, the impedance over the total length of the cord can be too high for reliable operation.

Wire in the standard keyboard cable is 28-gage copper, and the cable length is six feet. Should you desire a longer keyboard cable, restrict the length to not more than twelve feet, and use wire no smaller than 28 gauge.

### Keyboard Cable Pinouts

Pin 4 (Black) - Serial Data out (to keyboard), TTL level.  
Pin 3 (Red) - Ground  
Pin 2 (Green) - Serial data in (from keyboard), TTL level.  
Pin 1 (Yellow) - +5 VDC

## **14.0 KAYPRO ROBIE REMOVAL/INSTALLATION INSTRUCTIONS**

### **14.1 CHASSIS COVER REMOVAL**

1. Turn off the machine and disconnect the AC power(5.1).
2. Remove the four screws securing the top chassis cover (two on each side of the machine).
3. Remove the eight screws securing the bottom chassis cover (four on each side of the machine).
4. Remove the two sections of the chassis cover from the machine.

### **CHASSIS COVER REPLACEMENT**

1. Place the lower chassis cover on the machine and align the eight mounting holes with the mounting holes in the sides of the machine.
2. Insert the eight screws into the mounting holes and tighten securely.
3. Place the top chassis cover on the machine and align the four mounting holes with the mounting holes in the sides of the machine.
4. Insert the four screws into the mounting holes and tighten securely.

## 14.2 DISKETTE DRIVE REMOVAL

1. Remove the top chassis cover (5.1).
2. Remove the drive support unit from the chassis. There are three screws in the front and three screws in the rear.
3. Remove the ribbon cable and the power plugs from the drives.
4. Lift the drive support unit (drives still attached) off the chassis.
5. To remove either drive from the drive support unit, turn the unit over and remove the four screws that attach the specific drive to the support unit.

## DISKETTE DRIVE REPLACEMENT

1. Align the drive mounting holes with the mounting holes in the drive support unit.
2. Insert four screws into the drive support unit and into the drive. Tighten these screws securely.
3. Set the drive support unit on the chassis and align the mounting holes in the support unit with those in the chassis.
4. Insert three screws into the front mounting holes and three screws into the rear mounting holes. Tighten these securely.
5. Replace the ribbon cable and the power plugs on the drives.

## 15.0 TROUBLESHOOTING

### 15.1 INTRODUCTION

The symptom—fix guide's information is based on our experience repairing Kaypro computers. The guide is a summary of the records that Kaypro Repair maintains on each computer received.

\*\*\*\*\*

Fixes for each problem noted are presented in **descending** order of occurrence.

\*\*\*\*\*

## 15.2 KAYPRO 2 AND 4 SYMPTOM—FIX GUIDE

CONDITION	POSSIBLE CAUSE	RECOMMENDED ACTION
No power, no lights, no video	Power cord not plugged in	Check all cord connections
	Fuse is blown	Replace fuse
	Mainboard not getting power	Check harness connections; check for proper voltages; replace either harness or power supply
	Defective mainboard	Replace mainboard
	Defective fuse holder	Replace fuse holder
	Power switch shorted internally	Replace power switch
	Power supply jumpered for wrong supply	Correct jumpering on power supply
	Defective power supply	Replace power supply
Fuse blows when power is turned on	Defective power supply	Disconnect all modules from power supply; replace power supply if fuse still blows
	One module has a short	Disconnect all modules, replace fuse, and re-connect modules, one at a time, until fuse blows. Replace that module
	Defective harness	Replace harness
High-pitched squeal or "chirp"	One module is shorted	Unplug modules, one at a time, from the harness. Replace the module whose unplugging causes the noise to stop

KAYPRO 2 AND 4 SYMPTOM—FIX GUIDE (CONT'D)

CONDITION	POSSIBLE CAUSE	RECOMMENDED ACTION
Power LED flickers	Shorted module	Disconnect modules from power, one at a time, until LED stays on; replace module whose unplugging caused LED to stay on.
	Defective power supply	Replace power supply
	Defective harness	Replace harness
No video display, or poor quality display	Brightness not adjusted	Turn up brightness knob on rear of chassis; adjust brightness pot on CRT board, if necessary
	CRT not connected	Check all connections to CRT; be sure plug on rear of CRT tube is square
	Defective CRT	Replace CRT assembly
	Defective mainboard	Replace mainboard
	Defective power supply	Replace power supply
	Defective harness	Replace harness
	Video is on, but screen is filled with "garbage" characters	Defective mainboard
Reset harness shorted to chassis		Check lugs of reset button for grounding to inside of chassis
Defective reset harness		Replace reset harness

KAYPRO 2 AND 4 SYMPTOM—FIX GUIDE (CONT'D)

CONDITION	POSSIBLE CAUSE	RECOMMENDED ACTION
"Raster" (horizontal lines) on video	Brightness not adjusted properly	Turn up brightness knob on back of chassis; adjust brightness pot on CRT board if necessary
	Loose connection from mainboard or power supply	Check black plug from power supply to CRT board, 4-pin jumper from main board to CRT board; check that plug on rear of CRT tube is square
Strange video image	Short in brightness-adjusting knob	Check for shorts between wires in rear of brightness-adjusting knob
	Defective mainboard	Replace mainboard
Missing characters on video display	Defective mainboard	Replace mainboard
	Defective CRT	Replace CRT assembly
Will not boot	Defective diskette	Change diskettes
	Diskette has no system image	Change diskettes; use a diskette with a known good system image
	Wrong CP/M for model of machine	Check that you're not trying to boot a KP 2 with a KP 4 CP/M (KP 4 WILL boot a KP 2 CP/M)
	Defective drive B	Unplug data cable from drive B, and reset machine; if it boots, replace drive B
	Defective mainboard	Replace mainboard
	Defective drive A	Replace drive A
	Defective data cable	Replace data cable



**KAYPRO 2 AND 4 SYMPTOM—FIX GUIDE (CONT'D)**

CONDITION	POSSIBLE CAUSE	RECOMMENDED ACTION
Both drive LEDs are on, won't boot	Problem on power-up	Reset machine
	Diskette has no CP/M	Try known good sysgenned diskette
	Defective mainboard	Replace mainboard
	Select jumpers on drives incorrect	Check select jumpers
Drive A LED only on during reset	Drive select jumpering incorrect	Check jumpering on drive A
No LED on drive A at any time	Data cable poorly connected	Check all connections on data cable
	Defective data cable	Replace data cable
	Defective drive A	Replace drive A
	Defective mainboard	Replace mainboard
Computer boots CP/M, but no A> prompt appears	Defective diskette	Try known good, sysgenned diskette
	Defective mainboard	Replace mainboard
Rattling sound from drive when accessing	Defective drive	Replace the diskette drive
	Defective mainboard	Replace mainboard

## KAYPRO 2 AND 4 SYMPTOM—FIX GUIDE (CONTINUED)

CONDITION	POSSIBLE CAUSE	RECOMMENDED ACTION
Drive will not step through all tracks on diskette	Drive connectors loose	Check all connectors on rear of drive, esp. P12 (Tandon drives)
	Defective mainboard	Replace mainboard
	Defective drive	Replace diskette drive
	Defective data cable	Replace data cable
Errors on either drive during COPY	Defective diskette	Change the diskette (if problem is on drive B, insert another blank diskette; if on drive A, try to copy from a new master)
	Defective disk drive	Replace diskette drive
	Defective mainboard	Replace mainboard
No output to parallel printer	No power to printer	Check that printer is plugged in, and selected
	Poor cable connection	Check all cable connections from computer to printer
	Printer is assigned as serial by STAT	Use STAT to assign printer device as parallel, type: STAT LST:=LPT:
	Defective mainboard	Replace mainboard
No output to serial printer	No power to printer	Check that printer is plugged in and selected
	Poor cable connection	Check all cable connections from computer to printer; also check serial port connector pins for contamination
	Printer is assigned as parallel by STAT	Use STAT to assign printer device to serial; type: STAT LST:=TTY:

KAYPRO 2 AND 4 SYMPTOM—FIX GUIDE (CONTINUED)

CONDITION	POSSIBLE CAUSE	RECOMMENDED ACTION
No output to serial printer (cont'd)	Baud rate of printer does not match baud rate of computer	Use CONFIG to set baud rate for serial port
	Defective power supply	Check voltages (esp.-12 V) at power supply output; replace power supply
	Defective harness	Check voltages (esp.-12V) at main board power connector; replace harness
	Defective mainboard	Replace mainboard
No characters on video when keys struck on keyboard	Defective keyboard coil cord	Replace coil cord
	Defective keyboard	Replace keyboard
	Keyboard connector on mainboard defective	Check for shorted contacts on keyboard plug; esp. soldering to main board
	Defective mainboard	Replace mainboard
Wrong characters or too many characters appear when a key is struck	Defective keyboard	Replace keyboard
	Defective mainboard	Replace mainboard (if "^^@^@" appears, replace 8116 IC on mainboard)

### 15.3 KAYPRO 10 SYMPTOM—FIX GUIDE

#### IMPORTANT NOTE

\*\*\*\*\*

Do not proceed with troubleshooting a Kaypro 10 until you verify that the computer has eprom number 81-302-x (installed at the factory), or has been upgraded in the field with kit number 31-303 (consisting of eprom number 81-302-x, a modified interface board, and a utilities reload diskette.)

CONDITION	POSSIBLE CAUSE	RECOMMENDED ACTION
No power, no lights, no video	Power cord not plugged in	Check all cord connections
	Fuse is blown	Replace fuse
	Mainboard not getting power	Check harness connections, then check for proper voltages from power supply; replace either harness or power supply
	Defective mainboard	Replace mainboard
	Defective fuse holder	Replace fuse holder
	Power switch shorted internally	Replace power switch
	Power supply jumpered for wrong supply voltage	Correct jumpering on power supply
	Defective power supply	Check for proper voltage output at power supply harness connector; replace power supply
	Defective harness	Replace harness
Fuse blows when power turned on	Defective power supply	Replace power supply
	One module has a short	Disconnect all modules, replace fuse, and re-connect one by one until fuse blows again; replace it
	Defective harness	Replace harness

## KAYPRO 10 SYMPTOM—FIX GUIDE (CONT'D)

CONDITION	POSSIBLE CAUSE	RECOMMENDED ACTION
High-pitched squeal or "chirp" upon power-on	One module is shorted	Unplug modules, one at a time, from the harness. Replace the module whose unplugging causes the noise to stop.
Power LED flickers	Shorted module	Disconnect modules from power one at a time until LED stays on; replace module whose unplugging causes LED to stay on
	Defective power supply	Replace power supply
	Defective harness	Replace harness
No video display, or poor quality display	Brightness not adjusted	Turn up brightness knob on rear of chassis; turn up brightness pot on CRT board, if necessary
	CRT not connected	Check all connections to CRT; ensure CRT tube plug is square
	Defective CRT	Replace CRT assembly
	Defective mainboard	Replace mainboard
	Defective power supply	Replace power supply
	Defective harness	Replace harness
Extra pixels on video	Defective mainboard	Replace mainboard
	Defective CRT	Replace CRT assembly
Inverse video only	Defective mainboard	Replace mainboard
	Defective CRT	Replace CRT assembly

### KAYPRO 10 SYMPTOM—FIX GUIDE (CONT'D)

CONDITION	POSSIBLE CAUSES	RECOMMENDED ACTION
No graphics on video	Damaged system image	Run PUTSYS and PUTOWL
	Defective mainboard	Replace mainboard
	Defective CRT	Replace CRT assembly
No video; drives running	Poor cable connection	Check all cable connections, (esp. to/from video harness plug)
	Defective mainboard	Replace mainboard
	Defective CRT	Replace CRT assembly
	Elston CRT: fuse blown	Check continuity of pico-fuse on Elston video board (just above power connector) If open, replace
Hard drive boots, but no cursor on video	Defective system image	Run PUTSYS and PUTOWL from the diskette drive, push RESET
	Defective mainboard	Replace mainboard
Diskette drive boots, but no cursor on video	Defective system image on diskette	Run GENFLPY on the diskette; push RESET
	Defective mainboard	Replace mainboard
	Defective drive	Replace diskette drive
Diskette drive won't boot; or BDOS error on diskette drive	Diskette not centered	Remove diskette, center diskette in its jacket; try again
	No system image on diskette	Run GENFLPY on the diskette; push RESET
	Defective diskette	Try a known good diskette with a known good system image

## KAYPRO 10 SYMPTOM—FIX GUIDE (CONT'D)

CONDITION	POSSIBLE CAUSE	RECOMMENDED ACTION
Diskette drive won't boot; or BDOS errors	Poor cable connection	Check all cable connections; esp. those to/from drives and the controller board
	No system image	Run GENFLPY
	Incorrect cable orientation	Verify that all cables are oriented properly
	Defective mainboard	Replace mainboard
	Defective drive	Replace diskette drive
Diskette drive won't format a disk	Diskette off center	Ensure that diskette is centered within its jacket
	Defective diskette drive	Replace diskette drive
	Defective mainboard	Replace mainboard
Diskette drive has BDOS errors or won't work if warm	Defective drive heads	Replace diskette drive
	Defective mainboard	Replace mainboard
Diskette drive makes a rattling noise, and won't boot	Defective diskette drive	Replace diskette drive
	Defective mainboard	Replace mainboard
High-pitched whine when diskette drive runs	Defective diskette drive ("singing heads")	Replace diskette drive

## KAYPRO 10 SYMPTOM—FIX GUIDE (CONT'D)

CONDITION	POSSIBLE CAUSE	RECOMMENDED ACTION
Hard drive will not boot; or boots with "System Status 02" ("Read Fault") message	Machine not upgraded	Verify installation of eeprom number 81-302-x (at the factory), or kit 81-303; install if needed
	Poor cable connection	Check all cable connections
	Incorrect cable orientation	Verify that all cables are oriented properly
	System image degraded	Boot on a disk in the diskette drive; then log onto hard drive. Run FINDBAD (or CHECK on cylinders 0 and 1) if no errors are found, run PUTSYS and PUTOVL
	Defective controller board	Replace controller board
	Degraded format on hard disk	Boot on a disk in the diskette drive; run FORMAT on entire hard drive; then run PUTSYS and PUTOVL
	Defective mainboard	Replace mainboard
	Defective hard drive	Replace hard drive
	Defective power supply	Replace power supply

---

Except in the case of an obvious head crash or brake assembly failure, ALWAYS suspect other modules first when a defect appears to be within the hard drive.

---

No output to parallel printer	No power to printer	Check that printer is plugged in, and selected
	Poor cable connection	Check all cable connections from computer to printer
	Printer is assigned as serial by STAT	Use STAT to assign printer device as parallel; type: STAT LST:=-LPT:
	Defective mainboard	Replace mainboard

---



KAYPRO 10 SYMPTOM—FIX GUIDE (CONT'D)

CONDITION	POSSIBLE CAUSE	RECOMMENDED ACTION
No output to serial printer	No power to printer	Check that printer is plugged in and selected
	Poor cable connection	Check all cable connections from computer to printer; also check serial port connector pins for contamination
	Printer is assigned as parallel by STAT	Use STAT to assign printer device to serial; type: STAT LST:=TTY:
	Baud rate of printer does not match baud rate of computer	Use CONFIG to set baud rate for serial port
	Defective power supply	Check voltages (esp.-12 V) at supply output; replace supply
	Defective harness	Check voltages (esp.-12V) at main board power connector; replace harness
	Defective mainboard	Replace mainboard

## 15.4 KAYPRO ROBIE SYMPTOM—FIX GUIDE

CONDITION	POSSIBLE CAUSE	RECOMMENDED ACTION
No power, no lights, no video	Power cord not plugged in	Check all cord connections
	Fuse is blown	Replace fuse
	Mainboard not getting power	Check harness connections; check for proper voltages; replace either harness or power supply
	Defective mainboard	Replace mainboard
	Defective power supply	Replace power supply
	Defective harness	Replace harness
Fuse blows when power is turned on	Defective power supply	Disconnect all modules from power supply; replace power supply if fuse still blows
	One module has a short	Disconnect all modules, replace fuse, and re-connect modules, one at a time, until fuse blows. Replace that module
	Defective harness	Replace harness
High-pitched squeal or "chirp"	One module is shorted	Unplug modules, one at a time, from the harness. Replace the module whose unplugging causes the noise to stop
No video display	Brightness not adjusted	Turn up brightness knob on rear of chassis; turn up brightness pot on CRT board, if necessary
	CRT not connected	Check all connections to CRT; be sure plug on rear of CRT tube is square

**KAYPRO ROBIE SYMPTOM—FIX GUIDE (CON'T.)**

CONDITION	POSSIBLE CAUSE	RECOMMENDED ACTION
No video display	Defective CRT	Replace CRT assembly
	Defective mainboard	Replace mainboard
	Defective power supply	Replace power supply
	Defective harness	Replace harness
Video is on, but screen is filled with "garbage" characters	Defective mainboard	Replace mainboard
	Reset harness shorted to chassis	Check lugs of reset button for grounding to inside of chassis
	Defective reset harness	Replace reset harness
"Raster" (horizontal lines) on video	Brightness not adjusted properly	Turn up brightness knob on back of chassis; adjust brightness pot on CRT board if necessary
	Loose connection from mainboard or power supply	Check black plug from power supply to CRT board, 4-pin jumper from mainboard to CRT board; check that plug on rear of CRT tube is square
Strange video image	Defective mainboard	Replace mainboard
Missing characters on video display	Defective mainboard	Replace mainboard
Will not boot	Defective diskette	Change diskettes
	Diskette has no system image	Change diskettes; use a diskette with a known good system image
	Wrong diskette for model of machine	ROBIE will only boot on 17 sector, 192 TPI diskettes
	Defective drive B	Unplug data cable from drive B, and reset machine; if it boots, replace B drive

**KAYPRO ROBIE SYMPTOM—FIX GUIDE (CON'T.)**

CONDITION	POSSIBLE CAUSE	RECOMMENDED ACTION
Will not boot	Defective mainboard	Replace mainboard
	Defective drive A	Replace drive A
	Defective data cable	Replace data cable
Both drive LEDs are on, won't boot	Problem on power-up	Reset machine
	Diskette has no CP/M	Try known good sysgenned diskette
	Defective mainboard	Replace mainboard
	Select jumpers on drives incorrect	Check select jumpers
Drive A LED only on during reset	Drive select jumpering incorrect	Check jumpering on drive A
No LED on drive A at any time	Data cable poorly connected	Check all connections on data cable
	Defective data cable	Replace data cable
	Defective drive A	Replace drive A
	Defective mainboard	Replace mainboard
Computer boots CP/M, but no master menu appears	Defective diskette	Try known good, sysgenned diskette
	Defective drive A	Replace drive A
	Defective mainboard	Replace mainboard
Rattling sound from drive when accessing	Defective drive	Replace the diskette drive
	Defective mainboard	Replace mainboard

**KAYPRO ROBIE SYMPTOM—FIX GUIDE (CONT'D.)**

CONDITION	POSSIBLE CAUSE	RECOMMENDED ACTION
Drive will not step through all tracks on diskette	Drive connectors loose	Check all connectors on rear of drive
	Defective mainboard	Replace mainboard
	Defective drive	Replace diskette drive
	Defective data cable	Replace data cable
Errors on either drive during COPY	Defective diskette	Change the diskette (if problem is on drive B, insert another blank diskette; if on drive A, try to copy from a new master)
	Defective disk drive	Replace diskette drive
	Defective mainboard	Replace mainboard
No output to parallel printer	No power to printer	Check that printer is plugged in, and selected
	Poor cable connection	Check all cable connections from computer to printer
	Printer is assigned as serial by STAT	Use STAT to assign printer device as parallel, type: STAT LST:=LPT:
	Defective mainboard	Replace mainboard
No output to serial printer	No power to printer	Check that printer is plugged in and selected
	Poor cable connection	Check all cable connections from computer to printer; also check serial port connector pins for contamination

### KAYPRO ROBIE SYMPTOM—FIX GUIDE (CONT'D.)

CONDITION	POSSIBLE CAUSE	RECOMMENDED ACTION
No output to serial printer (cont'd)	Printer is assigned as parallel by STAT	Use STAT to assign printer device to serial; type: STAT LST:=TTY:
	Baud rate of printer does not match baud rate of computer	Use CONFIG to set baud rate for serial port
	Defective power supply	Check voltages (esp.-12 V) at power supply output; replace power supply
	Defective harness	Check voltages (esp.-12V) at main board power connector; replace harness
	Defective mainboard	Replace mainboard
No characters on video when keys struck on keyboard	Defective keyboard coil cord	Replace coil cord
	Defective keyboard	Replace keyboard
	Keyboard connector on mainboard defective	Check for shorted contacts on keyboard plug; esp. soldering to main board
	Defective mainboard	Replace mainboard
Wrong characters	Defective keyboard	Replace keyboard

## 15.5 KAYPRO 2/84 AND KAYPRO 2X SYMPTOM—FIX GUIDE

See KAYPRO 2 AND 4 SYMPTOM—FIX GUIDE for the 2/84. The problems and solutions will not be different.

For troubleshooting information on the KAYPRO 2X, see the KAYPRO 2 AND 4 SYMPTOM—FIX GUIDE for all problems.

## 15.6 KAYPRO 4X SYMPTOM-FIX GUIDE

For help in troubleshooting the KAYPRO 4X, see the KAYPRO ROBIE SYMPTOM-FIX GUIDE.



## 16.0 KAYPRO SYSTEM I/O

### 16.1 VIDEO COMMAND PROTOCOL

The Kaypro video section was originally designed to imitate most of the control sequences of a Lear-Siegler ADM-3A terminal. For most commercial software, this meant that you could "install" or customize the display characteristics by choosing ADM-3A from the menu.

The above is no longer true for the current Kaypro line. The change to graphics and the differences in cursor control keys caused the change.

For custom software or those instances where there is no choice of "ADM-3A" on the menu, the complete command protocol for the KAYPRO 2, 4, or 10 is:

#### Control Characters

Action	VERSION 2.2F AND LOWER		VERSION 2.2G	
	Dec	Hex	Dec	Hex
Ring Bell	07	07		
Cursor left (non-destructive)	08	08	19	13
Cursor Right	12	0C	04	04
Cursor Down	10	0A	24	18
Cursor Up	11	0B	05	05
Erase to end of screen	23	17		
Erase to end of line	24	18		
Clear screen, home cursor	26	1A		
Home cursor	30	1E		
			Remaining codes are the same as in 2.2G (and lower).	

#### ESCape Sequences

Insert line	ESCape,R
Delete line	ESCape,E
Cursor address	ESCape,=,row+32,col+32

\* Additionally, the following codes apply to: KAYPRO 2/84, 2X, 4/84, 4X, 10, and ROBIE (KAYPRO computers with graphics capability):

Reverse video start	ESCape,B,0
Reverse video stop	ESCape,C,0
Half intensity start	ESCape,B,1
Half intensity stop	ESCape,C,1
Blinking start	ESCape,B,2
Blinking stop	ESCape,C,2
Underline start	ESCape,B,3
Underline stop	ESCape,C,3
Cursor on	ESCape,B,4
Cursor off	ESCape,C,4
Video mode on	ESCape,B,5
Video mode off	ESCape,C,5
Remember current cursor position	ESCape,B,6
Return to last remembered cursor position	ESCape,C,6
Status line preservation on	ESCape,B,7
Status line preservation off	ESCape,C,7
Set pixel	ESCape,*,V1,H1
Clear pixel	ESCape, ,V1,H1
Set line	ESCape,L,V1,H1,V2,H2
Delete line	ESCape,D,V1,H1,V2,H2

## 16.2 KEYBOARD CODES AND FUNCTIONS

Control key functions in CP/M:

DEL	Delete and echo the last character typed at the console (same as rubout).
CTRL-C	CP/M system reboot (warm start).
CTRL-E	Physical, not logical, end of line. Carriage is returned, but line is not sent until RETURN key is pressed.
CTRL-G	Bell; sounds an audible bell (from keyboard).
CTRL-H	Backspace; move cursor left one character position.
CTRL-I	Horizontal tab, moves cursor to the next defined tab stop. (CP/M assumes tab stops at every 8th position).
CTRL-J	Linefeed: move cursor down one line.
CTRL-M	Carriage return; return cursor to left margin.
CTRL-R	Retype current command line. Types a "clean line" following character deletion with rubouts.
CTRL-U	Delete the entire line typed at the console.
CTRL-X	Same as CTRL-U.

SEE ALSO: ASCII character chart, Section 17.1.

### 16.3 CONNECTOR PIN-OUTS

This section contains drawings of the pin assignments on various output ports on Kaypro computers, intended as an aid in building printer cables and in troubleshooting problems with peripherals.

CONNECTOR PIN-OUTS, KAYPRO 2/83 AND KAYPRO 4/83

PARALLEL PRINTER PORT: J2

STROBE	1	19	
(LSB) DATA 0	2	20	
DATA 1	3	21	
DATA 2	4	22	
DATA 3	5	23	
DATA 4	6	24	
DATA 5	7	25	GROUND
DATA 6	8	26	
(MSB) DATA 7	9	27	
N/C	10	28	
BUSY (IN)	11	29	
	12	30	
	13	31	
N/C	14	32	N/C
	15	33	GROUND
	16	34	
GROUND	17	35	N/C
N/C	18	36	

Top of connector

Bottom of connector

Note that the BUSY line is read by the KAYPRO as active when it's disconnected (no cable). The computer will hang if you attempt to print to an unconnected parallel printer.

**KAYPRO 2/83 AND KAYPRO 4/83 KEYBOARD CONNECTOR (J3)**

TxD	4	2	RxD
GND	3	1	+5V

**KAYPRO 2/83 AND KAYPRO 4/83 SERIAL PORT (RS232C — J4)**

GROUND	1	
		14
TxD	2	
		15
RxD	3	
		16
	4	
		17
CTS	5	
		18
	6	
		19
GROUND	7	
		20
	8	DTR
		21
	9	
		22
	10	
		23
N/C	11	N/C
		24
	12	
		25
	13	

Top of connector Bottom of connector

### KAYPRO 10 MODEM PORT (J3)

GROUND	1		
		14	
TxD	2		
		15	
RxD	3		
		16	
RTS	4		
		17	
CTS	5		
		18	
+5V	6		
		19	
GROUND	7		
		20	DTR
DCD	8		
		21	
	9		
		22	
	10		
		23	
	11		
		24	
	12		
		25	
	13		

Top of connector

Bottom of connector

### KAYPRO 10 KEYBOARD CONNECTOR (J5)

The pin-out for this connector is the same as J3 on the KAYPRO 2/83 and KAYPRO 4/83. See page 16—6.

### KAYPRO 10 PARALLEL PRINTER CONNECTOR (J6)

The pin-out for this connector is the same as J2 on the KAYPRO 2/83 and KAYPRO 4/83. See page 16—5.

**KAYPRO 10 SERIAL PRINTER PORT (RS232C — J4)**

GROUND	1	14	
RxD	2	15	
TxD	3	16	
	4	17	
	5	18	
	6	19	
GROUND	7	20	CTS
	8	21	
	9	22	
	10	23	N/C
	11	24	
	12	25	
	13		

Top of connector

Bottom of connector



**KAYPRO 2/84, 2X, 4/84, 4X AND ROBIE KEYBOARD CONNECTOR (J2)**

The pin-out for this connector is the same as J3 on the KAYPRO 2/83 and KAYPRO 4/83. See page 16--6.

**KAYPRO 2/84, 2X, 4/84, 4X AND ROBIE SERIAL DATA CHANNEL (J4)**

The pin-out for this connector is the same as J4 on the KAYPRO 2/83 and KAYPRO 4/83. See page 16--6.

**KAYPRO 2/84, 2X, 4/84, 4X AND ROBIE SERIAL PRINTER CONNECTOR (J3)**

GROUND	1	14	
RxD	2	15	
TxD	3	16	
	4	17	
N/C	5	18	
	6	19	
GROUND	7	20	CTS
	8	21	
	9	22	
	10	23	N/C
N/C	11	24	
	12	25	
	13		

**KAYPRO 2/84, 2X, 4/84, 4X AND ROBIE PARALLEL PRINTER CONNECTOR (J5)**

PSTROB	1	19	
D0	2	20	
D1	3	21	
D2	4	22	
D3	5	23	
D4	6	24	
D5	7	25	
D6	8	26	GROUND
D7	9	27	
	10	28	
	11	29	
	12	30	
	13	31	
	14	32	
	15	33	
GROUND	16	34	GROUND
	17	35	
SPARE	18	36	

**KAYPRO 4/84, 4X AND ROBIE MODEM CONNECTOR (J6)**

Note that this is NOT connected on the 2/84 and 2X.

N/C	1		
		2	N/C
TIP (Green)	3		
		4	RING (Red)
N/C	5		
		6	N/C

## 16.4 I/O PORT ADDRESSES

The port addresses below apply to KAYPRO 2/83 and 4/83 computers.

Port #	Use and/or Assignment
00	Baud Rate (write only) - Writing a number between 0 and F hex (see baud rate table) to this port sets the RS-232C baud rate.
04	RS-232C Serial Data (R/W) - Data register of the Z-80 SIO. Refer to Zilog/Mostek Microcomputer Data books for further information.
05	Keyboard Data (R/W) - Eight-bit data from detachable keyboard.
06	RS-232C Status (R/W) - Control/status port for the Z-80 SIO. Refer to Zilog/Mostek Microcomputer Data books for further information.
08	Printer Port (write only) - Eight-bit data to parallel printer connector.
1C	System Port (R/W) - This port is used for system control. The various bits are used for memory bank selection, disk drive control, and printer handshaking.

The serial output is an 8-bit word with one start, one stop, and no parity.

### Examples:

- \* Received character available is obtained by testing bit 0 of the status port. Character is available if this bit is high (a 1 rather than 0).
- \* Transmit Buffer Empty is obtained by testing bit 2 of the status port. Buffer is empty when bit 2 is high (1).

Manuals on the Z-80 CPU, Z-80 PIO, Z-80 SIO are available from the ZILOG sales office nearest to you. Western Digital can sell you a copy of the manual for the Floppy Disk Controller. Refer to Reference Section for vendors' mailing addresses and phone numbers.

When ordering manuals for any of the chips mentioned above, remove the hood from the computer and write down the full model number that is on the top surface of the chip. This is the best way to be certain of getting the proper manual from either of the manufacturers listed above.

The following port address information applies to KAYPRO 10, KAYPRO 2/84, KAYPRO 2X, KAYPRO 4/84, KAYPRO 4X, and KAYPRO ROBIE.

### I/O PORT ADDRESSES

<u>Use</u>	<u>Port# (hex)</u>	<u>Device</u>	<u>Function</u>
<b>Keyboard:</b>			
	05	ZSIO 1 Chan. B	Keyboard data(R/W). Eight-bit data from keyboard.
	07	ZSIO 1 Chan. B	Keyboard control/status I/O.
<b>Video:</b>			
	1C	6545/6845 EA	CRT controller status/control I/O.
	1D	6545/6845 EA	CRT controller data I/O.
<hr/> <hr/>			
<b>Parallel Printer: (output only)</b>			
	18 - 1B	74 373	Parallel printer port (write only).
<hr/> <hr/>			
<b>Serial Printer I/O:</b>			
	08 - 0B	WD 1943 COM 8116	Baud rate for serial printer port.
	0C	ZSIO 2 Chan. A	Serial printer data I/O (RS-232C).
	0E	ZSIO 2 Chan. A	Serial printer control/status I/O.
<hr/> <hr/>			
<b>Serial Data I/O:</b>			
	00 - 03	WD 1943 COM 8116	Baud rate for serial data port (write only).
	04	ZSIO 1 Chan. A	Serial data port (RS-232C). Data I/O.
	06	ZSIO 1 Chan. A	Serial data port (RS-232C). Status/control I/O.

<u>Use</u>	<u>Port#</u> <u>(hex)</u>	<u>Device</u>	<u>Function</u>
Real-time clock:	20	(NS-MM58167A) PIO Chan. A	Real-time clock register select and interrupt status.
			Bit functions:
			0 lsb register select (output).
			1 "
			2 "
			3 "
			4 msb register select (output).
			5 not used
			6 rtc interrupt output (input).
			7 rtc not standby interrupt output (input).
	22	PIO Chan. A	Real-time clock PIO control port.
	24	MM 58167A	Real-time clock data I/O.

<u>Use</u>	<u>Port# (hex)</u>	<u>Device</u>	<u>Function</u>
System:	14 - 17	74 373	System output port.  Bit functions.  0 0=Select floppy A (C on K10). 1 0=Select floppy B (Hard disk on K10). 2 0=Select side 2. 3 PSTROB 4 0=Floppy motor on (48 tpi drives). 1=Select high speed (High density drive). * see note 5 0=Select double-density. 6 0=Select normal character set. 7 0=Select 64K RAM. 1=Select ROM (RAM 8000-FFFF).
		74 244	System input port.  Bit functions.  0 0=floppy A selected (C on K10). 1 0=floppy B selected (Hard disk on K10). 2 0=Side 2 selected. 3 PSTROB. 4 0=motor is on (48 tpi floppy). 5 0=Double-density is selected. 6 0=Parallel printer is busy. 7 0=64K RAM is selected. 1=ROM (RAM 8000-FFFF) selected.

\* Note on high-density drives:

A 1 in bit position 4 will select high speed on the high-density diskette drive. To reset the drive to low speed it is necessary to change this bit to a 0 AND open the drive door, then close it.



<u>Use</u>	<u>Port# (hex)</u>	<u>Device</u>	<u>Function</u>
	80	WD 1002	Hard disk controller card data I/O port.
	81		Error Register (input). Write Precomp. (output).
	82		Sector count register I/O.
	83		Sector number register I/O.
	84		Cylinder low register I/O.
	85		Cylinder high register I/O.
	86		Size/drive/head register I/O.
	87		Status register for input. Command register for output.



## 17.0 REFERENCE SECTION

### 17.1 ASCII CHART

Dec	Hex	Char	Dec	Hex	Char	Dec	Hex	Char	Dec	Hex	Char
0	00	NUL or ^@	32	20	Space	64	40	@	96	60	`
1	01	SOH or ^A	33	21	!	65	41	A	97	61	a
2	02	STX or ^B	34	22	"	66	42	B	98	62	b
3	03	ETX or ^C	35	23	#	67	43	C	99	63	c
4	04	EOT or ^D	36	24	\$	68	44	D	100	64	d
5	05	ENQ or ^E	37	25	%	69	45	E	101	65	e
6	06	ACK or ^F	38	26	&	70	46	F	102	66	f
7	07	BEL or ^G	39	27	'	71	47	G	103	67	g
8	08	BS or ^H	40	28	(	72	48	H	104	68	h
9	09	HT or ^I	41	29	)	73	49	I	105	69	i
10	0A	LF or ^J	42	2A	*	74	4A	J	106	6A	j
11	0B	VT or ^K	43	2B	+	75	4B	K	107	6B	k
12	0C	FF or ^L	44	2C	,	76	4C	L	108	6C	l
13	0D	CR or ^M	45	2D	-	77	4D	M	109	6D	m
14	0E	SO or ^N	46	2E	.	78	4E	N	110	6E	n
15	0F	SI or ^O	47	2F	/	79	4F	O	111	6F	o
16	10	DLE or ^P	48	30	0	80	50	P	112	70	p
17	11	DC1 or ^Q	49	31	1	81	51	Q	113	71	q
18	12	DC2 or ^R	50	32	2	82	52	R	114	72	r
19	13	DC3 or ^S	51	33	3	83	53	S	115	73	s
20	14	DC4 or ^T	52	34	4	84	54	T	116	74	t
21	15	NAK or ^U	53	35	5	85	55	U	117	75	u
22	16	SYN or ^V	54	36	6	86	56	V	118	76	v
23	17	ETB or ^W	55	37	7	87	57	W	119	77	w
24	18	CAN or ^X	56	38	8	88	58	X	120	78	x
25	19	EM or ^Y	57	39	9	89	59	Y	121	79	y
26	1A	SUB or ^Z	58	3A	:	90	5A	Z	122	7A	z
27	1B	ESC or ^[	59	3B	;	91	5B	[	123	7B	{
28	1C	FS or ^\	60	3C	<	92	5C	\	124	7C	
29	1D	GS or ^]	61	3D	=	93	5D	]	125	7D	}
30	1E	RS or ^^	62	3E	>	94	5E	^	126	7E	~
31	1F	US or ^_	63	3F	?	95	5F	_	127	7F	DEL

17.3 MEMORY MAPS

MEMORY MAP OF KAYPRO 2 AND KAYPRO 4

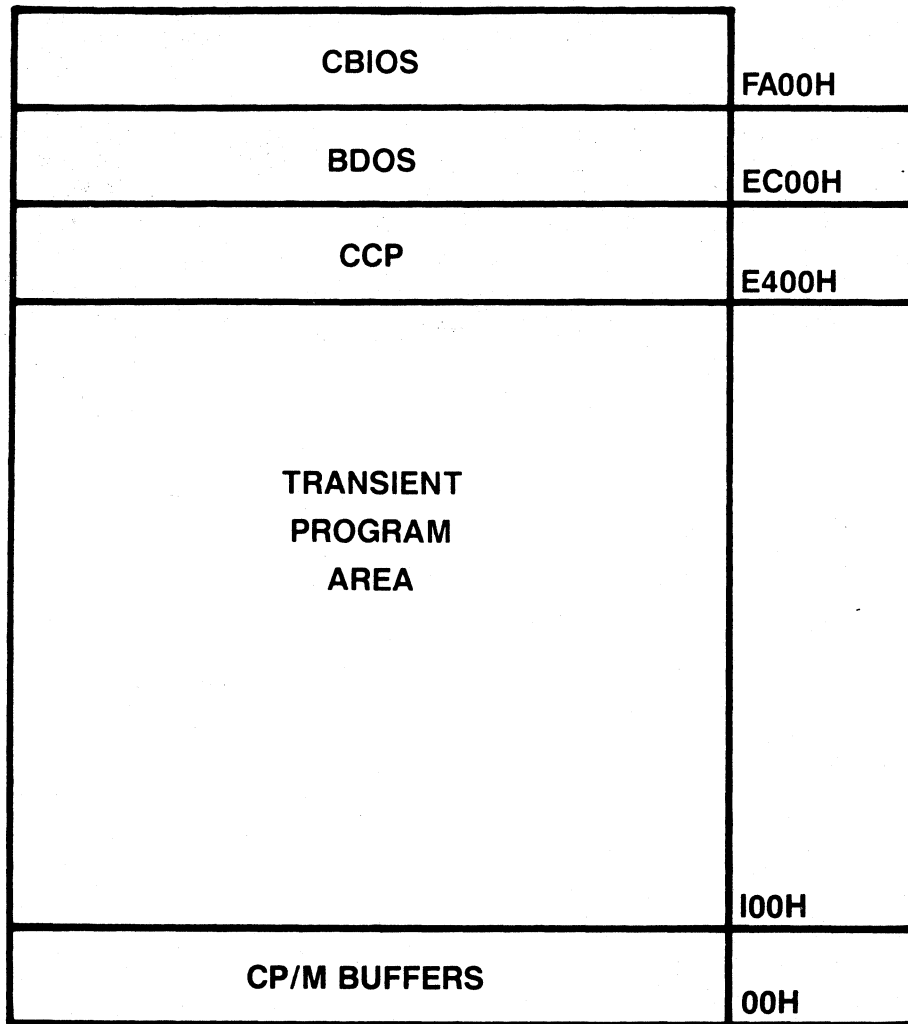

# MEMORY MAP OF KAYPRO 10

CBIOS	EA00H
BDOS	DC00H
CCP	D400H
TRANSIENT PROGRAM AREA	100H
CP/M BUFFERS	00H

# MEMORY MAP OF KAYPRO 2/84 AND 4/84

CBIOS	F600H
BDOS	E800H
CCP	E000H
TRANSIENT PROGRAM AREA	100H
CP/M BUFFERS	00H

# MEMORY MAP OF KAYPRO ROBIE

CBIOS	F200H
BDOS	E400H
CCP	DC00H
TRANSIENT PROGRAM AREA	100H
CP/M BUFFERS	00H

## 17.4 VENDOR ADDRESSES

Kaypro Corporation does not provide repair or reference manuals for other companies' products which are used in Kaypro computers. The list below does not presume to be complete, but is included for dealer convenience in ordering manuals directly from the manufacturer.

### Drives

Drivetec  
2140 Bering Drive  
San Jose, Ca. 95131  
(408) 946-2222

Epson  
17752 Skypark #255  
Irvine, Ca 92714  
(714) 250-0111

HI-TEC  
10150 Sorrento Valley Rd.  
San Diego, Ca. 92121  
(619) 452-5500

Microscience  
575 E. Middlefield Road  
Mountain View, Ca. 94043  
(415) 961-2212

Seagate  
920 Disc Drive  
Scotts Valley, Ca. 95066  
(408) 438-6550

Shugart  
475 Oakmead Parkway  
Sunnyvale, Ca. 94086  
(408) 733-0100

Tandon  
20320 Prairie St.  
Chatsworth, Ca. 91311  
(213) 993-6644

TEC  
1000 E. Walnut St.  
Pasadena, Ca. 91106  
(213) 681-5631

Toshiba  
9030 Carroll Canyon #7  
San Diego, Ca. 92121  
(619) 578-9171

### Integrated Circuits

Mostek  
18004 Skypark Circle  
Suite 140  
Irvine, Ca. 92714  
(714) 250-0455

National Semiconductor  
2900 Semiconductor Drive  
Santa Clara, Ca. 95051  
(408) 737-5000

Texas Instruments  
17620 Fitch  
Irvine, Ca. 92714  
(714) 545-5210

Western Digital  
3128 Red Hill Ave.  
Costa Mesa, Ca. 92626

Zilog  
18023 Skypark Circle  
Suite J  
Irvine, Ca. 92714  
(714) 549-2891

CRT Assemblies

Audiotronics  
7420 Belair Ave.  
N. Hollywood, Ca. 91605  
(213) 765-2645

Dotronix  
160 1st Street S. E.  
New Brighton, MN. 55112  
(612) 633-1742

Elston  
35 Lehigh Street  
Geneva, N.Y. 14456  
(315) 781-1350

Toshiba  
9030 Carroll Canyon #7  
San Diego, Ca. 92121  
(619) 578-9171

Keyboards

Keytronics  
7032 Owensmouth  
Canoga Park, Ca. 91303  
(714) 832-1685

Maxi-Switch  
9697 E. River Road  
Minneapolis, MN. 55433  
(612) 755-7660

SMK  
4617 Ruffner Street #206  
San Diego, Ca. 92111  
(619) 560-8330

Power Supplies

Astec  
1101 Space Park  
Santa Clara, Ca. 95050  
(408) 727-3350

Boschert  
384 Santa Trinita Ave.  
Sunnyvale, Ca. 94086  
(408) 732-2240

Cal D.C.  
2150 Anehor Court  
Newbury Park, Ca. 91320  
(805) 499-3621

Disk Controller Board

Western Digital  
2445 McCabe Way  
Irvine, Ca. 92714  
(714) 863-0102

KBD ~~2160150~~ A65-02706 .001  
PCBD ~~630184-02~~ -201

KYBD 2160150  
PCBD 630184-02

3-39011-02Y  
TW-1794V-0

## 18.0 SUGGESTED REFERENCES

**KAYPRO II Theory of Operation**, by Dana Cotant-Micro Cornucopia,  
P.O. Box 223 - Bend, OR. 97709

**Modern Dictionary of Electronics**, by Rudolf F. Graf, Radio Shack Catalog  
Number 62-2310

Some **colored markers or pencils** with which to mark the chip layout diagrams in this manual according to function (video, disk control, etc.) will be useful. Such "maps" can be time-saving devices. (Because of printing costs and problems, Kaypro is unable to supply colored "maps" in the Technical Manual.)

The **CP/M Manual** included with each KAYPRO. You can devise excellent and effective tests for the machines through imaginative use of CP/M programs like PIP, SUBMIT, XSUB. To this end, books about CP/M (with an emphasis on programming; not for the beginner) can be helpful.

A good book containing information on the **Z80 microcomputer** and its family (SIO, PIO). Timing diagrams (or scope signals) in these books can help troubleshoot mainboards.

Any **component repair manuals** you feel necessary. See Section 17.4 for vendor addresses.



## INDEX

220V configuration, 8--2  
align.mac, 7--5  
aligning CRT yoke, 7--2  
ASCII chart, 17--1  
brightness, 7--2  
chassis hood, 5--1  
CRT adjustments, 7--1  
CRT assembly removal, 7--8  
CRT descriptions, 7--1  
disk drive cleaning, 9--1  
diskette drive configuration, 9--5  
diskette drive identification, 9--2  
diskette drives, 9--1  
Drivetec, 9--9  
focus, 7--2  
fuse, 8--2  
hard disk drive, 10--1  
hard drive configuration, 10--3  
hard drive controller board, 11--1  
hard drive removal, 10--4  
high-density (Drivetec) drives, 9--9  
horizontal centering, 7--1  
horizontal hold, 7--2  
horizontal width, 7--1  
I/O port addresses, 16--10  
interface board KAYPRO 10, 12--1  
internal modem, 16--14  
KAYPRO 10 block diagram, 6--18  
KAYPRO 10 specifications, 3--1  
KAYPRO 2 and 4 block diagram, 6--6  
KAYPRO 2 specifications, 3--1  
KAYPRO 2/84 and 2X specifications, 3--2  
KAYPRO 4 specifications, 3--3  
KAYPRO 4/84 specifications, 3--4  
KAYPRO 4X specifications, 3--5  
KAYPRO ROBIE specifications, 3--7  
keyboard, 13--1  
keyboard codes and functions, 16--3  
keyboard connector, 16--6  
mainboard removal, 6--51  
mainboards, 6--1  
memory maps, 17--3  
modem port KAYPRO 10, 16--7  
parallel printer port, 16--5  
power supplies, 8--1  
power supply removal, 8--5  
real-time clock, 16--12  
ROBIE removal/installation, 14--1  
serial port KAYPRO 2 and 4, 16--6  
serial printer port KAYPRO 10, 16--7.1  
touch-up information, 5--2  
troubleshooting, 15--1  
vendor addresses, 17--6  
vertical size and linearity, 7--1  
video alignment, 7--3  
video command protocol, 16--1

PUBLICATION COMMENT SHEET

Please use this comment sheet to assist with identification of errors or needed improvements in this manual.

Date \_\_\_\_\_

Name \_\_\_\_\_

Job Title \_\_\_\_\_

Address \_\_\_\_\_

Page

Comment

_____	_____
_____	_____
_____	_____
_____	_____
_____	_____
_____	_____
_____	_____
_____	_____

Please mail this form to the following address.

Publications Department  
Kaypro Corporation  
P.O. Box N  
Del Mar, Ca. 92014