

**Operating
The HP 250**

HP 250

Operating the HP250

Manual Part No. 45260-90002 E1281

Hewlett-Packard Company

19140 Homestead Road, Cupertino, California, U.S.A. 95014

Printing History

New editions of this manual will incorporate all material updated since the previous edition. Update packages may be issued between editions and contain replacement and additional pages to be merged into the manual by the user. Each updated page will be indicated by a revised date at the bottom of the page. A vertical bar in the margin indicates the changes on each page. Note that pages which are rearranged due to changes on a previous page are not considered revised.

The manual printing date and part number indicate its current edition. The printing date changes when a new edition is printed. (Minor corrections and updates which are incorporated at reprint do not cause the date to change.) The manual part number changes when extensive technical changes are incorporated.

November 1981 ... FIRST EDITION

January 1982...revised pages for ii through
vii, 2-1, 2-3, 2-6, 5-1,5-5,
5-13, 6-2, C-1, C-2

NOTICE

The information contained in this document is subject to change without notice.

HEWLETT-PACKARD MAKES NO WARRANTY OF ANY KIND WITH REGARD TO THIS MATERIAL, INCLUDING, BUT NOT LIMITED TO, THE IMPLIED WARRANTIES OF MERCHANTABILITY AND FITNESS FOR A PARTICULAR PURPOSE.

Hewlett-Packard shall not be liable for errors contained herein or for incidental or consequential damages in connection with the furnishing, performance, or use of this material.

Hewlett-Packard assumes no responsibility for the use or reliability of its software on equipment that is not furnished by Hewlett-Packard.

This document contains proprietary information which is protected by copyright. All rights are reserved. No part of this document may be photocopied, reproduced, or translated to another program language without the prior written consent of Hewlett-Packard Company.

Table of Contents

Chapter 1: System Overview

Chapter 2: System Start-Up

Loading from an Integrated Storage Unit.....	2-1
Loading from the Cartridge Tape Drive.....	2-1
Loading from the HP 7908, 7911, or 7912 Disc.....	2-3
Loading from a Flexible Disc Drive.....	2-4
Loading from a HP 7906 Disc Drive.....	2-6
Using a 5 Mb. Disc Drive.....	2-6
Shutting Down the System.....	2-8

Chapter 3: Workstations

SECTION A: The HP 2622D Personal Workstation

Display.....	3-2
Thermal Printer (Optional).....	3-3
Keyboard.....	3-3
Typewriter Block.....	3-3
Data Entry Pad.....	3-5
Display Editing Keys	3-6
Execute Key.....	3-7
Halt Key.....	3-7
Remote Keys.....	3-8
Softkeys.....	3-8
User-Defined Keys.....	3-9
System Defined Keys.....	3-10
Shift Function Keys.....	3-10
Setting 2622D Configuration.....	3-10
Printing a Screen Image to Thermal Printer.....	3-11
The Status Display.....	3-12
Softkey Set Status	3-12
Modem Status.....	3-12
Insert Character Status	3-12
Displaying All Softkey Labels.....	3-12
Control Function Keys.....	3-14
Line Drawing Character Set.....	3-14
Display Character Set.....	3-15
Display Enhancement Set.....	3-15

SECTION B: The HP 250/35 Integral Workstation

Display.....	3-16
Keyboard.....	3-17
Typewriter Block.....	3-17

Table of Contents

Data Entry Pad.....	3-19
Display Editing Keys.....	3-19
Execute Key.....	3-21
Halt Key.....	3-21
Softkeys.....	3-22
User Defined Softkeys.....	3-22
Control Function Keys.....	3-23
Line Drawing Character Set.....	3-23
Display Character Set.....	3-24
Display Enhancement Set.....	3-24

SECTION C: The HP 2649D Workstation

Display.....	3-25
Keyboard.....	3-26
Typewriter Block.....	3-26
Data Entry Pad.....	3-28
Display Editing Keys.....	3-28
Execute Key.....	3-30
Halt Key.....	3-30
Remote Keys.....	3-31
Softkeys.....	3-32
User Defined Softkeys.....	3-32
Control Function Keys.....	3-33
Line Drawing Character Set.....	3-33
Display Character Set.....	3-34
Display Enhancement Set.....	3-34
Testing the 2649D Workstation.....	3-35
Extended Tests.....	3-35

Chapter 4: Keyboard Operations

Solving Arithmetic Problems.....	4-1
Correcting Typographical Errors.....	4-4
Understanding Error Messages.....	4-5

Chapter 5: Storage Devices and Media

HP Integrated Storage Product.....	5-2
HP 7908, 7911, and 7912 Disc Drives.....	5-2
Cartridge Tape Drive.....	5-3
Tape Cartridges.....	5-3
Handling Tape Cartridges.....	5-4
Inserting a Tape Cartridge.....	5-4
Using the Tape Drive.....	5-5
Removing a Tape Cartridge.....	5-5
Flexible Disc Drive.....	5-7
Handling Flexible Discs.....	5-7
Inserting a Flexible Disc.....	5-8
Removing a Flexible Disc.....	5-8

The HP 7906 Disc Drive.....5-9
 Removable Disc Cartridges.....5-9
 Storing Disc Cartridges.....5-9
 Using the HP 7906.....5-10
 Starting up the HP 7906.....5-11
 Changing a Disc Cartridge.....5-12
 Shutdown Procedure.....5-12
 5 Mb. Disc Drive.....5-13

Chapter 6: Printers

HP 2631 Dot Matrix Printers.....6-2
 Loading Paper.....6-2
 Replacing Ribbon Cartridges.....6-4
 Removal.....6-4
 Installation.....6-4
 Cleaning the Print Head.....6-4
 HP 2608A Printer6-5
 Operator Safety.....6-5
 Loading and Adjusting Paper.....6-5
 Replacing Ribbon Cartridges.....6-8
 Removal.....6-9
 Installation.....6-9
 HP 2601 Letter Quality Printer.....6-10
 Loading Paper or Forms.....6-10
 Paper Thickness/Print Intensity Adjustment.....6-10
 Installing a Print Wheel.....6-11
 Replacing a Ribbon Cartridge.....6-12
 Cleaning Print Wheels.....6-13
 Changing Ribbons During Operation.....6-13
 Cleaning the Print Hammer.....6-13
 HP 2622D Thermal Printer.....6-14
 Loading Thermal Printer Paper.....6-14

Chapter 7: Graphics Devices

Graphics Plotters.....7-1
 Turning on AC Power.....7-3
 Loading Pens and Paper.....7-4
 Disabling the Plotter.....7-5
 Changing Pens.....7-5
 Changing Sheet Paper.....7-7
 Changing Roll Paper.....7-8
 Loading Overhead Transparency Materials.....7-9
 Transparency Film Pens.....7-9
 Transparency Film.....7-10
 Limitation of some early HP 7225A Models.....7-10
 Routine Maintenance.....7-11
 Electrostatic Paper Hold-Down Surface Cleaning.....7-11
 Air Filter Cleaning.....7-12

Table of Contents

Chapter 8: System Commands

Accessing Files on Storage Devices.....	8-1
Assigning Names to Storage Media (PRINT LABEL).....	8-2
Physical Addresses.....	8-2
Changing the Default Mass Storage Device (MSI).....	8-2
Executing Programs (RUN).....	8-3
Erasing the Contents of Memory (SCRATCH).....	8-4
File Operations.....	8-4
Storing Programs (STORE).....	8-4
Transferring Program Files into Memory (LOAD).....	8-5
Storing Data Files (SAVE).....	8-5
Transferring Data Files into Memory (GET).....	8-5
Copying a File (COPY).....	8-6
Copying to the Same Mass Storage Devices.....	8-6
Copying to a Different Mass Storage Device.....	8-6
Cataloging Files (CATALOG).....	8-7
Selective Catalogs.....	8-8
Deleting Files from a Mass Storage Device (PURGE).....	8-9
Output Commands.....	8-9
Peripheral Addresses.....	8-10
Outputting Listings and Catalogs (SYSTEM PRINTER IS).....	8-10
Printing all Displayed Information (PRINT ALL IS).....	8-10
Setting a Printer to Top of Form.....	8-11

Chapter 9: Maintenance

General Cleaning.....	9-1
-----------------------	-----

Chapter 10: In Case of Difficulty

Start-Up Errors.....	10-2
Self-Test Failure.....	10-2
System Loading	10-2
Loader Errors.....	10-3
Configuration Messages.....	10-3
Remote Workstation Failure.....	10-3
Processing Errors.....	10-4
Hardware Failures.....	10-4
Software Errors.....	10-4
Operator Errors.....	10-5
System Errors.....	10-5
System Tests.....	10-7
Display Tests.....	10-8
Printer Test.....	10-9
Media Test.....	10-10
IBM Media Test.....	10-13
Keyboard Test.....	10-14
Plotter Test.....	10-15

Appendix A: Glossary

Appendix B: Keyboards

Appendix C: Volume Specifiers

Appendix D: Using Softkeys as Typing Aids

Appendix E: Error Messages

CHAPTER 1

System Overview

Welcome to the HP 250 Office Computer System. The HP 250 is an easy-to-operate business computer that allows you to enter, process, and access information, and output reports in the form of hard-copy print or on a display screen.

The HP 250 Office Computer can be used in a variety of environments, from small single-user configurations to larger systems capable of processing several tasks. From any starting configuration, the system can be expanded to meet growing business needs.

To allow for this flexibility, the HP 250 has been designed as a series of components. Each system consists of four major components: the central processing unit, the workstation, the mass storage device(s), and the printer(s). The central processing unit is the "brain" of your system. You talk to it via the keyboard of your workstation, which resembles an office typewriter. The display, a television-like screen, is useful for viewing input data and for filling forms. The mass storage devices are used for storing and accessing information and programs. The actual storage medium may be a disc or a tape cartridge. The printer is used to produce hard-copy reports which contain the information required in the day-to-day operation of your business.

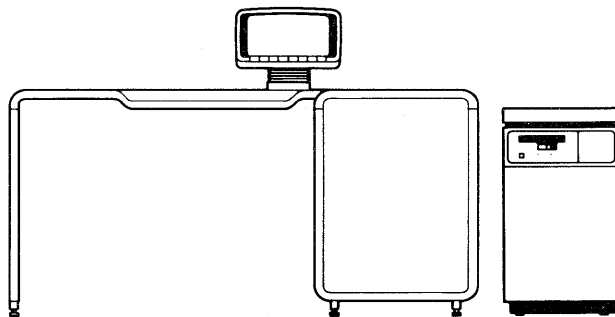

HP 250/35

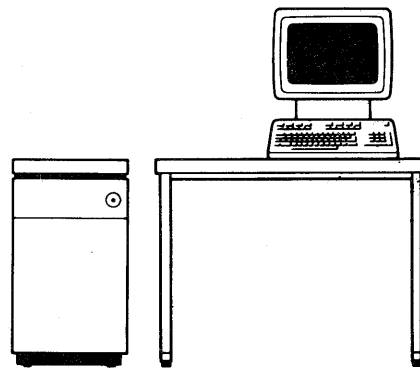

HP 250/30

System Overview

It is important that you are able to recognize all of the components of your system and understand their functions. This guide describes all possible components and configurations of the HP 250. Do not be alarmed if you see a picture of a component in this book which you cannot identify as part of your system.

The following are drawings of all the possible components of your system. Learn the names of those components which make up your particular configuration. Then, if you need information about a specific component, turn to either the Table of Contents or the Index of this manual.

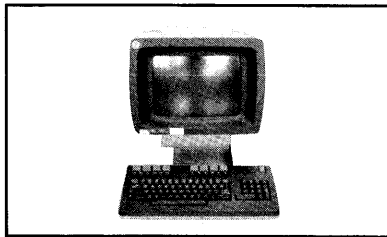

HP 2622D Personal Workstation

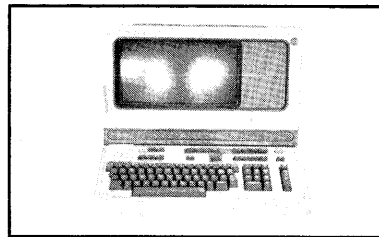

HP 2649D Remote Workstation

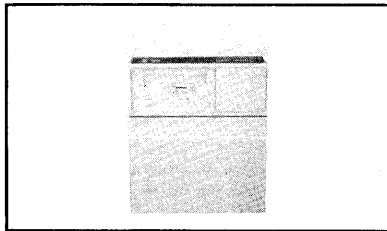

HP 7908P Integrated Storage Product

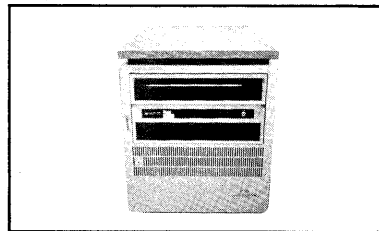

HP 7906 Disc Drive

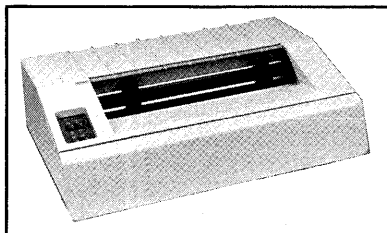

HP 2631A Line Printer

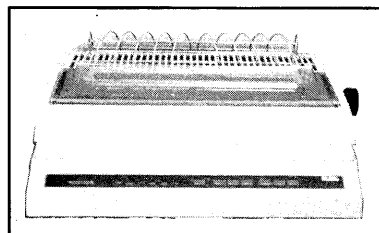

HP 2601 Line Printer

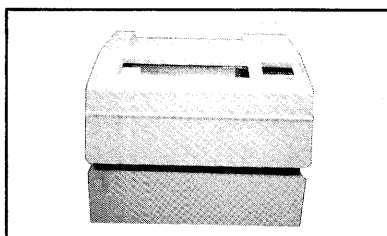

HP 2608 Line Printer

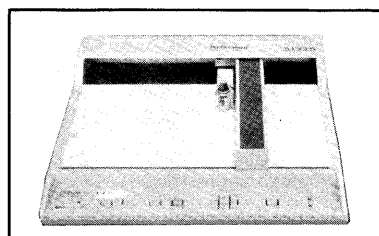

HP Plotter

This manual is organized to be read sequentially. Chapters 2 through 4 contain the background information necessary to turn the system on, understand your workstation keyboard and its features, and interact with the computer.

Chapters 5, 6, and 7 get you acquainted with the different types of storage devices, storage media, printers, and graphics devices that may be part of your HP 250; it is important that you recognize the relationships between the components of the system.

Once you understand the different components of your HP 250 system, proceed to Chapter 8. There you will find several HP 250 BASIC Commands that will be useful in the day-to-day operation of your system.

Chapter 9 and 10 describe typical maintenance procedures and what to do if you encounter a problem with the system.

The appendices provide reference material that you may find occasionally helpful (such as error messages). Words printed in bold type throughout the manual appear in the Glossary (Appendix A).

As stated before, you may find that some of the material in this manual is not applicable to your particular configuration or your daily task. We do recommend, however, that you hold onto this information for future reference. You may someday add a printer, workstation, or mass storage device to your system. Additionally, your daily responsibilities may not require some of the material presented here, but you should take the time to read it anyway; that way you will know where to find the answer to a question that may come up.

Even though various HP 250 configurations look physically different, you will have no problem operating your system once you recognize and understand the different components.

Finally, you should remember that this guide is not a programming manual. The information presented here is what you need to operate your HP 250 system. If you need programming information, you should consult the appropriate manual, which is included in the HP 250 Programming Manual Kit.

CHAPTER 2

System Start-up

After a Hewlett-Packard Customer Engineer has installed your HP 250 system, it is ready to operate.

Starting up (or loading) your system can be compared to starting an automobile. Your car must have fuel in it before you can successfully start it by turning the ignition key. In the same way, your HP 250 must have a version of the system software available. This system software may be stored on a fixed disc or on a removable medium such as a tape cartridge or flexible disc. It is the "fuel" required to start your system.

Once you have successfully started your system up, turn it off only when you are sure that no other task will be affected. For example, you may have completed your work and are now ready to leave the office for the day. If you shut any part of the system down (including a disc drive), you can affect work being done by another person.

Loading From an Integrated Storage Unit

An Integrated Storage Unit consists of two different storage devices - a cartridge tape drive and a disc (HP 7908, 7911, or 7912). When your system first arrives, you can start it from a tape cartridge only. Once you have successfully started the system using a tape, you can then run the ROUTIL Utility Program to copy all files on a tape over to the disc; doing this allows you to start your system from either a tape cartridge or the disc. See the HP 250 System Utilities Manual (45260-90061) for information on the ROUTIL Utility Program.

Loading from the Cartridge Tape Drive

The following is the procedure for loading your HP 250 system from the cartridge tape drive.

1. Turn the Integrated Storage Unit power switch to the ON position.

System Start-up

2. Insert the tape cartridge labeled SYSTEM into the drive, label side up.

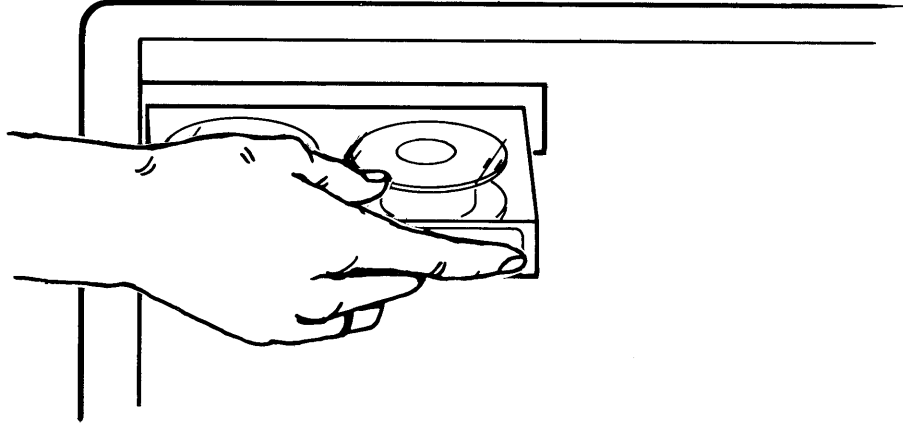

3. Insert the key into the processing unit and turn it clockwise to position 1 (see drawing below). The drive door is locked automatically during loading. If the BUSY light (indicating that the drive is in use) never comes on, it may mean that the tape cartridge was inserted improperly. Push the lever, remove the tape, re-insert it and then turn the key again.

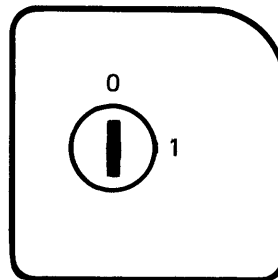

4. A system self-test is performed automatically when the power is turned on. As the test is performed, a listing of system components is shown on the display of the principal workstation (see glossary in back). If any component fails, the system is not operable. If this occurs, consult the chapter titled "In Case of Difficulty".

5. If no problem occurs, a message in the form:

SYSTEM LOADING

followed by:

LOADING DROMS

is shown. The message remains on the screen for about 30 seconds. When the loading process is complete, a blinking underscore, known as the cursor, is displayed.

If the message:

The "SYSTEM" file was not found

appears on the screen while loading the tape either you did not insert the cartridge properly or the tape you used did not have the system software on it. You should turn the key to the off position (0), ensure that the tape cartridge in the drive is labeled SYSTEM, and then repeat the loading procedure.

When the system has been properly loaded, you may remove the tape cartridge labeled SYSTEM from the drive. Press the UNLOAD key on the drive. The BUSY light will flash. When the tape cartridge is ready to be removed, a buzzer sounds. Pull the lever gently to the right and remove the cartridge from the drive.

If the result of the self-test is an error message or the system failed to power on, consult the section titled "In Case of Difficulty".

Loading from the HP 7908,7911, or 7912 Disc

After the operating system has been copied to an HP 7908, 7911, or 7912 disc, you can start your HP 250 directly from the disc.

1. Turn the power switch of the Integrated Storage Product to the ON (1) position. Ensure that no storage medium labeled SYSTEM is in any other drive.
2. Insert the key of the HP 250 into the lock and turn it clockwise to position 1.
3. A system self-test is automatically performed when you turn the power on. As the test is performed, a list of system components is displayed. If any component fails, the system is not operable; consult the chapter "In Case of Difficulty" if this occurs.

System Start-up

If no problem occurs, a message in the form:

SYSTEM LOADING

followed by:

LOADING DROMS

is shown. The message remains on the screen for about ten seconds. A blinking underscore, known as the cursor, appears on the display to indicate completion of the loading process.

Loading from a Flexible Disc Drive

The following is the procedure for loading your HP 250 system from the flexible disc drive.

1. Open the drive door by pressing the small bar on the drive. Insert the disc labeled SYSTEM into the drive until the disc clicks into place. Pull the drive door down so that it latches.



2. Insert the key and turn it clockwise to position 1. The drive door is locked automatically during loading. If the light indicating that the drive is in use never comes on, it may mean that the disc was inserted improperly. Open the drive door and remove the disc; retry the procedure.

3. A system self-test is automatically performed when the power is turned on. As the test is performed, a listing of system components is shown on the display of the principal workstation. If any component fails, the system is not operable. If this occurs, consult the section titled "In Case of Difficulty" in this manual.

If no problem occurs, a message in the form of:

SYSTEM LOADING

followed by:

LOADING DROMS

is shown. The message remains on the screen for about 30 seconds. The cursor, a blinking underscore, appears on the display to indicate completion of the loading process.

If the message:

The "SYSTEM" file was not found.

appears on the screen during loading, the operating system disc was not inserted into a drive or was inserted improperly. You should turn the key to the off position, insert the disc, and restart the loading procedure.

When the operating system is loaded, you may remove the flexible disc marked SYSTEM from the drive. You can now load another disc that may contain data or programs. See the section on "System Commands" that appears later in this manual.

If the result of the self-test is an error message or the system failed to power on, consult the section titled "In Case of Difficulty".

Loading from a HP 7906 Disc Drive

Follow this procedure to load the HP 250 Operating System from a HP 7906 removable cartridge.

1. If you have not already done so, open the drive door and mount the removable disc cartridge containing the system software into the HP 7906 drive.
2. Flip the HP 7906 STOP/RUN switch to the STOP position and then back to the RUN position.
3. Wait for the "DRIVE READY" indicator to light on the front panel of the HP 7906.
4. Insert the key into the lock located on your HP 250 system. Turn the key clockwise to position 1 to power on the HP 250. After the initial self-test is performed, the screen is cleared for approximately 20 seconds. When the loading process is completed, the cursor, a blinking underscore, is displayed.

If the message "System File Not Found." is displayed, you must repeat the system loading procedure from the beginning.

Using a 5 Mb. Disc Drive

Your 5 Mb. Disc drive is used to store files that you create. You cannot keep a copy of the operating system on this disc; load the system from your flexible disc drive.

The 5 Mb. Disc is powered on when you power on the HP 250. Therefore, when you load the operating system by following the instructions "Loading a Flexible Disc Drive" (in this chapter), you will also power-on your 5 Mb. Disc drive.

CHAPTER 3

Workstations

The Central Processing Unit (CPU) of the computer controls all other components of the system. It holds the operating system of the HP250, which is software associated with the computer and its processing capabilities. It also has at least 32K bytes of memory available to you for programs and data; user memory, capable of processing six tasks simultaneously, may be expanded to 384K bytes by additional memory options. The activity within the CPU is invisible to you.

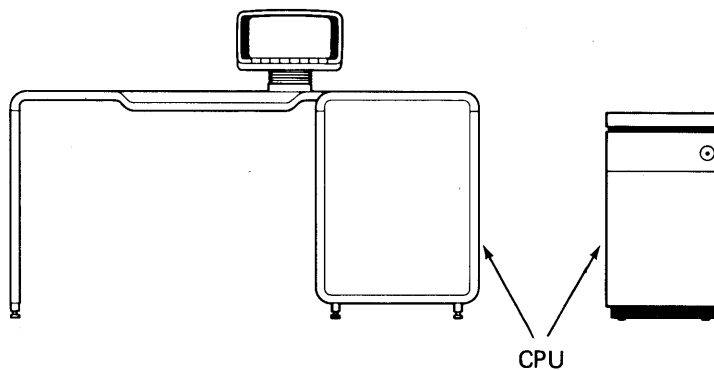

Your workstation, a combination of a keyboard and video display, is your path to the CPU. This chapter is divided into three sections, each of which describes one of the three possible HP 250 workstations. Based on the drawings below, turn to the appropriate section to learn about your workstation.



HP 2622D
Personal Workstation

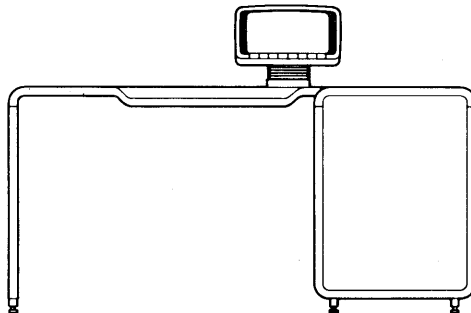



HP 250/35
Integrated Workstation



HP 2649D
Remote Workstation

The HP 2622D Personal Workstation

Display

The display is used to view program listings, information entered from the keyboard, and program output. The display memory can store more characters than shown on the screen at one time. The screen holds one page which consists of 24 lines of up to 80 characters each. If the display has been filled, the top line rolls off the screen. As you type a line, the display will roll up to make room for a new line. When viewing display lines, you may access lines preceding or following those currently on the screen by pressing the display editing keys  and . The illustration shows the scrolling process.

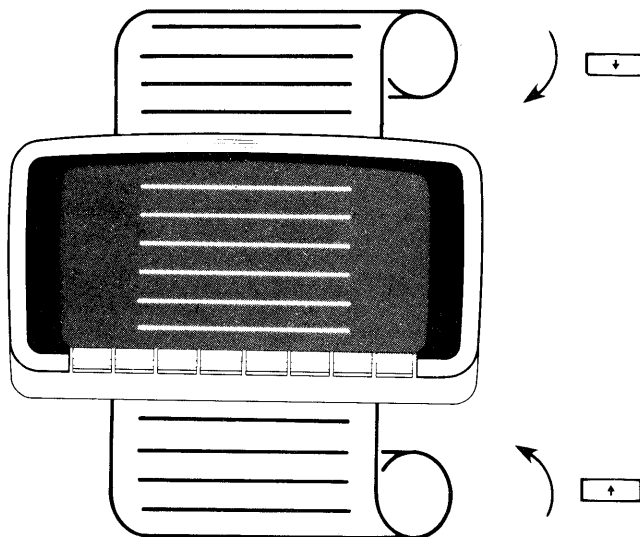

When your HP 250 is ready for operation, the cursor is visible on the screen.

The capabilities of the display are numerous. For example, characters may appear on the screen as half-bright, underlined, blinking, or inverse video (or any combination). These features can be accessed either from the keyboard or programmatically. Accessing these display enhancement features is described later in this section.

Thermal Printer (Optional)

As an option, the HP 2622D workstation can have an integral thermal printer to produce a hard copy of information. Generally speaking, it has two printing capabilities:

- 1) Display of screen contents - the printer can print the entire contents of what you see at any given time on the display. To learn how to do this, consult the section under "Printing a Screen Image on the Thermal Printer" in this chapter.
- 2) Display of all interactions with the system - the printer can record any or all interaction with the system such as file catalogs, transactions, and even program results. To learn how to do this, read the section titled "Output Commands" in Chapter 8.

For general information on the thermal printer (such as how to load paper), turn to Chapter 6.

Keyboard

The keyboard resembles a typewriter keyboard and is used to communicate with the computer. The keyboard consists of a typewriter block, a data entry pad, display editing keys, an execute key, a halt key, 3 remote keys, and 8 function keys. All of these keys are described in this section.

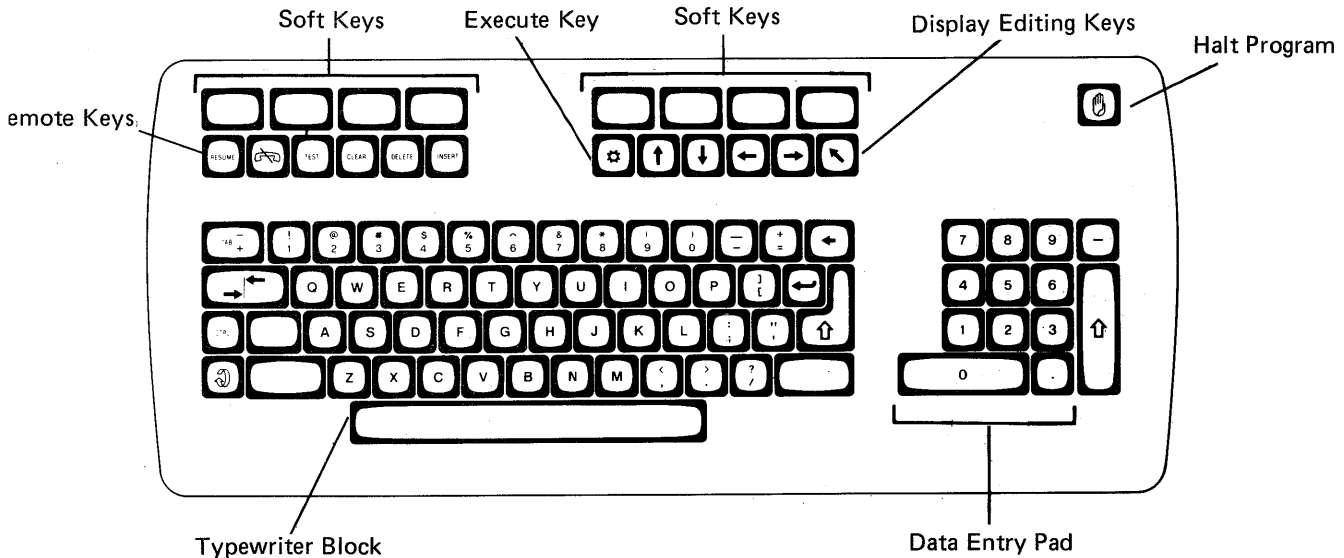

Typewriter Block

The typewriter block is used to input data or program lines. The alphabetic keys normally enter lower case characters. Use the shift key with the alphabetic keys to enter upper case characters. When you depress the CAPS-LOCK key, only alphabetical keys are shifted to upper case.

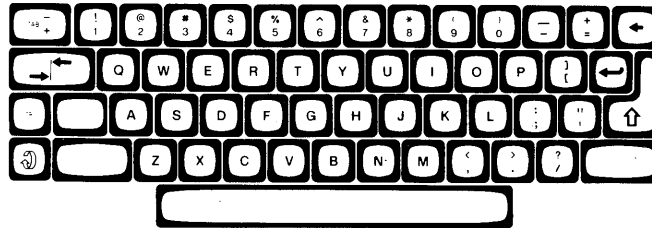

Typewriter Block

Several special control keys are located on the left and right sides of the keyboard block.



The SHIFT key enters upper case characters.



The CAPS-LOCK key locks only alphabetic keys to upper case characters. In order to access the shifted key characters on non-alphabetic keys, you must press the SHIFT key. For example, if you want to enter the \$ sign while the CAPS-LOCK key is depressed, you must press



The BACKSPACE key is used to move the display cursor toward the left margin.



The CARRIAGE RETURN key moves the cursor to the beginning of the next line. When SHIFT  is pressed, the cursor is moved to the beginning of the present line of input.



The ENTER key enters data into memory. It also executes the current command.



The SET TAB key allows you to set tabs and also clear them. You move the cursor to the desired position on the line and then press this key to set the tab. In order to delete any tab that you have set, move the cursor to the tab position, and press SHIFT .



The TAB key moves the cursor to the first character position of the next input field or tabbed position. If you press SHIFT , the cursor will be moved to the first character of the previous input field or to the previous tabbed position.



The CONTROL key is used to access special characters and commands as shown throughout this chapter.



The CYCLE key is used to access all 24 user-defined softkeys. This key is discussed in the section on softkeys, which appears later in this chapter.

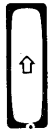

Data Entry Pad

Use this block of keys, located on the far right side of the keyboard to input numeric data rapidly.



Another ENTER key is conveniently placed on the side of the data entry pad.



Above the ENTER key of the data entry pad is the MINUS key. The MINUS key usually enters a negative sign when pressed. For example, if you perform this series of keystrokes:    then you have entered

-5. The MINUS key can also be configured to serve as an additional TAB key; see "Setting the HP 2622D Configuration".



Data Entry Pad

Display Editing Keys

These keys are used for modifying input and positioning the cursor at specific locations on the screen. Each of the keys is rapidly repeated by holding it down.



The CLEAR key clears the current line or field. If you press CONTROL CLEAR, only the characters from the present cursor position to the end of the current line are cleared from the display. If SHIFT CLEAR is pressed, all input fields are cleared from the cursor's present position to the end of the display storage area (which includes all lines below that are not currently displayed). If you press CONTROL SHIFT CLEAR, the entire display storage area is cleared (including all lines not currently displayed on the screen).



The DELETE key is used to delete the current character position of the cursor. If you press SHIFT DELETE, the entire current line is deleted from the display. Note that the current line can take up more than one row of the display screen.





The INSERT key allows you to insert characters to the left of the cursor. Press this key to enter the insert mode. You can now type in the characters you wish to insert. To exit from the insert mode, either press the INSERT key again or move the cursor from its current line (pressing the ENTER or EXECUTE key also exits you from insert mode since the cursor is automatically moved from the current line). You can tell if you are in insert mode by looking at the Status Display which is described on page 3-13. If you press SHIFT INSERT, a blank line is inserted preceding the current line; the cursor then appears at the first position of the new line.



These keys move the position to the left or right. If you hold them down, the cursor will move rapidly. The cursor wraps around to the next line if a margin is encountered. For example:



These keys move the cursor up or down one line from the current position on the display. Pressing SHIFT  and SHIFT  moves the cursor to the previous and next display page respectively. The sketch on page 3-2 describes this movement up or down, called **scrolling**.



The HOME key moves the cursor to the upper left of the display. When SHIFT HOME is pressed, the cursor is moved to the first character of the display storage area, which may be on a previous display page.

Execute Key



This key executes the current line or expression in the display. For example, if you typed in the following sequence:

$$8+22-7*11$$

then the value of the line is computed and output on the display.

Halt Key



This key halts a program at the end of a current operation. Unless overridden by the program, pressing the HALT key stops the program, and the next program line to be executed is displayed. Pressing the HALT key is not a normal way to stop a program, and may require reloading the program to resume operation.

You should note that if you are sending output to an HP 2601 printer, it may continue to print for a period of time even though you pressed the HALT key.

Press SHIFT HALT to stop the current program from executing and all Input/Output operations.

Press CONTROL HALT to abort all operations and clear the user work area.

IMPORTANT

You should use the HALT key with discretion. Data may be lost by halting a program.

Remote Keys

The remote keys, labeled RESUME, , and TEST, are located in the upper left hand corner of the keyboard.



The RESUME key allows you to request a total update of display information in the event of a data communication or other error that would cause the workstation to display incorrect data. When you press this key, the display storage area is erased and the remote workstation display is rewritten under the control of the HP 250 system.

NOTE

Pressing RESUME while data is being sent to a remote printer results in a loss of the data.



The TEST key initiates several diagnostic tests to verify the workstation's operation. The self-test is performed on a local basis; in other words, the test is performed even if the remote workstation is not connected to the HP 250. These diagnostic tests are described later in this section under the heading "Testing the HP 2622D"



The MODEM key is a local key that is significant when you are linked to the HP 250 system via a modem. It can be set as either active or inactive in the terminal configuration (see "Setting the HP 2622D Configuration"). When configured as active, pressing this key disconnects the modem; pressing it again connects the modem. You can see the status of this key by accessing the Status Display, as described on page 3-12.

Softkeys

There are eight softkeys located on the top portion of the keyboard.

You will most likely use these keys in conjunction with an application software program, a utility program (such as initializing media), or as typing aids; these are known as user-defined softkeys.

The HP 250 system also has its own defined softkeys which can be used to set the terminal configuration, display status information, display all softkey labels, and access alternate character sets (line drawing, display mode, and display enhancements).

User-Defined Keys

Each of the 8 keys can be defined 3 ways. In other words, it is possible to have 24 user-defined softkeys at any one time. These softkeys are appropriately numbered 1 through 24. The corresponding softkey labels appear on the screen when the keys are defined. Pressing a key activates a predefined program or routine that is stored in the computer's memory.

If you are running a program which has 24 softkeys defined, only 8 of the keys are available at any given time. In other words, you will see the definitions of either softkeys 1-8, 9-16, or 17-24 at any one time. To activate the next set of softkeys and display the corresponding labels, press the CYCLE key located on the lower left hand side of the typewriter block.

Below is an example of softkey labels on the display screen.

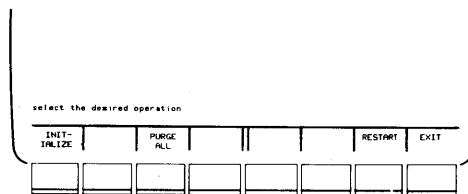

To learn more about using softkeys as typing aids, you should look at the appendix titled "Using Softkeys as Typing Aids".

System Defined Keys

You can access several special functions defined by the system by pressing softkeys simultaneously with either the SHIFT or CONTROL keys. These are known as the Control Function Key Set and the Shift Function Key Set.

Shift Function Keys

The shift function key set contains system-defined keys which you can use to configure your workstation, display the screen contents to the optional thermal printer, show a status display, and display all softkey labels.

Setting 2622D Configuration

You configure the 2622D workstation by pressing:

SHIFT and f1

and then selecting the options by using softkeys. The following screen appears:

WORKSTATION CONFIGURATION							
Baud Rate		Frame Rate					
Minus Key		Modem Key					
		Chars/Line					
SAVE CONFIG	NEXT CHOICE	PREVIOUS CHOICE	DEFAULT VALUES				

To change the option for any setting, use the TAB key to position the cursor within the field you wish to change, and then use the softkeys labeled NEXT CHOICE and PREVIOUS CHOICE to select the proper values. The DEFAULT VALUES softkey sets the options to system-defined values. When you have all values exactly as you want them, press the SAVE CONFIG softkey to record your new configuration and exit.

Printing a Screen Image to Thermal Printer

If your workstation has a thermal printer, you can print the contents of the display screen on the thermal printer by pressing:

SHIFT and F4

Remember that you can specify the character width to be printed when setting the configuration of the workstation.

A sample screen image is shown below.

```

CAT ":Q"
NAME  PRO  TYPE  REC/FILE  BYTES/REC  ADDRESS
:G2,7,0
SYSTEM *  SYST      600      256      1260
EUROPE    DROM       4       256      1860
PACK      DROM       7       256      1864
IMAGE     DROM      72       256      1871
SORT      DROM      29       256      1943
REPORT    DROM      30       256      1972
FORMS     DROM       6       256      2002
EUR71     DROM       3       256      2008
RIO       DROM      19       256      2011
TIO       DROM      23       256      2030
TRACE     DROM       9       256      2053
P2608    DROM       7       256      2062
TRIG      DROM       7       256      2069
MATRIX    DROM      22       256      2076
SPOGL     DROM      11       256      2098
CS250    DROM      55       256      2109
MEDIA     DROM      42       256      2164
IMAGE2    DROM      14       256      2206
TASK      DROM       8       256      2220
COPY      DROM       4       256      2228
IMAGEU    DROM      15       256      2232
    
```

The Status Display

By pressing SHIFT f5, you can display the following information:

1. Softkey Set Status
2. Modem Status
3. Insert Character Status

The last two lines of the screen are reserved for the status display. Regardless of the setting of the status display, you have 24 lines of the screen available when softkey labels are off; when softkey labels are on, you have 21 lines available.

To remove the status display from the screen, press SHIFT f5 again.

Softkey Set Status

You can see which user-defined softkey status is active at any given time. The sets are defined as Set 1 (Keys 1-8), Set 2 (9-16), and Set 3 (17-24). When you press the CYCLE key, this value automatically changes to reflect the new set of active keys.

Modem Status

The modem status is only meaningful when your workstation is connected via a modem. The status is defined as either "MODEM ON" or "MODEM OFF" depending on your use of the MODEM key (the MODEM key is defined in the section on Remote Keys).

Insert Character Status

You can tell whether or not you are in insert mode by looking at the information displayed in the lower right hand corner of the Status Display. When you press the INSERT key, the information on the display changes from OFF to ON or vice versa.

Displaying All Softkey Labels

To display all user-defined and system-defined softkeys at one time press:

SHIFT and f8

The display appears as shown below.

CONTROL FUNCTION KEYS

ALTERNATE CHAR SET			DISPLAY FUNCTIONS	INVERSE VIDEO	BLINKING	UNDERLINE	HALF BRIGHT
-----------------------	--	--	----------------------	------------------	----------	-----------	----------------

SHIFT FUNCTION KEYS

TERMINAL CONFIG			PRINT DISPLAY	STATUS DISPLAY			LABELS DISPLAY
--------------------	--	--	------------------	-------------------	--	--	-------------------

--	--	--	--	--	--	--	--

--	--	--	--	--	--	--	--

--	--	--	--	--	--	--	--

SOFTKEY SET 3

INSERT CHARACTER OFF

To turn off the softkey display mode, press SHIFT f8 again.

Control Function Keys

You can access several alternate character sets by pressing the CONTROL key in conjunction with a softkey. These character sets include a line drawing set, a display character control set, and display enhancement sets (half-bright, blinking, inverse video, and underlining).

CONTROL FUNCTION KEYS

ALTERNATE CHAR SET		DISPLAY FUNCTIONS	INVERSE VIDEO	BLINKING	UNDERLINE	HALF BRIGHT
-----------------------	--	----------------------	------------------	----------	-----------	----------------

Characters from these alternate sets may be intermixed in display operations, included in string variables, and, in general, handled like the standard Roman alphanumeric character set. These alternate characters, however, may not be recognized by most external devices (including printers).

Each alternate character set is accessed by a unique CONTROL-key sequence with the softkeys.

Line Drawing Character Set

You access the line drawing set by pressing the following key sequence.

CONTROL and f1

To exit the line drawing character mode, press the following:

SHIFT and CONTROL and f1

Display Character Set

You access the display control character set by pressing the following key sequence:

CONTROL and f4

To exit the display control character set, you press the following sequence of keys:

SHIFT and CONTROL and f4

One typical use of these display control characters involves the definition of softkeys as typing aids. For a more detailed discussion, see the section in this book titled "Using Softkeys as Typing Aids".

Display Enhancement Set

As mentioned before, there are 4 modes of display enhancement: inverse video, half-bright, underlined, and blinking characters. Any combination of enhancements can be set. These alternate characters are not recognized by most external output devices, such as printers.

The display enhancements are accessed by pressing the CONTROL key and the appropriate softkey, as shown in the next figure.

CONTROL FUNCTION KEYS

ALTERNATE CHAR SET		DISPLAY FUNCTIONS	INVERSE VIDEO	BLINKING	UNDERLINE	HALF BRIGHT
-----------------------	--	----------------------	------------------	----------	-----------	----------------

To turn off any of the display enhancements, press the SHIFT key, the CONTROL key, and the appropriate softkey simultaneously.

The HP 250/35 Integral Workstation

Display

The display is used to view program listings, information entered from the keyboard, and program output. The display memory can store more characters than shown on the screen at one time. The screen holds one page which consists of 24 lines of up to 80 characters each. If the display has been filled, the top line rolls off the screen. As you type a line, the display will roll up to make room for a new line. When viewing display lines, you may access lines preceding or following those currently on the screen by pressing the display editing keys and . The illustration shows the scrolling process.

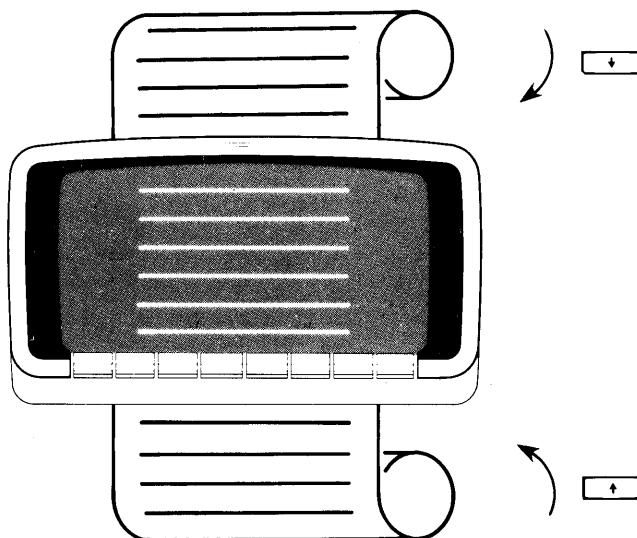

When your HP 250 is ready for operation, a blinking underscore, known as the cursor, is visible on the screen.

The capabilities of the display are numerous. For example, characters may appear on the screen as half-bright, underlined, blinking, or inverse video (or any combination). These features can be accessed either from the keyboard or programmatically. Accessing these display enhancement features is described later in this chapter.

Keyboard

The keyboard resembles a typewriter keyboard and is used to communicate with the computer. The keyboard consists of a typewriter block, a data entry pad, display editing keys, an execute key, and special function keys (known as softkeys). All of these keys are described in this section.

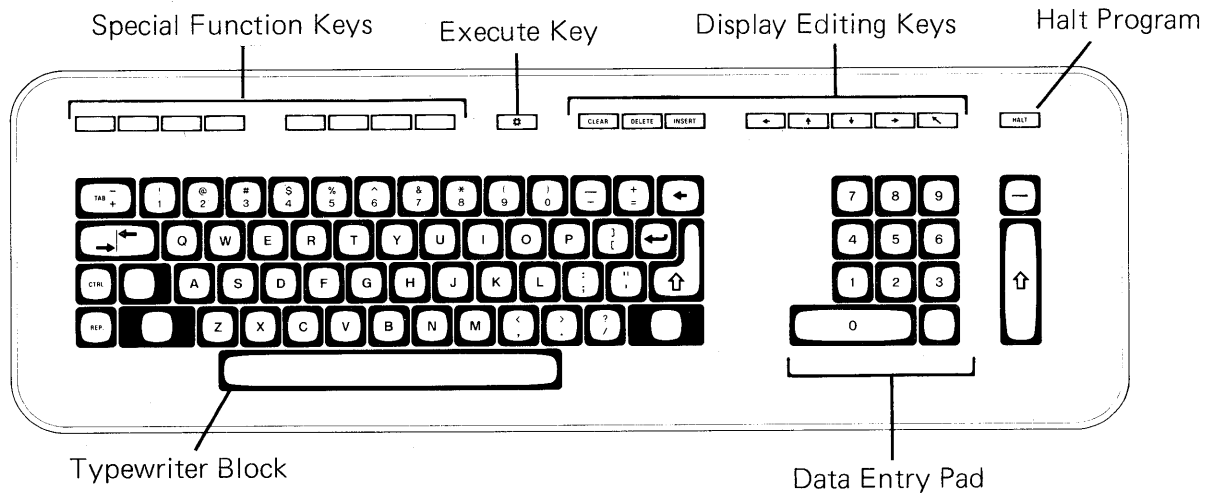

Typewriter Block

The typewriter block is used to input data or program lines. The alphabetic keys normally enter lower case characters. Use the SHIFT key with the alphabetic keys to enter upper case characters. When you depress the caps-lock key, only alphabetical keys are shifted to upper case.

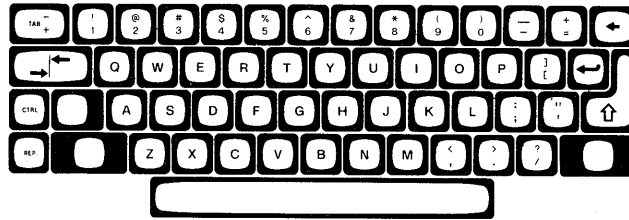





Typewriter Block



Several special control keys are located on the left and right sides of the keyboard block.

- 

The SHIFT key enters upper case characters.
- 



The CAPS-LOCK key locks only alphabetic keys to upper case characters. In order to access the shifted key characters on non-alphabetic keys, you must press the SHIFT key. For example, if you want to enter the \$ sign while the CAPS-LOCK key is depressed, you must press  .
- 

The BACKSPACE key is used to move the display cursor toward the left margin.
- 

The CARRIAGE RETURN key moves the cursor to the beginning of the next line. When SHIFT  is pressed, the cursor is moved to the beginning of the present line of input.
- 

The ENTER key enters data into memory. It also executes the current command.
- 

The SET TAB key allows you to set tabs and also clear them. You move the cursor to the desired position on the line and then press this key to set the tab. In order to delete any tab that you have set, move the cursor to the tab position, and press SHIFT
- 





The TAB key moves the cursor to the first character position of the next input field or tabbed position. If you press SHIFT , the cursor will be moved to the first character of the previous input field or to the previous tabbed position.
- 

The CONTROL key is used to access special characters and commands as shown throughout this chapter.
- 

When pressed simultaneously with another key, the REPEAT key causes that key to be repeated.

Data Entry Pad

You use this block of keys, located on the far right side of the keyboard to input numeric data rapidly.

-  Another ENTER key is conveniently placed on the side of the data entry pad.
-  Above the ENTER key of the data entry pad is the MINUS key. The MINUS key usually enters a negative sign when pressed. For example, if you perform this series of keystrokes:    then you have entered -5.

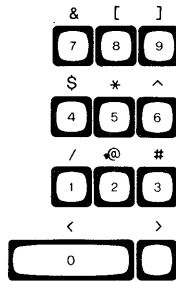

Data Entry Pad

Display Editing Keys

These keys are used for modifying input and positioning the cursor at specific locations on the screen. Each of the keys is rapidly repeated by holding it down.

-  The CLEAR key clears the current line or field. If you press CONTROL CLEAR, only the characters from the present cursor position to the end of the current line are cleared from the display. If SHIFT CLEAR is pressed, all input fields are cleared from the cursor's present position to the end of the display storage area (which includes all lines below that are not currently displayed). If you press CONTROL SHIFT CLEAR, the entire display storage area is cleared (including all lines not currently displayed on the screen).



The DELETE key is used to delete the current character position of the cursor. If you press SHIFT DELETE, the entire current line is deleted from the display.



The INSERT key allows you to insert alphanumeric characters to the left of the cursor. Press this key to enter the insert mode. The cursor appears within an inverse video box. You can now type in the characters you wish to insert. To exit from the insert mode, either press the INSERT key again or move the cursor from its current line; the cursor reverts to its normal appearance. If you press SHIFT INSERT, a blank line is inserted preceding the current line; the cursor appears at the first position of the new line.



These keys move the position to the left or right. If you hold one down, the cursor moves rapidly in that direction. The cursor wraps around to the next line if a margin is encountered. For example:

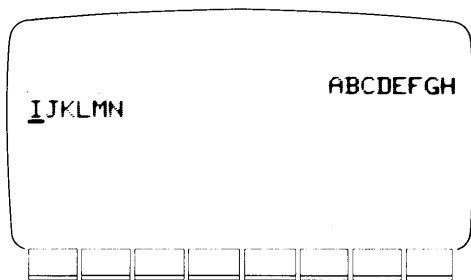

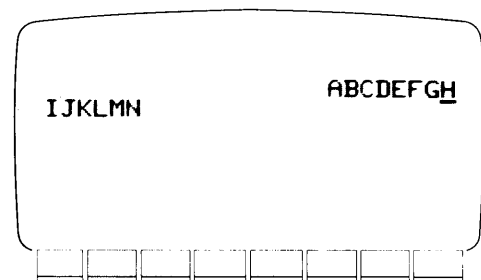

Cursor Positioned at Left Margin



Pressing  Moves Cursor to Previous Line





These keys move the cursor up or down one line from the current position on the display. Pressing SHIFT  and SHIFT  moves the cursor to the previous and next display page respectively. The sketch on page 3-16 describes this movement up or down, which is called scrolling.



The HOME key moves the cursor to the upper left of the display. When SHIFT  is pressed, the cursor is moved to the first character of the display storage area, which may be on a previous display page.

Execute Key

 This key executes the current line or expression in the display. For example, if you typed in the following sequence:

$8+22-7*11$ 

then the value of the line is computed and output on the display.

Halt Key

 This key halts a program at the end of a current operation. Unless overridden by the program, pressing the HALT key stops the program, and the next program line to be executed is displayed. Pressing the HALT key is not a normal way to stop a program, and may require reloading the program to resume operation.

You should note that if you are sending output to an HP 2601 printer, it may continue to print for a period of time even though you pressed the HALT key.

Press SHIFT HALT to stop the current program from executing and all Input/Output operations.

Press CONTROL HALT to abort all operations and clear the user work area.

IMPORTANT

You should use the HALT key with discretion. Data may be lost by halting a program.

Softkeys

The softkeys consist of 8 keys each on the keyboard and the display.

You will most likely use these keys in conjunction with an application software program, a utility program (such as initializing media), or as typing aids; these are known as user-defined softkeys. Pressing each key runs a pre-defined program or routine stored in the computer memory.

User Defined Softkeys

The softkeys located on the display are numbered from 1 through 8. The softkeys on the keyboard contain the sets 9-16 and 17-24. Softkeys 9-16 are accessed by pressing the appropriate key on the keyboard; softkeys 17-24 are accessed by pressing the SHIFT key and the appropriate key on the keyboard.

When softkeys 1-8 are defined, their definitions appear on the display. This reduces the amount of lines the screen can hold from 24 to 21. The definitions for softkeys 9-24 are not shown on the display.

Below is an example of softkey labels on the display screen.

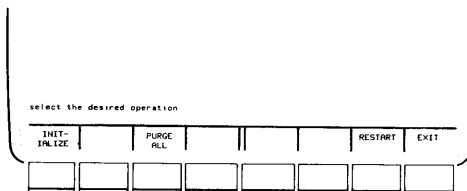

To learn more about using softkeys as typing aids, you should look at the appendix titled "Using Softkeys as Typing Aids".

Control Function Keys

You can access several alternate character sets by pressing the CONTROL key in conjunction with a softkey. These character sets include a line drawing set, a display character control set, and display enhancement sets (half-bright, blinking, inverse video, and underlining).

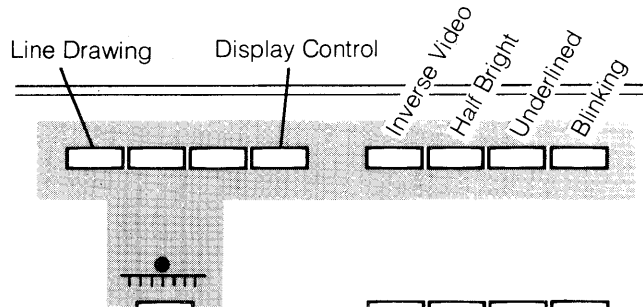

Characters from these alternate sets may be intermixed in display operations, included in string variables, and, in general, handled like the standard Roman alphanumeric character set. These alternate characters, however, may not be recognized by most external devices (including printers).

Each alternate character set is accessed by a unique CONTROL-key sequence with the softkeys.

Line Drawing Character Set

You access the line drawing set by pressing the following key sequence.

CONTROL and Softkey #9

To exit the line drawing character mode, press the following:

SHIFT and CONTROL and Softkey #9

Display Character Set

You access the display control character set by pressing the following key sequence:

CONTROL and Softkey #12

To exit the display control character set, you press the following sequence of keys:

SHIFT and CONTROL and Softkey #12

One typical use of these display control characters involves defining softkeys as typing aids. For a more detailed discussion, see the section in this book titled "Using Softkeys as Typing Aids".

Display Enhancement Set

As mentioned before, there are 4 modes of display enhancement: inverse video, half-bright, underlined, and blinking characters. Any combination of enhancements can be set. These alternate characters are not recognized by most external output devices, such as printers.

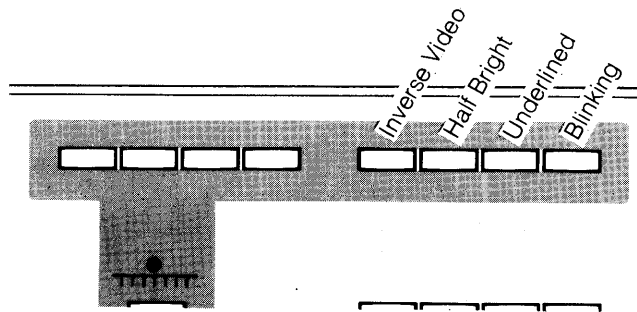

The display enhancements are accessed by pressing the CONTROL key and the appropriate softkey, as shown in the figure below.



To turn off any of the display enhancements, press the SHIFT key, the CONTROL key, and the appropriate softkey simultaneously.

The HP 2649D Workstation

Display

The display is used to view program listings, information entered from the keyboard, and program output. The display memory can store more characters than shown on the screen at one time. The screen holds one page which consists of 24 lines of up to 80 characters each. If the display has been filled, the top line rolls off the screen. As you type a line, the display will roll up to make room for a new line. When viewing display lines, you may access lines preceding or following those currently on the screen by pressing the display editing keys  and . The illustration shows the scrolling process.

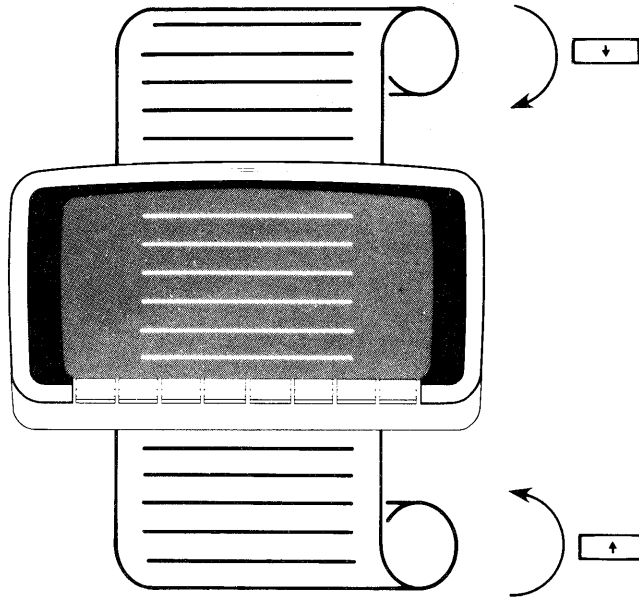

When your HP 250 is ready for operation, the cursor is visible on the screen.

The capabilities of the display are numerous. For example, characters may appear on the screen as half-bright, underlined, blinking, or inverse video (or any combination). These features can be accessed either from the keyboard or programmatically. Accessing these display enhancement features is described later in this chapter.

Keyboard

The keyboard resembles a typewriter keyboard and is used to communicate with the computer. The keyboard consists of a typewriter block, a data entry pad, display editing keys, an execute key, a mode key, and special function keys (known as softkeys). All of these keys are described in this section.

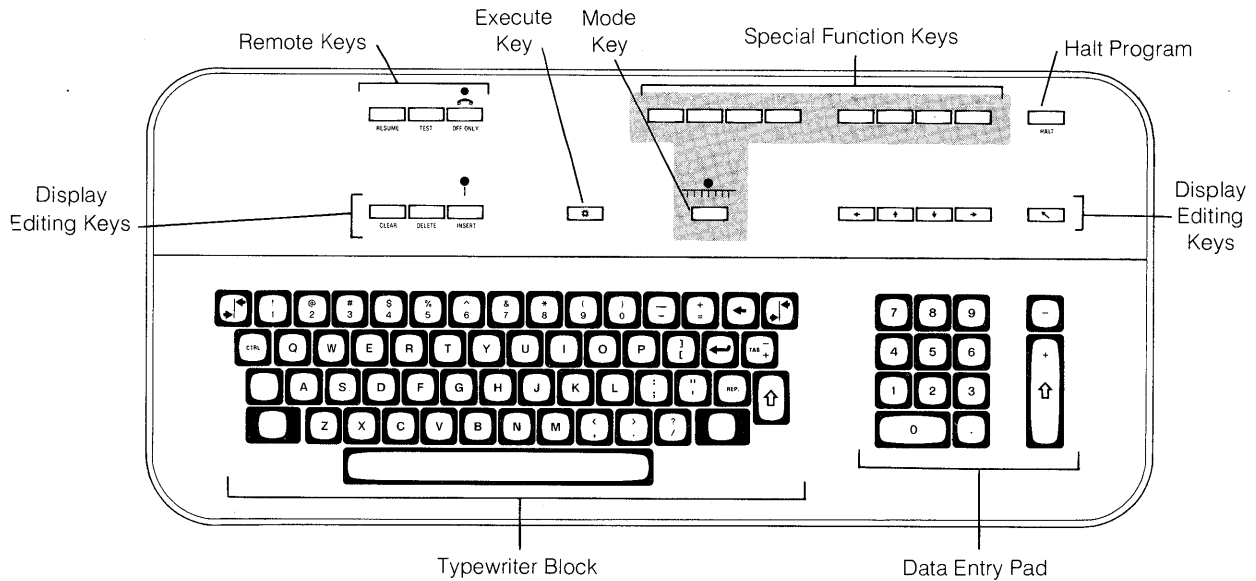

Typewriter Block

The typewriter block is used to input data or program lines. The alphabetic keys normally enter lower case characters. Use the shift key with the alphabetic keys to enter upper case characters. When you depress the caps-lock key, only alphabetical keys are shifted to upper case.

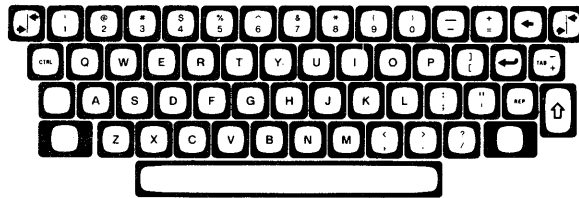





Typewriter Block



Several special control keys are located on the left and right sides of the keyboard block.

- 



The SHIFT key enters upper case characters.
- 



The CAPS-LOCK key locks only alphabetic keys to upper case characters. In order to access the shifted key characters on non-alphabetic keys, you must press the SHIFT key. For example, if you want to enter the \$ sign while the CAPS-LOCK key is depressed, you must press  .
- 

The BACKSPACE key is used to move the display cursor toward the left margin.
- 

The CARRIAGE RETURN key moves the cursor to the beginning of the next line. When SHIFT  is pressed, the cursor is moved to the beginning of the present line of input.
- 

The ENTER key enters data into memory. It also executes the current command.
- 

The SET TAB key allows you to set tabs and also clear them. You move the cursor to the desired position on the line and then press this key to set the tab. In order to delete any tab that you have set, move the cursor to the tab position, and press SHIFT .
- 

The TAB key moves the cursor to the first character position of the next input field or tabbed position. If you press SHIFT , the cursor will be moved to the first character of the previous input field or to the previous tabbed position.
- 

The CONTROL key is used to access special characters and commands as shown throughout this chapter.
- 

When pressed simultaneously with another key, the REPEAT key causes that key to be repeated. This key does not apply to the remote keys (TEST, MODEM, )

Data Entry Pad

You use this block of keys, located on the far right side of the keyboard to input numeric data rapidly.



Another ENTER key is conveniently placed on the side of the data entry pad.



Above the ENTER key of the data entry pad is the MINUS key. The MINUS key usually enters a negative sign when pressed. For example, if you perform this series of keystrokes:

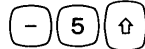

then you have entered -5.

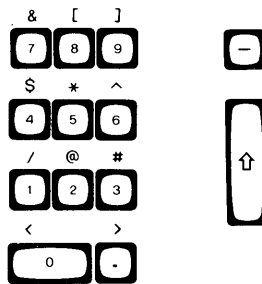

Data Entry Pad

Display Editing Keys

These keys are used for modifying input and positioning the cursor at specific locations on the screen. Each of the keys is rapidly repeated by holding it down.



The CLEAR key clears the current line or field. If you press CONTROL CLEAR, only the characters from the present cursor position to the end of the current line are cleared from the display. If SHIFT CLEAR is pressed, all input fields are cleared from the cursor's present position to the end of the display storage area (which includes all lines below that are not currently displayed). If you press CONTROL SHIFT CLEAR, the entire display storage area is cleared (including all lines not currently displayed on the screen).



The DELETE key is used to delete the current character position of the cursor. If you press SHIFT DELETE, the entire current line is deleted from the display.



The INSERT key allows you to insert alphanumeric characters to the left of the cursor. Press this key to enter the insert mode. The cursor appears within an inverse video box. You can now type in the characters you wish to insert. To exit from the insert mode, either press the INSERT key again or move the cursor from its current line; the cursor reverts to its normal appearance. If you press SHIFT INSERT, a blank line is inserted preceding the current line; the cursor appears at the first position of the new line.



These keys move the position to the left or right. If you hold one down, the cursor moves rapidly in that direction. The cursor wraps around to the next line if a margin is encountered. For example:

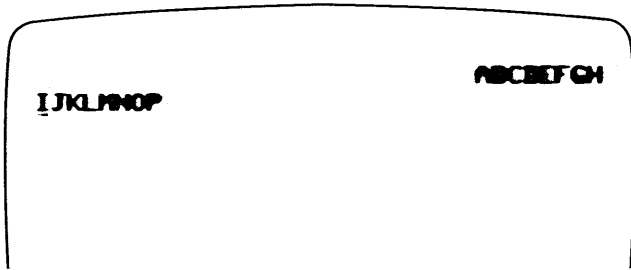

Cursor Positioned at Left Margin

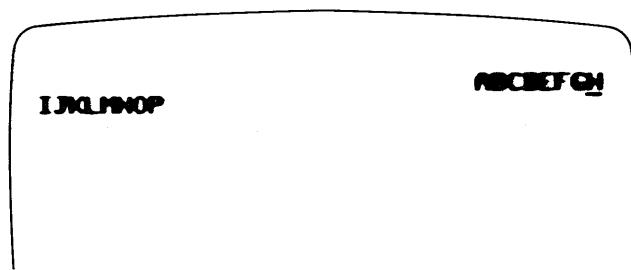

Pressing Moves Cursor to Previous Line



These keys move the cursor up or down one line from the current position on the display. Pressing SHIFT and SHIFT moves the cursor to the previous and next display page respectively. The sketch on page 3-25 describes this movement up or down, which is called scrolling.



The HOME key moves the cursor to the upper left of the display. When SHIFT is pressed, the cursor is moved to the first character of the display storage area, which may be on a previous display page.

Execute Key



This key executes the current line or expression in the display. For example, if you typed in the following sequence:

8+22-7*11

then the value of the line is computed and output on the display.

Halt Key



This key halts a program at the end of a current operation. Unless overridden by the program, pressing the HALT key stops the program, and the next program line to be executed is displayed. Pressing the HALT key is not a normal way to stop a program, and may require reloading the program to resume operation.

You should note that if you are sending output to an HP 2601 printer, it may continue to print for a period of time even though you pressed the HALT key.

Press SHIFT HALT to stop the current program from executing and all Input/Output operations.

Press CONTROL HALT to abort all operations and clear the user work area.

IMPORTANT

You should use the HALT key with discretion. Data may be lost by halting a program.

Remote Keys

The three keys labeled RESUME, TEST, and MODEM are located in the upper left hand portion of the 2649D.



The RESUME key allows you to request a total update of display information in the event of a data communications or other error that would cause the workstation to display incorrect data. When this key is pressed, the display storage area is erased and pointers of the remote workstation are reset. Then the data is rewritten to the display storage area from the CPU.

NOTE

Pressing the RESUME key while data is being sent to the remote printer results in a loss of data.



The TEST key initiates several diagnostic tests to verify the remote workstation's operation. The self test is performed on a local basis, even if the remote workstation is not connected to the HP250. The tests are described later in this chapter under the heading "Testing the HP 2649D Workstation".



The MODEM key initiates a modem disconnect. The hardware to support this function is optional. The transmit light located directly above the MODEM key indicates the physical connection to the HP250. If the light is not on, either the main workstation is not powered on or there is a failure in the data comm channel. The transmit light is only operative when the Extended Data Comm option (HP 13260B) is present.

Softkeys

The softkeys consist of 8 keys located on the keyboard. You will most likely use these keys in conjunction with an application software program, a utility program (such as initializing media), or as typing aids; these are known as user-defined softkeys.

User Defined Softkeys

Each of the 8 softkeys can have up to 3 definitions (thus, it is possible to have 24 softkeys defined at any one time). To use the first set of definitions, softkeys 1-8, the mode light located beneath the keys must be on; to turn the mode light on and off, press . When the mode light is off, softkeys 9-16 and 17-24 are defined. Softkeys 9-16 are accessed by pressing the associated key; softkeys 17-24 are accessed by pressing the SHIFT key and the associated key.

When softkeys 1-8 are defined, their definitions appear on the display. This reduces the amount of lines the screen can hold from 24 to 21. The definitions for softkeys 9-24 are never shown on the display.

Below is an example of softkey labels on the display screen.

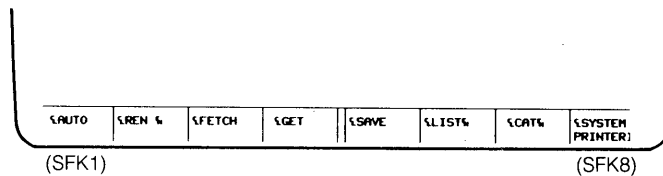

To learn more about using softkeys as typing aids, you should look at the chapter titled "Using Softkeys as Typing Aids".

Control Function Keys

You can access several alternate character sets by pressing the CONTROL key in conjunction with a softkey. These character sets include a line drawing set, a display character control set, and display enhancement sets (half-bright, blinking, inverse video, and underlining).

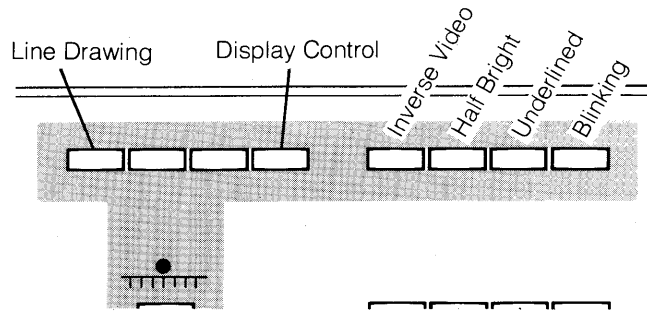

Characters from these alternate sets may be intermixed in display operations, included in string variables, and, in general, handled like the standard Roman alphanumeric character set. These alternate characters, however, may not be recognized by most external devices (including printers).

Each alternate character set is accessed by a unique CONTROL-key sequence with the softkeys.

Line Drawing Character Set

You access the line drawing set by pressing the following key sequence.

CONTROL and Softkey #1

To exit the line drawing character mode, press the following:

SHIFT and CONTROL and Softkey #1

Display Character Set

You access the display control character set by pressing the following key sequence:

CONTROL and Softkey #4

To exit the display control character set, press the following sequence of keys:

SHIFT and CONTROL and Softkey #4

One typical use of these display control characters involves the definition of softkeys as typing aids. For a more detailed discussion, see the section in this book titled "Using Softkeys as Typing Aids".

Display Enhancement Set

As mentioned before, there are 4 modes of display enhancement: inverse video, half-bright, underlined, and blinking characters. Any combination of enhancements can be set. These alternate characters are not recognized by most external output devices, such as printers.

The display enhancements are accessed by pressing the CONTROL key and the appropriate softkey, as shown in the figure below.

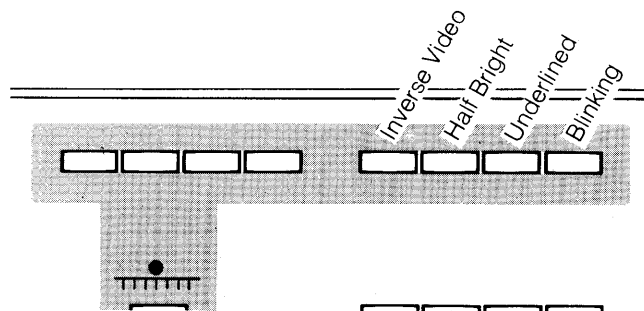

To turn off any of the display enhancements, press the SHIFT key, the CONTROL key, and the appropriate softkey simultaneously.

Testing the 2649D Workstation

By pressing the TEST key on the upper left corner of the keyboard, you initiate a general workstation self-test. The test works on a local basis only and does not require a data communications link to the HP 250. This self test is performed in the following sequence:

1. The display is cleared and any output to the remote printer is stopped.
2. The keyboard lights are turned on.
3. Each installed ROM (Read Only Memory) is tested and checked for proper placement.
4. A pattern test is performed on the display memory. The pattern is shown in the next diagram.
5. The HP-IB interface is tested if the firmware ROM is present on the workstation.
6. The bell is beeped.
7. All character sets (including foreign character sets if included in the hardware are displayed on the screen. This is shown in the next diagram.
8. An enhancement pattern is displayed.
9. Status information is displayed.

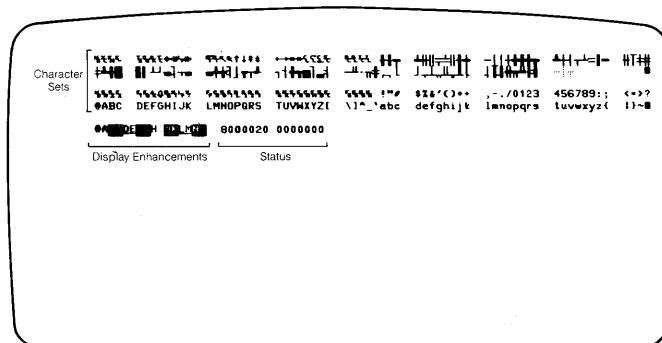

If an error occurs during step 3,4, or 5, the test is stopped and the appropriate error message is displayed. Press RESUME to remove the error message. If no errors occur during the test, the test pattern remains on the screen until you press RESUME or CNTL HALT.

If nothing happens when you press the TEST key, check that the workstation is plugged into an electrical outlet and the power switch is turned on.

Extended Tests

By pressing CTRL TEST, you initiate a set of extended tests. These tests check the keyboard matrix, lights, and switches. When CTRL TEST is pressed, the following message is displayed on the screen:

ENTER EXTENDED TEST NO. (1-4)

You can press either the space bar or RESUME to exit, or you can type the number of the desired test.

Test	Function
----	-----
1	Repeat test indefinitely
2	Keyboard matrix test
3	Data comm switch test
4	Keyboard LEDs test

Once one of the extended tests is entered, the space bar must be pressed to exit the function and return to the selection menu.

Test 1

REPEAT TEST - This function repeats both the general self-test and the data comm self-test until either an error is detected or you interrupt by pressing RESUME or the space bar. If the switch which inhibits the data comm test is open, the data comm portion of the test is never executed.

To exit the test, press the space bar.

Test 2

KEYBOARD MATRIX TEST - When this test is entered, Key Matrix is displayed in the upper left hand corner of the screen. A 40 column by 6 row display represents the position of the keys.

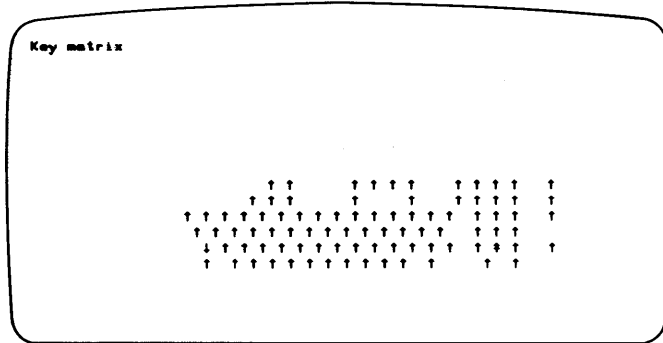

For every key on the keyboard (except RESUME) a vertical arrow is displayed in a corresponding position on the screen. If a key is pressed, the corresponding arrow on the display is changed from an upward pointing arrow to a downward pointing arrow. When the key is released, its arrow is changed to an upward pointing double-headed arrow. Pressing the key again changes the arrow to a downward pointing double-headed arrow. The progression is shown in the following figure



If the processor detects an input for a key that is not supposed to be on the keyboard, a DEL character is displayed in the lower right corner of this display. The visual feedback provided by this test allows you to quickly identify malfunctioning keys or groups of keys.

To exit the test, press the space bar once.

Test 3

DATA COMMUNICATION SWITCH TEST - The data comm switches (baud rate, parity, and duplex) are tested in extended test number 3. When in this test state, "Data communication switches" is displayed above a graphic display of the actual switch settings. This display is continuously updated as the switches are changed. The following figures shows how the display would look for full duplex, 9600 baud, and odd parity.

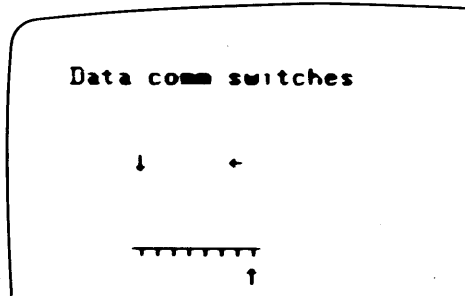

If the duplex switch is left on HALF or the baud rate switch is left on EXT, when the space bar is pressed, the message "IMPROPER SETTINGS" is displayed until they both are corrected. (This is done since the workstation will not work with the HP 250 for these settings.)

Test 4

KEYBOARD LEDs TEST - When the keyboard light test is entered, Keyboard LEDs is displayed and all of the LEDs are turned off. The user may then toggle each LED by pressing the key below it. The space bar must be pressed to exit this test.

CHAPTER 4

Keyboard Operations

Solving Arithmetic Problems

The data entry pad can be used to solve arithmetic problems. The range of numbers that your HP 250 can handle - or the smallest through the largest numbers that the machine can print - is approximately -10×10^{99} through $+10 \times 10^{99}$.

While the system is computing, the cursor is not shown on the display. You cannot enter any information from the keyboard during this time.

Numerical results can appear in 3 forms: integer, decimal, and scientific notation. Example computations illustrate the 3 output forms:

Integer Result

```
8+22
 30
-
```

Decimal Result

```
4.7+5.7
 10.4
-
```

Scientific Notation Result

```
1.93E55*10
 1.930000000000E+56
-
```

Keyboard Operations

The most frequently used operators are + (addition), - (subtraction), / (division), * (multiplication), and ^ (or **) (exponentiation).

For example, in order to compute the sum of 8 and 22, press the following key sequence:

(8) (SHIFT) (+) (2) (2) (=)

```
8+22
 30
-
```

More complicated problems can be solved as well. When you press this series of keys, it is equivalent to the problem $9*8+(7-2)+10$ being solved:

(9) (SHIFT) (*) (8) (SHIFT) (+) (SHIFT) (7) (-) (2) (SHIFT) (/) (SHIFT) (+) (1) (0) (=)

```
9*8+(7-2)+10
 87
-
```

You cannot multiply numbers without using the operator *. The expression AB, which indicates "A times B" in algebra, is not interpreted as multiplication by the computer. You must enter **A*B**.

The computer performs operations in a preset order called a mathematical hierarchy. For keyboard operations, you need to remember that exponentiation has higher priority than multiplication and division. Multiplication and division have higher priorities than addition and subtraction. Below is an abbreviated list of the mathematical hierarchy, with parentheses having the highest priority.

Symbol	Description
()	parentheses
^ (or **)	exponentiation
* , /	multiplication, division
+ , -	addition, subtraction

Here are several examples:

1) To solve the problem $3+(2*5)$, press: $\text{3} \text{SHIFT} \text{+} \text{SHIFT} \text{9} \text{2} \text{SHIFT} \text{*} \text{SHIFT} \text{5} \text{SHIFT} \text{)} \text{=}$

$$\begin{array}{r} 3+(2*5) \\ 13 \\ - \end{array}$$

This is the equivalent of $3+2*5$, even though no parentheses are present. If two operators have equal priority in an expression (such as $*$ and $/$), then the operations are performed from left to right. Multiplication has priority over addition, however, so the expression $2*5$ is performed first. When parentheses are included, the computer evaluates the quantities in parentheses first.

2) To solve $(10-5)*(8/4)$, press:

$\text{SHIFT} \text{9} \text{1} \text{0} \text{SHIFT} \text{-} \text{SHIFT} \text{5} \text{SHIFT} \text{)} \text{SHIFT} \text{*} \text{SHIFT} \text{9} \text{8} \text{SHIFT} \text{/} \text{SHIFT} \text{3} \text{4} \text{SHIFT} \text{)} \text{=}$

$$\begin{array}{r} (10-5)*(8/4) \\ 10 \\ - \end{array}$$

If no parentheses were used in the key series above:

$\text{1} \text{0} \text{SHIFT} \text{-} \text{SHIFT} \text{*} \text{SHIFT} \text{8} \text{SHIFT} \text{/} \text{4} \text{=}$

then the expression would be evaluated in this way. First 5 would be multiplied by 8 giving 40. Second, this value 40 would be divided by 4 giving 10. And third, the value 10 would be subtracted from 10 giving 0.

$$\begin{array}{c} 10-5*8/4 \\ \underbrace{\quad\quad\quad}_1 \\ \underbrace{\quad\quad\quad}_2 \\ \underbrace{\quad\quad\quad}_3 \end{array}$$

So it is obvious that the use of parentheses (or their omission) can affect results. When in doubt, put parentheses in an expression, since all extra sets of parentheses are ignored.

Correcting Typographical Errors

If you enter an incorrect command, the HP 250 responds with an error message. The most frequent errors are typographical in nature. In order to correct a typographical error, use the display editing keys described in the "Keyboard" section of this manual. If, for example, you had typed this input:

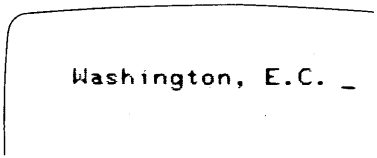

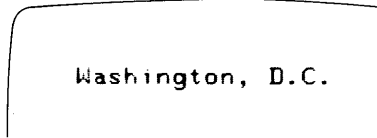

```
Washington, E.C. _
```

and had wanted to type:



```
Washington, D.C.
```

press the  or  key until the cursor moves left to a position under the character E. Type the capital letter D and press the ENTER key to enter the correct data. You do not have to advance the cursor to the end of the line in order to enter the corrected version.

If you had typed this:

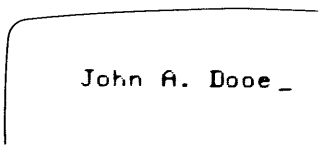

```
John A. Dooe _
```

press the  key until the cursor is under either letter o:

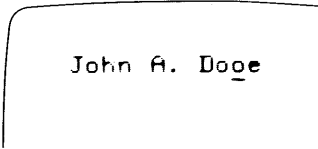

```
John A. Doge
```

press the DELETE key:

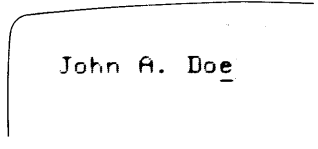

```
John A. Doe
```

When the line is correct, press the ENTER key.

Understanding Error Messages

Typographical errors made when entering a command are detected by the computer after you press the ENTER key. These errors result in a message being displayed on the screen. The error message appears on the screen directly below the line with the error immediately after the line is entered.

If the date is in the form:

MM/DD/YY

But you enter this line:

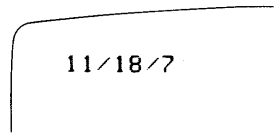

```
11/18/7
```

An error message similar to this is shown below the line:

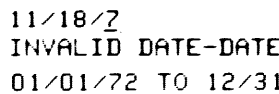

```
11/18/7  
INVALID DATE-DATE RANGE IS  
01/01/72 TO 12/31/99
```

Keyboard Operations

The cursor indicates the specific character in error. In this case, a two-digit number must be entered for the year.

When you have entered the appropriate number, the cursor indicates the next line is ready for entry.

You may at some time misspell a command. The `RUN` command, for example, must be spelled exactly as shown:

`RUN`

and followed by pressing the `ENTER` key in order for the current program in memory to be executed. If you had typed:

```
┌  
│  
│  R U I N  
│  
└
```

the computer would interpret `RUIN` as an illegal part of an expression:

```
┌  
│  
│  R U I N  
│  I M P R O P E R  E X P R E S S I O N  
│  
└
```

This is an example of a syntax error, which is an error in the structure of a statement or command. Syntax errors result most often from misspelling or misplaced punctuation.

Programming or software errors usually appear like this:



ERROR 31 IN LINE 90

This particular error message (Error 31) indicates that division by zero is being attempted in line 90 of the program you are running.

Error codes and their explanations are listed in the back of this manual. Procedures to follow if you encounter difficulties are described in Chapter 10.

CHAPTER 5

Storage Devices and Media

This chapter contains information on several HP storage devices and the associated media that you can use with your HP 250 system. They include:

- HP Integrated Storage Product (7908P, 7911P, 7912P)
- HP Built-in Flexible Disc Drive
- HP 7906 Disc Drive
- HP Built-in 5 Mb. Disc Drive

If you need information other than what is presented here, you should consult the operator guide which was sent with your storage device.

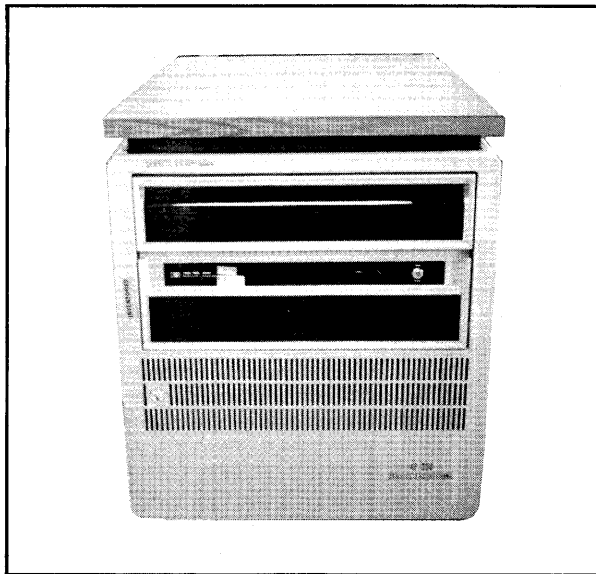

HP 7906 Disc Drive

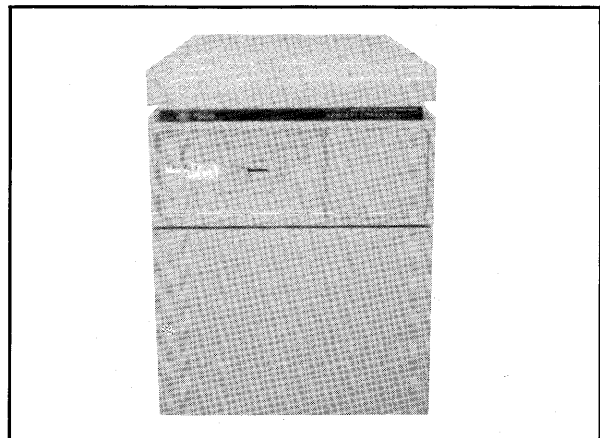

HP Integrated Storage Product



HP Built-in Flexible Disc Drive

HP Integrated Storage Product

An HP Integrated Storage product, as seen in the drawing below, consists of a disc drive, and a high-speed cartridge tape drive; the disc can be either an HP 7908, 7911, or 7912. A single "brain" (known as the controller) manages the operations of each disc and tape drive combination.

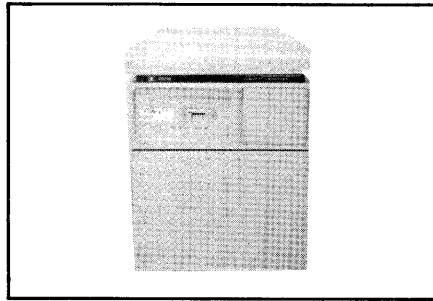

HP 7908, 7911, and 7912 Disc Drives

The only information you need to know regarding the HP 7908, 7911, and 7912 disc drives is power-on procedure. Once the drive is operating properly, you won't need to deal with it further. You never have to touch, insert, or remove the disc.

To turn any of the three discs on, push the switch located on the rear of the cabinet (see the drawing below) to the ON (1) position. To power off a drive, push the same switch to the OFF (0) position.

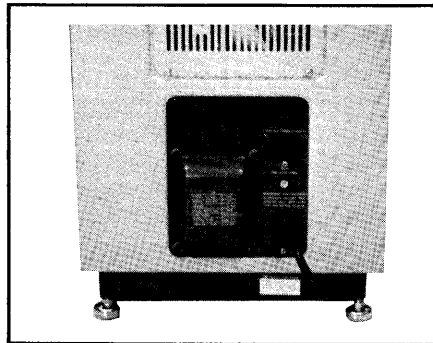

NOTE

You should never power off any Integrated Storage Product unless you are sure that no other tasks require it for processing.

Cartridge Tape Drive

The cartridge tape drive has been designed to serve as a backup device for the disc within the Integrated Storage Unit. It uses tape cartridges as the media on which information is recorded.

Tape Cartridges

Cartridge tapes come in two sizes. The short cartridge is 150 ft. long. The long cartridge is 600 ft. long and holds about four times more information than the short cartridge. You can differentiate one from the other by the length printed on the tape cartridge label.

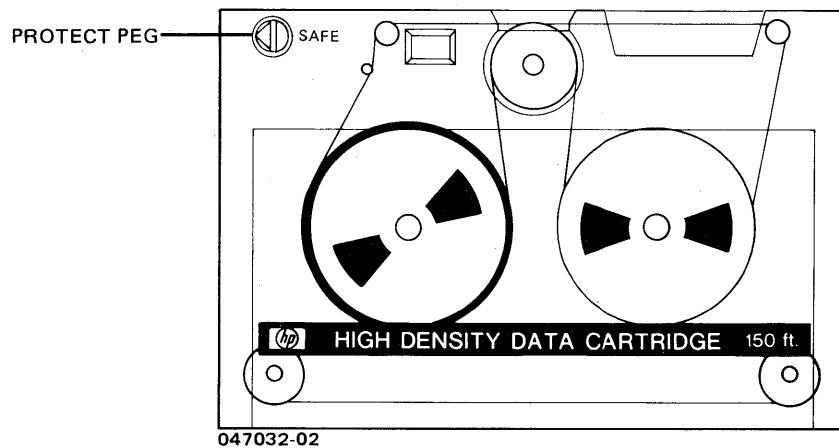

The peg in the upper left hand corner of the tape cartridge is used to keep information from being altered. Turn the peg to the SAFE position to protect the tape from any kind of writing or updating operation.

Handling Tape Cartridges

Follow these guidelines to ensure that your tape cartridges remain error-free for as long as possible.

- Do not touch the surface of the exposed tape.
- Do not attempt to clean the tape or tape guides within the cartridge.
- When not in use, remove all tape cartridges from the drive and store them in the protective plastic case.
- Do not store tape cartridges in excessively warm, dry, or humid areas, direct sunlight, or areas where magnetic fields are present (motors, transformers etc.)

NOTE

Although all HP 250 commands can work with the cartridge tape drive, use the drive only as a backup device. Any use other than copying files in a sequential manner will probably result in poor drive performance

Inserting a Tape Cartridge

If necessary, remove the tape cartridge already in the drive and store it in its case.

Slide the tape cartridge label-side up into the drive until you hear it click into its proper position (see drawing below).

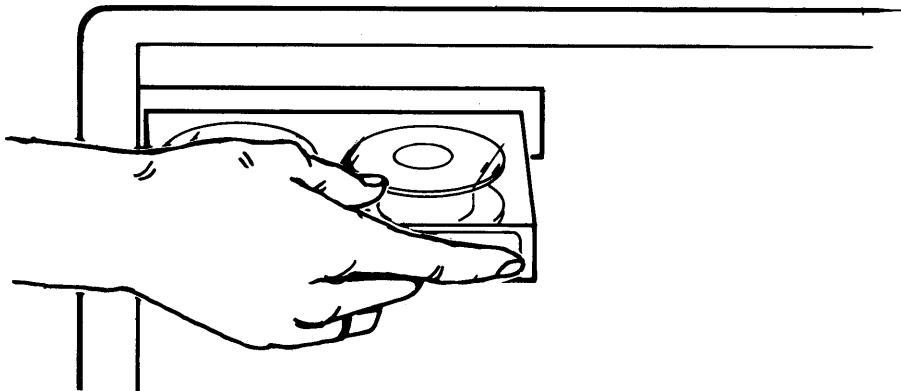

To keep the tape from becoming slack, the tape cartridge is always stored at the end-of-tape position. As a result, it must be rewound to the beginning-of-tape position to be available for use. This rewinding process may take anywhere from 30 seconds to two minutes depending on the length of the tape.

Using the Tape Drive

Once you have inserted the tape cartridge, and waited for it to be properly loaded, it is ready for use.

Remember that you will most likely be using the tape drive in conjunction with a backup or some other sequential operation. As a result, one error you might see is ERROR 54. This means that a duplicate file name exists. This can happen if you use the same tape cartridge continually to back up the same disc.

When the tape is being accessed, the eject lever is locked and the cartridge cannot be removed. The BUSY light comes on during any tape operation, including the loading and unloading process. The PROTECT light goes on when you insert a protected cartridge (SAFE peg in position).

You should note that most commands involving the tape drive will not execute unless its corresponding disc is ready (and functioning properly).

Removing a Tape Cartridge

To remove a tape cartridge from the drive, push the UNLOAD button on the front panel of the drive.

Part of the unloading process involves the drive automatically winding the tape to the end-of-tape position. This process, like the loading process, may take anywhere from 30 seconds to two minutes depending on the length of the tape.

When the UNLOAD button is pressed, the responsibility for the operation is assigned to the task which has been configured as TASKID 1 (your principal operator knows who this is). As a result, a program run under TASKID 1 may pause or the cursor may disappear from the workstation for up to two minutes while the tape is unloaded.

The BUSY light goes off and the drive buzzes to indicate that the winding process is complete. You may now remove the tape cartridge by sliding the eject lever to the right.

NOTE

Do not use excessive force on the tape eject lever. It will not operate when power is off or when the BUSY light is lit.

If a tape is removed from a drive under abnormal circumstances, such as the HP 250 experiencing a temporary power failure, you will get an error if you insert any tape other than the one you removed. You must re-insert the correct tape and complete the standard unloading process described earlier. If you cannot locate the correct tape cartridge, you must run a special utility program, which is described in the System Utilities Manual.

WARNING

The disc drive does not contain operator-serviceable parts. To prevent electrical shock, refer all installation and maintenance activities to service-trained personnel.

Flexible Disc Drive

Your HP 250 may be equipped with a flexible disc drive, located in the unit which houses the central processing unit. The drive is an assembly which rotates a disc, and then transfers information from the disc to memory (known as a read operation) or from memory to disc (a write operation).

The storage medium associated with this type of drive is the flexible disc (also known as a floppy disc, floppy, or diskette). It is a magnetic medium used to store data and programs; in addition, it is extremely for backup purposes and software data exchange.

Handling Flexible Discs

Follow these guidelines to ensure that your flexible discs remain error free for as long as possible.

- Always return discs to their storage envelopes after removing them from the drive.
- Since fingerprints on the disc can cause loss of data, handle the disc only by its label area.
- Never touch the surface of the disc showing through the protective sealed jacket.
- Never write on the protective jacket with a lead pencil or ballpoint pen. Use a soft felt-tip pen and write on the label only. Don't erase titles; instead apply a new label.
- Although the disc is flexible, don't bend or fold it since this, too, can cause damage to the disc.
- Never subject discs to temperature or humidity extremes.
- Contamination from dust, ashes, smoke, etc. can damage discs. Always close disc drive doors when not in use. Also close the roll-up door to cover all drives when not being used.
- Avoid placing discs in strong magnetic fields that may exist around transformers or magnets, since this can cause loss of data.
- Never remove discs from their sealed protective jackets.

- The inside surface of the sealed jacket is coated with a material that cleans the disc as it rotates. Any other method of cleaning may scratch the disc and cause loss of data.
- Use only HP approved discs - others may impair data integrity or damage the disc drive.

Inserting a Flexible Disc

Press the bar on the drive door to open the door. If necessary, remove the disc already in the drive and store it in its envelope.

Slide the new disc into the drive until you hear it click into its proper position. Insert the disc with the label up as shown:



Close disc drive door until it latches. Now that the disc is in place, you are ready to either load data from it or to initialize if blank. In some instances, another program may automatically access the disc.

Removing a Flexible Disc

Press the bar below the drive door to unlock the door. You can open the door only when the in use light is not on.

Slide the disc out and place it in its storage envelope. Be sure to close the disc drive door before resuming program operation. This will help keep the area free from dust and dirt.

NOTE

For a more in-depth description, read the booklet titled "Protecting, Preserving, and Replacing Your HP 250 Flexible Disc Media" (45251-90303).

The HP 7906 Disc Drive

The HP 7906 Disc Drive is a high-performance, random-access, mass-storage device. It has a fixed disc and provisions for accepting a removable disc cartridge.

Removable Disc Cartridges

Each HP 12940A Formatted Disc Cartridge is individually tested and certified to meet Hewlett-Packard's requirements for error-rate performance, mechanical balance, and surface flatness. Because of the unique interdependence of the disc drive and the disc cartridge, Hewlett-Packard's published specifications, disc drive performance, and reliability can only be assured when using the HP 12940A Disc Cartridge. For the above reasons, if the HP 7906 Disc Drive is operated using a disc cartridge other than the HP 12940A Disc Cartridge and damage occurs as a result, Hewlett-Packard will not be responsible for the repair or the resulting damage under warranty or under the service contract.

Storing Disc Cartridges

Special considerations must be taken for storage of disc cartridges. It is highly desirable for you to store disc cartridges in environmental surroundings that are nearly identical with those of the operating area. Storing disc cartridges in the same area where the disc drive is located avoids waiting for disc drive and disc cartridge temperature equalization.

Disc cartridges should always be stored in a clean, dust-free area and should not be stacked more than two high when lying flat. It is advisable to provide storage cabinets with shelves adjusted to the appropriate height. Disc cartridges should not come in contact with any magnetic material and should not be stored directly on top of the disc drive.

Using the HP 7906

You should observe the following precautions when operating the disc drive:

- Do not place magnetic media on top of the disc drive.
- Observe all warning and caution labels affixed to the disc drive.
- In normal operation the heads "fly" over the disc surfaces on a thin cushion of air. Dust or other contaminants between the head and the disc can cause the head to contact the disc and possibly damage the disc and/or head. Operate the disc drive in a clean area to minimize the chance of this malfunction occurring.
- If head and disc contact should occur as described above, do not attempt to retrieve data by placing the potentially damaged disc cartridge in another drive. Also, do not place another disc cartridge in this drive until the drive and disc cartridge have been checked by service-trained personnel.

WARNING

The disc drive does not contain operator-serviceable parts. To prevent electrical shock, refer all installation and maintenance activities to service-trained personnel.

The following paragraphs provide the basic operating procedures for the disc drive. Included is a procedure for startup, changing a disc cartridge, shutdown, and responding to disc drive faults.

Starting Up the HP 7906

To operate the HP7906, proceed as follows:

- 1) Set the RUN/STOP switch to the STOP position.
- 2) Push in on the bottom edge of the control panel access door to open it.
- 3) Set the POWER/OFF switch to POWER position and observe that the Unit Select Identification and DOOR UNLOCKED indicators light (Note that some HP 7906 models have the power switch on the rear panel).
- 4) Close the control panel access door.
- 5) Open the cartridge access door by pulling out and down on its recessed upper edge.

CAUTION

If head and disc contact should occur, as described earlier, do not attempt to retrieve data by placing a potentially damaged disc cartridge in another drive. Also, do not place another disc cartridge in this drive until the drive and disc cartridge have been checked by service-trained personnel.

- 6) Carefully insert an HP 12940A Formatted Disc Cartridge, access-door end first, until it is seated fully.
- 7) Close the cartridge access door.
- 8) Set the RUN/STOP switch to RUN. The DOOR UNLOCKED indicator will go out and after the startup sequence is complete (one minute or less), the DRIVE READY indicator will light. The DRIVE FAULT indicator will only light if a malfunction occurs.

Changing a Disc Cartridge

To change a disc cartridge, perform the following sequence:

- 1) If the disc drive is operating, set the RUN/STOP switch to STOP. The DRIVE READY indicator will go out immediately.
- 2) Allow the spindle to halt (30 seconds or less). The DOOR UNLOCKED indicator will light indicating that the cartridge access door may be opened.
- 3) Open the cartridge access door by pulling out and down on its recessed upper edge.
- 4) Firmly grasp the disc cartridge and slowly pull it straight out.
- 5) Carefully insert the new disc cartridge, access-door end first, until it is seated fully. Use only an HP 12940A Formatted Disc Cartridge.
- 6) Close the cartridge access door.
- 7) Set the RUN/STOP switch to RUN to resume operation.

Shutdown Procedure

To shut down the disc drive, proceed as follows:

- 1) Set the RUN/STOP switch to STOP. The DRIVE READY indicator will go out immediately.
- 2) Allow the spindle to halt (30 seconds or less). The DOOR UNLOCKED indicator will light indicating that the cartridge access door may be opened and the cartridge removed, if desired.
- 3) Push in on the bottom edge of the control panel access door to open it.
- 4) Set the POWER/OFF switch to the OFF position. The Unit Select Identification and DOOR UNLOCKED indicators will go out.

5 Mb. Disc Drive

Your HP 250 may include a built-in 5 megabyte disc and drive, located in the unit which houses the central processing unit. The drive is an assembly which rotates the disc, and then transfers information from the disc to memory (a read operation), or from memory to disc (a write operation). Information can be stored on the random-access surface of the fixed disc, allowing you to maintain data, even when the HP 250 is turned off.

A 5 Mb. Disc drive is powered on with the same key that powers on the HP 250. When the cursor appears on the screen, both the HP 250 and the 5 Mb. drive are ready for use.

CHAPTER 6

Printers

This chapter contains information on the three HP printers that could be connected to your HP 250 system. They include:

- HP 2631 Dot Matrix Printer
- HP 2608 Dot Matrix Printer
- HP 2601 Letter Quality Printer
- HP 2622D Thermal Printer

If you need information other than what is presented here, you should consult the operator guide which was sent with your printer.

HP 2631 Dot Matrix Printers

The HP 2631 Dot Matrix printer forms characters by printing a pattern of inked dots. The maximum speed of the HP 2631 printer is 180 characters per second. This printer uses fanfolded/pin-fed paper.

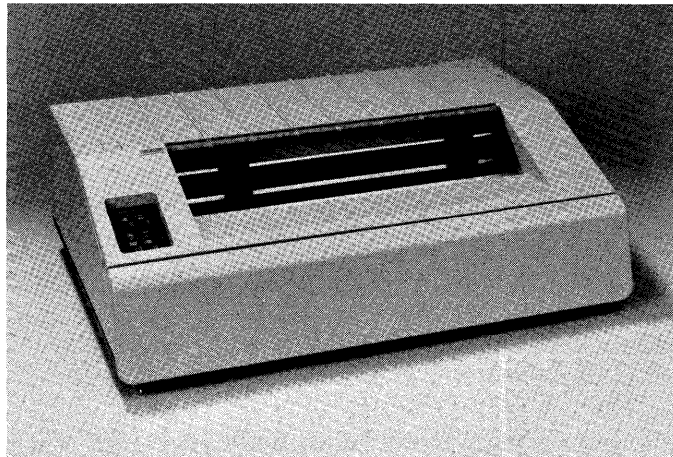

Loading Paper

Follow this procedure for loading paper into the dot matrix printer:

NOTE

If the printer runs out of paper while printing, it stops and beeps. Reload paper and press ON/OFF LINE button to continue printing with no loss of data

- 1) Take the printer offline by pressing the ON/OFF LINE button. Open the access cover, then open each tractor hold-down.

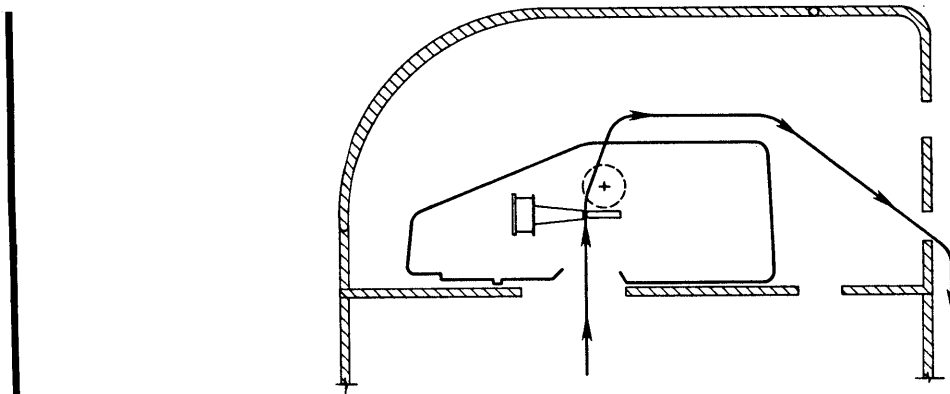

- 2) If your printer is on a stand, load forms through the bottom slot of the printer. If the printer is on a table, load paper through the back. Position the box of paper on the shelf or floor directly under the slot in the bottom of the printer.

- 3) Push the paper through the paper slot in the printer until it appears above the print mechanism. Engage the pin holes on the paper with the pin feeds on the paper tractor. Either tractor can be adjusted for width by lifting up on the tractor clamp and sliding the tractor to the desired position. Close the paper hold-down on each tractor.

CAUTION

Do not close the access cover with the paper hold-downs open since the tractor or the viewing window can be damaged.

- 4) Close the access cover. Be certain that the leading edge of the paper protrudes through the paper exit without binding.
- 5) Press the FORM FEED switch to advance paper to the next Top of Form position.

NOTE

Pressing the RESET button sets the printer to Top of Form at its current position (without advancing the paper). Since other printer conditions can be affected by RESET, refer to your HP 2631 operator manual for details.

- 6) Use the paper advance knob to move paper to the Top of Form. For fine adjustment, pull the paper advance knob out while turning. Put the printer back on line by pressing the ON/OFF LINE button.

Replacing Ribbon Cartridges

In order to remove the ribbon cartridge and replace it with a new one, follow the procedure below.

CAUTION

If the printer has been in operation for more than five minutes, the print head will be hot. Before installing or changing the ribbon, turn the printer off and allow it to stand with the access cover open for at least 15 minutes.

Removal

- 1) Take the printer offline by pressing the ON/OFF LINE button.
- 2) Remove the old ribbon cartridge by raising the right hand end up, then lift and discard it.
- 3) Clean and vacuum all paper, dust, and residue from the area under the ribbon cartridge.

Installation

- 1) Be sure the printer is switched offline.
- 2) Install the ribbon cartridge by sliding the groove in the left end of the cartridge over the tongue on the left mounting bracket.
- 3) Thread the ribbon around the left ribbon guide and in front of the print head. Drop the right side of the cartridge onto the drive shaft. Use the knob on the top right of the ribbon assembly to tighten and align the ribbon.

Cleaning the Print Head

The print head should be removed and cleaned at least once every two months. If you notice a deterioration of print quality, you may need to do more frequent cleaning. Follow the procedure in your HP 2631 Operator's Manual.

HP 2608A Printer

The HP 2608 Dot Matrix Printer forms characters by printing a pattern of inked dots. The maximum speed of the HP 2608 is 400 lines per minute.

Operator Safety

Close the access cover when the printer is in a ready-to-operate condition and when it is operating. Keep hands, long hair, necklaces and articles of clothing such as long sleeves out of the printer when ready-to-operate or operating conditions exist.

Loading and Adjusting Paper

The HP 2608A will accommodate continuous fan-fold edge-perforated paper. It will accommodate forms thickness variations up to a total pack thickness of 0.61 mm (0.025 inches). Forms thicker than 0.61 mm should be tested to verify that they will print successfully. Recommended paper weights are: 15 to 20 pounds single part and 11 pounds multi-part forms. Forms and card stock should be tried for satisfactory feeding, registration, and print quality. Multi-part forms must be held together without the use of metal or plastic fasteners.

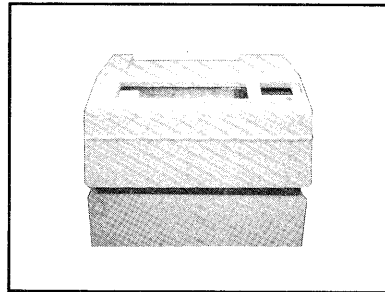

Paper is loaded through the bottom of the HP 2608A. To load it, perform the following sequence of steps:

- 1) Position the paper supply inside the printer stand against left side alignment bracket.
- 2) Pull the platen release lever toward you to open the platen.
- 3) Open the access cover; then open both tractors. If a different form or horizontal position is required, unclamp both tractors so they may be adjusted to a different width. The tractors should be positioned so that paper may be pushed up into the printer without hitting the open tractor doors.

NOTE

An interlock prevents printing when the platen is open. A fault indication is displayed on the control panel by the PLATEN/RIBBON Fault Indicator during paper loading and adjustment.

- 4) Push the paper up into the printer from below until it appears above the print mechanism; then pull the paper up until the holes can be matched to the tractor lugs. Make certain the paper is not skewed to either side. Close the tractors. Push the platen release lever to close the platen. If the forms thickness has been changed, use the Platen Adjust Knob to adjust the gap for maximum print quality.
- 5) Clamp the tractors in place on the tractor guide shaft if previously released.
- 6) When the printer runs out of paper, it stops at Top Of Form. It is only necessary to use the FORM FEED switch to advance the printer to the Top Of Form position if paper out did not occur.

NOTE

Pressing the RESET switch will clear all pre-established or programmatically controlled conditions of the printer to power-on status. Therefore, it is recommended that the RESET switch not be used to define Top of Form.

- 7) One of two methods may be used to move the paper to the desired Top Of Form position as explained in the following paragraphs:

Use the LINE FEED switch to advance the paper one line at a time and align the horizontal paper perforation with the desired form length on the scale (8-inch through 12-inch) which is located on the top of the printer. For example, if you want to print on an 11-inch form, advance the form until the desired first print position is aligned with the 11-inch mark on the scale. Use of the LINE FEED switch does not change logical Top of Form when paper out has occurred.

or

For more exact adjustment of the paper, use the plastic Top Of Form adjustment scale which is supplied with the printer. This scale provides precise adjustment for forms from one to 12 inches in length.

Open the left paper tractor. Align the desired form length (form length is indicated on the left edge of the scale) with the horizontal paper perforation and match the holes in the adjustment scale to the tractor lugs. Close the paper tractor.

Use the LINE FEED switch or the UP/DOWN forms adjust switches to align the desired measurement increment (located on the right edge of the scale) with the v-notch on the left paper tractor. For example, if you want the first line of print to be one inch from the perforation on an 11-inch form, align the one inch measurement on the right side of the scale with the v-notch on the left paper tractor.

Use the UP and DOWN Forms Adjust switches to make the final fine adjustment for locating the first line of print. The UP switch advances paper one dot row at a time. If the switch is held down, paper will continue to advance. The DOWN switch retracts paper; however, if the platen is not open, you must tension the paper below the printer (or release the platen) to allow it to move in the reverse direction. Use of these Forms Adjust switches never changes logical Top Of Form. Final forms adjustment must be made by moving the paper upward with the platen closed to ensure proper tensioning of the paper.

- 8) A horizontal scale located on the top of the core bar provides column locations for each of the 132 print columns. Horizontal adjustments may be made by unclamping both tractors and moving both tractors and paper to the desired position.
- 9) Close the access cover. Be certain that the leading edge of the paper protrudes through the paper exit without binding.
- 10) Logical Top Of Form is defined as the present paper position when the printer is put on-line after a paper-out condition has occurred.
- 11) To remove paper, tear below the machine (inside the stand) and operate the FORM FEED switch until all paper is clear of the machine.

CAUTION

Do not pull paper down through the printer; perforations may catch and damage the ribbon shield or paper out switches.

Replacing Ribbon Cartridges

Tools are not required to install or remove the ribbon cartridge.

NOTE

An interlock prevents printing when either ribbon cartridge is removed or the platen is open. A fault indication will be displayed on the control panel by the PLATEN/RIBBON indicator during ribbon removal and installation.

Removal

- 1) Pull the platen release lever toward you to open the platen.
- 2) Lift the back side of the ribbon cartridge until you have removed it from the drive shaft and the mounting slot in the metal base.
- 3) Discard the used ribbon cartridge.
- 4) Close the platen and clean any paper, dust or residue from the area under the ribbon cartridge.

Installation

- 1) Pull the platen release lever toward you to open the platen.
- 2) Slide the ribbon into place between the print mechanism and the metal ribbon shield, as shown in the sketch.
- 3) Fit the mounting lug on the lower left underside of the ribbon cartridge into the mounting slot on the metal base. Note the small knob on the top surface of the cartridge for moving the ribbon manually. Use this knob to take up any slack in the exposed portion of the ribbon and to make sure the ribbon is tight and straight.
- 4) Make certain the cartridge is secured on both the left and right ends, and that the ribbon is completely positioned in front of the print mechanism.
- 5) Close the platen.

HP 2601 Letter Quality Printer

The HP 2601 printer is a daisywheel printer that produces typewriter-quality output. It uses either plastic or metalized print wheels, which are available in several languages.

Loading Paper or Forms

Inserting paper or forms into the HP 2601 is accomplished in much the same manner as in a standard typewriter. Paper is inserted down behind the metal paper out bail and platen while the platen is turned manually to bring the paper around and up in front of the platen. The front paper bail aids in guiding the paper back over the platen to the rear when pulled forward. The paper release lever at the right-hand side of the printer may be pulled forward to release roller pressure after paper insertion so the paper can be properly aligned in the printer. After positioning the paper, return both the front paper bail and paper release lever to their operating positions.

Paper Thickness/Print Intensity Adjustment

The 2-position multicopy lever located at the front of the carriage assembly adjusts for paper thickness and print intensity. Setting the lever to its upper position moves the carriage close to the platen, and actuates a switch for the proper setting of light and medium weight paper and form sets of up to two carbon copies. For heavier or form sets of up to five copies, the Multicopy lever is set to its lower position. This rocks the carriage away from the platen slightly, and deactivates the switch, enabling increased print intensity.

To avoid the possibility of ribbon damage, the Multicopy lever should always be set to its upper position when printing on single sheets of paper using carbon ribbons.

Installing a Print Wheel

CAUTION

Ensure that the power to the HP 2601 is turned off before installing a print wheel.

- 1) Grasp the print hammer guide and pull it toward you to tilt the print wheel mechanism away from the platen and card guide.
- 2) Rotate the print wheel motor hub to bring the hub's alignment tab to the upper part of its arc of travel.
- 3) Grasp the print wheel (metal or plastic) by its rubber hub and place it on the print wheel motor hub. Align the wheel's alignment slot with the hub's alignment tab, and push the wheel firmly to fully seat it onto the motor hub.
- 4) Tilt the print wheel mechanism back rearward into its operating position.
- 5) Ensure that the print wheel select rotary switch on the inside control panel matches the type of print wheel selected.

Removal of the print wheel is simple. Tilt the print wheel mechanism toward you, grasp the print wheel by its rubber hub and pull it free of the print wheel hub.

NOTE

Print wheels are rugged and dependable, but they can be damaged. Use care when handling them to avoid bending the petals. Always store them in their plastic containers when they are not installed in the printer. When installing a metal print wheel to be used with a cloth ribbon, make sure the print wheel is clean.

Replacing a Ribbon Cartridge

CAUTION

Ensure that power to the HP 2601 is turned OFF (initial start only).

- 1) Open the plastic envelope and remove the ribbon cartridge. Note the small knob on the top surface of the cartridge for moving the ribbon manually. Use this knob to take up any slack in the exposed portion of the ribbon and to make sure the ribbon is tight and straight.
- 2) Hold the cartridge in one hand with the exposed ribbon toward the platen as shown. Lower the cartridge down over the print hammer guide. Engage the ribbon behind the two ribbon guide posts and push the cartridge "ears" against the card guide. Check that the exposed ribbon is straight, and located between the card guide and print wheel. Push the cartridge down firmly until both latches have snapped into position locking the cartridge on the carriage ribbon platform. Rock the cartridge back and forth on the platform to ensure that the ribbon is free to move up and down. Turn the manual ribbon advance knob to ensure that the ribbon is tight, straight and ready to operate.

You remove the ribbon cartridge by pressing down on both latches simultaneously. Raise the cartridge slightly, grasping it gently, and lift it out of the printer.

- 3) When a ribbon cartridge is nearly empty, a yellow cross-hatched pattern will appear on the visible back side of the ribbon.

The HP 2601 will stop printing, sound its alarm and light the RIBBON/PAPER lamp if printing is attempted with the ribbon in the warning (yellow) zone.

NOTE

When installing a cloth ribbon to be used with a print wheel make sure the print wheel is clean. See the section with cleaning instructions.

Cleaning Print Wheels

Print Wheels used with carbon ribbons seldom need cleaning. Plastic Print Wheels used with cloth ribbons require an occasional cleaning. A Metal Print Wheel requires periodic cleaning when used with a cloth ribbon. Consult the operating manual sent with the printer for procedures on cleaning the print wheel.

Changing Ribbons During Operation

As mentioned earlier, the HP 2601 will stop printing, light the RIBBON/PAPER light, and sound the alarm upon reaching the end of a carbon ribbon. Should this happen while receiving data from the system, you should open the access cover, replace the ribbon cartridge as described, close the access cover, and then touch the Control Panel RESET switch to resume printing.

NOTE

You should ensure the ribbon is tensioned and in the position (up or down) last commanded by the host prior to resuming system operation.

Cleaning the Print Hammer

Consult the operating manual sent with the printer for procedures on cleaning the print hammer.

HP 2622D Thermal Printer

The optional thermal printer uses specially manufactured paper. It is recommended that you always use HP Thermal Paper in your printer. Use of non-HP paper can shorten the life of the print head and also affect print quality. Additionally, if you have an HP Warranty Service Contract, you must use HP Thermal Paper to maintain a valid contract.

Loading Thermal Printer Paper

To load a roll of thermal paper, perform the following steps:

- 1) Lift the top cover of the printer mechanism. An illustration of the correct paper position and flow is embossed on the underside of the cover.
- 2) Press the latch toward the front of the unit to release the latching frame. Lift the hinged latching frame to its forward position.
- 3) Remove any paper remaining in the printer.
- 4) The center paper core is held in place by a metal rod inserted through the center of the core. Grasp the core and lift forward and upward along the guide slots to remove the core and rod.

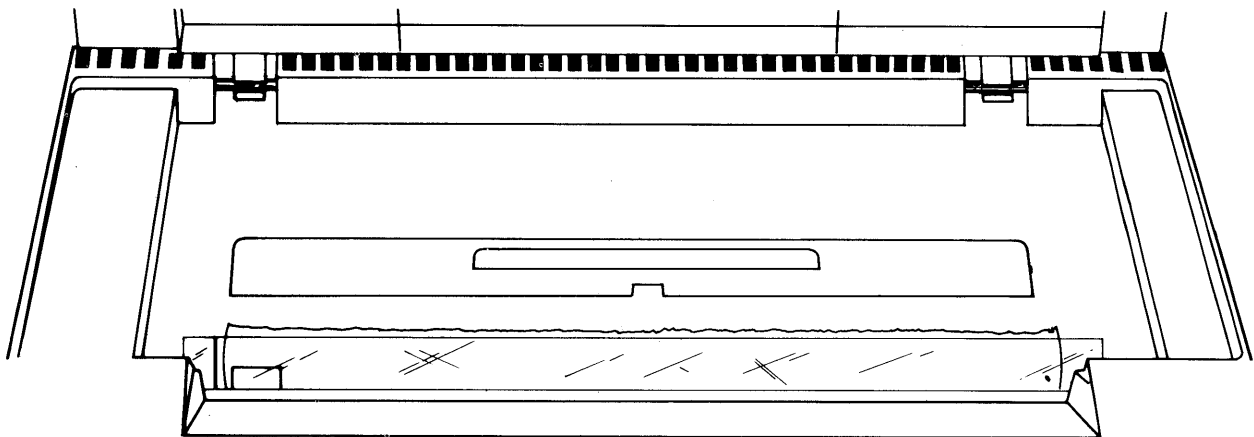

- 5) Remove the old core from the rod and insert the rod through the core of a new roll of paper.
- 6) HP Thermal Paper is coated with print material on only one side; it must be inserted correctly into the printer to produce a print image. The paper must feed toward the front of the unit from the underside of the paper roll.
- 7) Place the ends of the metal rod into the guide slots and press downward and then toward the back of the unit until the rod snaps into place.
- 8) Feed the leading edge of the paper through the latching frame and the clear plastic guide window.

CAUTION

The print head is relatively fragile and susceptible to damage; be careful not to strike it while loading paper.

- 9) Lower the latching frame without locking it into place.
- 10) Align the sides of the paper with the guide lines embossed on each side of the guide window.
- 11) Each new roll of HP thermal paper has a glue spot near the leading edge of the roll that holds the paper roll intact during shipment. You must not allow the print head to come in contact with this glue spot. Feed approximately 12 inches of paper through the latching frame so that the glue spot is beyond the print head and guide window.
- 12) Press the latch down until it clicks into place. If the latch is not locked, a printer error will be printed at the bottom of the screen whenever you attempt a print operation.
- 13) Tear off the excess paper using the guide window as the cutting edge.
- 14) Close the top cover securely and then press the ENTER key.

NOTE

If subsequent printer operations produce no image on the paper, you probably installed it with the wrong side facing the print head.

CHAPTER 7

Graphics Devices

Graphics Plotters

A Graphics Plotter allows you to draw pictures on your computer system, like these:

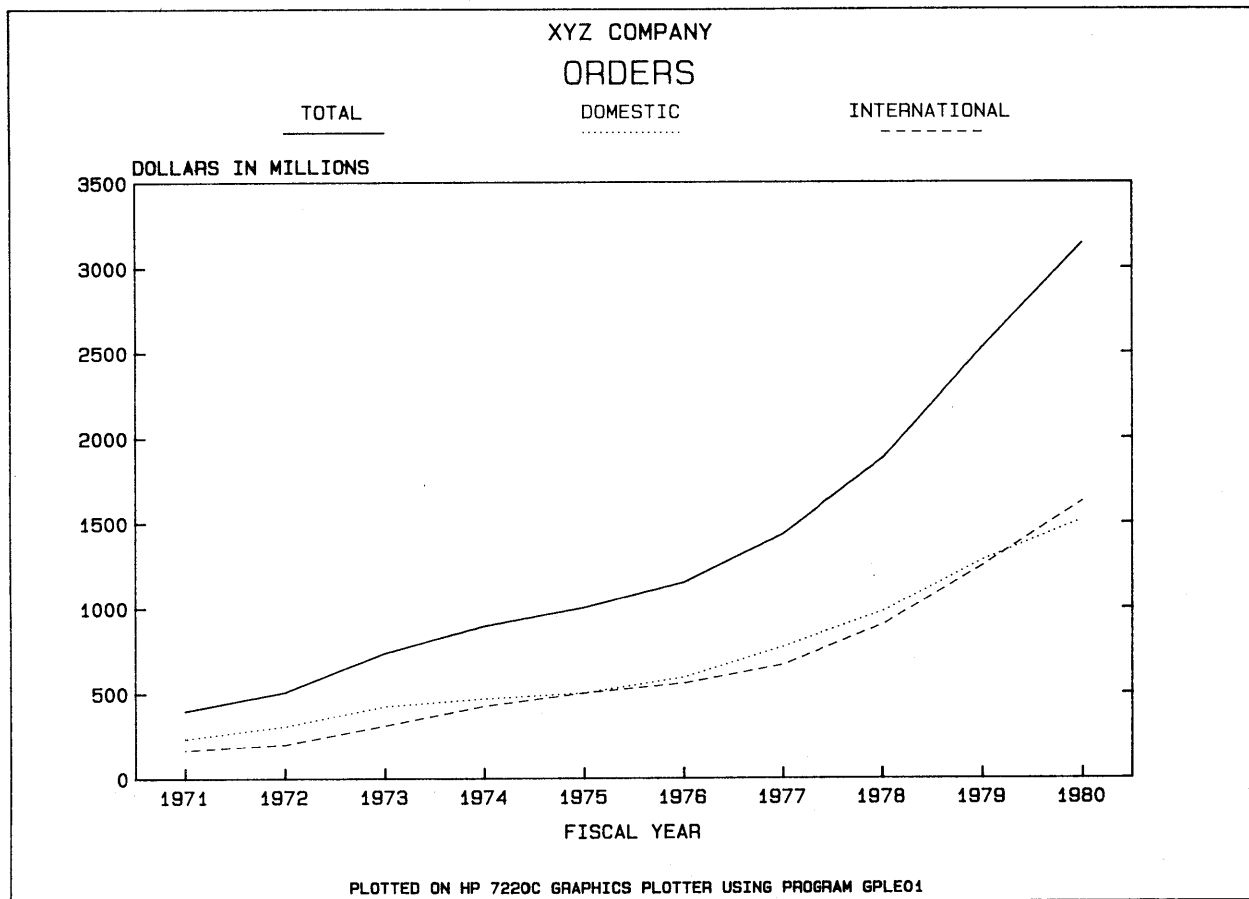

In order to draw these pictures, you need your application program, and your graphics plotter must be connected to your computer system.

Graphics Devices

Your plotter is likely to be a single pen plotter like this .

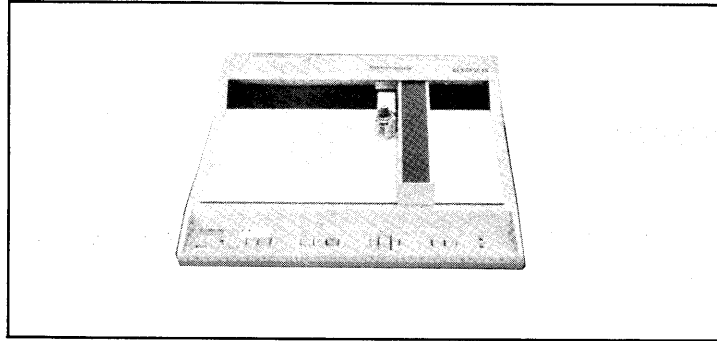

or an eight pen plotter, like this. .

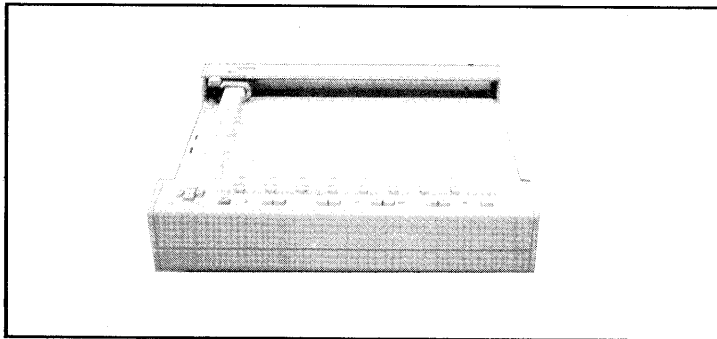

or an eight pen plotter with automatic chart advance, like this...

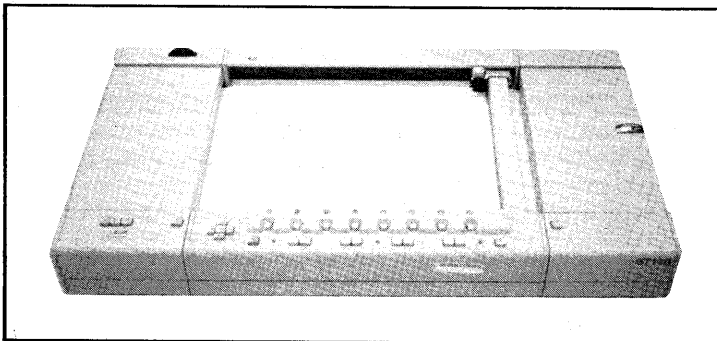

These plotters differ mainly in the maximum paper size, number of pens, type of paper, and automatic paper advance capability.

In this chapter, you will learn how to operate an HP Graphics Plotter.

The instructions from this chapter are a simplified version of those available from the Operating and Programming Manuals supplied with HP Graphics Plotters. More details and pictures may be found in the manual supplied with your plotter.

To proceed further, you should have one of the following plotters connected to your system:

Single Pen Plotter

HP 7225A/7225B Graphics Plotter with either
option 17603A RS-232-C Personality Module
or
option 17604A RS-232-C Personality Module

Four Pen Plotter

HP 7220A/7221A/7221B Graphics Plotter

HP 7220S/7221S Graphics Plotter
with automatic paper advance

Eight Pen Plotter

HP 7220C/7221C Graphics Plotter

HP 7220T/7221T Graphics Plotter
with automatic paper advance

Turning on AC Power

If the device has never been connected to your power line, be sure it is properly configured for your type of AC Power BEFORE plugging it in. See the plotter Operating and Programming Manual for details.

1. Locate the Power Switch

Single Pen Plotters - Located on the right hand side near the base of the plotter.

Four and Eight Pen Plotters - Located under the right front edge near the base.

2. Turn on the Power

Push the switch until it stays in the depressed position. To later turn off the power, just push again to release from the depressed position.

Noticeable things should happen; the sequence depends on the particular plotter.

Single Pen Plotters

1. The LINE lamp goes on steadily.
2. The OUT OF LIMIT light momentarily flashes on.
3. The pen holder moves to the lower right corner.
4. Any paper that was on the plotter will now be held down by electrostatic force.

Four and Eight Pen Plotters

1. The pen holder moves to the lower right corner.
2. The ON LINE light turns on steadily.
3. The OUT OF LIMIT light turns on steadily.
4. Any paper that was on the plotter will now be held down by electrostatic force.

Now you are ready to add or change pens and/or paper.

Loading Pens and Paper

Pens and paper may be loaded before starting your application program and changed while running the program.

NOTE

For safety reasons, the plotter should be disabled from receiving any data from the computer whenever pens or paper are changed.

Disabling the Plotter

To disable the plotter:

SINGLE PEN PLOTTERS - Carefully push the CHART LOAD pushbutton so that the RESET button is not pushed. The CHART LOAD lamp will go on and the plotter will be disabled from receiving any data from the computer. First change the pens and then the paper, turning off the CHART LOAD lamp as the last operation. If you choose to smooth down the paper after turning off the CHART LOAD lamp, do it at your own risk after making sure that no system user is sending data to your plotter. If your application program is running, it will supply some safeguards.

FOUR and EIGHT PEN PLOTTERS - Push the STBY (STANDBY) switch to cause the standby lamp to go on steadily. You should do this only when plotting has stopped because any data in the plotter will be purged by this operation. With the STANDBY lamp on, you may change pens and paper safely in any order. When ready to resume plotting, push the ON LINE button twice to cause the lamp to blink steadily and check that the CHART LOAD lamp is off.

Changing Pens

HP offers a variety of pens including narrow tip (0.3 mm) and wide tip (0.6 mm or 0.7 mm) pens for paper and overhead transparency film in a variety of colors.

The most commonly used pens are the narrow line (0.3 mm) paper pens in black, red, green, and blue colors; you should ensure that a supply of these pens are kept in stock.

The procedure for loading and changing pens differs for the single pen and multiple pen plotters. In both cases the plotter should be disabled as explained above before performing the operation.

Single Pen Plotters:

1. Disable the plotter by turning on the CHART LOAD lamp.
2. Pull out the old pen with one hand while holding the metal carrier ring with the other hand.

Graphics Devices

3. Press the new pen into the holder while still holding the carrier ring with the other hand. See the illustration below.
4. Re-enable the plotter by turning off the CHART LOAD lamp. You should put a cap on the pen after the plotting session is terminated.

Four and Eight Pen Plotters:

1. Disable the plotter by turning on the STANDBY lamp.
2. Push the PEN SELECT pushbutton for the stall to be loaded. The old pen will be placed in the pen holder.
3. Remove the old pen from the pen holder.
4. Load the new pen into the pen holder, as shown in the figure below.
5. Push the ENTER and appropriate PEN SELECT (1-8) push-buttons in sequence. The pen will be loaded into the selected stall.
6. Repeat the operation for any other pens to be changed.
7. It is recommended that stalls 1 through 4 be loaded with narrow line paper pens, black, red, green, and blue, respectively.
8. Set the ON LINE lamp to the blinking state when ready to continue plotting. The STANDBY lamp should turn off automatically.
9. After finishing plotting, be sure that all pens are in the stalls. If one remains in the pen holder, it may dry out. To return it to the holder, push ENTER and the appropriate PEN SELECT (1-8) pushbutton.

Changing Sheet Paper

All of the HP Graphics Plotters are capable of plotting on smooth surface sheets of paper, smooth so that the ink does not bleed. HP supplies a broad range of such paper, and others may be used.

Common paper sizes that are used include:

ISO A4 - 210 mm x 297 mm

ISO A3 - 297 mm x 420 mm

English A - 8.5 in. x 11 in.

English B - 11 in. x 17 in.

Most plotting is done with ISO A4 or English A sizes. The following procedures are given for these smaller size sheets. Similar procedures are used for large size sheets on 7220 and 7221 plotters.

Single Pen Plotters:

1. Push the CHART LOAD pushbutton to turn on the CHART LOAD lamp. This both disables the plotter from the computer and turns off the electrostatic paper hold.
2. Remove old sheet of paper.
3. Place a new sheet down on the surface. If the sheet has binder holes along a long edge, PLACE THE HOLES TOWARDS THE BACK OF THE PLOTTER, away from the front panel controls.
4. Smooth out the paper with the back of your hand.
5. Push the CHART LOAD lamp to turn off the lamp.

NOTE

The plotter RESET button is adjacent to the CHART LOAD button. If this is accidentally touched while running the application program, valuable data may be lost. In addition, care must be used if you smooth out the paper with the CHART LOAD lamp off. The single pen HP Graphic Plotters do not have any other convenient way to be disabled from the computer. Usually, your application program will provide safeguards. If so, paper should be changed only after starting the application program.

Four and Eight Pen Plotters:

1. Disable the plotter by turning on the STANDBY lamp.
2. Push the CHART LOAD pushbutton to turn on the CHART LOAD lamp. The OUT OF LIMIT light should also go on steadily, and the pen holder is moved to the upper right corner of the platen.
3. Remove old paper.
4. Place sheet of paper on the platen so that the lower edge is under the lips of the nylon paper stop. Then move the paper to the left so that the paper is snug against the left paper stop. (The left paper stop may be depressed. If so, raise the lower one by pushing with a pencil on the upper one.) See the figure below. For smaller sheets of paper (e.g., ISO A4), place the long edge of the paper against the left edge of the plotter.
5. Press the CHART HOLD pushbutton and smooth out any ripples using the back of your hand with left-to-right motion. The CHART LOAD lamp should go off.
6. When ready to resume plotting, push the ON LINE pushbutton twice. The ON LINE lamp should blink, and the STANDBY lamp should turn off.

Changing Roll Paper

The S and T plotter models have automatic chart advance capability. You may use these plotters either with a roll of paper or in the single sheet mode used with the other plotters. See the Operating and Programming Manual supplied with your plotter for detailed instructions on changing a roll of paper.

Loading Overhead Transparency Materials

The HP 17055A Overhead Transparency Kit may be used with HP Graphics Plotters to produce colorful, professional appearing transparencies for presentation.

The kit comes with 200 sheets of special overhead transparency film and a supply of pens in 7 colors and two line widths. Additional pens and film may be ordered separately.

Special procedures must be used in handling the pens and film, as described in the following sections.

Transparency Film Pens

The transparency film pens have a special fast drying ink for transparency film. The transparency film pens come in two line widths, which may be identified by markings on the top of the pen body. In addition, the pens come in many compatible colors.

Because of the fast drying tendency of the inks in the pens, the pens should be capped when not in use.

A pen should be checked after a period of storage by gently drawing a warm-up line on a scrap piece of film before placing the pen in the holder. Do not use pressure or the pen tip may be damaged.

A dry pen can sometimes be restored by dipping the tip in the special solvent supplied with the HP 17055A Overhead Transparency Kit. It may take several minutes before the dry seal dissolves. Try writing a line on a scrap piece of film. Repeat as needed.

For multi-pen plotters, you may wish to remove leftover ink from the boots in the pen stalls using a cotton swab and solvent. This will prevent the transfer of other inks to the plots.

The solvent may also be used to clean the transparency film ink from the hands, plotter surface, or transparencies.

It is recommended that paper pens be left in the plotter after finishing your application if the plotter is being used for both paper and transparency film applications.

Transparency Film

The transparency film surface must be completely free of fingerprints and dust for the ink to adhere properly. Always handle with the tissue covering the writing surface.

Leave the tissue on the film while placing it on the plotter. Engage the electrostatic chart hold by turning off the CHART LOAD lamp. Then smooth down the film with the back of your hand rubbing across the tissue. Finally, carefully remove the tissue.

The ink dries on the transparency film in about 10 minutes at 20-30 degrees C (68-86 degrees F). It will dry faster at temperatures up to 55 degrees C (131 degrees F), slower at lower temperatures to 10 degrees C (50 degrees F). Until dry, nothing should be placed on the transparency material. You may carefully remove it from the plotter while still wet, holding it by the edges and placing it in a safe place.

Always store the dry transparencies in a cool, dry place with tissue between sheets of film or enclosed in a plastic cover.

Limitation of Some Early HP 7225A Models

An application program can instruct the plotter to slow down the maximum plotting speed for transparency film applications. This allows better ink transfer from the pen to the transparency film.

Some early models of the HP 7225A Graphics Plotter do not have programmable pen velocity control. For those models, the pen will travel faster than desired for long lines, and you must be especially careful to use clean transparency film and fresh pens as often as possible.

Routine Maintenance

Maintenance of the plotter is limited to a periodic cleaning of the external surfaces, electrostatic paper hold-down surface, and air filter.

WARNING

Disconnect the plotter from the power source prior to performing any maintenance. When cleaning, apply water using a lint-free tissue. DO NOT allow water to run onto the electrical components and circuits or through openings in the enclosure as it may create a shock hazard. Scratches or punctures in the electrostatic paper hold-down surface may expose high voltage conductors. Plotters damaged in this manner should not be operated.

Electrostatic Paper Hold-Down Surface Cleaning

Dust and other contaminants will lower the paper holding capability. Although pen ink will not affect hold-down performance, it may be desirable to remove ink stains as well.

Cleaning moderate contamination can be accomplished as follows:

1. Prepare a mixture of 50% isopropyl alcohol and 50% water by volume.
2. Apply the alcohol/water mixture to the surface using a lint-free tissue. Immediately wipe any moisture from the surface. Never let any liquid stand on the surface as it may become permanently damaged.

If the surface cannot be easily cleaned with the alcohol/water mixture, cleaning can be accomplished as follows:

1. Select a clean, lint-free cloth that will not scratch the surface.
2. Remove transparency ink with solvent (HP 5060-6828) and dry thoroughly before continuing the cleaning process.

3. Dampen the cloth with warm water or alcohol and apply a light amount of powdered cleanser.
4. Wipe the surface until it is clean, then rinse the cloth and wipe any remaining cleanser from the surface. Immediately wipe any moisture from the surface. Alcohol and water may be used to remove the remaining cleanser from the surface.

Air Filter Cleaning

The air filter (located on the left side for single pen plotters and on the rear panel for multi-pen plotters) should be cleaned approximately every three months or when dirt becomes visible on the filter surface, whichever happens first. Remove the filter and either hold it under running water, or wash it in warm soapy water, followed by a rinse in clean water. Dry the filter thoroughly before replacing it.

In Case of Trouble

If the plotter does not seem to be operating correctly, perform the following sequence of steps:

1. Check to see the plotter is plugged in, powered on, and cabled properly.
2. Have your principal operator run the CONFIG program to ensure that your HP 250 is configured to use the plotter.
3. Run the plotter test program described in the chapter titled "In Case of Difficulty".

CHAPTER 8

System Commands

You use system commands to execute programs, clear memory, store or retrieve files, delete files, copy files, and output information.

All mass storage operations deal with files, which are the basic component of a storage medium.

When you turn your HP 250 system on, the device used to load the operating system is automatically specified as the default mass storage device, unless another device is specified in the CONFIG program. This is the device to which all file operations are directed if no other device is specified.

REMINDER

Although all commands can be used with a cartridge tape drive, it is not intended to be used as a disc. Any use other than copying files in a sequential fashion will probably lead to poor performance and early drive failure.

Accessing Files on Storage Devices

Wherever a file name is used in a system command, a unit specifier or a volume name can be included. The unit specifier is the physical location of the file (a cartridge tape, hard disc, flexible disc) while the volume name is a name that you assign to a storage medium with the PRINT LABEL command.

The following is analogous to accessing files on your HP 250 system. Suppose you asked a friend to come to your home. Once this friend arrives at your street, there are several ways he can locate your home. One way could be that the friend is aware that your name is painted on your mailbox; he can look at every mailbox until he finds the right name. Another way could be that you told the friend your street address; with this piece of information, your friend can locate your home easily.

Accessing mass storage devices is very similar to this. You can access a file on any particular storage device by knowing either the label of the storage medium (the volume name) or by knowing the physical address of the storage device (the unit specifier).

Assigning Names to Storage Media (PRINT LABEL)

You assign names to storage media with the PRINT LABEL command. For example, if you wanted to have the label SAMPLE on the volume in the default mass storage device, you would enter:

```
PRINT LABEL "SAMPLE"
```

The label you give to a volume cannot exceed 8 alphanumeric characters, the first of which cannot be a number.

If you do not know the label on the default mass storage device, but wish to find out, enter the following command:

```
READ LABEL A*
```

Physical Addresses

Each storage device is assigned an address by which you can access the files located on the medium that is currently located in the drive.

For example if you want to print the label SAMPLE on a tape cartridge (which is not the default mass storage device), you enter the following command:

```
PRINT LABEL "SAMPLE" ON ":K"
```

The ":K" specifies the physical address (the unit specifier) of the tape.

If you wanted to determine the label on a tape currently in the tape drive (and the tape drive is not currently the default device), you enter the following command:

```
READ LABEL A* ON ":K"
```

A list of all physical unit specifiers appear in Appendix C.

Once you understand this concept of accessing discs and files through either physical addresses or volume names, you will have no trouble using the commands presented in this chapter.

Changing the Default Mass Storage Device (MSI)

As described earlier, the device that is used to load the operating system is automatically specified as the default mass storage device. You can change the default device by executing the MASS STORAGE IS (or MSI) command.

For example, if you want to declare the tape drive as the default mass storage device, enter the following command:

```
MSI ":K"
```

If you want to declare the volume whose label is SAMPLE as the mass storage device, enter the following:

```
MSI",SAMPLE"
```

Executing Programs (RUN)

To load and run a program that is not currently in memory, you use the RUN command. For example, if TAX is the name of a program to be loaded, the command:

```
RUN "TAX"
```

causes TAX to be loaded into memory from the default mass storage device and then run.

If any program already exists in memory, then the command

```
RUN
```

causes that program to be run.

Erasing the Contents of Memory (SCRATCH)

All or part of your user work area can be erased by using the SCRATCH command .

SCRATCH	Erases programs and variables
SCRATCHA	Erases the entire user area (same as CONTROL HALT)
SCRATCHP	Erases programs, variables, and binary routines.
SCRATCH KEY#	Erases softkey typing-aid definitions.

File Operations

You can store data and programs on various mass storage media for later use. All devices are operated with the same statements and functions that are described here.

Storing Programs (STORE)

The STORE command stores a program file on a mass storage device for later retrieval. The command:

```
STORE "TAX"
```

causes a program named TAX to be stored on the default mass storage device. A file created by the STORE command is labeled as being file type PROG in a CATALOG listing.

If you want to store a program file on a device other than the mass storage device, you have to specify the location of the volume that you wish to store it on. For example, to store a program on a 7908 hard disc, enter the following command:

```
STORE "TAX:Q"
```

To store a program in memory into the same file name as before, use the RE-STORE Command. For example, if you want to store TAX to the default mass storage device and it is already there, you get an error (ERROR 54) when you execute STORE "TAX". In order to do this, you must execute RE-STORE "TAX".

Transferring Program Files into Memory (LOAD)

The **LOAD** command transfers a program file created by a **STORE** command from a mass storage device into the computer's memory. The command:

```
LOAD "TAX"
```

transfers the file **TAX** from the mass storage device into memory for your use. Note that if the file has been specially marked as run-only (see the **CATALOG** command section), it will begin to execute after being **LOAD**ed.

Storing Data Files (SAVE)

The **SAVE** command creates a **DATA** file and stores a program currently in memory on a storage device for later retrieval. The command:

```
SAVE "TAX"
```

saves the program **TAX** as a **DATA** file on the default mass storage device. You retrieve a data file stored by the **SAVE** command with the **GET** command.

Transferring Data Files into Memory (GET)

To transfer a data file created by the **SAVE** command from a mass storage device into the computer memory, use the **GET** command. For example, execute:

```
GET "TAX"
```

to transfer the data file **TAX** from the default device into memory.

Copying a File (COPY)

The COPY command duplicates a file, either on the same medium or on another medium.

Copying to the Same Mass Storage Devices

If you wanted to copy a file named TAX to the same mass storage device, you would execute the following command:

```
COPY "TAX" TO "INCTAX"
```

Note that you must name the destination file with a different name than the file you wish to copy. If you tried to copy the file TAX to another file TAX on the same mass storage device, you would get an error message (ERROR 54) which tells you that a duplicate file already exists.

Copying to a Different Mass Storage Device

If you need to copy a file onto a second mass storage device, the COPY statement can be used with a slight modification from the first example.

```
COPY "TAX:Q" TO "TAX:K"
```

This above command transfers a file named tax from the tape cartridge to the 7908 fixed disc. Since the files are on different media, they can have the same name.

Here is another example that uses labels, rather than unit specifiers, to designate media:

```
COPY "TAX,VOL1" TO "TAX,VOL2"
```

VOL1 and VOL2 are the names of two different media, that have been given via the PRINT LABEL command.

Cataloging Files (CATALOG)

The CATALOG command creates a listing (catalog) of the files stored on a mass storage device. This listing indicates whether or not those files are accessible, and provides information relating to that file. For example, if you need a CATALOG listing of the default mass storage device, execute the following command:

CAT

The first column of the table designates the file name. Any notation appearing in the PRO column indicates that the associated file is protected; this means that a file cannot be edited. Although files can be protected, restricted access can be allowed in the case of 2 protect codes, * and RO. If either of these codes is found in the PRO column, the associated file can be accessed by LOAD, GET, or RUN. However, unlike a file coded * , a file designated as RO is erased after being run, and cannot be displayed or listed. The TYPE label refers to one of the several file types. The most frequent types of files are PROG and DATA, which indicate program and data files respectively.

```

CAT ":F"
NAME  PRO  TYPE  REC/FILE  BYTES/REC  ADDRESS
UTILITY:F2,6,0
ACCEPT *   BPRG    4         256        60
BIT    *   BPRG    2         256        64
CATBIN *   BPRG    3         256        66
DATE   *   BPRG    3         256        69
DBPASS *   BPRG    4         256        72
DBSTOR *   BPRG   18         256        76
DBUTIL *   BPRG   15         256        94
DUP    *   BPRG    5         256       109
R-ONLY *   BPRG    1         256       114
REVCHK *   BPRG    1         256       115
TAPBIN *   BPRG    1         256       116
XCOPY  *   BPRG    4         256       117
BACKUP RO  PRG    59         256       121
BKSUB1 RO  PRG   203         256       180
BKSUB2 RO  PRG   168         256       383
BCKF1  *   FORM    6          256       551
BCKF2  *   FORM    6          256       557
BCKF3  *   FORM    5          256       563
BCKF4  *   FORM    3          256       568
BCKF5  *   FORM    4          256       571
BCKF6  *   FORM    4          256       575

```

Example of CAT Listing

System Commands

To obtain a catalog from a medium other than the mass storage device, you can use either the unit specifier or volume label. For example, if you wanted to see a catalog of the tape cartridge located in the tape drive, you would execute the following command:

```
CAT ":K"
```

You will then see a table listing of all files present on the tape cartridge.

If you wanted to obtain a catalog of a volume labeled HP250 (it could be any physical device), enter the following command:

```
CAT ",HP250"
```

Selective Catalogs

Suppose rather than obtaining a catalog of all files located on a specific mass storage device, you wanted just a listing of all files beginning with the letters HP or a listing of all type DATA files on a mass storage device. You can do this by adding some information to the CAT command.

For example, to obtain a listing of all files beginning with the letters HP that reside on the default mass storage device, you would enter the following command:

```
CAT "HP"
```

To obtain a listing of all files that are type DATA on a flexible disc, enter the following command:

```
CAT ":F",DATA
```

Finally, suppose you want to obtain a catalog listing of all programs beginning with the letters HP that are type PROG and reside on the 7908 fixed disc; enter the following command:

```
CAT "HP:Q",PROG
```

In all cases, the catalog is listed on the current system printer. This is usually the display. To obtain a hard-copy listing of a catalog, look at the section in this chapter on output commands.

Deleting Files from a Mass Storage Device (PURGE)

The **PURGE** command deletes a file from a mass storage device. You should use **PURGE** with caution; if you delete data by mistake, and have no back-up copy, that data is lost.

Assume that **TAX** is a file stored on a tape cartridge and is outdated or no longer required. You purge the file by executing the following command.

```
PURGE "TAX:K"
```

As soon as the **PURGE** has been performed, the cursor reappears on the display. If you try to purge a file that is not present on the particular storage device, you get an error message (**ERROR 56**).

If you would like to verify that the file **TAX** has been purged from the mass storage device, you can use a **CAT** command after you have executed the **PURGE** command.

Output Commands

Information output from your HP 250 takes three forms: **PRINT** outputs, **SYSTEM** outputs, and **PRINT ALL** outputs. All outputs are automatically output on the display screen after the system is powered on or reset. The display is called the default output device. Alternatively, you may specify other devices to output each type of information by using the appropriate statements described here.

There are several commands you can use to output information. They are the **PRINTER IS**, the **SYSTEM PRINTER IS**, and the **PRINT ALL IS** commands. The table below gives you a general summary of these commands.

Output Type	Operations Affected	Controlled By
PRINT SYSTEM	PRINT, PRINT USING LIST, CAT, TRACE, Single-Step Output	PRINTER IS SYSTEM PRINTER IS
PRINT ALL	All displayed information	PRINT ALL IS

Peripheral Addresses

Each peripheral device connected to your HP 250 responds to a unique address. The address is a number between 0 and 20. Switches on each device are used to set each address. The following table is a list of the numbers that you will use to direct output to printers.

0 through 5	System Printers
8	Display
10 through 20	Remote printers connected to workstation

Outputting Listings and Catalogs (SYSTEM PRINTER IS)

The `SYSTEM PRINTER IS` statement assigns the device used for all `SYSTEM` outputs; these include the `CAT` and `LIST` commands.

To specify the system printer as the output device, enter the following command:

```
SYSTEM PRINTER IS 0
```

Suppose you want to print a catalog listing of a volume on a printer, rather than displaying it on the screen. You would execute the above command, followed by the appropriate `CAT` command. When you no longer wanted to direct information to the line printer, enter the following command:

```
SYSTEM PRINTER IS 8
```

After executing this statement, all information is displayed to the screen only.

Printing all Displayed Information (PRINT ALL IS)

To obtain a permanent copy of all of your interactions with the system, you use the `PRINT ALL IS` command to specify a device other than the display. For example, suppose you want to use the system printer to record all of your interactions. Enter the following command:

```
PRINT ALL IS 0
```

If you no longer wish to record all of your interactions with the system, enter the following command:

```
PRINT ALL IS 8
```

If your workstation has an optional thermal printer, you can record all of your interactions with the system by entering:

```
PRINT ALL IS 10
```

Setting a Printer to Top of Form

The `PRINTER IS` command assigns the output device for all `PRINT` and `PRINT USING` operations, which are normally issued within a program. Each successive `PRINTER IS` statement cancels the previous one. Therefore, if you specify a device with this statement, it is overridden if a program you run sets the printer to another device. For most intents and purposes you will not issue this command.

There is one place where this command might prove to be useful. If you wish to set a printer to the top of the form, you use the `PRINTER IS` statement followed by a `PRINT PAGE` statement.

For example, if you wanted to set a printer at address 0 to the top of form without walking to the printer, you would enter the following sequence:

```
PRINTER IS 0  
PRINT PAGE
```

If you wanted to send the thermal printer to the top of form, enter the following command:

```
PRINTER IS 10
```

followed by:

```
PRINT PAGE
```

If you look carefully at the thermal printer paper, you will notice a small tick mark. This tick mark is the bottom of form. It is printed so that you can distinguish between pages easily.

CHAPTER 9

Maintenance

Maintenance of your HP 250 and associated peripherals (disc drives, printers, plotters, consoles) is limited to periodic cleaning of the external surfaces. Cleaning intervals are determined by the type of operation, local air contamination, and climatic conditions.

WARNING

Disconnect devices from the power source prior to performing any maintenance. While cleaning, apply water using a lint-free cloth or sponge. Do not allow water to run into electrical components or circuits, or through openings in any enclosure as it may create a shock hazard.

General Cleaning

- 1) Get rid of any accumulated dust by vacuuming the surrounding area.
- 2) Clean outer surfaces only. Use only mild soap and water on a damp sponge or cloth. Do not use an abrasive cleanser; using one can result in scratches on the surface you are cleaning. Wipe all surfaces dry after cleaning; be sure that moisture does not get into the keyboard of your workstation or any other part of the system.

More detailed instructions for system peripherals are presented in separate reference manuals.

REMINDER

When you have finished, remember to reconnect all devices as before.

CHAPTER 10

In Case of Difficulty

In the event that your system becomes inoperable, you should take action to pinpoint the problem. By checking the system yourself, you may be able to avoid calling for service. In any case, you can minimize the time needed to get your system back into operation.

When you get an error, you should do things the SLOW way:

Stop what you are doing

Look up error message or procedure described in this manual

Observe what is on the screen

Write down this very important information.

Generally, any difficulty you encounter falls into 1 of 2 categories.

- Start-up errors
- Processing Errors

One classic symptom of a start-up error is that the cursor does not appear on the screen. (Although this is not always true).

Processing errors can be caused as a result of hardware failures, software errors, or operator errors. They may result in a loss of the cursor and program control. They also may result in an inability to access certain data, print reports or plot charts.

Start-Up Errors

Self-Test Failure

The HP 250 automatically tests itself each time you turn it on. The test checks the system for hardware failure. Results of the test are displayed on the principal workstation.

If any component of the self-test fails, you should turn your HP 250 off and then back on again.

If any component of the self-test fails on successive reloads, make a note of the message on the screen.

If the problem occurs intermittently (i.e., not on successive reloads), keep a record of the occurrence and the circumstances leading up to the error.

Once all the tests have passed, loading the operating system is started.

System Loading

If the message:

"The 'SYSTEM' file was not found"

appears on the principal workstation after repeated attempts to reload, or a different error occurs, reload using a back-up copy of the operating system.

If this procedure is unsuccessful, you should record the resulting error message and contact HP for service.

If the message:

"The system is waiting for the disc to warm up"

appears on the principal workstation, you should wait a few moments and retry the start-up procedure. If this message appears repeatedly or a different error occurs, record the resulting error message and contact HP for service.

Loader Errors

If you encounter a loader error, consult the proper section in the Appendix with error messages.

For example, if the following message:

LOADER ERROR B

appears on the principal workstation, you will find that this resulted from a disc read error (by looking in the appendix with error messages). Loader errors A through C may indicate that the medium holding the Operating System is worn or damaged. Try loading the system with the backup copy of the Operating System disc. If any loader error persists after repeated tries, record the error message and call HP for service.

Configuration Messages

Configuration messages indicate an inconsistency in hardware/operating system configuration. Although your HP 250 system can operate with these inconsistencies, they should be corrected as soon as possible.

For example, if the message:

MEMORY FAILURE - BLOCK 10

appears, either the Operating System was told (via the CONFIG Utility Program) to expect more memory than available or a memory block has failed. Consult your principal operator to remedy this problem. Other configuration messages are described in Appendix E.

Remote Workstation Failure

In the event that your remote workstation is unoperable (either the cursor does not appear or there is no response to the keyboard), you should take appropriate action to pinpoint the problem. By checking the workstation yourself, you may be able to avoid calling for service.

In Case of Difficulty

There are three basic steps you can perform:

1. Ensure that the workstation is plugged in, powered on, and cabled properly.
2. Use the TEST key to determine if your workstation is functioning. The TEST key is described in Chapter 3. If an error message appears as a result, record the error message.
3. Have your principal operator run the CONFIG utility program to determine if the operating system is configured to use the remote workstation.

Processing Errors

As described before, processing errors are caused as a result of hardware failures, software errors, or operator errors.

Hardware Failures

Hardware errors can also occur during processing. They are noted by error messages as listed in Appendix E.

If you get a hardware error, note all conditions preceding the error: try to recall the key sequence you pressed, any error message, and also all environmental conditions.

Software Errors

Software or programming errors are caused by an error in a program being run on your HP 250 system. Given the identical set of operating conditions, a software error will occur repeatedly. It occurs when the program is loaded and run.

If a software error occurs, note all conditions preceding the error: record the key sequence you pressed, any error message (and line number if indicated), the number of the form or report presently being used, incorrect program output. If the keyboard is unresponsive due to the error, press the HALT key to stop the program. If that is not effective, press SHIFT HALT. If the keyboard continues to be unresponsive, press CNTL HALT.

Operator Errors

Operator errors are caused by attempting incorrect procedures, inappropriate commands, or commands with incorrect form. If you encounter an operator error, it is probably a result of a typographical error.

System Errors

Some special system malfunctions are denoted with the words:

SYSTEM ERROR

If a system error occurs while a program is executing on the HP 250, you see a screen similar to the one shown at the bottom of this page.

When this occurs, perform the following sequence of steps:

- 1) Record the entire contents of the screen on a piece of paper. In addition, you should write down what you were doing when the system error occurred; the program you were running and programs other users were running can provide important background information. You should also record anything else you may have observed which you feel may be important. A sample of this is displayed below.

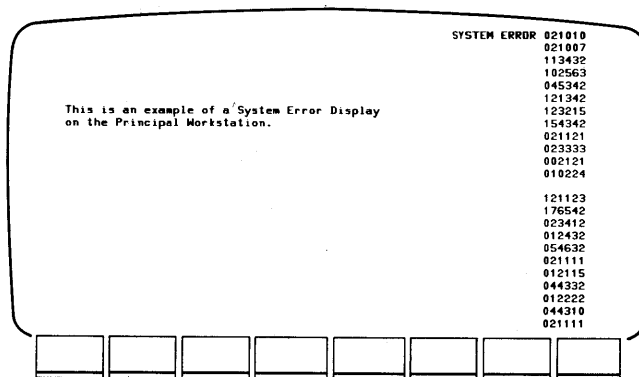

In Case of Difficulty

- 2) To produce a printed report of the system error on the system printer at address 0, press the ENTER key located next to the data entry pad. To produce a report on the system printer at address 15, press the EXECUTE key.

Keep this report with the copy of the screen contents from Step 1 for future reference. Together, they provide information that is extremely valuable in diagnosing problems that may exist.

NOTE

If you press the ENTER key and get no response, do not be alarmed. There are several conditions that may cause this. Proceed to Step 3.

- 3) Start the system up again (see Chapter 2 for details).
- 4) Notify your customer engineer about the system error.

If the System Error problem persists, repeat the previous series of steps.

System Tests

The computer automatically performs a series of internal tests immediately after power is switched on. You can perform additional tests to verify system operation by running the TEST program, which is included with the system software. Tests are available for checking the keyboard, display, printer, and mass storage media.

Except for the keyboard test, all tests described here can be run from any workstation.

To run the TEST program, enter the following command:

RUN "TEST"

Then select the test from the initial test menu:

SYSTEM TESTS

HP250.3.93.B

DISPLAY TEST - Provides utilities for CRT re-adjustment and testing.

PRINTER TEST - Allows system printers to be tested.

MEDIA TEST - Allows HP format media to be tested, and provides a limited class of error recovery facilities.

IBM MEDIA TEST - Allows IBM format media to be tested.

PLOTTER TEST - Checks plotter configuration and exercises GPL.

MISC. TESTS - Provides tests for various other parts of the 250 hardware.

Please select a function.

DISPLAY TEST	PRINTER TEST	MEDIA TEST	IBM MEDIA TEST	PLOTTER TEST	MISC. TESTS		EXIT PROGRAM

The MISC.TESTS softkey accesses the keyboard test described later.

Display Tests

Press the DISPLAY TEST softkey to list the available display tests:

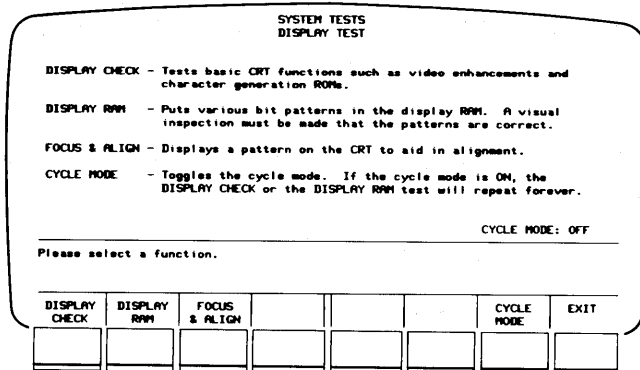

The DISPLAY RAM and FOCUS & ALIGN tests are intended for service use only.

Pressing the DISPLAY CHECK softkey first shows a series of inverse-video fields, allowing you to check the screen for blank areas or stray dots. Then the entire character set is displayed.

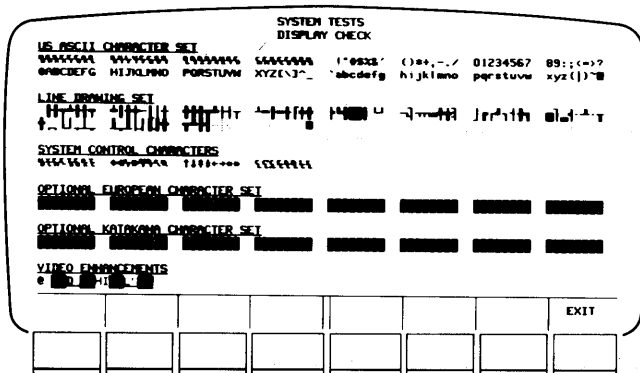

The optional European and Katakana character sets are not displayed unless they are configured to be loaded with the operating system.

After examining the final display, press EXIT to return to the DISPLAY TEST menu. Press EXIT again to return to the SYSTEM TESTS menu.

Printer Test

Press the PRINTER TEST softkey to select and test each printer in your system.

SYSTEM TESTS PRINTER TEST							
PRINTER TEST - Tests the currently selected printer. Various options are available when testing each kind of printer. SELECT PRINTER - Allows the printer to be tested to be specified. CYCLE MODE - Toggles the cycle mode. If the cycle mode is ON, the PRINTER TEST will repeat forever.							
Printer is currently CRT. CYCLE MODE: OFF							
Please select a function.							
PRINTER TEST				SELECT PRINTER		CYCLE MODE	EXIT

The printer currently selected is displayed on the right. To select another printer, press SELECT PRINTER. Now the device addresses of the printer(s) currently on-line are displayed. Specify the device address of the printer to be tested by pressing the appropriate softkey. The next menu offers a choice of tests:

SYSTEM TESTS PRINTER TEST							
PROCEED - Runs standard printer test. RIPPLE PRINT - Runs a ripple print test. This test runs until the EXIT key is pressed.							
Printer is currently D. CYCLE MODE: OFF							
Please select a function.							
PROCEED				RIPPLE PRINT			EXIT

After selecting the test, compare the final printout with the original test printout kept with the system. If characters are missing or misformed, contact HP for service. Note that light character printout could be caused by either a worn or defective ribbon, or a dirty print head. Refer to the printer section of this manual or the printer's operating manual for details on changing ribbon or cleaning the print head.

Press EXIT to return to the SYSTEM TESTS menu.

Media Test

Press the MEDIA TEST softkey to select and test each mass storage medium in the system:

SYSTEM TESTS MEDIA TEST							
VERIFY	- Verifies a media using tight margin read. Will optionally attempt to recover certain classes of errors.						
CHECK AVT	- Rebuilds the availability table from the directory. Will report any overlapping files which occur.						
RECORD 0 RECOVERY	- Will attempt to recover a media which is giving error 85's because of a trashed sector 0.						
SELECT DEVICE	- Allows the device to be tested to be specified.						
Currently selected device is :F2,6,0.							
Please select a function.							
VERIFY	CHECK AVT	RECORD 0 RECOVERY		SELECT DEVICE			EXIT
<input type="button"/>	<input type="button"/>	<input type="button"/>	<input type="button"/>	<input type="button"/>	<input type="button"/>	<input type="button"/>	<input type="button"/>

The VERIFY softkey runs a test which reads each file on the media. The CHECK AVT and RECORD 0 RECOVERY softkeys provide error recovery routines, as described later.

Pressing SELECT DEVICE lists the mass storage devices currently in the system. The next menu, for example, lists the flex disc, 7906 fixed disc, and the 7906 removable disc as ready.

SYSTEM TESTS SELECT DEVICE							
LABEL	DEVICE	COMMENT					
	FLEX DISC	:F2,6,0					
	SYSTEM	7906 CART :C2,7,0					
	BACKUP	7906 FIXD :D2,7,0					
Currently selected device is :C2,7,0.							
Please select a device.							
FLEX DISC :F2,6,0	7906 CART :C2,7,0	7906 FIXD :D2,7,0					EXIT
<input type="button"/>	<input type="button"/>	<input type="button"/>	<input type="button"/>	<input type="button"/>	<input type="button"/>	<input type="button"/>	<input type="button"/>

Press the appropriate softkey to select the device and return to the MEDIA TEST menu.

Press VERIFY to start the media verification routine. Now select whether the routine should automatically log any disc errors encountered and continue (press W/O RECOVERY) or halt when encountering a disc error (press WITH RECOVERY). The flex disc test takes a minimum of 2 minutes; longer if errors are encountered. A display message indicates the test progress:

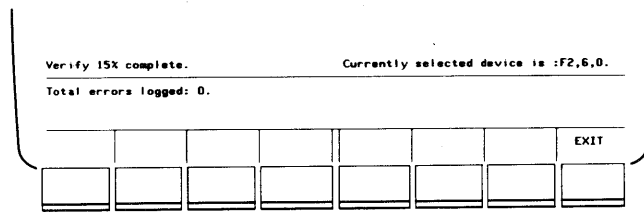

When W/O RECOVERY is selected, the final display indicates the number of errors logged and where each error occurred. For example:

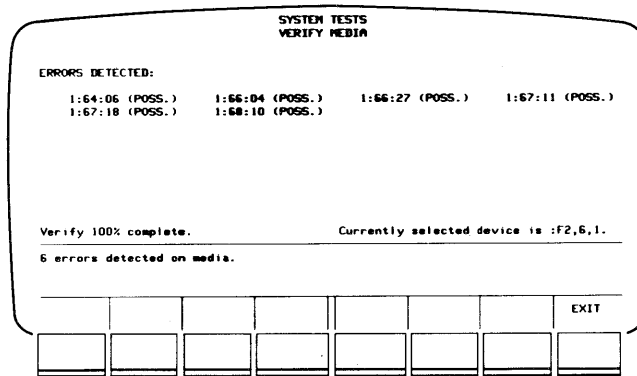

Each entry in the error list indicates the head, track, sector and error type. "POSS." indicates a read-data error which is possibly recoverable by running VERIFY and selecting WITH RECOVERY.

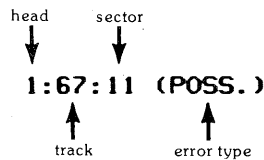

In Case of Difficulty

An * appears in place of the sector number when successive sectors of a track cause errors. When testing a flex disc, head 0 is the bottom side and head 1 is the top side.

When WITH RECOVERY is selected, the test stops to display the location and type of each error. You may choose to attempt to recover (re-write) the file (press YES) or simply log the error and continue (press NO). If the recovery fails, note the file name so you can attempt to manually read the file later.

- For type PROG files, manually recover by LOADING and SAVEing the file. Then press CTRL HALT to erase any unexpected code. Now GET the program and RE-STORE it on another media.
- For type DATA files, attempt to GET or manually read the data.
- For type DSET or ROOT files, attempt to do a serial unload (DBUNLD) and recreate the file as described in the System Utilities Manual.

All other file types are not recoverable except via the VERIFY routine.

IMPORTANT

The detection of any errors on a media indicates that either the media is worn or defective or the drive requires service. After running VERIFY with recovery, the media should be backed up onto a known good media. Consult your principal operator for details.

If Error in Main Directory appears when running WITH RECOVERY, press EXIT and then press CHECK AVT to rebuild the availability table. If the AVT fails, press RECORD 0 RECOVERY and copy the spare directory to the main. Then run CHECK AVT again. Once the main directory and availability table appear OK, run VERIFY again.

IBM Media Test

Press the IBM MEDIA TEST softkey to select and test IBM 1/4 megabyte flexible discs.

SYSTEM TESTS MEDIA TEST							
VERIFY	- Verifies an IBM 1/4 mbyte media using tight margin read.						
SELECT DEVICE	- Allows the device to be tested to be specified.						
Currently selected device is none.							
Please select a function.							
VERIFY			SELECT DEVICE				EXIT

The VERIFY softkey runs a test which reads each file on the media.

Pressing SELECT DEVICE lists the mass storage devices currently in the system and indicates the storage media that are eligible for testing.

SYSTEM TESTS SELECT DEVICE		
LABEL	DEVICE	COMMENT
UTILITY	FLEX DISC:F2,6,0	unavailable (not IBM 1/4 mbyte format)
IBMDEM	FLEX DISC:F2,6,1	
Currently selected device is none.		
Please select a device.		
	IBMDEM :F2,6,1	
		EXIT

Press the appropriate softkey to select the device and return to the IBM MEDIA TEST menu.

Press VERIFY to start the verification routine. Displayed messages indicate test progress, total errors logged, and where each error occurred.

Keyboard Test

Press the MISC. TEST softkey on the SYSTEM TEST menu to access the keyboard test. The other miscellaneous tests are intended for service use only.

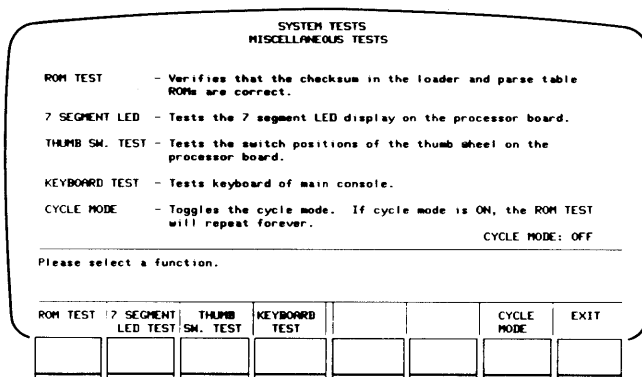

Press KEYBOARD TEST to display representation of the main console keyboard.

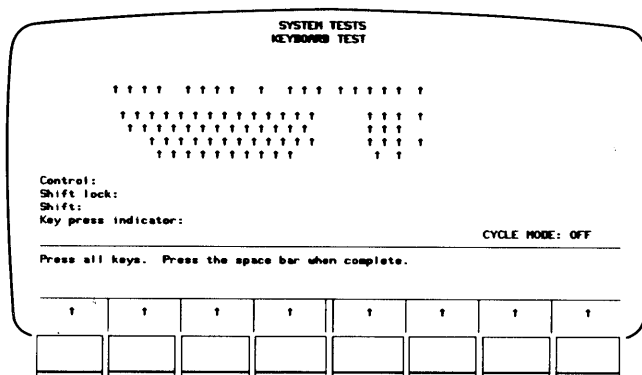

As each key is pressed, its corresponding up arrow is replaced by an *. Arrows appear on the left to indicate whether CTRL, or is pressed with another key. The "key press indicator" changes position as each key is pressed. Be sure to also test the display softkeys.

If the key press indicator does not change position each time a key is pressed, that key is defective. Call HP for service.

Press the space bar to return to MISCELLANEOUS TESTS menu.

Plotter Test

Press the PLOTTER TEST softkey to select and verify any plotters connected to your HP 250 system. The initial menu describing the test appears:

RUN "GPLCFT"		HP 250 PLOTTER/SYSTEM CONFIDENCE TEST					
		Introduction					
Objectives of this test:							
1. Verify that a graphics plotter is properly connected and configured to your HP 250 Computer System.							
2. Verify that required plotter functions are working.							
You should:							
1. Turn on your plotter and load clean paper.							
2. Follow the rest of the instructions in this program.							
3. Examine the plot and compare with the picture in the manual OPERATING THE HP 250.							
4. If the picture is incorrect, see OPERATING THE HP 250 for further instructions.							
Please be sure that no picture detail is missing.							
Press CONTINUE when your plotter is ready.							
CONTINUE							EXIT PROGRAM

Press the CONTINUE softkey. The screen appears as follows:

In Case of Difficulty

HP 250 PLOTTER/SYSTEM CONFIDENCE TEST
Plotter Selection

Model Number	Device Address
7221S	11
7221T	12
7225A/3V	13
7225B/4V	14

Please select your device by pressing the appropriate softkey.

7221S 11	7221T 12	7225A/3V 13	7225B/4V 14			EDIT GPL%CF	EXIT PROGRAM
<input type="button"/>	<input type="button"/>	<input type="button"/>	<input type="button"/>	<input type="button"/>	<input type="button"/>	<input type="button"/>	<input type="button"/>

You may now either test any of the devices previously configured or edit the plotter configuration file (GPL%CF). If you are getting started and need to add a plotter, or wish to change or delete an already configured plotter, press the EDIT GPL%CF softkey.

Adding, Changing, or Deleting Plotters

When you press the EDIT GPL%CF softkey, the following menu appears:

HP 250 PLOTTER/SYSTEM CONFIDENCE TEST
Plotter Selection

Model Number	Device Address
7221S	11
7221T	12
7225A/3V	13
7225B/4V	14

Please select the edit option.

ADD PLOTTER	CHANGE PLOTTER	DELETE PLOTTER	EXIT EDIT
----------------	-------------------	-------------------	--------------

ADD PLOTTER Adds a plotter to the configuration file. When you first start up, you must specify the plotter type and address here. After pressing the ADD PLOTTER softkey, you will be presented with several menus which allow you to specify the model number, model type, and device address; if you are unsure of the model type, look at the plotter.

CHANGE PLOTTER Changes an existing plotter configuration. After pressing this key, you will be presented with several menus which allow you to change the model number, model type, and device address of any plotter.

DELETE PLOTTER Allows you to delete any plotter which you have previously configured.

In Case of Difficulty

Running the Confidence Test

When you select a plotter to be tested, the first screen to appear is the following:

The screenshot shows a terminal window with the following text:

```
HP 250 PLOTTER/SYSTEM CONFIDENCE TEST
Plotter Address Selection
Plotter: HP 72215 Graphics Plotter.

Please select plotter address.
```

Below the text is a row of eight softkeys. The first key is labeled '11', the fifth key is labeled '8', and the eighth key is labeled 'EXIT'. Each key is represented by a small rectangular box with a horizontal line above it.

11				8			EXIT
----	--	--	--	---	--	--	------

Press the leftmost softkey to draw the confidence plot on the plotter. If you press the softkey with the value "8", all data will be sent to the display.

After selecting the output device, you may choose to do either a SIMPLE or COMPLETE confidence test. Sample plots showing the difference between the two appear at the end of this chapter.

When you press the COMPLETE softkey, two menus are presented, which allow you to enter an optional date and run number.

If you have specified an output device other than the CRT (8), and have either pressed the SIMPLE softkey or completed the date and run number information for the COMPLETE test, you now specify the type of paper on which the confidence plot will be drawn.

After selecting the type of plotter paper, you will be presented with several different paper sizes. If you are not sure of the type of paper to use, see Chapter 7 of this manual.

When you have provided all of the plotter paper information, the following menu appears:

HP 250 PLOTTER/SYSTEM CONFIDENCE TEST

Plotter: HP 72215 Graphics Plotter.
Plotter address: 8

Test: SIMPLE

Paper: ISO A4 size plot (210 mm x 297 mm) on metric roll paper.

When ready to start plotting, please push START PLOTTING.

START PLOTTING								EXIT

Press the START PLOTTING softkey to begin the test. At any time during the test, you may press the ABORT PLOT softkey.

When the test is complete, the following menu appears:

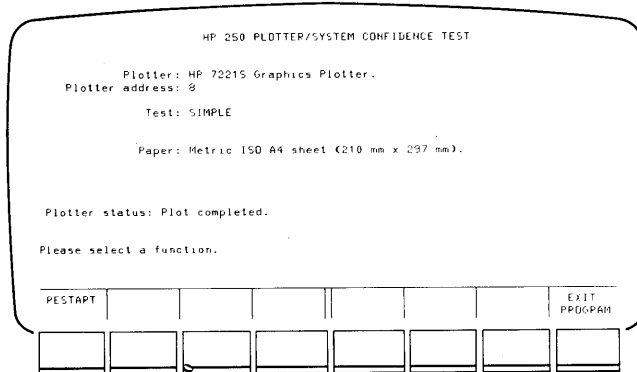

You may now restart the plotter test, exit the plotter test, or return to the TEST utility main menu.

Look at the plot drawn for the confidence test. Compare it to the samples shown on the following pages. If the result of the test is a partial plot or no plot at all, there may be something wrong in the system connection or the device. Consult your principal operator to ensure that everything is connected properly.

NOTE

The number of pens and several other parameters in the upper right hand corner of the picture are dependent on the model of the plotter.

SIMPLE Test Result

TEST
COMPLETED

COMPLETE Test Result

GPLCFT - GRAPHICS DEVICE/SYSTEM CONFIDENCE TEST

11/23/81
Run# 1
7220C
Device address=17
Buffer size=928 bytes

Slowest velocity test.

<p>NINE LINSTYLES</p> <p>0 _____</p> <p>1 _____</p> <p>2 3 - - - - - 4 - - - - - 5 - - - - - 6 - - - - - 7 - - - - - 8 - - - - - 9 - - - - -</p> <p style="writing-mode: vertical-rl; transform: rotate(180deg);">TEXT ROTATION=1</p>	<p>EIGHT PENS</p> <p>1 _____</p> <p>2 _____</p> <p>3 _____</p> <p>4 _____</p> <p>5 _____</p> <p>6 _____</p> <p>7 _____</p> <p>8 _____</p> <p style="writing-mode: vertical-rl; transform: rotate(180deg);">TEXT ROTATION=3</p>
---	--

TEXT ROTATION=2

```

! "$%&' () *+, - . /
0123456789: ; <=>? - . " çÑñ ¡¿¤£¥$
@ABCDEFGHIJKLMNO âêôûáéóúàèòùãëõü
PQRSTUVWXYZ [\]^_ ÅîøÆåíøæÄiÖÜÉÏß
`abcdefghijklmnop
qrstuvwxyz{|}~

```

TEST
COMPLETED

Revision HP250.3.94

APPENDIX A

Glossary

alphanumeric characters - letters, numbers, and punctuation marks.

applications software modules - computer programs to solve business related problems such as inventory, accounts receivable, order entry, etc.

backing up - duplicating or copying files on a medium after significant modification.

BASIC - an acronym for Beginner's All-purpose Symbolic Instruction Code; a popular, easy-to-learn programming language used on the HP 250 computer system.

binary program - an extension of the operating system, invoked by the user, that provides BASIC language enhancements.

bit - an abbreviation for binary digit, which is a unit of information equal to either 0 or 1.

byte - a sequence of eight bits operated on as a unit, which is the smallest accessible amount of information in the computer.

command - an operation which can be executed only from the computer keyboard; it cannot be used in a program.

console - the part of a computer used for communication between the operator and the computer. See workstation.

CPU - (Central Processing Unit), the part of the computer that controls all computer components and operates on data.

CRT - (Cathode Ray Tube), a synonym for the display or screen.

cursor - the flashing underscore which appears on the display that points out the current character position.

data base - a collection of related data sets (files).

data integrity - the validity of data or information.

data set - a data base file that contains data entries (records).

Glossary

defective tracks - a track on a storage medium where reading and writing of data is not possible, usually because of a scratch, dirt, or lack of magnetic oxide on the surface of the disc. If any defective tracks exist, they are identified during the media initialization process (the INIT utility program).

disc - a storage medium for the HP 250.

display - a television-like screen used for outputting data, messages, and other information to the operator.

display editing keys - a set of keys used to position the cursor at specific locations on the display to modify data

directory - a "table of contents" showing the name, type, and number of files recorded on a disc.

disc drive - the device used to transfer data between disc media and computer memory.

disc drive code - the number of the disc drive unit.

diagnostic - a test that the system performs on itself.

DROM - (Discrete Relocatable Optional Module), a system software module which can be configured to be loaded into system memory at power-on.

exponentiation - raising a number to a power. For example:
 $2^{**}3 = 2*2*2 = 8$

editing - correcting errors, whether typographical or non-typographical, and modifying program lines and data.

error message - an English phrase or number describing an error that has occurred during execution. An error number refers to a detailed description of the problem (see the appendix titled Error Messages).

expression - one or more variables, numbers, functions, etc., grouped together with operators (+, -, *, /, etc.), and mathematically or logically evaluated to a single value.

file - a file is one or more logical records written on a storage medium. It consists of contiguous sectors which hold information such as programs or user-defined data.

flexible disc - one of the storage media for the HP 250. Data is written on a thin magnetic oxide film coated on plastic. The disc is enclosed in a sealed plastic jacket for protection.

floppy disc - another name for a flexible disc.

form feed - The ability of the printer to automatically advance to the next form or page of paper for printing.

field - a "window" or section of the display line where input or output is allowed.

function - a BASIC language operation which returns a number or value, and can be executed either from the keyboard or programmatically.

hardware - the physical equipment of your computation system.

hardware error - an error associated with a mechanical failure of a component of your system.

mathematical hierarchy - a list of priorities or procedures regarding relational operators, functions, and punctuation.

initialization - a process that writes addresses on a storage medium, tests the writing and reading patterns from the disc, and sets up the directory to keep track of files.

keyboard - a set of keys used to input information and program lines. It typically consists of a typewriter block, data entry pad, halt and execute keys, special function keys, and display editing keys.

mass storage device - a device used to store program and data.

medium - the material on which data is recorded (e.g. tape cartridge, flexible disc, etc.).

null string - a string variable containing no characters; it is often designated as "".

numerical range - the range of limits on the value of numbers output by the HP 250.

numerical value - the value of an expression represented as a decimal, an integer, or in scientific notation.

operand - the expression that is being operated upon by a function, or a relational or arithmetic operator. For example:

$$2 + 8$$

operator error - an error caused by attempting an improper key sequence, command, or procedure.

Glossary

operating system - the software associated with the computer and its processing capabilities.

output - to yield the results of processed data; often refers to the results itself.

parameters - variables in a command or statement whose values are defined by the user.

password - a unique code, usually a number or a name. used to access an applications software module or data base information.

peripherals - devices used for input/output operations which are compatible for use with the HP 250. Examples are the cartridge tape drive and the printer.

precision - the number of digits allowed per data element. Real (full) precision allows 12 digits, short precision allows 6 digits, and integer precision allows numbers from -32767 through 32767.

principal workstation - the integral workstation on the HP 250/35 or the workstation connected to Port 1 of the HP 250/30. It is the workstation where loading and System Error information is displayed.

program - a sequence of instructions or statements that a computer interprets and executes.

record - a block of 256 bytes of data written on the disc.

scientific notation - a form of writing a number as a decimal times a power of 10. Example: $1.0E6 = 1,000,000$

scrolling - refers to the movement of the display up and down. Scrolling occurs when you enter a new line at the bottom of the display or when you use the xxxx and xxxx keys at the top or bottom of the screen.

softkeys - special function keys that are defined to perform a series of keystrokes or branch to a program line.

software - programs which are loaded into your system from a storage medium.

software error - a logical or syntactical error encountered in a program that is being executed.

special function keys (SFK) - user definable keys on the HP 250. Each key can be dynamically defined as a typing or programming aid. Also known as softkeys.

spooling - temporary storage of data or programs on mass storage files, allowing the system to continue processing while an output device is used.

statement - a numbered line stored in computer memory. A collection of statements is known as a program.

storage device - a mechanism that holds a medium for recording information for later retrieval.

string variable - a variable which represents a series of alphanumeric characters.

syntax - the formal required structure of a program statement.

system software - the operating system and language enhancements which are loaded into a reserved, protected segment of memory. System software is not erased by loading and running programs.

task - the actual or potential activity of HP 250 program execution.

variable name - a name representing a location in memory where data such as numbers, alphanumeric strings, and numeric arrays are stored. The value of this data can be modified.

volume - the physical medium on which data and programs are stored.

word - two bytes of information.

workstation - the part of a computer used for communication between the operator and the computer. See console.

APPENDIX B

Keyboards

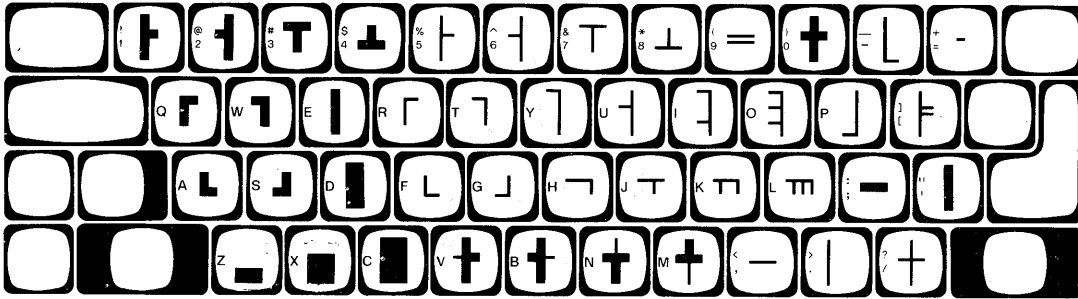

Unshifted Line-Drawing Keyboard

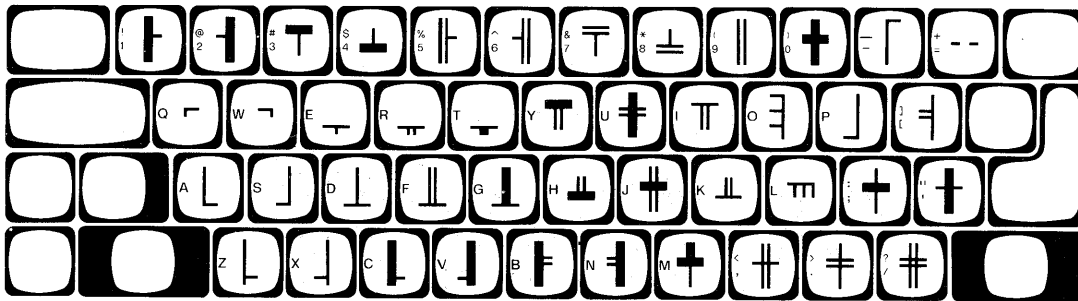

Shifted Line-Drawing Keyboard

NOTE

Refer to Appendix C, The Config Program, for instructions on defining the primary and secondary keyboard loaded at power-up.

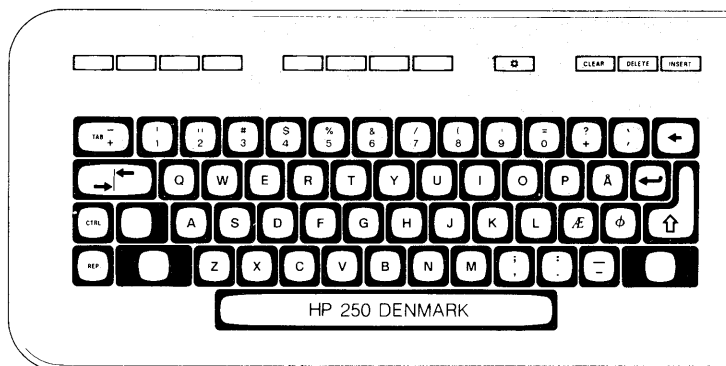

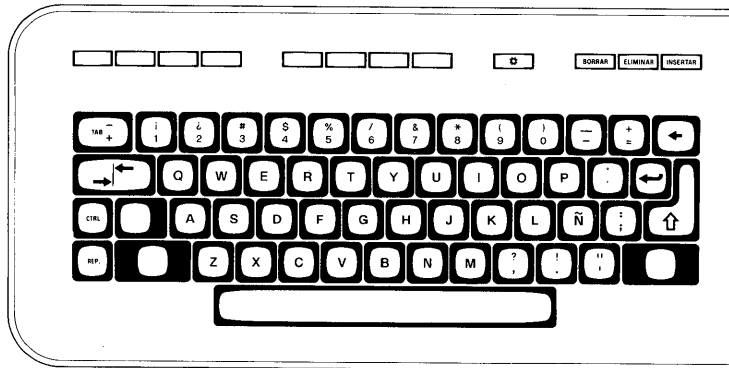

Spanish Language Keyboard

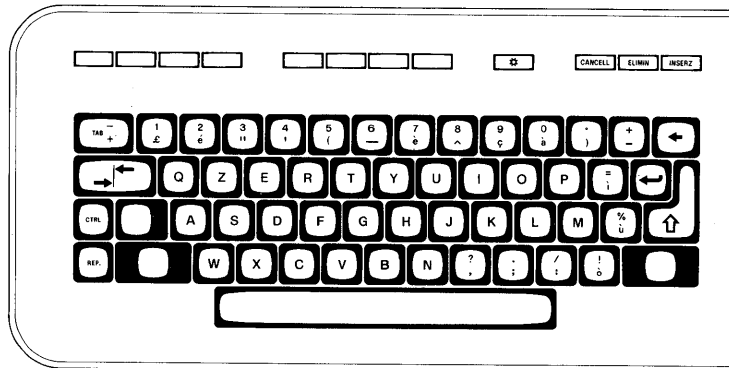

Italian Language Keyboard

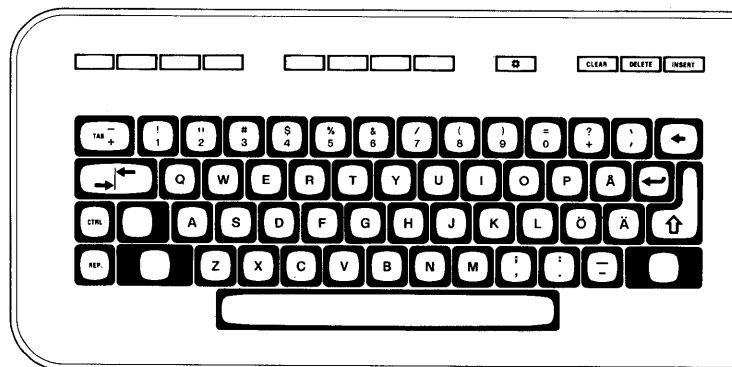

Swedish Language Keyboard

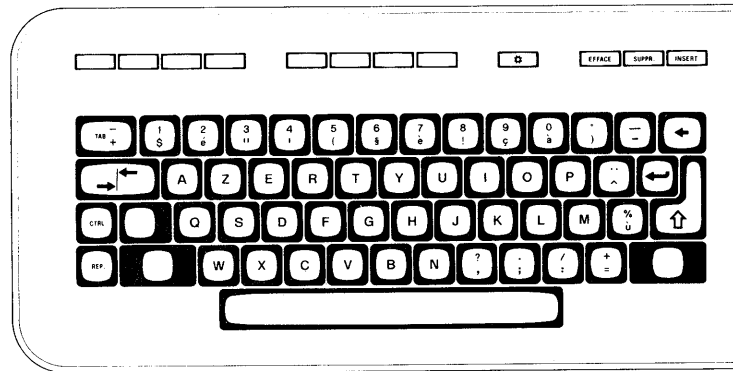

French Language Keyboard

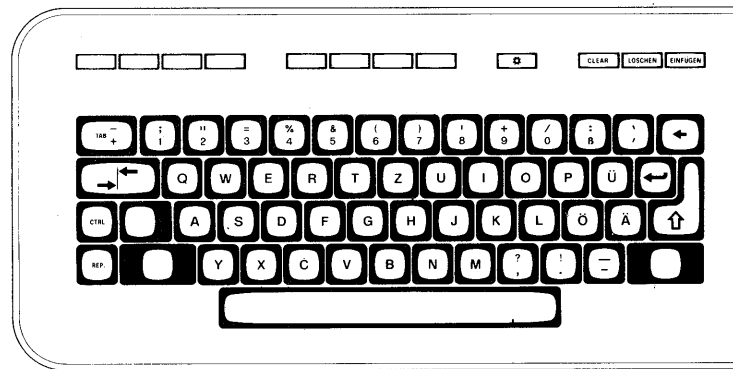

German Language Keyboard

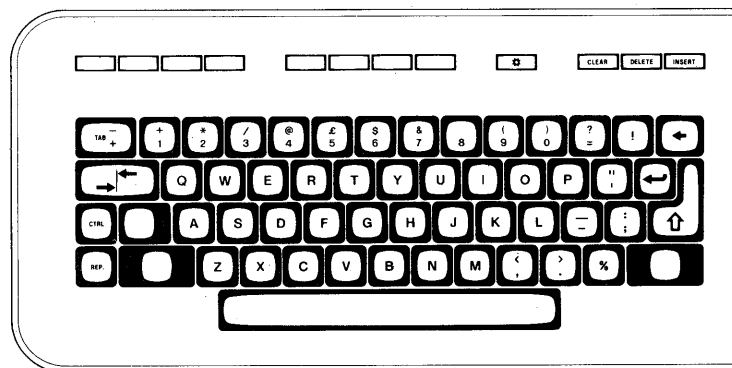

United Kingdom Language Keyboard

APPENDIX C

Volume Specifiers

This appendix describes the physical unit specifiers which are used to tell your HP 250 the device you wish to access.

In Chapter 8, you saw how several commands associated with files (such as CAT and PURGE) were used. You had to specify either the volume label (the name assigned to a storage medium via the PRINT LABEL command) or the physical unit specifier.

The physical unit specifier consists of several parameters to be specified in this order (optional parameters are enclosed in brackets). The physical unit specifier is always preceded by a colon.

```
:device type [select code [,device address [,unit code] ] ]
```

The various device types are:

Device	Letter
Flexible Disc Drive	F
7906 Removable Disc	C
7906 Fixed Disc	D
7910 Fixed Disc	L
Cartridge Tape Drive	K
7908 Fixed Disc	Q
7911 Fixed Disc	R
7912 Fixed Disc	S
5 Mb. Disc	G

Physical Unit Specifiers

select code can be an integer from 1 through 15. It is not required. The HP 250 system automatically sets it to 2. (optional)

device address can be an integer expression from 0 through 7.

Device Address	Disc
0	printer
1	printer
2	optional
3	optional
4	Integrated Storage Unit
5	7906 (C/D)
6	Flexible Disc
7	7910 or 5 Mb. Disc

unit code can be an integer expression from 0 through 7. For an Integrated Storage Unit (HP 7908, 7911, or 7912 disc plus cartridge tape drive), the disc unit code is always 0 and the tape unit code 1. (optional)

APPENDIX D

Using Softkeys as Typing Aids

Each softkey can be defined for use as a keyboard typing aid to reduce a series of up to 160 keystrokes to one touch of a key. You can store and load typing aid definitions from mass storage devices as a file, so that the keys do not have to be continually redefined.

A softkey can be defined in two ways:

- 1) The ON KEY statement is used to define a softkey within a program; pressing a softkey with an active ON KEY definition causes an interrupt which can be detected by the program.
- 2) You can assign a typing aid definition to a softkey directly from the keyboard (via the EDIT command).

When a softkey is defined in both ways at the same time (via the ON KEY statement and via the keyboard), the definition assigned with the ON KEY statement always has priority. After the ON KEY definition has been deleted, the typing aid definition can be accessed.

What follows is a discussion on how you can use softkeys as typing aids.

Defining Softkeys as Typing Aids

To define or edit a softkey as a typing aid, you perform the following 3 basic steps:

- 1) Execute the following statement:

```
EDIT KEY# key number
```

or type the word EDIT and press the softkey you wish to define. Doing this places the keyboard in edit mode.

- 2) Type in the character sequence that you wish to store in the softkey.
- 3) Store the typing aid definition in the softkey by pressing the softkey. This causes the system to exit the edit mode. If you wish to exit the edit mode without storing the definition, press the HALT key; in this case, any previous typing aid definition is retained. This definition exists as long as the system is running. To permanently store a softkey definition, see the section headed "Storing Typing Aid Definitions".

Erasing Typing Aid Definitions

For a single key: To erase a typing aid definition for a single key, type in SCRATCH and then press the softkey you want to erase.

For all keys: To erase all typing aid definitions, execute the following command:

```
SCRATCH KEY#
```

Listing Current Typing Aid Definitions

To list all current typing aid definitions, execute the following command:

```
LIST KEY#
```

Storing Typing Aid Definitions

You might determine, after operating your HP250 for a period of time, that there are several commands which you use repetitively throughout the course of a day. If this is the case, you can define typing aid softkeys to execute the commands and then save your definitions in a special type of HP250 file, known as a KEY file.

To save your softkey definitions, use the STORE KEY command; this saves all softkeys that are currently defined. The STORE KEY command is very similar to the STORE command described in Chapter 6; you specify the volume that you want to store the KEY file on.

For example, to store your softkey definitions onto a 7908 disc in a KEY file named STEVES, execute the following command:

```
STORE KEY "STEVES:0"
```

After doing this, you can execute the CATALOG command to see the file named STEVES.

NOTE

If you attempt to STORE a KEY file which already exists under the same name, you will get an Error 54. Use the RE-STORE command to correct this error.

Loading Typing Aid Key Files

Any KEY file created by the STORE command can be loaded into memory by executing the LOAD KEY command. This command is very similar to the LOAD command described in the chapter titled "System Commands".

For example, if you wanted to load the softkey definitions that you just stored onto the 7908 in the example above, execute:

```
LOAD KEY "STEVES:0"
```

Now that you understand all aspects of using softkeys as typing aids, read further to see some examples of how you can use them.

Examples

The following examples are presented to give you ideas on how to use softkeys as typing aids. There is an inexhaustible number of ways in which you can use softkeys as typing aids. What is shown here is, by no means, intended to cover all possible uses of softkeys as typing aids; rather, they are intended to give you specific examples while also encouraging you to think of ways in which you can use these keys to perform repetitive tasks.

Example 1

Suppose that your daily responsibilities require you to type something repeatedly. One such thing might be the date. You might have to type memos that repeatedly use this date. Rather than having to type the date over and over again, you can enter the date into a softkey, and then just press the softkey whenever you need the date. Here is a way to do this.

EDIT KEY 1 - UNDEFINED September 30,1981	1) TYPE "EDIT" and PRESS SOFTKEY #1
	2) TYPE IN THE DATE AND PRESS SOFTKEY #1

September 30,1981							
----------------------	--	--	--	--	--	--	--

Example 2

Suppose someone hands you a disc and says to you, "I want you to purge all of the data files on the mass storage device". If there is a large number of data files, you can save time and effort by defining a softkey as a typing aid to execute the PURGE command for you.

Here is how you would do it.

```
EDIT
KEY 1 - UNDEFINED
└PURGE"→→→→→"└
```

- 1) Type EDIT and press Softkey #1
- 2) Access the display control character set by pressing CNTL and Softkey #12
- 3) Type in the sequence as shown
 - a) Press INSERT
 - b) Type PURGE"
 - c) Press the right arrow key six times so that you space over the file name
 - d) Type a "
 - e) Press CONTROL CLEAR to clear the rest of the line
 - f) Press EXECUTE
- 4) Press Softkey #1 to define the typing-aid key

└PURGE"→							
→→→→→"└							

APPENDIX E

Error Messages

Operator errors often result from incorrect procedures, inappropriate commands, or commands with incorrect parameters. Software errors are caused by an error in a program being executed. There may be logical errors or inappropriate commands, or commands with incorrect parameters. Hardware errors result from hardware failures, absence, or malfunction. The error message numbers of the operating system and an appropriate description of each are listed below.

1. Software (DROM) configuration error: The necessary system software is not loaded into memory.
2. Memory overflow: Lack of available memory for the task at hand.
3. Line not found or not in current program segment: Specified line may have been deleted.
4. Improper RETURN: A RETURN statement is encountered and it has no prior GOSUB.
5. Abnormal program termination: Missing a STOP or END statement in a program. Or a FNEND statement is encountered before the RETURN.
6. Improper FOR-NEXT matching: A NEXT statement is encountered without a corresponding FOR. Also improper FOR-NEXT nesting.
7. Undefined function or subprogram: Misspelling the function or subprogram name. Calling a function or subprogram that isn't part of your program.
8. Improper parameter matching: Specifying inconsistent parameter lists in a CALL statement or user-defined function.
9. Improper number of parameters: Specifying the wrong number of parameters in a CALL statement or a user-defined function.
10. String value required: Returning wrong type of information from a function (when a string was expected, a number was sent).

Error Messages

11. Numeric value required: Returning wrong type of information from a function (when a number was expected, a string was sent).
 12. Attempt to re-declare a variable or file: Dimensioning or typing the same variable more than once or using the same file number twice.
 13. Array dimensions not specified: Attempting to access an array variable which has never been dimensioned or referenced.
 14. Incorrect OPTION BASE usage: More than one OPTION BASE statement in a program, or may have a dimension or declarative statement preceding OPTION BASE.
 15. Invalid variable bounds: Dimensioning an array in a subprogram where the lower bound is >32767 or <-32767.
 16. Dimensions are improper or inconsistent: Using an array variable with the wrong subscripts. Example: If A is a 5x7 array, you can't use A(4). Also, dimensioning an array of more than 32768 elements.
 17. Subscript out of range: Using an array element too large dimension-wise to be an element of the desired array.
 18. Substring out of range or substring too long: The maximum length of the receiving string is not dimensioned long enough or the subscripts of the string are incompatible with respect to the maximum or current length.
 19. Improper value: A parameter is out of range for a particular statement being used.
 20. Integer-precision overflow: The number specified as integer is out of the range -32768 thru 32767.*
 21. Short-precision overflow: The number specified as short precision is out of the range -9.99999E63 thru +9.99999E63.*
 22. Real-precision overflow: The number specified as real precision is out of the range -9.99999999999 thru 9.99999999999E99.*
- * These error messages indicate that DEFAULT mode isn't on. If DEFAULT is on, then the error messages will not appear and alternate default values will be assigned to the expressions although the result was out of range. The alternate or default values are either a maximum or minimum of the specified range, or +xxxx, as in error 24 or 26.

23. Intermediate-result overflow: The intermediate result was out of the range -9.999999999999999E511 thru 9.999999999999999E511.*
24. TAN (N*PI/2), when N is odd: the result is undefined.*
25. Argument of ASN or ACS is >1 in absolute value: Passing an argument to ASN or ACS which is >1 or <-1.
26. 0 to a negative power: Taking the value 0 to a negative power, which is the same as dividing by 0.*
27. Negative number to non-integral power: Taking a negative number to a fractional power. Example: (-16)**.5 would give a complex number.
28. Argument of LOG or LGT is negative: The result would give a complex number.
29. Argument of LOG or LGT is 0: Value is undefined.**
30. Argument of SQR is negative: The square root of a negative expression would give a complex value.
31. Division by 0, or modulo 0: Division by 0 is not allowed.
32. Improper string usage: Reading a numeric value in a READ statement, but a non-numeric string is being accessed in the data statement. For example:
- ```
10 READ X,Y
50 DATA "ABC",7
```
33. Argument of NUM, CHR\$, or RPT\$ is improper: The NUM parameter may be the null string or if the product of the number of characters to be repeated and the number of it is to be repeated exceeds 32767, the argument of RPT\$ ) is invalid.
34. Reference line is not an IMAGE statement: The PRINT USING or DISP USING statement references a line which is not an IMAGE statement.
35. Improper image: The characters in the string expression of a PRINT USING or DISP USING statement are not acceptable as an image.
- \*\* DEFAULT is not on if this error occurred. When DEFAULT is on then this expression is assigned a value of -xxxx.

## Error Messages

36. Out of data: Reading data using a READ statement when data has run out or does not exist.
37. Edit string too long: Attempting to work with a string longer than 160 characters with EDIT.
38. Syntax error in LENTER or ENTER: An invalid numeric or string expression has been accessed by an ENTER or LENTER statement, or a protected line has been accessed by LENTER.
39. Function subprogram not allowed: A DIM statement in a subprogram contains a user-definable function as a parameter.
40. Improper replace or delete: The last line exceeds 9999 in the REN or LOADSUB command, or a LOADSUB statement was replaced with a statement other than a SUB.
41. First line number > second line number: For example, in a DELETE, SAVE, LIST or SECURE statement, the first line number is larger than the second.
42. Attempt to replace or delete a busy line or subprogram: Attempting to modify a line that currently is required to continue program execution.
43. Matrix not square.
44. Illegal operand in matrix transposition or matrix multiplication.
45. Nested keyboard entry statements: When asked to input a value, another INPUT statement has been executed via a subprogram or ON KEY# routine.
46. (RE-)STORE, (RE-)SAVE (RE-)STORE KEYS, or (RE-)STORE BIN error: Attempting to store information that is not currently in memory.
47. Subprogram COM declaration is not consistent with main program: The initial common statement is not consistent with the variable list of the COM statement in the subprogram.
48. Recursion in single-line function: Single lined function has been defined in terms of itself.

Example: 90 DEF FNA (X)=FNA(X)\*8

49. Line specified in ON declaration not found: Transferring to a specific line through a statement, such as ON KEY, ON END, ON ERROR, or ON HALT, and the line does not exist in the current operating environment.
50. File number out of range: Referencing a file number outside the range of 1 thru 10.
51. File not currently assigned: Attempting to access a file that is not currently ASSIGNED.
52. Improper volume label or mass storage unit specifier: Improper syntax for device specifier or volume label longer than eight characters.
53. Improper file name: A file name contains invalid characters, is the null string, or is greater than six characters.
54. Duplicate file name: Attempting to use the same name for two files on same medium.
55. Directory overflow: There is not enough room in the directory to incorporate additional files, or the availability table is full when purging a file.
56. File name is undefined: The specified file name does not exist on the specified device.
57. Attempt to use device of unknown type for mass storage: Haven't loaded the necessary system software (DROM) or binary program to be used by the system to control a special device.
58. Improper file type: Attempting to LOAD a file that is not a program type, or GET a file that is not a data type, or ASSIGN a nondata file. Must use LINK or GET in order to load data files as programs.
59. End of file found: Attempting to retrieve or record information beyond the end of the file in, for example, a PRINT# or READ# statement.
60. End of record found in random mode: Attempting to retrieve or record information beyond the end of the record using direct data access.
61. Defined record size too small: Attempting to store data in a record which is too small.

## Error Messages

62. File is protected, or wrong protect code specified: Attempting to modify or purge a protected file with the wrong protect code, or attempting to PROTECT a file that is already protected.
63. Number of records, bytes/record, or physical sectors too large: Cannot exceed 65534.
64. Medium overflow: There is not enough contiguous space on the medium to store desired information.
65. Incorrect data type: Attempting to read a string value into a numeric or vice versa.
66. Unused
67. Parameter is  $\leq 0$  (when rounded): The parameter is an ASSIGN statement, for example, is less than 1.
68. Invalid line number encountered in mass storage operation: The program line access by MERGE, GET, or LINK exceeds 9999 after executing any renumbering parameter.
- 69 - 76 Unused
77. Specified label not found: Medium having the specified label not found.
78. Possible volume-label conflict: Operation performed, however, the drive door was opened between when volume label was identified with drive, and this operation.
79. LOAD SUB error: A requested subprogram segment is not present or binaries are present in the program file.
80. Mass storage device door open or medium has been removed: Data transfer cannot occur if medium is not inserted correctly with door closed.
81. Mass storage device failure
82. Mass storage device not present: The device address has been specified for a storage medium that is not hooked up to the system or not present at all.
83. Mass storage device is write-protected: Attempting to store data on a device from which data can only be retrieved.

84. Record not found: Addressed (requested) a record not available on that volume.
85. Mass storage medium is not initialized: Blank discs, fixed or flexible, must be initialized before use.
86. Special media: Cannot be accessed via standard mass storage operations.
87. Record address error: The disc medium has been damaged. The medium should be discarded or re-initialized after attempting to recover data.
88. Read data error: May indicate a medium failure due to defective disc or controller.
89. Check read error. Inconsistency between the data written on a medium and the version in memory. Attempt to repeat the operation.
90. Mass storage system error: A mass storage failure - call HP for service.
91. Attempt to access a busy file: I/O operations are nested on duplicate file numbers.
92. Can't get exclusive access to a specified file: Attempting to get exclusive access to a file, for example, thru PURGE, that is currently being accessed by yourself or someone else.
93. Attempt to access an exclusive file: Attempting to access a file when someone else has exclusive access.
94. Specified file cannot currently be locked: A file is already locked by another console.
95. String not intact on file: There is an improper character count encountered during READ# into a string variable.
96. Program is run-only: Cannot be RENAMEd, COPYed, etc.
97. Unexpected Disc Interrupt - data files closed: Normally, the door was opened while files were opened.
98. Unexpected Disc Interrupt - Data lost: The door was opened and some data on at least one file is lost.
99. Unexpected Disc Interrupt - Opening a door on a mass storage device which has been locked via the program (doesn't apply to flexible disc drives).



## Error Messages

- 100. IMAGE specification expects a numeric item: The expression to be output in PRINT USING or DISP USING is a string, but the corresponding IMAGE specification is numeric.
- 101. IMAGE specification expects a string item: The expression to be output in PRINT USING or DISP USING is numeric, but the corresponding IMAGE specification is string.
- 102. Numeric field specification is larger than internal buffer size: An output field larger than the available buffer space of the system is specified.
- 103. Not enough IMAGE specifications: An item in the PRINT USING or DISP USING statement has no corresponding IMAGE specification.
- 104 - 119 Unused
- 120. Output field overflow: A string or a numerical expression is too large to fit into an output field.
- 121. Improper value in CURSOR parameter.
- 122 - 129 Unused
- 130. Parameter for REQUEST OR RELEASE out of range: The parameter is not an integer from 0 thru 7.
- 131. Specified device not available: The device is already being used by another console.
- 132. Referenced device missing or wrong type: A device is being requested which isn't present, or that the requested device is not a printer.
- 133. Printer is down: Printer is either turned off or no longer connected to the system. Turn on or re-connect.
- 134. Printer is offline: The cover is off the printer or the printer is offline and not available for printing.
- 135 - 139 Unused
- 140. Spool file record length must be 256 bytes: An existing data file has been spooled to, but its record length is less than 256 bytes.
- 141. Incorrect data type found in spool file: Attempting to spool using a file that contains non-string data.

- 142. Door open - spool operation aborted: The disc drive door was opened during a spool operation. The current file is intact, but the last segment of data may be lost.
- 143. Expansion of spool file would cause medium overflow: There isn't enough contiguous space on the medium being accessed to expand the spool file. Spool operation is aborted; file is left intact.
- 144. Spool file size too small: The file being spooled to has less than five records.
- 145 - 149 Unused
- 150. Type of expression in CASE does not match type of expression in SELECT.
- 151. Parameter out of range on INDENT.
- 152. Improper matching of structured construct.
- 153. No structured construct active.
- 155. Invalid statement specified in COMMAND.
- 156. More than one level of recursion not allowed in COMMAND.
- 157 - 159 Unused.
- 160. Tape Operation Pending: The referenced tape was removed from the drive before the proper updating could take place. Insert the tape into the drive it was removed from and allow it to update properly before removal.
- 161. Disc Buffer Pending: The buffer required for this operation holds data for a tape that was prematurely removed. Locate the proper tape, insert it into the drive, and let the normal procedure complete before its removal.
- 162. Buffer Disc Not Ready: The disc holding the buffer for this tape is not ready for use.
- 163. Tape door locked.
- 164. Writing to tape not allowed until tape is initialized.
- 165. Self-test failure on Disc.
- 166 - 199 Unused.

## **PACK/250 Errors**

- 200. Referenced line not a PACKFMT.
- 201. Unused.
- 202. Insufficient dimension length in PACK statement, or insufficient current length in an UNPACK.
- 203. List item >32K in PACK or UNPACK.
- 204. Conversion error.
- 205. UNPACK requires a source string of greater current length.

## **IMAGE/250 Errors**

- 210. Bad status array.
- 211. No DBASE IS statement active; improper data base specified or data base is not open.
- 212. Specified data set not found.
- 213. Too many variables in list.
- 214. IN DATA SET already active for data set.
- 215. Number of elements does not match.
- 216. Variable type does not match with associated field in set.
- 217. String length in list insufficient, or length of list array >255 bytes.
- 218. Variable not in common.
- 219. Line referenced is not an IN DATA SET LIST statement.
- 220. Improper or illegal use of maintenance word.
- 221. Data set not created.
- 222. Needed volume lost during dismount.
- 223. Improper backup file.

- 224. Incomplete backup file.
- 225. Improper utility version number in root file.
- 226. Corrupt data base - must recreate it.
- 227. Corrupt data base - must erase it in its entirety.
- 228. Data Sets cannot be restored without a root file.
- 229. No volume name on data base or backup volume.
- 320. Set or item specifier is out of range or is an invalid set or item name.
- 321. Relational operator is invalid.
- 322. The predicate specifier is not a valid form.

## **SORT/250 Errors**

- 230. Improper nesting of SORT statements, including DATA BASE IS and IN DATA SET.
- 231. Cannot reactivate workfile.
- 232. Data base mode improper for sort.
- 233. Required data set or root file not mounted.
- 234. Missing or improper set linkage.
- 235. No WORKFILE IS # statement active.
- 236. Improper data item or data item not found.
- 237. Sum of sort field lengths plus overhead exceeds 256 bytes in SORT BY.
- 238. Improper synthetic linkage.
- 239. Insufficient space in workfile.
- 240. Program lost due to disc failure.
- 241. Improper operation attempted on workfile.

## Error Messages

- 242. Improper READ# or PRINT# on workfile.
- 243. Workfile contains invalid information.
- 244. Data Base Corrupt.

## REPORT WRITER/250 Errors

- 250. BEGIN REPORT does not reference a REPORT HEADER statement.
- 251. Report Writer is already active.
- 252. An END REPORT DESCRIPTION statement is missing as terminator to the Report Description section.
- 253. Duplicate Report Writer Description section.
- 254. Blank lines in PAGE LENGTH statement is greater than page size, or is negative.
- 255. Expression in a Report Writer statement evaluates to an unacceptable value.
- 256. A TOTALS ON or GRAND TOTALS ON statement is improperly positioned in the Report Description section.
- 257. A Report Writer operation was requested while outside the program scope of an active Report Writer, or an END REPORT was not executed for an active Report Writer before subprogram termination.
- 258. Effective page size is less than three lines.
- 259. Illegal execution of a Report Description section statement.
- 260. Insufficient space for printed output within the current page.
- 261. Left margin specified is less than 1 or greater than current printer width.
- 262. Control variable in BREAK WHEN statement has a length greater than was initially allocated.
- 263. A DETAIL LINE statement may not appear within the Report Description section.

- 264. Level parameter is out of range of from 0 thru 9.
- 265. (GRAND) TOTALS ON statement is not active for the level requested.
- 266. Sequence parameter is out of range for (GRAND) TOTALS ON statement at the level requested.
- 267. WITH number LINES parameter in a header, trailer, or detail line is greater than the effective page size or is negative.
- 268. OLDCV(\$) function references a level which does not have a break defined.
- 269. OLDCV(\$) function does not match the data type for the control variable in the BREAK WHEN statement at the level requested.
- 270. PRINTER IS statement may not be executed while Report Writer is active.
- 271. A Report Writer statement may not be used recursively.
- 280. Language cannot be changed during SORT BY.

## **FORMS/250 Errors**

- 290. Not allowed when form is active.
- 291. Not allowed within form image.
- 292. Attempt to input after last field of form.
- 293. Attempt to output after last field of form.
- 294. Not allowed unless form is active.

## **TIMER/250 Errors**

- 300. Date not in acceptable format or incorrect.
- 301. Time not in acceptable format or incorrect.
- 302. Date or time has already been set. It may be set only once per system boot-up.
- 303. ON DELAY value incorrect.

## **T10/250 Errors**

- 310. Port ordinal out of range of from 11 thru 15.
- 311. Priority value out of range from 1 thru 15.
- 312. Invalid address in ON...interrupt statement.
- 314. Ownership error: must do REQUEST before ON INPUT.
- 315. No input available: cannot do AREAD\$ from specified port.
- 316. Invalid SEND or SEND BREAK statement: specified device is not a computer.

## **MEDIA/250 Errors**

### **General MEDIA Errors**

- 340. Operation only allowed on IBM media.
- 341. Improper operation on CHAR file.
- 342. Operation not allowed on this media.
- 343. Invalid IBM data set record length.
- 344. File on IBM media must be type CHAR.
- 345. Invalid IBM file start address in CREATE command.

## IBMDUMP and IBMWREC Errors

- 370. Record number out of range for IBM media.
- 371. Device does not contain IBM format media.
- 372. Invalid display or conversion parameter.
- 373. Deleted record read.

## TASK/250 Errors

The error codes have different meanings for the REQUEST command and the ATTACH command. The error numbers in the table are execution errors caused by unsuccessful commands with no optional result parameter. The result in the table is the returned status indicating the outcome of the command.

### REQUEST# Command

| Error Number | Result | Description                                                            |
|--------------|--------|------------------------------------------------------------------------|
| none         | 0      | Ownership granted                                                      |
| 401          | 1      | Specified TASKID not a task                                            |
| 402          | 2      | Specified TASKID not a secondary task or already owned by another user |
| 403          | 3      | Executing task not the home user of a workstation                      |

### ATTACH Command

| Error Number | Result | Description                                                                                                 |
|--------------|--------|-------------------------------------------------------------------------------------------------------------|
| none         | 0      | Attach initiated                                                                                            |
| 401          | 1      | Specified TASKID not a task                                                                                 |
| 402          | 2      | Specified TASKID not owned by executing task                                                                |
| 403          | 3      | Executing task not the home user of a workstation or executing task currently not attached to a workstation |

## Binary Program Errors

- 800 Source and destination must not be the same device
- 801 Devices not compatible
- 802 Destination device is too small



## Error Messages

- 803 Cannot duplicate media
- 810 Protect code parameter must be 2 characters long.
- 850 Bad file-type specifier
- 851 Files not similar
- 860 Old password does not match
- 861 Improper number of array elements.
- 999 Binary program not compatible with current operating system revision.

## System Errors

- 1000. System Files table full; There are too many active files in the system.
- 1001. Too many accesses to specified file: There are more than 15 concurrent addresses to the same file. Must de-assign some mass memory files.
- 1002. Request would result in deadlock: You are requesting a resource that, if granted, would deadlock the system.
- 1003. Cannot get exclusive access to specified device.
- 1004. Keyword not recognized by this operating system revision.
- 1005. Memory overflow in common block.
- 1010. Memory parity error: Hardware failure in memory. May be a temporary condition. If error reoccurs, record the numbers following the error number on the display, and contact HP for assistance.

Some system malfunctions are denoted by an error-like message on the display. These messages will appear as the words "SYSTEM ERROR". In addition, a table of numbers is listed. If a condition of this type occurs, you should record the system error letter and the message and table shown on the display. You must power off the system and then power it up after these errors.

## Loader Errors

LOADER ERROR messages indicate that the operating system cannot be loaded successfully:

- A Checksum error.
- B Disc read error.
- C Checkread error.
- D Insufficient memory.
- E Interface error.
- F Disc or system error.

Loader errors A thru C may indicate that the operating system disc or tape is worn or damaged. Try loading the system with the backup (spare) copy of the operating system disc or tape. If any loader error persists after repeated tries, record the error message and call HP for Service.

## Configuration Messages

These messages indicate an inconsistency in hardware/operating system configuration. Although the system can operate with inconsistencies, each should be corrected as soon as possible. Contact your software supplier for assistance.

MEMORY FAILURE - BLOCK nn,...

Either the operating system expected more memory than available or a memory block has failed.

UNEXPECTED MEMORY PRESENT - BLOCK nn,... USER GIVEN EXTRA MEMORY

More memory is available than expected by the operating system.

ASYNC DATA COMM BOARD ON PA n IS DOWN

The self-test for the data communications interface has failed. Call HP for service.



Manual Part No. 45260-90002 E1281  
Printed in U.S.A.  
November 1981

