

PDP 6

INSTALLATION MANUAL

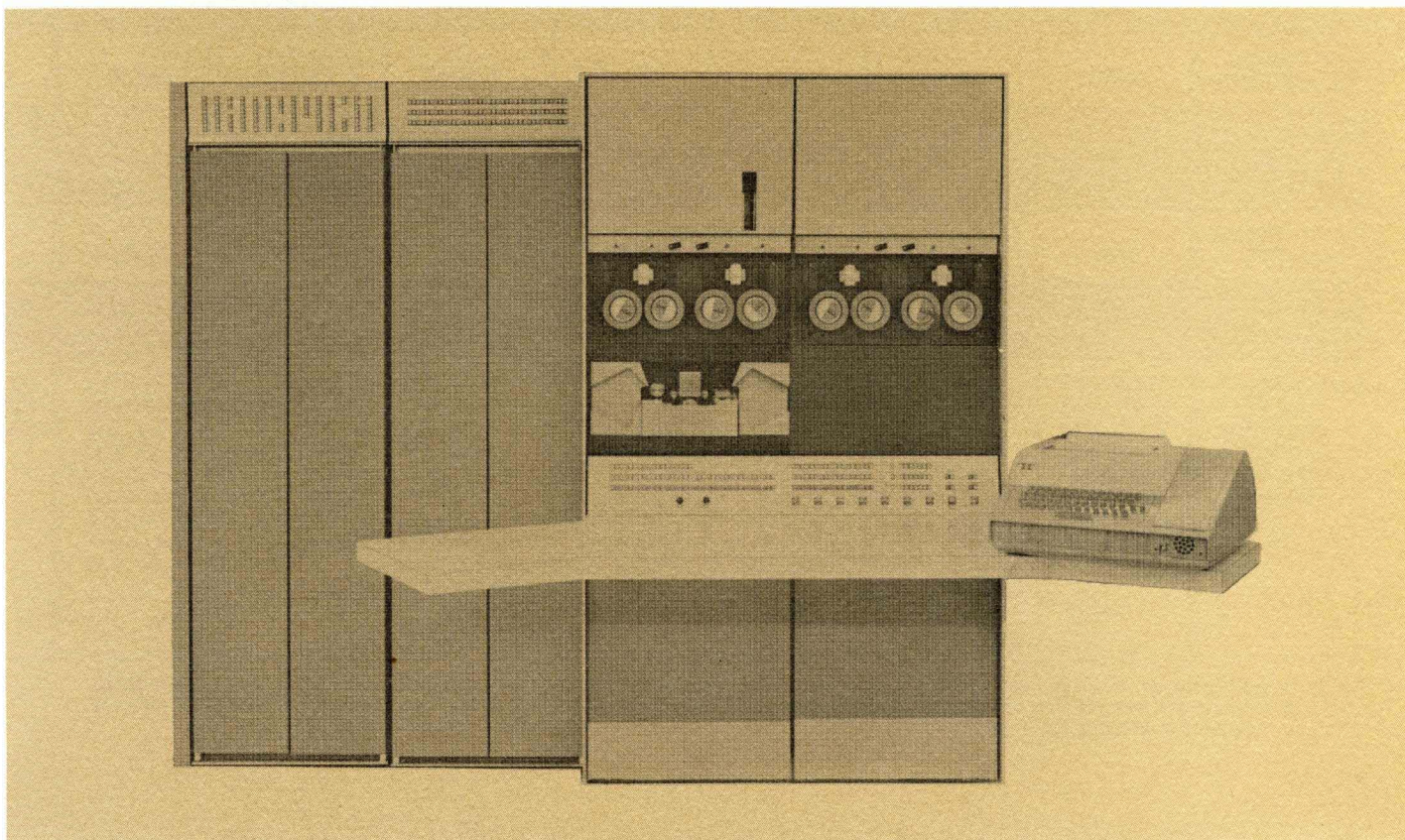

DIGITAL EQUIPMENT CORPORATION

PHYSICAL CHARACTERISTICS

The PDP-6 Programmed Data Processor is a high-speed, stored-program, digital computer constructed of modular solid-state circuits. Each PDP-6 is tailor-made to specific customer needs by selecting the proper equipment from a list of central processor and input-output options. A typical system installation could include one or more of the units described below. In most cases system units are housed in standard Digital cabinets. However, some pieces of equipment,

especially those that require writing surfaces or tables for accessory equipment, have specially designed cabinets; others which require only one or two racks of cabinet space are mounted in existing cabinets whenever possible. Note that dimensions in the table are for complete units, standing alone. If desired, standard cabinets may be attached to one another by removing end panels. Over-all dimensions are then reduced by the width of the removed panels ($1\frac{1}{4}$ inches per side); weight is reduced by 45 pounds per panel.

	ARITHMETIC PROCESSOR 166	FAST MEMORY 162	5 μ SEC CORE MEMORY 161	2 μ SEC CORE MEMORY 163 B/C	INCREMENTAL CRT DISPLAY 346	CARD PUNCH 460A	CARD PUNCH 460B	CARD READER 461A
Weight (lb)	1300	400	800	800	700	910	1525	200
Dimensions (in.)								
Width	81 $\frac{1}{2}$	22 $\frac{1}{4}$	42	42	42	44 $\frac{1}{2}$	73	30
Depth	44 $\frac{1}{8}$	27 $\frac{1}{16}$	27 $\frac{1}{16}$	27 $\frac{1}{16}$	51	28	27 $\frac{1}{2}$	17
Height	69 $\frac{1}{8}$	69 $\frac{1}{8}$	69 $\frac{1}{8}$	69 $\frac{1}{8}$	69 $\frac{1}{8}$	53	47	50
Service Clearance (in.)						See Comment	See Comment	
Front	66	8 $\frac{3}{4}$	8 $\frac{3}{4}$	8 $\frac{3}{4}$	8 $\frac{3}{4}$	36	36	—
Rear	14 $\frac{1}{8}$	14 $\frac{1}{8}$	14 $\frac{1}{8}$	14 $\frac{1}{8}$	36	36	36	6 $\frac{1}{8}$
Heat Dissipa- tion (Btu/hr)	9900	2150	3300	4950	5900	9420	9420	495
Current (A)								
Nominal	25	5.5	8.5	13	15	22	22	1.3
Surge	40	8	10	17	20	—	—	7
Power Dissipa- tion (KW)	2.9	0.635	0.98	1.5	1.73	2.75	2.75	0.145
Standard Cabinets	4	1	2	2	2	0; See note 1	0; See note 1	0; See note 1
Comments	Table protrudes 35 in. front, 18 in. right hand side. Clearance is included above.	16 words 0.4 μ sec complete cycle.	16,384 words of 36 bits.	16,384 words of 36 bits.	Table protrudes 19 $\frac{1}{2}$ in. in front. Type 346 includes incremental display and vector gen- erator.	Side clearance 36 in. each side. Speed, 100 cards per minute.	Side clearance 36 in. each side. Speed, 300 cards per minute.	Speed, 200 cards per minute

- Notes: 1. Additional control logic, consisting of one or two racks, is normally mounted in existing cabinets when space is available.
2. Dimensions include size and weight of one standard cabinet. This cabinet is not required if space for four to six racks is available in existing cabinets.

ENVIRONMENTAL REQUIREMENTS

The central processor and input-output devices operate satisfactorily under ordinary conditions of humidity, shock, and vibration in a 50 to 105°F temperature range. However, a 70 to 85°F temperature range and a 30% to 80% humidity range are recommended. Consult the system heat characteristics that follow in planning room air conditioning if required.

POWER REQUIREMENTS

Each unit of the PDP-6 system requires a separate source of 105- to 125-volt, 60-cycle, single-phase power. On special request, all equipment can be factory wired for 50-cycle and/or 220- to 250-volt power. The power source must maintain the nominal voltage within $\pm 10\%$ under normal and transient load conditions. The electrical characteristics of individual units appear in the table below.

CARD READER 461B	LINE PRINTER 646	LINE PRINTER 680	DATA CONTROL 136	MICROTAPE CONTROL 551	DUAL MICROTAPE TRANSPORT 555	MAGNETIC TAPE CONTROL 516	MAGNETIC TAPE TRANSPORT 50	MAGNETIC TAPE TRANSPORT 570
750	1350	1500	233	255	65	281	600	850
48 29 50	56 30 $\frac{1}{4}$ 52 to 57	56 30 $\frac{1}{4}$ 52 to 57	22 $\frac{1}{4}$ 27 $\frac{1}{16}$ 69 $\frac{1}{8}$	22 $\frac{1}{4}$ 27 $\frac{1}{16}$ 69 $\frac{1}{8}$	19 17 $\frac{1}{2}$ 12	22 $\frac{1}{4}$ 27 $\frac{1}{16}$ 69 $\frac{1}{8}$	22 $\frac{1}{4}$ 27 $\frac{1}{16}$ 69 $\frac{1}{8}$	32 $\frac{1}{8}$ 32 $\frac{3}{8}$ 68
36	See Comment 24 26	See Comment 24 26	8 $\frac{3}{4}$ 14 $\frac{3}{8}$	8 $\frac{3}{4}$ 14 $\frac{3}{8}$	2 $\frac{1}{4}$ —	8 $\frac{3}{4}$ 14 $\frac{3}{8}$	18 $\frac{5}{16}$ 14 $\frac{3}{8}$	18 $\frac{3}{8}$ 14 $\frac{3}{8}$
4950	2710	3210	1200	1200	585	1564	2114	9800
13 —	13 —	17.4 —	3 5	3 5	1.5 3.2	4 6	8 12	25 —
1.45	1.56	2.06	0.345	0.345	0.172	0.460	0.62	2.9
0; See note 1	0; See note 1	0; See note 1	1; See note 2	1; See note 2	—	1; See note 2	1	—
Speed, 800 cards per minute.	Side clearance, 26 in. left, 30 in. right. Speed, 300 or 600 lines per minute.	Side clearance, 26 in. left, 30 in. right. Speed, 1000 lines per minute.	Controls up to six devices including two Type 551's and two Type 516's.	Controls up to four Type 555 Dual Microtape Transports. Requires Type 136.	Mounts in standard cabinet or on Type 166 Processor Console. Requires Type 551 and Type 136.	Type 136 and one of Types 520, 521, or 522 Interface Logic required. Controls up to eight Digital or IBM transports.	Requires Type 516 with Type 520 Interface and Type 136.	Requires Type 516 with Type 521 Interface and Type 136.

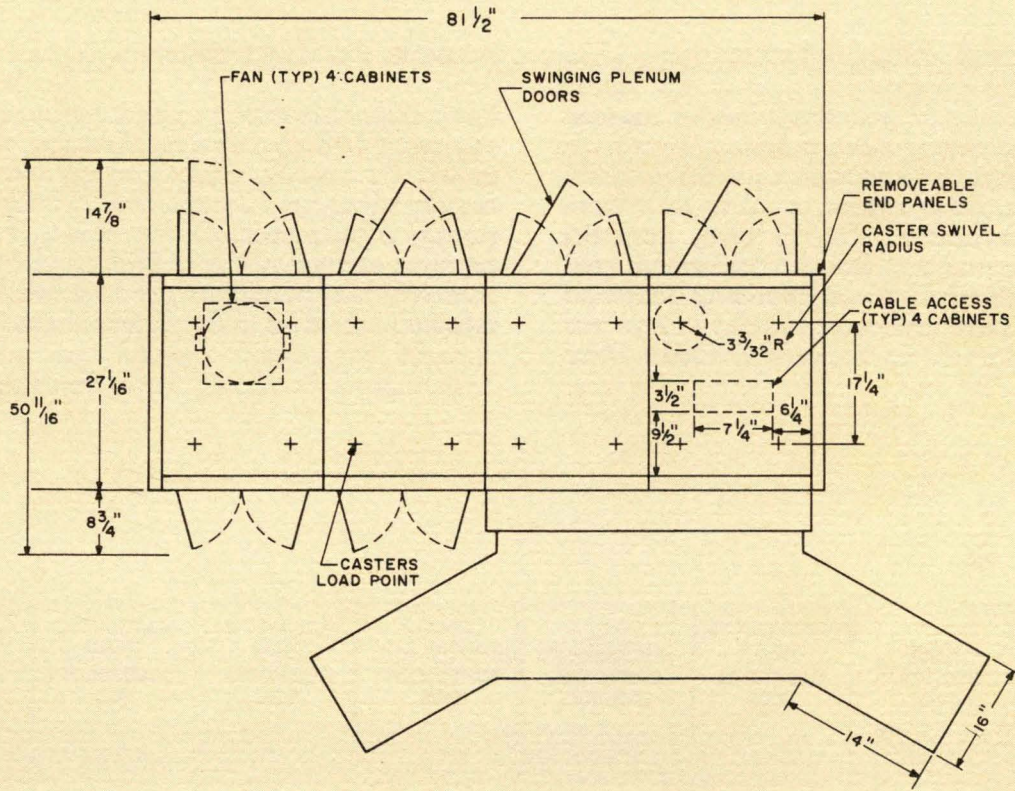

Arithmetic Processor Type 162

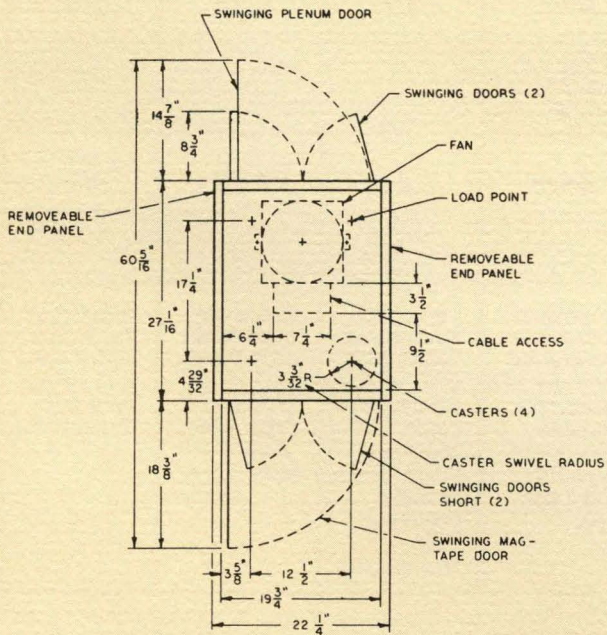

Standard Computer Cabinet

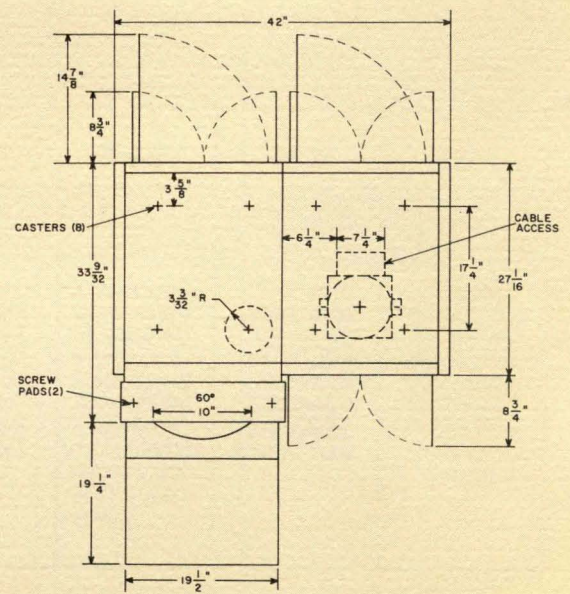

Incremental CRT Display Type 346

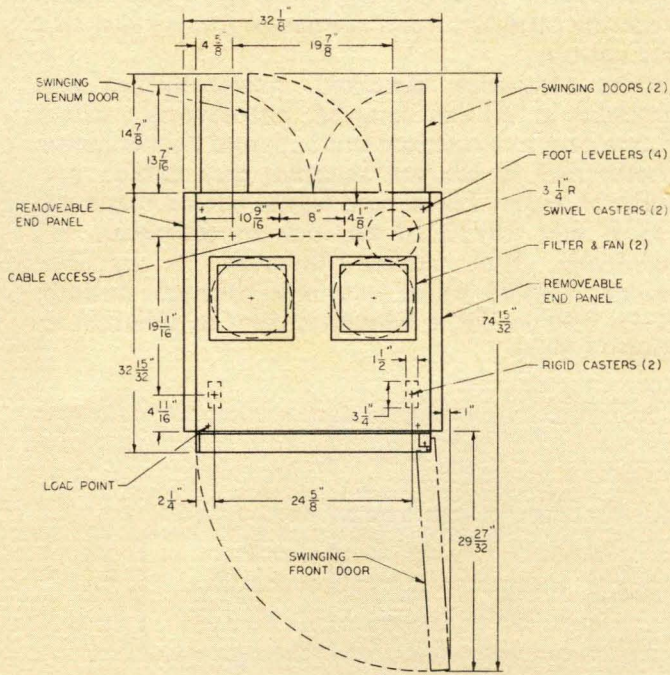

Magnetic Tape Transport Type 570

Plan views are scaled at 1/2 inch per foot. The outlines of the various units may be traced in any desired arrangement to plan the installation layout.

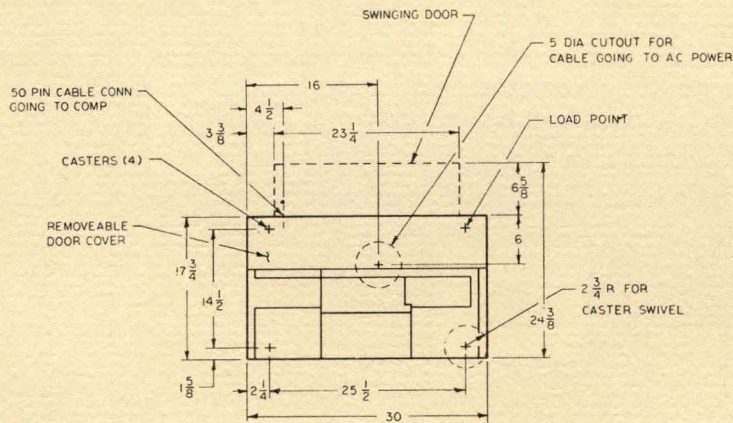

Card Reader Type 461A

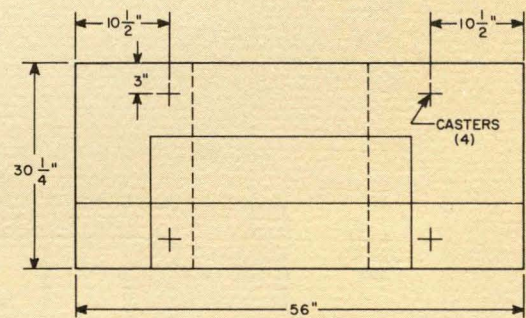

Line Printer Type 646

CABLING REQUIREMENTS

All system power sources must be provided with 115-volt, 30-amp, Hubbel Twistlock, flush receptacles (or their equivalent) to mate with input-output equipment power cables.

Fifty-wire shielded signal cables with Amphenol 115-114P male connectors at both ends interconnect input-output equipment and input-output control units. Any special equipment used with the system must have Amphenol 115-114S female connectors and 1391 shells to accept signal cables.

The central processor and input-output control units are interconnected by four 18-conductor,

coaxial cables. Bus cables have Amphenol 1-900-309 female connectors at both ends. Special input-output controls must be equipped with Methode MD6225 male connectors to receive the bus cables.

Unless otherwise specified, power cables are supplied in 20-foot lengths, permanently wired at one end to individual units. Signal cables come unattached in 25-foot lengths; bus cables are made to order. Power and signal cables measure 11/16 and 13/16 of an inch in diameter, respectively. Bus cables measure 1/8 by 2 5/8 inches. Cables enter cabinets through bottom ports. Cabling for a typical system installation is shown below.

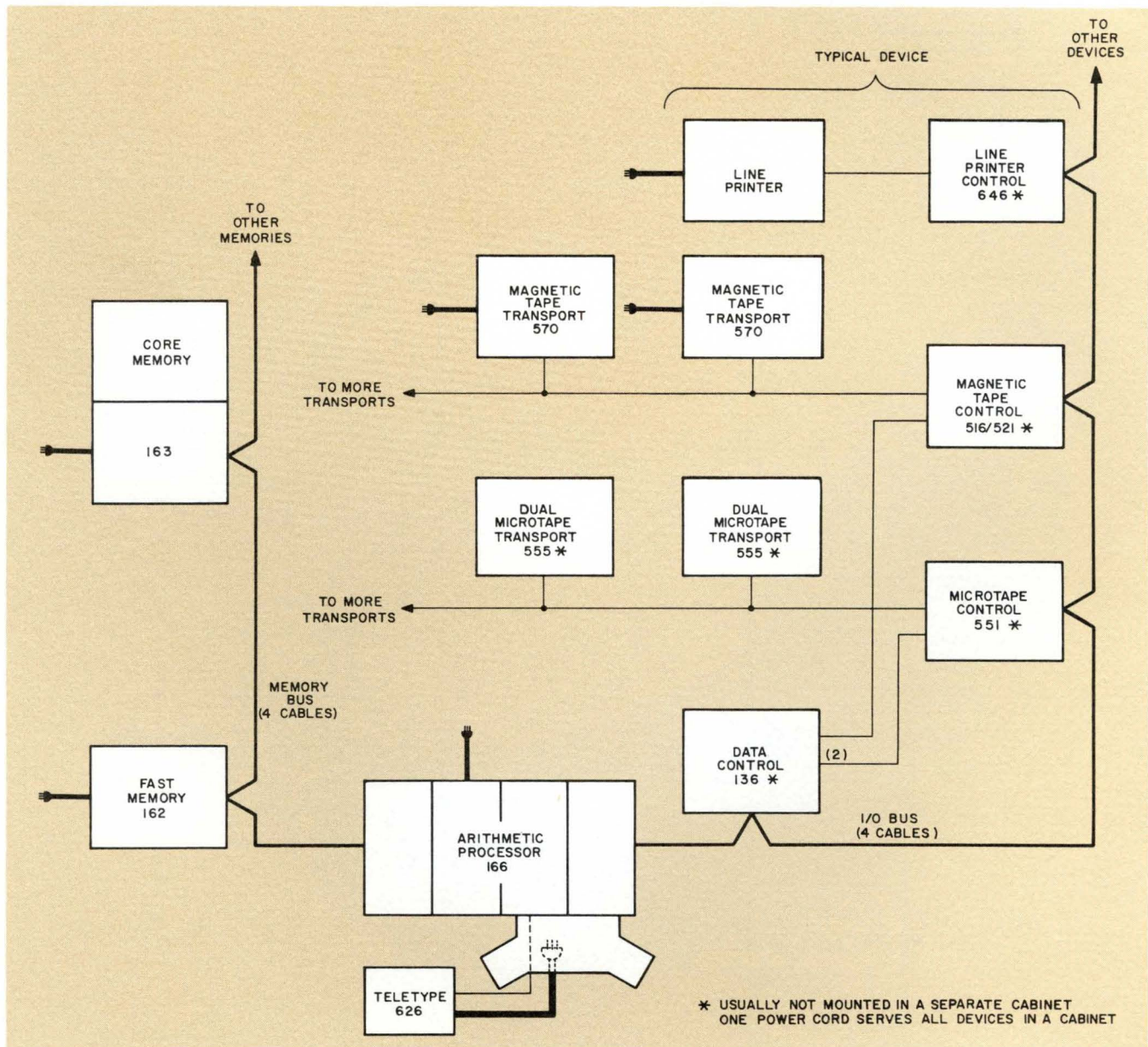

DIGITAL'S SERVICE POLICY

Digital's reputation for reliability owes a great deal to rigid quality control and customer field service. Before delivery all Digital products are thoroughly tested by trained check-out teams. Each module and every piece of accessory equipment is subjected to rigorous tests, many of them conducted by specially designed, automatic check-out devices. Computers and special systems are checked electrically and logically by numerous programmed routines.

During system checkout, customers are invited to visit the Maynard manufacturing facility to inspect and become familiar with the equipment. Computer customers may also send personnel to free instruction courses in computer operation and maintenance either in Maynard or at the Los Angeles sales office.

Digital's engineers are available during installation and test for assistance or consultation. Further technical assistance in the field is provided by home office design engineers or branch office application engineers in New York, Washington, Pittsburgh, Chicago, Los Angeles, San Francisco, Ottawa, Sydney (Australia), Reading (U. K.), and Munich.

digital

**EQUIPMENT
CORPORATION**

MAYNARD, MASSACHUSETTS

Los Angeles • Palo Alto • Pittsburgh
Washington, D. C. • Parsippany, N. J.
Chicago • Ann Arbor, Mich. • Carleton
Place, Ontario • Munich, Germany
Reading, England • Sydney, Australia