

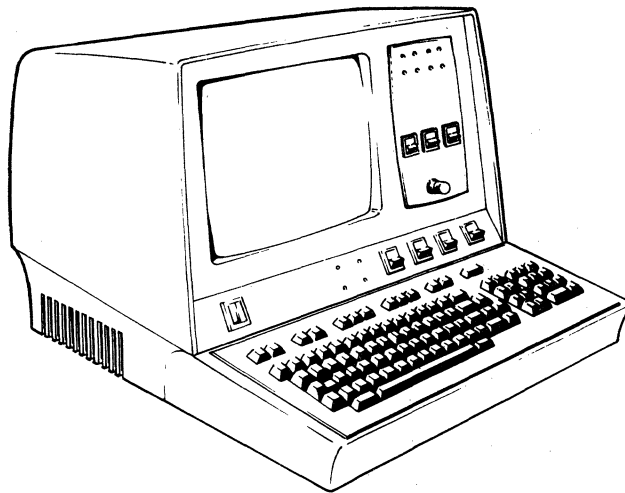

CDC® 751-10 TERMINAL SUBSYSTEM



VOLUME 2 OF 2
Installation and Checkout
Maintenance

HARDWARE MAINTENANCE MANUAL



LIST OF EFFECTIVE PAGES

New features, as well as changes, deletions, and additions to information in this manual are indicated by bars in the margins or by a dot near the page number if the entire page is affected. A bar by the page number indicates pagination rather than content has changed.

PAGE	REV	PAGE	REV	PAGE	REV
Front Cover					
Volume 2	-	3-22/3-23	B	6B-79 thru 6B-87	B
Title Page	-	3-24	A	6B-88	F
Updates (deleted)		3-25/3-26	F	6B-89/6B-90	B
v/vi	F	3-26.1/3-26.2	F	6B-91	C
vii/viii (deleted)		3-27	C	6B-92 thru 6B-101	B
ix/x	D	3-28 thru 3-30	A	Divider	-
xi	F	6-1 thru 6-6	A	6C-1/6C-2	C
xii thru xiv	C	6-7/6-8	C	6C-3 thru 6C-5	A
xv	D	6-9 thru 6-14	A	6C-6/6C-7	F
xvi	F	6-15/6-16	B	6C-8 thru 6C-20	A
xvii thru xx	C	6-17	C	6C-21/6C-22	F
3-1/3-2	C	6-18	A	Divider	-
3-3	A	6-19/6-20	B	6D-1	F
3-4/3-5	C	6-21		6D-2 thru 6D-15	C
3-6	A	Divider	-	6D-16	A
3-7	F	6A-1/6A-2	C	6D-17/6D-18	C
3-8	C	6A-3 thru 6A-5	A	6D-19/6D-20	A
3-9	A	Divider	-	6D-21	C
3-10	C	6B-1	F	6D-22/6D-23	A
3-11	F	6B-2 thru 6B-19	B	6D-24 thru 6D-27	C
3-12	A	6B-20/6B-21	F	6D-28 thru 6D-32	A
3-13	F	6B-22 thru 6B-74	B	6D-33 thru 6D-35	C
3-14 thru 3-16	A	6B-75	C	Divider	-
3-17 thru 3-20	B	6B-76	B	6E-1/6E-2	C
3-21	A	6B-77/6B-78	F	6E-3 thru 6E-21	A

LIST OF EFFECTIVE PAGES (CONTD)

PAGE	REV
Divider	-
Index 6-23 thru Index 6-27	C
E-1 thru E-45	D
F-1 thru F-5	D
Comment Sheet	F
Mailer	-
Back Cover	-

PAGE	REV

PAGE	REV

PREFACE

This two-volume manual assists those performing on-site maintenance of the CDC 751-10 Terminal Subsystem. This volume (volume 2) provides installation, checkout, and detailed maintenance information for the terminal subsystem.* Refer to the preface of volume 1 for further definition of both volumes of this manual and of the subsystem.

* Information is provided for installation, checkout and maintenance of the 70-LPM Impact Printer. Appendix D (Vol. 1 of this manual) contains general description and specification information. Appendix E (Vol. 2) has installation-checkout and maintenance procedures for the 70-LPM Printer. Appendix F has information about printer supplies and format tape punching.



CONTENTS

<u>Section</u>		<u>Page</u>
3	— INSTALLATION AND CHECKOUT	
	Crating	3-1
	Uncrating	3-8
	Keyboard Display	3-8
	Nonimpact Printer	3-8
	Impact Printer	3-8
	Tape Cassette Unit	3-9
	Circuit Card Modules	3-9
	Miscellaneous Subassemblies	3-10
	Installation and Checkout	3-10
	Keyboard Display Installation	3-11
	Keyboard Display Checkout	3-14
	Installing Supplemental Function Modules	3-17
	Checking Supplemental Function Modules	3-17
	Extended Display Memory	3-18
	Highlight	3-18
	Edit	3-19
	Answerback	3-19
	Multidrop	3-20
	Current Loop System Interface	3-21
	Printer Interface Control	3-21
	Tape Cassette Unit Interface Control	3-22
	+5-V Regulator Slave	3-23
	Paging	3-24
	Nonimpact Printer Installation	3-24
	Nonimpact Printer Checkout	3-25
	Impact Printer Installation	3-26.1
	Impact Printer Checkout	3-27
	Tape Cassette Unit Installation	3-28
	Tape Cassette Unit Checkout	3-29
	Complete Terminal Subsystem Installation Checkout	3-30
6	— MAINTENANCE	
	Emergency Maintenance	6-1
	Preventive Maintenance	6-2
	Keyboard Display PMTs	6-2
	Keyboard Display PMTPs	6-3

Section

Page

Nonimpact Printer PMTs	6-4
Nonimpact Printer PMTPs	6-5
Impact Printer PMTs	6-7
Impact Printer PMTPs	6-8
Tape Cassette Unit PMTs	6-11
Tape Cassette Unit PMTPs	6-12
Maintenance Aids	6-13
Diagnostic and Corrective Maintenance	6-13
Subsystem Test Mode Diagnostic	6-14
Impact Printer Test Print Diagnostic	6-16
Diagnostic Tables	6-16
Conditions	6-18
Situations	6-18
Actions	6-18
Sequence of Actions	6-19
General Instructions	6-19
Arrangement of Diagnostic and Corrective Maintenance	
Information	6-21
Procedure TS1 — Turning On Subsystem Power	6A-2
Procedure TS2 — Turning Off Subsystem Power	6A-3
Procedure TS3 — Removing/Replacing Subsystem	
Cables	6A-4
Procedure TS4 — Checking Subsystem Cables	6A-4
Procedure TS5 — Removing/Replacing Subsystem	
Cabinets	6A-5
Procedure CRT1 — Turning On Keyboard Display	
Power	6B-19
Procedure CRT2 — Turning Off Keyboard Display	
Power	6B-19
Procedure CRT3 — Replacing High-Voltage	
Transformer	6B-20
Procedure CRT4 — Replacing Video Module +16-V dc	
Regulators	6B-22
Procedure CRT5 — Replacing Display Terminal AC	
Entry Panel	6B-24
Procedure CRT6 — Replacing Display Terminal	
TEST/NORMAL Switch	6B-25
Procedure CRT7 — Replacing Display Terminal	
MASTER CLEAR Switch	6B-26
Procedure CRT8 — Replacing Boards In Logic	
Module Card Cage	6B-27

SectionPage

Procedure CRT9 — Replacing Logic Module Card Cage	6B-29
Procedure CRT10 — Replacing Display Terminal Switches, Indicators, and Panels	6B-31
Procedure CRT11 — Replacing Video Printed-Circuit Board	6B-32
Procedure CRT12 — Replacing Display Terminal Video Module	6B-34
Procedure CRT13 — Replacing Display Terminal Cathode-Ray Tube	6B-38
Procedure CRT14 — Horizontal and Vertical Alignment	6B-40
Procedure CRT15 — Replacing Yoke on Display Terminal CRT	6B-43
Procedure CRT16 — Replacing Display Terminal Vertical Choke	6B-48
Procedure CRT17 — Replacing Display Terminal Bulk Power Supply Board	6B-49
Procedure CRT18 — Replacing Keyboard	6B-51
Procedure CRT19 — Replacing Display Terminal AC Entry Transformer	6B-52
Procedure CRT20 — Measuring Voltages at Video Printed-Circuit Board	6B-54
Procedure CRT21 — Removing Display Terminal Cabinet Hood	6B-58
Procedure CRT22 — Measuring Low Voltages	6B-59
Procedure CRT23 — Checking and Replacing INTENSITY Control on Display Panel	6B-63
Procedure CRT24 — Checking and Replacing Baud Rate Switches	6B-64
Procedure CRT25 — Checking Keyboard	6B-68
Procedure CRT26 — Adjusting Monitor	6B-70
Procedure CRT27 — Checking and Replacing CHARACTER/LINE/BLOCK Switch	6B-72
Procedure CRT28 — Checking and Replacing Two- Position Switches	6B-73
Procedure CRT29 — Checking and Replacing Audible Alarm	6B-74
Procedure CRT30 — Adjusting Refresh Stability	6B-75
Procedure CRT31 — Checking/Setting Auto Answerback ID Code	6B-84
Procedure CRT32 — Checking/Setting Current Loop Line-Adapter Switches	6B-86

Section

Page

Nonimpact Printer Corrective Maintenance

- Procedures — General 6C-3
- Procedure NIP1 — Paper Loading and Power On 6C-3
- Procedure NIP2 — 1-kHz Oscillator Adjustment 6C-5
- Procedure NIP3 — Retriggerable One-shot (ROS) Adjustment 6C-5
- Procedure NIP4 — Brake LED Block and Brake One-Shot Adjustment 6C-8
- Procedure NIP5 — Head Compensating Circuit Adjustment 6C-10
- Procedure NIP6 — Carriage Return LED Block Adjustment 6C-10
- Procedure NIP7 — Printhead Actuation Adjustment 6C-14
- Procedure NIP8 — Print Quality Adjustments 6C-17
- Procedure NIP9 — Out-of-Paper Switch Adjustment 6C-17
- Procedure NIP10 — Serial Input Clock Adjustment 6C-18
- Procedure NIP11 — Replacing Print Mechanism 6C-20
- Procedure NIP12 — Replacing Power Supply 6C-21
- Procedure NIP13 — Replacing/Adjusting Miscellaneous Parts 6C-22

Impact Printer Corrective Maintenance Procedures —

- General 6D-5
- Procedure IMP1 — Turning On Printer Power 6D-6
- Procedure IMP2 — Turning Off Printer Power 6D-8
- Procedure IMP3 — Installing/Aligning Paper Forms in Matrix Printer 6D-8
- Procedure IMP4 — Installing Ribbon in Printer 6D-11
- Procedure IMP5 — Installing Format Tape Impact Printer 6D-13
- Procedure IMP6 — Opening/Removing Impact Printer Cabinet 6D-15
- Procedure IMP7 — Removing/Replacing Logic Chassis Circuit Boards 6D-16
- Procedure IMP8 — Checking/Setting Internal Switches and Jumpers 6D-17
- Procedure IMP9 — Removing/Replacing Driver Circuit Board 6D-19
- Procedure IMP10 — Removing/Replacing Line Start Circuit Board 6D-19
- Procedure IMP11 — Removing/Replacing Character Start Circuit Board 6D-20
- Procedure IMP12 — Check/Replace Fuses 6D-21
- Procedure IMP13 — Removing/Replacing Internal Cables 6D-25

Section

Page

Procedure IMP14 — Checking Internal Cables 6D-26
 Procedure IMP15 — Mechanical Checks/Adjustments . . 6D-33
 Procedure IMP16 — Electrical Checks/Adjustments . . . 6D-33
 Procedure IMP17 — Parts Replacement 6D-34
 Tape Cassette Unit Corrective Maintenance Procedures —
 General 6E-3
 Procedure TCU1 — Turning On Tape Cassette Unit
 Power 6E-3
 Procedure TCU2 — Turning Off Tape Cassette Unit
 Power 6E-4
 Procedure TCU3 — Tape Cassette Loading/Unloading . . 6E-5
 Procedure TCU4 — Opening/Removing Tape Cassette
 Unit Cabinet 6E-6
 Procedure TCU5 — Removing/Replacing Logic Chassis
 Circuit Boards 6E-7
 Procedure TCU6 — Checking/Adjusting Power Supply
 Output 6E-8
 Procedure TCU7 — Removing/Replacing Power Supply
 Module 6E-10
 Procedure TCU8 — Removing/Replacing AC Entry Panel . 6E-11
 Procedure TCU9 — Removing/Replacing Fan Assembly . . 6E-11
 Procedure TCU10 — Removing/Replacing LED Board . . . 6E-13
 Procedure TCU11 — Checking/Replacing Front Panel
 Switches 6E-14
 Procedure TCU12 — Removing/Replacing Tape Drive(s) . 6E-15
 Procedure TCU13 — Checking/Repairing/Replacing
 Internal Cables 6E-16
 Procedure TCU14 — Cleaning Tape Drive Mechanism . . 6E-21

INDEX 6-23

APPENDIXES

E — 70-LPM IMPACT PRINTER INSTALLATION-CHECKOUT
 AND MAINTENANCE E-1
 F — 70-LPM IMPACT PRINTER SUPPLIES AND FORMAT TAPE
 PUNCHING F-1

FIGURES

<u>Section</u>	<u>Figure</u>	<u>Page</u>
3	—	INSTALLATION AND CHECKOUT
3-1	Crating and Uncrating the Keyboard Display Terminal	3-2
3-2	Crating and Uncrating the Nonimpact Printer	3-3
3-3	Crating and Uncrating the Impact Printer	3-4
3-4	Crating and Uncrating the Impact Printer Pedestal	3-5
3-5	Crating and Uncrating the Tape Cassette Unit	3-6
3-6	Packaging for Circuit Card Modules	3-7
3-7	Attaching Keyboard to Display Cabinet	3-11
3-8	Cabinet Hood Removal and 50-Hz Voltage	3-12
3-9	Internal Switches	3-13
3-10	TEST/NORMAL and MASTER CLEAR Switches	3-14
3-11	Subsystem Interconnecting Cables	3-16
3-11.1	Nonimpact Printer Controls	3-26
3-12	Impact Printer Access Space	3-26.1
6	—	MAINTENANCE
6-1	Example of a Diagnostic Decision Logic Table	6-17
6-2	Arrangement of Diagnostic and Corrective Maintenance Information	6-21
CRT1	High-Voltage Pin Numbers	6B-20
CRT2	High-Voltage Transformer Installation	6B-21
CRT3	+15-Volt Regulator Assembly	6B-23
CRT4	BP5 Connector Pins	6B-24
CRT5	AC Entry Panel Removal	6B-25
CRT6	TEST/NORMAL Switch Removal	6B-26
CRT7	MASTER CLEAR Switch	6B-27
CRT8	Logic Card Cage Board Locations	6B-28
CRT9	Logic Module Card Cage Removal	6B-30
CRT10	LED and Switch Panel Removal	6B-31
CRT11	Video Module Printed-Circuit Board Connections	6B-32
CRT12	Video Printed-Circuit Board Placement	6B-33
CRT13	Video Module Connector Removal	6B-34
CRT14	Video Module Mounting Screws Removal	6B-35
CRT15	Video Module Removal	6B-36
CRT16	Video Module Installation	6B-37
CRT17	CRT Socket Removal	6B-38

<u>Section</u>	<u>Figure</u>	<u>Page</u>
	CRT18 CRT Yoke Assembly	6B-39
	CRT19 Shielding Sleeve Positioning	6B-42
	CRT20 Focus, Contrast, and Vertical Linearity	6B-43
	CRT21 Removing Flag Terminals	6B-44
	CRT22 CRT Tube Socket Removal	6B-45
	CRT23 Yoke Assembly	6B-45
	CRT24 Positioning Shielding Sleeve	6B-46
	CRT25 Vertical Choke	6B-49
	CRT26 Bulk Power Supply Board	6B-50
	CRT27 Keyboard Assembly	6B-52
	CRT28 AC Entry Transformer	6B-53
	CRT29 Test Point for +465-V dc	6B-54
	CRT30 Test Point for -190-V dc	6B-55
	CRT31 Test Point for +45-V dc	6B-56
	CRT32 Test Pins for +5 and +15-V dc	6B-57
	CRT33 +5-V dc Regulator Board Test Points	6B-60
	CRT34 Memory and Processor Voltage Test Points	6B-62
	CRT35 Intensity Control	6B-64
	CRT36 High Baud Rate Set to 9600 — Low Baud Rate Set to 110	6B-65
	CRT37 Setting Low-Baud-Rate Switches	6B-66
	CRT38 Setting High-Baud-Rate Switches	6B-67
	CRT39 Bulk Power Supply Indicator Lights	6B-68
	CRT40 64 CHAR/96 CHAR Switch	6B-69
	CRT41 Special Control Code Keys	6B-69
	CRT42 Monitor Printed-Circuit Board Adjustments (Video Size Adjustments)	6B-71
	CRT43 Monitor Printed-Circuit Board Adjustments (Focus Adjustments)	6B-73
	CRT44 Adjusting Focus Ring Magnet Assembly	6B-74
	CRT45 Display Character Resolution	6B-74
	CRT46 Applying Plastic Overlay to CRT Screen	6B-75
	CRT47 Identifying Raster Distortion	6B-76
	CRT48 Installing Correction Magnet on Dowel	6B-76
	CRT49 CRT RASTER Overlay	6B-77
	CRT50 Positioning Correction Magnet to Yoke	6B-79
	CRT51 Typical Positioning of Correction Magnets on Yoke	6B-80
	CRT52 Checking Horizontally Mounted Sonalert Alarm	6B-84
	CRT53 Location of Vertically Mounted Sonalert Alarm	6B-85
	CRT54 Checking Sonalert Alarm	6B-86
	CRT55 Logic Module Decal (Switches and Adjustments)	6B-88

<u>Section</u>	<u>Figure</u>	<u>Page</u>
CRT56	Checksum Display	6B-90
CRT57	Raster Display	6B-90
CRT58	Terminal Configuration Display Bit Assignments	6B-91
CRT59	Back Panel Cabling of Logic Module	6B-92
CRT60	Logic Module Board Locations	6B-93
CRT61	AC Power Cabling	6B-94
CRT62	Installed Options	6B-95
CRT63	Answerback Pluggable-Diode Matrix Coding	6B-97
CRT64	Current Loop Line-Adapter Switches	6B-99
CRT65	Current Loop Line-Adapter Switch Settings	6B-100
NIP1	Paper Loading, Nonimpact Printer	6C-4
NIP2	Printer, Front View	6C-6
NIP3	Printer, Right Side View	6C-7
NIP4	Printer, Right Front View	6C-8
NIP5	Printhead Home Position	6C-11
NIP6	Guide Bar Arm Travel	6C-16
NIP7	Damper Pad Adjustment	6C-16
NIP8	Printer, Rear View	6C-18
NIP9	Serial Clock Timing	6C-19
NIP10	Location of Major Replaceable Modules	6C-21
IMP1	Forms Installing/Aligning in Impact Printer	6D-10
IMP2	Ribbon Path in Impact Printer	6D-12
IMP3	Ribbon Positioning on Spools	6D-12
IMP4	Format Tape Path in Impact Printer	6D-14
IMP5	Format Tape Characteristics	6D-14
IMP6	Logic Chassis Board Locations	6D-17
IMP7	Internal Switches and Jumpers (RS-232-C Board)	6D-18
IMP8	Solenoid Driver Board with Fuse Identification	6D-22
IMP9	Power Supply Board with Fuse Identification	6D-23
IMP10	Impact Printer Major Assemblies	6D-24
IMP11	Impact Printer Internal Connectors	6D-27
IMP12	60-Hz AC Distribution	6D-28
IMP13	Universal AC Distribution	6D-29
IMP14	DC Distribution and Ribbon Logic	6D-30
IMP15	Configuration Drawing	6D-31
IMP16	Chassis Map	6D-32

<u>Section</u>	<u>Figure</u>	<u>Page</u>
TCU1	Back and Front Panels	6E-4
TCU2	Cassette Features	6E-5
TCU3	Logic Chassis Board Locations	6E-7
TCU4	Power Supply (Test Points, Adjustments and Connections)	6E-9
TCU5	Cable Routing Diagram	6E-17
TCU6	Tape Cassette Unit Composition	6E-18
TCU7	Bottom View of Chassis (Removed From Cabinet Base)	6E-20
TCU8	Locations of Magnetic Tape Head, Capstans, and Rollers	6E-21

TABLES

<u>Section</u>	<u>Table</u>	<u>Page</u>
6	MAINTENANCE	
6-1	Keyboard Display PMTs	6-3
6-2	Nonimpact Printer PMTs	6-4
6-3	Impact Printer PMTs	6-7
6-4	Tape Cassette Unit PMTs	6-11
TS1	DDLTL for Terminal Subsystem	6A-1
CRT1	DDLTL for Display Terminal	6B-1
CRT2	DDLTL for Expanded Memory Function in Display Terminal	6B-9
CRT3	DDLTL for Highlight Function in Display Terminal	6B-10
CRT4	DDLTL for Edit Function in Display Terminal	6B-11
CRT5	DDLTL for Answerback Function in Display Terminal	6B-12
CRT6	DDLTL for Multidrop Function in Display Terminal	6B-13
CRT7	DDLTL for Current Loop Function in Display Terminal	6B-14
CRT8	DDLTL for Printer Interface Control Function in Display Terminal	6B-15
CRT9	DDLTL for TCU Interface Control Function in Display Terminal	6B-16
CRT10	DDLTL for +5-V Regulator Slave Function in Display Terminal	6B-17
CRT11	DDLTL for Paging Function in Display Terminal	6B-18
NIP1	DDLTL for Nonimpact Printer	6C-1
NIP2	Print Quality	6C-17
IMP1	DDLTL for Impact Printer	6D-1
TCU1	DDLTL for Tape Cassette Unit	6E-1

CRATING NOTES:

- 1) USE CRATING KIT 59125600.
- 2) DISASSEMBLE PEDESTAL AND ENCLOSE EACH OF FOLLOWING IN PLASTIC BAGS (59125605):
 - LEFT UPRIGHT WITH LEFT PANEL ATTACHED.
 - RIGHT UPRIGHT WITH RIGHT PANEL ATTACHED.
 - BOTTOM FRAME CROSS-MEMBER.
- 3) ASSEMBLE EXTERIOR BOX (59125601), USING CARTON-SEALING TAPE (59136111).
- 4) PLACE SEPARATOR PLAIN PAD (59125603) IN BOTTOM OF BOX.
- 5) PLACE LEFT AND RIGHT PEDESTAL UPRIGHTS INTO BOX AS INDICATED WITH CREASED SHEET SEPARATOR (59125602).
- 6) INSERT ANOTHER SEPARATOR PLAIN PAD (59125603).
- 7) PLACE PEDESTAL BACK PANEL AND BOTTOM FRAME CROSS-MEMBER INTO BOX AND SECURE WITH TAPE.
- 8) INSERT ANOTHER SEPARATOR PLAIN PAD (59125603).
- 9) ASSEMBLE INTERIOR BOX USING CARTON-SEALING TAPE (59136111).
- 10) PLACE ASSEMBLY HARDWARE IN INTERIOR BOX AND SEAL WITH CARTON-SEALING TAPE (59136111).
- 11) PLACE INTERIOR BOX AND ASSEMBLY INSTRUCTIONS IN EXTERIOR BOX.
- 12) SEAL FLAPS OF EXTERIOR BOX WITH CARTON-SEALING TAPE.

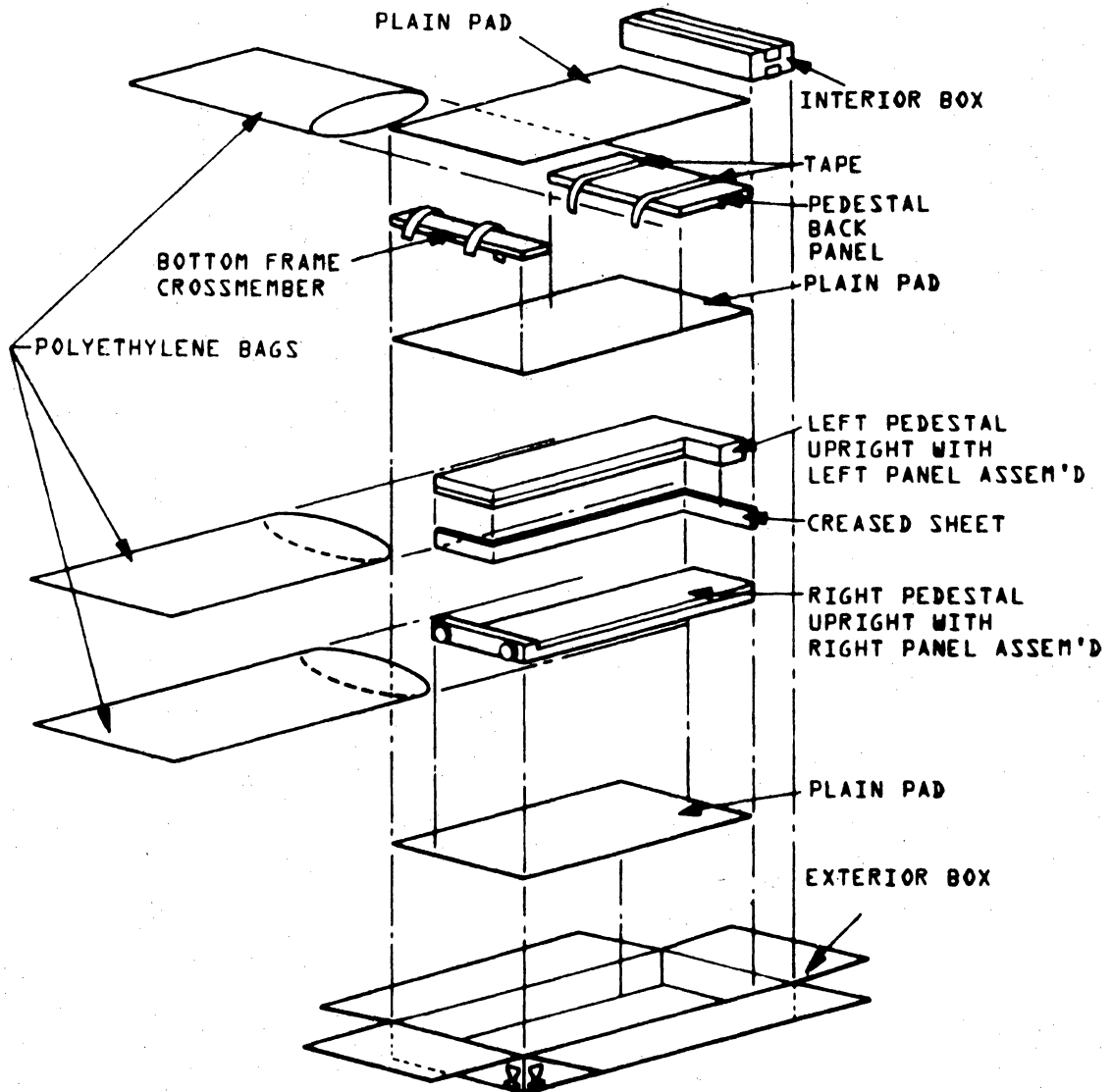

Figure 3-4. Crating and Uncrating the Impact Printer Pedestal

CRATING NOTES:

- 1) USE CRATING KIT 41037000
- 2) SET UP BOX (41037002)
- 3) SECURE CASSETTE COVERS WITH 3/4-INCH (1.9 CM) FILAMENT TAPE
- 4) PLACE CASSETTE WITH END CAPS (41037001) IN BOX
- 5) PLACE FOUR TOP INTERLOCKING BLOCKS IN POSITION
- 6) PLACE POWER CORD TOWARD REAR OF CASSETTE. PLACE OPTIONS, CABLES AND MANUALS ON SIDES OF CASSETTE
- 7) CLOSE BOX AND SEAL WITH 3-INCH (7.6 CM) REINFORCED BOX SEALING TAPE

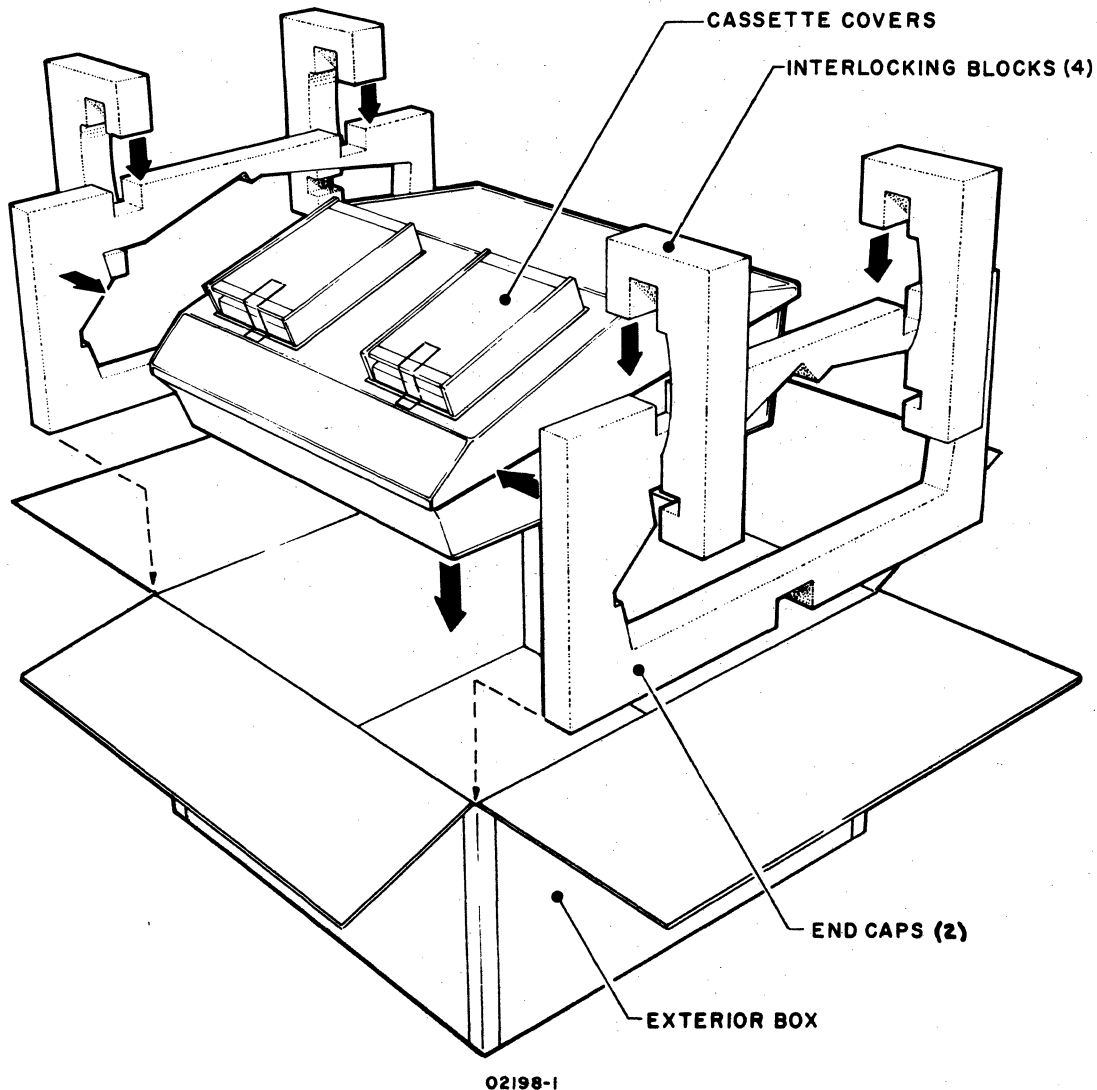

Figure 3-5. Crating and Uncrating the Tape Cassette Unit

CRATING NOTES:

- 1) USE CRATING KIT 59113100.
- 2) RESTRAIN PRINthead FROM SIDEWAYS MOVEMENT (E.G., TIE TO SIDE BY LOOPING SMALL RUBBERBAND AROUND HEAD AND ANY SECURE PROTRUSION ON PRINTER CHASSIS SIDE PLATE).
- 3) COIL POWER CORD NEATLY AND WRAP AROUND WITH TWO OR THREE LOOPS OF TAPE.
- 4) PLACE END CAPS ON PRINTER AND LOWER PRINTER WITH END CAPS DOWN INTO PACKING BOX.
- 5) CLOSE AND SEAL BOX FLAPS WITH REINFORCED BOX SEALING TAPE.

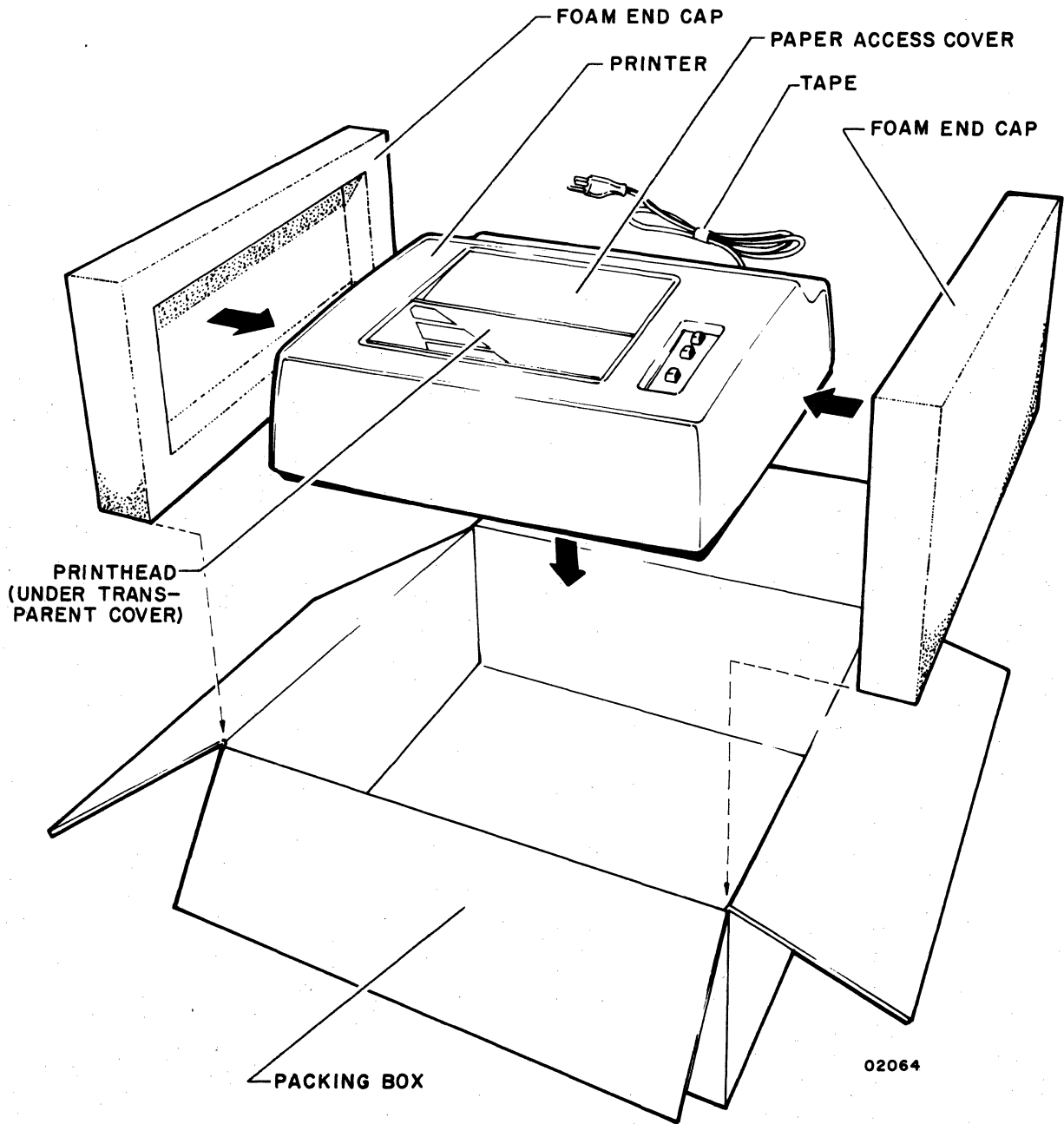

Figure 3-2. Crating and Uncrating the Nonimpact Printer

CRATING NOTES:

- 1) USE CRATING KIT 59125400.
- 2) SECURE PRINTER CHASSIS TO CABINET BASE BY INSTALLING TWO M6x8 SHIPPING SCREWS. INSTALL SCREWS FROM UNDER PRINTER IN HOLES PROVIDED.
- 3) ASSEMBLE EXTERIOR CONTAINER BOTTOM (59125413) USING FILAMENT TAPE TO SECURE FLAPS.
- 4) PLACE TWO LOWER END CUSHIONS (59125411) INTO BOTTOM ENDS OF CONTAINER.
- 5) POSITION PLASTIC DUST COVER (59125407), CLOSED END DOWN, INTO CONTAINER AND SPREAD OPEN END OVER CONTAINER RIM.
- 6) POSITION PRINTER IN DUST COVER SO IT MOUNTS SECURELY IN LOWER END CUSHIONS.
- 7) COIL CABLE BEHIND PRINTER.
- 8) PLACE FOUR DESICCANT BAGS (59124408) INTO PLASTIC DUST COVER WITH PRINTER AND HEAT SEAL TOP OF DUST COVER.
- 9) PLACE UPPER END CUSHIONS (59125412) INTO POSITION ON ENDS OF PRINTER CABINET.
- 10) CLOSE BOX FLAPS AND SECURE WITH FILAMENT TAPE (59136109).
- 11) PLACE PRINTER BOX ON SHIPPING SKID (59125408).
- 12) PLACE PACKAGED PEDESTAL (OPTIONAL) BOX ON TOP OF PRINTER BOX AND STRAP TO SKID USING STEEL STRAPPING (59196107), CLAMPS (59136108) AND CORNER PROTECTORS (59136123).

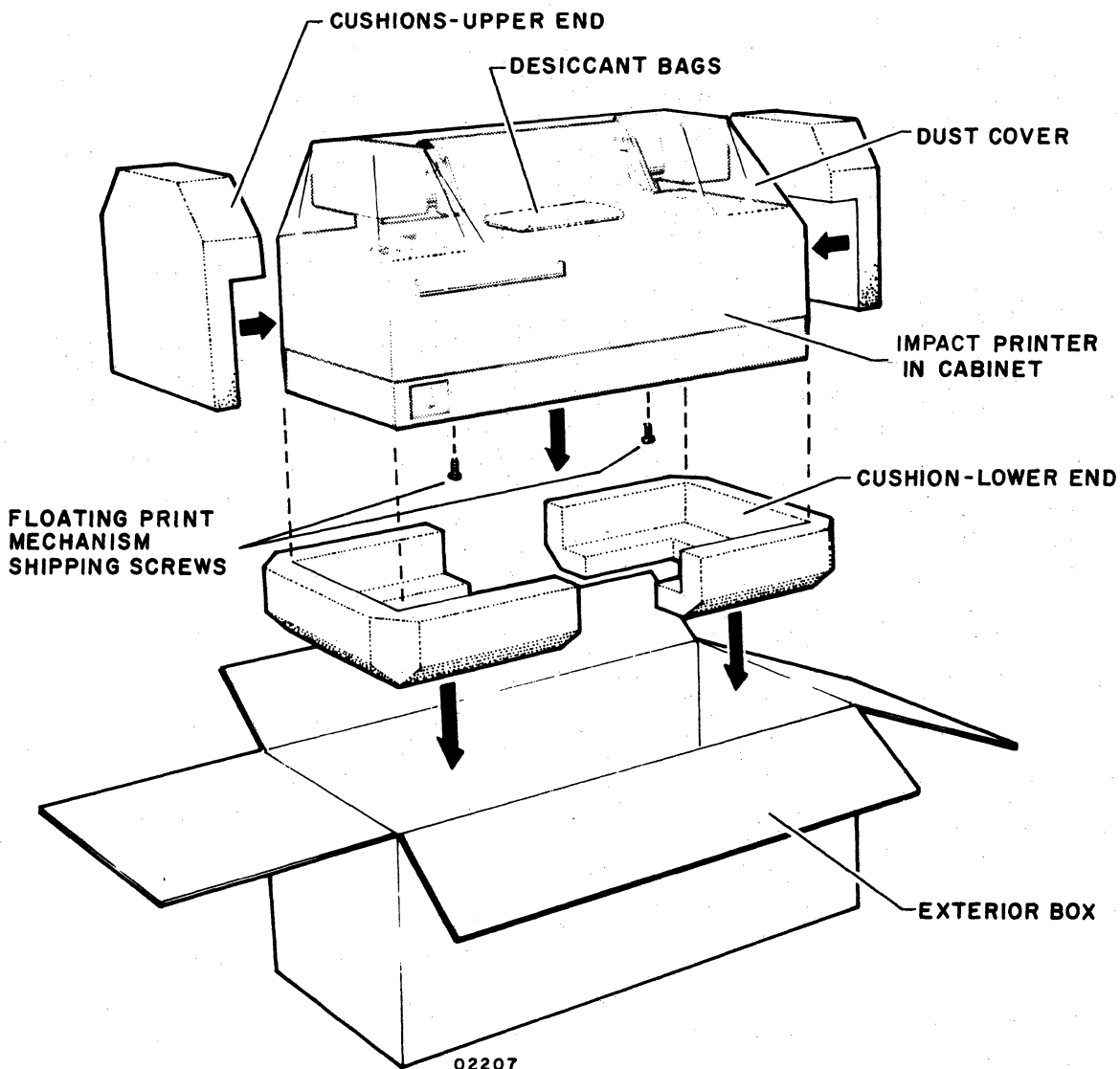

Figure 3-3. Crating and Uncrating the Impact Printer

This section provides information regarding crating, uncrating, installation, and checkout of the various equipments which may comprise a terminal subsystem. Included are instructions on how to handle the various supplemental circuit cards which may require installation in the display cabinet.

CRATING

To properly protect the keyboard display, printer, tape cassette unit, and any portion thereof for shipment, always use only company approved procedures and materials. To obtain proper materials, contact the nearest Control Data representative or:

Control Data Corporation
Corporate Traffic
8100 34th Avenue South
Minneapolis, Minnesota 55440

Following figures and text describe crating for each of the cabinet-level equipments possible in a terminal subsystem. In addition, information is supplied for packing lower-level hardware which may reside within the equipments.

To crate the keyboard display terminal, refer to figure 3-1. If desired, a template is available for cutting out the polystyrene packing material. Order D-size drawing no. 41035301 from CDC Corporate Traffic.

To crate the nonimpact printer, refer to figure 3-2.

To crate the impact printer, refer to figures 3-3 and 3-4.

To crate the tape cassette unit (single or dual drive) refer to figure 3-5.

To package any circuit card module for shipment separately from an equipment cabinet, refer to figure 3-6.

To ship any other subassembly (e.g., television monitor, power supply, print mechanism, tape drive mechanism, etc.), try to pack it in the carton which held its replacement. Always unpack items carefully (see Uncrating, later in this section), so that replaced items shipped for repair can be packed properly. It is good practice to have packing material on hand at each site for any on-site-replaceable item. For subassemblies, it may be possible to use the spare parts containers brought to the site by the customer engineer.

CRATING NOTES:

- 1) USE CRATING KIT 41035800 WITH 41035801 END FRAMES (2) AND 41035802 EXTERIOR CONTAINER.
- 2) INTERLOCK FOAM BASE LEGS WITH END FRAMES.
- 3) PLACE END FRAMES WITH BASE LEGS ON DISPLAY.
- 4) PLACE DISPLAY WITH END FRAMES INTO CONTAINER.
- 5) INTERLOCK "T" BLOCKS WITH END FRAMES.
- 6) LIFT TOP FLAPS ON END FRAMES AND INSTALL KEYBOARD WITH KEYS FACING DOWN.
- 7) SECURE CABLES IN END FRAME SLITS AS SHOWN.
- 8) CLOSE AND SEAL CONTAINER WITH 3-INCH (7.6 CM) WHITE REINFORCED BOX SEALING TAPE.

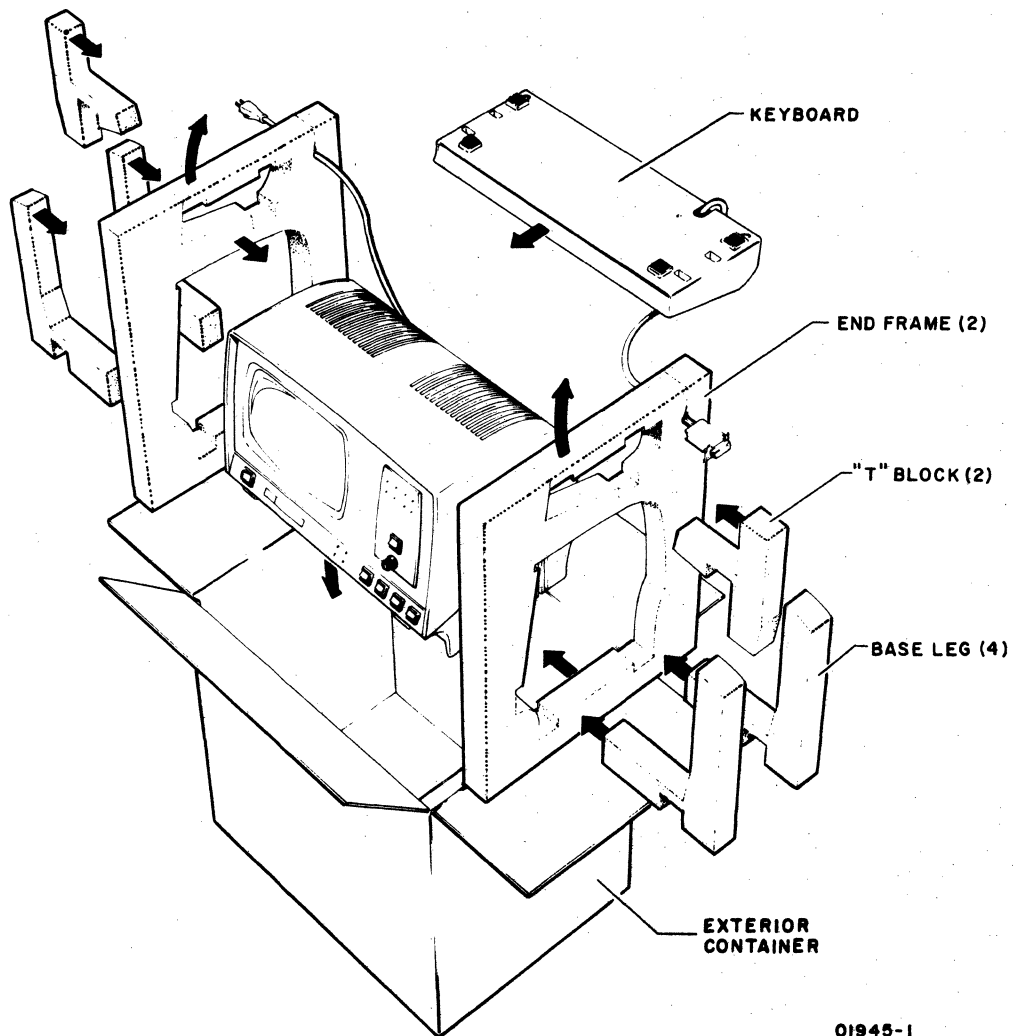

01945-1

Figure 3-1. Crating and Uncrating the Keyboard Display Terminal

CRATING NOTES:

- 1) PRESENCE OF STATIC ELECTRICITY MAY DESTROY SENSITIVE MOS CIRCUITS, E.G., ROM OR STATIC SHIFT REGISTER CIRCUITS.
ANY CIRCUIT CARD CONTAINING MOS CIRCUITS (STATIC-ELECTRICITY SENSITIVE) REQUIRES SPECIAL HANDLING. USE "MOS CIRCUIT HANDLING PRECAUTIONS" IN APPENDIX C AND WRAP CARD IN STATIC-PROTECTIVE MATERIAL, E.G., ALUMINUM FOIL. ALSO REFER, IF DESIRED, TO CDC SPECIFICATION 16033100 WHICH DESCRIBES SPECIAL HANDLING FOR MOS TYPE CIRCUITS.
- 2) ONLY ONE CARD MAY BE PLACED IN A PADDED BAG.
SLIDE A CIRCUIT CARD IN A #2 SIZE PADDED SHIPPING BAG.
- 3) PACK EACH BAGGED CARD, OR SEVERAL BAGS (EACH WITH ONE CARD), IN A CORRUGATED SHIPPING CONTAINER. FILL ANY VOIDS WITH CUSHIONING PACKING MATERIAL.

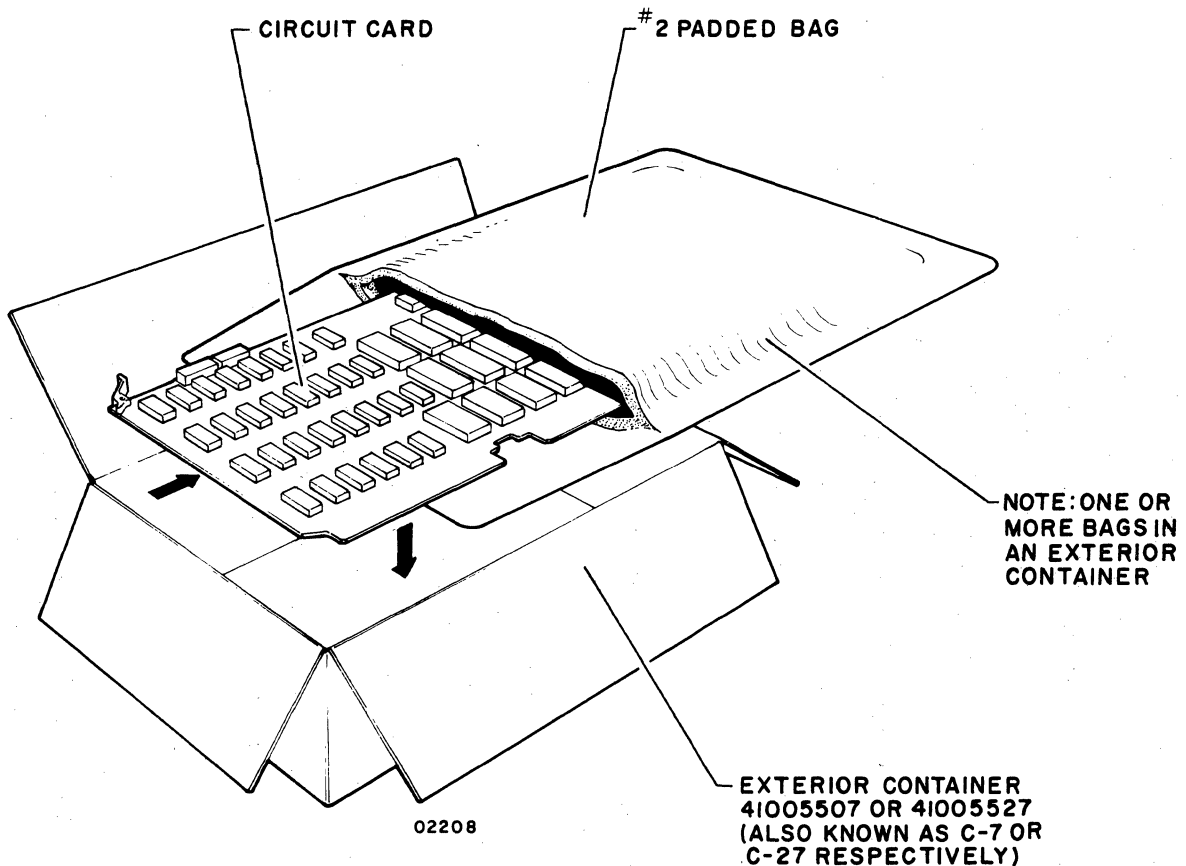

Figure 3-6. Packaging for Circuit Card Modules

NOTE

Shipping the video monitor PC board (6BND) improperly packaged results in damage to the horizontal width adjustment coil. A special shipping container that prevents this damage, part number 41037700, is now available from the parts warehouse. When a video monitor PC board is shipped, this container should be used.

UNCRATING

Following paragraphs describe uncrating for each of the cabinet-level equipments possible in a terminal subsystem. In addition, information is supplied for unpacking lower-level hardware which may reside within the equipments. Save packing material for returning a replaced item (see Crating, earlier in this section, for shipping container requirements).

KEYBOARD DISPLAY

To uncrate the keyboard display, refer to figure 3-1 and proceed as follows:

- 1) Open top of exterior container and lift cables secured in end frame slits of packaging material.
- 2) Lift top flaps of end frames and remove keyboard.
- 3) Remove two "T" blocks interlocked in the end frames.
- 4) Remove display, with end frames attached, from exterior container.
- 5) Remove end frames and any remaining packaging material from display.
- 6) Inspect display and keyboard for any shipping damage.

NONIMPACT PRINTER

To uncrate the nonimpact printer, refer to figure 3-2 and proceed as follows:

- 1) Open top of shipping carton and remove any packing material.
- 2) Lift printer, including end caps, from carton.
- 3) Remove end caps from printer and remove any poly covering.
- 4) Open paper-access cover and remove restraint from printhead. It may be necessary to remove cabinet top (by unscrewing two retainer-screws at rear of cabinet each 1/4-turn), to reach restraint. This depends on what type of restraint is present and how it is positioned.
- 5) Inspect printer for possible shipping damage.

IMPACT PRINTER

To uncrate the impact printer, refer to figure 3-3 and proceed as follows:

- 1) Cut and remove steel strapping and remove pedestal package (optional) from top.
- 2) Open printer box and remove upper end cushions.

- 3) Carefully cut open plastic dust cover and remove any materials from top of printer.

CAUTION

The printer weighs approximately 78 lb (35 kg).

- 4) Reach into dust cover and lift out the printer.
- 5) Carefully place printer on solid surface.
- 6) Remove two screws securing cabinet base plate to floating printhead.
- 7) Inspect printer for possible shipping damage.
- 8) If using optional pedestal, refer to figure 3-4, and open pedestal box, remove assembly instruction sheet, remove packing materials from pedestal parts, and assemble pedestal per instruction sheet.
- 9) Attach printer to pedestal (optional), per instruction sheet.

TAPE CASSETTE UNIT

To uncrate the tape cassette unit (either single or dual drive), refer to figure 3-5 and proceed as follows:

- 1) Open top of carton and remove any packing material.
- 2) Lift tape cassette unit, including end caps, from carton.
- 3) Remove end caps from unit and remove any poly covering.
- 4) Inspect tape cassette unit for possible shipping damage.

CIRCUIT CARD MODULES

To unpack any circuit card module(s), refer to figure 3-6, and proceed as follows:

- 1) Open exterior corrugated box.

CAUTION

Follow MOS Circuit Handling Precautions, described in appendix C, to handle circuit card(s).

- 2) Open envelope(s) and remove card(s).
- 3) Verify that card(s) are clean of all packing material and inspect for possible shipping damage.

MISCELLANEOUS SUBASSEMBLIES

When unpacking any subassembly replacement part for one of the terminal subsystem equipments, always proceed carefully, and remember the following:

- 1) Preserve condition of shipping container and packing material to pack replaced subassembly for shipment.
- 2) Observe exact manner of packing of received item and pack returnable item in same proper manner.

INSTALLATION AND CHECKOUT

The following paragraphs describe proper installation and checkout for the various cabinets/equipments/modules which may comprise a terminal subsystem. Instructions are given for the:

- Keyboard display
- Supplemental function modules (cards) for the keyboard display terminal
- Nonimpact character printer
- Impact character printer
- Tape cassette unit (single and dual drive)
- Complete terminal subsystem

CAUTION

Since the circuits throughout this subsystem use MOS type integrated circuit chips, which may be destroyed by an excessive static electric charge, always observe MOS circuits handling procedures (see appendix C) when connecting/disconnecting any cabinets, modules, components, or parts in the subsystem.

KEYBOARD DISPLAY INSTALLATION

To install a keyboard display, perform the following:

- 1) Remove unit from shipping/storage container per uncrating procedures.

CAUTION

At no time allow convection to be obstructed around, beside, or above the unit. Obstructing cooling slots in access cover, base, and hood will cause overheating.

- 2) Place unit on clean, sturdy work surface, e.g., desk top. Leave at least a 4-inch (10.2-cm) clearance on either side and at back of unit for air intake and cooling, and at least 2 feet (61 cm) of nonrestricted airspace above unit. During checkout leave at least 2 feet (61 cm) of work room at back of unit for connecting cables, setting internal switches, etc. Ambient temperature should be per specification in section 1. (Unit may be slid back against wall after other installation procedures are completed, but airspace requirements at sides and top of unit must be maintained.)
- 3) Refer to figure 3-7 and attach keyboard cable connector to display cabinet where shown. Secure connector with two retaining screws.

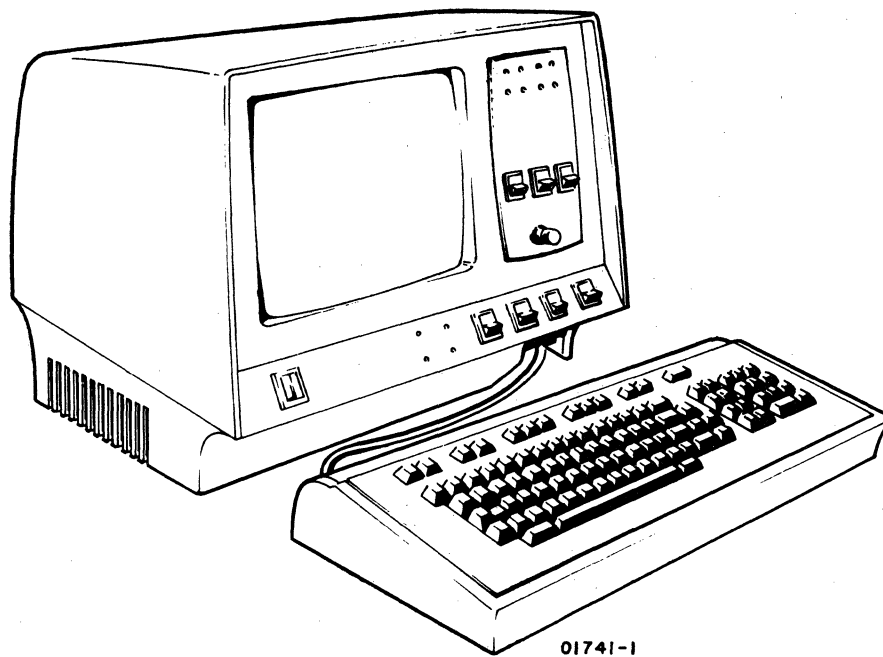

Figure 3-7. Attaching Keyboard to Display Cabinet

- 4) Remove cabinet hood by unscrewing two mounting screws in rear of cabinet (figure 3-8) and carefully sliding hood back and up.

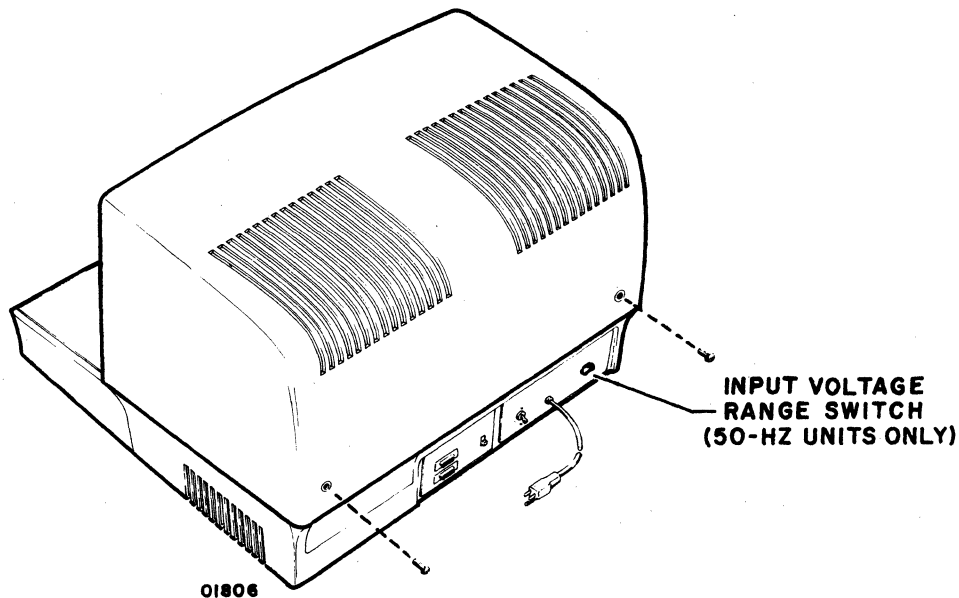

Figure 3-8. Cabinet Hood Removal and 50-Hz Voltage

- 5) Verify specific site requirements for functions/operations selected via rocker switches provided on logic module circuit cards (figure 3-9). If necessary, question site personnel.

NOTE

Due to the large variety of switch-selectable functions available with this unit, it is important to proceed thoroughly and carefully when setting/checking switches. Most installation/check out problems encountered involve improper switch settings or misunderstanding of switch operations. Methodically set/check each switch and log each switch setting on the Terminal Subsystem Installation Options Sheet. (Two of these are provided in appendix C of this manual.) When all switch settings are completed, verify that they are properly set for the specific site and application. Copy the switch settings onto a similar sheet in front of the user's operators guide for an on-site record of the functions/operations enabled and disabled.

- 6) Set/check all switches by making use of decals on inside of hood (see figure CRT55 in section 6 for decals) for individual switch identification. If high/low baud rate setting differs from that required on site, refer to procedure CRT24 in section 6 for instructions. If any other switches require changing for specific site application, use thin, blunt-pointed instrument to toggle them to proper position. (Do not use a lead pencil to set rocker switches. Graphite dust from the pencil can cause an equipment malfunction.)
- 7) Carefully inspect all cards for proper seating and all cables/wires for tight connections. Also, verify cabinet/chassis is clear of debris.
- 8) For 50-Hz units only — if primary input power to terminal from site power source measures between 195 and 245-V ac, slide INPUT VOLTAGE RANGE SWITCH (figure 3-8) to LOW LINE position. If input power measures between 216 and 268-V ac, slide INPUT VOLTAGE RANGE SWITCH to NORMAL position. Again, verify proper position of 50/60-Hz Refresh switch located on memory board in logic rack (figure CRT55, section 6).

This completes the basic installation of the keyboard display. Further tasks, associated with installation, e.g., system I/O cable connecting, are described as part of the checkout procedures which follow.

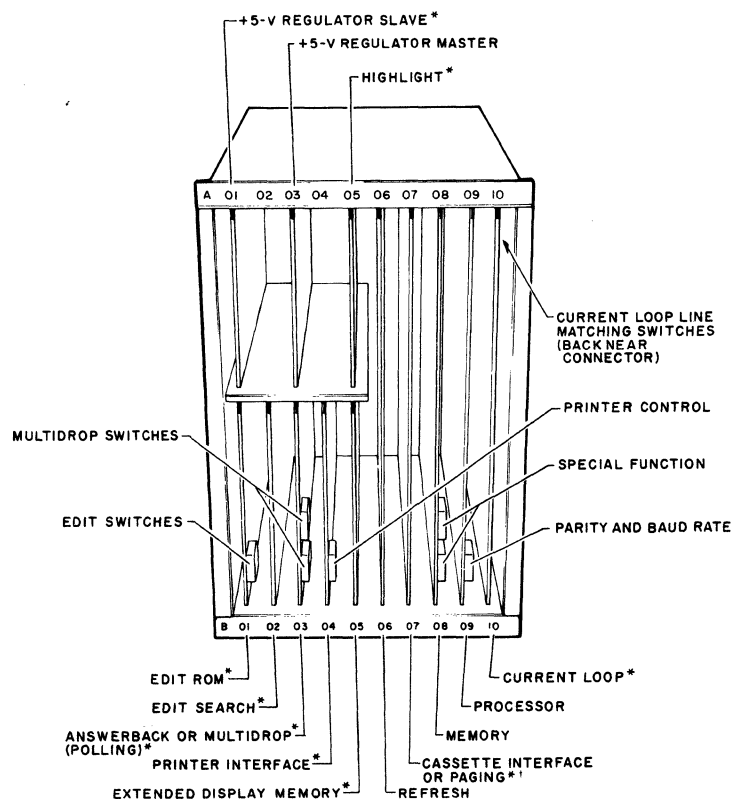

*DENOTES SUPPLEMENTAL FUNCTION IN ADDITION TO THOSE REQUIRED FOR A MINIMUM, BUT OPERATIONAL, KEYBOARD DISPLAY TERMINAL. (EXTENDED DISPLAY MEMORY IS ALWAYS PRESENT FOR 24 DISPLAY LINES.)

†WHEN TAPE CASSETTE IS INSTALLED THE BATCH MODE SWITCH MUST BE DISABLED.

02205-3

KEYBOARD DISPLAY CHECKOUT

To check operation of the keyboard display, perform the following:

- 1) Install cabinet hood.
- 2) Plug ac power cord into site ac power outlet.
- 3) Press POWER ON/OFF switch to ON. Wait 90 seconds.

NOTE

When POWER ON/OFF switch is turned off, wait 90 seconds before turning it on again or circuit breaker may trip.

- 4) Set TEST/NORMAL switch to TEST (up) and press MASTER CLEAR (see figure 3-10). This initiates diagnostic test series provided in logic module ROM circuits (see Subsystem Test Mode Diagnostic heading in section 6 for test description). Following display should appear on screen:

```
0F00 00 0E00 00 0D00 00 0C00 00 0B00 00 0A00 00 0900 00 0800 00 0700 00
0600 00 0500 00 0400 00 0300 00 0200 00 0100 00 0000 00
```

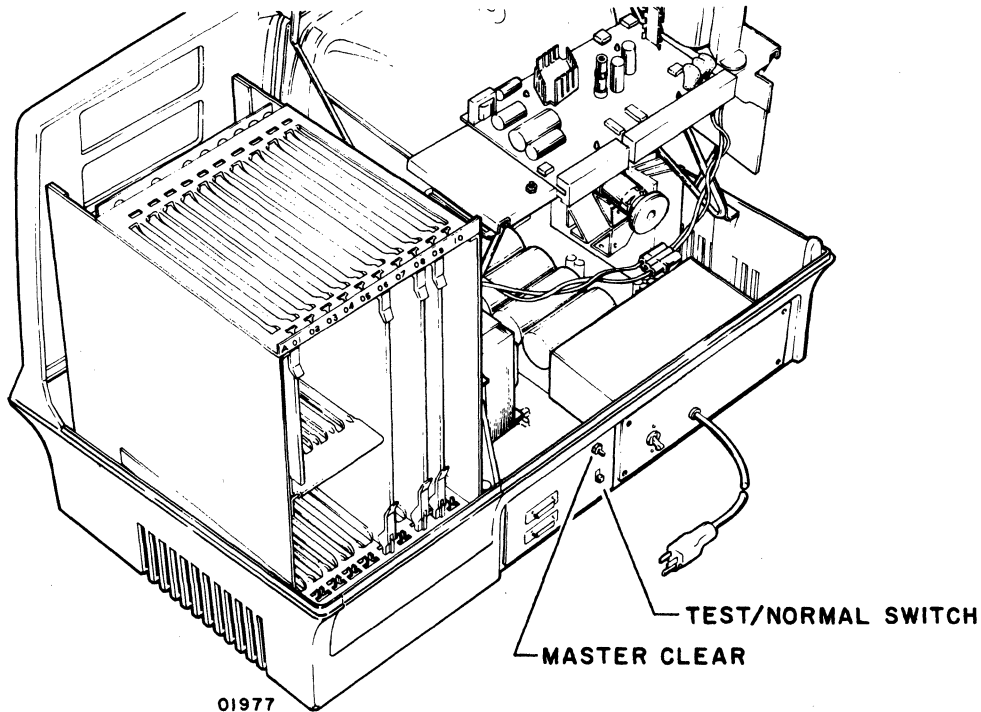

Figure 3-10. TEST/NORMAL and MASTER CLEAR Switches

In addition, the three CHAR/LINE/BLOCK TRANSMISSION MODE LEDs on the front panel should all appear extinguished to indicate Test Section 0. This is because the binary count of these three LEDs indicates the active test section (Test Sections 0 through 7, see table CRT1 in section 6) when the terminal is in TEST mode, e.g., CHAR and LINE extinguished but BLOCK illuminated indicates Test Section 1; for RAM Test Section 1 shown by sheet 2 of table CRT1.

- 5) If preceding display (checksum) does not appear on screen, go to table CRT1, DDLT for Display Terminal (section 6) to determine trouble.
- 6) With checksum appearing on screen, press space bar to proceed through various tests. If alarm sounds, an error is detected by test program. To proceed under error conditions, press Q key (either uppercase or lowercase) to disable alarm tone and go to table CRT1, DDLT for Display Terminal, for corrective action in section 6.

NOTE

Except for steps 9 and 10, pressing any displayable character/symbol key will advance to test.

- 7) Press space bar a second time and program begins writing characters on screen at present setting of baud rate switches. If HIGH RATE/300/LOW RATE switch is set to LOW RATE and internal low rate setting is 110 baud, it takes approximately 15 seconds for characters to appear on screen (after space bar was pressed second time). If unable to display data, proceed to table CRT1, DDLT for Display Terminal (section 6).
- 8) Pressing space bar a third time advances test program to keyboard check. Press any key on keyboard and observe that corresponding character appears on displays.
- 9) Press space bar again. Screen should go blank.
- 10) Press space bar again and test program advances to next test. Keep pressing space bar until eight characters appear in upper-left corner of display.
- 11) Move all following switches and observe first two characters on screen:
 - CHARACTER/LINE/BLOCK
 - FULL DUPLEX/HALF DUPLEX
 - ON LINE/LOCAL
 - FORMAT
- 12) If there is any reason to suspect that unit is not operating correctly, proceed to section 6 for thorough troubleshooting procedures. In so doing, always enter table CRT1, sheet 1, DDLT for Display Terminal first.

The preceding steps provide a quick check of the keyboard display to ensure it is working. They do not thoroughly check out every circuit or perform in-depth troubleshooting as do the DDLT's in section 6. However, if the terminal must be input into use immediately, the preceding should be performed as a minimum. When finished with the preceding steps, proceed as follows before placing terminal online.

- 13) Position TEST/NORMAL switch to NORMAL and press MASTER CLEAR.
- 14) Switch POWER ON/OFF switch to OFF, connect RS-232-C system I/O cable between display cabinet and site modem (see figure 3-11, Subsystem Interconnecting Cables, for cable part number/location). For current loop, connect site cable connector directly to data set connector at back of display cabinet. Tighten all connector screws.

This completes installation and checkout of the basic keyboard display terminal. If it is used alone as a terminal subsystem, it should be ready for use on the system (see Complete Terminal Subsystem at the end of this section for further information). If it uses peripheral equipment, or requires installation of any supplemental function(s), continue subsystem installation and checkout with information supplied in following paragraphs, as it applies to the particular site subsystem configuration.

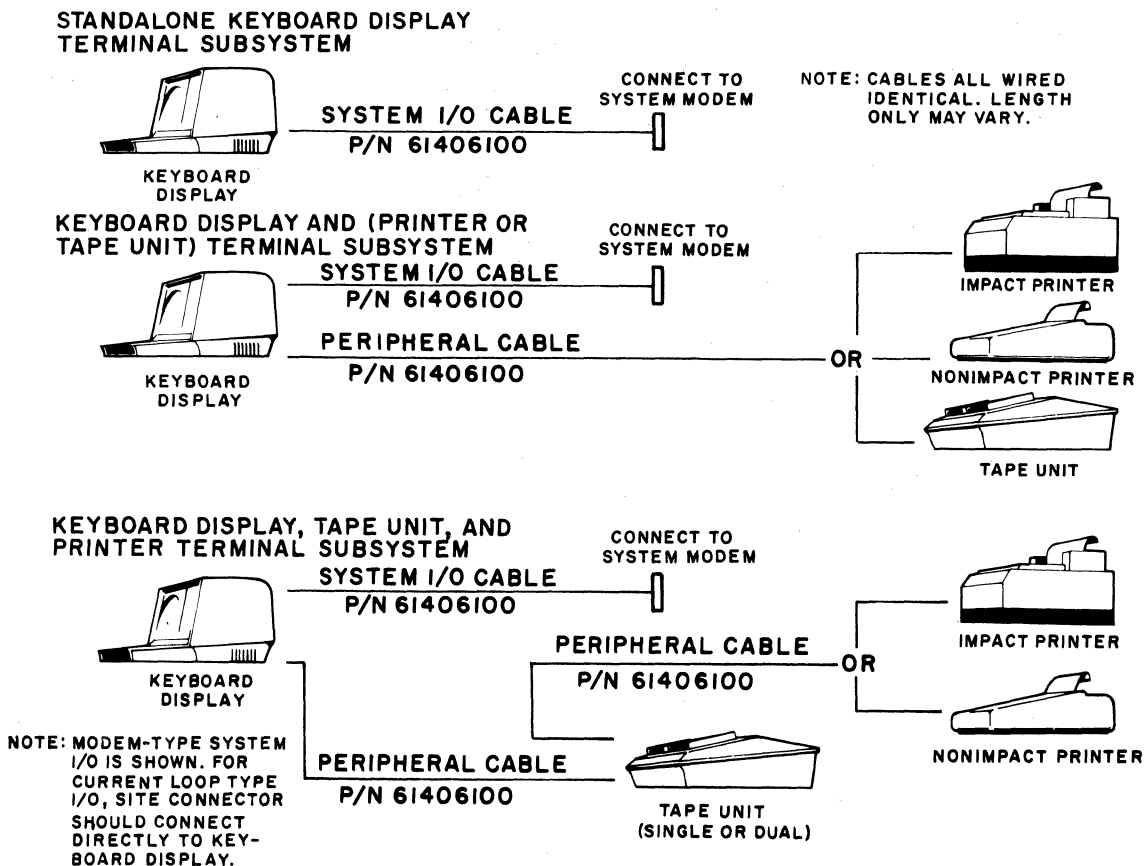

02210

Figure 3-11. Subsystem Interconnecting Cables

INSTALLING SUPPLEMENTAL FUNCTION MODULES

Additional, supplemental function logic cards may be installed in the internal logic rack of the keyboard display. These additional modules expand subsystem capability with a particular type of function. These modules are in the form of either half-size or full-size printed circuit cards. As shown in figure 3-9, supplemental modules for this subsystem may be:

- Extended display memory
- Highlight
- Edit (four modules: edit search, edit ROM, highlight, and extended memory)
- Answerback
- Multidrop (polling)
- Current loop system interface
- Printer interface control
- Tape cassette unit interface control
- +5-V regulator slave (required when addition of supplemental functions makes +5-V current draw (internal logic) approach 10 amperes (see Specifications in section 1 which gives the +5-V current requirements for each module which may be used).
- Paging (two modules: paging and extended memory)

To install any supplemental circuit module(s) in the display logic rack, proceed as follows:

- 1) Remove module(s) from package (see uncrating procedure).
- 2) Set any switches or jumpers on card to required positions (see figure CRT55, section 6) for the particular system application.
- 3) With POWER ON/OFF switch to OFF, carefully slide card into proper position in logic rack (procedure CRT8 in section 6).

CHECKING SUPPLEMENTAL FUNCTION MODULES

Following procedures describe how to check operation of any of the previously listed supplemental modules which may be added to the basic logic module in the display cabinet.

Extended Display Memory

With the card levered firmly in place, check extended memory operation as follows:

- 1) Do all steps of Keyboard Display Checkout (in a previous portion of this section) to verify that adding the card did not degrade performance. While doing this, observe display for 24 lines of characters. See that the terminal configuration displayed by Test Mode, Section 7 (reference figure CRT58) indicates that extended memory is present.
- 2) If any incident occurs to suspect incorrect operation, proceed to section 6 for thorough troubleshooting procedures. Begin troubleshooting at table CRT2, DDLT for Extended Memory Function in Display terminal.
- 3) When finished checking performance, before placing terminal online, put TEST/NORMAL switch to NORMAL and press MASTER CLEAR.

This completes the extended memory function checkout. Proceed to use the terminal per the particular site requirements. If any trouble should occur, use table TS1 in section 6 to begin detailed troubleshooting.

Highlight

With the card levered firmly in place, check highlight operation as follows:

- 1) Do all steps of Keyboard Display Checkout (in a previous portion of this section) to verify that adding the card did not degrade performance.
- 2) After placing TEST/NORMAL switch to NORMAL, pressing MASTER CLEAR, and placing ON LINE/LOCAL switch in LOCAL position - refer to the terminal subsystem operator's guide and via the keyboard, exercise the highlight functions (begin reduced intensity and override blink, end reduced intensity and/or blink, and begin blink if not within an existing reduced intensity field). Check that these highlight functions operate as described in the operator's guide.
- 3) If any incident occurs to suspect incorrect operation, proceed to section 6 for thorough troubleshooting procedures. Begin troubleshooting at table CRT3, DDLT for Highlight Function in Display Terminal.
- 4) When finished checking highlight performance, before placing terminal online, verify that TEST/NORMAL switch is at NORMAL and press MASTER CLEAR.

This completes the highlight function checkout. Proceed to use the terminal per the particular site requirements. If trouble occurs, use table TS1 in section 6 to begin detailed troubleshooting.

Edit

With the edit ROM, edit search, highlight, and expanded memory cards levered firmly in place, check edit operation as follows:

- 1) Do all steps of Keyboard Display Checkout (in a previous portion of this section) to verify that adding the edit cards did not degrade performance. See that terminal configuration displayed by Test Mode Section 7 (reference figure CRT47, section 6) indicates that edit is present.
- 2) After placing TEST/NORMAL switch to NORMAL, pressing MASTER CLEAR, and placing ON LINE/LOCAL switch in LOCAL position - refer to the terminal subsystem operator's guide and exercise all edit functions (character insert/delete, line insert/delete, tab/backtab, fix format, and X - Y positioning). Check that edit functions operate in both line and block modes as described in the operator's guide.
- 3) If any incident occurs to suspect incorrect operation, proceed to section 6 for thorough troubleshooting procedures. Begin troubleshooting at table CRT4, sheet 1, DDLT for Edit Function in Display Terminal.
- 4) When finished checking edit performance, before placing terminal online, verify that TEST/NORMAL switch is at NORMAL and press MASTER CLEAR.

This completes the edit function checkout. Proceed to use the terminal per the particular site requirements. If trouble occurs, use table TS1 in section 6 to begin detailed troubleshooting.

Answerback

To check answerback operation proceed as follows:

- 1) With card removed from rack (procedure CRT8 in section 6) visually check that pluggable diodes are where necessary to form the auto answerback ID code required by the communication system (procedure CRT31 in section 6). Relocate diodes if required.
- 2) Place answerback card in card cage (procedure CRT8).
- 3) Do all steps of Keyboard Display Checkout (in a previous portion of this section) to verify that adding the card did not degrade performance. See that terminal configuration displayed by Test Mode Section 7 (reference figure CRT58, section 6) indicates that answerback is present.

- 4) After placing TEST/NORMAL switch to NORMAL and pressing MASTER CLEAR, toggle the large maintenance test switch on the answerback card to ON (or MAINT, depending on card model) and press HERE IS key. Characters formed by the pluggable diode matrix on the answerback card should appear on the display screen. These characters are the system identification of the particular terminal subsystem installation and may include up to 21 characters as plugged in the card. If proper characters do not appear on the display screen, go to table CRT5, DDLT for Answerback Function in Display Terminal (section 6) to determine trouble.

This completes the answerback function checkout. Proceed to use the terminal per the particular site requirements. If trouble occurs, use table TS1 in section 6 to begin detailed troubleshooting.

Multidrop

With the card levered firmly in place, check multidrop operation as follows:

- 1) Observe that selectable switch settings match communication system requirements for correct multidrop operation (reference figure CRT55, section 6).
- 2) Do all steps of Keyboard Display Checkout (in a previous part of this section) to verify that adding the card did not degrade performance. See that the terminal configuration displayed by Test Mode Section 7 (reference figure CRT58, section 6) indicates that multidrop is present.
- 3) Verify that TEST/NORMAL switch is at NORMAL and press MASTER CLEAR.
- 4) Following site-particular communication system protocol, call in to the system and request the various multidrop operations possible, one at a time. Use subsystem operator's guide for terminal key/switch operations.
- 5) If any incident occurs to suspect incorrect operation, proceed to section 6 for thorough troubleshooting procedures. Begin troubleshooting at table CRT6, sheet 1, DDLT for Multidrop Function in Display Terminal.
- 6) When finished checking multidrop performance, take terminal offline and with TEST/NORMAL switch at NORMAL, press MASTER CLEAR.

This completes the multidrop function checkout. Proceed to use the terminal per the particular site requirements. If trouble occurs, use table TS1 in section 6 to begin detailed troubleshooting.

Current Loop System Interface

To check current loop interface operation, proceed as follows:

- 1) With card removed from rack (procedure CRT8 in section 6) visually check that line-adapter switches are set as required to match the particular type of current loop line (procedure CRT 32 in section 6). Set switches as required.
- 2) Place current loop card in card cage (procedure CRT8 in section 6).
- 3) Do all steps of Keyboard Display Checkout (in a previous part of this section) to verify that adding the card did not degrade performance.
- 4) Verify that TEST/NORMAL switch is at NORMAL and press MASTER CLEAR.
- 5) Following site-particular communication system protocol, send and receive messages to/from the system and observe terminal for correct results. Use subsystem operator's guide for terminal key/switch operations.
- 6) If any incident occurs to suspect incorrect operations, proceed to section 6 for thorough troubleshooting procedures. Begin troubleshooting at table CRT7, sheet 1, DDLT for Current Loop Interface in Display Terminal.
- 7) When finished checking current loop performance, before placing terminal online, verify that TEST/NORMAL switch is at NORMAL and press MASTER CLEAR.

This completes the current loop interface function checkout. Proceed to use the terminal per the particular site requirements. If trouble occurs, use table TS1 in section 6 to begin detailed troubleshooting.

Printer Interface Control

With the card levered firmly in place, check printer interface control operation as follows:

- 1) Verify that a character printer (either NIP or IMP) is connected in the subsystem and that it is ready for operation (procedure NIP1 or IMP1 in section 6).
- 2) Observe selectable switch settings for correct positions by making use of decal on inside of hood (see figure CRT44 in section 6 for decal) for individual switch identification. If baud rate is set different from that required for the particular printer (NIP uses 300 baud and even parity while the IMP uses 1200 baud and even or odd selectable parity), change switches accordingly.

- 3) Activate PRINT ON LINE key and do all steps of Keyboard Display Checkout (in a previous part of this section) to verify that adding the card did not degrade performance. While doing this, carefully observe section 6 of the diagnostic test mode. The Printer Diagnostic Test Pattern shown in appendix C should print continuously.

CAUTION

Do not allow a printer to constantly print continuous adjacent columns for more than 5 minutes maximum at a time or solenoid assemblies will overheat and be damaged.

Also see that the terminal configuration code display by Test Mode Section 7 (reference CRT58, section 6) indicates that the printer function is present.

- 4) Verify that TEST/NORMAL switch is at NORMAL and press MASTER CLEAR.
- 5) Using the keyboard, compose a short message to exercise the terminal's ability to advance paper, return carriage, backspace, and print. Send such a message to the printer by using, in turn, each of the printer control keys (PAGE PRINT, PRINT ON LINE, and PRINT LOCAL). For instructions on how to compose a message from the keyboard and send it to the printer with each of these three printer control keys, refer to the terminal subsystem operator's guide.
- 6) If any incident occurs to suspect incorrect operation, proceed to section 6 for thorough troubleshooting procedures. Begin troubleshooting at table NIP1, sheet 1, DDLT for Nonimpact Printer.
- 7) When finished checking printer interface control performance, before placing terminal online, verify that TEST/NORMAL switch is at NORMAL and press MASTER CLEAR.

This completes the printer interface control function checkout. Proceed to use the terminal per the particular site requirements. If trouble occurs, use table TS1 in section 6 to begin detailed troubleshooting.

Tape Cassette Unit Interface Control

With the card levered firmly in place, check cassette tape unit interface control operation as follows:

- 1) Verify that a tape cassette unit is connected in the subsystem and that it is ready for operation (procedure TCU1 in section 6).
- 2) Set the device control code enable/disable switch (located at the edge of the card) to desired position.

- 3) Do all steps of Keyboard Display Checkout (in a previous part of this section) to verify that adding the card did not degrade performance. See that the terminal configuration displayed by Test Mode Section 7 (reference figure CRT58, section 6) indicates that the tape unit interface is present.
- 4) Verify that TEST/NORMAL switch is at NORMAL and press MASTER CLEAR.
- 5) Using the keyboard, compose a short message to exercise the terminal's ability to record. Send such a message to each tape drive channel present. For instructions on how to compose a message from the keyboard and send it to the tape unit, refer to the terminal subsystem operator's guide. Appendix C shows a recommended, full-screen, tape unit test pattern, which may be composed and sent to/received from tape units for test exercising.
- 6) Using the tape unit control keys provided on the keyboard, read each message just recorded on each tape drive back to the display screen and visually verify for accuracy.
- 7) If any incident occurs to suspect incorrect operation, proceed to section 6 for thorough troubleshooting procedures. Begin troubleshooting at table TCU1, sheet 1, DDLT for Tape Cassette Unit.
- 8) When finished checking tape unit interface control performance, before placing terminal online, verify that TEST/NORMAL switch is at NORMAL and press MASTER CLEAR.

This completes the tape unit interface control function checkout. Proceed to use the terminal per the particular site requirements. If any trouble should occur, use table TS1 in section 6 to begin detailed troubleshooting.

+5-V Regulator Slave

The +5-V regulator slave card must be installed in the display logic rack when the display's internal demand for +5-V logic power approaches 10 amperes. See specifications in section 1 for the configuration of supplemental functions which may require the +5-V regulator slave.

With the card levered firmly in place, check +5-V regulator slave operation as follows:

- 1) Refer to procedure CRT22 in section 6 and check slave as described there.
- 2) When finished checking performance, before placing terminal online, verify that TEST/NORMAL switch is at NORMAL and press MASTER CLEAR.

Paging

With the paging and extended memory cards levered firmly in place, check paging operation as follows:

- 1) Do all steps of Keyboard Display Checkout (in a previous portion of this section) to verify that adding the card did not degrade performance.
- 2) After placing TEST/NORMAL switch to NORMAL, pressing MASTER CLEAR, and placing ON LINE/LOCAL switch in LOCAL, refer to the terminal subsystem operator's guide and, via the keyboard, exercise the paging functions (two added pages of 1920 characters each). Do this by writing information on the basic page, flipping to the second page and writing on it, and flipping to the third page and writing on it. Flip pages by using TAPE SRCH and TAPE BACKSKIP keys as described in the operator's guide.
- 3) Check that paging functions operate in character, line, block, and format modes (see CHARACTER/LINE/BLOCK and FORMAT switch descriptions in operator's guide).
- 4) If any incident occurs to suspect incorrect operation, proceed to section 6 for thorough troubleshooting procedures. Begin troubleshooting at table CRT11, DDLT for Paging Function in Display Terminal.
- 5) When finished checking paging performance, before placing terminal online, verify that TEST/NORMAL switch is at NORMAL and press MASTER CLEAR.

This completes the paging function checkout. Proceed to use the terminal per the particular site requirements. If any trouble should occur, use table TS1 in section 6 to begin detailed troubleshooting.

NONIMPACT PRINTER INSTALLATION

To install a nonimpact printer, perform the following:

- 1) Remove the unit from shipping/storage container per uncrating procedures.
- 2) Place unit on a clean, sturdy work surface, e.g., desk top in the desired location near the keyboard display. For cooling purposes, provide at least 3 inches (7.6 cm) on either side and back and at least 2 feet (61 cm) above the unit when in its operating location. During installation and checkout, the unit may be in a slid-out location, and then slid back after checkout. Ambient environment must conform with that defined in specifications in section 1.

- 3) Connect the RS-232-C type I/O cable between the printer and controlling keyboard display (see figure 3-11, Subsystem Interconnecting Cables, for cable part number/location). If no tape unit is present in the subsystem, connect this cable to the PERIPHERAL CONNECTOR at the back of the display cabinet. If the tape unit is present, connect this cable to the PRINTER I/O connector at the back of the tape unit cabinet.
- 4) Load/check paper roll in printer (procedure NIP1).
- 5) Plug ac power cord into correct site power outlet (see specifications in section 1).
- 6) Check POWER ON switch on control panel; if lit, press to turn off.
- 7) See Installing Supplemental Function Modules, in a prior part of this section, and verify that printer interface control card is firmly seated in logic rack of display cabinet.

This completes installation procedures for the nonimpact printer. The unit should be ready for checkout as part of the terminal subsystem.

NONIMPACT PRINTER CHECKOUT

To check operation of the nonimpact printer, perform the following:

- 1) Verify ac power cord plugged into site power outlet and printer I/O cable connected.
- 2) Before applying power to printer, lift top cover to check paper supply (procedure NIP1). Also make sure that the PARITY switch (figure 3-11.1) setting has not inadvertently been changed from its installation setting.

NOTE

The PARITY switch is a three-position slide switch located under the paper cover at the front of the paper supply cavity. Sliding the switch to O selects odd parity checking; sliding it to E selects even parity checking; and sliding it to N selects no parity checking. The selection made must coincide with the type of parity used in communications.

- 3) Press POWER ON switch so it lights.
- 4) Press LF switch briefly and observe for continuous paper feed while switch is held down.
- 5) Using the keyboard display, which has been successfully through check-out without the printer attached, check printer operation by doing steps 2 through 5 of Printer Interface Control checkout (in a preceding part of this section).

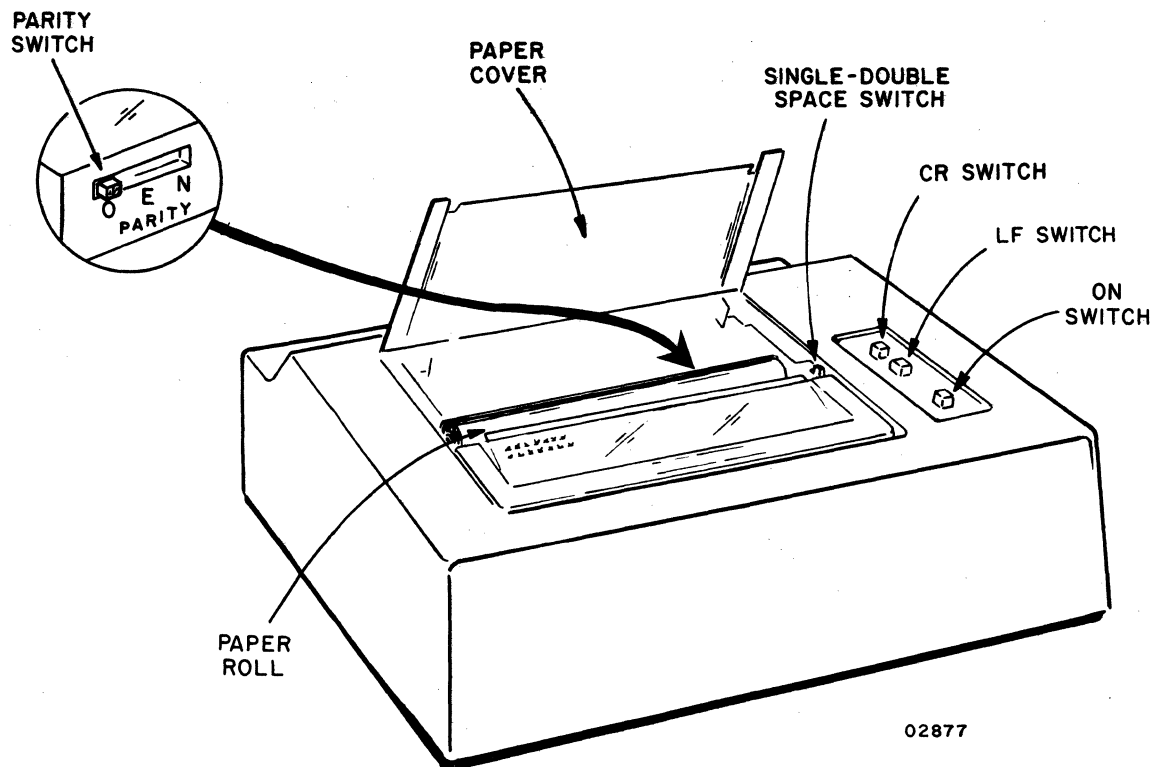

Figure 3-11.1. Nonimpact Printer Controls

- 6) Position the printhead away from the left margin by sending the printer a few characters from the keyboard display and press CR switch to verify that it causes printhead to return to left margin.
- 7) Check for correct single-space and double-space operation of line space switch (two-position, slide switch located under right side of paper cover on printer) by using the switch in each position and sending a multiline print message from the keyboard display.
- 8) If any incident occurs to suspect incorrect operation, proceed to section 6 for thorough troubleshooting procedures. Begin troubleshooting at table NIP1, sheet 1, DDLT for Nonimpact Printer.

This completes checkout for the nonimpact printer. Begin use per site requirements. If trouble occurs use table TS1 in section 6 to begin detailed troubleshooting.

IMPACT PRINTER INSTALLATION

To install an impact printer, perform the following:

- 1) Remove the unit from shipping/storage container per uncrating procedures.
- 2) Place unit on a clean, sturdy work surface, e.g., desk top, in the desired location near the keyboard display. For cooling purposes, but mainly for operator access to machine, provide access space shown in figure 3-12. During installation and checkout, the unit may be slid-out, and then slid back after checkout. Ambient environment must conform with that defined in specifications in section 1.

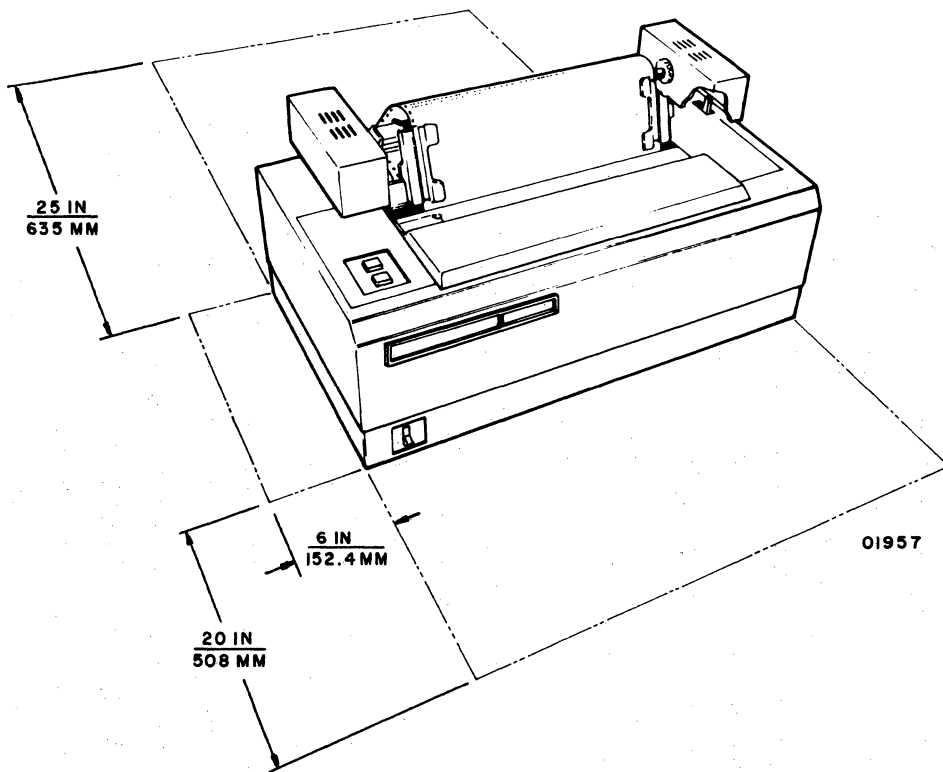

Figure 3-12. Impact Printer Access Space

- 3) Connect the RS-232-C type I/O cable between the printer and the controlling keyboard display (see figure 3-11, Subsystem Interconnecting Cables, for cable part number/location). If no tape unit is present in the subsystem, connect this cable to the PERIPHERAL CONNECTOR at the back of the display cabinet. If the tape unit is present, connect this cable to the PRINTER I/O connector at the back of the tape unit cabinet.
- 4) Open the rear access panel (procedure IMP6, section 6) and verify that all internal cabling is connected, circuit boards in position (figure IMP6, section 6), and no loose items in the cabinet.



- 5) Plug ac power cord into site power outlet which supplies required power (see specifications in section 1).
- 6) Load and align paper (fanfold forms) in printer (procedure IMP3, section 6).
- 7) Install/check ribbon (procedure IMP4, section 6).
- 8) Install/check format tape (procedure IMP5, section 6).
- 9) Check power ON/OFF switch/indicator; if on (lit), toggle to OFF.
- 10) See Installing Supplemental Function Modules, in a prior part of this section, and verify that required printer interface control card is firmly seated in logic rack of display cabinet.

This completes installation procedures for the impact printer. The unit should be ready for checkout as part of the terminal subsystem.

IMPACT PRINTER CHECKOUT

To check operation of the impact printer, perform the following:

- 1) Verify ac power cord plugged into site power outlet and printer I/O cable connected.
- 2) Verify paper, ribbon, and format tape all installed (procedures IMP3, IMP4, and IMP5 respectively).
- 3) Press power ON/OFF switch to ON (switch lights).

NOTE

If cabinet or front access panel is removed, printer will operate only with the interlock switch (white button just behind the control panel) pulled up.

- 4) Activate Test Print switch (located either on control panel or on circuit card 1A02. If on circuit card, open rear access panel per procedure IMP6, section 6 and refer to figure IMP6 to locate switch on card 1A02). Printer should print the character B, alternating with blanks, across the entire page, do a single line feed, and repeat the line of Bs and spaces. This process should continue until Test Print switch is pressed again. Print several lines this way.

CAUTION

Do not allow the printer to constantly print continuous adjacent columns for more than 5 minutes maximum at a time, or solenoid assemblies will overheat and be damaged.

- 5) Use the printed pattern from the preceding step to check vertical and horizontal alignment of characters and lines of printing. For any problems, use table IMP1, sheet 3, DDLT for Impact Printer for troubleshooting.
- 6) With rear access panel open (procedure IMP6, section 6), remove the RS-232-C interface circuit card at location 1A04 (see figure IMP6) and check that all switch and jumper positions on the card conform to the subsystem requirements for the particular site applications. Refer to figure IMP7, section 6 for switch/jumper locations and definitions.
- 7) With cabinet fully in place, rear access panel closed, and front access panel in place — press ON/OFF switch/indicator to ON (it lights) and press START/STOP switch/indicator so it lights. The printer should be ready for subsystem operation.
- 8) Using the keyboard display which has been successfully through checkout without the printer attached, check printer operation by doing steps 2 through 5 of Printer Interface Control checkout (in a preceding part of this section).
- 9) If any incident occurs to suspect incorrect operation, proceed to section 6 for thorough troubleshooting procedures. Begin troubleshooting at table IMP1, sheet 1, DDLT for Impact Printer.

This completes checkout for the impact printer. Proceed to use it per the particular site requirements. If trouble occurs, use table TS1 in section 6 to begin detailed troubleshooting.

TAPE CASSETTE UNIT INSTALLATION

To install a tape cassette unit, perform the following:

- 1) Remove the unit from shipping/storage container per uncrating procedures.
- 2) Place unit on a clean, sturdy work surface, e.g., desk top, in the desired location near the keyboard display. For cooling purposes, be sure to provide at least six inches (15.2 cm) at both back and front of unit and at least two feet (61 cm) above the unit when in its operating location. During installation and checkout, the unit may be slid-out, and then slid back after checkout. Ambient environment must conform with that defined in specifications in section 1.

- 3) Connect the RS-232-C type I/O cable between the tape unit and the PERIPHERAL CONNECTOR at the back of the controlling keyboard display (see figure 3-11, Subsystem Interconnecting Cables, for cable part number/location). If no printer (NIP or IMP) is present in the subsystem, only this one cable is required. If one of the printers is present, it will be connected via another cable from the tape unit (see particular printer installation procedures in a preceding portion of this section).
- 4) Open the cabinet hood (procedure TCU4, section 6) and verify that all internal cabling is connected, circuit boards firmly in position (figure TCU3), and no loose items in the cabinet. Replace hood (procedure TCU4).
- 5) Plug ac power cord into site power outlet which supplies required power (see specifications in section 1).
- 6) For 50-Hz units only — if primary input power to the terminal, from the site power source, measures between 195 and 246-V ac, slide INPUT VOLTAGE RANGE SWITCH (figure 3-8) to the LOW LINE position. If input power measures between 216 and 268-V ac, slide INPUT VOLTAGE RANGE SWITCH to the NORMAL position.
- 7) See Installing Supplemental Function Modules for the keyboard display (in a preceding portion of this section) and verify required tape cassette unit interface control card installed in logic rack of display cabinet.

This completes installation procedures for the tape cassette unit. The unit should be ready for checkout as part of the terminal subsystem.

TAPE CASSETTE UNIT CHECKOUT

To check operation of the tape cassette unit, perform the following:

- 1) Verify ac power cord plugged into site power outlet and cabinet I/O cable to keyboard display connected, but keyboard display turned off.
- 2) Place white, toggle-type breaker switch on rear panel to up position. Observe control panel lights for following:
 - READ and WRITE amber lights glow.
 - POWER 1 and 2 green lights glow (both on dual unit only).
- 3) Load one scratch cassette tape if unit has a single drive or two scratch tapes if unit has two drive units. Close covers and observe control panel lights for following:
 - READ and WRITE amber lights still glowing.
 - POWER green light(s) still glowing.

- 4) While observing tape cassette unit control panel lights, switch keyboard display power on. The following should occur:
 - a) READ and WRITE amber lights go out.
 - b) POWER green light(s) remain on.
 - c) TAPE OUT red light goes on for each tape drive unit present while tape positions to start point.
 - d) TAPE OUT red light(s) extinguish.
 - e) READY green light goes on for each tape drive unit present and stays on.
- 5) Press UNLOAD switch (with connected keyboard display still on) and observe that tape in the drive rewinds to clear leader and stops.
- 6) Using the keyboard display which has been successfully through checkout without the tape cassette unit attached, check tape unit operation by doing steps 2 through 6 of Tape Cassette Unit Interface Control checkout (in a preceding part of this section).
- 7) If any incident occurs to suspect incorrect operation, proceed to section 6 for thorough troubleshooting procedures. Begin troubleshooting at table TCUI, sheet 1, DDLT for Tape Cassette Unit.

This completes checkout for the tape cassette unit. Proceed to use it per the particular site requirements. If trouble occurs, see table TS1 in section 6, to begin detailed troubleshooting.

COMPLETE TERMINAL SUBSYSTEM INSTALLATION AND CHECKOUT

To complete the installation and checkout of any version terminal subsystem, first install and check each cabinet/equipment separately (including any supplemental functions which are part of the display cabinet). Do this by following the appropriate procedures which appear previously in this section.

After doing all applicable checkout procedures at the installed subsystem level, place the subsystem online with the communications system, e.g., via the site modem, and using the system-required protocol, exercise/check communications capability between the system and the subsystem just installed by you. With help as necessary from the customer's site personnel, verify all customer requirements for the subsystem.

If there is any reason to suspect that the terminal subsystem is not operating properly, proceed to section 6 for thorough troubleshooting procedures. When going to section 6, if the failure does not specifically point to a certain portion of the subsystem, e.g., display failure, printer failure, etc., begin detailed troubleshooting at table TS1, sheet 1, DDLT for Terminal Subsystem. If the failure definitely, or with high probability, points to a certain equipment, go to the DDLT for that equipment, e.g., CRT cabinet, printer, or tape unit.

This section identifies and isolates a malfunction in the terminal to a replaceable module, or where equipment design does not permit this, to a replaceable subassembly, part, or cable. It also lists corrective actions and, where necessary, includes procedures to carry out a corrective action. This section's main diagnostic tool is the decision logic table, which is described later. First, however, is a discussion of the approach to emergency maintenance, which is followed by the preventive maintenance tasks that the customer engineer must perform during emergency maintenance.

EMERGENCY MAINTENANCE

The following is a suggested procedure that a customer engineer should follow when responding to a customer's complaint or request for service. First, before leaving for the customer's site, he should call the customer contact and determine, if possible, the extent of the problem and whether it concerns the crt display, tape cassette, or printer, and, if the printer, ask which type of printer it is. Then, he should refresh his knowledge of the equipment by reviewing the available documentation on the terminal (see preface for a list of manuals). He should especially note which parts are provided as spares on site (see Spare Parts List, volume 1, section 8) and which tools and equipment he will need (see Maintenance Aids, this section).

Upon arriving at the customer's site, the customer engineer should again talk to the customer contact and ask for directions to and identification of the malfunctioning equipment. If the person who initiated the complaint is available, the customer engineer should interview that person.

Based on what he learns, the customer engineer can then proceed in one of two ways. If he has the knowledge and the familiarity with the terminal to recognize that a specific trouble points to a particular equipment in the system, he could go to the diagnostic decision logic table for that equipment and begin troubleshooting, using the table. Otherwise, he could start from scratch and perform a complete check of the terminal. To do this, he starts with the first diagnostic decision logic table for the terminal subsystem, completes the table, and continues with the tables for the keyboard display, printer, and/or tape cassette unit in that order until he corrects the fault.

Regardless of which method he chooses, the customer engineer should first walk around the terminal and visually inspect it for loose cables or connectors, damaged cables, burnt or broken insulation, excessive dirt, etc. He should also note whether any component smells burnt or is overheating.

CAUTION

Since the circuits throughout this subsystem use MOS type integrated circuit chips which may be destroyed by excess static electric charge, always observe MOS circuits handling procedures (see appendix C) when connecting/disconnecting any cabinets, modules, components, or parts of/in the subsystem.

Finally, after correcting the problem, the customer engineer should always perform preventive maintenance as outlined in the following paragraphs. After completing preventive maintenance, he should verify that the system is fully operational by running all diagnostics. Before leaving, he should again talk to the customer contact. And, more importantly, the customer engineer should never leave the site without first receiving assurance that he has satisfied the customer.

PREVENTIVE MAINTENANCE

Preventive maintenance describes those tasks that shall be performed during emergency (corrective) maintenance by the one answering the emergency maintenance call. A preventive maintenance task (PMT) table and preventive maintenance task procedures (PMTTP) describe those tasks for each cabinet which may be part of a subsystem. Also, the one answering the emergency maintenance call must verify that the equipment operator has been performing the preventive maintenance tasks that are his, or her, responsibility (the operator's guide describes these tasks) at least once a month under normal operating conditions in an office environment such as that found in most commercial banks.

KEYBOARD DISPLAY PMTs

The listing of PMTs, table 6-1, defines the items to be performed or checked at the keyboard display each time the terminal requires repair. Do these tasks for best equipment performance and to reduce failures.

CAUTION

Do not use solvents to clean keyboard. Solvents can cause defective key-switch operation.

TABLE 6-1. KEYBOARD DISPLAY PMTs

ITEM	PROCEDURE	APPROXIMATE TIME (MINUTES)
1	Clean keyboard	2
2	Clean exterior surface	2
3	Clean viewing screen	2
4	Visually inspect all cables and wires for insulation breakdown or other damage	5
5	Check keycaps for signs of wear or breakage	1
6	Check for foreign objects inside cabinet	5

KEYBOARD DISPLAY PMTPs

The following test describes the PMTPs which support the preceding PMT table for the keyboard display.

CAUTION

Before working inside cabinet for these PMTPs, turn power off and pull cord from site power outlet.

- 1) Remove dust from keyboard with a soft-bristled brush.

CAUTION

Do not use solvents or cleaning fluids.

- 2) Clean exterior surfaces of cabinet with a damp, lint-free cloth. Mild detergent may be used.
- 3) Clean face of viewing screen with a clean, soft cloth and a mild glass-cleaning solution. If a spray is used, do not allow liquid to flow off screen (it is preferable to spray cloth rather than screen).

- 4) Remove cabinet hood (procedure CRT21), and visually inspect all cables and wires for evidence of insulation breakdown and wear. Replace damaged wires if possible. Check electrical connections to ensure they are not loose. Check electronic components for signs of deterioration, such as overheating or aging.
- 5) Check keycaps for signs of wear or breakage and replace keyboard if necessary (procedure CRT18).
- 6) Check for foreign objects such as bits of wire or solder.

NONIMPACT PRINTER PMTs

The PMTs listed in table 6-2 are the tasks to be done at the nonimpact printer (if part of the subsystem) at the intervals specified in the table. Do these tasks for best equipment performance and to reduce repairs.

TABLE 6-2. NONIMPACT PRINTER PMTs

LEVEL (SEE NOTES)	ITEM	PROCEDURE	APPROXIMATE TIME (MINUTES, SEE NOTES)
1	1.1	Clean exterior surface	2
1	1.2	Inspect cabinet interior for possible loose parts	3
1	1.3	Clean cabinet interior	5
1	1.4	Inspect all cables and wires for insulation breakdown or other damage	2
1	1.5	Inspect all mechanisms for signs of excess wear	3
1	1.6	Check carefully for foreign objects inside cabinet and mechanism	2
2	2.1	Clean printhead	15
2	2.2	Clean guidebar	5
2	2.3	Lubricate platen solenoid plunger	5

Notes:

- 1) Level 1 tasks are those to be done each time the terminal subsystem requires repair. Level 2 tasks are required every 20 million printed characters, 500,000 line feeds, or one year — whichever occurs first. However, if foreign material is suspected on the guidebar at any time, it should be cleaned to prevent excessive carriage return time (over 200 milliseconds). Also, if printhead contamination is suspected before the normal cleaning time, it should be cleaned.
- 2) Approximate time given is for tasks listed here only and does not include troubleshooting/corrective maintenance procedures which may be seen as necessary from these PMTs.

NONIMPACT PRINTER PMTPs

Following text describes the PMTPs which support the preceding PMT table for the nonimpact printer.

CAUTION

Before working inside cabinet for these PMTPs, turn power off and pull cord from site power outlet.

The following steps describe the level 1 tasks listed in the PMT table.

- 1.1) Clean exterior surfaces of cabinet with damp, lint-free cloth. Mild detergent may be used. Do not use cloth so wet that water runs down into printer.
- 1.2) Turn the two hood-locking screws at cabinet rear 1/4-turn counter-clockwise and pull these screws back. Lift hood up from back until it will slide forward off its front holding tab. Placing the hood aside, inspect interior of cabinet for possible parts which may have worked loose from mechanism. Replace parts, or mechanism, depending on whether loose parts are reusable, replaceable, etc.
- 1.3) Using a soft, long-bristled brush and vacuum cleaner with a crevice tool, carefully and thoroughly clean cabinet interior of any/all paper particles, dust, etc.
- 1.4) Inspect all cables, wires, and connections (including I/O connector pins) for evidence of insulation breakdown or wear. Repair/replace damaged wires if possible. Check electronic components for signs of deterioration such as overheating or aging.
- 1.5) Look carefully at all mechanisms for signs of wear. Repair/replace worn parts if possible (use replacement procedures provided later in this section).
- 1.6) Inspect for foreign objects possibly lodged in crevices within the mechanism or other portions of cabinet.

The following steps describe the level 2 procedures listed in the PMT table. However, perform all level 1 tasks before doing level 2.

2.1) Clean printhead as follows:

- a) Remove printhead and cable assembly from printer (procedure NIP13).
- b) Using a clean, dry, stiff-bristle toothbrush, brush 10 to 15 times across printhead elements in both vertical and horizontal directions.

CAUTION

Do not use solvents or cleaning fluids.

- c) Replace printhead and cable assembly in printer (procedure NIP13).

2.2) Clean guidebar as follows:

- a) Using a clean, dry, lint-free cloth, wipe all four sides of the head guidebar until clean. Move carriage as necessary to access bar along entire length.

CAUTION

Do not use solvents or cleaning fluids.

- b) Exercise printer for a few minutes, e.g., do Nonimpact Printer Checkout, section 3, and repeat wiping guidebar.

2.3) Lubricate platen solenoid plunger (figure NIP7) as follows:

- a) Apply three drops of CDC 62148158 lubricant, or equivalent, around plunger working surface.
- b) Operate plunger in and out of housing to distribute lubricant.

IMPACT PRINTER PMTs

The PMTs listed in table 6-3 are the tasks to be done at the impact printer (if a part of the subsystem) at the intervals specified in the table. Do these tasks for best equipment performance and to reduce repairs.

TABLE 6-3. IMPACT PRINTER PMTs

LEVEL (SEE NOTES)	ITEM	PROCEDURE	APPROXIMATE TIME (MINUTES, SEE NOTES)
1	1.1	Clean exterior surface	3
1	1.2	Inspect cabinet interior for possible loose parts	5
1	1.3	Clean cabinet interior	5
1	1.4	Inspect all cables and wires for insulation breakdown or other damage	4
1	1.5	Inspect all mechanisms for signs of excess wear	5
1	1.6	Check carefully for foreign objects inside cabinet and mechanism	4
2	2.1	Oil drive mechanism	2
2	2.2	Grease bevel gears	2
2	2.3	Examine/replace return reel cord	2 to 10
2	2.4	Clean printhead-slide shafts	2
2	2.5	Oil format tape and forms motion motor	1
2	2.6	Use printer's Test Print switch and exercise	5
2	2.7	Replace cabinet and pack tools/materials	10
3	3.1	Remove and wash printhead and then check print pins	30
3	3.2	Reinstall printhead	10
3	3.3	Use printer's Test Print switch and exercise	5
3	3.4	Replace cabinet and pack tools/materials	15

Notes:

- 1) Level 1 tasks are those to be done each time the terminal subsystem requires repair. Level 2 tasks are required every 13.2 million printed characters, 500 hours of power-on time, or 3 months — whichever comes first. Level 3 tasks are required every 79.2 million characters, 3000 hours of power on time, or 18 months — whichever comes first. However, if inspection shows the level 2 or 3 tasks should be done ahead of schedule, of course, do such tasks as seem necessary to help prevent equipment wear/misperformance.
- 2) Approximate time given is for tasks listed here only and does not include troubleshooting/corrective maintenance procedures which may be seen as necessary from these PMTs.

IMPACT PRINTER PMTPs

The following text describes the PMTPs which support the preceding PMT table for the impact printer.

CAUTION

Before working inside cabinet for these PMTPs, turn power off and pull cord from site power outlet.

The following steps describe the level 1 tasks listed in the PMT table.

- 1.1) Clean exterior surfaces of cabinet with damp, lint-free cloth. Mild detergent may be used. Do not use cloth so wet that water runs down into printer.
- 1.2) Remove cabinet (procedure IMP6). With cabinet placed aside, inspect interior cabinet base and horizontal surfaces for possible parts which may have worked loose from mechanism. Replace parts, or mechanism, depending on whether loose parts are reusable, replaceable, etc.
- 1.3) Using a soft, long-bristled brush and vacuum cleaner with a crevice tool, carefully and thoroughly clean cabinet interior of any/all paper particles, dust, etc.
- 1.4) Inspect all cables, wires, and connections (including I/O connector pins) for evidence of insulation breakdown or wear. Repair/replace damaged wires if possible. Check electronic components for signs of deterioration such as overheating or aging.
- 1.5) Look carefully at all mechanisms for signs of wear. Repair/replace worn parts if possible (use replacement procedures provided later in this section).
- 1.6) Inspect for foreign objects possibly lodged in crevices within the mechanism or other portions of the equipment.

The following steps describe the level 2 tasks listed in the PMT table. However, perform all level 1 tasks before doing level 2.

2.1) Oil drive mechanism as follows:

- a) Put three drops of oil, part no. 95011200, in oil hole in motor support casting, figure IMP11.
- b) Put one drop same type oil in oil hole in each support bearing (two) of drive shaft.

CAUTION

Do not allow any oil in the clutch mechanism.

2.2) Grease bevel gears as follows:

- a) Smear molygrease, part no. 12210957, on bevel gears of ribbon drive (figure IMP11) as required.

2.3) Inspect return reel cord for fraying and, if frayed, replace (procedure IMP17).

2.4) Clean printhead-slide shafts as follows:

- a) Using a clean, dry, lint-free cloth, wipe shafts until clean. Move printhead carriage as necessary to access shafts along entire length.

CAUTION

Do not use solvents or cleaning fluids.

- b) Apply four drops oil, part no. 95011200, to each felt washer which rides on shafts.
- c) Move printhead carriage from end-to-end of shafts several times, then wipe shafts clean again.

2.5) Oil Format tape and forms motion motor as follows:

- a) Apply one drop oil, part no. 95011200, to oil hole for felt lubricating pad, figure IMP11.

2.6) Do Test Print exercise as follows:

- a) See that paper is loaded (procedure IMP3) and ribbon is ready.
- b) With power cord plugged into site power outlet, press ON/OFF switch to turn printer on (switch illuminated).
- c) Pull safety switch up (figure IMP11).
- d) With printer offline (START/STOP switch not lit), activate Test Mode switch. Printer should continuously print alternating sets of the character "B" followed by an equal number of space characters. This should occur for a line, the paper should advance one line, and the process should continuously repeat until Test Switch is deactivated.

CAUTION

Do not allow the printer to constantly print continuous adjacent columns for more than 5 minutes maximum at a time, or solenoid assemblies will overheat and be damaged.

- e) Examine printout for print quality (light or missing dots or improper character width). If any problem exists, refer to table IMP1, DDLT for Impact Printer.

2.7) If not doing level 3 tasks, or any other maintenance at this time, replace printer cabinet (procedure IMP6) and pack tools/materials.

The following steps describe the level 3 tasks listed in the PMT table. However, perform all level 1 tasks and the first five level 2 tasks before doing level 3.

3.1) Remove and wash printhead and check print pins as follows:

- a) Remove printhead from printer (procedure IMP17).
- b) Wash residue from printhead using standard isopropyl alcohol normally used for cleaning.
- c) Use a magnifying device such as an eye-loupe and inspect print pins for being flush with surface of ruby guide. If not flush, return printhead to repair facility and use a replacement in the printer.

- 3.2) Reinstall printhead in printer (procedure IMP17).
- 3.3) Do Test Print exercise as described in level 2 step 2.6.
- 3.4) If not doing any other maintenance at this time, replace printer cabinet (procedure IMP6) and pack tools/materials.

TAPE CASSETTE UNIT PMTs

The PMTs listed in table 6-4 are the tasks to be done at the tape cassette unit, either single or dual drive (if either is a part of the subsystem), at the intervals specified in the table. Do these tasks for best equipment performance and to reduce repairs.

TABLE 6-4. TAPE CASSETTE UNIT PMTs

LEVEL (SEE NOTES)	ITEM	PROCEDURE	APPROXIMATE TIME (MINUTES, SEE NOTES)
1	1.1	Clean exterior surface	2
1	1.2	Clean read/write head(s) and capstans	5 to 10
1	1.3	Inspect cabinet interior for possible loose parts	3
1	1.4	Clean cabinet interior	5
1	1.5	Inspect all cables and wires for insulation breakdown or other damage	3
1	1.6	Inspect all mechanisms for signs of excess wear	2 to 5
1	1.7	Check carefully for foreign objects inside cabinet or mechanisms	2
2	2.1	Replace tape drive module (both drives if dual-drive unit) and send old drive(s) in for detailed preventive maintenance adjustments, lubrication, and servicing. This is not normally intended as on-site or field type work. However, if desirable to do this detailed servicing of the drives on-site, refer to the Tape Cassette Mechanism Hardware Maintenance Manual (see preface of this manual for publication number) and follow the maintenance procedures given there	10 to 20

Notes:

- 1) Level 1 tasks are those to be done each time the terminal subsystem requires repair. Level 2 tasks are required every 700,000 start/stops, 290,000 feet of tape, or 12 months — whichever comes first. However, if inspection shows that a tape drive module may be out of adjustment or otherwise not performing correctly, replace it or see that it gets the required detailed maintenance performed on it.
- 2) Approximate time given is for tasks listed here only and does not include troubleshooting/corrective maintenance procedures which may be seen as necessary from these PMTs.

TAPE CASSETTE UNIT PMTPs

The following text describes the PMTPs which support the preceding PMT table for the tape cassette unit.

CAUTION

Before working inside cabinet for these PMTPs, turn power off and pull cord from site power outlet.

The following steps describe the level 1 tasks listed in the PMT table.

- 1.1) Clean exterior surfaces of cabinet with damp, lint-free cloth. Mild detergent may be used. Do not use cloth so wet that water runs down into unit.
- 1.2) Using soft swabs and cloths, clean read/write head(s) and capstans (procedure TCU14).
- 1.3) Remove cabinet hood (procedure TCU4). With hood placed aside, inspect interior cabinet base and horizontal surfaces for possible parts which may have worked loose from mechanism. Replace parts, or mechanism, depending on whether loose parts are reusable, replaceable, etc.
- 1.4) Using a soft, long-bristled brush and vacuum cleaner with a crevice tool, carefully and thoroughly clean cabinet interior of any/all particles, dust, etc.
- 1.5) Inspect all cables, wires, and connections (including I/O connector pins) for evidence of insulation breakdown or wear. Repair/replace damaged wires if possible. Check electronic components for signs of deterioration such as overheating or aging.
- 1.6) Look carefully at all mechanisms for signs of wear. Repair/replace worn parts if possible (use replacement procedures provided later in this section).
- 1.7) Inspect for foreign objects possibly lodged in crevices within the mechanism or other portions of the equipment.

The following steps describe the level 2 tasks listed in the PMT table. However, perform all level 1 tasks before doing level 2.

2.1) Replace (or service) tape drive module(s) as follows:

- a) Remove tape drive module(s) from tape unit cabinet (procedure TCU12).
- b) Either pack old tape drive module(s) per Crating in section 3 and ship in for servicing or, if equipped properly, refer to the Tape Cassette Mechanism Hardware Maintenance Manual (publication number given in preface of this manual) and perform detailed preventive maintenance described therein.
- c) Install either new or serviced tape drive module(s) in tape unit cabinet (procedure TCU12).

MAINTENANCE AIDS

The following special tool is required to maintain the crt display.

- 3/32-inch nonmetallic hex driver (CRT Tuning Wand, Part No. 12263299)

DIAGNOSTIC AND CORRECTIVE MAINTENANCE

Maintenance activity for the terminal subsystem falls into two general categories which are commonly termed diagnostic maintenance and corrective maintenance. Diagnostics for this subsystem fall into two specific classes which are: 1) automatic, internally-resident test mode, and 2) manually-executed, step-by-step fault isolation. Corrective maintenance for the subsystem consists of those tasks, adjustments, removal and replacement, etc. activities which may be required to correct any diagnosed fault. The following information in this section thoroughly describes such diagnostics and corrective maintenance procedures.

CAUTION

Since the circuits throughout this subsystem use MOS type integrated circuit chips which may be destroyed by excess static electric charge, always observe MOS circuits handling procedures (see appendix C) when connecting/disconnecting any cabinets, modules, components, or parts of/in the subsystem.

SUBSYSTEM TEST MODE DIAGNOSTIC

The keyboard display logic rack hosts a test mode diagnostic program which does a series of short, self-diagnostic exercises (test sections) of a large portion of the terminal hardware. The program resides in nonvolatile ROM in the logic rack and is manually initiated as follows:

- 1) Power on
- 2) TEST/NORMAL switch in TEST position
- 3) Press MASTER RESET

or:

- 1) TEST/NORMAL switch in TEST position
- 2) Initial power application

The test mode will manually step through the following test sections:

- 0 (Checksum ROM) — Looks for a 00 sum as the add results of each 256-byte segment of ROM. Each of the 16 segments should have 00 checksum displayed following the beginning address of the segment. If no errors are present in any segment, the ALERT indicator lights and the Test 0 routine continues to cycle. Exit from the test by pressing any alphanumeric key. If error is found, alarm sounds, and test stops after displaying non-zero add results of the first segment which has an error found in it. Pressing lowercase q advances the ROM test through the remaining segments and pressing uppercase Q stops the alarm and advances the test to Section 1.
- 1 (Check RAM) — Loads all locations in RAM (full-page) with a character and reads (displays) it to ensure proper operation. This repeats for each of the 128 characters in the display repertoire (includes the 32 control characters). Then the action repeats, but with a blinking cursor appearing under every other character. If no error occurs, ALERT lights and test continues cycling. Exit from this test by pressing any alphanumeric key. If an error occurs, alarm sounds, and test stops leaving the character in error displayed. Pressing Q key stops alarm and advances the test to Section 2.
- 2 (Shifting Pattern and I/O) — Transmits characters, one-at-a-time, starting with 041g (exclamation character) and incrementing by one through 137g (underline character). This process repeats constantly. Each character transmitted is looped back to the communications line receivers and as such is entered into RAM and displayed until the screen is full. Each display character is checked to verify that transmitted characters are received correctly. If no errors are present, ALERT lights and test routine continues to cycle. Exit from test by pressing any alphanumeric key. If error occurs, alarm sounds and test halts. Pressing Q key stops alarm and advances the test to Section 3.

- 3 (Keyboard Data Entry) — Each displayable key on the keyboard enters the associated character in every character position on the display screen. Verification of proper operation is by visual observance (reference appendix for displayable keycode repertoire). Exit from this test by pressing the spacebar key twice; however, if a printer is part of the subsystem, activate (depress) PRINT ON LINE key before stepping ahead with the two spacebar depressions.
- 4 and 5 (Not assigned)
- 6 (Printer Test) — Transmits lines of 79 characters to the printer via the printer interface control card in the keyboard display logic module. At the end of each line, transmits a carriage return code followed by a new line code. The lines of 79 characters begin with a space (040₈ code) and increment through 176 code (tilde character) and keep repeating this pattern.

CAUTION

Do not allow an impact printer to continuously print adjacent columns for more than 5 minutes maximum at a time or solenoid assemblies will overheat and be damaged. Press any alphanumeric key to exit this subsystem printer test.

Verify proper operation by comparing the printout with Printer Diagnostic Test Pattern in appendix C. Exit from this test by pressing any alphanumeric key.

- 7 (Terminal Configuration) — Displays a hexadecimal number consisting of four groups of two digits each. Each 2-digit group may be looked at as an 8-bit binary code. This 8-bit binary code is the key to what any given configuration displayed actually means. Each bit of each 8-bit binary code (represented in hexadecimal on the display) indicates either the active setting of some individual switch or the presence of some individual functional module (card/peripheral) in the terminal subsystem. This hexadecimal configuration code is dynamically displayed (updates to proper code automatically as any applicable change occurs such as changing a switch setting while the code showing the switch condition is being displayed). Figure CRT58 shows/defines all bit-position meanings for the configuration code. Refer to and use this figure when reading the code displayed on the screen.

IMPACT PRINTER TEST PRINT DIAGNOSTIC

The impact printer available as a peripheral character printer in the subsystem hosts a short diagnostic program which causes the printer to print the character "B" alternating with blanks across the 132 column page, perform a single line advance, and repeat this process for as long as TEST PRINT switch is active. Appendix C contains an example of this Impact Printer TEST PRINT Pattern. The program for this print test resides in nonvolatile ROM in the logic rack of the printer and is manually initiated as follows:

- 1) Power on.
- 2) Ribbon, format tape, and paper loaded.
- 3) START/STOP switch inactive (not lit).
- 4) Press TEST PRINT switch so it lights.

The printer should be printing the TEST PRINT pattern just defined. To stop the continuous printout of this test pattern, press TEST PRINT switch again so it extinguishes.

DIAGNOSTIC TABLES

The key for isolating a subsystem fault/problem to its probable cause is proper use of the cookbook type diagnostic tables which follow in this section. These tables, termed diagnostic decision logic tables (DDLT's), or simply decision tables, identify and isolate a malfunction in the equipment to a replaceable module or, where equipment design does not permit this, to a replaceable subassembly, part, or cable. The tables include references to test-mode operation and corrective procedures as applicable. There is a separate set of tables and repair procedures for each cabinet-level equipment(s) of the terminal subsystem, i.e., keyboard display terminal, impact printer, nonimpact printer, and tape cassette unit. Note that supplemental functions to the keyboard display cabinet (sometimes termed options even though they may be a basic part of a customer's subsystem) are included as part of the tables for the keyboard display terminal even though they have their own separate function/equipment designations. This inclusion is done because of their close functional relationship to the keyboard display circuits and their physical location within the keyboard display terminal cabinet.

Anyone totally unfamiliar with the terminal subsystem should begin with the first sheet of the DDLT's for the subsystem and continue through each DDLT for each cabinet and do so in the order directed by the DDLT's.

What is a diagnostic decision logic table? The diagnostic decision logic table is a specialized format for displaying logic in a way that is superior to the conventional logic flowchart because the logic is more visible. Figure 6-1 is an example of a diagnostic decision logic table (note that the example chosen is for a card reader of a different system. It was selected and used here merely for the purpose of

VISUAL CHECKS											
ASSUME											
Card-reader power cord is connected to ac outlet. Power is on. If power is not on, see procedure 1.											
CONDITIONS	SITUATIONS										
	1	2	3	4	5	6	7	8	9	10	11
Is POWER ON indicator illuminated?	Y	N	N	N	Y	Y	Y	Y	Y	Y	O T H E R
Cycle rear-panel toggle switch S1. Press READ CHECK indicator/switch. Do all other indicators illuminate?	Y	N	N	Y	N	N	Y	Y	Y	Y	
Do any indicators illuminate?	-	N	N	-	N	Y	-	-	-	-	
Press and release RESET indicator/switch. Is RESET indicator illuminated?	Y	-	-	-	-	-	N	Y	Y	Y	
Do all three motors start when RESET indicator/switch is pressed (observe card-feed drum and coils of stacker motors)?	Y	-	-	-	-	-	-	N	N	Y	
Do any motors start?	-	N	Y	-	-	-	-	Y	N	-	
Did motor power drop within 10 to 30 seconds after releasing RESET indicator/switch?	Y	-	-	-	-	-	-	-	-	N	
ACTIONS	SEQUENCE										
Go to sheet 2, Electromechanical Checks.	X	-	-	-	-	-	-	-	-	-	-
Check that toggle switch S1 (rear panel) is up.	-	1	-	-	-	-	-	-	-	-	-
Check that removable power cord is connected securely to card reader.	-	2	-	-	-	-	-	-	-	-	-
Check fuses (rear panel).	-	3	-	-	-	-	-	-	-	-	-
Check switch board and associated cabling (procedure 40). Replace, if required (procedure 41).	-	4	-	2	2	2	3	-	-	-	-
Refer to CB10X manual.	-	5	4	4	3	4	5	3	3	3	-
Check +17-volt power supply (procedure 36).	-	-	1	-	-	-	-	-	-	-	-
Check for +17-V dc between ground and control-board connector P2, pins 2 and 3 and between ground and switch board connector, pins 2 and 3 (two pins joined by foil).	-	-	2	-	-	-	-	-	-	-	-
Check cable between control board and switch board.	-	-	3	-	-	-	-	-	-	-	-
Replace lamp in failing indicator (procedure 41).	-	-	-	1	-	1	-	-	-	-	-
Check failing indicator and/or switch (procedure 40) and replace, if required (procedure 41).	-	-	-	3	-	3	-	-	-	-	-
Check READ CHECK indicator/switch (procedure 40) and replace, if required (procedure 41).	-	-	-	-	1	-	-	-	-	-	-
Check +5-volt power supply (procedure 35).	-	-	-	-	-	-	1	-	-	-	-
Check RESET indicator/switch (procedure 40) and replace, if required (procedure 41).	-	-	-	-	-	-	2	-	-	-	-
Replace control board (procedure 44).	-	-	-	-	-	-	4	-	2	2	-
Check for ac power at motor connectors (procedure 37).	-	-	-	-	-	-	-	1	-	-	-
Check failing motor. Replace motor, if required (procedure 46 for card-feed motor, or procedure 47 for card-stacker motor).	-	-	-	-	-	-	-	2	-	-	-
Check common cable connections to motors.	-	-	-	-	-	-	-	-	1	-	-
Check that T0 switch (control board) has labeled side, T0, up.	-	-	-	-	-	-	-	-	-	1	-
Call next level of support.	-	-	-	-	-	-	-	-	-	-	X

Figure 6-1. Example of a Diagnostic Decision Logic Table

explanation). The value of the DDLT is that it analyzes a situation down to specific conditions and then directs the customer engineer to those actions that will correct the situation, with the most likely action listed first. Basically, the table is arranged in four sections, or quadrants. These quadrants are called Conditions, Situations, Actions, and Sequence of Actions.

Conditions

The upper-left quadrant of a DDLT contains the test conditions and questions that can be answered yes or no. It also includes any basic assumptions, such as "Power cord is connected to ac outlet."

Situations

The upper-right quadrant contains vertical columns, called situations, each summarizing a unique set of conditions. Each column allows one to analyze each set of conditions, point-by-point, to find a set that matches the existing situation. Note that each test condition, or question, can be answered with a yes (Y) or a no (N).

An irrelevant condition has a hyphen (-) in its respective answer block. The example chosen has 11 unique situations, numbered from 1 to 11, left to right. The shaded area in the example shows the four conditions that define situation number two. That is, the POWER ON indicator does not illuminate; all other indicators do not illuminate when READ CHECK indicator/switch is pressed; no single indicator illuminates; and no motors start.

When using the tables, search for the vertical column that contains the exact conditions that match the existing situation, beginning at the left and examining all conditions in the first column before moving to the right and the next column. Any overriding condition or situation always appears first. Here, in the example, column 1 identifies an everything-is-normal situation for the tests made. Therefore, the Actions quadrant in the lower left of the table directs the customer engineer to "Go to sheet 2, Electromechanical Checks." The customer engineer then goes to sheet 2 of the table and does not waste time with further examination of sheet 1. (Note that an "X" is used in the Actions quadrant when it is the only action to be taken.)

Actions

The lower-left quadrant lists actions to correct a situation.

Sequence of Actions

The lower-right quadrant lists the sequence of the actions required to correct a situation with the second, third, fourth, and succeeding actions being performed only if a previous action failed to remedy a problem situation. In general, the numerical sequence of actions reflects the probability of the corresponding action correcting the problem. However, this is weighted by the situation where a less probable remedial action is much quicker to perform than the more probable remedial action. Therefore, it may be more expedient in terms of time to first do the much quicker action in hopes that it may solve the problem. Thus, the order of actions is often a result of careful consideration between the most probable remedy and the quickest action which has a reasonable probability of being the remedy.

Both actions and conditions may refer to specific procedures to follow — for example, when checking and adjusting power supply voltages. The customer engineer must exit the table to perform the procedure and then return to the same point in the table to answer any questions that are related to the procedure. He also continues from this point in the table if the fault still persists. The same is true if an exit to another table or sheet of the same table does not find the fault and the action that called for the exit is not the last action in the sequence. The customer engineer must return to his original exit point and continue testing from there.

NOTE

When the POWER ON/OFF switch is turned OFF, it should not be turned ON again before 60 seconds or the circuit breaker may trip.

GENERAL INSTRUCTIONS

If you are unfamiliar with the terminal and the diagnostic decision logic table, read the text (in this section) that precedes this page. Then, start at the beginning of the tables and work your way through each table to the end of this section until you correct any fault. If a table pertains to equipment(s)/function(s) not present in your subsystem, turn to the following table, etc. until you have worked through all tables provided.

It is possible to have errors in the address or data lines which would affect operation of the entire terminal. The DDLT's which follow are constructed such that a more basic function must operate correctly before a valid check of a supplement function is possible. Thus, the basic processor, RAM/ROM memory, refresh, and +5-V dc regulator portions of the display logic module must operate correctly before being able to check an option such as highlight or printer. In keeping with this philosophy, if an error should occur when running the subsystem diagnostic test mode, each option function card (module) present in the display logic module (figure CRT62) should be removed (procedure CRT8) and re-installed one at a time while re-running test mode each time to verify if that function card introduces the error. This is covered in table TS1, DDLT for Terminal Subsystem.



ARRANGEMENT OF DIAGNOSTIC AND CORRECTIVE MAINTENANCE INFORMATION

Figure 6-2 shows the arrangement of the diagnostic and corrective maintenance information throughout the remainder of this section.

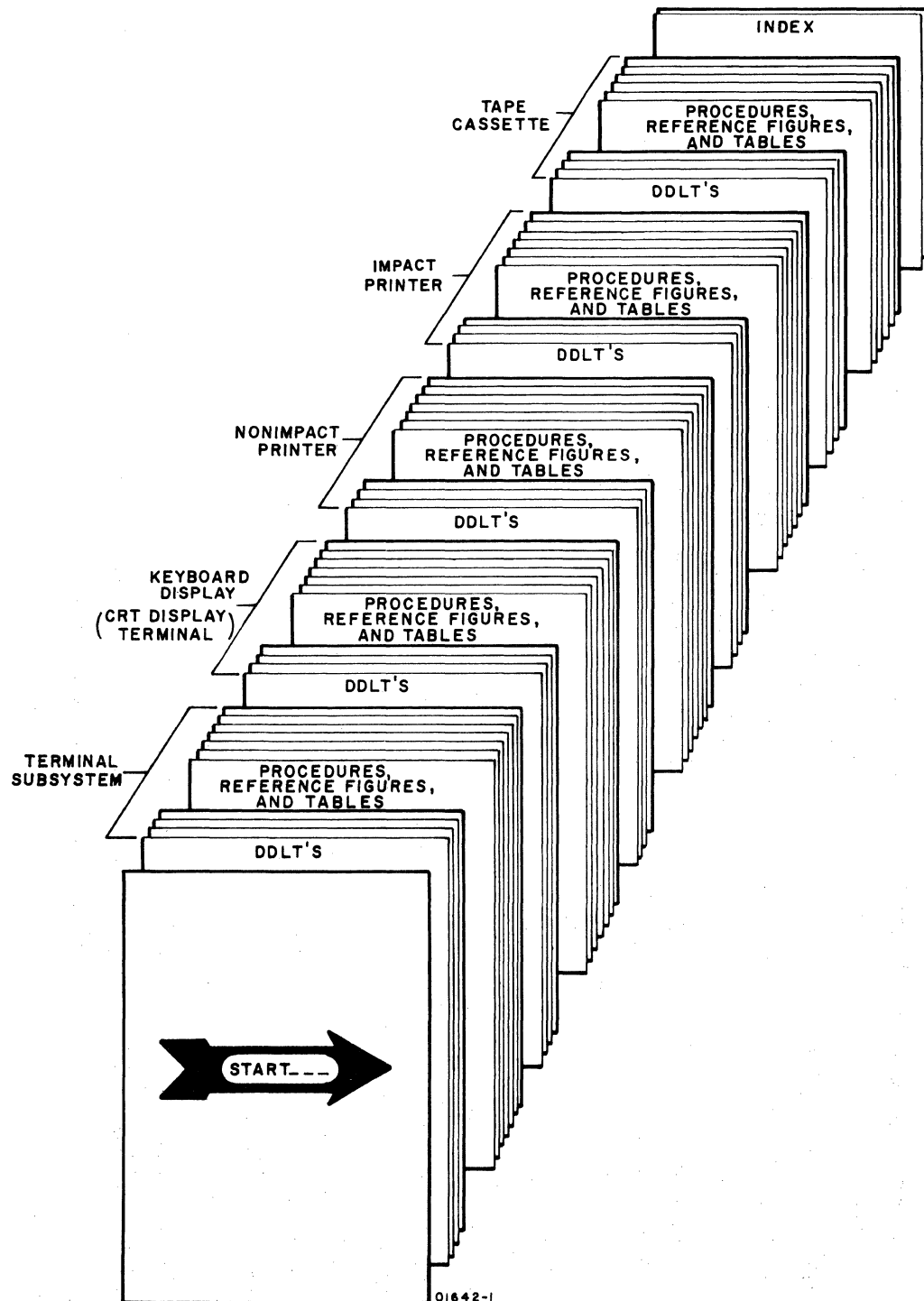
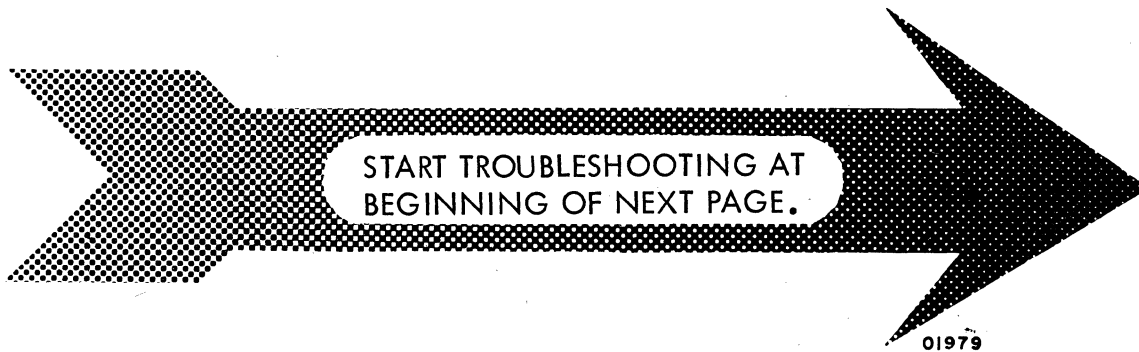

Figure 6-2. Arrangement of Diagnostic and Corrective Maintenance Information

NOTE

If you are unfamiliar with diagnostic decision logic tables, read the explanation of their use described earlier in this section. Then, start at the beginning of the next page and work your way through to the end of this section until you correct any fault.



NOTE

Because the diagnostic decision logic tables (DDL'T's) require much time, money, and effort — you, the user, determine whether they will continue in future manuals as a diagnostic aid.

Please use the comment sheet at the back of this manual to let us know the following: 1) Did you actually use these tables? 2) Do you think they are valuable and why or why not? 3) Do you feel this is the best approach to a "cookbook" troubleshooting manual that you have seen, considering that the DDL'T's tie everything together; that is, diagnostics, procedures, figures, and tables? 4) To you, what is their most serious shortcoming? 5) How would you improve the DDL'T's? Remember, the comment sheet is your direct link with the writer.

TABLE TS1. DDLT FOR TERMINAL SUBSYSTEM



TERMINAL SUBSYSTEM OPERATION CHECKS									
ASSUME									
Subsystem equipment(s) required at the site have been individually installed and checked out (Installation and Checkout, section 3) at a prior time. All ac power cords and signal cables present and secure. If printer present, paper properly loaded (procedure NIP1 or IMP1). If tape cassette unit present, usable tape cassette (with BOT and EOT holes) is loaded ready for read/write. An operational failure occurred during subsystem use and the information available does not point conclusively to a particular part of the subsystem, e.g., keyboard display, printer, or tape cassette unit, as being at fault.									
CONDITIONS	SITUATION								
	1	2	3	4	5	6	7	8	9
Apply subsystem power (procedure TS1). Does each cabinet/equipment present appear to have power?	Y	Y	Y	Y	Y	Y	Y	Y	N
See Test Mode Diagnostic in a prior part of this section, and step through entire test described there. Did Test Mode complete without error?	Y	Y	Y	Y	Y	Y	N	-	
If a tape cassette unit is present, exercise it via the keyboard. Do this per Tape Cassette Unit Checkout procedure in section 3. Did tape unit check out OK?	Y	Y	Y	Y	Y	N	-	-	O T H E R
Place terminal subsystem online with communication subsystem (this may require establishing connection via a site modem; site personnel may be able to assist here). Attempt system communications (sending/receiving per system protocol). Do communications operate as intended for the site application? (site management personnel may assist here)	Y	Y	Y	N	N	-	-	-	
The operational failure which originally occurred does not seem to be recurring. Could the original failure have been operator error or random communication system error? Exercise careful judgement here based on all information available.	Y	N	N	-	-	-	-	-	
Contact communication system maintenance personnel. Did they acknowledge a communications line problem?	-	Y	N	Y	N	-	-	-	
ACTIONS	SEQUENCE								
Turn subsystem over to site operator(s) and observe that it works properly for them. If not, start more detailed analysis at table CRT1 and continue through following DDLTs until fault is found.	X	X	-	X	-	-	-	-	-
Start more detailed analysis at table CRT1 and continue through following DDLTs until fault is found.	-	-	2	-	3	-	-	-	-
Carefully check that operator procedures/uses are compatible with the particular terminal installation (switches, etc.). Instruct operators as necessary or, if system requires, change internal/external switch settings (figure CRT55).	-	-	1	-	1	-	-	-	-
Contact communications main system personnel and check if they have central processor trouble.	-	-	3	-	2	-	-	-	-
Start detailed troubleshooting at table TCU1, DDLT for Tape Cassette Unit.	-	-	-	-	-	X	-	-	-
Start detailed troubleshooting at DDLT for cabinet which did not power up, e.g., table CRT1, table NIP1, table IMP1, or table TCU1.	-	-	-	-	-	-	-	X	-
Remove each supplement function (option) card (module) present in the display logic module (figure CRT62 and procedure CRT8). Rerun test mode. If test mode still has errors, start more detailed analysis at table CRT1 and continue through following DDLTs until fault is found. However, if test mode runs OK, reinstall the option cards just removed one at a time and rerun test mode after each to verify if that card introduces the error. If one causes test mode error, replace it with a new card (procedure CRT8) and check with test mode again. If error persists, start more detailed analysis at table CRT1. If test mode OK, continue going through the module, adding and checking each option function card which you had removed. If, when done, test mode error still occurs, go to table CRT1 and subsequent DDLTs as necessary until problem is solved.	-	-	-	-	-	-	X	-	-
Call next level of support.	-	-	4	-	4	-	-	-	X
Note: After completing any repairs or maintenance, verify that the subsystem is operational by rerunning test mode.									

Procedure TS1 — Turning On Subsystem Power

Before turning on subsystem power, first verify that required subsystem cables are connected. These include the cables identified in Installation, section 3, which are as follows:

- Keyboard cable.
- Display-to-communication system cable, e.g., cable to site data set or to current-loop line.
- Display-to-printer cable (if printer present but tape unit is not).
- Display-to-tape unit cable (if tape unit present).
- Tape unit-to-printer cable (if both tape unit and printer present).

Turn on subsystem power as follows:

At the site modem cabinet:

- 1) If site modem is present (instead of current-loop interface), check that modem ac power cord is connected to site power outlet.

At the printer (as per procedure NIP1 or IMP1):

- 2) If printer is present, check that ac power cord is connected to site power outlet.
- 3) Press power indicator/switch to ON (switch illuminates).
- 4) If impact printer, wait 5 seconds and press START/STOP indicator switch (switch illuminates).

At the tape cassette unit (as per procedure TCU1):

- 5) If cassette unit is present, check that ac power cord is connected to site power outlet.
- 6) Place rear panel, white circuit breaker up (fan starts and some control panel indicators light).

At the keyboard display (as per procedure CRT1):

- 7) Check that keyboard display ac power cord is connected to site power outlet.
- 8) Place rear panel, white circuit breaker up.
- 9) Press POWER ON/OFF switch on operator panel to ON (blinking cursor appears on screen within 30 seconds).

The preceding steps should turn power on at a properly operating subsystem. If trouble occurs in applying power to a cabinet in the subsystem, refer to the DDLT for that cabinet and begin detailed troubleshooting.

Procedure TS2 — Turning Off Subsystem Power

To turn off subsystem power, perform the following:

At the printer (as per procedure NIP2 or IMP2):

- 1) If printer is present, press power indicator/switch (light extinguishes).

At the tape cassette unit (as per procedure TCU2):

- 1) If tape cassette unit is present, toggle rear panel, white circuit breaker down.

At the keyboard display (as per procedure CRT2):

- 1) Press POWER ON/OFF switch on operator panel to OFF.

The preceding steps turn power off for each cabinet which may be present as part of a terminal subsystem. Power must be turned off of any modem which may be present at the site. For removing power from each cabinet, see the individual cabinet power-off procedures referenced in the steps preceding this one for the subsystem.

Procedure TS3 — Removing/Replacing Subsystem Cables

To remove any interconnecting cable within the subsystem from its cabinet connector on either or both ends, proceed as follows:

- 1) Turn power off of subsystem cabinets which cable connects to (see the particular cabinets power off procedures).
- 2) Loosen both retaining screws on each connector to be removed.
- 3) Pull cable connector straight back and off of cabinet mating connector.

Replace any interconnecting cable within the subsystem at its cabinet on either or both ends as follows:

- 1) Verify cable/connector is correct (section 5, Diagrams in volume 1 identify correct cable part numbers).
- 2) Slide cable connector straight on cabinet mating connector.
- 3) Tighten both retaining screws on each connector replaced.
- 4) Reapply desired power to cabinet(s) per appropriate power-on procedures.

Procedure TS4 — Checking Subsystem Cables

To check any interconnecting cables within the subsystem, proceed as follows:

- 1) Refer to procedure TS3 and do steps 1 through 3 to unplug cable connectors from mating cabinet connectors at both ends.
- 2) Carefully inspect connector pins on both ends for possible damage. If damage is found on connector attached to end of cable, discard cable for a new one. If damaged pins are found on mating connector in a cabinet, see remove/replace procedure for that cabinet and replace faulty connector. In either case, after correcting the problem, replace cable (procedure TS3).
- 3) Use information in section 5, Diagrams, to identify particular cable part number. Using the wire list portion of the cable assembly drawing in section 5, Diagrams, do a pin-to-pin continuity check with an ohmmeter or continuity-checking idiot light.
- 4) If an open circuit is found, repair if possible/desired, e.g., solder loose connection at connector or replace broken wire in bundle, or replace faulty cable with a new one (procedure TS3).

Procedure TS5 — Removing/Replacing Subsystem Cabinets

To remove any cabinet present in the subsystem, proceed as follows:

- 1) Turn off subsystem power (procedure TS2).
- 2) For cabinet to be removed, pull ac power cord from site power outlet.
- 3) Remove subsystem cable(s) from cabinet to be removed (procedure TS3).
- 4) Lift cabinet and carry away from its position in the subsystem.

To re-install any cabinet in the subsystem, proceed as follows:

- 1) Refer to section 3, Installation and Checkout, and uncrate, install, and check the particular cabinet per instructions.
- 2) After replaced cabinet checks out, reapply subsystem power as required (procedure TS1).



TABLE CRT1. DDLT FOR DISPLAY TERMINAL (SHEET 1 OF 8)

READ-ONLY MEMORY (ROM) TEST (TEST SECTION 0)											
ASSUME											
Identify normal operating positions for all external/internal switches. Use figure CRT55 for this purpose. Display terminal power cord is connected to ac outlet. Circuit breaker CB1 (rear panel) is up.											
CONDITIONS	SITUATIONS										
	1	2	3	4	5	6	7	8	9	10 11	
Does circuit breaker CB1 remain up?	Y	Y	Y	Y	Y	Y	Y	Y	Y	N	O T H E R
Press POWER ON/OFF switch to OFF position. Place TEST/NORMAL switch (rear panel) in NORMAL position. Place ON LINE/LOCAL switch in LOCAL position. Press POWER ON/OFF switch to ON position. Wait 30 seconds. Does a normal blinking cursor appear on the screen?	Y	Y	Y	Y	Y	Y	N	N	N	-	
Place TEST/NORMAL switch in TEST position. Ready printer and/or tape unit for operation, if available (see operators guide for paper-loading, etc.). Press MASTER CLEAR switch (rear panel). Does checksum display appear as shown in figure CRT56?	Y	Y	N	N	N	N	-	-	-	-	
Is ALERT indicator illuminated?	Y	N	-	-	-	-	-	-	-	-	
Turn up INTENSITY control. Is normal raster visible (figure CRT57)?	-	-	-	-	-	-	Y	N	N	-	
Do any characters appear on screen?	-	-	Y	Y	Y	N	-	-	-	-	
Is anything visible?	-	-	-	-	-	-	-	Y	N	-	
Is a general checksum display format recognizable?	-	-	Y	Y	N	-	-	-	-	-	
Does one or more of checksum digits have nonzero value (alarm sounds)?	-	-	Y	N	-	-	-	-	-	-	
ACTIONS	SEQUENCE										
ROM test ran OK. Go to sheet 2 and run RAM test.	X	-	-	-	-	-	-	-	-	-	
Go to sheet 8 and perform all voltage checks.	-	-	-	-	-	-	-	4	6	1	
Observe printed circuit boards for proper seating.	-	1	1	1	1	1	1	1	1	-	
Perform monitor adjustment and troubleshooting (procedure CRT26). If required, replace monitor board (procedure CRT11).	-	-	-	-	-	-	7	3	7	-	
Replace refresh board 06 (procedure CRT8).	-	-	3	2	4	-	2	2	4	-	
Observe crt cables and connections and crt for lighted filament.	-	-	-	-	-	-	-	5	2	-	
Observe backpanel connections.	-	4	5	5	5	5	5	8	3	-	
Replace crt (procedure CRT13).	-	-	-	-	-	-	-	7	11	-	
Check yoke (procedure CRT14). Replace yoke, if required (procedure CRT15).	-	-	-	-	-	-	-	6	8	-	
Check voltages: +5 V, ±12 V, and -9 V (procedure CRT22).	-	-	6	6	6	4	6	-	5	-	
Replace processor board 09 (procedure CRT8).	-	3	4	4	2	3	4	-	-	-	
Replace ROM/RAM board 08 (procedure CRT8). If same error recurs, replace Extended Memory board 05B (procedure CRT8).	-	2	2	3	3	2	3	-	-	-	
Replace indicator-panel LED board (procedure CRT10).	-	5	-	-	-	-	-	-	-	-	
Check TEST/NORMAL and MASTER CLEAR switches and replace if necessary (procedure CRT6 and CRT7).	-	-	-	-	7	6	-	-	-	-	
Replace high-voltage transformer (procedure CRT3).	-	-	-	-	-	-	-	-	9	-	
Check INTENSITY control and related cabling (procedure CRT23).	-	-	-	-	-	-	-	-	10	-	
Check POWER ON/OFF switch (procedure CRT28).	-	-	-	-	-	-	-	-	12	2	
Replace +5 V Regulator board 03A (procedure CRT8).	-	-	-	-	-	-	-	-	-	3	
Replace bulk power supply (procedure CRT17).	-	-	-	-	-	-	-	-	-	4	
Call next level of support.	-	-	-	-	-	-	-	-	-	X	
Note: After completing any repairs or maintenance, verify that the subsystem is fully operational by rerunning test mode.											

TABLE CRT1. DDLT FOR DISPLAY TERMINAL (SHEET 2 OF 8)

RANDOM ACCESS MEMORY (RAM) TEST (TEST SECTION 1)							
ASSUME							
ROM Test (Test Section 0) ran OK. Press 9 key.							
CONDITIONS	SITUATIONS						
	1	2	3	4	5	6	7
Does ALERT light blink off? (it must blink off to indicate start of RAM test).	Y	Y	Y	Y	Y	N	O T H E R
Does display cycle through full screen of all 128 displayable characters twice without halting? (Second pass displays blinking underline under alternate character positions.)	Y	N	N	N	N	-	
Did test halt before two complete passes? Passes should continue.	-	Y	Y	N	N	-	
Did alarm sound?	-	Y	N	-	-	-	
Is checksum display from ROM Test (Test Section 0) still being displayed?	-	-	-	Y	N	-	
ACTIONS	SEQUENCE						
RAM Test ran OK. Go to sheet 3 and run Shifting Pattern and I/O Test (Test Section 2).	X	-	-	-	-	-	
Observe for proper printed circuit board seating.	-	1	1	2	1	1	-
Replace ROM/RAM board 08 (procedure CRT8). If same error recurs, replace Extended Memory board 05B (procedure CRT8).	-	2	2	-	2	-	-
Replace processor board 09 (procedure CRT8).	-	5	3	-	3	2	-
Check voltages: +5 V, ±12 V, and -9 V (procedure CRT22).	-	3	4	-	4	-	-
Observe backpanel connections.	-	4	5	4	5	4	-
Check keyboard cable and connector.	-	-	-	1	-	3	-
Replace keyboard printed circuit board (procedure CRT18).	-	-	-	3	-	5	-
Call next level of support.	-	-	-	-	-	-	X
Note: After completing any repairs or maintenance, verify that the subsystem is fully operational by rerunning test mode.							

62962300 C

6B-91

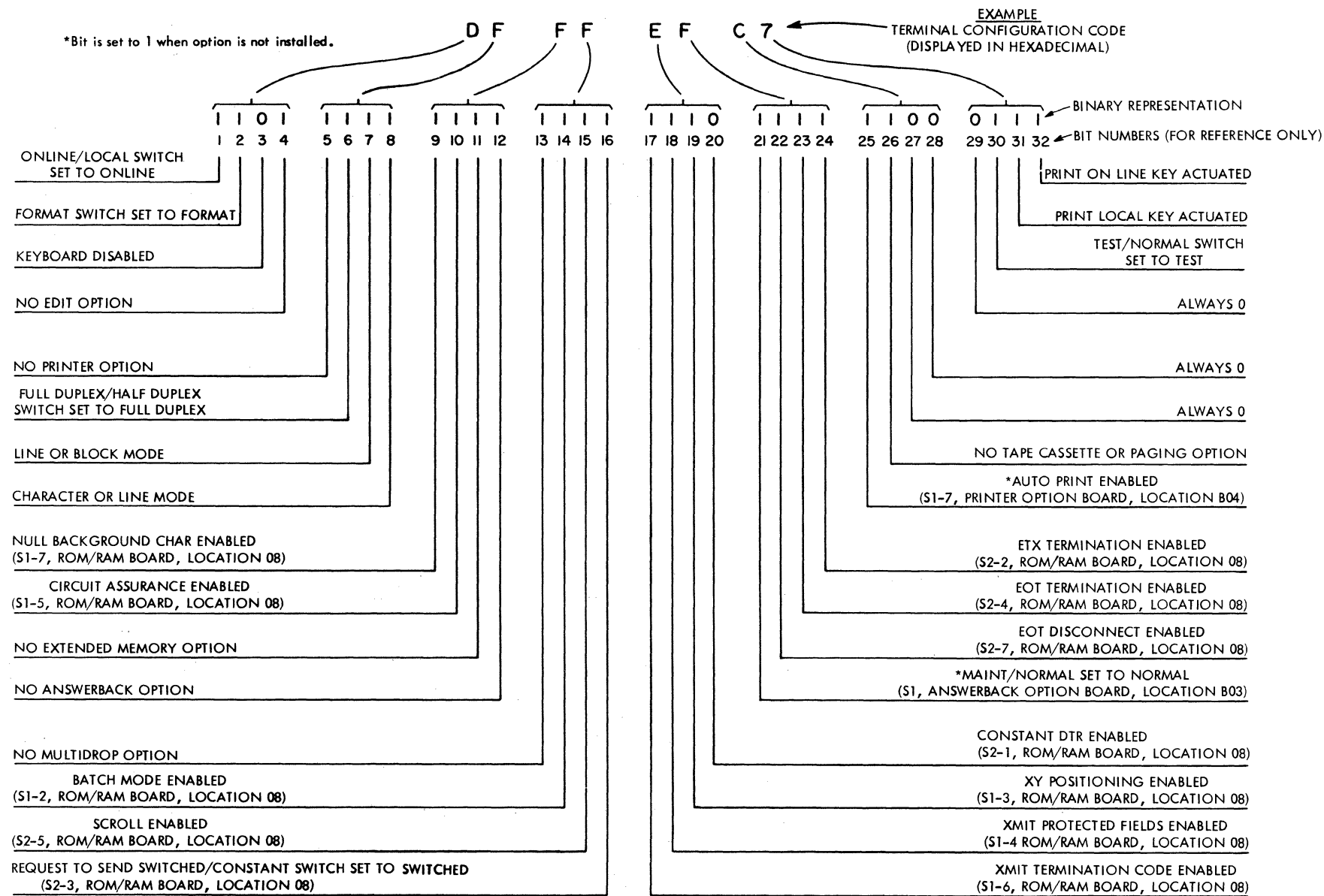
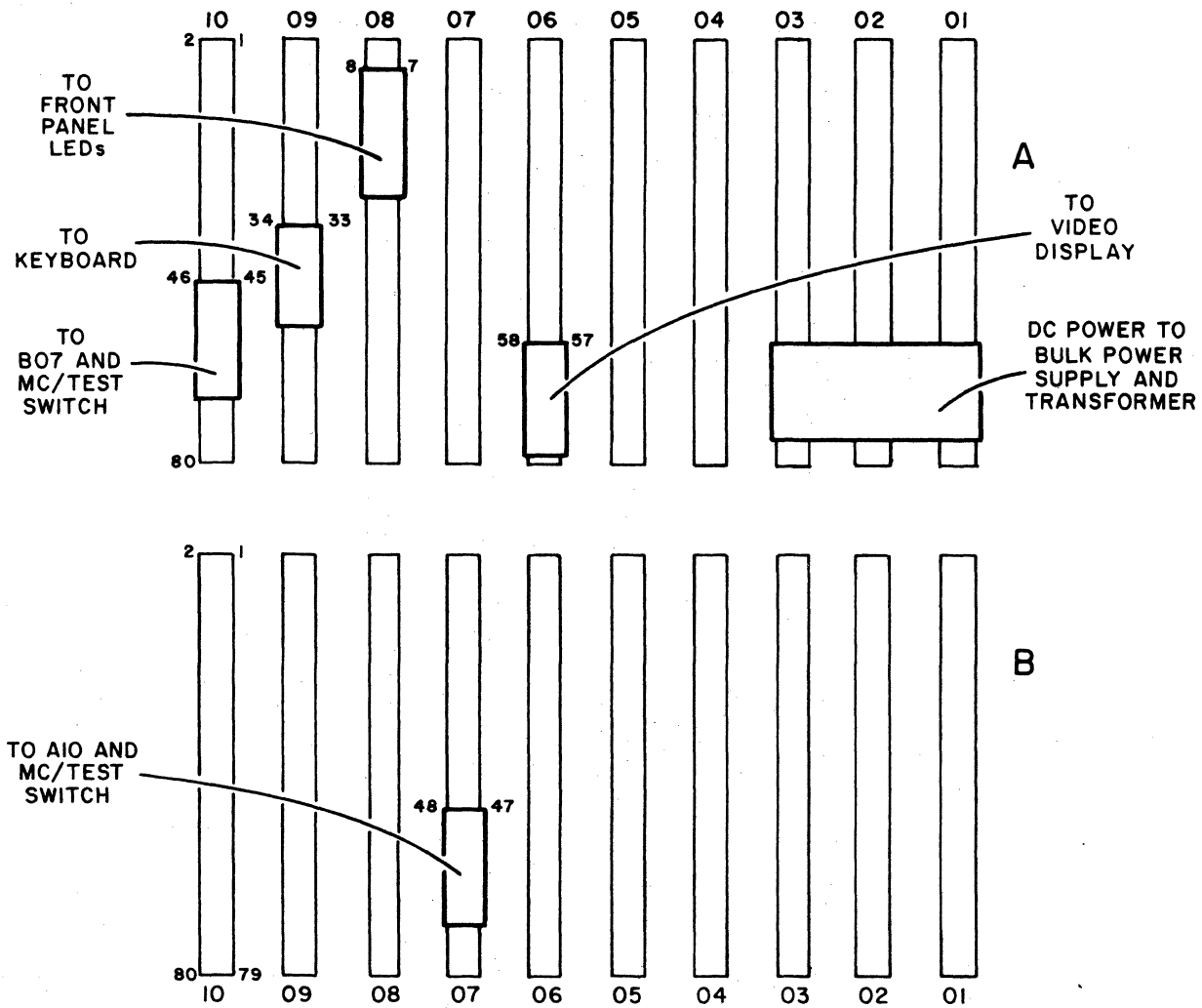

Figure CRT58. Terminal Configuration Display Bit Assignments

01973



01975

Figure CRT59. Back Panel Cabling of Logic Module

TABLE CRT1. DDLT FOR DISPLAY TERMINAL (SHEET 3 OF 8)

SHIFTING PATTERN AND I/O TEST (TEST SECTION 2)							
ASSUME							
RAM Test (Test Section 1) ran OK. Press 9 key.							
CONDITIONS	SITUATIONS						
	1	2	3	4	5	6	7
Is continuously shifting pattern of characters displayed on screen?	Y	Y	Y	N	N	N	O T H E R
Did test halt?	-	-	-	Y	Y	N	
Did alarm sound?	-	-	-	Y	N	N	
Are DATA REC and DATA TRANS indicators lit and do they blink occasionally?	Y	Y	N	-	-	-	
Toggle HIGH RATE/300/LOW RATE baud switch through all three positions while observing shifting pattern on screen. Did rate of shifting pattern speed up/slow down per baud rate switch settings as expected?	Y	N	-	-	-	-	
ACTIONS	SEQUENCE						
Shifting Pattern and I/O Test ran OK. Go to sheet 4 and run Keyboard and Display Quality Checks.	X	-	-	-	-	-	-
Observe for proper printed circuit board seating.	-	1	1	1	1	1	-
Replace ROM/RAM board 08 (procedure CRT8). If same error recurs, replace Extended Memory board 05B (procedure CRT8).	-	-	-	6	3	2	-
Replace processor board 09 (procedure CRT8).	-	2	3	2	2	3	-
Check voltages: +5 V, ±12 V, and -9 V (procedure CRT22).	-	-	-	3	4	4	-
Observe backpanel connections.	-	-	2	4	5	5	-
Check loop-back contacts and wiring of TEST/NORMAL switch and replace if necessary (procedure CRT6).	-	-	-	5	6	-	-
Replace LED board for indicator/switch panel (procedure CRT10).	-	-	4	-	-	-	-
Check Baud Rate switches and related wiring (procedure CRT24).	-	3	-	-	-	-	-
Call next level of support.	-	-	-	-	-	-	X
Note: After completing any repairs or maintenance, verify that the subsystem is fully operational by rerunning test mode.							

TABLE CRT1. DDLT FOR DISPLAY TERMINAL (SHEET 4 OF 8)

KEYBOARD AND DISPLAY QUALITY CHECKS (TEST SECTION 3)												
ASSUME												
Shifting Pattern and I/O Test (Test Section 2) ran OK. Press 9 key.												
CONDITIONS	SITUATIONS											
	1	2	3	4	5	6	7	8	9	10	11	
Does shifting pattern of previous test halt at end of present screen shift?	Y	Y	Y	Y	Y	Y	Y	Y	Y	N		
Remove hood (procedure CRT21). Perform keyboard checks (procedure CRT25). Was proper character displayed for each keyboard entry?	Y	Y	Y	Y	Y	Y	Y	Y	N	-		
Place 64/96 Character switch in 96 position. Press lowercase "m" key. Are "m's" clear and well defined over entire screen	Y	Y	Y	Y	Y	Y	Y	N	-	-	O T H E R	
Press uppercase "H" key. Are all "H's" same height and width?	Y	Y	Y	Y	Y	Y	-	-	-	-		
Are "H's" stable?	Y	Y	Y	Y	Y	N	-	-	-	-		
Press space bar once. Turn INTENSITY control until raster appears. Is crt phosphor free of any objectionable burn spots or blemishes?	Y	Y	Y	Y	N	-	-	-	-	-		
Are all four sides of raster rectangle straight?	Y	Y	Y	N	-	-	-	-	-	-		
Are height and width of display approximately 5.25 in. (13.3 cm) and 8 in. (20.3 cm), respectively?	Y	Y	N	-	-	-	-	-	-	-		
Is printer present and do you wish to check it now?	Y	N	-	-	-	-	-	-	-	-		
ACTIONS	SEQUENCE											
Keyboard and Display Quality Checks are OK. Return INTENSITY control to normal. Go to appropriate DDLT (NIP1 or MIP1) and run printer checks.	X	-	-	-	-	-	-	-	-	-		-
Keyboard and Display Quality Checks are OK. Return INTENSITY control to normal. Press space bar twice. Go to sheet 5 and run External Switch Checks.	-	X	-	-	-	-	-	-	-	-		
Observe printed circuit boards for proper seating.	-	-	-	-	-	-	-	-	4	1	-	
Replace ROM/RAM board 08 (procedure CRT8). If same error recurs, replace Extended Memory board 05B (procedure CRT8).	-	-	-	-	-	-	-	-	-	2	-	
Replace processor board 09 (procedure CRT8).	-	-	-	-	-	-	-	-	-	5	3	
Check voltages: +5 V, ±12 V, and -9 V (procedure CRT22).	-	-	-	-	-	-	-	-	-	4	-	
Observe backpanel connections.	-	-	-	-	-	-	-	-	-	2	5	
Check keyboard cable and connector.	-	-	-	-	-	-	-	-	-	1	-	
Replace keyboard printed circuit board (procedure CRT18).	-	-	-	-	-	-	-	-	-	7	-	
Replace refresh board 06 (procedure CRT8).	-	-	-	-	-	-	-	-	-	6	-	
Check 64 CHAR/96 CHAR switch (procedure CRT28).	-	-	-	-	-	-	-	-	-	3	-	
Perform monitor adjustment and troubleshooting (procedure CRT26).	-	-	-	-	-	-	X	X	-	-	-	
Perform monitor adjustment and troubleshooting (procedures CRT26 and CRT30).	-	-	-	-	-	X	-	-	-	-	-	
Replace crt (procedure CRT13) if spot interferes with character display.	-	-	-	X	-	-	-	-	-	-	-	
Perform monitor adjustment and troubleshooting (procedure CRT14).	-	-	X	-	-	-	-	-	-	-	-	
Perform monitor adjustment and troubleshooting (procedure CRT26, steps 8 and 9).	-	-	X	-	-	-	-	-	-	-	-	
Call next level of support.	-	-	-	-	-	-	-	-	-	-	X	
Note: After completing any repairs or maintenance, verify that the subsystem is fully operational by rerunning test mode.												

TABLE CRT1. DDLT FOR DISPLAY TERMINAL (SHEET 5 OF 8)

EXTERNAL SWITCH CHECKS (TEST SECTION 7)							
ASSUME							
Previous test sections ran OK.							
CONDITIONS	SITUATIONS						
	1	2	3	4	5	6	7
Is terminal configuration code displayed on screen (figure CRT58). Note: Display shown in referenced figure is an example only and is not necessarily the display that appears.	Y	Y	Y	Y	Y	N	O T H E R
Place CHARACTER/LINE/BLOCK switch in each of its positions while observing bits 7 and 8 of display, i.e., bits 7 and 8 as identified in figure CRT58. Did bits 7 and 8 set or clear as defined in figure CRT58?	Y	Y	Y	Y	N	-	
Place ON LINE/LOCAL switch to ON LINE and then to LOCAL while observing bit 1 of display. Was bit 1 set when switch was in ON LINE position and cleared in LOCAL?	Y	Y	Y	N	-	-	
Place FULL DUPLEX/HALF DUPLEX switch to FULL DUPLEX and then to HALF DUPLEX while observing bit 6 of display. Was bit 6 set when switch was in FULL DUPLEX position and cleared in HALF DUPLEX?	Y	Y	N	-	-	-	
Place FORMAT switch in FORMAT position and then to its alternate position while observing bit 2 of display. Was bit 2 set when switch was in FORMAT position and cleared in alternate position?	Y	N	-	-	-	-	
ACTIONS							
SEQUENCE							
External Switch Checks are OK. Go to sheet 6 and perform Internal Switch and Option Installation Checks.	X	-	-	-	-	-	-
Observe for proper printed circuit board seating.	-	2	2	2	2	1	-
Replace ROM/RAM board 08 (procedure CRT8). If same error recurs, replace Extended Memory board 05B (procedure CRT8).	-	4	4	4	4	2	-
Replace processor board 09 (procedure CRT8).	-	-	-	-	5	3	-
Check voltages: +5 V, ±12 V, and -9 V (procedure CRT22).	-	-	-	-	-	4	-
Observe backpanel connections.	-	3	3	3	3	5	-
Check CHARACTER/LINE/BLOCK switch and wiring (procedure CRT27).	-	-	-	-	1	-	-
Check ON LINE/LOCAL switch and wiring (procedure CRT28).	-	-	-	1	-	-	-
Check FULL DUPLEX/HALF DUPLEX switch and wiring (procedure CRT28).	-	-	1	-	-	-	-
Check FORMAT switch and wiring (procedure CRT28).	-	1	-	-	-	-	-
Call next level of support.	-	-	-	-	-	-	X
Note: After completing any repairs or maintenance, verify that the subsystem is fully operational by rerunning test mode.							

TABLE CRT1. DDLT FOR DISPLAY TERMINAL (SHEET 6 OF 8)

INTERNAL SWITCH AND OPTION INSTALLATION CHECKS								
ASSUME								
External Switch Checks were OK.								
CONDITIONS	SITUATIONS							
	1	2	3	4	5	6	7	8
Remove hood (procedure CRT21). Perform internal switch checks by pressing switches (figure CRT55). Did switches toggle bits as shown in figure CRT58?	Y	Y	Y	Y	Y	Y	N	O T H E R
Examine installed-option bits shown in figure CRT63. Are appropriate bits cleared for installed options (figure CRT58).	Y	Y	Y	Y	Y	N	-	
Are appropriate bits set for options not installed.	Y	Y	Y	Y	N	-	-	
Press PRINT ON LINE key while observing bit 32. Is bit 32 set?	Y	Y	Y	N	-	-	-	
Press PRINT LOCAL key while observing bit 31. Is bit 31 set?	Y	Y	N	-	-	-	-	
Slide TEST/NORMAL switch to NORMAL position while observing bit 30. Is bit 30 cleared?	Y	N	-	-	-	-	-	
ACTIONS	SEQUENCE							
Test Mode ran OK. Return all switches to their normal operating position (see decals inside crt display for internal switch settings or refer to table used to identify settings earlier).	X	-	-	-	-	-	-	-
Observe printed circuit boards for proper seating.	-	4	3	3	1	1	1	-
Replace printed circuit board containing faulty switch (procedure CRT8).	-	-	-	-	-	-	2	-
Replace ROM/RAM board 08 (procedure CRT8). If same error recurs, replace Extended Memory board 05B (procedure CRT8).	-	5	5	5	2	3	3	-
Observe backpanel connections.	-	3	2	2	3	4	-	-
Check keyboard cable and connectors.	-	-	1	1	-	-	-	-
Replace appropriate option board (see figure CRT62 for locations).	-	-	-	-	-	2	-	-
Replace keyboard printed circuit board (procedure CRT18).	-	-	4	4	-	-	-	-
Check TEST/NORMAL switch and related wiring and replace if necessary (procedure CRT6).	-	2	-	-	-	-	-	-
Check for positive positioning of TEST/NORMAL switch and for intermittent operation of switch.	-	1	-	-	-	-	-	-
Call next level of support.	-	-	-	-	-	-	-	X
Note: After completing any repairs or maintenance, verify that the subsystem is fully operational by rerunning test mode.								

TABLE CRT1. DDLT FOR DISPLAY TERMINAL (SHEET 7 OF 8)

MISCELLANEOUS CHECKS											
ASSUME											
Test Mode ran OK. All switches, including TEST/NORMAL switch, are returned to their normal operating positions.											
CONDITIONS	SITUATIONS										
	1	2	3	4	5	6	7	8	9	10	11
Disable Batch Mode by placing side of rocker switch nearest BATCH MODE label on printed circuit board up. Place CHARACTER/LINE/BLOCK switch in LINE position. Place FORMAT switch in unlabeled position. Press MASTER CLEAR switch. Press following keys several times each in sequence: →, ↑, ←, ↓ Did cursor move in direction indicated?	Y	Y	Y	Y	Y	Y	Y	Y	Y	N	
While pressing and holding REPEAT key, press one or more alphanumeric keys in succession, filling at least 1-1/2 lines, ending in center of line. Did keys repeat?	Y	Y	Y	Y	Y	Y	Y	Y	N	-	O T H E R
Did audible alarm sound near end of first line?	Y	Y	Y	Y	Y	Y	Y	N	-	-	
Press CARRIAGE RETURN key. Did cursor move to left of screen on same line?	Y	Y	Y	Y	Y	Y	N	-	-	-	
Press LINE CLEAR key. Is only line directly above cursor cleared?	Y	Y	Y	Y	Y	N	-	-	-	-	
Press CLEAR key. Is entire display cleared?	Y	Y	Y	Y	N	-	-	-	-	-	
Fill at least one line near center of screen with characters. Place CHARACTER/LINE/BLOCK switch in CHARACTER position. Press LINE FEED. Did cursor move down one line without moving horizontally?	Y	Y	Y	N	-	-	-	-	-	-	
Place CHARACTER/LINE/BLOCK switch in LINE position. Press RESET key. Did cursor move to lower, left corner of display?	Y	Y	N	-	-	-	-	-	-	-	
With SCROLL switch disabled (figure CRT55), place CHARACTER/LINE/BLOCK switch in BLOCK position. Press RESET key. Did cursor move to upper, left corner of display?	Y	N	-	-	-	-	-	-	-	-	
ACTIONS	SEQUENCE										
Miscellaneous checks are OK. Return all switches to normal operating positions.	X	-	-	-	-	-	-	-	-	-	-
Recheck positions of switches, including TEST/NORMAL switch.	-	1	1	1	-	-	-	-	-	1	-
Observe printed circuit boards for proper seating.	-	4	4	4	2	2	2	1	3	3	-
Check keyboard cable and connectors.	-	6	6	6	1	1	1	-	1	2	-
Replace keyboard printed circuit board (procedure CRT18).	-	7	7	7	3	3	3	-	2	4	-
Replace ROM/RAM board 08 (procedure CRT8). If same error recurs, replace Extended Memory board 05B (procedure CRT8).	-	2	2	2	5	5	5	2	4	5	-
Replace processor board 09 (procedure CRT8).	-	5	5	5	6	6	6	5	5	6	-
Observe backpanel connections.	-	3	3	3	4	4	4	4	6	7	-
Check audible alarm and cabling (procedure CRT29).	-	-	-	-	-	-	-	3	-	-	-
Call next level of support.	-	-	-	-	-	-	-	-	-	-	X
Note: After completing any repairs or maintenance, verify that the subsystem is fully operational by rerunning test mode.											

TABLE CRT1. DDLT FOR DISPLAY TERMINAL (SHEET 8 OF 8)

VOLTAGE CHECKS							
ASSUME							
Perform voltage checks (procedure CRT20).							
CONDITIONS	SITUATIONS						
	1	2	3	4	5	6	7
Were all voltage checks OK, steps 1 through 14?	Y	Y	Y	N	N	N	O
Were +15 and +5-V checks OK, steps 15 through 23?	Y	Y	Y	N	N	N	T
Are LEDs illuminated on +5-V regulator board 03 (figure CRT33)?	Y	Y	Y	Y	N	N	H
Are LEDs illuminated on bulk power supply printed circuit board (figure CRT39)?	Y	Y	Y	Y	Y	N	E
Is raster displayed on crt?	Y	N	-	-	-	-	R
ACTIONS	SEQUENCE						
Voltage check OK. Proceed to DDLT for next function/equipment present in system.	X	-	-	-	-	-	-
Replace high-voltage transformer (procedure CRT3).	-	X	-	-	-	-	-
Replace video printed circuit board (procedure CRT11).	-	-	X	-	-	-	-
If fuse F1 on +15-V regulator has blown, replace fuse (figure CRT4). Check for +19-V dc on base of +15-V regulator power transistor (figure CRT4). Check for +15-V dc on emitter of +15-V regulator power transistor (figure CRT4). If +19 ± 2 V is found on base of transistor, but +15 ± 2 V is not found on emitter, replace power transistor (procedure CRT4); if voltages are OK, replace printed circuit board.	-	-	-	X	-	-	-
Replace +5-V regulator board 03 (procedure CRT8).	-	-	-	-	X	-	-
Check for 110-V ac to 124-V ac at wall outlet.	-	-	-	-	-	1	-
Check input power cabling from ac wall outlet to bulk power supply.	-	-	-	-	-	2	-
Replace bulk power supply (procedure CRT17).	-	-	-	-	-	3	-
Call next level of support.	-	-	-	-	-	-	X
Note: After completing any repairs or maintenance, verify that the subsystem is fully operational by rerunning test mode.							

TABLE CRT2. DDLT FOR EXPANDED MEMORY FUNCTION IN DISPLAY TERMINAL

EXPANDED MEMORY OPERATION CHECKS					
ASSUME					
Expanded memory board is in place (05B) in logic rack. Test Section 0 of table CRT1 ran OK.					
CONDITIONS	SITUATIONS				
	1	2	3	4	5
Does Test Section 1 of table CRT1 run by displaying 24 lines of 80 characters each?	Y	Y	Y	N	O
Does Test Section 2 of table CRT1 run by displaying 24 lines of 80 characters each?	Y	Y	N	-	T
Does terminal configuration code, as displayed by Test Section 7, indicate extended memory present (see figure CRT58)?	Y	N	-	-	H
					E
					R
ACTIONS	SEQUENCE				
Extended memory checks OK. Proceed to DDLT for next function/equipment present in system.	X	-	-	-	-
Observe for proper printed circuit board seating.	-	1	1	1	-
Replace Extended Memory board 05B (procedure CRT8). If same error recurs, replace ROM/RAM board 08 (procedure CRT8).	-	2	2	2	-
Replace processor board 09 (procedure CRT8).	-	3	3	3	-
Check +5 V, ±12 V, and -9 V (procedure CRT22).	-	4	4	4	-
Observe backpanel connections.	-	5	5	5	-
Call next level of support.	-	6	6	6	X
Note: After completing any repairs or maintenance, verify that the subsystem is fully operational by rerunning test mode.					

TABLE CRT3. DDLT FOR HIGHLIGHT FUNCTION IN DISPLAY TERMINAL

HIGHLIGHT OPERATION CHECKS			
ASSUME			
Highlight board is in place (05A) in logic rack. Test Sections 0 through 3 of table CRT1 completed OK with highlight in place. All switches, including TEST/NORMAL switch, are returned to their normal operating positions.			
CONDITIONS	SITUATIONS		
	1	2	3
Press MASTER CLEAR switch. Type in 3 or 4 lines of any characters at top of screen and also fill bottom line with characters. Using cursor control keys to position cursor, refer to terminal subsystem operator's guide and check operation of the three functions generated by the Highlighting Control Keys (SHIFT + TAB SET or CONTROL + N, TAB SET or CONTROL + letter O, and CONTROL + W). Check for: 1) begin reduced intensity and end blink, 2) end reduced intensity and/or blink, and 3) begin blink field if not in reduced intensity field. Do these keys produce highlighted display as described in the operator's guide.	Y	N	O T H E R
ACTIONS	SEQUENCE		
Highlight operation checks OK. Proceed to DDLT for next function/equipment present is subsystem.	X	-	-
Observe for proper printed circuit board seating.	-	1	-
Replace highlight board 05A (procedure CRT8).	-	2	-
Replace ROM/RAM board 08 (procedure CRT8). If same error recurs, replace Extended Memory board 05B (procedure CRT8).	-	3	-
Replace processor board 09 (procedure CRT8).	-	4	-
Observe backpanel connections.	-	5	-
Call next level of support.	-	6	-
Note: After completing any repairs or maintenance, verify that the subsystem is operational by rerunning test mode.			

TABLE CRT4. DDLT FOR EDIT FUNCTION IN DISPLAY TERMINAL

EDIT OPERATION CHECKS				
ASSUME				
Extended Memory board is in place (05B) in logic rack. Highlight board is in place (05B) in logic rack. Edit ROM board is in place (01B) in logic rack. Edit search board is in place (02B) in logic rack. Checks of table CRT2, DDLT for Extended Memory Function in Display Terminal completed OK. FORMAT switch is not at FORMAT position. Checks of table CRT3, DDLT for Highlight Function in Display Terminal completed OK.				
CONDITIONS	SITUATIONS			
	1	2	3	4
Press MASTER CLEAR switch. Type in 3 or 4 lines of any characters at top of screen and fill bottom line with characters. Using cursor control keys to position cursor, refer to terminal subsystem operator's guide and check operation of the three type of functions generated by the Edit Control Keys (INSERT, DELETE, TAB SET/TAB). Check for: 1) insert character and line, 2) delete character and line, and 3) forward/backward tabbing. Do these keys produce display editing functions as described in the operator's guide?	Y	Y	N	O T
Press MASTER CLEAR switch. Type in 3 or 4 lines of any characters at top of screen and fill bottom line with characters. Refer again to CRT3, DDLT for Highlight Function in Display Terminal and set up fields highlighted by reduced intensity and blink. Press FORMAT switch to FORMAT position on front panel. Attempt all edit functions in the highlighted fields. Are all highlighted fields protected from entry while FORMAT switch is activating format mode?	Y	N	-	H E R
ACTIONS	SEQUENCE			
Edit operation checks OK. Proceed to DDLT function/equipment present in the subsystem.	X	-	-	-
Observe for proper printed circuit board seating.	-	1	1	-
Replace edit search board 02B (procedure CRT8).	-	2	3	-
Replace edit ROM board 01B (procedure CRT8).	-	3	2	-
Replace processor board 09 (procedure CRT8).	-	4	4	-
Observe backpanel connections.	-	5	5	-
Check two-position FORMAT switch (procedure CRT28).	-	6	6	-
Call next level of support.	-	7	7	X
Note: After completing any repairs or maintenance, verify that the subsystem is operational by rerunning test mode.				

TABLE CRT5. DDLT FOR ANSWERBACK FUNCTION IN DISPLAY TERMINAL

ANSWERBACK OPERATION CHECKS			
ASSUME			
Answerback board is in place (03B) in logic rack with desired ID code sequence installed (procedure CRT31). Test Sections 0 through 2 of table CRT1 completed OK with answerback in place. All switches, including TEST/NORMAL switch, are returned to normal operating positions.			
CONDITIONS	SITUATIONS		
	1	2	3
Press MASTER CLEAR switch. Toggle Maintenance switch on answerback board to ON (figure CRT 63). Press HERE IS key. Does installed ID code sequence appear on display?	Y	N	O T H E R
ACTIONS	SEQUENCE		
Answerback operation checks OK. Toggle answerback Maintenance switch to OFF and proceed to DDLT for next function/equipment in subsystem.	X	-	-
Remove answerback board 03B (procedure CRT8), recheck code-setting diode positions (procedure CRT31), and reinsert board in logic rack in position 03B.	-	2	-
Replace answerback board 03B (procedure CRT8) with a new board which has desired ID code setting (procedure CRT31) and Maintenance switch toggled ON.	-	3	-
Observe for proper printed circuit board seating.	-	1	-
Observe backpanel connections.	-	4	-
Call next level of support.	-	5	-
Note: After completing any repairs or maintenance, verify that the subsystem is operational by rerunning test mode.			

TABLE CRT6. DDLT FOR MULTIDROP FUNCTION IN DISPLAY TERMINAL

MULTIDROP OPERATION CHECKS					
ASSUME					
Multidrop board is in place (03B) in logic rack with desired station configuration and station identifier codes (SCC and SIC) set in the common-use SCC/SIC switches (figure CRT55). Parity, 64/96 character, baud rate, circuit assurance, and background character switches (figure CRT55) each set as communications system requires. EOT disconnect, ETX termination, batch mode, scroll, and autoprint switches (figure CRT55) each toggled to disable position. EOT termination, transfer termination code, and constant DTR switches (figure CRT55) each set to enable position. All external switch settings conform to communications system requirements e.g., HALF DUPLEX, BLOCK, ON LINE, etc. Test Sections 0 through 2 of table CRT1 complete OK with multidrop in place. Test Section 7 of table CRT1 (skip through from Test Section 2 to 7 without doing the checks of 3, 4, and 6) displays the configuration code (figure CRT58) which matches the above switch settings.					
CONDITIONS	SITUATIONS				
	1	2	3	4	5
Using the communication system protocol/procedures, call in to system and request the various possible multidrop operations, one at a time (consult site management personnel for help here). Did each operation perform properly?	Y	Y	Y	N	O T
When calling in from the terminal, do all three TRANSMISSION MODE indicators on front panel light (indicating call in made)?	Y	Y	N	-	H E
When terminal should be receiving polling from the communication system, do CO, REC DATA, and TRANS DATA indicators on front panel light?	Y	N	-	-	R
ACTIONS	SEQUENCE				
Multidrop operation checks OK. Proceed to DDLT for next function/equipment in subsystem.	X	-	-	-	-
Observe for proper printed circuit board seating.	-	1	1	1	-
Observe backpanel connections.	-	3	3	3	-
Replace processor board 09 (procedure CRT8).	-	4	5	5	-
Replace LED board for indicator/switch panel (procedure CRT10).	-	7	8	-	-
Replace multidrop board 03B (procedure CRT8) with new multidrop board with SCC/SIC switches (figure CRT 55) per system protocol.	-	-	4	4	-
Check/establish data set connection with system and observe data set cables for secure connections.	-	2	2	2	-
Call central communications site on a separate line using a standard telephone and ask for the operational status of the system. Also ask if they can send/request any messages to/from your terminal which may identify if the trouble is on the lines, at the central site, or is in fact at your terminal location.	-	6	6	7	-
Replace ROM/RAM board 08 (procedure CRT8). If same error recurs, replace Extended Memory board 05B (procedure CRT8).	-	5	7	6	-
Call next level of support.	-	8	9	8	X
Note: After completing any repairs or maintenance, verify that the subsystem is operational by rerunning test mode.					

TABLE CRT7. DDLT FOR CURRENT LOOP FUNCTION IN DISPLAY TERMINAL

CURRENT LOOP OPERATION CHECKS					
ASSUME					
<p>Current Loop board is in place (10) in logic rack with desired line-adaptor switch settings (figure CRT 55). Parity, 64/96 character, baud rate, background character, ETX termination, EOT termination, transfer termination code, X-Y positioning, scroll, and transmit protected field switches (figure CRT55) each set as communications system requires. EOT disconnect and communications circuit assurance switches (figure CRT55) each toggled to disable position. Request to send switch (figure CRT55) set to constantly enabled position. All external switch settings conform to communications system requirements, e.g., HALF DUPLEX/FULL DUPLEX, BLOCK, ON LINE, etc. Test Sections 0 through 2 of table CRT1 (sheets 1 through 3) OK with current loop in place. Test Section 7 of table CRT1 (sheet 5, skipped to from Test Section 2 without doing the checks of 3, 4, and 6) displays the configuration code (figure CRT58) which matches the above switch settings.</p>					
CONDITIONS	SITUATIONS				
	1	2	3	4	5
Using the communication system protocol/procedures, call into the system and request a message be sent to your terminal. Did this operation perform properly?	Y	Y	Y	N	O T H E R
When sending in from the terminal, do RTS and CTS light simultaneously and does TRANS flicker? (for a short message at HIGH RATE, TRANS may appear to glow steady).	Y	Y	N	-	
When receiving from the communication system, do DTR and CO light and does REC flicker? (for a short message at HIGH RATE, REC may appear to glow steady).	Y	N	-	-	
ACTIONS	SEQUENCE				
Current loop operation checks OK. Proceed to DDLT for next function/equipment in subsystem.	X	-	-	-	-
Observe for proper printed circuit board seating.	-	1	1	1	-
Observe backpanel connections.	-	3	2	4	-
Check current-loop cables for secure connections and verify dc power (10 to 20-V dc range) present on current-loop lines.	-	2	-	2	-
Replace current-loop board 10 (procedure CRT8) with new current-loop board with line-adaptor switches (figure CRT55) set to match particular current-loop line.	-	-	-	3	-
Replace processor board 09 (procedure CRT8).	-	4	3	5	-
Replace LED board for indicator/switch panel (procedure CRT10).	-	5	4	-	-
Call central communications site on a separate line using a standard telephone and ask for the operational status of the system. Also ask if they can send/request any messages to/from your terminal which may identify if the trouble is on the lines, at the central site, or is in fact at your terminal location.	-	-	-	7	-
Replace ROM/RAM board 08 (procedure CRT8). If same error recurs, replace Extended Memory board 05B (procedure CRT8).	-	-	-	6	-
Call next level of support.	-	6	5	8	X
<p>Note: After completing any repairs or maintenance, verify that the subsystem is operational by rerunning test mode.</p>					

TABLE CRT8. DDLT FOR PRINTER INTERFACE CONTROL FUNCTION IN DISPLAY TERMINAL

PRINTER INTERFACE CONTROL OPERATION CHECKS					
ASSUME					
Printer interface control board is in place (04B) in logic rack with switches (figure CRT 55) set per subsystem/system requirements, e.g., NIP uses 300 baud, even parity and IMP uses 1200 baud even or odd selectable parity. The printer (either NIP or IMP) is connected to display cabinet PERIPHERAL CONNECTOR and is connected to proper ac power (see Installation and Checkout, section 3). Paper is loaded in printer and printer is ready for use (procedure NIP1 or IMP1). Test Section 2 of table CRT1 (sheet 3) ran OK.					
CONDITIONS	SITUATIONS				
	1	2	3	4	5
Activate PRINT ON LINE key. Does printer begin by printing a space character, continue by printing a 79-character line, and continue printing successive 79-character lines in a one-character-left shifting pattern? (See Printer Diagnostic Test Pattern in appendix C).	Y	Y	Y	N	
Caution: Do not allow a printer to constantly print continuous adjacent columns for more than 5 minutes maximum at a time or solenoid assemblies will overheat and be damaged. Press any alphanumeric key to exit printout and to activate Test Section 7 of table CRT1 (sheet 5). Does terminal configuration code displayed (figure CRT58) indicate printer function present?	Y	Y	N	-	O T H E R
Place TEST/NORMAL switch to NORMAL. Press MASTER CLEAR. Refer to terminal subsystem operator's guide and check operation of all printer control keys (line feed, carriage return, backspace, etc.) by composing a message using these keys and sending it to the printer. Also check each of the printer message transmission keys (PAGE PRINT, PRINT ON LINE, and PRINT LOCAL) by sending the printer control messages with each of these keys. Does proper data go to printer in all cases (as evidenced by proper printer actions)?	Y	N	-	-	
ACTIONS	SEQUENCE				
Printer interface control operation checks OK. Proceed to DDLT for next function/equipment in subsystem.	X	-	-	-	-
Observe for proper printed circuit board seating.	-	1	1	1	-
Check I/O cable connections from display to printer.	-	2	-	2	-
Observe backpanel connections.	-	3	2	3	-
Replace printer interface control board 04B (procedure CRT8).	-	4	3	4	-
Replace processor board 09 (procedure CRT8).	-	5	5	5	-
Replace ROM/RAM board 08 (procedure CRT8). If same error recurs, replace Extended Memory board 05B (procedure CRT8).	-	6	4	6	-
Use table NIP1 or IMP1 (DDLTS for NIP and IMP) and troubleshoot printer connected in subsystem. When done, return to this table.	-	9	-	7	-
Check keyboard cable and connector.	-	7	-	8	-
Replace keyboard printed circuit board (procedure CRT18).	-	8	-	9	-
Call next level of support.	-	10	6	10	X
Note: After completing any repairs or maintenance, verify that the subsystem is fully operational by rerunning test mode.					

TABLE CRT9. DDLT FOR TCU INTERFACE CONTROL FUNCTION IN DISPLAY TERMINAL

TAPE CASSETTE UNIT INTERFACE CONTROL OPERATION CHECKS				
ASSUME				
Tape cassette unit interface control board is in place (07) in logic rack with switch (figure CRT55) set per system requirements. A tape cassette unit (either single or dual) is connected to display cabinet PERIPHERAL CONNECTOR and is connected to proper ac power (see Installation and Checkout, section 3). Scratch tape(s) loaded in tape drive(s) and unit is ready for use (procedure TCU1). Test Sections 0 through 2 of table CRT1 (sheets 1 through 3) ran OK.				
CONDITIONS	SITUATIONS			
	1	2	3	4
Press spacebar four times to skip to Test Section 7 of table CRT1 (sheet 5). Does terminal configuration code displayed (figure CRT58) indicate cassette function present?	Y	Y	N	
Place TEST/NORMAL switch to NORMAL. Press MASTER CLEAR. Refer to terminal subsystem operator's guide and check operation of all tape control keys (search, backskip, and read) by using each of these keys. Also check write/read capability by composing a message and sending it to tape unit (appendix C shows a recommended, full-screen, tape unit test pattern which may be composed on the display screen and sent-to/received from tape units for test exercising). Does proper operation occur as described in operator's guide (as evidenced by proper tape unit action and proper messages read back from tape)?	Y	N	-	O T H E R
ACTIONS	SEQUENCE			
Tape cassette unit interface control operation checks OK. Proceed to DDLT for next function/equipment in subsystem.	X	-	-	-
Observe for proper printed circuit board seating.	-	1	1	-
Check I/O cable connections from display to tape unit.	-	2	-	-
Observe backpanel connections.	-	3	2	-
Replace tape cassette unit interface control board 07 (procedure CRT8).	-	4	3	-
Replace processor board 09 (procedure CRT8).	-	5	5	-
Replace ROM/RAM board 08 (procedure CRT8). If same error recurs, replace Extended Memory board 05B (procedure CRT8).	-	6	4	-
Check keyboard cable and connector.	-	7	-	-
Replace keyboard printed circuit board (procedure CRT8).	-	8	-	-
Use table TCU1 and troubleshoot tape unit connected in subsystem. When done, return to this table.	-	9	-	-
Call next level of support.	-	10	6	X
Note: After completing any repairs or maintenance, verify that the subsystem is operational by rerunning test mode.				

TABLE CRT10. DDLT FOR +5-V REGULATOR SLAVE FUNCTION IN DISPLAY TERMINAL

+5-V REGULATOR SLAVE OPERATION CHECKS			
ASSUME			
+5-V regulator card is in slave position (01A) in logic rack in addition to a +5-V regulator in master position (03A) in rack.			
CONDITIONS	SITUATIONS		
	1	2	3
Using procedure CRT22, check slave +5-V regulator output. Does output check OK?	Y	N	OTHER
ACTIONS	SEQUENCE		
+5-V regulator slave operation checks OK. Proceed to DDLT for next function/equipment in subsystem.	X	-	-
Replace slave +5-V regulator (procedure CRT8).	-	1	-
Using sheet 1 of table CRT1, troubleshoot until +5-V regulator slave is operational.	-	2	-
Call next level of support.	-	-	X
Note: After completing any repairs or maintenance, verify that the subsystem is operational by rerunning test mode.			

TABLE CRT11. DDLT FOR PAGING FUNCTION IN DISPLAY TERMINAL

PAGING OPERATION CHECKS: LOCAL AND ONLINE												
ASSUME												
Extended Memory board is in place (05B) in logic rack. Paging board is in place (07) in logic rack. Checks of table CRT2, DDLT for Extended Memory Function in Display Terminal completed OK. ON LINE/LOCAL switch is in LOCAL position.												
CONDITIONS	SITUATIONS											
	1	2	3	4	5	6	7	8	9	10		
Press MASTER CLEAR switch. Type in 3 or 4 lines (any characters) at top of screen and fill bottom line with characters. Press TAPE SRCH key to advance to page 2. Did information typed on screen (page 1) disappear and a fresh, blank screen appear?	Y	Y	Y	Y	Y	Y	Y	Y	Y	N		
Type in 3 or 4 lines (any characters) at top of screen and fill bottom line with characters (make this composition recognizeably different from the first one already entered in page 1 RAM). Press TAPE SRCH key to advance to page 3. Did information typed on screen (page 2) disappear and a fresh, blank screen appear?	Y	Y	Y	Y	Y	Y	Y	Y	N	-		
Type in 3 or 4 lines of characters at top of screen and one at bottom as before being sure that this composition is different from either of the first two already entered in page 1 and page 2 RAMs. Press TAPE BACKSPACE key to return to page 1. Did page 1 information replace page 3 just typed?	Y	Y	Y	Y	Y	Y	N	-	-	-	O T H E R	
Press TAPE SRCH key. Did page 2 information replace page 1?	Y	Y	Y	Y	Y	N	-	-	-	-		
Press TAPE SRCH key. Did page 3 information replace page 2?	Y	Y	Y	Y	N	-	-	-	-	-		
With pages 1, 2, and 3 still stored in RAM, if system allows, request/receive DC1 and DC3 codes (with ON LINE/LOCAL switch in ON LINE position) from host system to verify system-initiated paging operations. Did DC1 (021g) initialize the display to page 1?	Y	Y	Y	N	-	-	-	-	-	-		
Did DC3 (023g), received while displaying page 1, advance the display to page 2?	Y	Y	N	-	-	-	-	-	-	-		
Did DC3 (023g), received while displaying page 2 advance the display to page 3?	Y	N	-	-	-	-	-	-	-	-		
ACTIONS	SEQUENCE											
Paging operation checks OK. Proceed to DDLT for next function/equipment present in the subsystem.	X	-	-	-	-	-	-	-	-	-		
Observe for proper printed circuit board seating.	-	1	1	1	1	1	1	1	1	-		
Replace paging board 07 (procedure CRT8).	-	2	2	2	2	2	2	2	2	-		
Replace processor board 09 (procedure CRT8).	-	3	3	3	3	3	3	3	3	-		
Observe backpanel connections.	-	4	4	4	4	4	4	4	4	-		
Replace ROM/RAM board 08 (procedure CRT8).	-	-	-	-	-	-	5	-	-	-		
Replace refresh board 06 (procedure CRT8).	-	-	-	-	-	-	-	-	5	-		
Check keyboard cable and connector for proper seating.	-	-	-	-	5	5	6	5	6	-		
Replace keyboard printed circuit board (procedure CRT18).	-	-	-	-	6	6	7	6	7	-		
Check/replace ON LINE/LOCAL switch (procedures CRT10 and CRT28).	-	-	-	5	-	-	-	-	8	-		
Call next level of support.	-	5	5	6	7	7	8	7	9	-		
Note: After completing any repairs or maintenance, verify that the subsystem is fully operational by rerunning test mode.												

Procedure CRT1 — Turning On Keyboard Display Power

To turn on keyboard display power, perform the following:

- 1) Verify that ac power cord is connected to proper site power outlet (specifications, section 1, defines power requirements).

NOTE

It is recommended that the keyboard be connected or else the +5-V regulator board be in its place before turning on display power. This is a prevention against improper voltages causing erratic operation of monitor and subsystem after a power ON.

- 2) Place white, toggle-type, breaker switch on rear panel to up position. If it trips, see table CRT1, DDLT for Display Terminal and start troubleshooting at sheet 1.
- 3) Press POWER ON/OFF switch on front panel to ON — it should illuminate; if not, see table DDLT for Display Terminal, and start troubleshooting at sheet 1.

Procedure CRT2 — Turning Off Keyboard Display Power

To turn off keyboard display power, perform the following:

- 1) Press POWER ON/OFF switch on front panel to OFF — it should extinguish.
- 2) If desired to remove all power beyond the ac entry panel, place white, toggle-type, breaker switch on rear panel to down position.
- 3) If desired to remove all power applied to the keyboard display cabinet (such as for removing the ac entry panel or just to be doubly safe when working inside the display cabinet), disconnect ac power cord from site power outlet.

NOTE

When POWER ON/OFF switch is pressed OFF, allow 60 seconds to elapse before pressing ON again or the circuit breaker may trip.

Procedure CRT3 — Replacing High-Voltage Transformer

- 1) Turn power off (procedure CRT2) and disconnect ac power cord.

WARNING

Be careful not to scratch surface of cathode-ray tube. A scratch weakens the glass substantially and can cause the tube to implode.

- 2) Connect a heavily insulated wire to ground first and then, while carefully lifting rubber anode cover, discharge surface under rubber cover (including anode terminal end) by sliding end of grounded wire under the rubber cover and into anode hole of cathode-ray tube.
- 3) Remove high-voltage lead by raising rubber cover and gently compressing spring-loaded anode lead.
- 4) Remove transformer's primary wires from connector BP4. Do this by inserting end of paper clip into top of connector between flag-type terminal and insulation to release each wire (figure CRT21). Tag/mark wires according to BP4 numbers (figures CRT1 and CRT2).
- 5) On transformers with paper insulators, remove high-voltage lead from paper insulator attached to standoff. Remove screw attaching high-voltage lead insulator to hexagon standoff and remove insulator. Remove hexagon standoff and hexagon nut (and washers) holding transformer to chassis, and carefully withdraw transformer from video module.

On transformers with plastic insulators, the insulator is a part of the high-voltage lead. Remove two hexagon nuts and their washers attaching transformer to the chassis to free the insulator, and carefully withdraw transformer from video module.

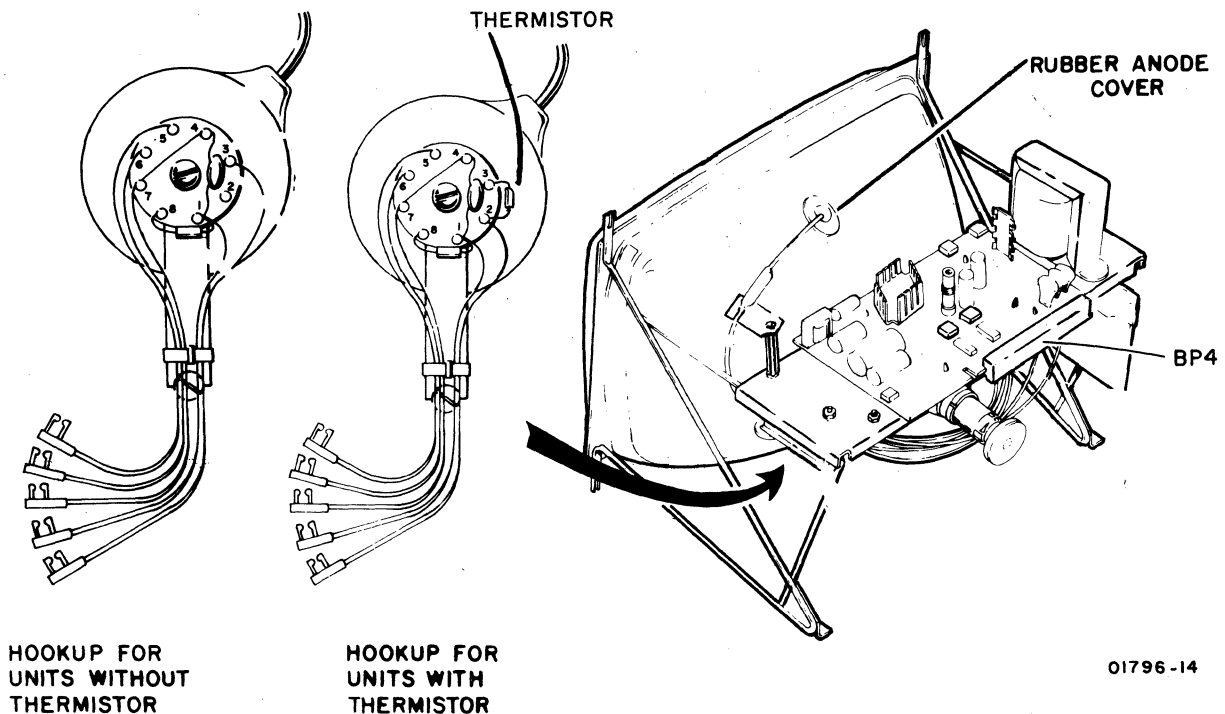

Figure CRT1. High-Voltage Pin Numbers

To replace transformer, perform the following:

- 6) Connect transformer to chassis as shown in figure CRT2.
- 7) On transformers with paper insulators, connect high-voltage lead through hole in paper insulator and then to anode of crt. On transformers with plastic insulators, position boot and form high-voltage lead so lead has a minimum clearance of 0.5 inch from crt and metal parts. Then secure in place with plastic insulator.

WARNING

Connection may be hard. If using pliers to help connect, be extremely careful. Recommended that plier tips be covered by heat shrink tubing to prevent accident with the CRT.

- 8) Connect flag-type terminals on primary wires to connector BP4:

T1-8 to BP4-16
T1-2* to BP4-17
T1-5 to BP4-13
T1-6 to BP4-5
T1-7 to BP4-14

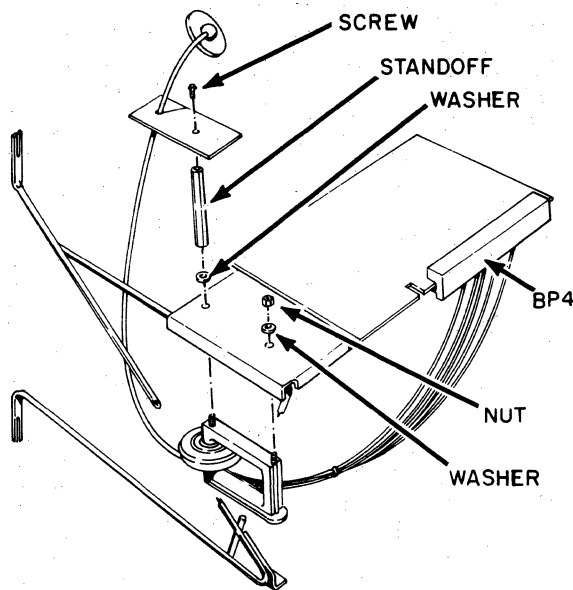

HIGH-VOLTAGE TRANSFORMER
WITH PAPER INSULATOR

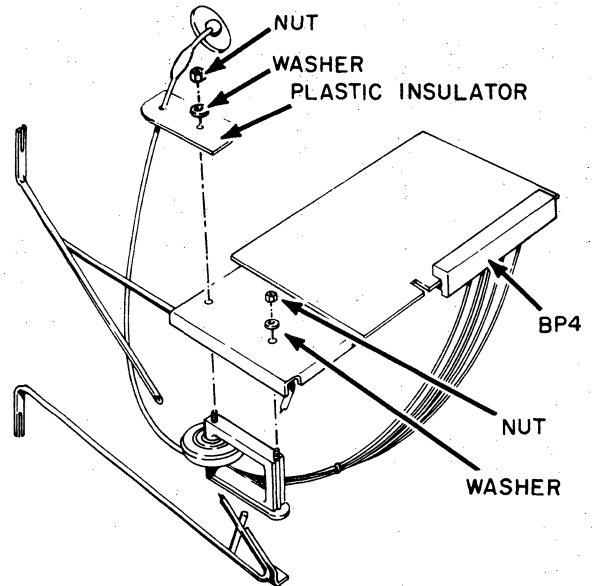

HIGH VOLTAGE TRANSFORMER
WITH PLASTIC INSULATOR

01796-13

Figure CRT2. High-Voltage Transformer Installation

* T1-2 connection for use only when thermistor is used. If thermistor is not used on monitor this connection should be T1-3.

Procedure CRT4 — Replacing Video Module +15-V dc Regulator

There are two versions of +15-V dc regulator assemblies. The early design is identified by its rectangular shaped regulators. The newer versions have a round shaped transistor and regulator. Replacement procedures differ slightly between the two versions of regulator assemblies; these differences are explained below.

NOTE

The latest version regulator assembly has a fuse F1 across its input. Check this fuse first to see if it is blown when servicing or doing this procedure.

To remove the regulators and/or transistor mounted on the +15-V dc regulator assembly (figure CRT3) perform the following:

- 1) Turn power off (procedure CRT2) and disconnect ac power cord.
- 2) On early versions (figure CRT3), remove defective regulator(s) by turning out screw(s) that hold it to heat sink, grasp case firmly, and pull from socket. On newer version, remove both the regulator and pass transistor (figure CRT3) by removing the two screws and lockwashers which hold each of them to heat sink, and pull them from their socket.

To replace +15-V dc regulator and transistor, perform the following:

NOTE

It is recommended that, on the newer version regulator, both the transistor and regulator be replaced even though only one is at fault.

- 3) Clean surface of heat sink where regulator or transistor mounts and apply thermal compound (CDC 94657900) between this surface and mica insulating washer.
- 4) Apply thermal compound to bottom of regulator or transistor and plug into socket (figure CRT3). With mounting holes aligned, fasten to heat sink with mounting screws and lockwashers.

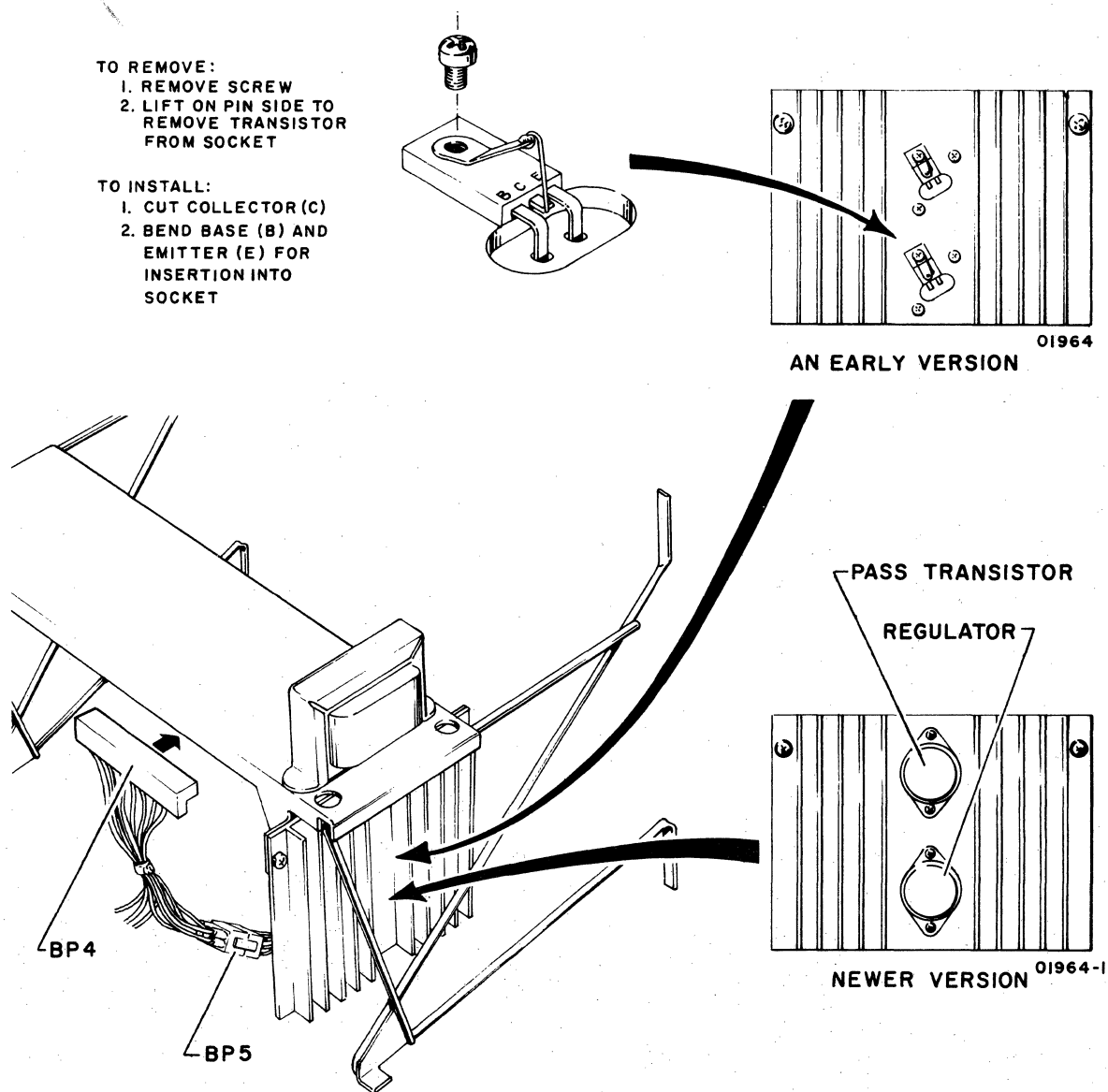

Figure CRT3. +15-V Regulator Assembly

To make output voltage checks, perform the following:

- 5) Disconnect BP5 connector (figure CRT3), apply power to display cabinet. Check for $+15 \pm 0.75$ V dc between either pins 1 or 3 of connector BP5 and pin 2 of BP5 which is ground (figure CRT4). If output voltage is within tolerance, proceed to the next step. If output voltage is not within tolerance, replace entire +15-V dc regulator assembly and check voltage again.
- 6) Turn power off and reconnect BP5 connector. Apply power and check for +15-V dc underload per steps 15 through 20 of procedure CRT20.
- 7) If voltage drops below +14.25 V dc with BP4 connected, replace video printed-circuit board (procedure CRT11).

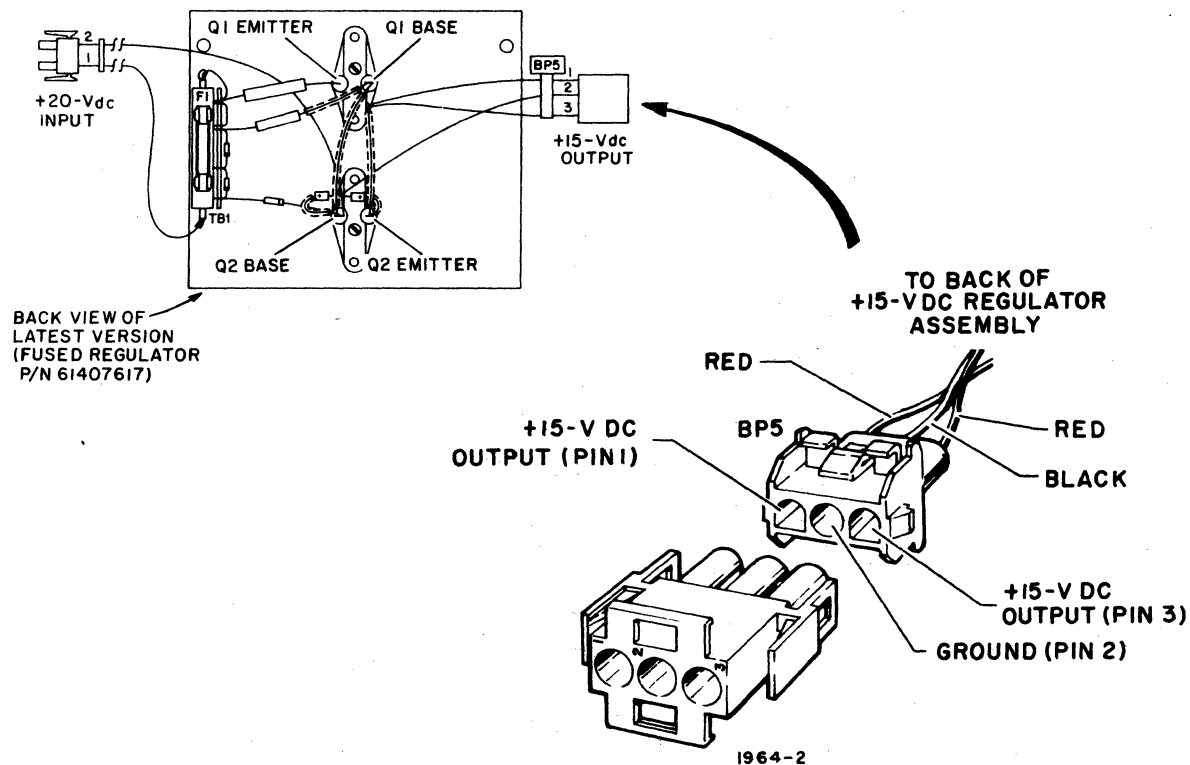

Figure CRT4. BP5 Connector Pins

Procedure CRT5. — Replacing Display Terminal ac Entry Panel

To remove ac power panel assembly, refer to figures CRT5 and CRT61 and perform the following:

- 1) Turn power off (procedure CRT2).
- 2) Remove ac plug from site power outlet.
- 3) Remove four screws which anchor panel box to cabinet chassis.
- 4) Remove grounding wires connected to terminals E2, E3, and E4 (3/8 inch hex nuts).
- 5) Disconnect connector CP3 leading to power ON/OFF switch (CP3).
- 6) Disconnect connector CP2 leading to transformer and bulk power supply (CP2).
- 7) Withdraw entire ac power panel and its connectors from cabinet.

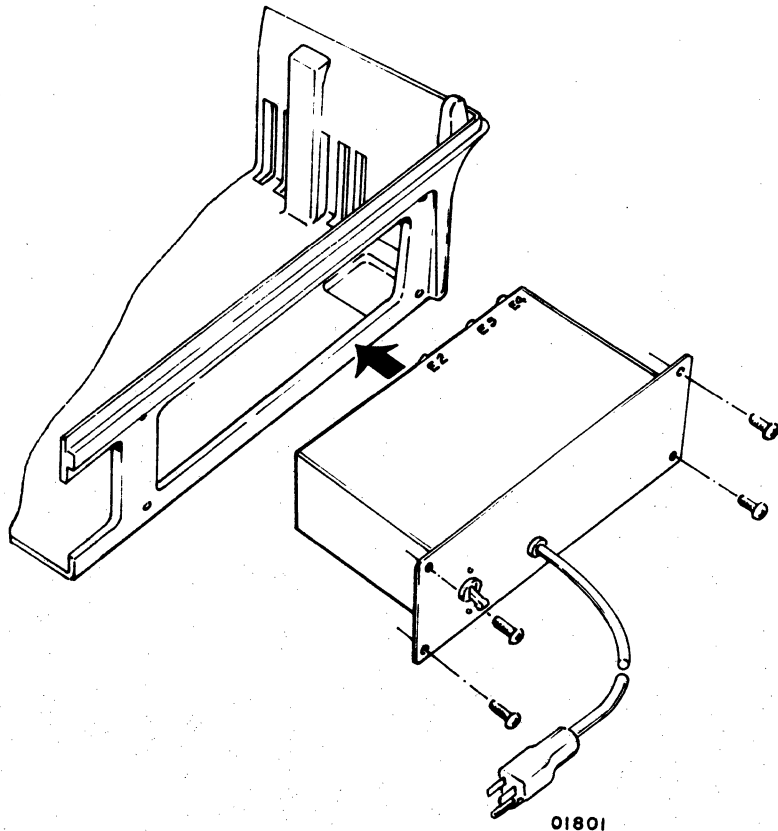

Figure CRT5. AC Entry Panel Removal

To install ac entry panel, perform the following:

- 8) Feed connectors through chassis hole and insert ac power panel (box) into chassis compartment.
- 9) Fasten four screws (figure CRT5).
- 10) Attach grounding wires to E2, E3, and E4. Ensure that lockwasher contacts ac entry panel surface for proper ground.
- 11) Connect cable connectors (small one, CP3, goes to POWER ON/OFF switch while large one, CP2, leads to bulk power supply).

Procedure CRT6 — Replacing Display Terminal TEST/NORMAL Switch

To remove TEST/NORMAL switch, perform the following:

- 1) Turn power off (procedure CRT2) and disconnect ac power cord.
- 2) Remove data cables from rear panel and remove four mounting screws holding data entry panel to chassis (figure CRT6).
- 3) Remove the TEST/NORMAL switch (slide switch below MASTER CLEAR pushbutton switch) from the panel by unscrewing two screws holding the switch to the panel.
- 4) Remove wires and identify them so they can be replaced correctly (figure CRT6).

To replace TEST/NORMAL switch, perform the following:

- 5) Attach wires to pins of TEST/NORMAL switch in the same arrangement they were removed (figure CRT6).
- 6) Attach switch to panel with two mounting screws.
- 7) Attach panel to chassis with four mounting screws.

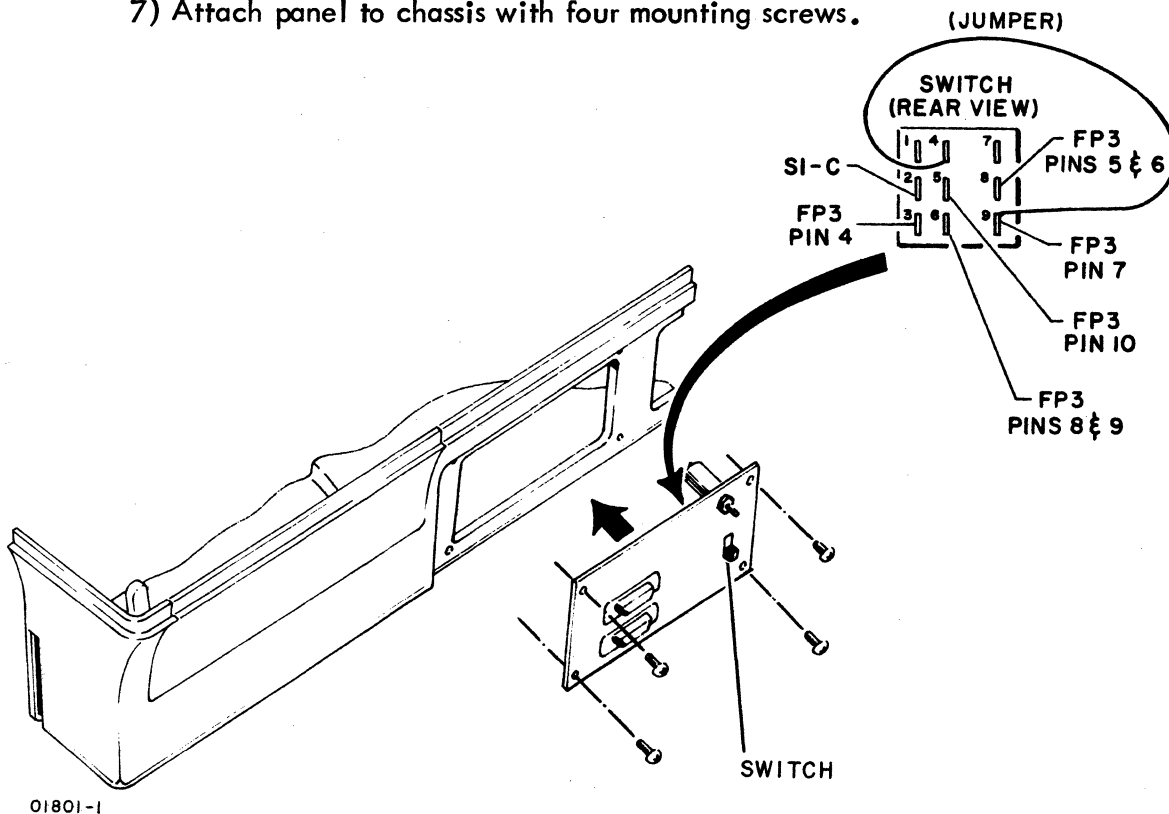

01801-1

Figure CRT6. TEST/NORMAL Switch Removal

Procedure CRT7 — Replacing Display Terminal MASTER CLEAR Switch

To remove MASTER CLEAR switch, perform the following:

- 1) Turn power off (procedure CRT2) and disconnect ac power cord.
- 2) Remove four mounting screws holding data entry panel to chassis (figure CRT7).
- 3) Unscrew hex nut holding MASTER CLEAR switch to panel.
- 4) Remove wires and identify them for proper reconnection.

To replace MASTER CLEAR switch, perform the following:

- 5) Attach wires to switch pins as follows: jumper (GND) from S2-2 to S1-center, wire from connector FB3-2 to S1-NO, and wire from connectors FB3-3 to S1-NC.
- 6) Insert switch into panel and attach with hex nut.
- 7) Attach panel to chassis with four mounting screws.

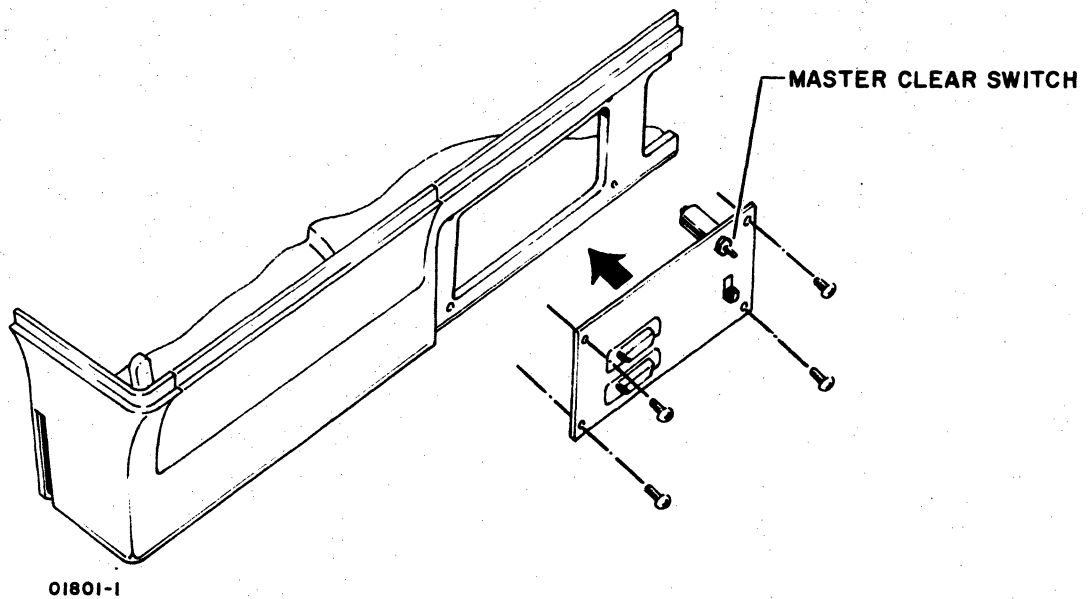

Figure CRT7. MASTER CLEAR Switch

Procedure CRT8 — Replacing Boards in Logic Module Card Cage

To remove boards from card cage, perform the following:

- 1) Press POWER ON/OFF switch to OFF.
- 2) Remove two screws holding cabinet hood to chassis and remove cabinet hood.
- 3) Lift out cabinet-back insert from behind card cage.
- 4) Release friction clamp arms holding board in place.
- 5) Withdraw board from card cage.

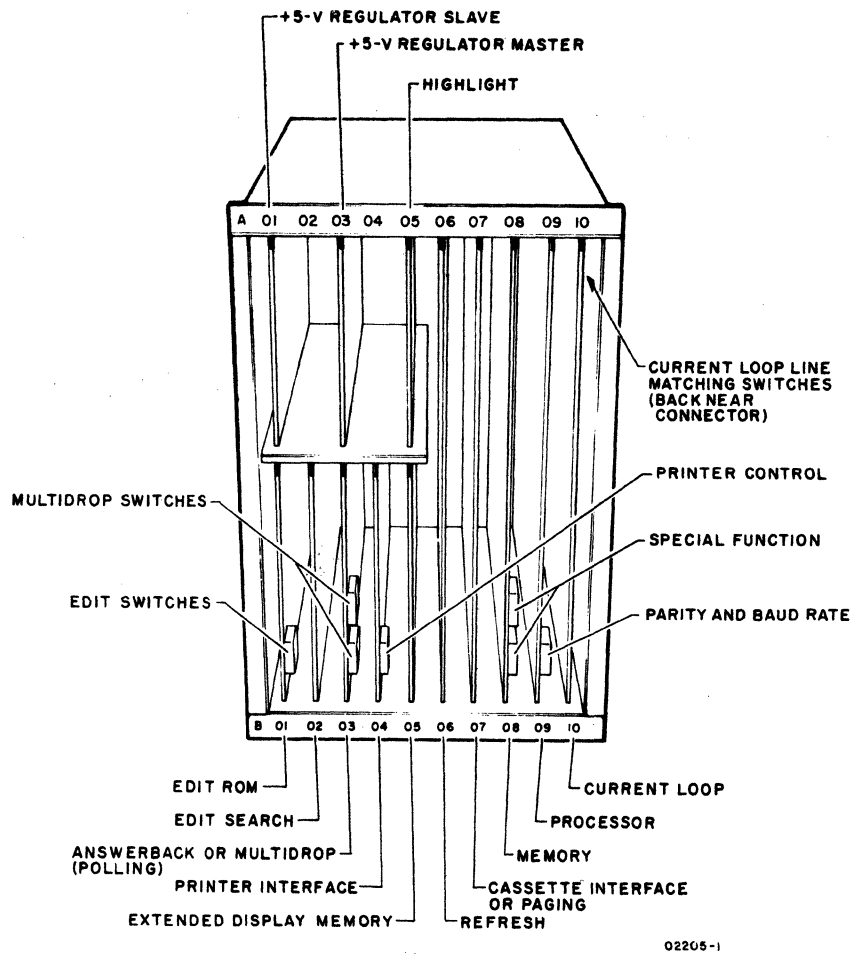

Figure CRT8. Logic Card Cage Board Locations

To replace boards in card cage, perform the following:

- 6) Turn power off by pressing POWER ON/OFF switch to OFF.
- 7) Place board in correct location (figure CRT8) and slide board in track until board is touching socket at end of track.
- 8) Carefully draw board into socket by locking friction clamps.
- 9) If board contains switches, check/set settings of such switches (figure CRT55) per terminal-application requirements.
- 10) Replace cabinet-back insert behind card cage.

Procedure CRT9 — Replacing Logic Module Card Cage

To remove logic module card cage, perform the following:

- 1) Press POWER ON/OFF switch to OFF.
- 2) Remove four mounting screws, using 5/16-inch socket and 19-inch by 1/4-inch drive extension (figure CRT9).
- 3) Lift card cage carefully upward and to rear sufficiently to access connectors mounted on bezel side of card cage (figure CRT59). When cage is back far enough, label connectors as required to ensure proper reconnection. Disconnect cables (as outlined following) and remove card cage (figure CRT9).

Disconnect connector cables:*

- API
- A08A07
- A09A33
- A10A45
- A07B47
- A06A57
- Two green grounding wires from lower right rear of card cage

To replace logic module card cage, refer to figure CRT59 and reverse the preceding steps. After replacing, be sure to verify settings of all switches (figure CRT55) per terminal-application requirements.

* It is not necessary to remove the individual dc power lead connectors from the backplane since this dc cable can be removed with the logic module cage. To remove dc cable, verify that it is unplugged from the bulk power supply and that the single lead is disconnected from the ac entry module.

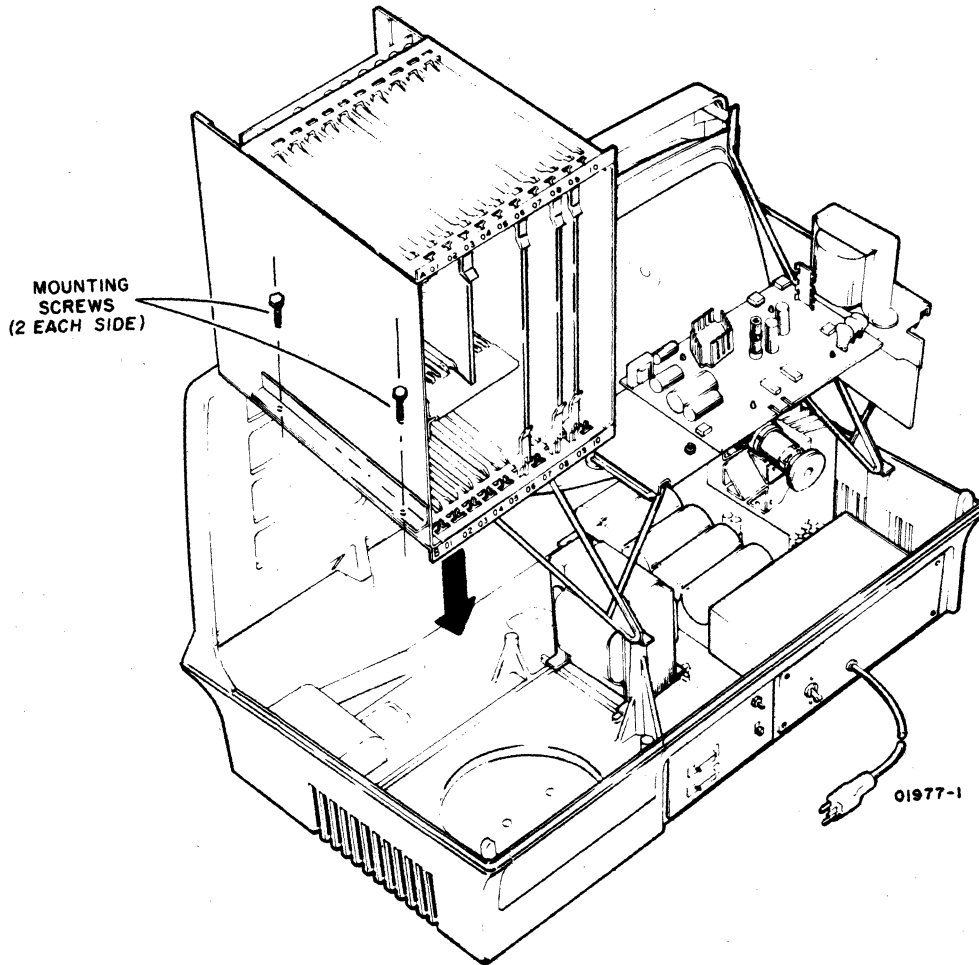

Figure CRT9. Logic Module Card Cage Removal

Procedure CRT10 — Replacing Display Terminal Switches, Indicators, and Panels

To remove an indicator or switch, or entire panel, perform the following:

- 1) Turn power off (procedure CRT2) and disconnect ac power cord.
- 2) Separate panel from bezel by inserting fingers under panel and carefully prying panel from bezel chassis (see arrows in figure CRT10).
- 3) Disconnect all wires from indicator board/switch/indicator by pulling terminals and identify wires.

Replace entire LED board/switch/indicator with new board/switch/indicator by reversing the preceding procedure.

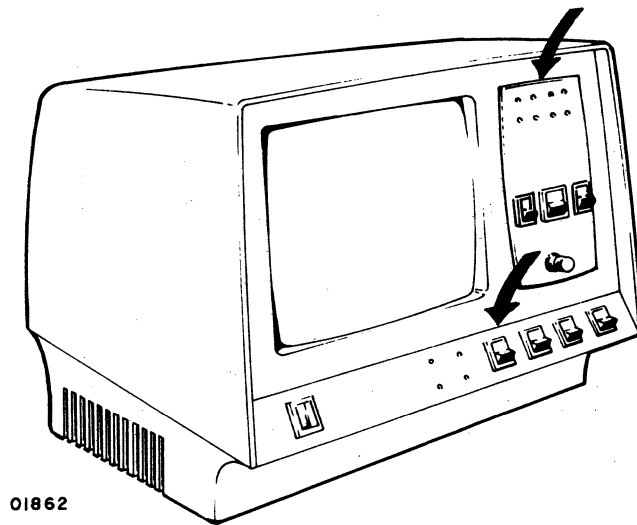

Figure CRT10. LED and Switch Panel Removal

Procedure CRT11 — Replacing Video Printed-Circuit Board

To remove video printed-circuit board, perform the following procedures:

- 1) Turn power off (procedure CRT2) and disconnect ac power cord.
- 2) Disconnect connector BP1 (see figure CRT11).
- 3) Disconnect ground wire BP7 from location BJ7 on video board.
- 4) Disconnect crt lead BP6 from location BJ6 and disconnect ground wire BP8 from location BJ8.

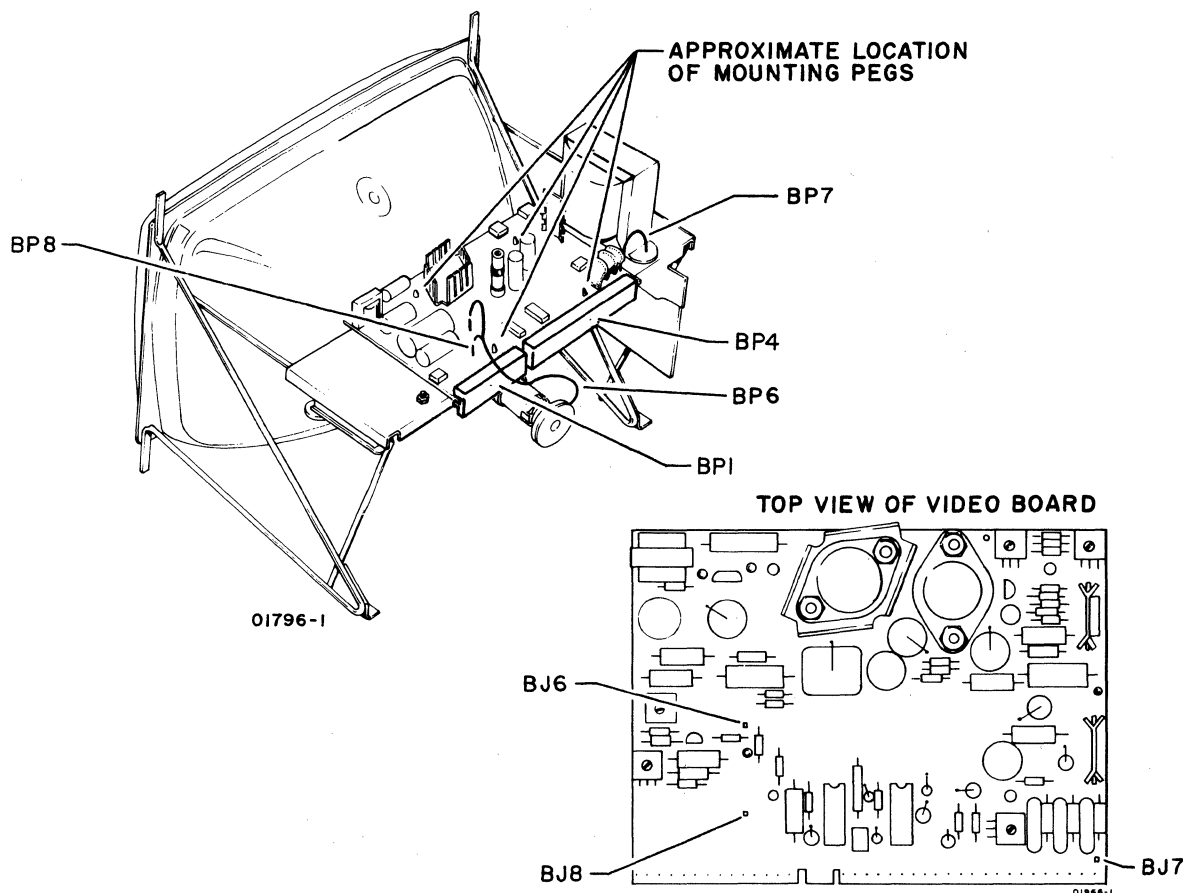

Figure CRT11. Video Module Printed-Circuit Board Connections

- 5) Disconnect connector BP4.
- 6) To remove PC board from the four plastic mounting pegs attached to video module, (figures CRT11 and CRT12) very carefully compress the mounting peg retainer clip (see insert in figure CRT12) while at the same time gently lifting that portion of PC board until the board is free from the retainer clip; then stop lifting. Do the same procedure to the remaining pegs. When free of all four retainer clips pull PC board all the way up and off the mounting pegs.

CAUTION

To avoid breaking plastic use extreme care when compressing mounting peg retainer clips. (Use P/N 51777314 to order replacement mounting pegs.) Make sure all four retainer clips are compressed before lifting PC board all the way up, off the video module. Stress damage results if board is twisted off because a clip was not fully compressed.

To replace video printed-circuit board, perform the following:

- 7) Install new printed-circuit board by positioning board over mounting pegs (match holes on printed-circuit board with pegs) and gently pressing board down into position (figure CRT12) so that retainer clips on pegs pass through holes sufficiently to lock board in place.
- 8) Replace connectors BP1, BP4, BP6 and ground wires BP7 and BP8.
- 9) Refer to procedure CRT26 for video adjustments, if required for proper display.

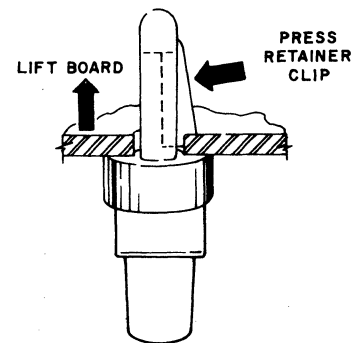
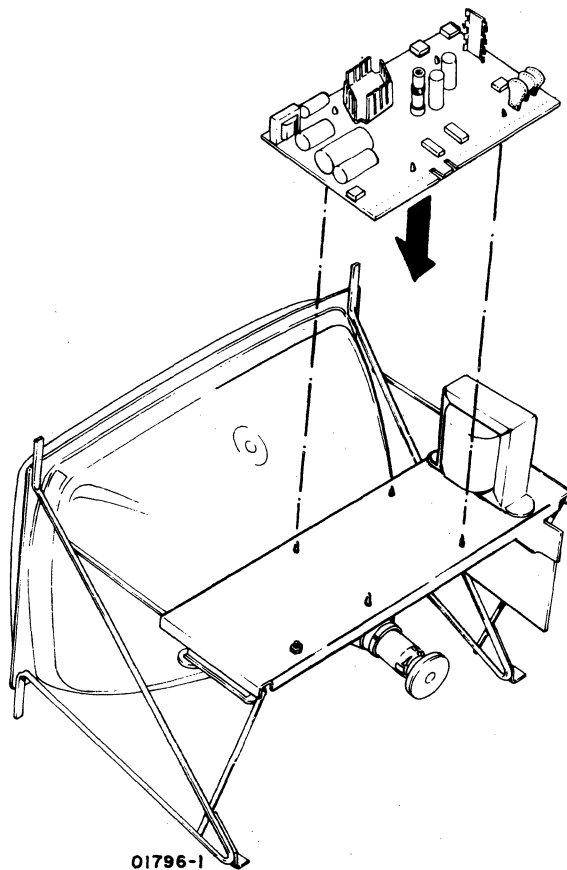

REMOVING PC BOARD FROM MOUNTING PEG

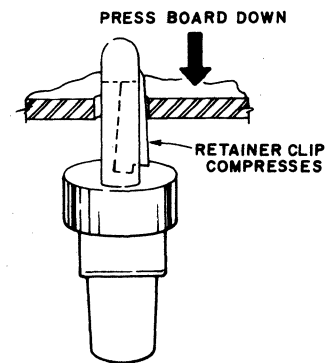

INSTALLING PC BOARD OVER MOUNTING PEG

Figure CRT12. Video Printed-Circuit Board Placement

Procedure CRT12 — Replacing Display Terminal Video Module

To remove video module, perform the following:

- 1) Turn power off (procedure CRT2) and disconnect ac power cord.

- 2) Disconnect flag terminal 14 from BP1 connector (from crt ground clip) by inserting small end of paper clip into top of connector in space available between flag terminal and insulation (see figure CRT13) and then pulling out wire gently from bottom of connector. (Flag terminal end has a wedge-type spring clip which, when released by paper clip, permits flag terminal to be withdrawn with wire from connector.)*
- 3) Refer to figure CRT13 and disconnect connector BP1.
- 4) Disconnect connectors BP2 and BP3.
- 5) Disconnect all ground wires from E1 by video board.

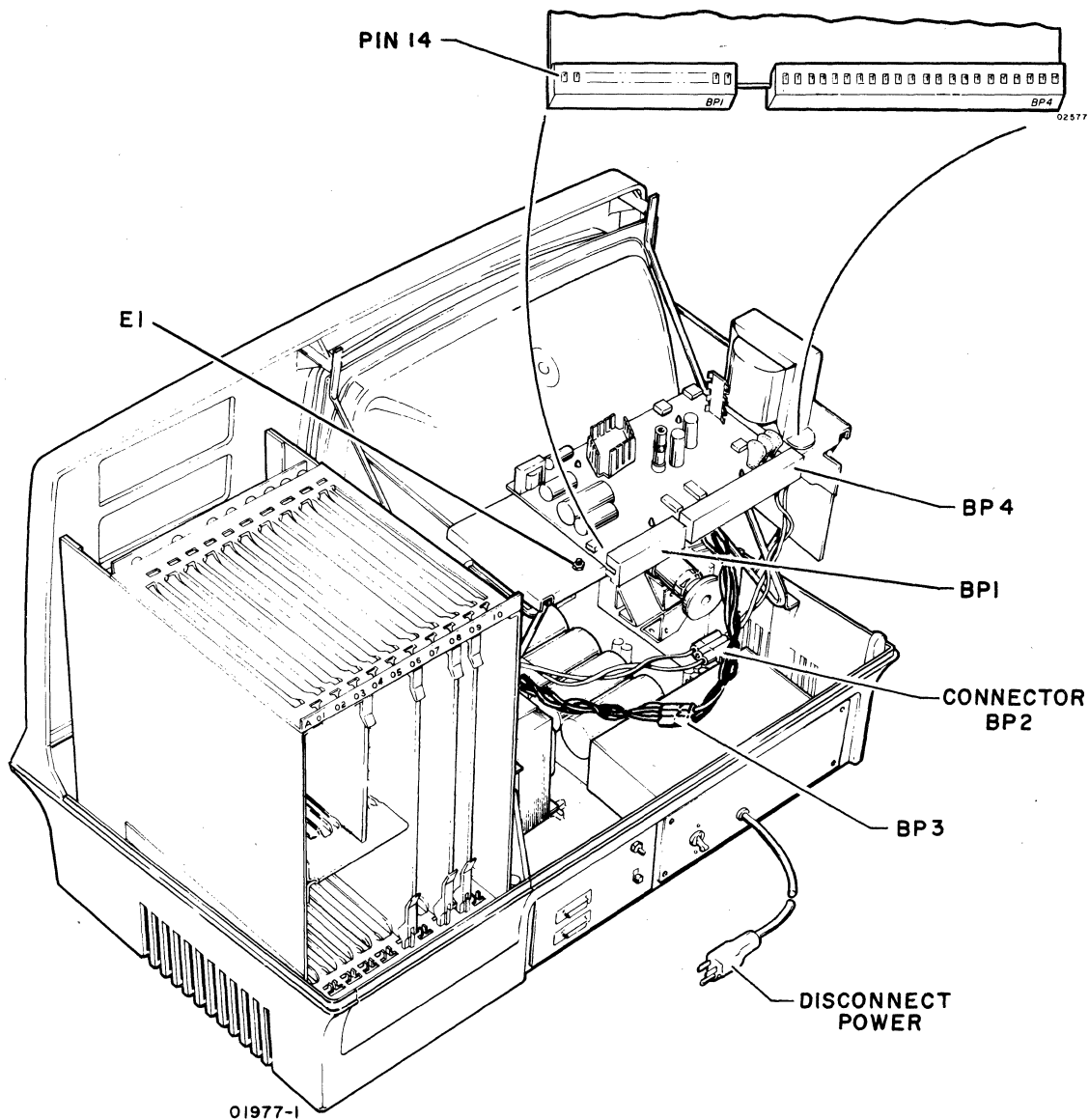

Figure CRT13. Video Module Connector Removal

* Step 2 not applicable unless video display assembly is part number 61370905.

- 6) Loosen (do not remove) the bottom two hex screws as shown in figure CRT14. (Slots in bottom of frame brackets allow them to be moved out without removing screws.) Remove the remaining four hex screws by using a 1/4-inch socket and extension. See figure CRT14 for the locations of the four hex screws.

WARNING

Use extreme care when handling the TV module because rough handling can cause the crt to implode with tremendous force resulting in severe injury. Do not nick or scratch glass or subject it to any undue pressure during replacement. When handling crt, always wear safety goggles and heavy gloves for protection.

- 7) Grasp video module by mounting frames with both hands and carefully withdraw entire module from cabinet (see figure CRT15). Check to see that neck of crt or mounting frame is not caught on cabling.

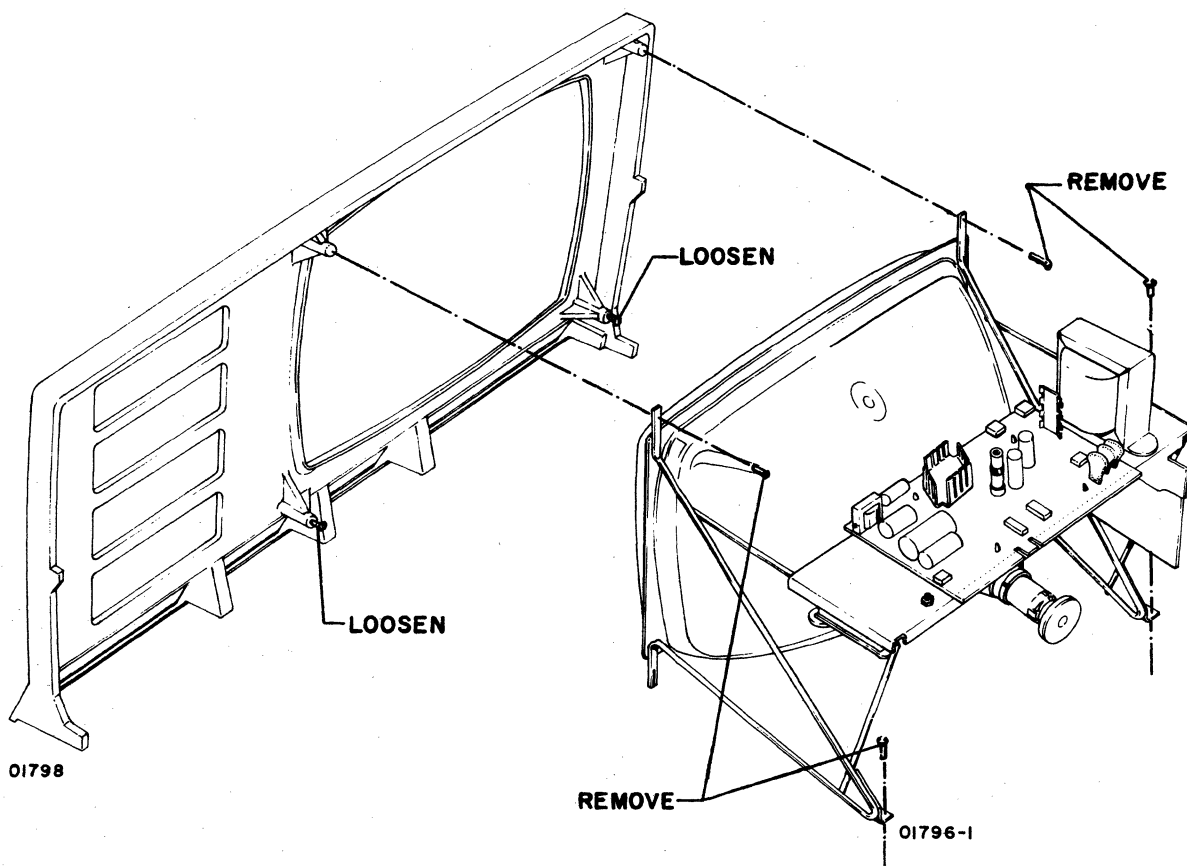

Figure CRT14. Video Module Mounting Screws Removal

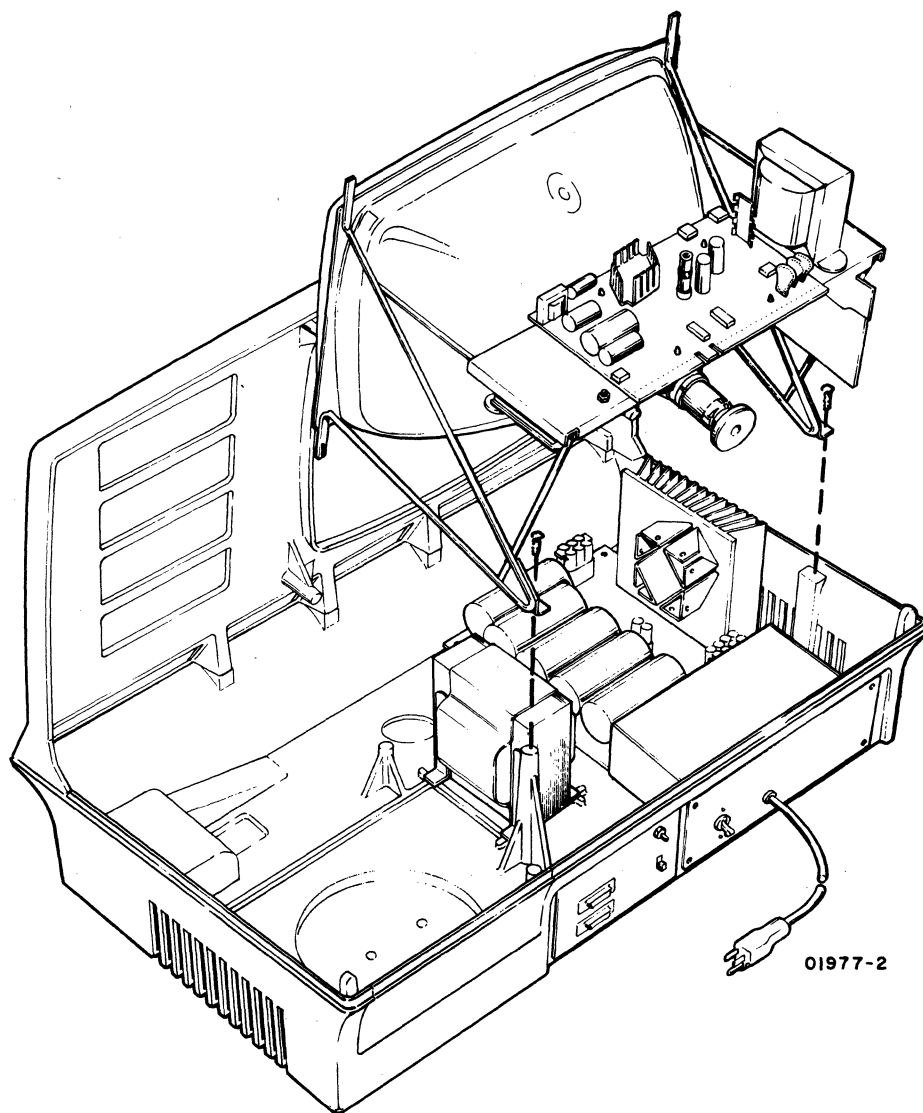

Figure CRT15. Video Module Removal

To install video module, perform the following:

- 8) Verify left-bottom and right-bottom hex screws are both partially screwed into mounting supports on bezel (figure CRT16).
- 9) With video module in both hands, lower module into cabinet until slotted support in front fits over screws inserted partially in mounting (step 7).
- 10) Carefully steady module with one hand and insert top-left and top-right screws with other hand.
- 11) Tighten two top screws just snug using 1/4-inch socket. Do not overtighten.

- 12) Insert two cabinet screws which hold back of module in place. Do not tighten.
- 13) Tighten lower-left and lower-right hex screws just snug using an 18-inch extension with a 1/4-inch socket. Do not overtighten.
- 14) Tighten back two screws just snug. Do not overtighten.
- 15) Connect printed-circuit board BP1 connector and connect crt ground clip flag pin to BP1-14. Also connect BP2, BP3, and all ground wires to E1.
- 16) Check that all other connectors (tube socket, BP4, and transformer lead into anode) are plugged in or attached correctly.

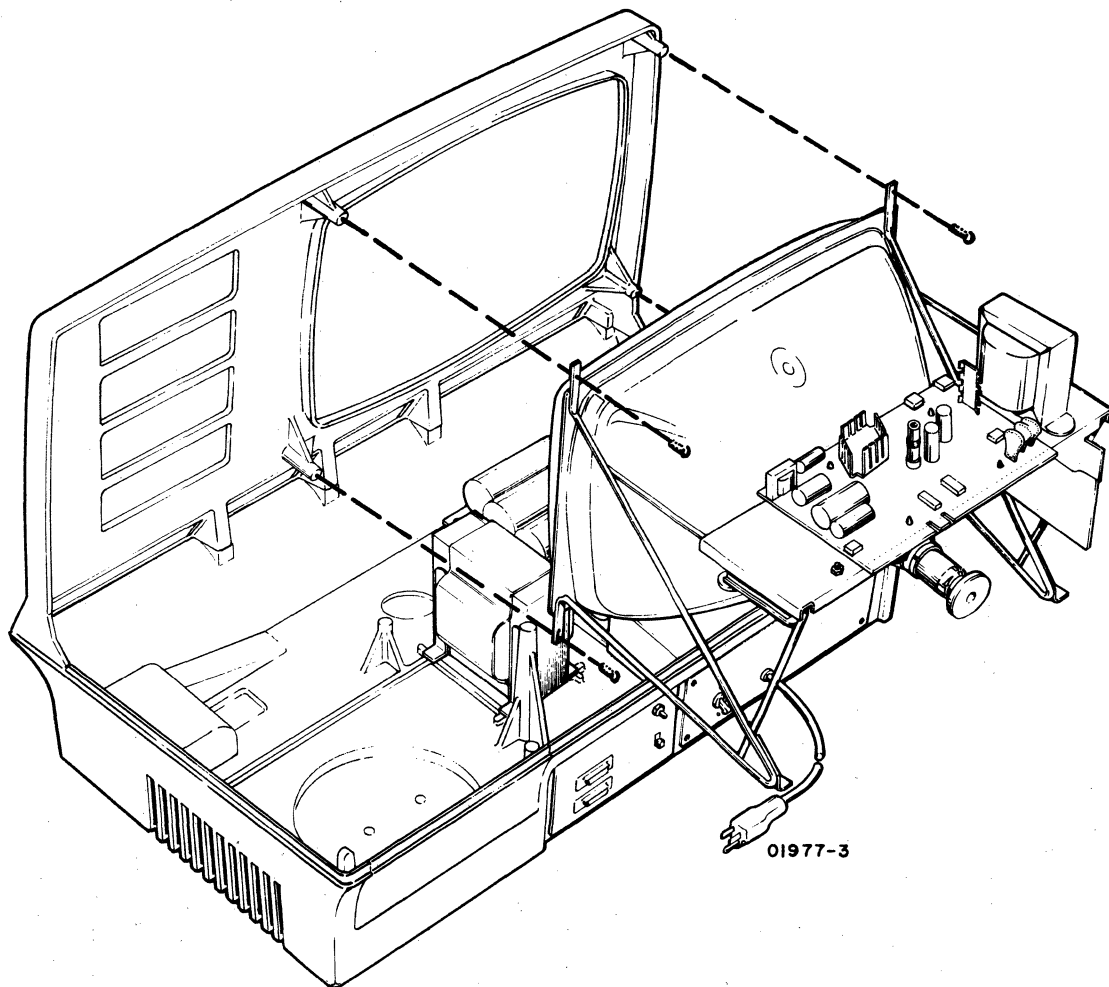

Figure CRT16. Video Module Installation

Procedure CRT13 — Replacing Display Terminal CRT

To remove crt, perform the following:

- 1) Turn power off (procedure CRT2) and disconnect ac power cord from site power outlet.
- 2) Refer back to procedure CRT3 and discharge/disconnect crt high-voltage lead by steps 1, 2, and 3.
- 3) Remove video module from cabinet (see procedure CRT12, steps 1 through 7).

WARNING

Use extreme care when handling the TV module because rough handling can cause the crt to implode with tremendous force resulting in severe injury. Do not nick or scratch glass or subject it to any undue pressure during replacement. When handling crt, always wear safety goggles and heavy gloves for protection.

- 4) Pull crt tube socket carefully from end of neck of crt (see figure CRT17). Do not remove vinyl keyguide, which should be in position over end of tube for protection when socket is removed. During installation, keyguide assures that socket is correctly positioned.
- 5) Disconnect crt ground clip assembly ring lug from E1.
- 6) Loosen clamps on ring magnet assembly and yoke.*

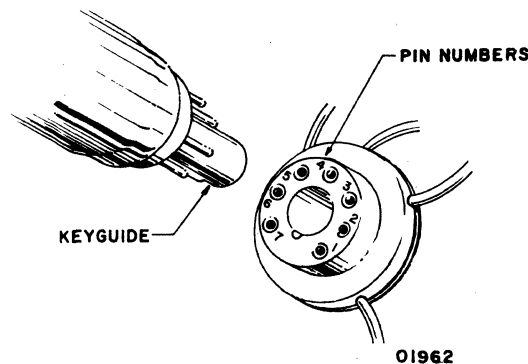

Figure CRT17. CRT Socket Removal

- 7) Remove crt ground clip from underneath shielding sleeve. Slide ring magnet assembly back on crt neck (figure CRT18) and remove. Gently slide yoke and shielding sleeve (which is between crt neck and yoke) back on crt neck to ensure it is loose enough for later removal.

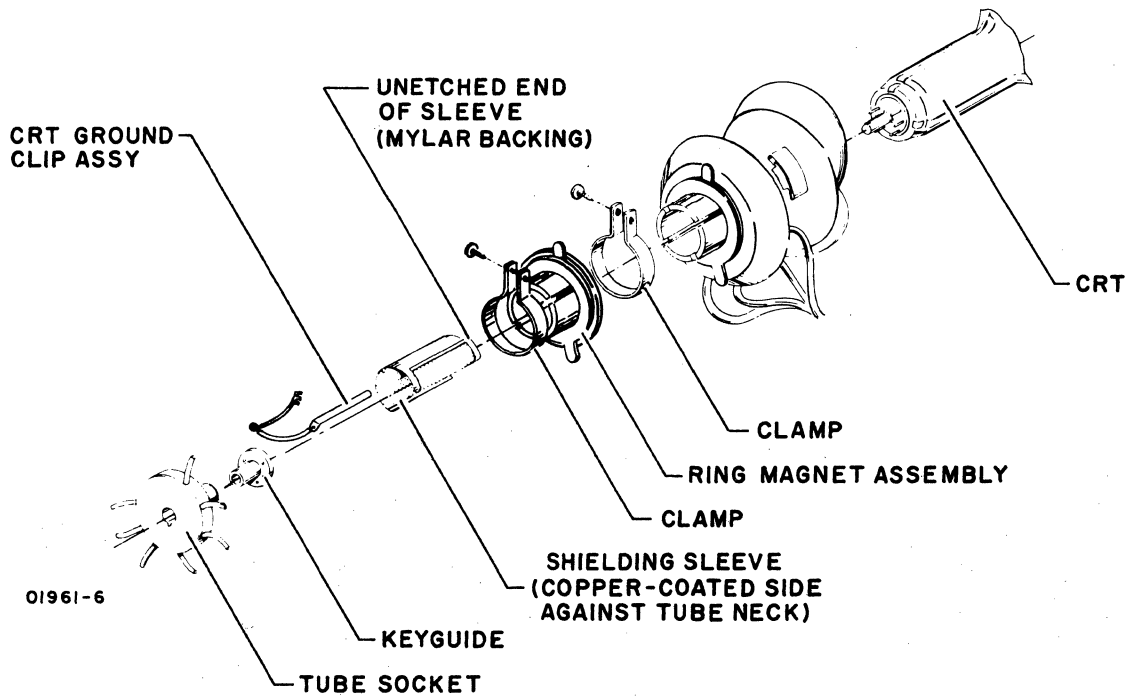

Figure CRT18. CRT Yoke Assembly

- 8) Remove four hex nuts which hold crt mounting plate to video module chassis (being careful that crt does not slip or fall when last nuts are removed). After hex nuts are removed, disconnect static discharge spring and separate mounting plate from module chassis.

WARNING

Never allow crt to rest on or be supported by its neck.

- 9) Support crt neck with one hand and carefully remove shielding sleeve and yoke with other hand.
- 10) Withdraw crt carefully from wire chassis of video module. Place crt facedown on clean, soft cloth covering flat, stable surface (bench) with neck of crt pointing upward.
- 11) Remove replacement crt from shipping carton and place on clean, soft cloth covering flat, stable surface facedown with neck pointing upward.
- 12) Place bad tube carefully into shipping carton and secure for shipment.

To install crt, perform the following:

- 13) Without resting crt on its neck, position crt for mounting on video module chassis (neck is carefully inserted into chassis frame to vicinity of yoke).
- 14) Assemble crt mounting plate to wire chassis and hook up static discharge spring. Tighten four hex mounting nuts to secure mounting plate to wire chassis.
- 15) Position shielding sleeve (figure CRT18) on neck of crt with one hand and slip yoke over neck and slide forward over sleeve. Sleeve should stick out from back of yoke (CRT19) when yoke coils are against tube.
- 16) Slip clamp over back tabs of yoke and tighten screw slightly (CRT19).
- 17) Slide ring magnet assembly over shielding sleeve and butt against yoke. Install crt ground clip between shielding sleeve and neck of crt. Tighten clamp slightly.
- 18) Assure that keyguide is in place over pins on end of crt. Keyguide is illustrated in figures CRT17 and CRT18.
- 19) Carefully position tube socket over end of crt and gently push socket into place so pins enter socket without bending.
- 20) Install video module into terminal display. Refer to steps 8 through 16, procedure CRT12.
- 21) Before power is applied to device, insert high-voltage lead from high-voltage transformer into crt anode.
- 22) Check that connectors are attached correctly to BJ1 and BJ4 of video module printed circuit board.
- 23) Perform horizontal and vertical alignment, procedure CRT14.

Procedure CRT14 — Horizontal/Vertical Linearity Adjustments

To adjust horizontal or vertical linearity, correct tilt or centering, perform the following:

- 1) If this alignment is the result of yoke having been removed or a new crt installed, check that high-voltage lead was reinstalled, printed-circuit board connectors are reconnected, and plug from +15-V dc regulator is attached to socket from logic module.
- 2) Connect ac power cord and turn power on by pressing POWER ON/OFF switch to ON position.

WARNING

With power applied, severe shock will be received if high-voltage transformer or lead to anode or area of anode on crt is touched. Be careful when following procedures are performed not to touch anything higher than yoke. Keep tools out of area while positioning yoke.

- 3) Position ON LINE/LOCAL switch to LOCAL.
- 4) Position TEST/NORMAL switch to NORMAL.
- 5) Press MASTER RESET (rear panel pushbutton).
- 6) Enter full display of H characters by momentarily pressing the H character key while pressing REPEAT key. Hold REPEAT key down. If unable to create H character display, proceed to sheet 1 of table CRT1, DDLT for Display Terminal.
- 7) Check if full display of H characters is tilted on screen. If tilted, do steps 8, 9, and 10. If not, do centering check of step 11.
- 8) Turn power off and loosen clamp screw (nearest crt) which holds yoke in position on neck of crt.
- 9) Turn power on. Enter a full display of H characters.
- 10) Rotate yoke both ways until the display characters are not tilted.
- 11) Check if full display of H characters is centered correctly on screen. If display is centered, go directly to step 12. If not, adjust centering tabs on yoke until display is centered (figure CRT19). Initial setting of the centering tabs should be 180° apart.
- 12) Observe the H characters on the screen. Are H characters in leftmost column and rightmost column of sufficient vertical height (similar to H characters in center of screen)? If not, adjust the vertical linearity potentiometer (figure CRT20). Are H characters on left side of screen distorted while right side is not? If so, adjust horizontal linearity sleeve per step 13.

- 13) Check that shielding sleeve on neck of crt is in place approximately as shown in figure CRT19. If shielding sleeve is not correctly positioned, left side of screen will be distorted while right side is not, or right side of screen is distorted while left is not. Pushing shielding sleeve toward the yoke has the effect of distorting left portion of screen; if pushed too far forward, the left-half of screen is blacked out.

NOTE

Horizontal linearity sleeve adjustment affects the horizontal width. Refer to size adjustments of procedure CRT26 and repeat the horizontal linearity and horizontal size adjustments in iterative fashion.

- 14) After yoke and shielding sleeve are correctly adjusted, and crt ground clip is under sleeve, carefully, without using force, tighten clamp screws on yoke and focus assemblies until clamps are snug.
- 15) Perform monitor adjustments (procedure CRT26).

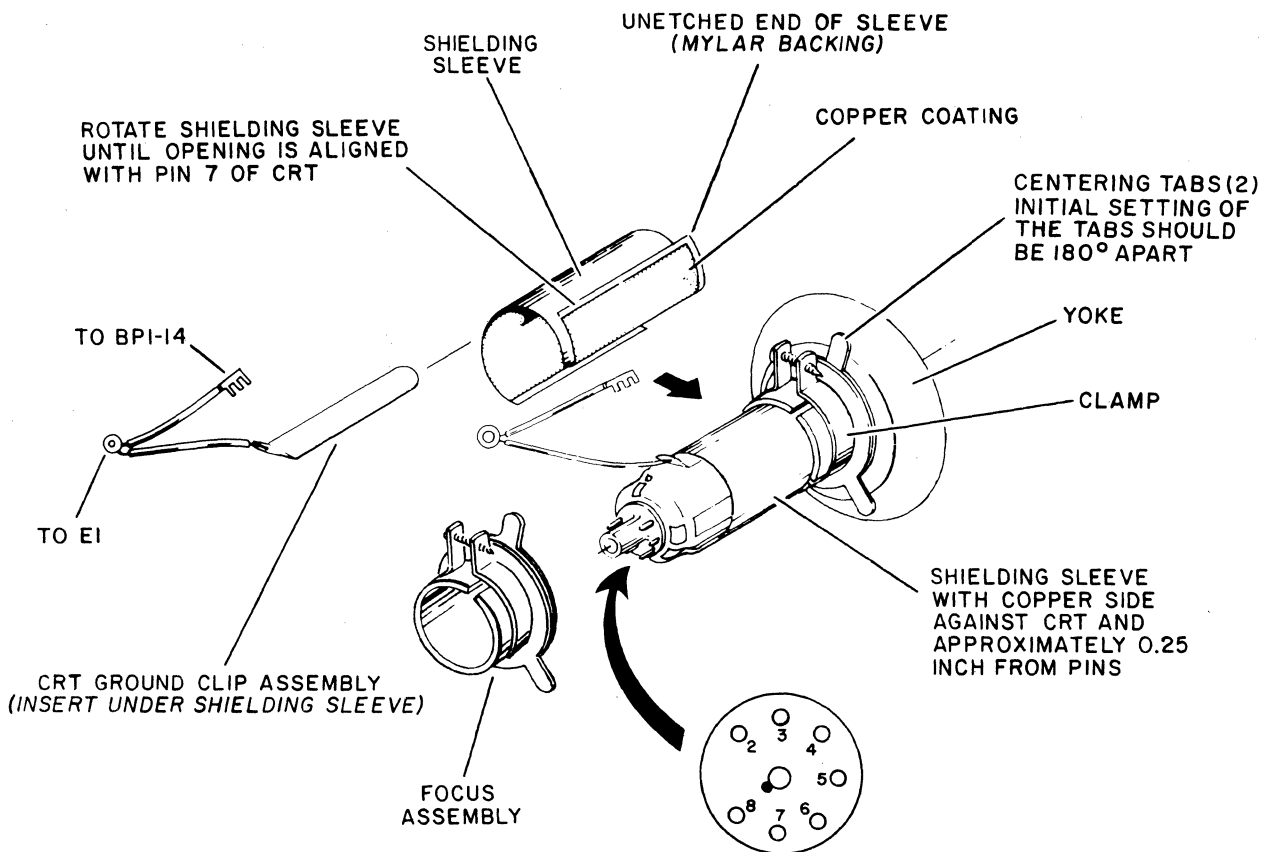

01961-5

Figure CRT19. Shielding Sleeve Positioning

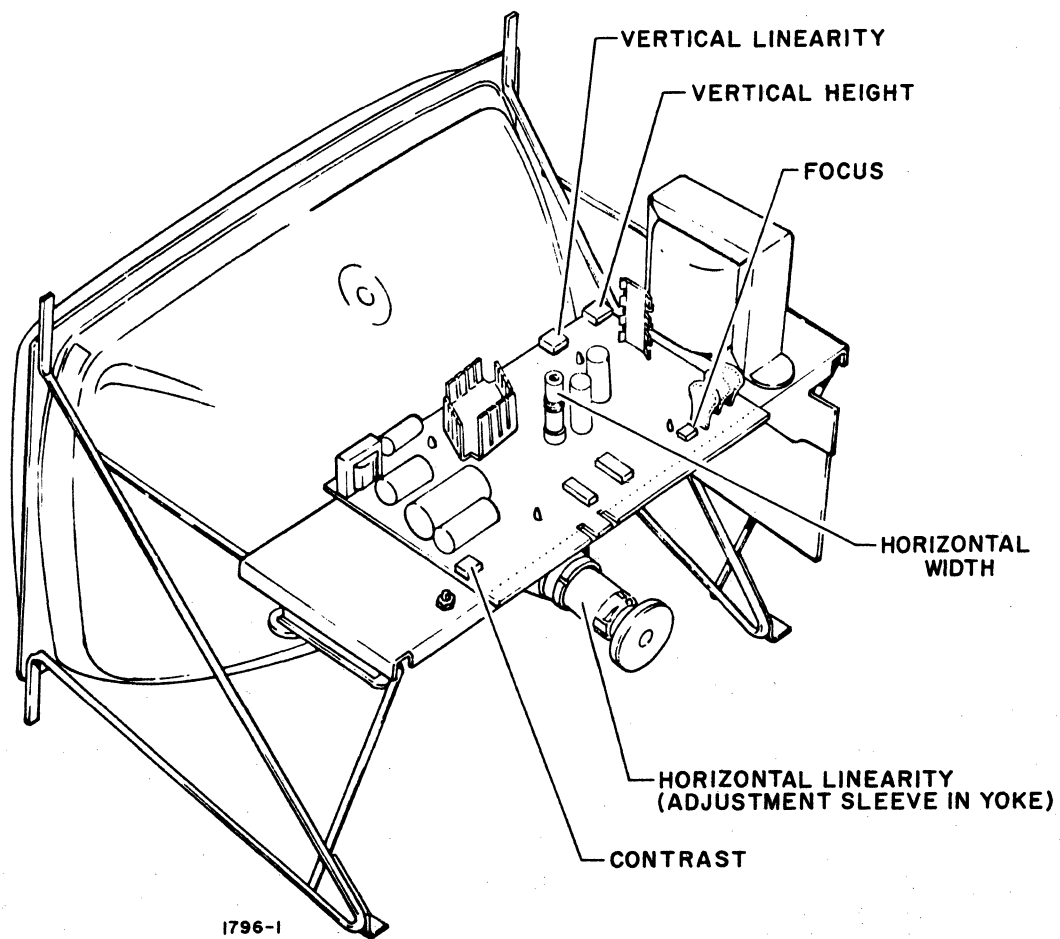

Figure CRT20. Focus, Contrast, and Vertical Linearity

Procedure CRT15 — Replacing Yoke on Display Terminal CRT

To remove yoke from neck of crt, perform the following:

- 1) Press POWER ON/OFF switch to OFF.
- 2) Disconnect ac power cord from site power outlet.

WARNING

Use extreme care when handling the TV module because rough handling can cause the crt to implode with tremendous force resulting in severe injury. Do not nick or scratch glass or subject it to any undue pressure during replacement. When handling crt, always wear safety goggles and heavy gloves for protection.

- 3) Connect heavily insulated wire to ground first and then, while carefully lifting rubber anode cover, discharge surface under rubber cover (including anode terminal end) by sliding end of grounded wire under rubber cover and into anode hole of cathode-ray tube.
- 4) Disconnect crt ground clip ring lug from E1.*
- 5) Pull connector BP4 off edge of video printed-circuit board. Connector BP4 is largest connector with wires leading to yoke.
- 6) Disconnect flag terminals 9, 10, 18, and 19 from BP4 connector (four wires leading to yoke) by inserting small end of paper clip into top of connector in space available between flag terminal and insulation (see figure CRT21) and then pulling out wire gently from bottom of connector. (Flag terminal end has a wedge-type spring clip which, when released by paper clip, permits flag terminal to be withdrawn with wire from connector.)

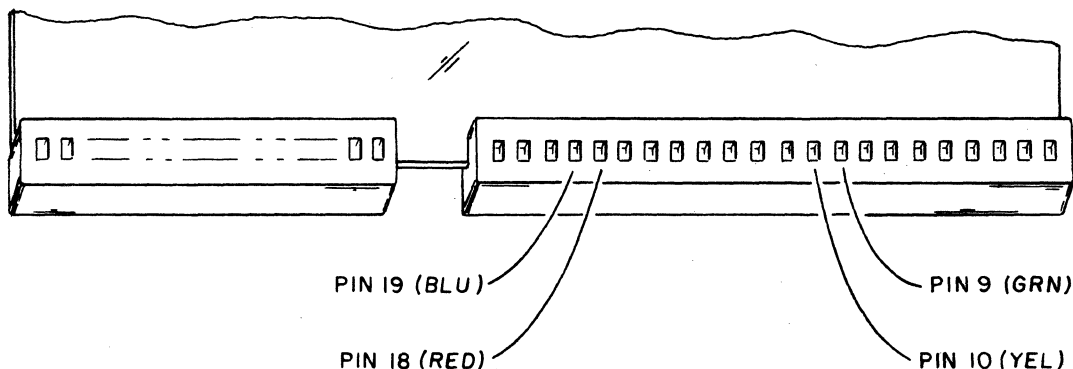

Figure CRT21. Removing Flag Terminals

* Disregard step if assembly is not used on unit.

- 6) Pull crt tube socket carefully off end of crt (figure CRT22). Do not remove vinyl keyguide.

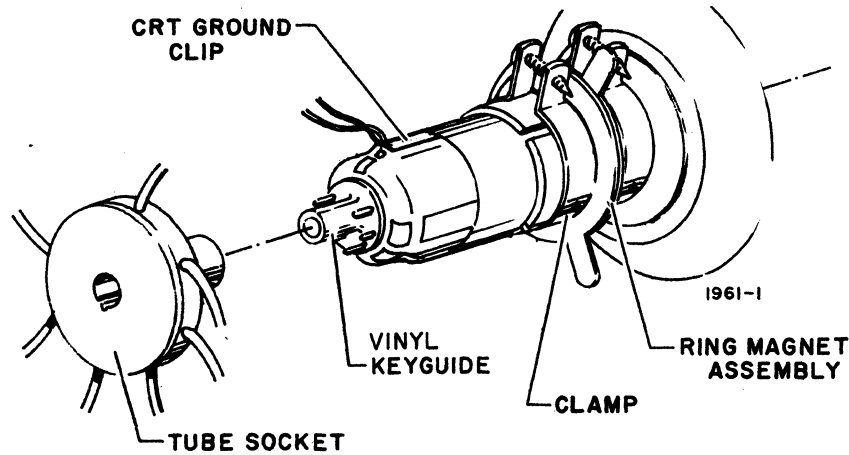

Figure CRT22. CRT Tube Socket Removal

- 7) Loosen ring magnet assembly mounting clamp, remove crt ground clip and ring magnet assemblies (figure CRT22).*
- 8) Loosen clamp which holds yoke in place with screwdriver (figure CRT23).
- 9) After screw is loosened, gently slide yoke shielding sleeve, which is between crt neck and yoke, back on crt neck until yoke can be removed from device.

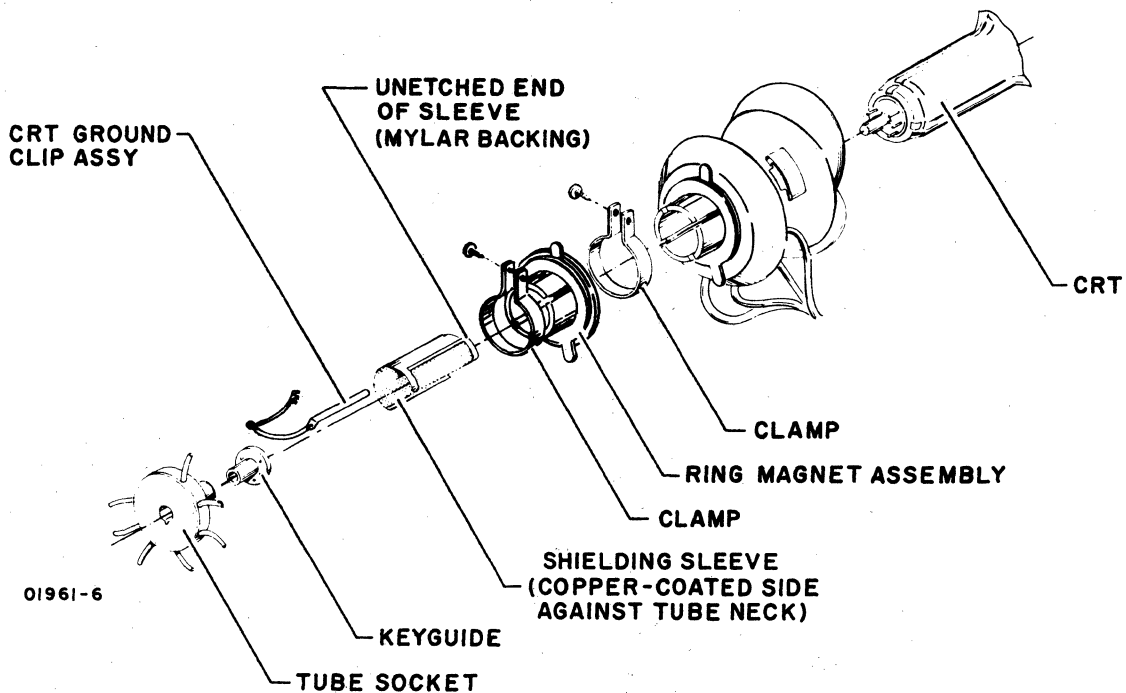

Figure CRT23. Yoke Assembly

* Disregard step if assemblies are not used on unit.

To install yoke, perform the following:

- 10) Position sleeve approximately as shown in figure CRT24, but with opening straight down and aligned with pin 7 of crt tube socket.
- 11) Position yoke over sleeve with wires downward (figure CRT23). The red and green wires should be on the left and the yellow and blue on the right as viewed from rear of crt.

WARNING

Never tighten clamp which holds yoke on neck of crt more than enough to hold yoke in place. If tightened excessively, it is possible to break neck of crt. Wear protective goggles and heavy gloves for protection.

- 12) Position clamp over end tabs of yoke and tighten slightly.
- 13) Butt ring magnet assembly up against yoke. Insert crt ground clip assembly (back of ring magnet assembly) between shielding sleeve and neck of crt. Tighten clamp on ring magnet assembly slightly.
- 14) Plug crt tube socket carefully on pins of crt, making sure guide matches slot in socket.
- 15) Insert flag terminals into BP4 connector:
 - a) Push green wire terminal into slot (pin location 9) until wedge-like clip locks itself in place.
 - b) Push yellow wire into slot 10.
 - c) Push red wire into slot 18.
 - d) Push blue wire into slot 19.

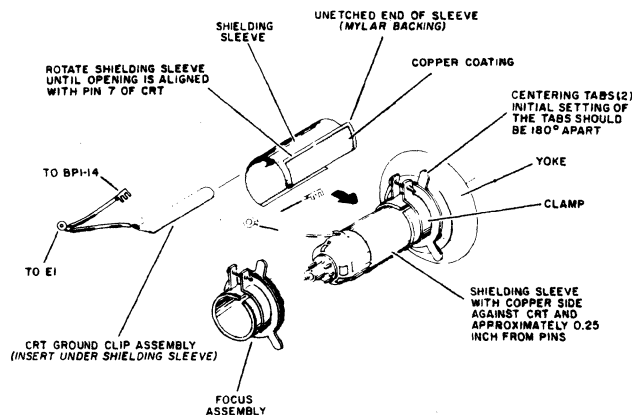

Figure CRT24. Positioning Shielding Sleeve

- 16) Plug BP4 connector onto edge of video printed-circuit board and reconnect ground wire from crt ground clip assembly to E1.
- 17) Place rear panel circuit breaker in down position and plug ac power cord into site power outlet.
- 18) Place circuit breaker on rear panel in up position.
- 19) Press POWER ON/OFF switch to ON.
- 20) Check that TEST/NORMAL switch is in NORMAL position on rear panel.
- 21) Check that ON LINE/LOCAL switch is at LOCAL position.
- 22) Wait 30 seconds
- 23) Cursor should appear in lower-left portion of display (unless scroll switch on memory board 08, as shown in figure CRT55, is disabled and CHARACTER/LINE/BLOCK switch on front panel is in BLOCK position — in this case, cursor should appear in upper-left portion of display). If cursor does not appear in either position, go to sheet 1 of table CRT1, DDLT for Display Terminal. After cursor appears, go to step 24.
- 24) Press REPEAT key after cursor appears.
- 25) Press H character key momentarily while holding REPEAT key down, and fill entire screen with H characters.
- 26) Release REPEAT key after screen is full.
- 27) If display is tilted, left or right side of screen is distorted, or raster is not centered on screen, perform horizontal and vertical alignment (procedure CRT14).

WARNING

Do not overtighten clamp on crt.

- 28) Tighten screw on crt clamp so yoke cannot move. Tighten ring magnet assembly clamp.

Procedure CRT16 — Replacing Display Terminal Vertical Choke

To replace vertical choke (figure CRT25), perform the following:

- 1) Press POWER ON/OFF switch to OFF.
- 2) Disconnect BP4 (longest) connector on video printed-circuit board. BP4 connector is on printed-circuit board next to vertical choke and has two flag terminals (pins 6 and 7) attached to wires leading to vertical choke.
- 3) Remove flag terminals 6 and 7 by inserting end of a small paper clip in space provided between installed flag terminal and connector insulation. Paper clip releases wedge-like friction lock on terminal and permits entire terminal to be removed out from bottom of connector.
- 4) Remove two hex nuts holding vertical choke to chassis.
- 5) Lift grounding wire from rear mounting screw, but do not remove from printed-circuit board.
- 6) Lift vertical choke from chassis.
- 7) Position new choke in place over two mounting screws so two wires are on side nearest printed-circuit board.
- 8) Connect grounding wire to rear mounting screw and fasten with hex nut.
- 9) Fasten other hex nut to front screw.
- 10) Insert flag terminals into slots 6 and 7 of BP4 connector until wires are locked and secured.
- 11) Connect BP4 connector to video printed-circuit board.
- 12) Press POWER ON/OFF switch to ON.
- 13) Go to sheet 1 of table CRT1, DDLT for Display Terminal.

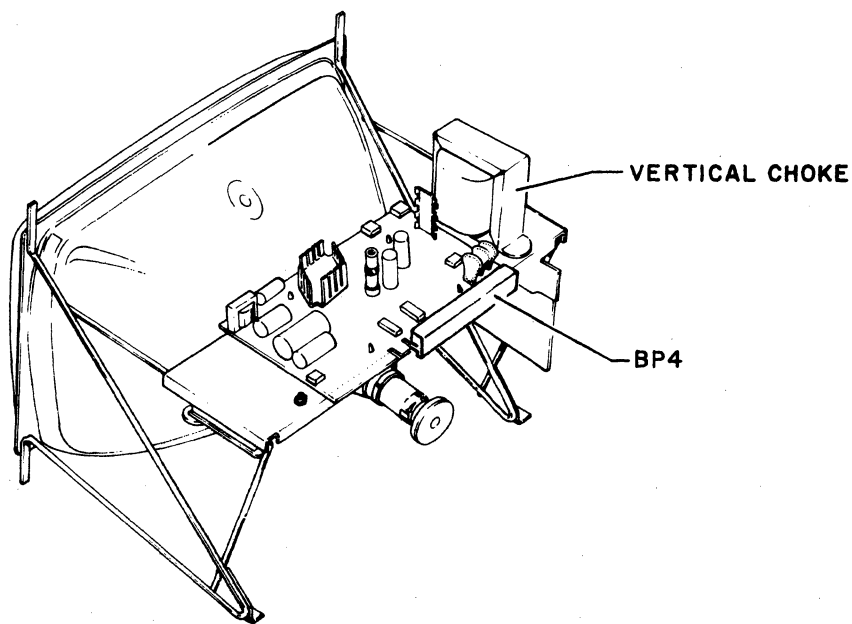

1796-1

Figure CRT25. Vertical Choke

Procedure CRT17 — Replacing Display Terminal Bulk Power Supply Board

To replace bulk power supply board, perform the following:

- 1) Press POWER ON/OFF switch to OFF.
- 2) Disconnect ac power cord from site power outlet.
- 3) Remove cabinet hood by removing two screws in rear of cabinet.
- 4) Remove video module (procedure CRT12, steps 1 through 6).
- 5) Disconnect J1 and J3 connectors (figure CRT26) from bulk power supply board.
- 6) Disconnect the two red wires leading from power transformer to CR4 mounted on heat sink.
- 7) Disconnect P1 from locations +V and -V on CR4.

- 7) Remove four hex screws holding board to chassis at corners of board.
- 8) Lift entire assembly out of chassis.
- 9) Place new board on mounting pegs and fasten with four mounting hex screws.
- 10) Plug J1 and J3 connectors into sockets (figure CRT26).
- 11) Connect the two red wires from the power transformer to the ac terminal pins of CR4.
- 12) Verify that +V (red) and -V (blue) wires are connected to J2 (figure CRT26).
- 13) Replace video module (procedure CRT12).
- 14) Connect ac power cord to site power outlet, press POWER ON/OFF to ON, and go to sheet 1 of table CRT1, DDLT for Display Terminal.

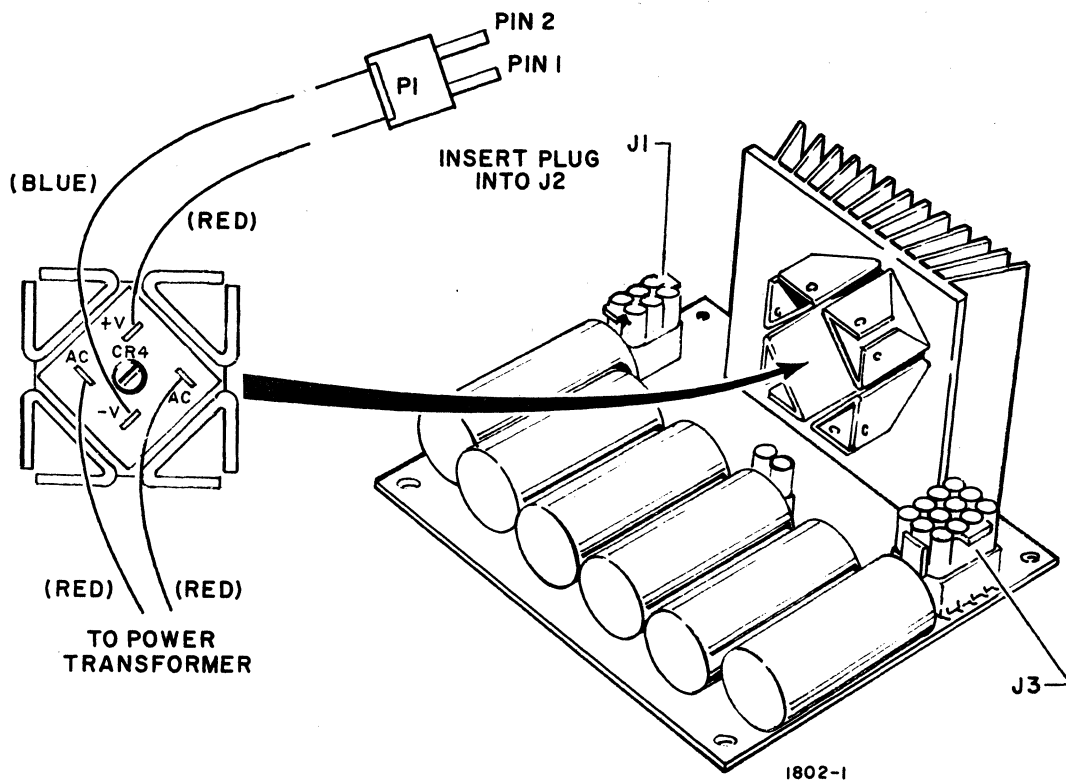

Figure CRT26. Bulk Power Supply Board

Procedure CRT18 — Replacing Keyboard

To replace keyboard, perform the following:

- 1) Press POWER ON/OFF switch to OFF.
- 2) If display keyboard is attached to main chassis, lift chassis sufficiently to slide keyboard out of attached position.

CAUTION

If it is necessary to remove keyboard by lifting up main chassis, be careful not to allow chassis to fall backward.

- 3) Loosen two captive screws which hold keyboard data-entry-cable-connector in display chassis socket at lower-right-front side of display terminal chassis.
- 4) Disconnect keyboard assembly from terminal by gently pulling data entry cable out of display chassis socket.
- 5) Turn keyboard assembly over and remove six screws holding keyboard cover to keyboard chassis.
- 6) Return keyboard to keys-up position and lift cover off (figure CRT27).
- 7) Remove cable connector from edge of printed-circuit board.
- 8) Remove two screws which hold printed-circuit board and mask to chassis on one end, loosen other two on other slotted end, and lift out printed-circuit board.
- 9) Install new keyboard by sliding keyboard under two screws still in chassis and position properly over the other two mounting screw holes.
- 10) Insert and fasten four screws to secure PC board and mask to chassis.
- 11) Attach connector to printed-circuit board.
- 12) Place cover over assembly positioning keyboard so that keys don't bind on cover. If binding exists, loosen the four screws of step 10 and adjust positioning.

- 13) Holding cover in place, turn assembly over and insert six screws into bottom of chassis.
- 14) Complete installing new keyboard by doing steps 2, 3, and 4 in reverse order and reverse action.

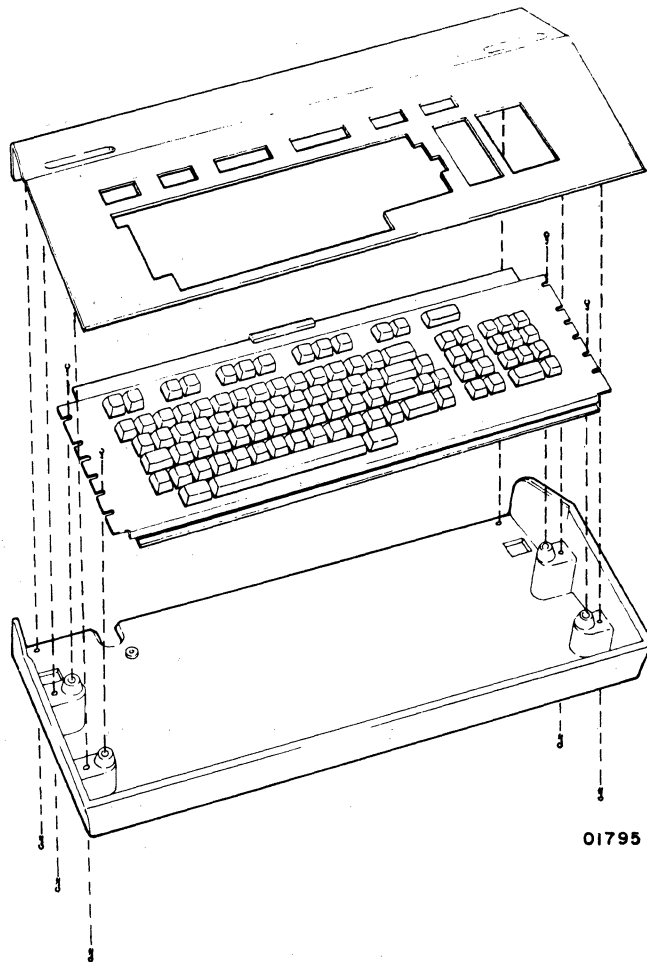

Figure CRT27. Keyboard Assembly

Procedure CRT19 — Replacing Display Terminal ac Entry Transformer

To replace ac entry transformer (figure CRT28), perform the following:

- 1) Turn power off (procedure CRT2) and disconnect ac power cord.
- 2) Remove cabinet hood by removing two screws at rear of cabinet and sliding cabinet to rear and up.

- 3) Remove video module (procedure CRT12, steps 1 through 6).
- 4) Disconnect connector at J1 of bulk power supply (figure CRT26).
- 5) Disconnect connector leading to ac entry panel (CP2).
- 6) Disconnect single quick-disconnect terminal (spade lug) at transformer. (Applicable to early versions only.)
- 7) Disconnect ground wire that goes to E2 of ac entry panel. (Applicable to latest versions.)
- 8) Disconnect two red wires from transformer connected to ac terminal of CR4 on bulk power supply board.
- 9) Remove four screws which hold transformer to bottom of chassis.
- 10) Lift transformer out of chassis.
- 11) Place new transformer into position vacated by old one.
- 12) Fasten down transformer with four screws.
- 13) Connect single quick-disconnect terminal at transformer. (Applicable to early versions only.)
- 14) Connect ground wire to E2 and connect two red wires to CR4. (Applicable to latest versions.)
- 15) Connect J1 connector to bulk power supply board.
- 16) Connect connector CP2 leading to ac entry panel.
- 17) Replace video module (procedure CRT12).
- 18) Connect ac power cord to site power outlet, press POWER ON/OFF switch to ON, and go to sheet 1 of table CRT1, DDLT for Display Terminal.

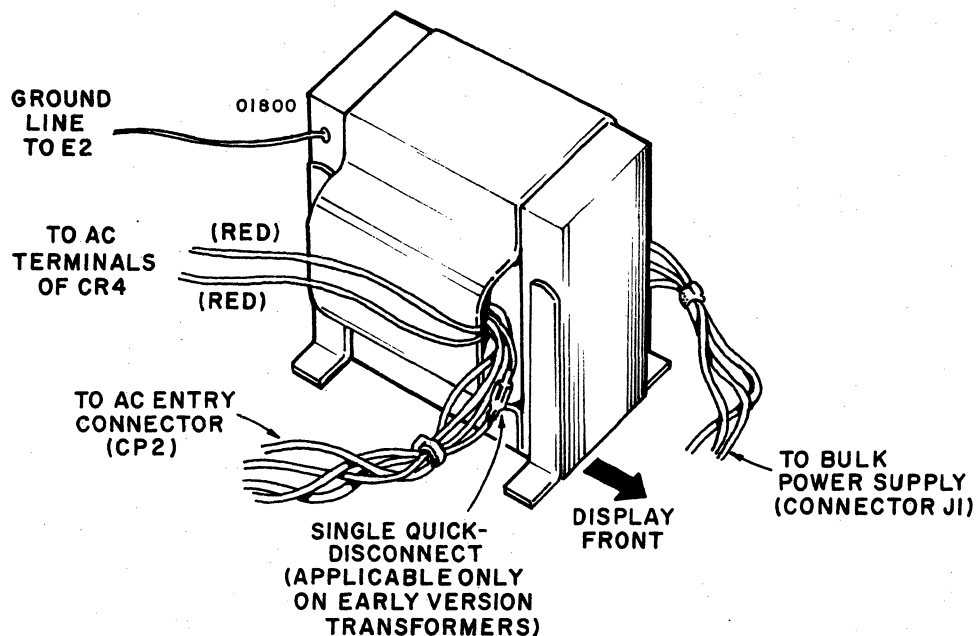

Figure CRT28. AC Entry Transformer

Procedure CRT20 — Measuring Voltages at Video Printed-Circuit Board

Use this procedure to measure +465-V dc, -190-V dc, +45-V dc, +15-V dc, and +5-V dc which should be present on the video printed-circuit board.

To measure +465-V dc, perform the following:

- 1) Set voltmeter to measure +465-V dc.
- 2) Remove cabinet hood (procedure CRT21).
- 3) Press POWER ON/OFF to ON.
- 4) Connect black (-) lead from voltmeter to chassis ground.

WARNING

Do not touch anything with hands and use only one hand at a time to connect leads to test points.

- 5) Connect red (+) lead to resistor R8A (figure CRT29).
- 6) Check that voltmeter indicates +465-V dc ± 47 -V dc. If within tolerance, go to step 7; if not, go to sheet 8 of table CRT1, DDLT for Display Terminal.

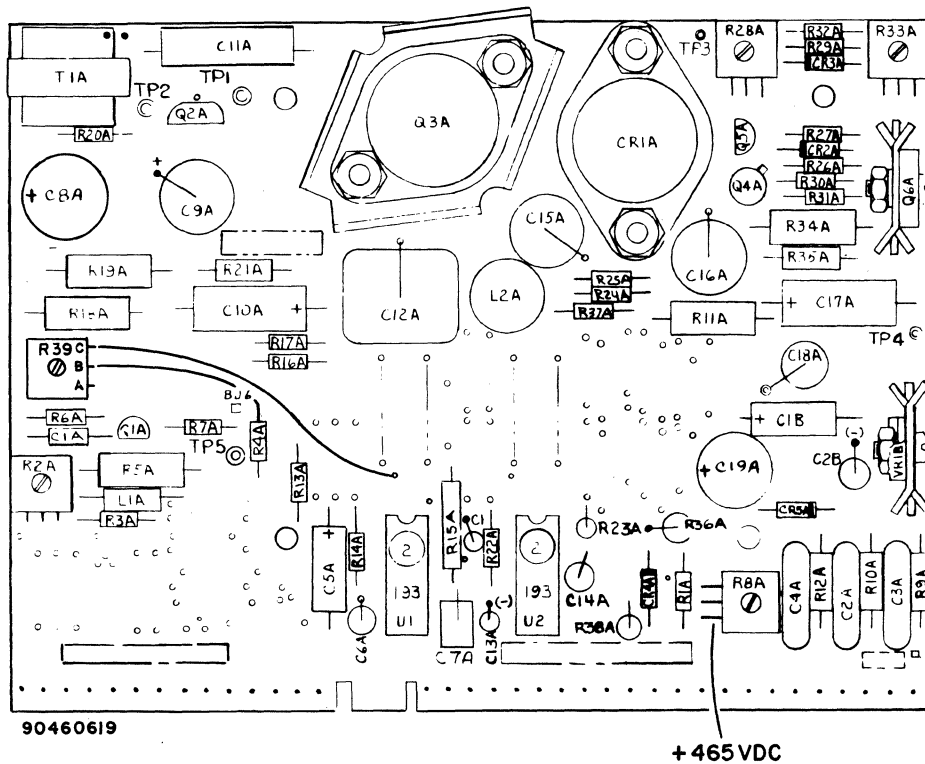

Figure CRT29. Test Point for +465-V dc

To measure -190-V dc, perform the following:

- 7) Set voltmeter to measure -190-V dc.
- 8) Connect positive (+) lead to chassis ground. If voltmeter has separate switch for selecting -dc, reverse polarity, such as Simpson Model 250, connect common (black lead) to chassis ground and select -dc on meter.
- 9) Connect negative (-) lead to R1A (figure CRT30).
- 10) Check that voltmeter indicates -190-V dc ± 25 -V dc. If reading is within tolerance, go to step 11; otherwise, go to sheet 8 of table CRT1, DDLT for Display Terminal.

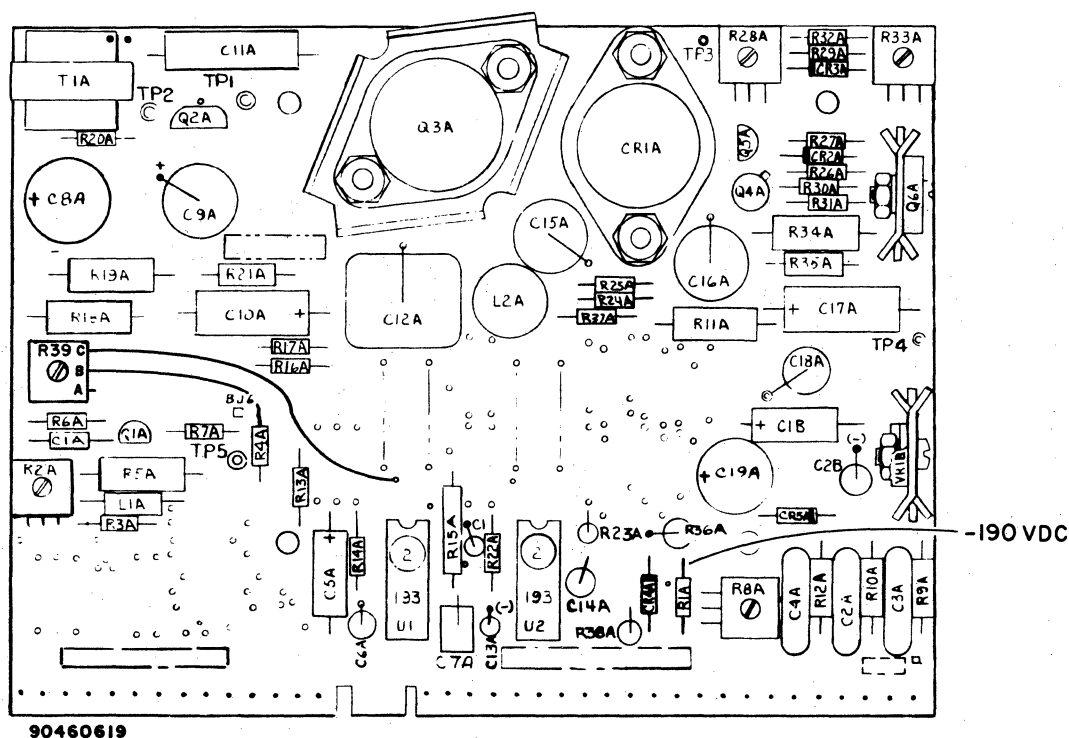

Figure CRT30. Test Point for -190-V dc

To measure +45-V dc, perform the following:

- 11) Set voltmeter to measure +45-V dc.
- 12) Connect black lead to chassis ground.
- 13) Connect red (+) lead to diode CR4A (figure CRT31).
- 14) Check that meter indicates +45-V dc ± 4.5 -V dc. If within tolerance, go to step 15; if not, go to sheet 8 of table CRT1, DDLT for Display Terminal.

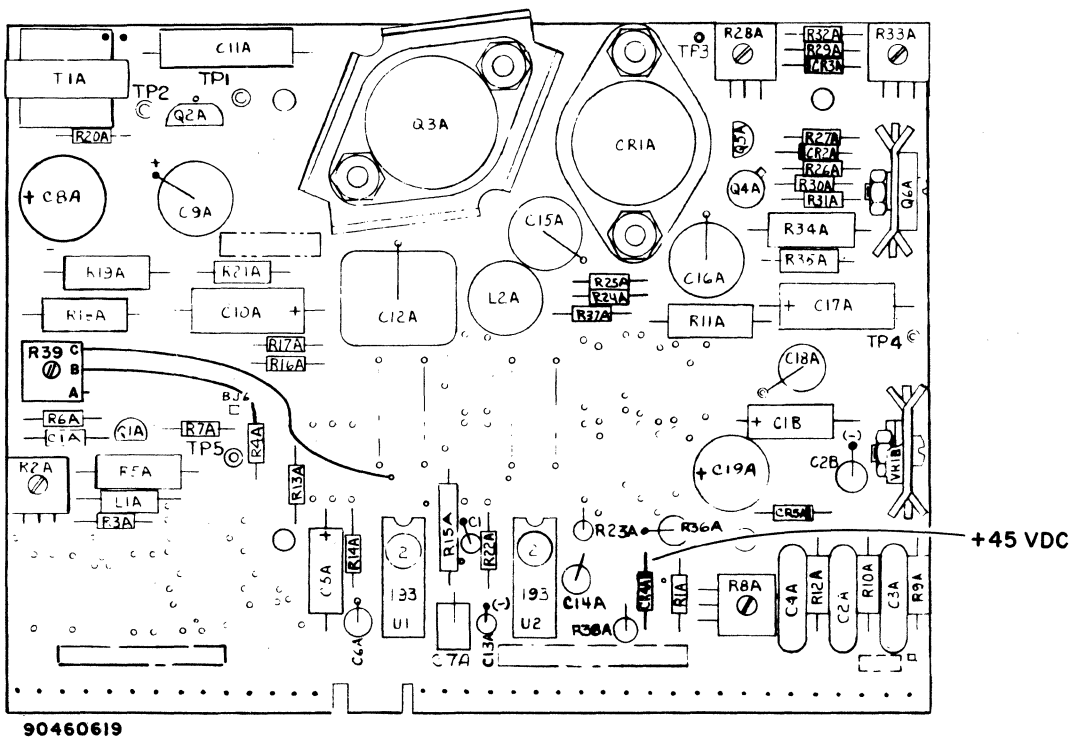

Figure CRT31. Test Point for +45-V dc

To measure +5-V dc and +15-V dc, perform the following:

- 15) Set voltmeter to measure +15-V dc.
- 16) Connect black (-) lead to chassis ground.
- 17) Connect red (+) lead to pin 8 of BJ4 (figure CRT32).
- 18) Check that meter indicates +15-V dc ± 0.75 -V dc.
- 19) Connect red (+) lead to pin 22 of BJ4.
- 20) Check that meter indicates +15-V dc ± 0.75 -V dc.
- 21) Connect red (+) lead to pin 16 of either IC as shown in figure CRT32.
- 22) Check that meter indicates +5-V dc ± 0.25 -V dc.
- 23) Go to sheet 8 of table CRT1, DDLT for Display Terminal.

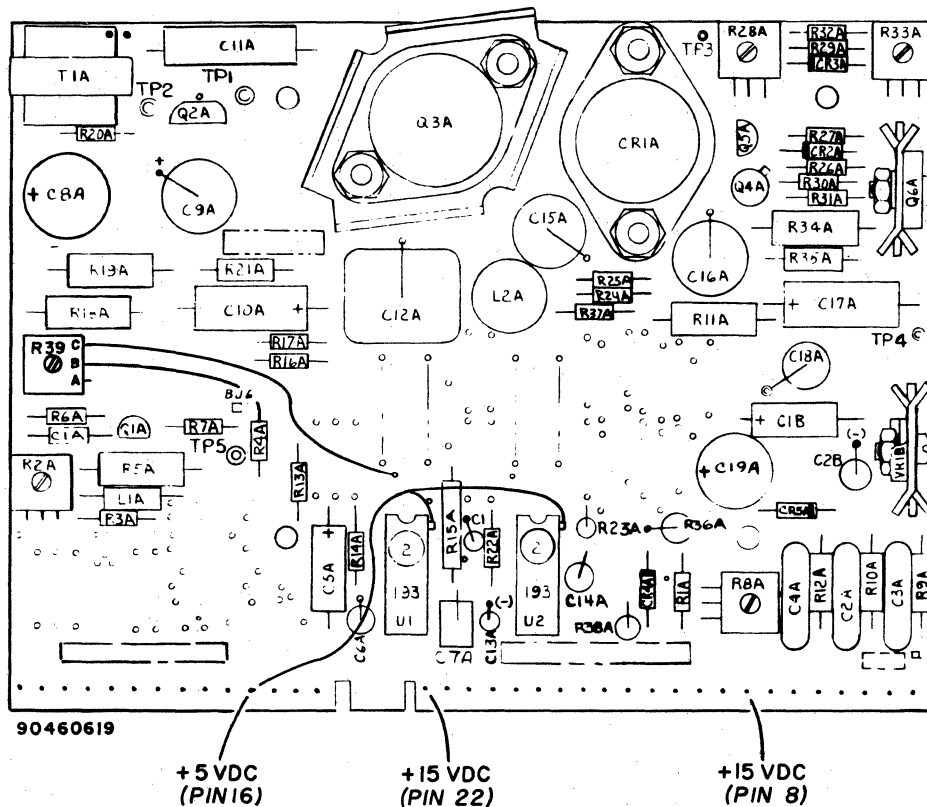

Figure CRT32. Test Pins for +5 and +15-Vdc

Procedure CRT21 — Removing Display Terminal Cabinet Hood

To remove cabinet hood, perform the following:

WARNING

Use extreme care when handling the TV module because rough handling can cause the crt to implode with tremendous force resulting in severe injury. Do not nick or scratch glass or subject it to any undue pressure during replacement. When handling crt, always wear safety goggles and heavy gloves for protection.

WARNING

With power applied, severe shock will be received if high-voltage transformer or lead to anode or area of anode on crt is touched. Be careful when following procedures are performed not to touch anything higher than yoke. Keep tools out of area.

- 1) Remove two screws in rear of cabinet.
- 2) Lift cabinet hood back and up from chassis.

To install cabinet hood, perform the following:

- 3) Position cabinet hood in track of chassis.
- 4) Fasten two screws in rear of cabinet.

Procedure CRT22 — Measuring Low Voltages

Follow this procedure to measure low voltages (+5-V dc, +12-V dc, -12-V dc, -9-V dc, -23-V dc, +23-V dc, and -5-V dc) within the logic module.

To measure +5-V dc, perform the following:

- 1) Press POWER ON/OFF switch OFF.
- 2) Remove cabinet hood (procedure CRT21).
- 3) Press POWER ON/OFF switch ON.
- 4) Check for power-on condition (illuminated LED's) on board A03 in logic card cage. If no LED is illuminated, check that ac power cord is plugged into site ac power outlet. If still unable to get indicators to light, proceed to sheet 1 of table CRT1, DDLT for Display Terminal.
- 5) Set voltmeter to measure +5-V dc.
- 6) Apply voltmeter black (-) lead to ground (GND) test point on A03 board (figure CRT33).
- 7) Apply red (+) lead to +5-V dc test point (figure CRT33).
- 8) Check that meter indicates +5-V dc. If voltage is other than +5-V dc ± 0.25 -V dc, adjust to +5 by turning adjustment screw of potentiometer R12 (figure CRT33). If unable to adjust, replace A03 card.

NOTE

Only potentiometer R12, which faces rear of device (and can be adjusted while card is installed), is adjustable in the field. Do not adjust any other potentiometer on +5-V dc regulator board.

To measure +24-V dc, perform the following:

- 9) Set meter to measure +24-V dc.
- 10) Apply red (+) lead to +24-V dc test point (figure CRT33) and black (-) lead to GND (figure CRT33).
- 11) Check that meter indicates +24-V dc. If measurable voltage is less than +17-V dc or more than +30-V dc, replace bulk power supply board (procedure CRT17).

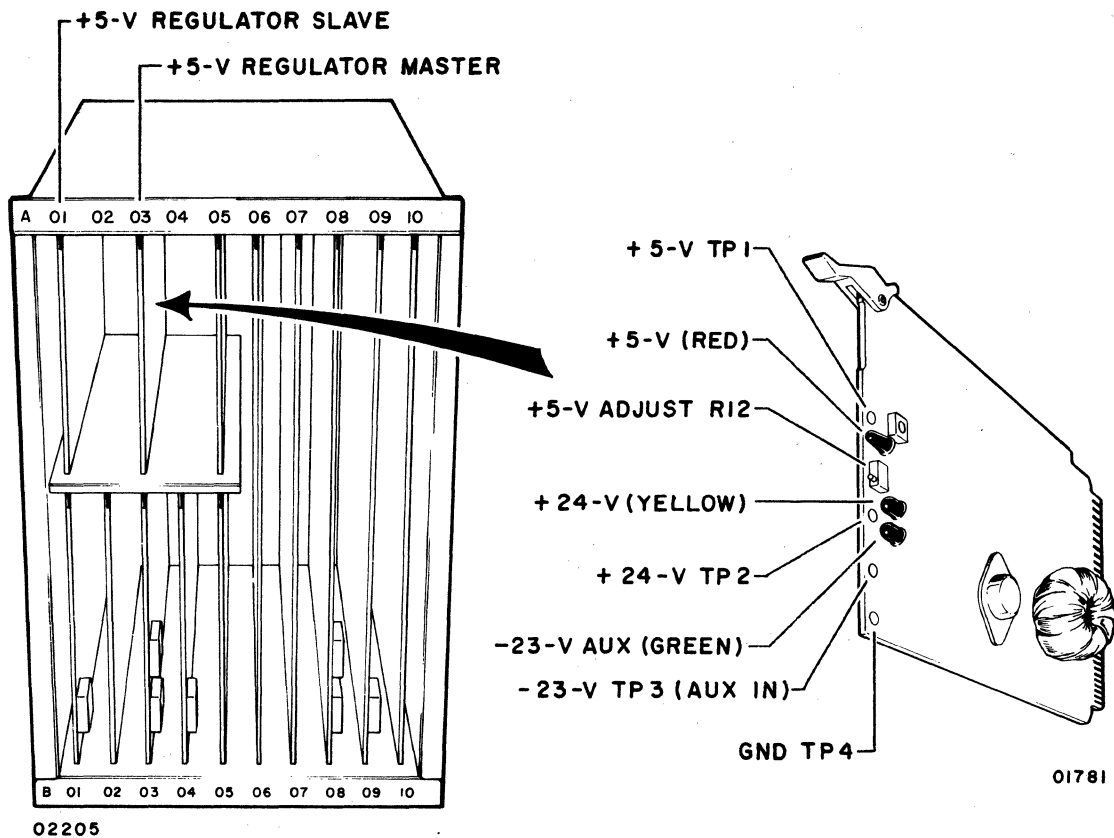

Figure CRT33. +5-V dc Regulator Board Test Points

To measure -23-V dc, perform the following:

- 12) Set meter to measure -23-V dc.
- 13) Apply black (-) lead to -23-V dc test point and red (+) lead to GND (figure CRT33).
- 14) Check meter for -23-V dc. If measurable voltage is outside the range of -17-V dc to -30-V dc, replace bulk power supply board (procedure CRT17).

To measure -9-V dc, perform the following:

- 15) Set meter to measure -9-V dc.
- 16) Apply red (+) lead to GND on board 08 (figure CRT34).
- 17) Apply black (-) lead to -9-V dc test point on board 08 (figure CRT34).
- 18) Check that meter indicates reading of -9-V dc ± 0.5 -V dc. If voltage reading falls outside indicated tolerance, replace bulk power supply board (procedure CRT17).

To measure -12-V dc, perform the following:

- 19) Set meter to measure -12-V dc.
- 20) Apply black (-) lead to -12-V dc test point on edge of board 09 (figure CRT34).
- 21) Apply red (+) lead to GND on board 09 (figure CRT34).
- 22) Check that meter indicates reading of -12-V dc ± 0.6 -V dc. If voltage is not within tolerance, replace bulk power supply board (procedure CRT17).

To measure +12-V dc, perform the following:

- 23) Set meter to measure +12-V dc.
- 24) Apply red lead to +12 test point on edge of board 09 just below test point 24 (figure CRT34).
- 25) Apply black (-) lead to GND on board 09 (figure CRT34).
- 26) Check that meter indicates reading of +12-V dc ± 0.6 -V dc. If voltage reading falls outside acceptable tolerance, replace bulk power supply board (procedure 17).

To measure -5-V dc, perform the following:

- 27) Set meter to measure -5-V dc.
- 28) Apply black (-) lead to -5-V dc test point on edge of board 09 (figure CRT34).
- 29) Apply red (+) lead to GND on board 09 (figure CRT34).
- 30) Check that meter indicates reading of -5-V dc ± 0.25 -V dc. If voltage reading falls outside indicated tolerance, check -9-V dc (steps 15 through 18). If -9-V dc check is within tolerance, and -5-V dc is not, replace processor board (procedure CRT8) which carries -5V regulator.

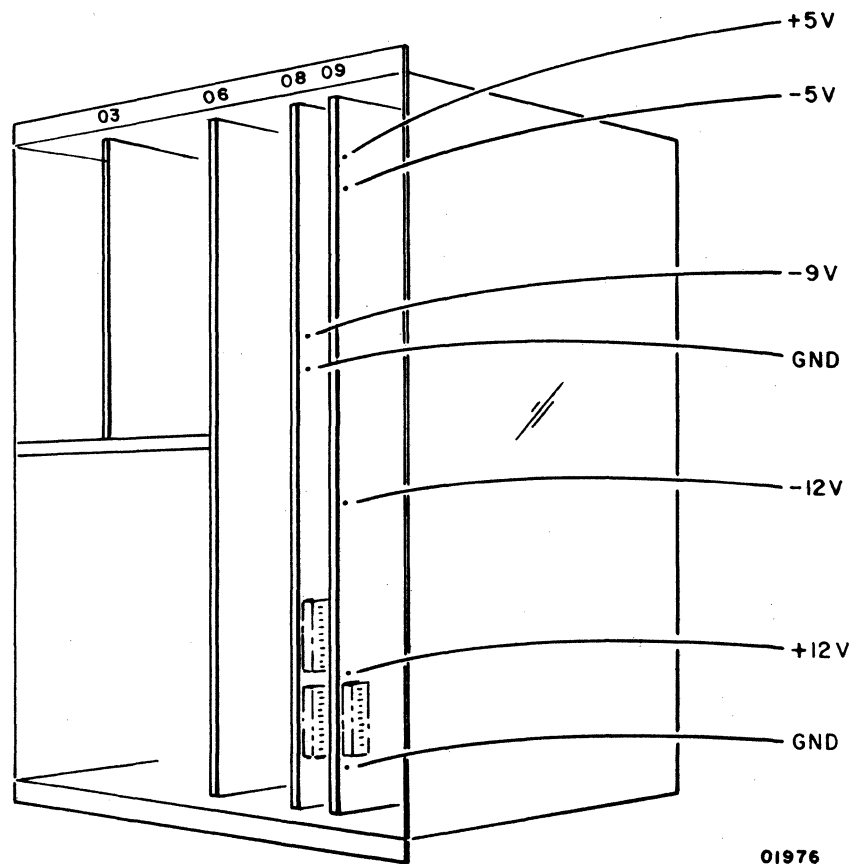

Figure CRT34. Memory and Processor Voltage Test Points

Procedure CRT23 — Checking and Replacing INTENSITY Control on Display Panel

To check INTENSITY control (figure CRT35), perform the following:

- 1) Press POWER ON/OFF switch OFF.
- 2) Remove indicator panel on which control is mounted (figure CRT35) by inserting fingers between panel and bezel (CRT10). Carefully pry out panel gradually from one end and then the other to release clips holding panel to bezel.
- 3) Set ohmmeter to X 1000 setting.
- 4) Attach one ohmmeter lead to center pin on back of INTENSITY control and the other lead to one of the other two pins.
- 5) Rotate INTENSITY control knob while holding leads to pins. Check that meter reads 0 ohm when INTENSITY is fully turned in one position and 10,000 ohms when fully turned in the other position. Replace INTENSITY control if unable to obtain correct results (steps 8 through 14 describe replacement).
- 6) Remove lead on outer pin and attach it to pin or other side of center pin. Keep other lead on center pin.
- 7) Rotate INTENSITY control knob as described previously (step 5) and observe meter for same readings. If unable to obtain correct results, replace INTENSITY control.

To replace INTENSITY control, perform the following:

- 8) Test new control with ohmmeter (steps 3 through 7).
- 9) Unsolder three wires from old control. Identify wires.
- 10) Pull off knob to gain access to hex ringnut on front side of panel.
- 11) Remove hex ringnut using a 1/2-inch socket.
- 12) If applicable to unit, remove ground wire on inside of panel and withdraw old control from unit.

- 13) Solder three wires to new control and attach to panel by inserting control post through hole in panel, screwing on hex ringnut from the front, and tightening. If applicable to unit, before tightening nut fully, attach ground wire between control and panel.
- 14) Replace panel by inserting bottom edge in bezel opening and pressing panel into place carefully while aligning panel with hole and gently apply pressure down and in. Slight pressure on clips allows them to be inserted easily.

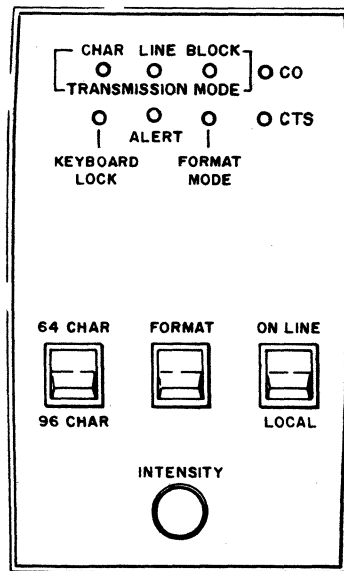

01696-1

Figure CRT35. INTENSITY Control

Procedure CRT24 — Checking and Replacing Baud Rate Switches

To check operation of baud rate switches, perform the following:

- 1) Press POWER ON/OFF switch to OFF.
- 2) Remove cabinet hood (procedure CRT21).
- 3) Note setting of baud rate switches on processor board 09 and check their positions with decal on side of card cage (figure CRT55) to verify that low baud rate switch setting is 110 baud (switches set = 1111 on board 09) and high baud rate switch setting is 9600 baud (switches set = 0110 on board 09). Figure CRT36 shows these two basic settings. If system requires any of the other available low and/or high baud rates, check switch settings per figures CRT37 and CRT38.

- 4) Press HIGH RATE/300/LOW RATE switch on front panel to LOW RATE.
- 5) Position TEST/NORMAL switch (ac power entry panel) to TEST.
- 6) Press POWER ON/OFF switch to ON.
- 7) Wait 30 seconds. If checksum pattern (figure CRT56) appears on top two display lines, proceed to step 8; otherwise, proceed to table CRT1 DDLT for Display Terminal, sheet 1.
- 8) Press space bar on keyboard twice.
- 9) Wait until terminal begins writing characters on screen at bottom line (may take 15 seconds for terminal to reach portion of memory that is displayed). Observe what should be the low rate (110 baud) characters being written on display.
- 10) Press HIGH RATE/300/LOW RATE switch on front panel to 300 while observing characters being written on screen. Rate of character writing on screen should more than double (from 110 baud to 300 baud).
- 11) Press HIGH RATE/300/LOW RATE switch of front panel to HIGH RATE while observing characters being written on screen. Rate of character writing on screen should increase by factor of 32 (from 300 baud to 9600 baud).
- 12) Replace processor board (procedure CRT8) if rate at which characters are written on screen does not speed up appropriately when rate switch is moved from LOW RATE to 300 or from 300 to HIGH RATE. If problem still exists, check HIGH RATE/300/LOW RATE switch (steps 13 through 18).

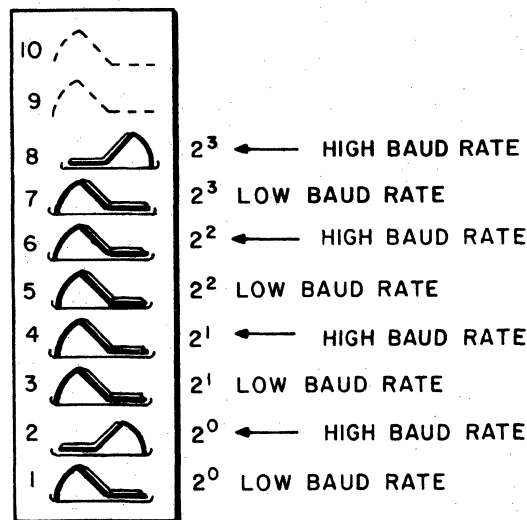

NOTE: SWITCHES INDICATED BY DOTTED LINES ARE USED FOR OTHER FUNCTIONS.

01968

Figure CRT36. High Baud Rate Set to 9600 — Low Baud Rate Set to 110

- 13) Press POWER ON/OFF to OFF.
- 14) Remove front switch-indicator panel by inserting fingers or knife between panel and bezel.
- 15) Check continuity between center black wire (pin S5-2) and top white/black wire (pin S5-1) with switch pressed to HIGH RATE (up) position. Ohmmeter or continuity tester should indicate no resistance (closed circuit).
- 16) Keep meter test leads on top and center pins and move switch to 300 (center) position and then to LOW RATE (bottom) position. Meter should indicate an open circuit in both positions.
- 17) Check continuity between center black wire (pin S5-2) and bottom white/orange wire (pin S5-3) with switch pressed to LOW RATE position. Meter should indicate a closed circuit (continuity). If circuit is open, replace switch (step 19, etc.).
- 18) With meter leads still attached to center pin and bottom pin, press switch to 300 (center) position and HIGH RATE (top) position. Meter should show an open circuit in both switch positions. If a closed circuit is indicated, replace switch (step 19, etc.).

BAUD RATE

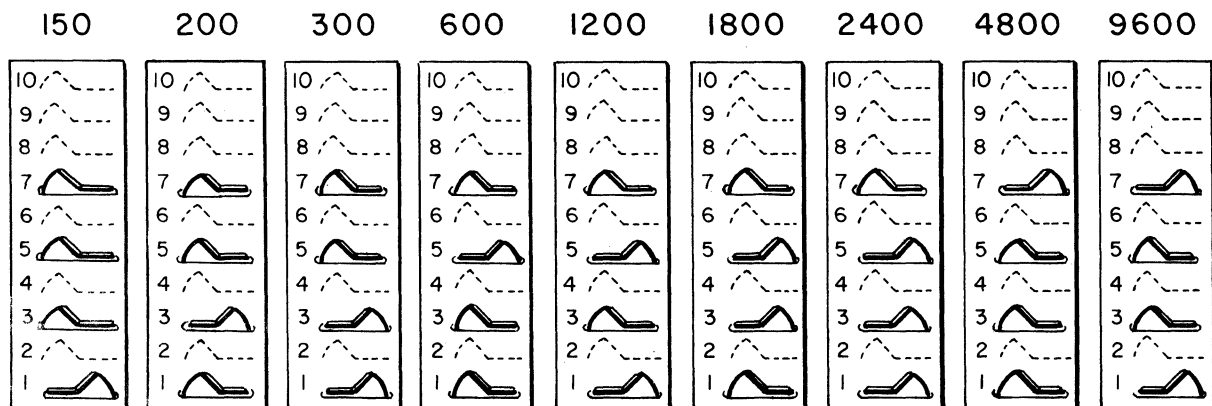

NOTE: SWITCHES INDICATED BY DOTTED LINES ARE USED FOR OTHER FUNCTIONS.

01969

Figure CRT37. Setting Low-Baud-Rate Switches

To remove HIGH RATE/300/LOW RATE switch, perform the following:

- 19) Press POWER ON/OFF switch to OFF.
- 20) If panel is not removed from bezel, insert fingers or knife between bezel and panel to remove.
- 21) Identify wires with masking tape: top white/black wire should be marked S5-1; center black wire should be marked S5-2; and bottom white/orange wire should be marked S5-3.
- 22) Slide wires from switch terminals.
- 23) Remove switch from panel by pushing it out from pin side of panel.

To install new switch, perform the following:

- 24) Insert switch into mounting hole in front of panel and press into place, making sure pins are oriented/offset same as other panel switches.
- 25) Slide wires on pins; S5-1 on top, S5-2 (black) in center, and S5-3 on bottom.
- 26) Position panel over mounting hole in chassis and press gently into bezel.

BAUD RATE

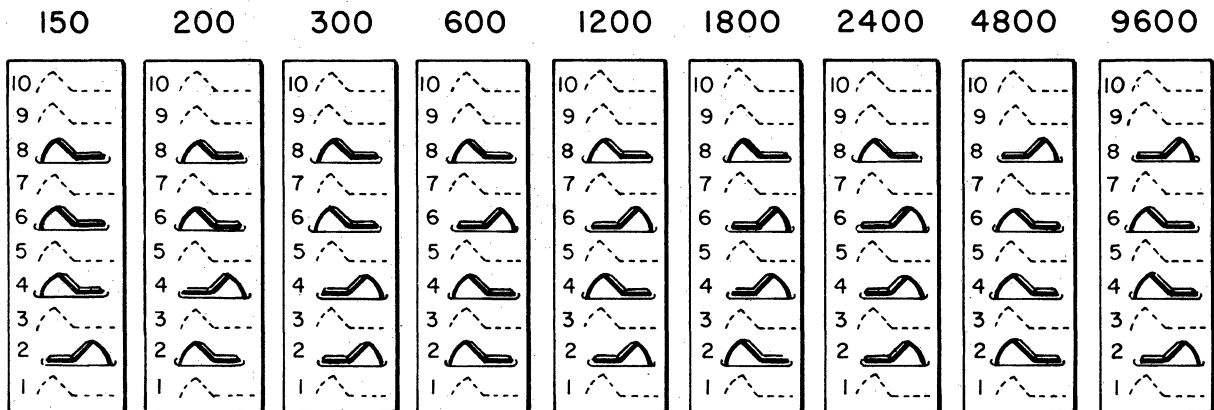

NOTE: SWITCHES INDICATED BY DOTTED LINES ARE USED FOR OTHER FUNCTIONS.

01970

Figure CRT38. Setting High-Baud-Rate Switches

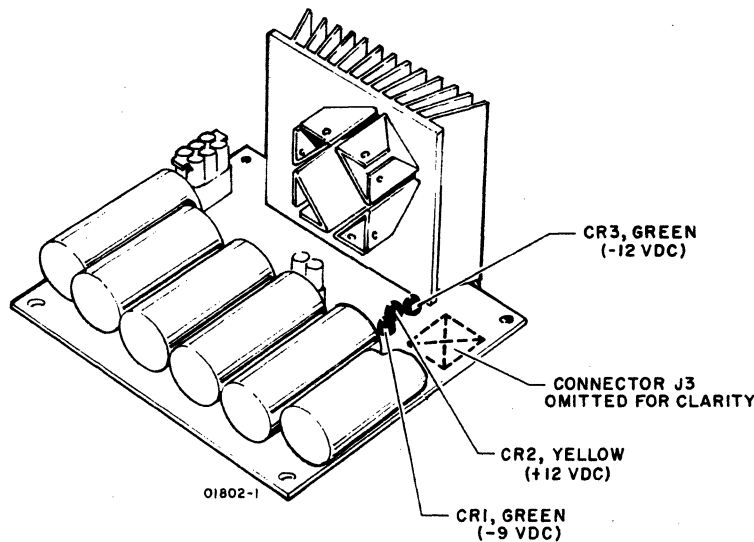

Figure CRT39. Bulk Power Supply Indicator Lights

Procedure CRT25 — Checking Keyboard

To check operation of keyboard, perform the following:

- 1) Check lowercase keys (96-character set).
 - a) Set 64 CHAR/96 CHAR switch to 96 CHAR (figure CRT40).
 - b) Release SHIFT LOCK key if locked.
 - c) Press each black key in turn (excluding REPEAT and CONTROL keys, but including space bar and numeric pad), examining display for proper character.

- 2) Check uppercase keys (96-character set).
 - a) While pressing either SHIFT key, press each black key in turn excluding REPEAT and CONTROL keys).
 - b) Repeat step a) using other SHIFT key (one key is sufficient).
 - c) Press SHIFT LOCK key.
 - d) Press one or two black keys, examining display for proper character.

- 3) Check CONTROL keyboard keys.
 - a) Release SHIFT LOCK key if locked.
 - b) While pressing either CONTROL key, press each of keys shown in figure CRT41, examining display for control code symbols (see Appendix for control code symbols repertoire).
 - c) Repeat step b) using other CONTROL key (one key is sufficient).

- 4) Check alpha keys (64-character set).
 - a) Set 64 CHAR/96 CHAR switch to 64 CHAR (figure CRT40).
 - b) Release SHIFT LOCK key if locked.
 - c) Press any alpha key, examining display for proper uppercase alpha character.
 - d) Return 64 CHAR/ 96 CHAR switch to normal operating position.

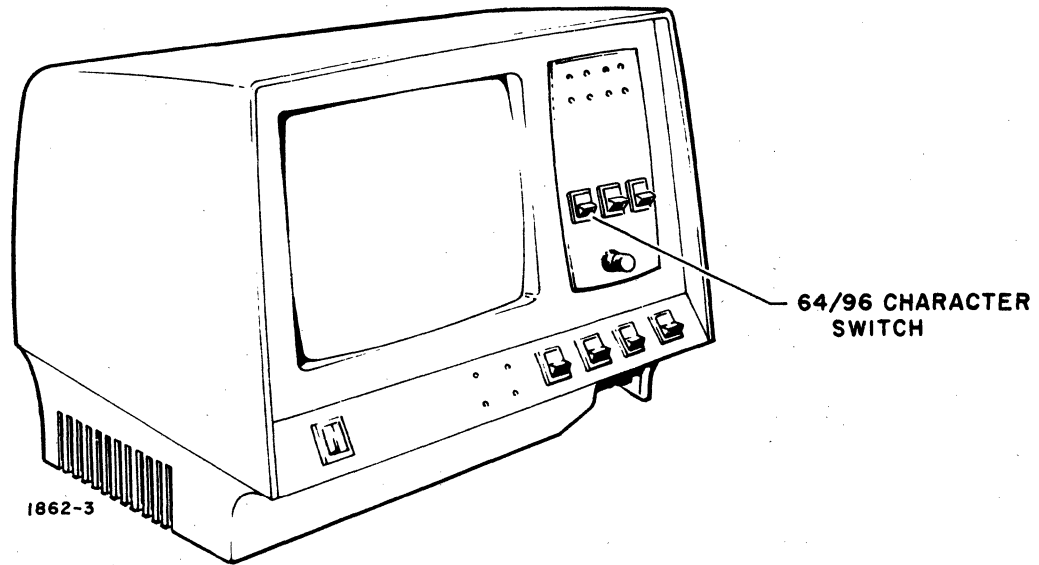

Figure CRT40. 64 CHAR/96 CHAR Switch

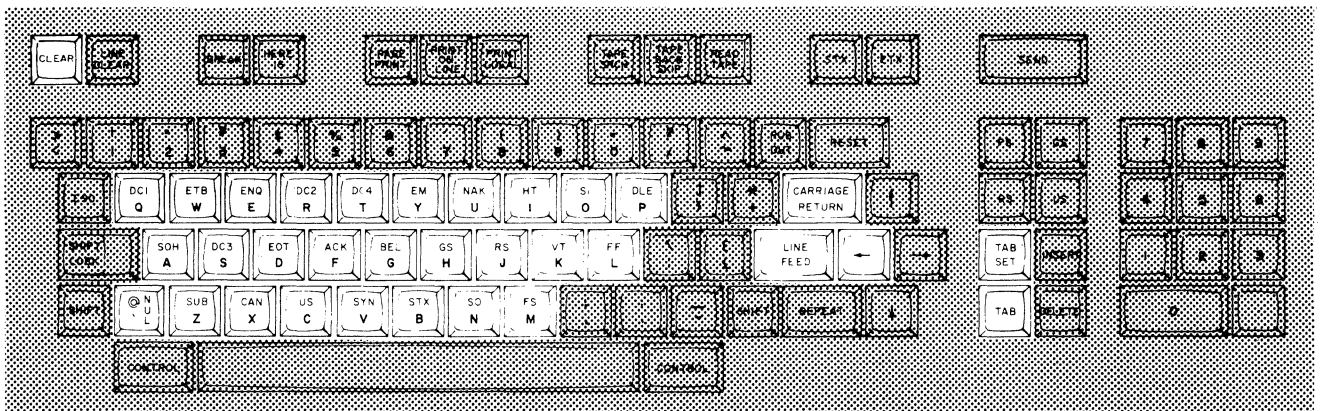

Figure CRT41. Special Control Code Keys

Procedure CRT26 — Adjusting Monitor

Two versions (CRT26A and CRT26B) of final monitor adjustments are covered in this procedure. Version A of CRT26 should be followed if adjusting monitors that have part numbers 61370900 or 61370902. Use the B version when performing adjustments on monitors with part number 61370905. The P/N 61370905 monitor (the new version) can be identified by the crt ground clip and ring magnet assembly on the crt neck.

Procedure CRT26A — Final adjustments on P/N 61370900 and P/N 6137902 monitors.

If raster is tilted, left or right side of screen is distorted, or raster is not centered on screen: perform horizontal and vertical alignment (procedure CRT14) before making further video adjustments.

WARNING

High voltage is present in the crt monitor when power is applied. Exercise caution when performing the following adjustments.

To make video (displayed characters) adjustments, perform the following:

- 1) Press POWER ON/OFF switch to OFF.
- 2) Remove cabinet hood (procedure CRT21).
- 3) Position TEST/NORMAL switch (rear panel) to TEST.
- 4) Press POWER ON/OFF switch to ON. Wait 30 seconds.
- 5) If checksum display appears on screen (figure CRT56), proceed with adjustments (step 6); otherwise perform the following:
 - a) Turn INTENSITY knob on front panel clockwise until raster appears.
 - b) If no raster, go to sheet 1, table CRT1, DDLT for Display Terminal.
 - c) Increase video gain by turning contrast control (figure CRT42) clockwise until checksum characters appear on display.
 - d) If no video appears, go to sheet 1 of table CRT1, DDLT for Display Terminal.
 - e) When checksum appears on display, proceed with adjustments (step 6).
- 6) ALERT light should be on. If not, replace ALERT indicator (procedure CRT10) after monitor adjustments are made.
- 7) Press space bar on keyboard three times.

Video Size Adjustments:

- 8) Adjust vertical height by turning adjustment screw (figure CRT42) until rectangle of display characters is 5.25 ± 0.1 inches (13.3 cm) in height.
- 9) Adjust horizontal width to 8.0 ± 0.1 inches (20.3 cm) by turning adjustment screw in coil (figure CRT42) using a $3/32$ -inch nonmetallic hex driver.
- 10) Reduce video gain to zero by turning contrast adjustment screw (figure CRT42) fully counterclockwise.
- 11) Turn INTENSITY control on front panel fully counterclockwise.
- 12) Adjust contrast control R2A fully clockwise.
- 13) Turn front panel INTENSITY control clockwise to the desired video viewing brightness. (Raster scan lines should not be visible.)

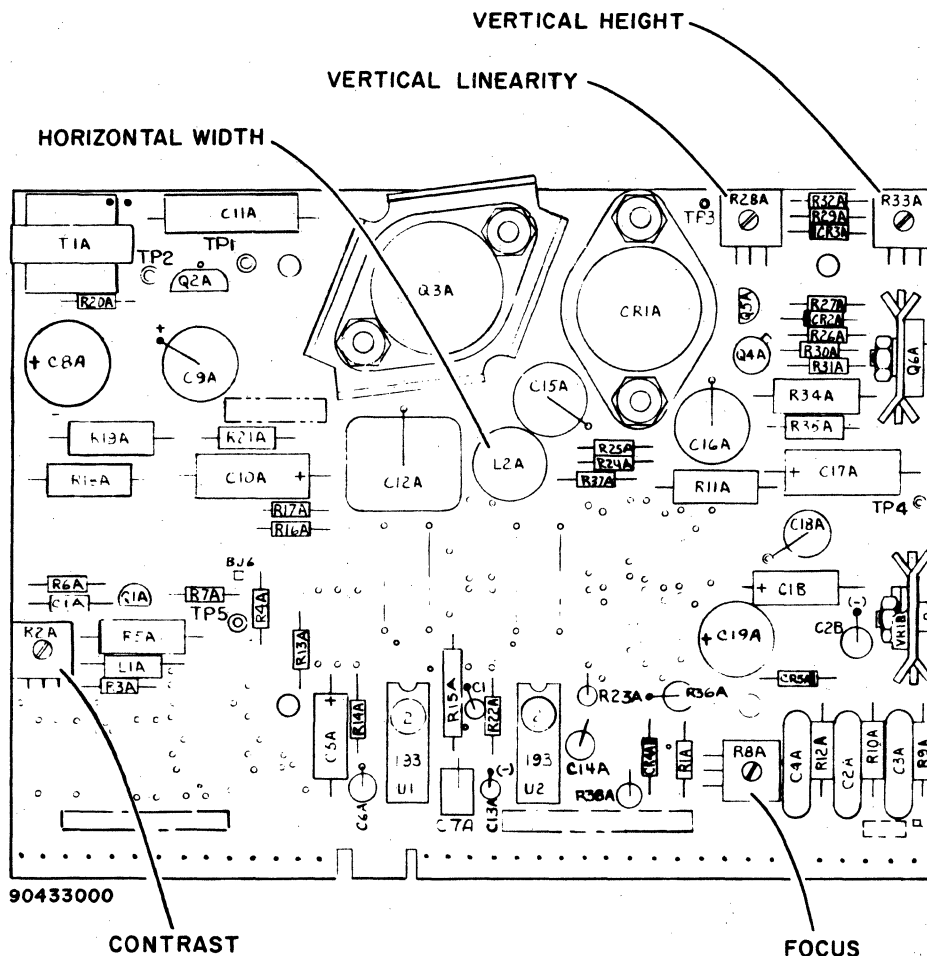

Figure CRT42. Monitor Printed-Circuit Board Adjustments (Video Size Adjustments)

- 14) Check top line, center line, and bottom line of displayed characters for uniformity. If characters are compressed anywhere on screen, turn vertical linearity adjustment screw (figure CRT42) clockwise or counterclockwise until character distortion disappears and all lines are equal in vertical size.
- 15) Adjust focus adjustment screw slot (figure CRT42) while observing characters on screen. Turn focus adjustment screw clockwise until dots (each character dot matrix) elongate toward upper-right corner of display screen. Then turn focus control slowly counterclockwise until elongated dots pull back to form round dots and entire screen is without fuzziness.

Procedure CRT26B — Final adjustments (video size, focus and geometric distortion adjustments) on P/N 61370905 monitors.

If character display is tilted, not centered, or linearity problems exist; perform the horizontal and vertical linearity adjustments (procedure CRT14) before doing this procedure.

WARNING

High voltage is present in the crt monitor when power is applied. Exercise caution when performing the following adjustments.

- 1) Press POWER ON/OFF switch to OFF.
- 2) Remove cabinet hood (procedure CRT21).
- 3) Position TEST/NORMAL switch (rear panel) to TEST.
- 4) Press POWER ON/OFF switch to ON. Wait 30 seconds.
- 5) If checksum display appears on screen (figure CRT56), proceed with adjustments (step 6); otherwise perform the following:
 - a) Turn INTENSITY knob on front panel clockwise until raster appears.
 - b) If no raster, go to sheet 1, table CRT1, DDLT for Display Terminal.

Video Size Adjustments:

- 6) Press space bar on keyboard three times.
- 7) Adjust vertical height by turning adjustment screw (figure CRT43) until rectangle of display characters is 5.25 ± 0.1 inches (13.3 cm) in height.
- 8) Adjust horizontal width to 8.0 ± 0.1 inches (20 cm) by turning adjustment screw in coil (figure CRT43) using a 3/32-inch nonmetallic hex driver.

Focus Adjustments:

- 9) Enter a full display of lower case m characters.
- 10) Turn front panel INTENSITY control maximum clockwise, then back it off approximately 1/4 of a turn.
- 11) Turn contrast control to its maximum clockwise position.
- 12) Adjust the INTENSITY RANGE control (figure CRT43) so that the raster (background scan lines) just disappear and a normal viewing intensity is obtained.

NOTE

Only the video (m characters) should be visible at this setting. The raster, however, should be present when the front panel INTENSITY control is turned to maximum.

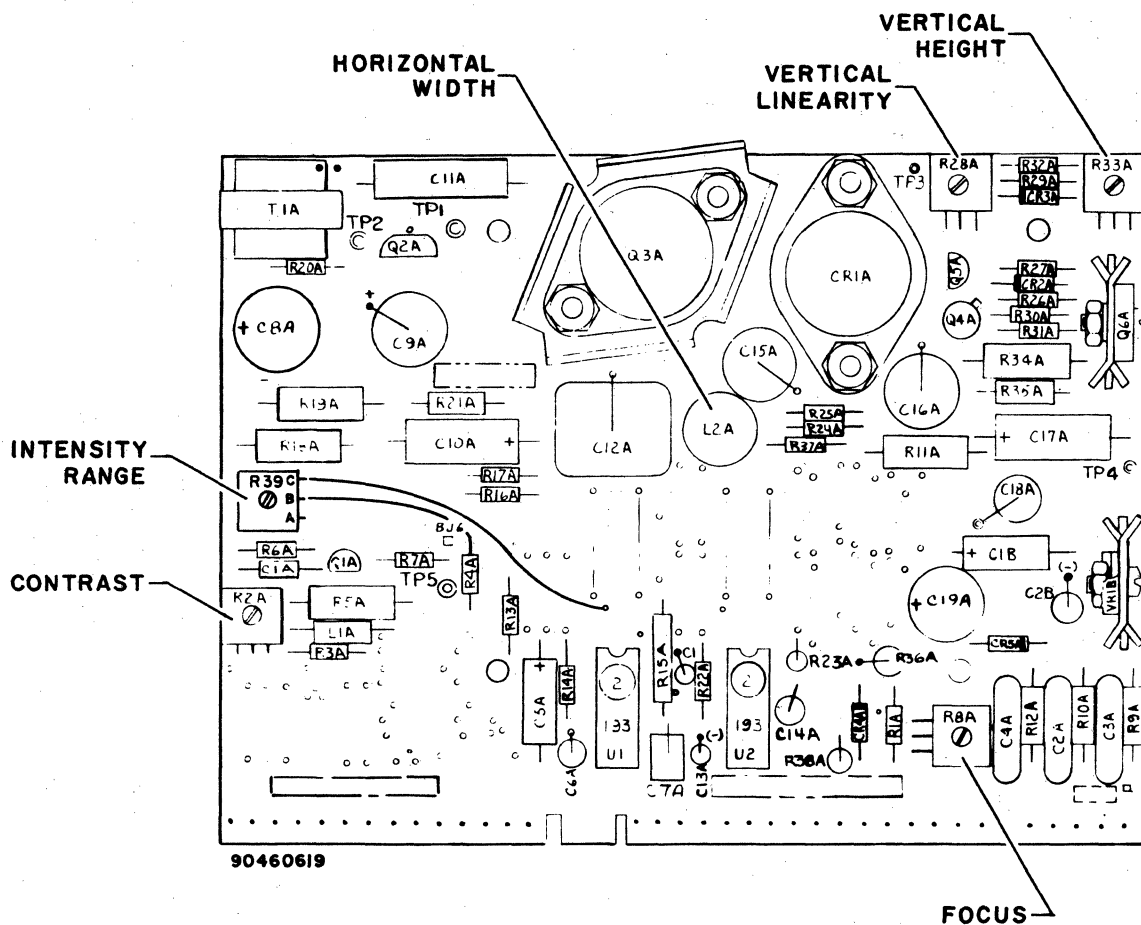

Figure CRT43. Monitor Printed-Circuit Board Adjustments (Focus Adjustments)

- 13) Adjust the FOCUS control (figure CRT43) to obtain the best resolution of the m characters throughout the entire display.
- 14) Adjust the focus magnet rings (figure CRT44) to reduce to a minimum any tails or halos visible on the characters. Especially those characters located in the corners of the display.
- 15) If necessary, repeat steps 12, 13, and 14 to obtain best possible character resolution over entire screen. Refer to figure CRT45 for particular characteristics of characters to be observed.
- 16) If tails are still present, try using an 18-gauss (part number 51917062) ring magnet assembly in place of original. If tails reverse direction 180° use a 14-gauss (part number 51917061) ring magnet instead of original assembly.

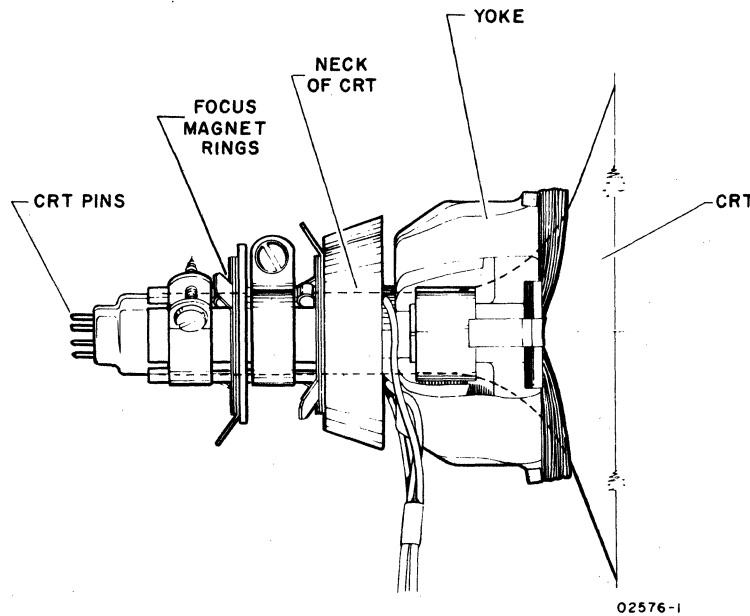

Figure CRT44. Adjusting Focus Ring Magnet Assembly

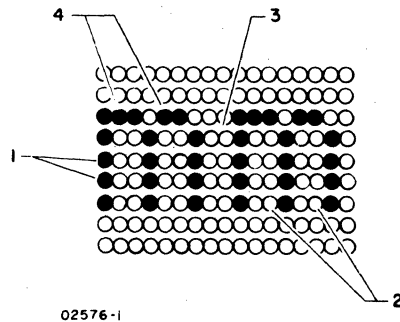

Figure CRT45. Display Character Resolution

Geometric Distortion Checks and Adjustments:

In the following steps, the rectangle of displayed characters is checked for barrel/pincushioning distortion. If the check indicates that correction is required, the following items will be needed:

- 1/4-inch diameter wooden dowel approximately 12 inches long
 - 1/4-inch masking tape
 - Cutting tool or scissors
 - Crt plastic overlay to fit a 12-inch crt (see figure CRT49 for ordering information).
 - Adhesive, part number 51004063
 - 1.5-gauss correction magnet (orange code) part number 51907050
 - 2.0-gauss correction magnet (yellow code) part number 51907051
 - 3.0-gauss correction magnet (silver code) part number 51907052
- 17) Plastic overlay has ideal rectangle marked on surface to help align raster. Cut where indicated to fit crt screen.
- 18) Using masking tape, fasten the overlay over the screen (figure CRT46).

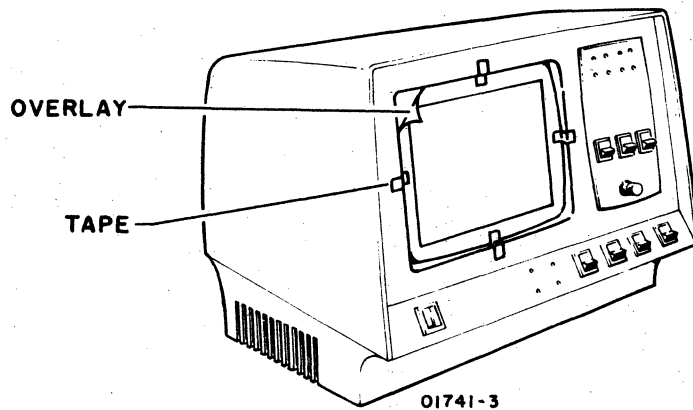

Figure CRT46. Applying Plastic Overlay to CRT Screen

- 19) Enter a display of H characters. Refer to steps 1 through 7 of Procedure CRT26A.
- 20) Observe the display to see if perimeter of displayed characters protrude either inside or outside the double line of the overlay. Ideally, the perimeter should align within the double lines of the overlay. If a horizontal or vertical edge deviates more than ± 0.05 inch from this ideal rectangle, the display is considered to be geometrically distorted and correction through performance of the following steps is required. Otherwise proceed to step 23.

- 21) By referring to figure CRT47 and the display, determine whether the perimeter edge requiring correction is caused by a barrel or a pincushion distortion.

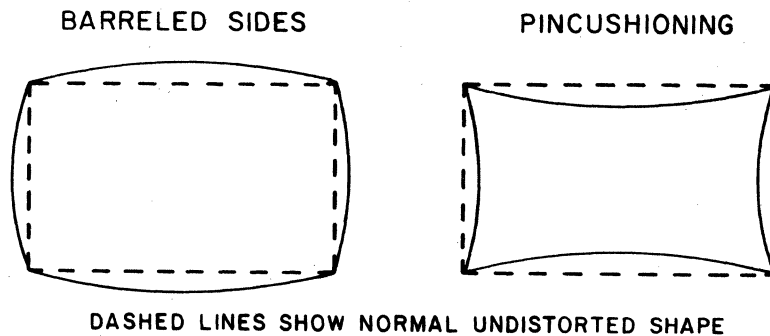

Figure CRT47. Identifying Raster Distortion

- 22) To correct pincushioning or barreling, first fasten a 1.5-gauss (orange coded) magnet to one end of wooden dowel. Use enough tape and wrap magnet to dowel securely enough so it cannot loosen and fall off (figure CRT48).

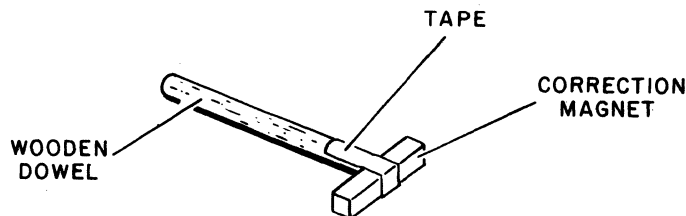
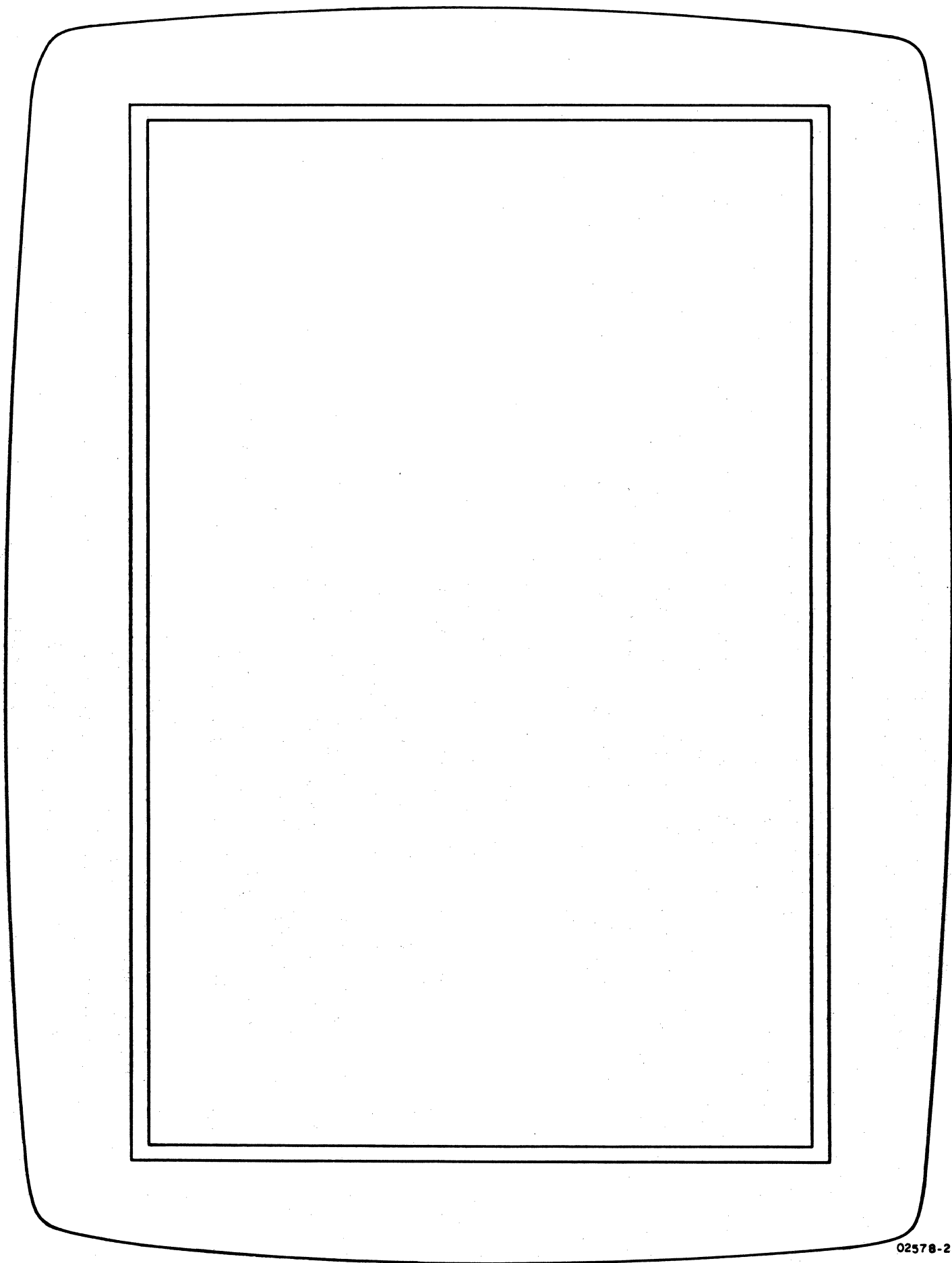

Figure CRT48. Installing Correction Magnet on Dowel

WARNING

Severe shock will be received if high-voltage transformer or lead to anode is touched.

- 23) From the rear of the display terminal maneuver the magnet on the rod along and up-down the side of the crt yoke which corresponds to the perimeter edge requiring correction, and monitor its reaction on the display. While doing this, attention must be given to the direction the colored end of the magnet is pointed. A magnet with its colored end pointed clockwise has the effect of pulling the edge out. A magnet with its colored end pointed counterclockwise has the effect of pushing the edge in. Be sure to keep the magnet away from the high-voltage transformer and crt anode lead. See figure CRT50,



02578-2

Figure CRT49. Example of Plastic CRT Raster Overlay

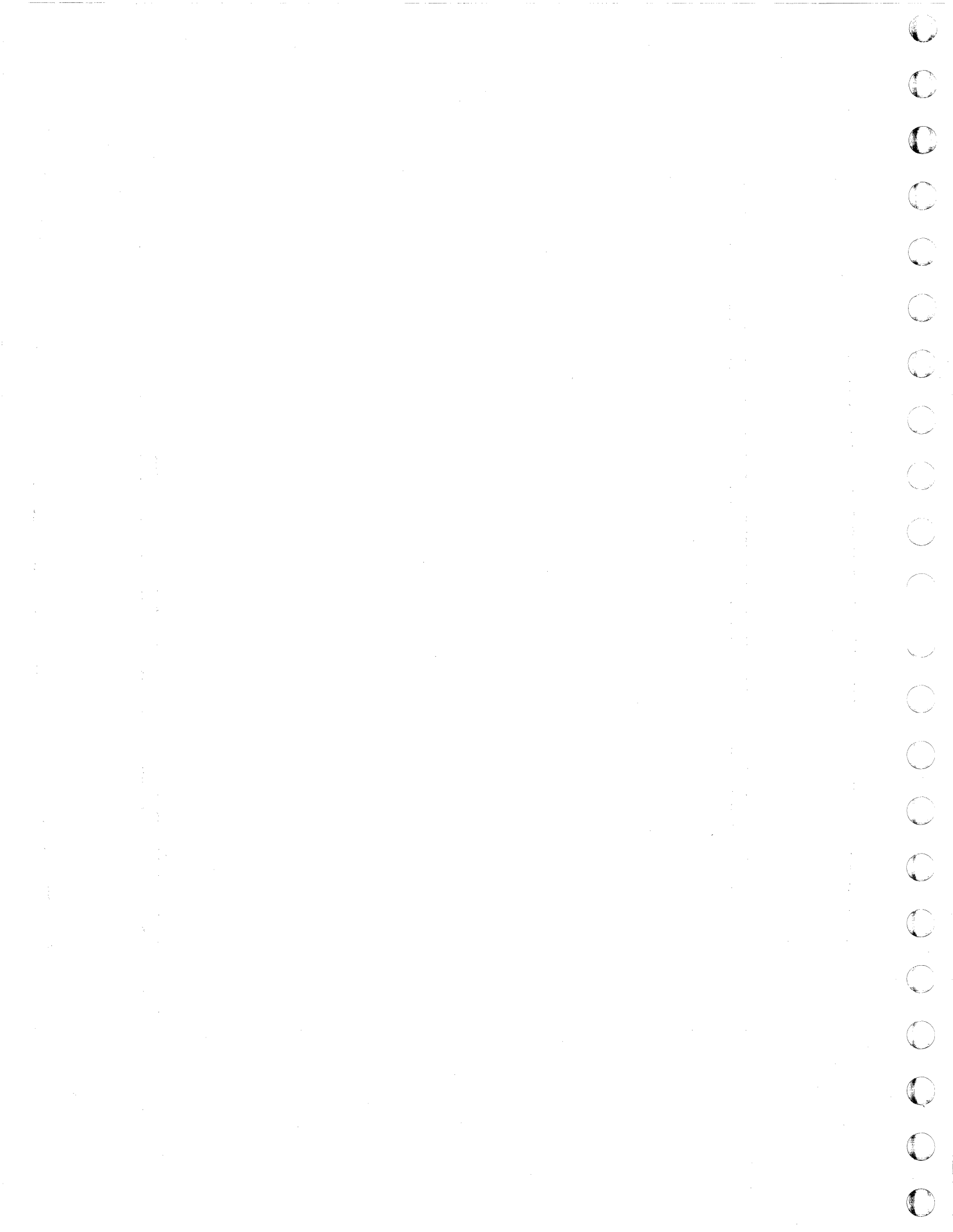

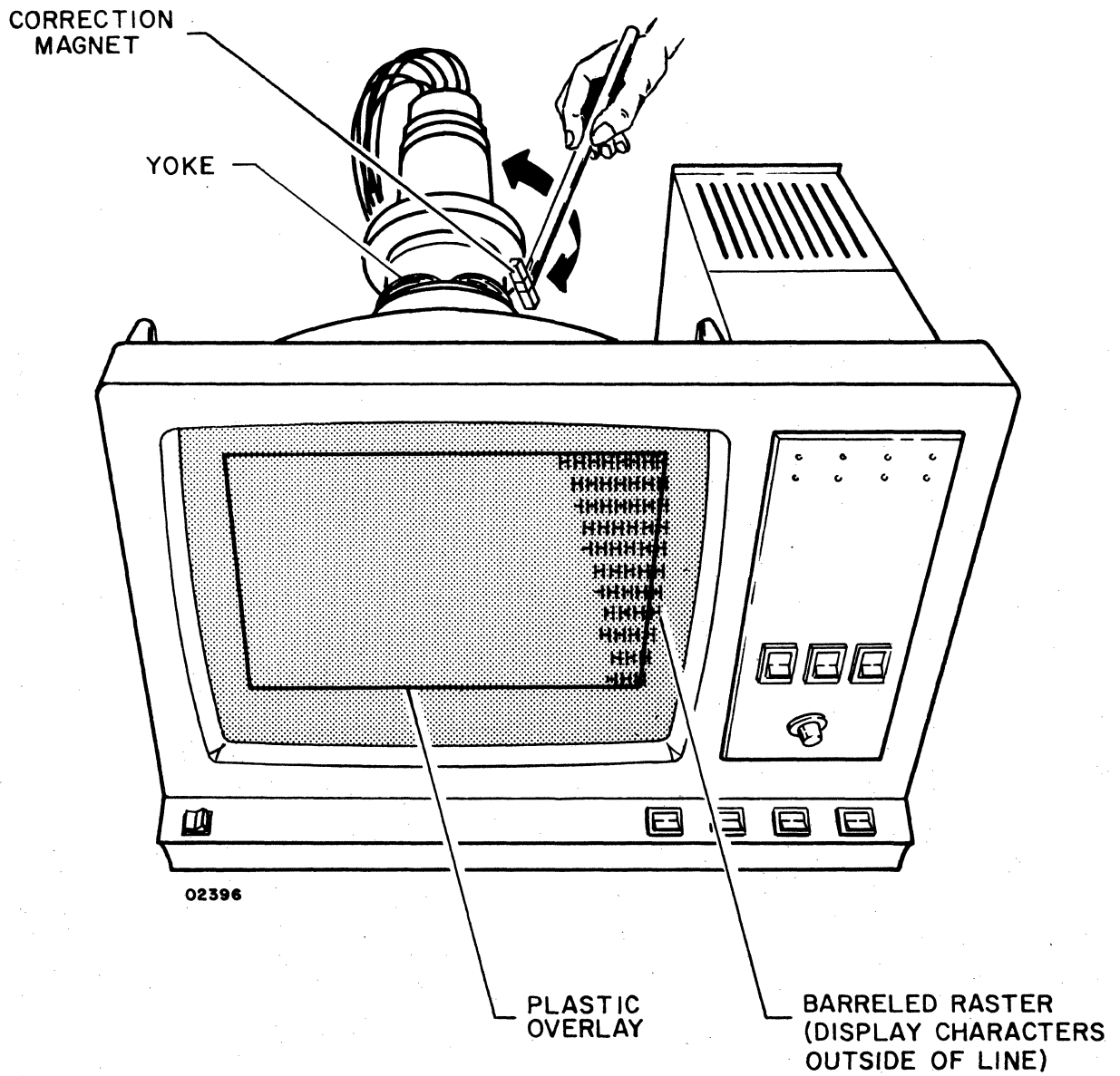

CAUTION

AVOID CONTACT WITH HIGH VOLTAGE
FLYBACK TRANSFORMER OR CRT ANODE LEAD

Figure CRT50. Positioning Correction Magnet to Yoke

- 24) When the desired correction is obtained, note the magnet position and turn crt power off.
- 25) Unfasten magnet from dowel and use adhesive to secure the magnet to the yoke coil. Verify that the colored end of magnet is pointed in the proper direction. It may be necessary to use masking tape to hold magnet in place during adhesive cure-time.
- 26) If required, correct the other perimeter edges in the same manner. Remove masking tape from magnets when adhesive has cured. Remove plastic overlay from crt screen and save it for possible future use.

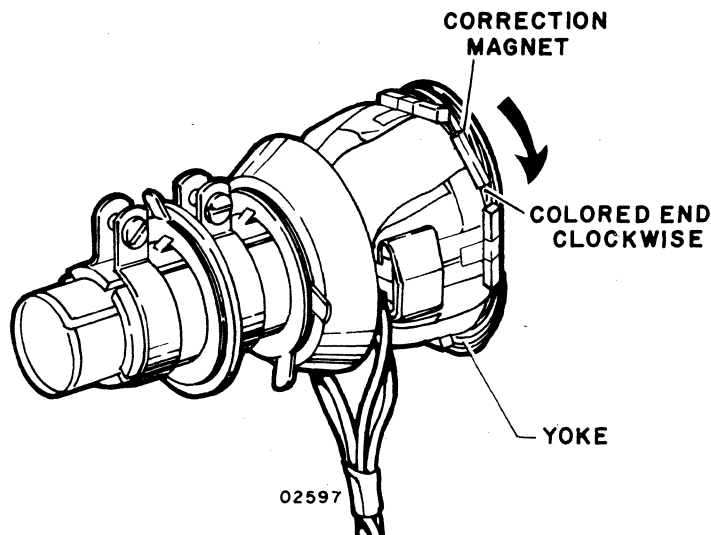

MAGNET ADDED TO YOKE TO CORRECT PINCUSHIONING (SEE NOTE)

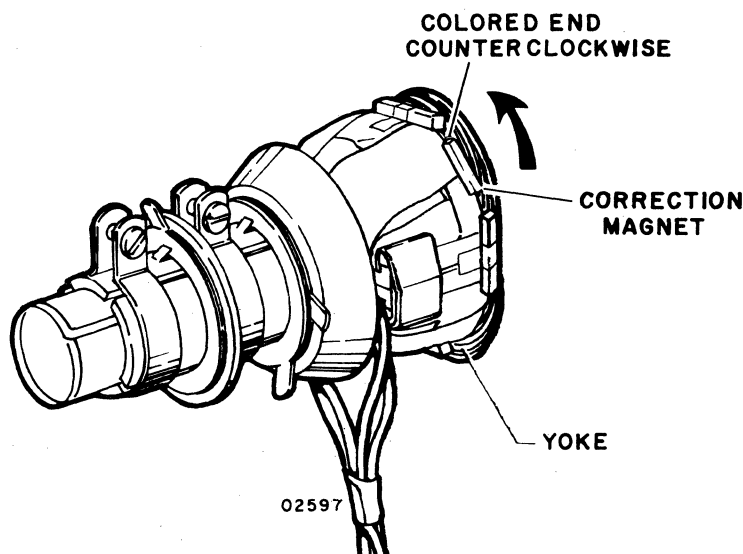

MAGNET ADDED TO YOKE TO CORRECT BARRELING (SEE NOTE)

NOTE: IF BOTH BARREL AND PINCUSHION DISTORTION WERE BEING CORRECTED, THE COLORED END OF THE CORRECTION MAGNETS WOULD BE PLACED ON THEIR RESPECTIVE SIDE OF THE YOKE AND THE RESULT WOULD BE A MIXTURE OF THE TWO EXAMPLES SHOWN.

Figure CRT51. Typical Positioning of Correction Magnets on Yoke

Procedure CRT27 — Checking and Replacing CHARACTER/LINE/BLOCK Switch

To check operation of switch, perform the following:

- 1) Press POWER ON/OFF switch to OFF.
- 2) Remove front switch-indicator panel by inserting fingers or knife between panel and bezel.
- 3) Check continuity between center black wire (pin S2-2) and top white wire (pin S2-1) with switch pressed to CHARACTER (up) position. Ohmmeter or continuity tester should indicate no resistance (closed circuit).
- 4) Keep meter test leads on top and center pins and move switch to center (LINE) and bottom (BLOCK) positions. Meter should indicate an open circuit in both positions.
- 5) Check continuity between black wire (center pin) and bottom white/brown wire (S2-3) with switch pressed to bottom (BLOCK mode) position. Meter should indicate a closed circuit (continuity). If circuit is open, replace switch (step 7, etc.).
- 6) With leads still attached to two bottom pins, press switch to center position and top position. Meter should show an open circuit in both switch positions. If a closed circuit is indicated, replace switch (step 7, etc.).

To remove switch, perform the following:

- 7) Press POWER ON/OFF switch to OFF.
- 8) If panel is not removed from bezel, insert fingers or knife between bezel and panel to remove.
- 9) Identify wires with masking tape: top white wire should be marked S2-1; center black wire should be marked S2-2; and bottom white/brown wire should be marked S2-3.
- 10) Slide wires from switch terminals.
- 11) Remove switch from panel by pushing it out from pin side of panel.

To install new switch, perform the following:

- 12) Insert switch into mounting hole in front of panel and press into place, making sure pins are oriented/offset same as other panel switches.
- 13) Slide wires on pins; S2-1 on top, S2-2 (black) in center, and S2-3 on bottom.
- 14) Position panel over mounting hole in chassis and press gently into bezel.

Procedure CRT28 — Checking and Replacing Two-Position Switches

To check out two-position switches on front panel, perform the following:

- 1) Press POWER ON/OFF switch to OFF.
- 2) Remove panel from chassis by inserting fingers or knife between panel and bezel.
- 3) Check continuity across two pins of switch as switch is moved to both positions. Meter should move in both directions, indicating open and closed circuits.

To remove two-position switches on front panel, perform the following:

- 4) With power off and panel separated from chassis, mark wires as necessary for proper reconnection, and slide wires from switch terminals.
- 5) Press switch out front of panel by pressing switch from inside of panel.

To install new switch, perform the following:

- 6) Press new switch into position through front of panel.
- 7) If switch is FULL DUPLEX/HALF DUPLEX, connect white wire to top pin (S4-1).
- 8) If switch is ON LINE/LOCAL, connect white wire to top pin (S5-1).
- 9) If switch is 64 CHAR/96 CHAR, connect brown/black/white wire to bottom pin (S1-3).
- 10) If switch is FORMAT, connect green/white wire to top pin (S2-1).
- 11) Black wire is always soldered to center pin.
- 12) If switch is POWER ON/OFF, solder all three yellow wires to appropriate pins as marked.
- 13) Press panel into hole in bezel carefully until it snaps into place.

Procedure CRT29 — Checking and Replacing Audible Alarm

This procedure is repeated in parts CRT29A and CRT29B to accommodate the two versions of audible alarms in the field. Procedure CRT29A describes how to service the alarm types that are mounted horizontally on the cabinet base of the monitor (in early version) figure CRT52. Procedure CRT29B covers the alarms that are mounted vertically on the side of the logic module card cage (in later version) figure CRT53.

Procedure CRT29A

To check alarm that is mounted horizontally along cabinet base perform the following:

- 1) Press POWER ON/OFF switch to OFF.
- 2) Press circuit breaker on rear panel down and unplug ac power cord.
- 3) Remove front panel strip containing POWER ON/OFF switch on the left side by inserting fingers or knife between panel and bezel near the DTR and REC indicators and then prying gently on panel near CHARACTER/LINE/BLOCK switch. Continue along edge of panel until entire panel is free from bezel.
- 4) Set ohmmeter to measure resistance at X 1 scale.
- 5) Insert red (+) probe through hole in bezel and touch Sonalert* alarm pin on right (marked "+"). It may be necessary to remove alarm from its mounting in order to check it (step 7, etc.).
- 6) While touching right pin with red lead, figure CRT52, insert black lead through hole in bezel and touch it to left lead. Thus touched, Sonalert must sound. If alarm does not sound, replace Sonalert.

To remove defective Sonalert, perform the following:

- 7) Remove defective Sonalert by prying it free from cabinet base and by gently feeding it out through the front panel strip slots. If hands are too big to remove Sonalert in this manner, first remove video module (procedure CRT12, steps 1 through 6) and then remove Sonalert by prying it away from floor of cabinet.
- 8) Pull terminals off Sonalert.

* Registered trademark of P.R. Mallory and Co. Inc.

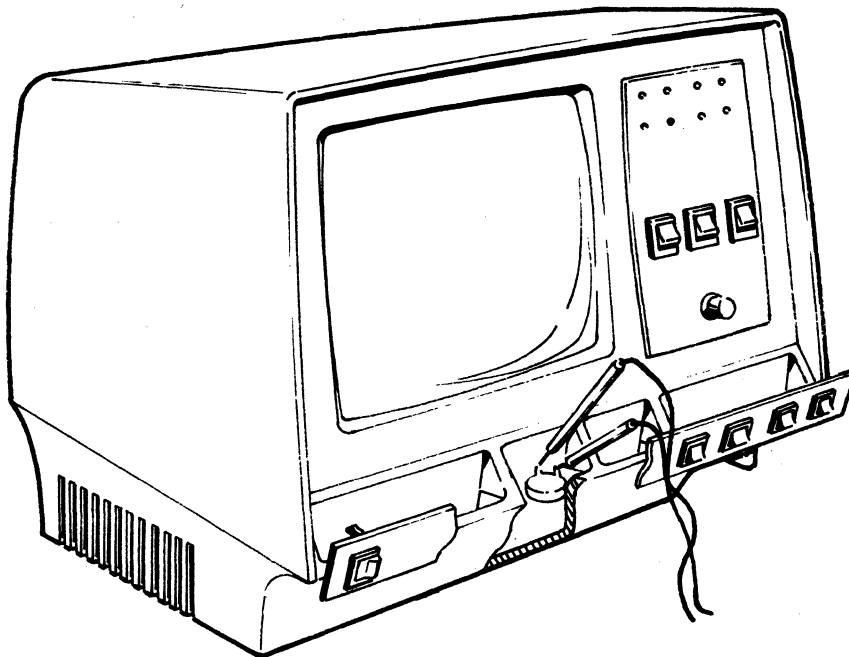

01967

Figure CRT52. Checking Horizontally Mounted Sonalet Alarm

To install new Sonalet, perform the following:

- 9) Press new Sonalet into mounting snap.
- 10) Slide red wire terminal on pin marked "+".
- 11) Slide black wire terminal on remaining pin.
- 12) If video module was removed in step 7, replace it (procedure CRT12, steps 7 through 15).

Procedure CRT29B

To check alarm, that is mounted vertically along logic chassis side frame, perform the following:

- 1) Press POWER ON/OFF switch to OFF.
- 2) Press circuit breaker on rear panel down and unplug ac power cord.

- 3) Remove video module by following steps 1 through 7 in procedure CRT12. After removal of video module, locate Sonalert alarm on logic chassis assembly. The Sonalert is mounted to the lower vertical portion of the logic chassis side frame. See figure CRT53.

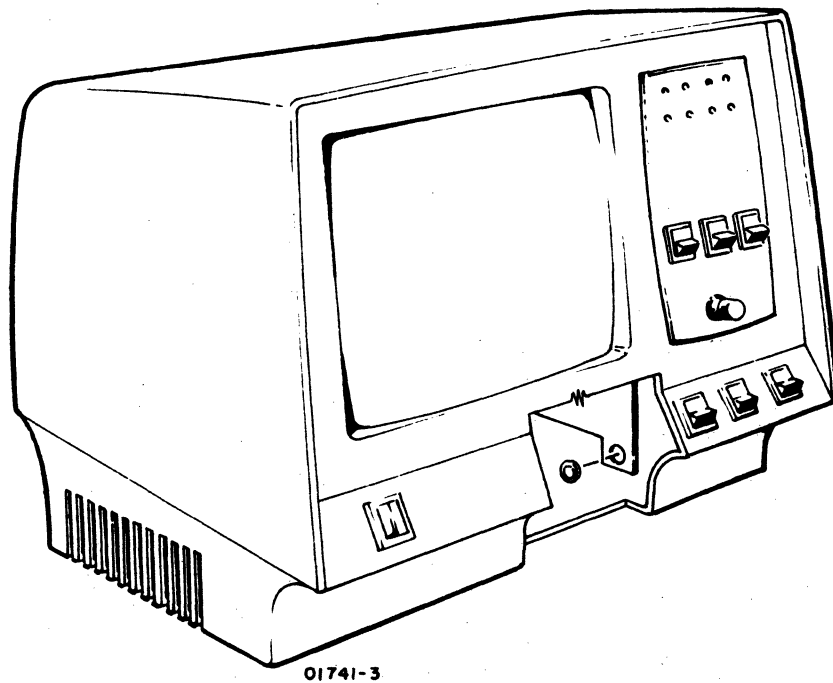

Figure CRT53. Location of Vertically Mounted Sonalert Alarm

- 4) Set Ohmmeter to measure resistance at X1 scale.
- 5) Attach red (+) probe to Sonalert alarm (pin marked "+"). See figure CRT54.
- 6) While touching Sonalert + pin with ohmmeter red lead (+) take ohmmeter black lead (-) and touch to - pin of Sonalert. Thus touched, Sonalert must sound. If alarm does not sound, replace Sonalert.

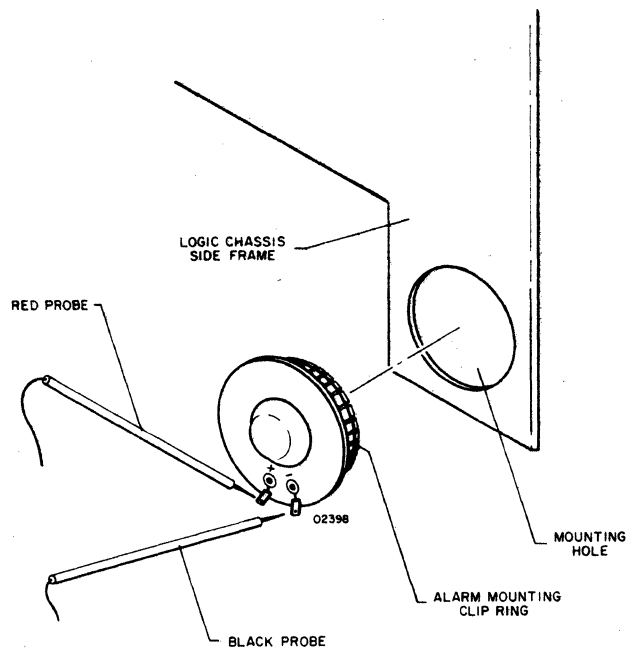

Figure CRT54. Checking Sonaalert Alarm

To remove defective Sonaalert, perform the following:

- 7) Label the wire going to Sonaalert + pin as the + wire and mark wire going to other pin as the - wire.
- 8) Disconnect terminals from the Sonaalert + and - pins.
- 9) Remove Sonaalert from side frame by prying around Sonaalert body until plastic snaps release the alarm from side frame hole.

To install new Sonaalert, perform the following:

- 10) Press Sonaalert into mounting hole located on lower portion of logic chassis assembly. With constant pressure, unit should snap into place.
- 11) Connect the previously marked + wire to the + pin of the Sonaalert.
- 12) Connect the previously marked - wire to the - pin of the Sonaalert.
- 13) Replace video module according to steps 8 through 16 in procedure CRT12.

Procedure CRT30 — Adjusting Refresh Stability

The following procedure is necessary only for those units that have refresh boards containing potentiometer R29 (needed to make refresh stability adjustment). Later refresh boards automatically correct for any unstable video. These refresh boards do not have a potentiometer to correct for unstable video.

If video display is unstable, that is, the entire character display appears to bloom in size in a pulsating fashion, perform the following:

- 1) Press POWER ON/OFF switch to OFF.
- 2) Remove cabinet hood (procedure CRT21).
- 3) Verify that 60-Hz refresh switch on memory card 08 (figure CRT55) is set to match cycles of input power.
- 4) Connect test point 23 on refresh board 06 to ground.
- 5) Press POWER ON/OFF to ON. Wait 30 seconds.
- 6) Turn up INTENSITY until raster scan lines are visible. Note a "swimming effect".
- 7) With small screwdriver, turn refresh stability adjustment (figure CRT55) counterclockwise/clockwise slowly until midpoint of nondistortion is reached. This indicates that video frequency is synchronized to display line frequency. If unable to stop instability, replace refresh board 06 (procedure CRT8).
- 8) Reduce intensity to normal, turn power off, and remove ground from test point. Also, replace cabinet hood if desired.

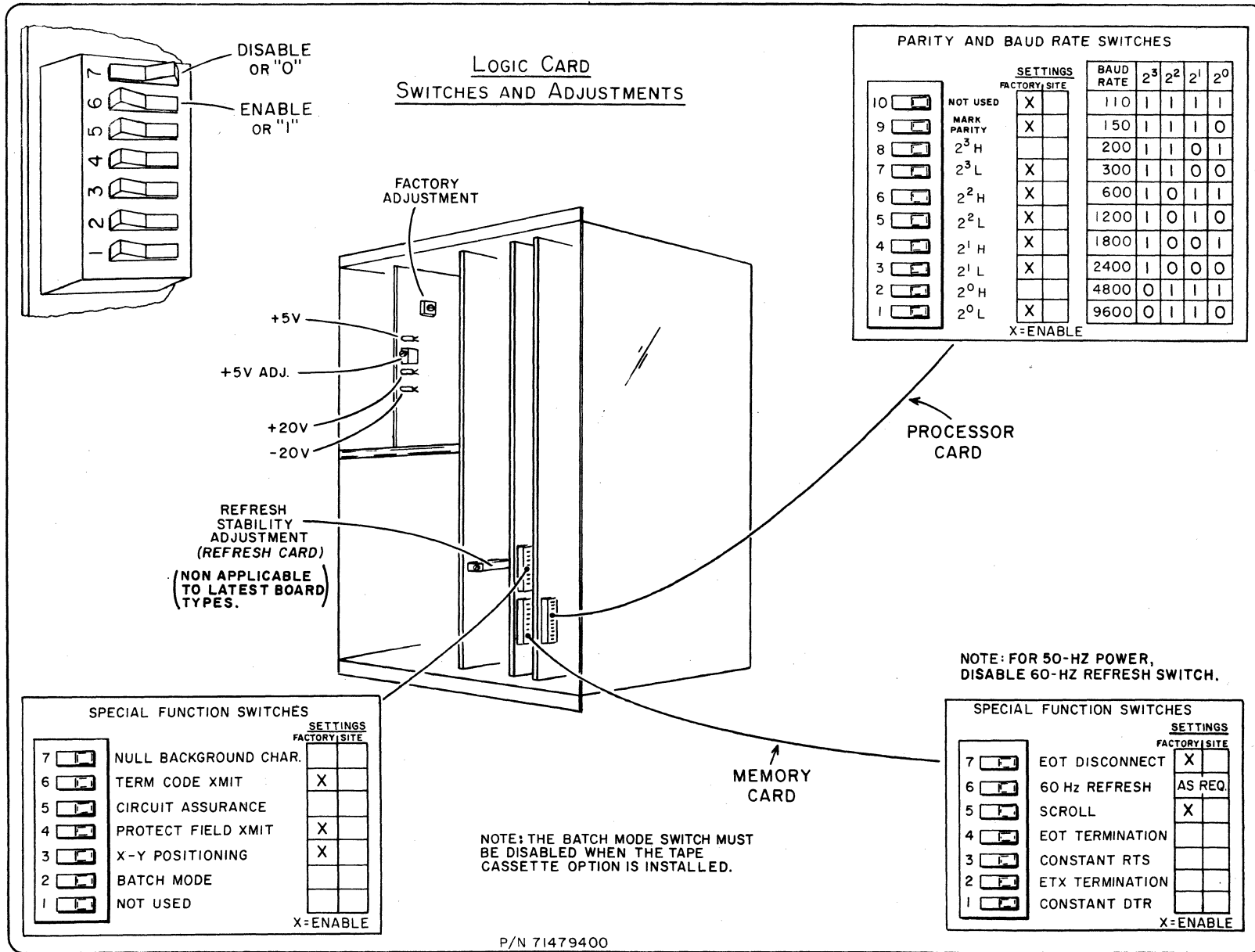

Figure CRT55, Sheet 1 of 2. Logic Module Decal (Switches and Adjustments)

MULTIDROP OPTION SPECIAL SWITCHES

S2

	SW.	SETTINGS	FACTORY	SITE
8	<input checked="" type="checkbox"/>	SW. CARRIER	X	
7	<input checked="" type="checkbox"/>	TEST POLL RPY TO SD	X	
6	<input checked="" type="checkbox"/>	SIC RESPONSE	X	
5	<input checked="" type="checkbox"/>	POLL ACK	X	
4	<input checked="" type="checkbox"/>	STOP ON ETX	X	
3	<input checked="" type="checkbox"/>	STOP ON STX	X	
2	<input checked="" type="checkbox"/>	STOP ON SOH	X	
1	<input checked="" type="checkbox"/>	UNBLIND ON SOH	X	

X=ENABLE

S1

		SETTINGS	FACTORY	SITE
8	<input type="checkbox"/>	NOT USED		
7	<input type="checkbox"/>	SEL SCC/SIC 2 ⁸		
6	<input type="checkbox"/>	SEL SCC/SIC 2 ⁹		
5	<input type="checkbox"/>	SEL SCC/SIC 2 ⁴		
4	<input type="checkbox"/>	SEL SCC/SIC 2 ³		
3	<input type="checkbox"/>	SEL SCC/SIC 2 ²		
2	<input type="checkbox"/>	SEL SCC/SIC 2 ¹		
1	<input type="checkbox"/>	SEL SCC/SIC 2 ⁰		

X=ENABLE

ENABLE OR "1" **DISABLE OR "0"**

P/N 71491943

EDIT ROM SPECIAL SWITCHES

S1

		SETTINGS	FACTORY	SITE
8	<input type="checkbox"/>			
7	<input type="checkbox"/>			
6	<input type="checkbox"/>			
5	<input type="checkbox"/>			
4	<input type="checkbox"/>			
3	<input type="checkbox"/>			
2	<input type="checkbox"/>			
1	<input type="checkbox"/>	WRAPAROUND		

P/N 71488900 REV

X=ENABLE

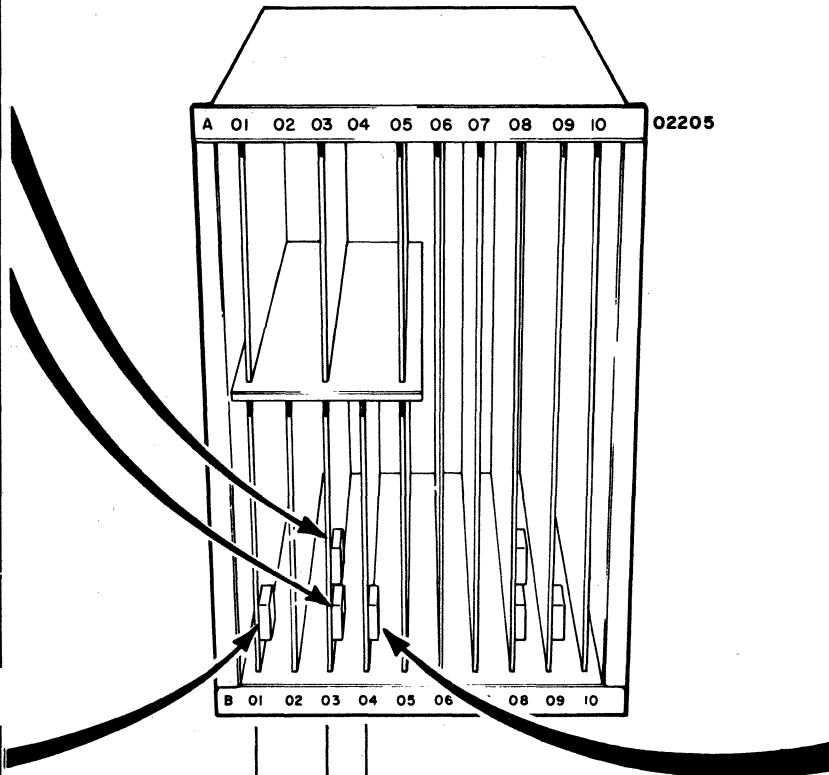

PRINTER CARD
MULTIDROP CARD
EDIT ROM CARD

PRINTER CONTROL SWITCHES

S1

		SETTINGS	FACTORY	SITE
7	<input type="checkbox"/>	AUTO PRINT	X	
6	<input type="checkbox"/>	2 ³ 2 ² 2 ¹ 2 ⁰	X	
5	<input type="checkbox"/>	2 ³ 2 ² 2 ¹ 2 ⁰	X	
4	<input type="checkbox"/>	2 ³ 2 ² 2 ¹ 2 ⁰		
3	<input type="checkbox"/>	2 ³ 2 ² 2 ¹ 2 ⁰		
2	<input type="checkbox"/>	EVEN PARITY	X	
1	<input type="checkbox"/>	INHIBIT PARITY		

X=ENABLE

ENABLE OR "1" **DISABLE OR "0"**

P/N 71486500 REV A

Figure CRT55, Sheet 2 of 2. Supplemental Function Switch Decals

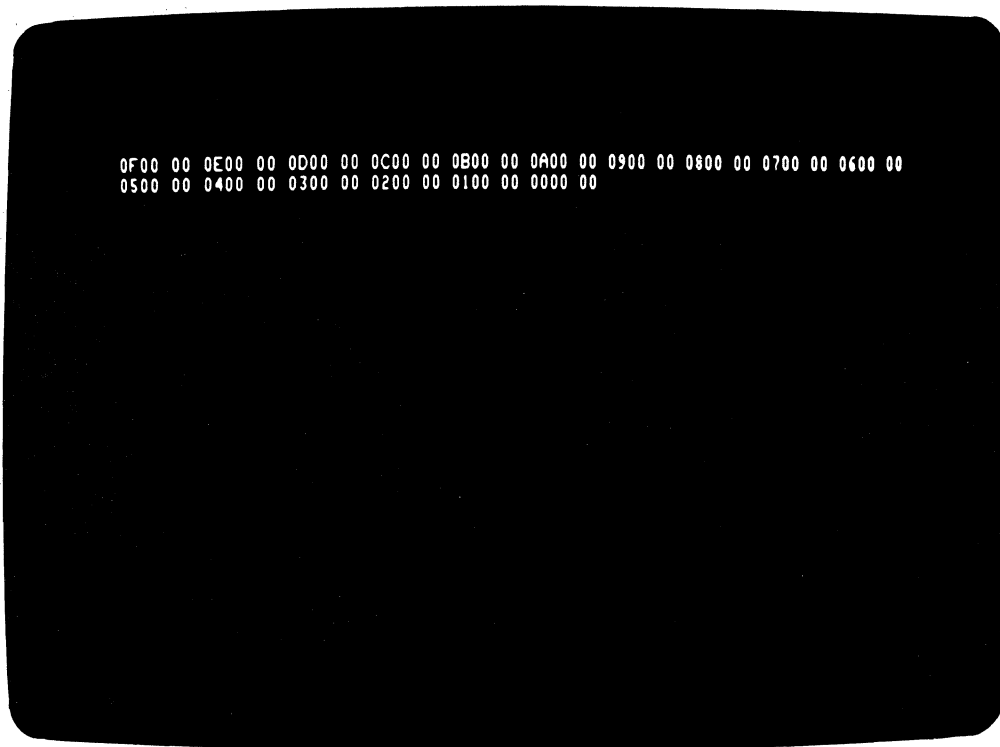

Figure CRT56. Checksum Display

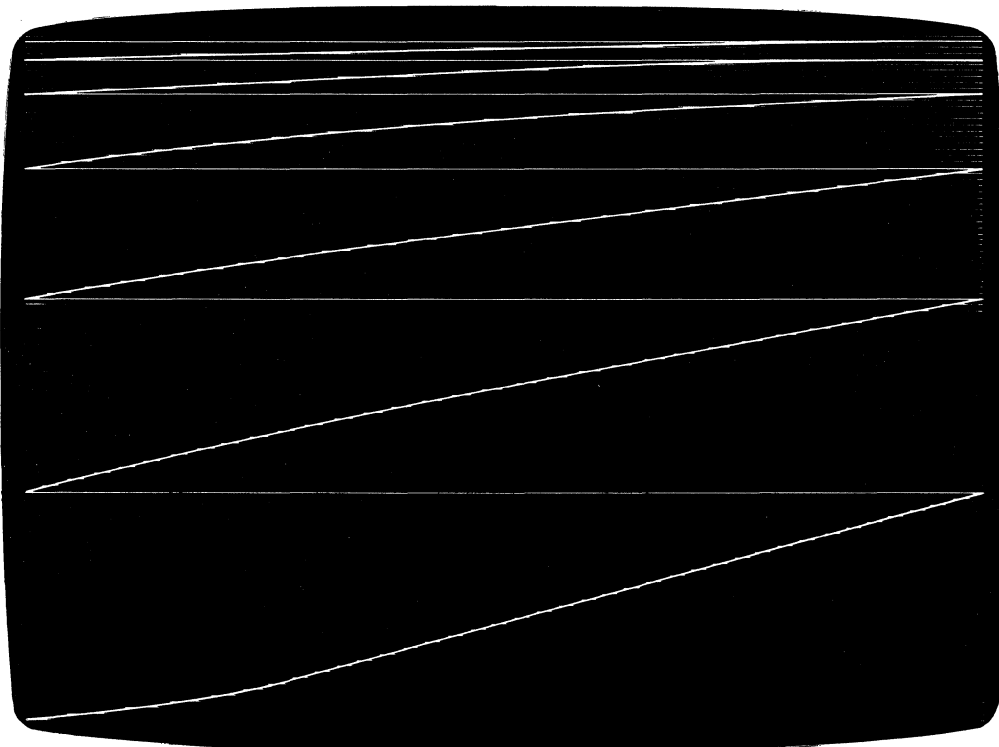
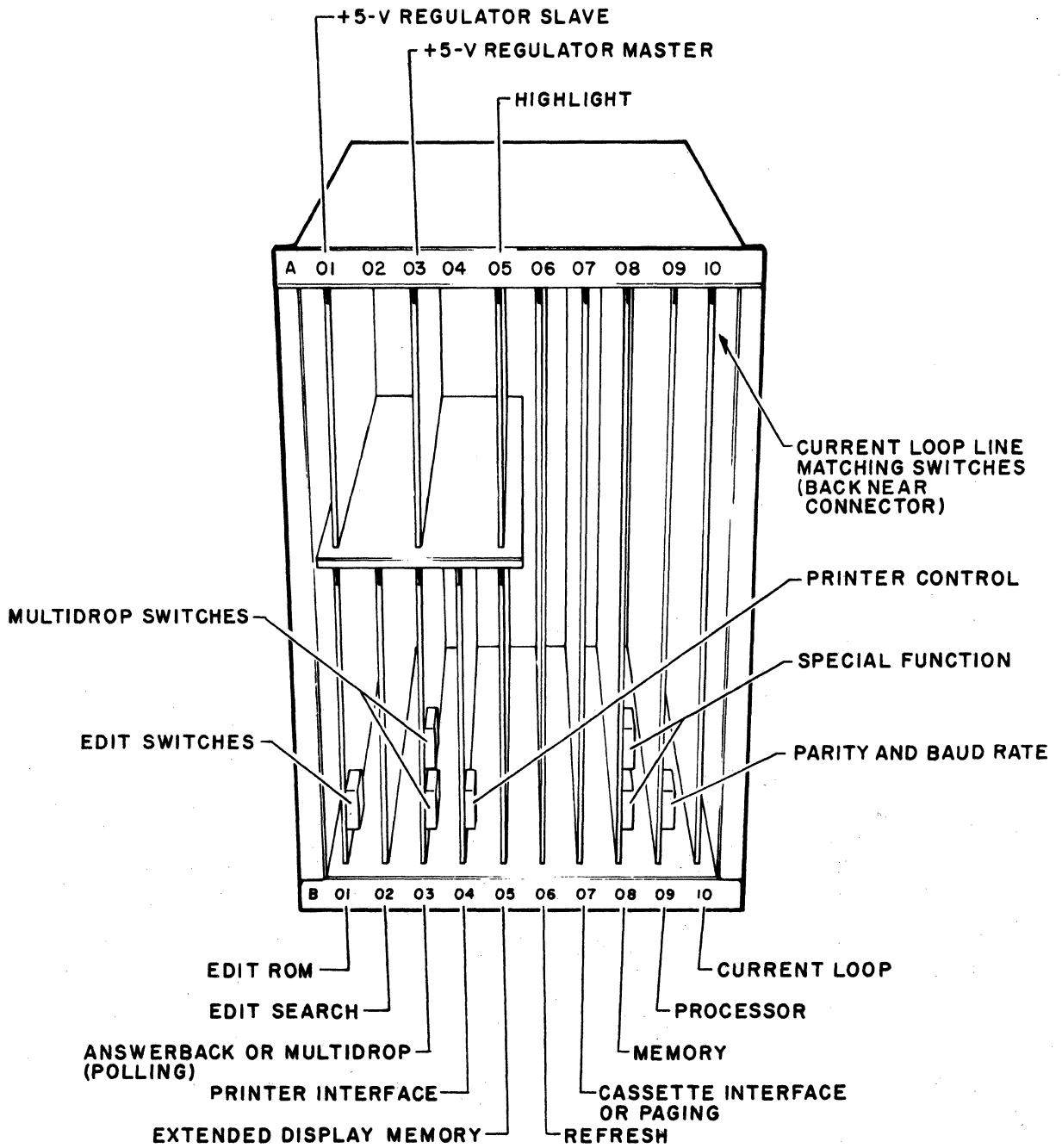

Figure CRT57. Raster Display



02205-1

Figure CRT60. Logic Module Board Locations

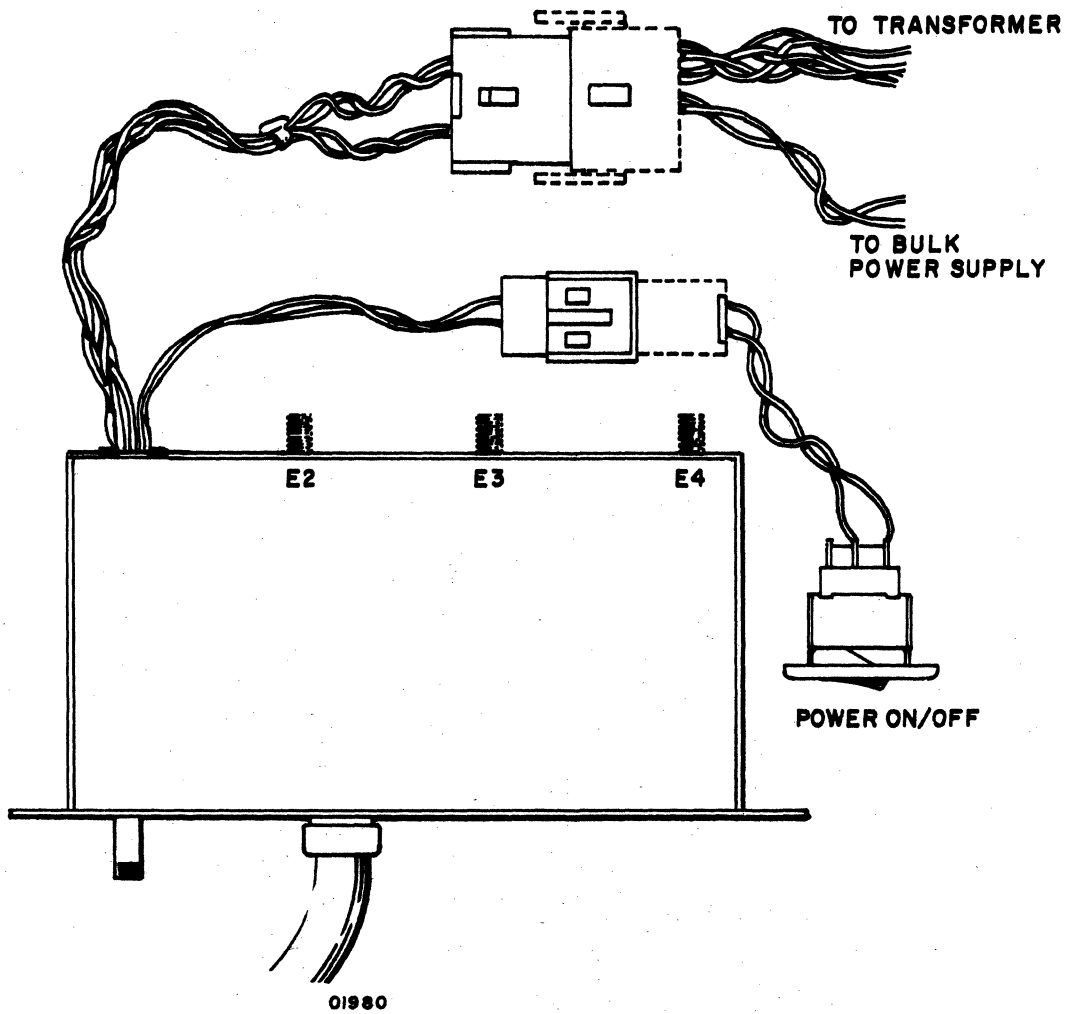
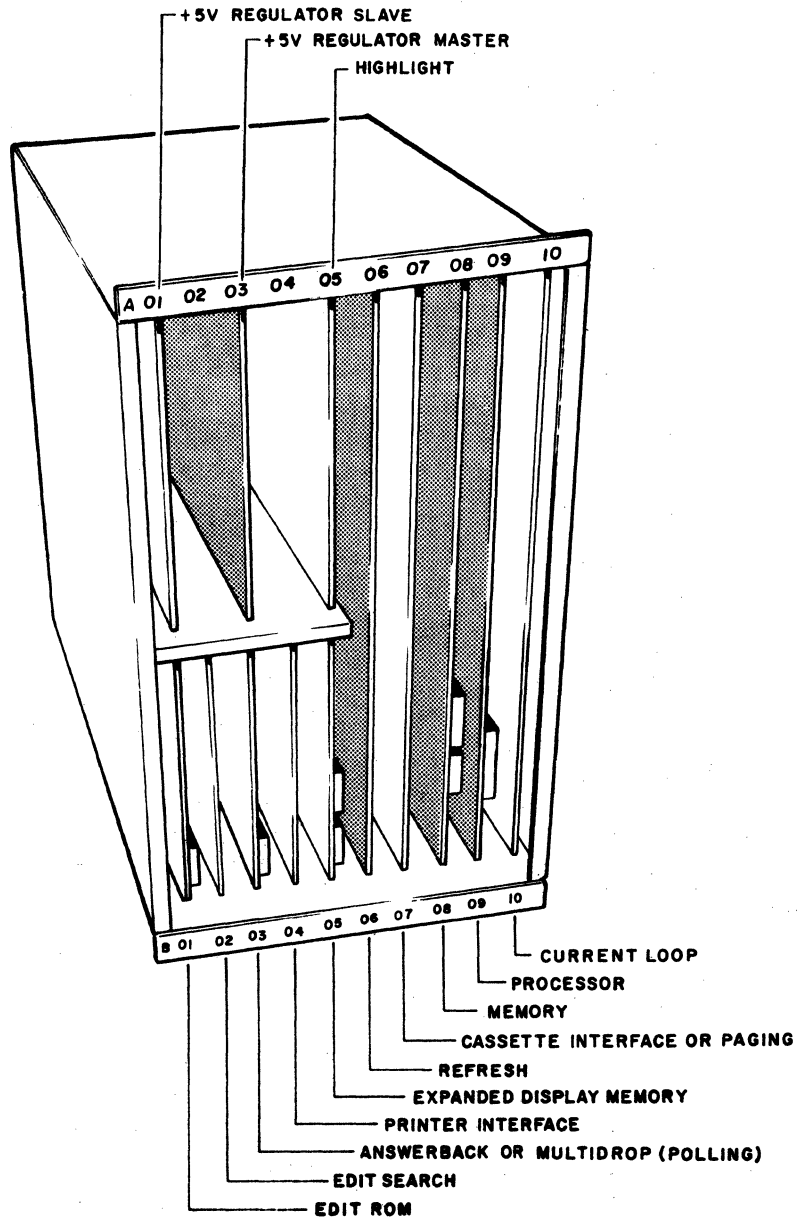

Figure CRT61. AC Power Cabling



01824-3

- = MINIMUM BASIC MODULE
- = SUPPLEMENTAL FUNCTION CARDS (OPTIONS)

Figure CRT62. Installed Options

Procedure CRT31 — Checking/Setting Auto Answerback ID Code

To check/set the auto answerback ID code, perform the following:

- 1) Remove answerback function card from display logic module (procedure CRT8).
- 2) Hold card carefully in position shown in figure CRT63 and read the binary value of each of the 21 possible characters. A diode plugged in across a bit position in a character row = binary 1 and no diode present = binary 0; thus figure CRT63 shows diode placement for the standard code sequence provided in an answerback card from the factory. This sequence is:

1. carriage return (015 _g)	8. E (105 _g)	15. T (124 _g)
2. line feed (012 _g)	9. R (122 _g)	16. E (105 _g)
3. delete (177 _g)	10. B (102 _g)	17. S (123 _g)
4. A (101 _g)	11. A (101 _g)	18. T (124 _g)
5. N (116 _g)	12. C (103 _g)	19. carriage return (015 _g)
6. S (123 _g)	13. K (113 _g)	20. line feed (012 _g)
7. W (127 _g)	14. space (040 _g)	21. delete (177 _g)

- 3) Set particular system-required series of ID characters (up to 21) by carefully pulling out and pressing in pluggable diodes to form proper series of binary character codes. Note that each of the 21 possible characters is a 7-bit ASCII character and the eighth (most significant) bit position is where a diode must be plugged to specify the last character desired in the series of up to 21. Any characters remaining after that which has the eighth bit plugged (set = 1) are not used as part of the ID code sequence and are ignored.
- 4) Replace answerback card in display logic rack (procedure CRT8).

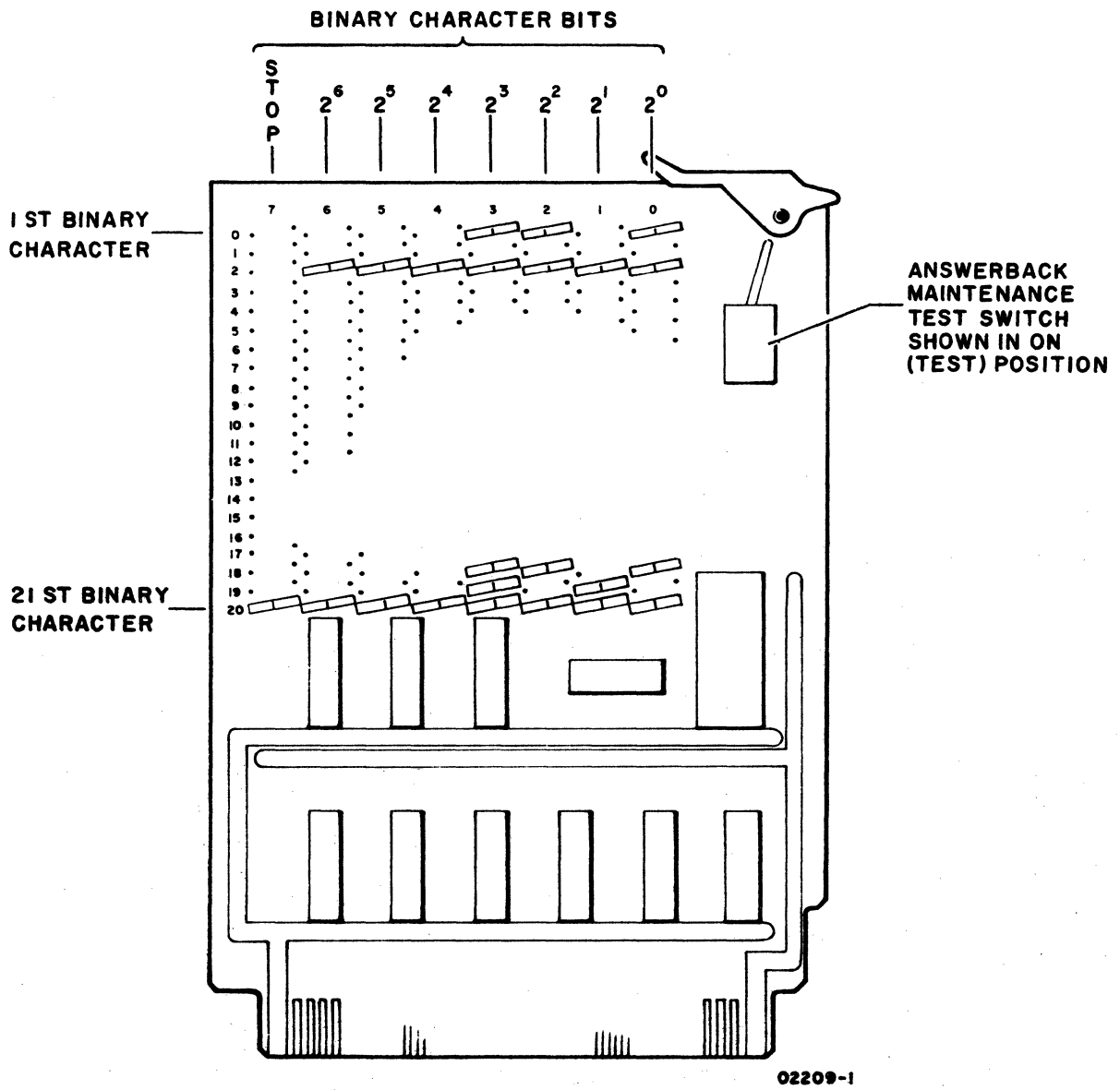

Figure CRT63. Answerback Pluggable-Diode Matrix Coding

Procedure CRT32 — Checking/Setting Current Loop Line-Adapter Switches

To check/set the current loop line-adapter switches, perform the following:

- 1) Remove current loop function card from display logic module (procedure CRT8).

CAUTION

To guard against burning out card rack circuits with current loop system high voltages, any/all switch setting changes must be done only with the current loop card removed. As described following close examination of completed switch settings for exact conformance with those allowed is required to guard against such damage when replacing card.

- 2) With card in position shown in figure CRT64, set each rocker so all eight rocker switches conform with one of the several acceptable current loop systems which these circuits may be adapted to via these switches. Figure CRT65 shows those systems and switch settings which are safe to use without causing damage to the card rack circuits in the display. Any other setting configuration must not be used unless thorough analysis of the current loop line-adapter card circuits proves it safe (see Preface of this manual for manual which contains detailed current loop card circuit information/diagrams). Use table CRT12 for identifying which current loop line is being opened/closed (open = logical 0 and closed = logical 1) by each switch.
- 3) Place current loop card in display logic rack (procedure CRT8).

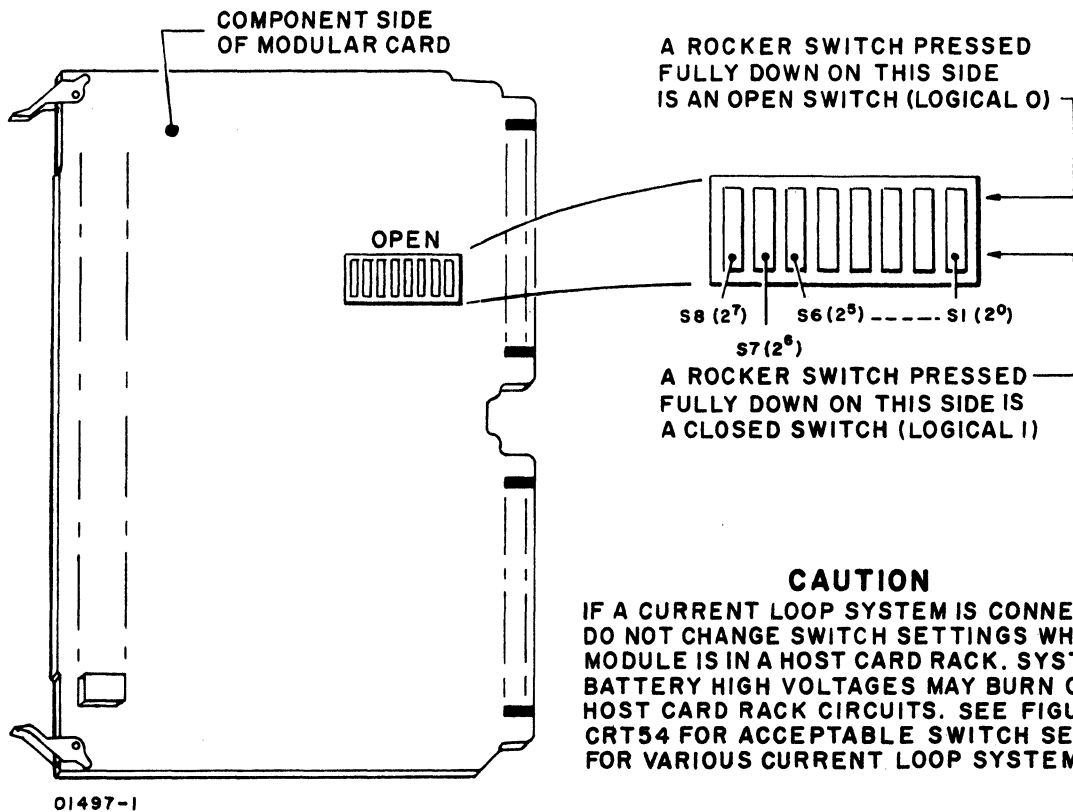
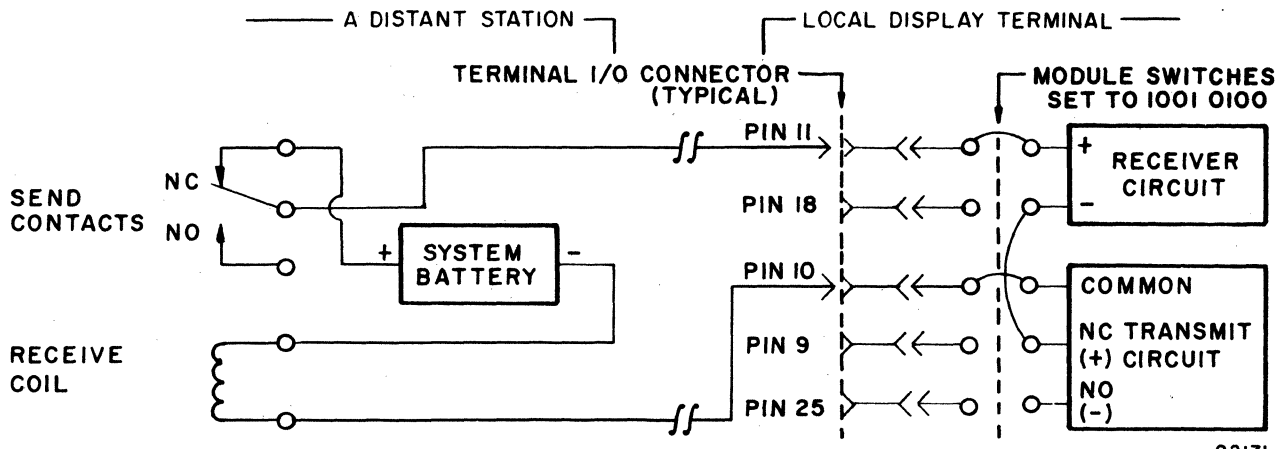

Figure CRT64. Current Loop Line-Adapter Switches

TABLE CRT12. CURRENT LOOP LINE-ADAPTER SWITCH DEFINITIONS

SWITCH	FUNCTION
S1 (2 ⁰)	Open/close the transmit (-) output line which is normally open.
S2 (2 ¹)	Open/close the transmit (+) output line which is normally closed.
S3 (2 ²)	Open/close the transmitter common output line.
S4 (2 ³)	Open/close the transmitter common output to the receiver (-) input.
S5 (2 ⁴)	Open/close the transmit (+) output to the receiver (-) input.
S6 (2 ⁵)	Open/close the receiver (-) input line.
S7 (2 ⁶)	Open/close the transmitter common output to the receiver (+) input.
S8 (2 ⁷)	Open/close the receiver (+) input line.



a. Unipolar Half Duplex Current Loop System with Switches set to 1001 0100

02171

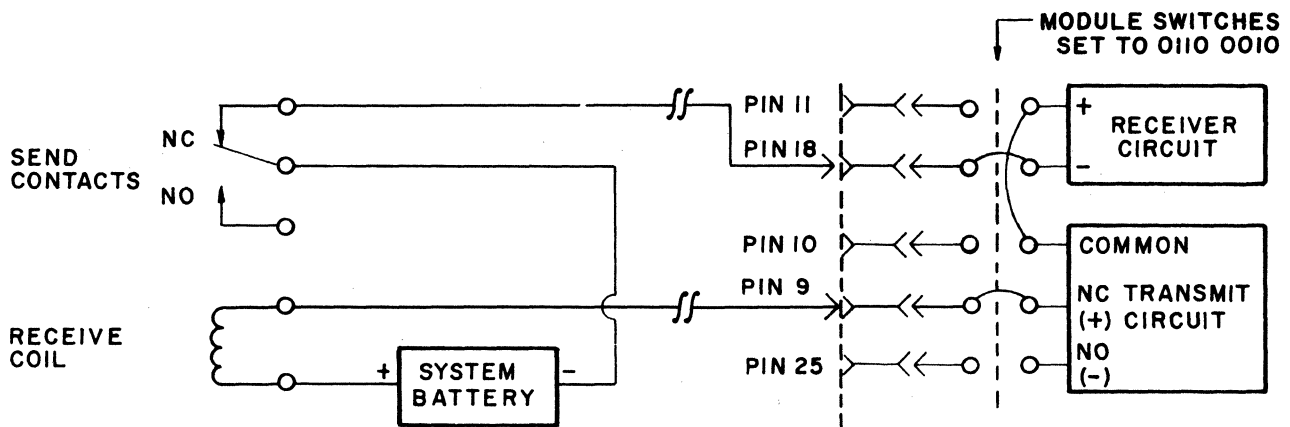

b. Unipolar Half Duplex Current Loop System with Switches set to 0110 0010

02171

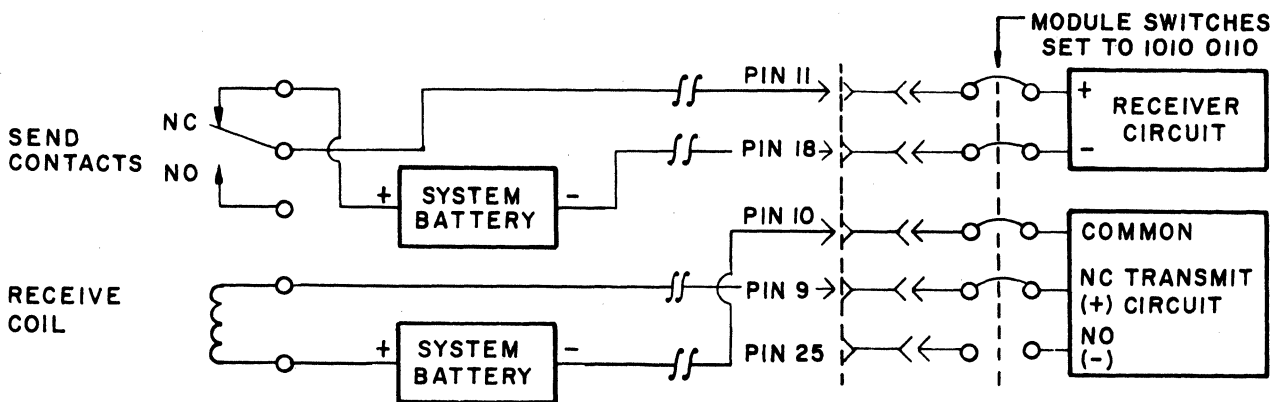

c. Unipolar Full Duplex Current Loop System with Switches set to 1010 0110

02171

Figure CRT65, Sheet 1 of 2. Current Loop Line-Adapter Switch Settings

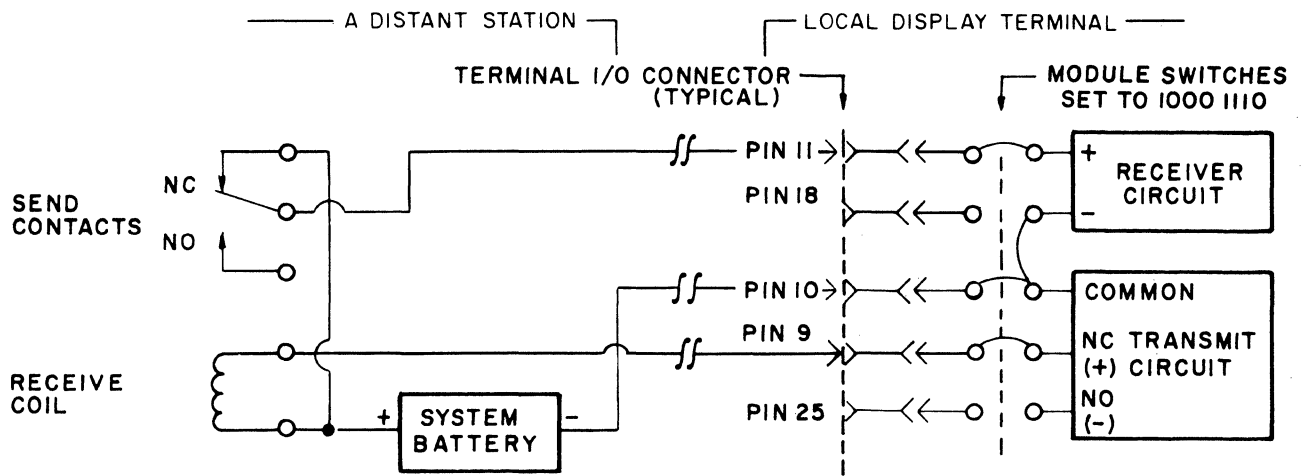

02171

d. Unipolar Full Duplex Current Loop System with Switches set to 1000 1110

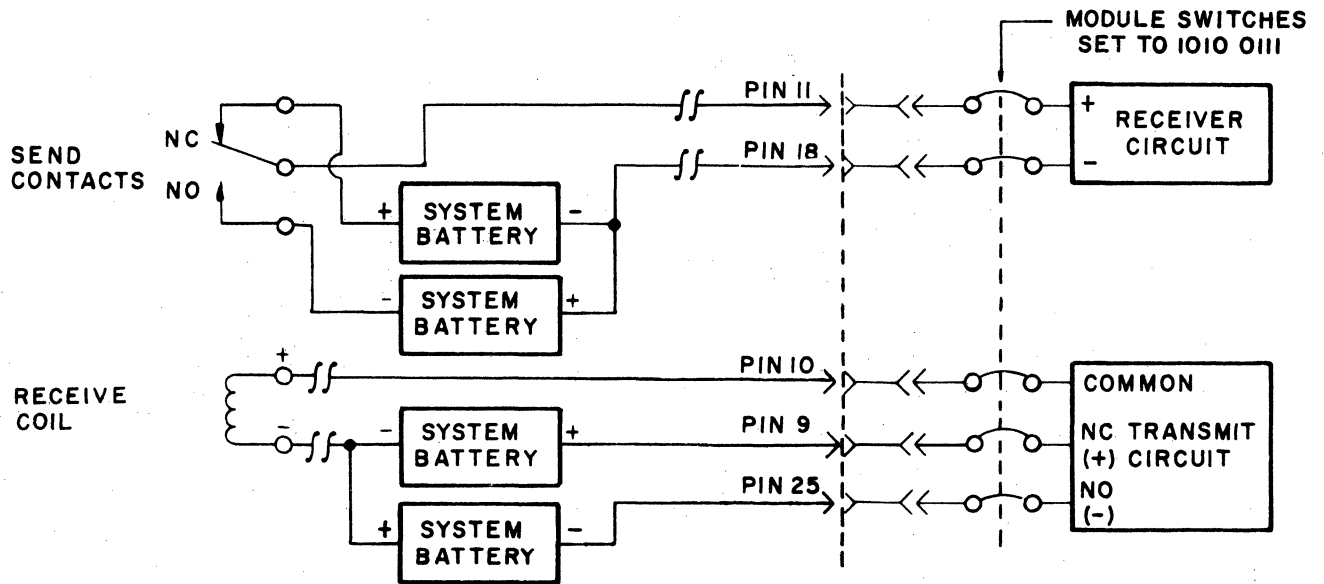

02171

e. Bipolar Full Duplex Current Loop System with Switches set to 1010 0111

Figure CRT65, Sheet 2 of 2. Current Loop Line-Adapter Switch Settings

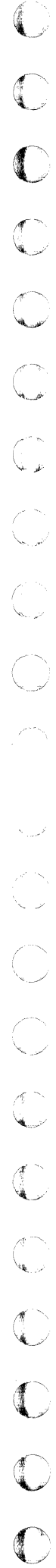

TABLE NIP1. DDLT FOR NONIMPACT PRINTER (SHEET 1 OF 2)

POWER ON, SWITCHES, AND SUBSYSTEM TEST SECTION 6 CHECKS								
ASSUME								
Printer I/O cable connected either to keyboard display PERIPHERAL CONNECTOR or PRINTER I/O connector on tape unit, if present (procedure TS1). Paper loaded in printer per procedure NIP1. Test section 3 of table CRT1 (sheet 4) ran OK and Test Mode in display is waiting to be advanced.								
CONDITIONS	SITUATIONS							
	1	2	3	4	5	6	7	8
Is power on at printer?	Y	Y	Y	Y	Y	Y	N	O T H E R
Does line feed (LF switch) operate correctly?	Y	Y	Y	Y	Y	N	-	
Does carriage return (CR switch) operate correctly?	Y	Y	Y	Y	N	-	-	
Activate PRINT ON LINE key on keyboard of keyboard display. Press spacebar twice. Does printer begin by printing a space character, continue by printing a 79-character line, and continue printing successive 79-character lines in a one-character-left shifting pattern? See Printer Diagnostic Test Pattern in appendix C.	Y	Y	Y	N	-	-	-	
Is printhead movement correct?	Y	Y	N	-	-	-	-	
Do all characters print?	Y	N	-	-	-	-	-	
ACTIONS	SEQUENCE							
Perform print quality checks, sheet 2 of this DDLT.	X	-	-	-	-	-	-	-
Perform carriage return LED adjustment, procedure NIP6.	-	-	5	-	1	-	-	-
Perform printhead actuation adjustment, procedure NIP7.	-	5	-	-	-	-	-	-
Check fuse at rear of unit.	-	-	-	-	-	-	1	-
Check power available from site outlet.	-	-	-	-	-	-	2	-
Remove cabinet top and check internal cable connections.	-	-	-	-	-	-	3	-
Check power ON switch (continuity check with ac power cord disconnected from site outlet).	-	-	-	-	-	-	4	-
Replace power supply, procedure NIP12.	-	-	-	-	-	-	5	-
Check I/O cable connections at printer and other end.	-	1	1	1	-	-	-	-
Replace printer interface board 04B, procedure CRT8.	-	3	3	3	-	-	-	-
Check serial input clock timing, procedure NIP10.	-	4	4	4	-	-	-	-
Replace print mechanism, procedure NIP11.	-	6	6	5	2	X	-	-
Check seating and switch settings of printer interface board 04B in display logic module (table CRT8).	-	2	2	2	-	-	-	-
Call next level of support.	-	-	-	-	-	-	-	X
Note: After completing any repairs or maintenance, verify that the printer is operational by rerunning Subsystem Test Section 6.								

TABLE NIP1. DDLT FOR NONIMPACT PRINTER (SHEET 2 OF 2)

PRINT QUALITY CHECKS							
ASSUME							
Printer operation checks per sheet 1 of this DDLT completed.							
CONDITIONS	SITUATIONS						
	1	2	3	4	5	6	7
Is horizontal character spacing correct?	Y	Y	Y	Y	Y	N	O
Is printing dark enough across entire page?	Y	Y	Y	Y	N	-	T
Is print density even across page?	Y	Y	Y	N	-	-	H
Is print density even from top to bottom of characters?	Y	Y	N	-	-	-	E
Does the printhead move steadily (not oscillate) during print operations?	Y	N	-	-	-	-	R
ACTIONS	SEQUENCE						
Nonimpact printer checks OK. Press 9 key (or any other alphanumeric) to exit printer test. If entered this table from Test section 2 of table CRT1, while performing keyboard display terminal checkout, return to table CRT1 at sheet 5. If checking NIP only, task is done.	X	-	-	-	-	-	-
Perform head compensation adjustment, procedure NIP5.	-	-	-	-	1	-	-
Perform printhead actuation adjustment, procedure NIP7.	-	-	1	1	2	-	-
Perform retriggerable OS adjustment, procedure NIP3.	-	-	-	-	-	1	-
Check 1-kc oscillator time, procedure NIP2.	-	-	2	2	3	-	-
Perform brake LED and one-shot adjustment, procedure NIP4.	-	1	-	-	-	-	-
Replace print mechanism, procedure NIP11.	-	2	3	3	4	2	-
Call next level of support.	-	-	-	-	-	-	X
Note: After completing any repairs or maintenance, verify that the printer is operational by rerunning Subsystem Test Section 6.							

Nonimpact Printer Corrective Maintenance Procedures — General

Following pages contain all of the procedures that are referenced either from table NIP1, DDLT for Nonimpact Printer, or from elsewhere within this manual. In addition, other procedures which may serve useful (NIP8 and 9) are provided.

Parts replacement level for the nonimpact printer is to the printer mechanism (including circuit cards), power supply assembly, fuse, and printer interface control board in the display terminal. Keep in mind that if a procedure allows a lower level of replacement than the standard on-site spare parts list (provided in section 8, volume 1), or calls for adjustments more detailed than it may be able to perform on site because of limited equipment/or facilities — then it is at the discretion of the customer engineer to simply replace the problem area the next highest level spare part/assembly which is available and expedient.

WARNING

Any time the NIP cabinet hood is removed, if it is necessary to work near the exposed underside of the power ON switch or near any of the ac input power lines, always shut power off and disconnect ac power cord from site power outlet.

Procedure NIP1 — Paper Loading and Power On

Select paper as recommended under the heading Nonimpact Printer Paper at the end of this procedure, and perform the following steps:

- 1) See that printer power ON switch is not lit (press to turn off).
- 2) Open paper cover by pressing at rear of cover.
- 3) Remove paper spindle by lifting straight up.
- 4) Remove old paper core and install new paper roll on spindle.
- 5) Set paper roll behind printer, lift paper rod and thread paper around paper rod and between paper guides (see figure NIP1).
- 6) Feed paper through printer by turning paper feed roll by hand.

- 7) Roll up slack and replace spindle and paper in the paper roll slot of printer.
- 8) Close paper cover.
- 9) Press printer power ON switch so it lights indicating power on.
- 10) Press the LF (line feed) switch to assure that the paper is feeding properly.

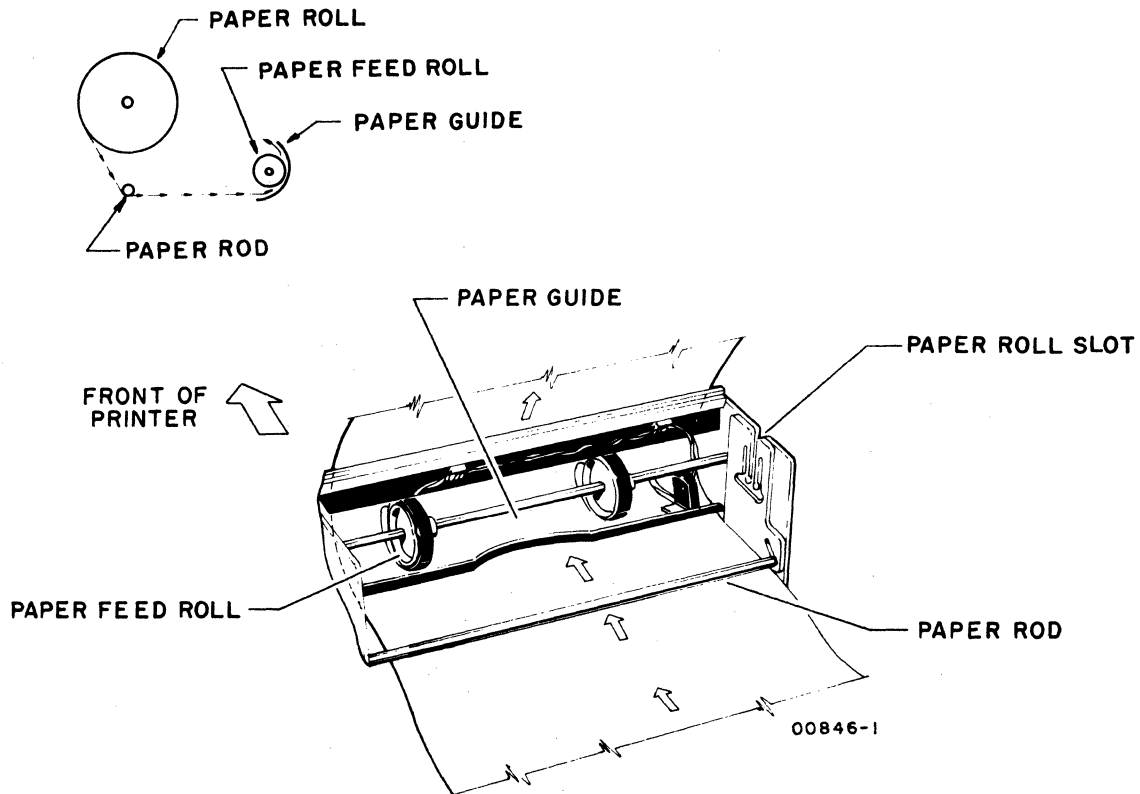

Figure NIP1. Paper Loading, Nonimpact Printer

Nonimpact Printer Paper

The nonimpact printer uses continuous-roll, thermal-sensitive paper for printing. Recommended paper is white background with blue print. This paper is available in 100-foot (30.5m) rolls in cartons of 24 rolls (CDC part number 90500521 for a full carton).

Procedure NIP2 — 1-kHz Oscillator Adjustment

The 1-kHz oscillator clocks the counter which controls the printer operation timing. Therefore, it is important to ensure that the frequency output is correct. See figure NIP2 for 1-kHz oscillator location and proceed as follows.

- 1) Connect all power to the printer.
- 2) Connect oscillator probe to 1-kHz test point at front of control logic board.
- 3) Check frequency of oscillator. Frequency must be 1-kHz $\pm 2\%$ (1 ms ± 0.02 ms per cycle).
- 4) If adjustment is required, adjust 1-kHz oscillator potentiometer on control logic board to obtain required frequency.

Procedure NIP3 — Retriggerable One-shot (ROS) Adjustment

During a carriage advance or backspace operation, ROS time is used to reduce the stepping motor winding current to a lower hold level after stepping and braking have occurred. If the ROS time is too short, horizontal print spacing can be affected. During the slowdown portion of the carriage return time, the ROS time determines the time between stepping pulses. Therefore, the slowdown of the printhead during carriage return is affected by ROS timing. See figure NIP2 for one-shot location and proceed as follows.

- 1) Connect oscilloscope probe to ROS test point at front of control logic board.
- 2) Connect all power to printer.
- 3) Use Test Section 6 of the Subsystem Test Mode Diagnostic to apply input data codes which cause 79-column printing.
- 4) ROS must be a 10-ms pulse for every carriage advance step.
- 5) Adjust ROS potentiometer on logic control board to obtain the proper pulse duration.

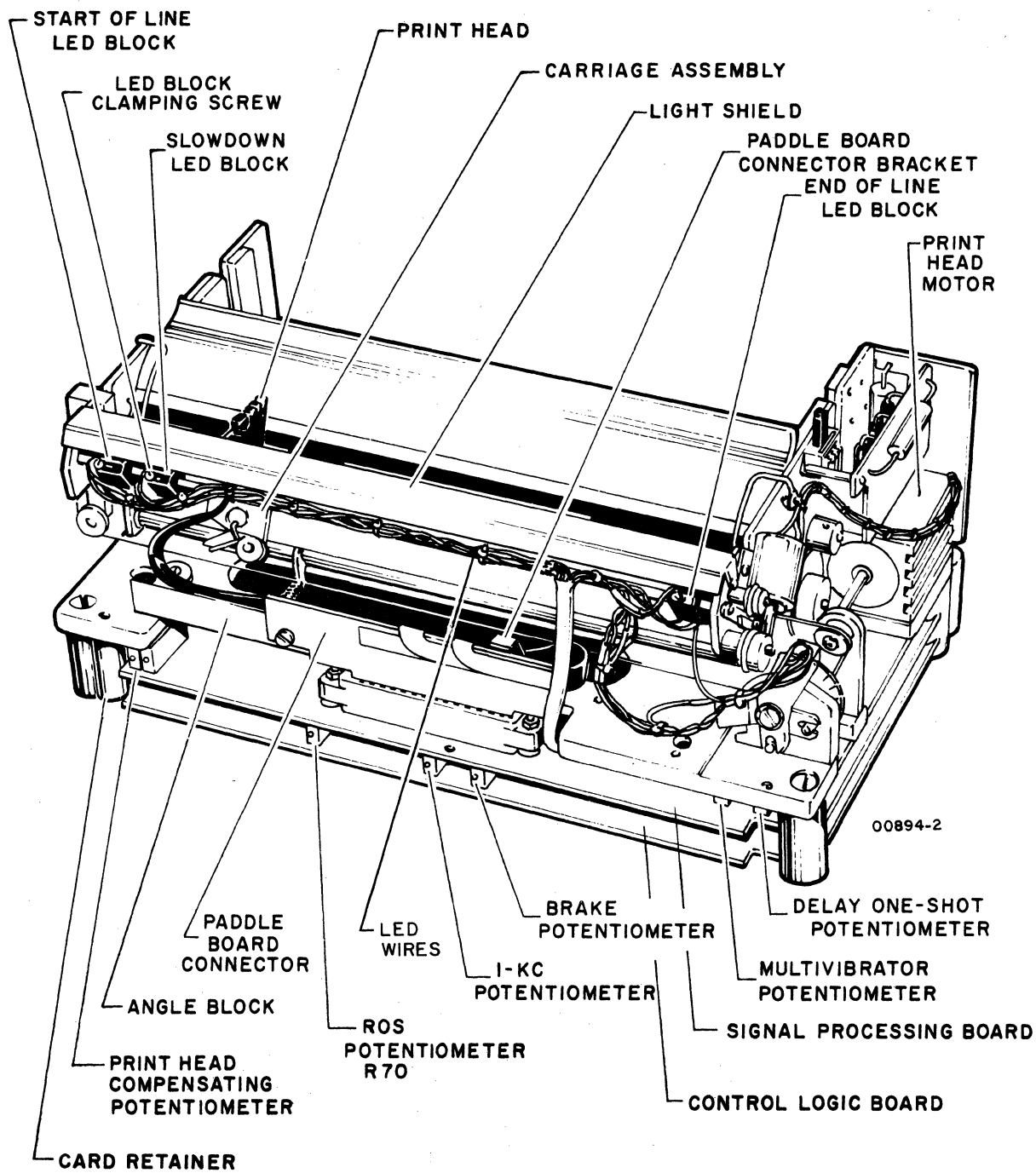

Figure NIP2. Printer, Front View

NOTE

When NIP cabinet hood is removed as in figure NIP2, check for the possibility of wires from the LED blocks shorting to the front light shield. Wire shorts here may be the cause of those seemingly insolvable intermittent printer problems. To prevent the wires from shorting, add either a couple of layers of electrical tape around and down the length of wires, or add a strip of caterpillar grommet (part number 00845501) approximately 9 inches long, along the sharp edge of the shield. Use RTV (part number 18440201) or similar adhesive to hold the caterpillar grommet in place.

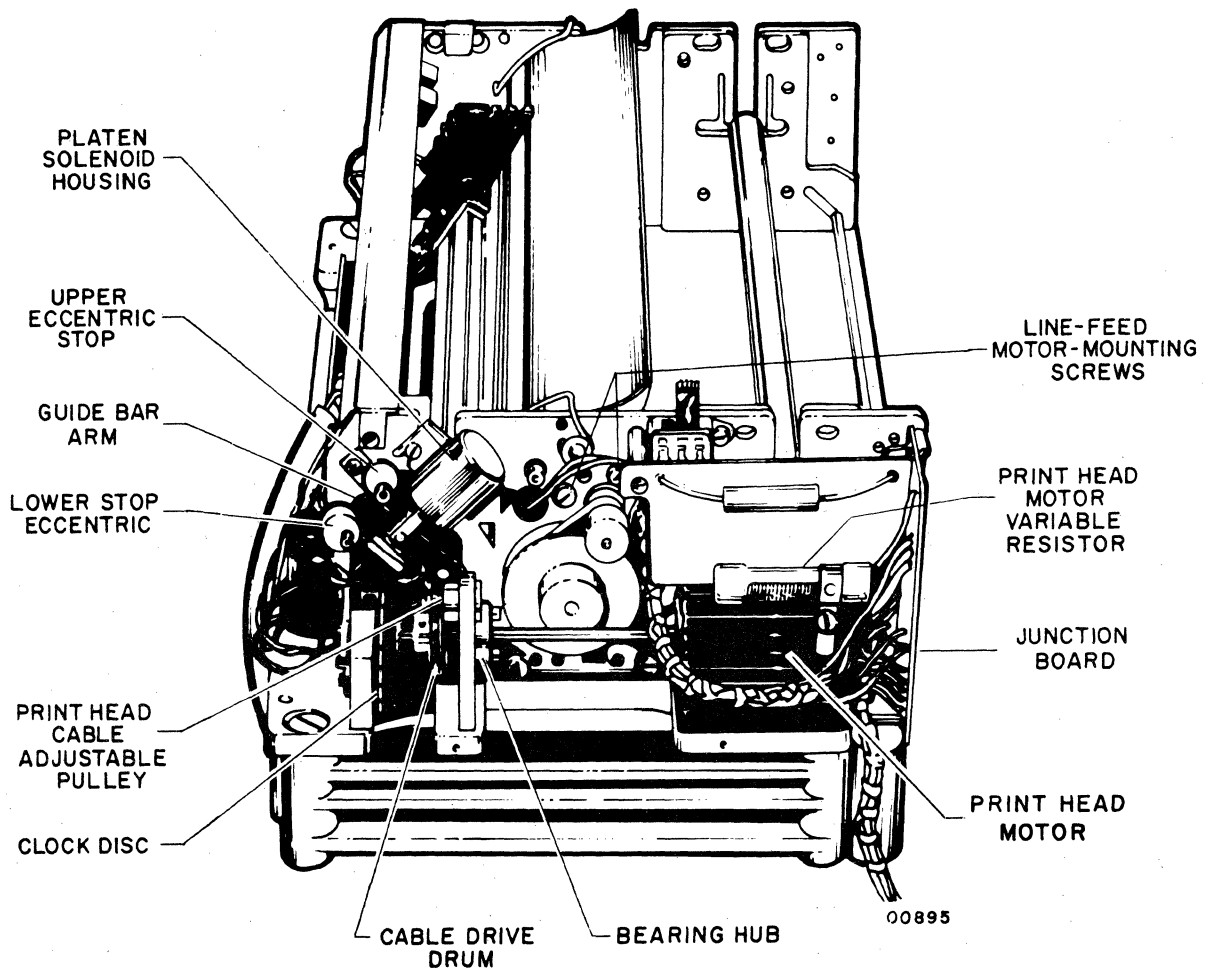

Figure NIP3. Printer, Right Side View

Procedure NIP4 — Brake LED Block and Brake One-Shot Adjustment

During carriage advance and backspace operations, the printhead is brought into contact with the paper by the platen solenoid, printing occurs, the printhead is moved back from the paper, and then the stepping motor moves the head to the next column position. For proper printing, the printhead must be horizontally stationary at each column position when printing at maximum speed. Oscillations of the printhead cannot be tolerated since print quality would be affected. Oscillations can be caused by improper position of the brake LED block or improper setting of the brake one-shot time. Motor braking is initiated by the brake LED and its duration is controlled by the brake one-shot time. In this procedure, a visual check of the clock disc is made to determine if oscillations are present. The platen solenoid is disabled because oscillations would be damped by the head contacting the platen. (See figures NIP 3 and NIP5).

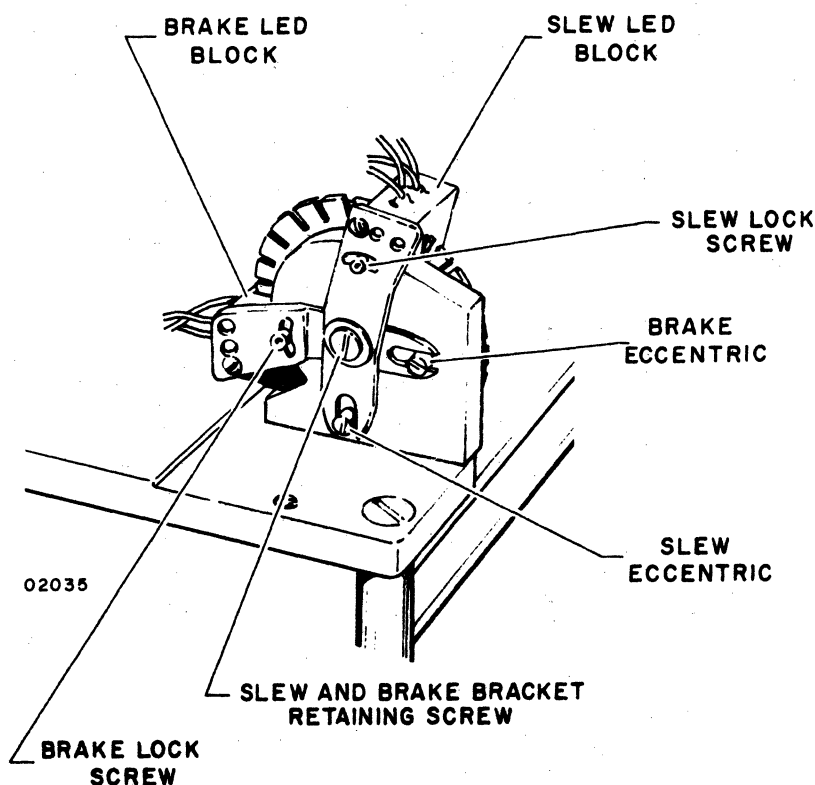

Figure NIP4. Printer, Right Front View

- 1) Disable platen solenoid by holding finger on platen solenoid guide bar arm to prevent solenoid operation.
- 2) Connect all power to the printer.
- 3) Use keyboard of terminal subsystem to cause repetition of carriage advance for approximately 60 columns followed by backspaces for approximately 60 columns.
- 4) Observe top of brake LED block in relation to clock disc. Block should be aligned with a slot in clock disc and disc must appear to stand still (no oscillating) for both carriage advance and backspace. If adjustment is required, perform steps 5 through 7.
- 5) Loosen one (center) slotted-head screw that secures brake and slew LED brackets.
- 6) Loosen one socket-head lock screw to permit adjustment of brake LED block position.
- 7) Alternately adjust brake LED block position and brake one-shot time, until conditions of step 4 are obtained. Adjust brake LED block position by turning slotted-head eccentric. Adjust brake one-shot time by adjusting brake potentiometer at front of control logic board (figure NIP2). Tighten screws.

NOTE

If difficulty occurs in damping out oscillations, check oscillation of printhead cable. If cable oscillates more than 1/4 inch, replace entire print mechanism (procedure NIP11). If oscillation is less than 1/4 inch, recheck ROS time as outlined in procedure NIP3. If oscillations still are present check output of brake LED. See procedure NIP2.

Procedure NIP5 — Head Compensating Circuit Adjustment

The purpose of this circuit is to control the heating time of the printhead elements. The heating time is automatically varied by the circuit to compensate for different printing speeds. The purpose of this procedure is to provide an initial setting of the circuit time when printing at maximum speed. Then, when the printer is operable, the time may be readjusted to provide desired print quality. See figure NIP2 and proceed as follows.

- 1) Apply all power to printer.
- 2) Connect oscilloscope probe to test point PRT at front of signal processing board. Trigger internal (+).
- 3) Use Test Section 6 of the Subsystem Test Mode Diagnostic to apply input data codes which cause 79-column printing.
- 4) The output transistor must turn on for the time indicated below for the particular speed at which the printer is to be operated. Adjust head compensating potentiometer on signal processing board to obtain a pulse duration of 6.5 ms.
- 5) Secure potentiometer screw with cement (Loctite, or equivalent).
- 6) When printer is operable, check print quality. If quality is not acceptable, refer to procedure NIP8, Print Quality Adjustments.

Procedure NIP6 — Carriage Return LED Block Adjustment

This procedure describes adjustments for the positions of the LED blocks associated with carriage return. These LEDs are start-of-line, slowdown, end-of-line, and slew. The LEDs are positioned to provide carriage return operation within the maximum time permissible (200 ms) and minimize printhead oscillation at column 1. This procedure should be performed when any of the carriage return components have been replaced or when any of the LED block positions have been changed. See figure NIP2 and proceed as follows.

- 1) Loosen the LED block clamping screw on each of the start-of-line, slowdown, and end-of-line LED blocks.
- 2) Set the initial positions of the three LED blocks as follows:
 - a) Position left side of start-of-line LED block $7/16$ inch from left side frame.
 - b) Position slowdown LED block until spacing between start-of-line block and slowdown block is $5/16$ inch.
 - c) Position right side of end-of-line LED block $3/16$ inch from right side frame.
- 3) Connect all power to the printer.
- 4) Manually move printhead to approximately column 15 and initiate a discrete carriage return operation.

NOTE

A discrete carriage return operation can be initiated by pressing the CR switch.

- 5) Measure distance between printhead carriage and left side frame. Distance should be $3/16$ inch (see figure NIP5).

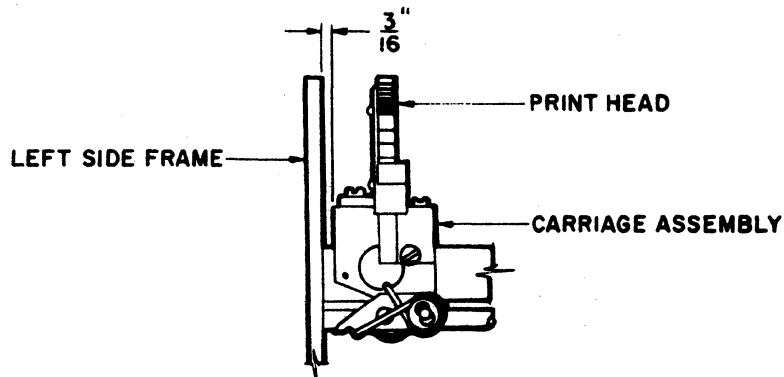

Figure NIP5. Printhead Home Position

- 6) If adjustment of printhead home position is required, loosen two socket-head screws in cable drive drum (figure NIP3) and rotate drum until printhead is 3/16 inch from left side frame. Tighten screws.
- 7) Move printhead to approximately column 60 and initiate a discrete carriage return operation. For this step the carriage return command must be maintained, i.e., hold CR switch down.
- 8) If printhead oscillates at home position, move start-of-line LED block left or right in small increments (approximately 0.001 inch) until head stops oscillating.
- 9) Release CR switch.
- 10) Repeat steps 7 through 9, except start with printhead at a column near column 80, e.g., 75 to 79.
- 11) With keyboard display and printer connected and with subsystem power on, use the keyboard to cause printhead to step to column two. Actuate a discrete carriage return. If printhead does not return to column one, move start-of-line LED block to the left in small increments (approximately 0.001 inch) until carriage return from column two is achieved.
- 12) If start-of-line LED block was moved in step 11, repeat steps 7 through 10. If start-of-line block is again moved to stop oscillations, repeat step 11.
- 13) Trigger oscilloscope on CR test point at front of control logic board (figure NIP2) and set trigger to external (+). Connect oscilloscope probe to SD test point.
- 14) Use Test Section 6 of the Subsystem Test Mode Diagnostic to cause continuous printing and automatic carriage return by the end-of-line LED.
- 15) Measure time between oscilloscope trigger (rise of CR) and rise of SD. Time must be 110 ± 5 milliseconds.
- 16) If adjustment is required, loosen one (center) slotted-head screw and one socket-head screw to permit adjustment of slew LED block. (See figure NIP5.) Turn slotted-head eccentric and adjust slew block position until requirement of step 15 is met. Tighten two screws.

NOTE

In the process of adjusting the slew LED block, the block should not be positioned at the extreme left. If positioned to the extreme left, the slew block may be in contact with the eccentric adjustment of the platen solenoid arm. Repositioning the clock disc will center the adjustment and provide future adjustment range without mechanical interference.

To reposition the clock disc, loosen the clock disc set screws, and with the motor shaft held stationary (by holding the printhead), move the clock disc by a one-half slot separation and then tighten, ensuring that the disc does not rub the brake or slew blocks. Readjust the brake and slew (step 16) blocks for proper printer operation.

- 17) Trigger oscilloscope on SD test point on control logic board and set trigger to external (-). Connect one oscilloscope probe to SD test point.
- 18) Use keyboard of connected keyboard display to step printhead from column 1 to column 6. SD should fall as printhead steps into column 6. Adjust position of slowdown LED block to meet this condition.
- 19) Use Test Section 6 of the Subsystem Test Mode Diagnostic to cause continuous printing and automatic carriage return by end-of-line LED.
- 20) Trigger on CR test point (+ trigger), and look at SD with the probe. Recheck the CR time from EOL to SD at step 15. Adjust the slew if this condition is not met. On printers with adjustable home position (HPOS) time, HPOS should be set for 40-60 ms. Be sure that a slew pulse does not occur close to the leading edge of the SD phototransistor pulse.

NOTE

The 40-60 ms is only a guide and should not be used as a criterion for rejection. The objective is to arrive at CR time of 160 to 185 ms when warmed-up and an absolute maximum of 200 ms when cold.

Final position of slowdown block should be such that the nominal distance between slowdown and start-of-line blocks is $5/16 \pm 1/16$ inch. (This criterion is included as a guide; note that this is only a nominal value.)

- 21) Insert paper in printer.
- 22) Trigger oscilloscope on \overline{MT} test point and set trigger to external (-). Connect one oscilloscope probe to \overline{MT} test point and second probe to EOL test point.
- 23) Use Test Section 6 of the Subsystem Test Mode Diagnostic to cause continuous printing and automatic carriage return by end-of-line LED.
- 24) Adjust position of end-of-line LED block so that rise of EOL comes within one millisecond after rise of \overline{MT} for column 80. Make sure column 80 print is present.
- 25) Trigger oscilloscope on CR test point and set trigger to external (+). Connect oscilloscope probe to BSY test point.
- 26) Use Test Section 6 of the Subsystem Test Mode Diagnostic to cause continuous printing and automatic carriage return by end-of-line LED.
- 27) Measure time that BSY stays true after CR trigger. Time should be 150 to 175 milliseconds (200 milliseconds maximum). If this requirement is not met, repeat steps 13 through 16, and 17 through 20.
- 28) Tighten all LED block clamping screws.

Procedure NIP7 — Printhead Actuation Adjustment

This procedure contains instructions for adjustment of the printer to obtain proper printhead actuation and noise control. The platen solenoid housing must be positioned to prevent plunger bottoming and to ensure free plunger movement. The upper eccentric stop is adjusted to absorb some of the impact as the printhead contacts the paper. Uniform print density from top to bottom of a character and across the entire line is obtained by adjustment of the platen assembly. The lower eccentric stop is adjusted to provide proper guide bar arm travel between the two stops. The damper pad is adjusted to contact the solenoid plunger and reduce noise without restricting the plunger movement. (See figures NIP3, 6, and 7.)

- 1) Disconnect all power and signal inputs to the printer.
- 2) Remove paper. If switch bracket is in the way, remove two screws and move bracket out of way.

- 3) Move plunger into platen solenoid housing until printhead just contacts rubber platen. Check to see that after head contacts platen, plunger can be pushed approximately 1/32 inch into housing and does not bind. If adjustment is required, perform steps 4 through 6.
- 4) Loosen two slotted-head screws which mount the platen solenoid housing to the frame.
- 5) Manually move printhead down until it just contacts platen and hold it in this position. Move solenoid housing until plunger bottoms. Mark solenoid housing position on side frame. Release printhead. Move solenoid housing back approximately 1/32 inch from mark on frame. Tighten two screws.
- 6) Check to see that plunger moves freely in housing and does not bind. If binding occurs, loosen two screws and skew housing until plunger is free. Make sure that 1/32-inch dimension obtained in step 4 is maintained.
- 7) Insert paper. Connect power and signal inputs to the printer and use Test Section 6 of the Subsystem Test Mode Diagnostic to print several lines.
- 8) Check print density from top to bottom of character. If density varies, perform step 9. If density is uniform, proceed to step 10.
- 9) Loosen four socket-head screws (two on each side) securing platen assembly to side plates. Tilt assembly forward or backward to obtain uniform print density from top to bottom of character. Tighten four screws. Recheck print density.
- 10) While printing, place a 0.010-inch feeler gauge between upper eccentric stop and guide bar arm. If upper eccentric stop is properly adjusted, print quality should deteriorate significantly when gauge is inserted. If adjustment is required, perform step 11. If adjustment is correct, proceed to step 12.
- 11) Loosen one socket-head screw to permit rotation of upper eccentric. Rotate eccentric in counterclockwise direction until print becomes light. Back off eccentric just enough to restore good quality print. Repeat step 10.
- 12) If print density varies from left to right across the page, it is necessary to reposition the platen assembly. Loosen two socket-head screws securing side of platen assembly where light printing is occurring and move this side of assembly forward to obtain uniform print density. Tighten screws. Recheck step 10.

NOTE

When moving platen assembly, take care not to tilt assembly. Tilting will affect print quality.

- 13) Disconnect all power and signal inputs to the printer.
- 14) Using a feeler gauge, check the clearance between the upper stop eccentric and the guide bar arm. The clearance must be 0.020 to 0.025 inch (see figure NIP6). If adjustment is required, loosen one socket-head screw to permit rotation of lower stop eccentric. Place a 0.022-inch gauge between the guide bar arm and upper stop eccentric. Rotate lower stop eccentric until contact is made between guide bar arm, gauge, and upper eccentric. Tighten screw.

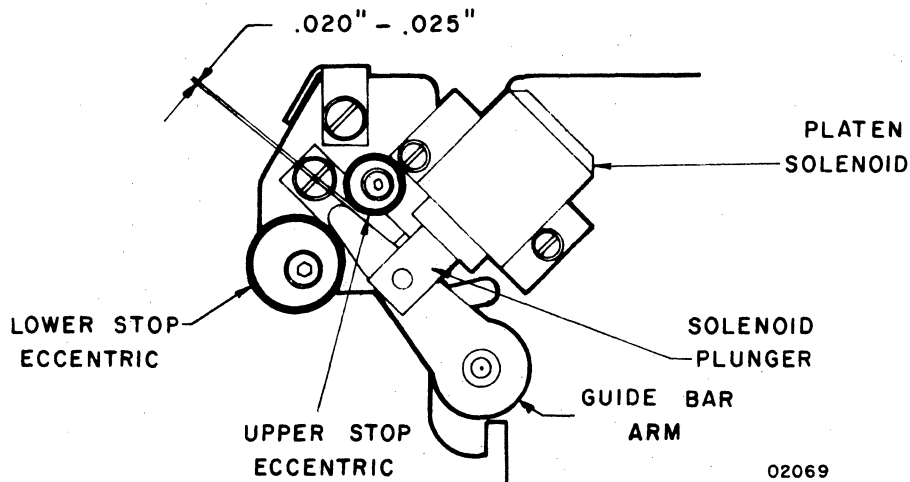

Figure NIP6. Guide Bar Arm Travel

- 15) Connect all power and signal inputs to the printer and use Test Section 6 to again cause printing.
- 16) Check print quality. If print has a dark cast or printhead drags on paper during carriage return, the solenoid plunger damper pad may be adjusted too tight, restricting solenoid plunger movement. If print quality is good, but vibration and noise is discernible, the damper pad may be adjusted too loose. Loosen locknut and turn damper pad adjusting screw to increase pad pressure until print quality is affected. Then back off screw just enough to obtain good print quality. Tighten nut (see figure NIP7).

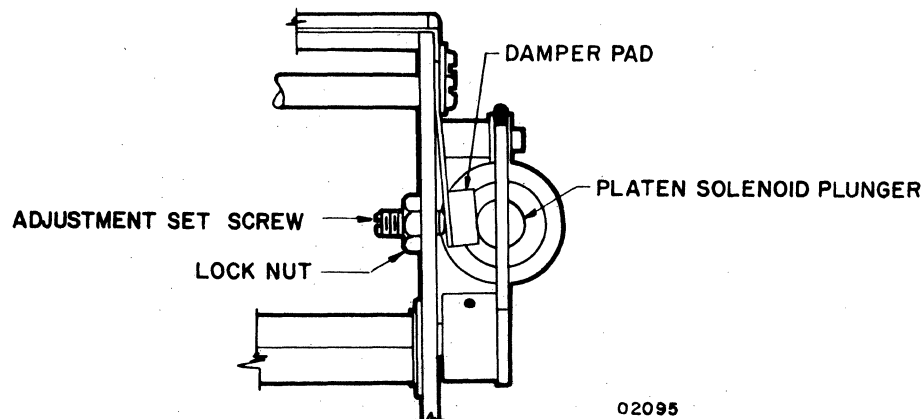

Figure NIP7. Damper Pad Adjustment

Procedure NIP8 — Print Quality Adjustments

Table NIP2 lists the different types of poor print quality and references the adjustment procedures which can be performed to correct the problem.

TABLE NIP2. PRINT QUALITY

PROBLEM	ADJUSTMENT PROCEDURE
Too light across entire page	NIP5, Head Compensating Circuit Adjustment NIP7, Printhead Actuation Adjustment
Uneven density across page	NIP7, Printhead Actuation Adjustment
Uneven density from top to bottom of character	NIP7, Printhead Actuation Adjustment

Procedure NIP9 — Out-of-Paper Switch Adjustment

The out-of-paper switch must be adjusted to actuate when paper is inserted in the printer and deactuate when paper is removed. Adjustment is accomplished by positioning the switch. See figure NIP8 and proceed as follows.

- 1) Remove paper from printer.
- 2) Slowly insert paper into printer while listening for switch to actuate. An ohmmeter may be used in a noisy environment.
- 3) After switch actuates, observe actuator arm to ensure that some over-travel is present.
- 4) Slowly remove paper while listening for switch to deactuate.
- 5) After switch deactuates, observe actuator arm to ensure that some over-travel is present.
- 6) If adjustment is required, loosen two switch-mounting screws on left side frame and position switch to meet requirements of steps 3 and 5. Tighten screws and repeat steps 2 through 5.
- 7) Connect power to printer and check ready output line at pin 36 of input/output connector P37. Voltage should be +5 volts with paper inserted and 0 volts with paper removed.

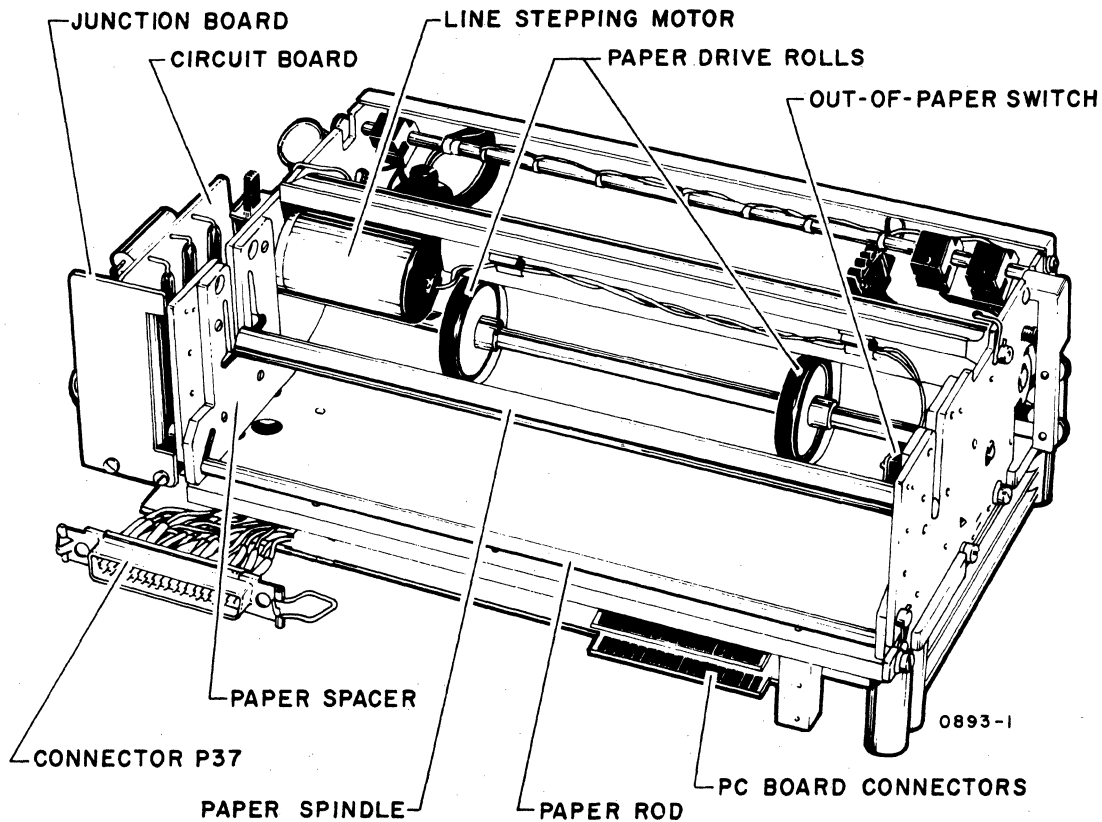

Figure NIP8. Printer, Rear View

Procedure NIP10 — Serial Input Clock Adjustment

The serial input clock must be adjusted so that it occurs as close as possible to the center of each data bit time. This provides tolerance for input signal distortion. There are two interacting adjustments required to properly position the clock pulses: (1) delay one-shot time and (2) multivibrator frequency. The delay one-shot time determines the position of the first clock at data bit one time. The multivibrator frequency determines the position of the subsequent clock pulses. See figures NIP2 and NIP9 and proceed as follows.

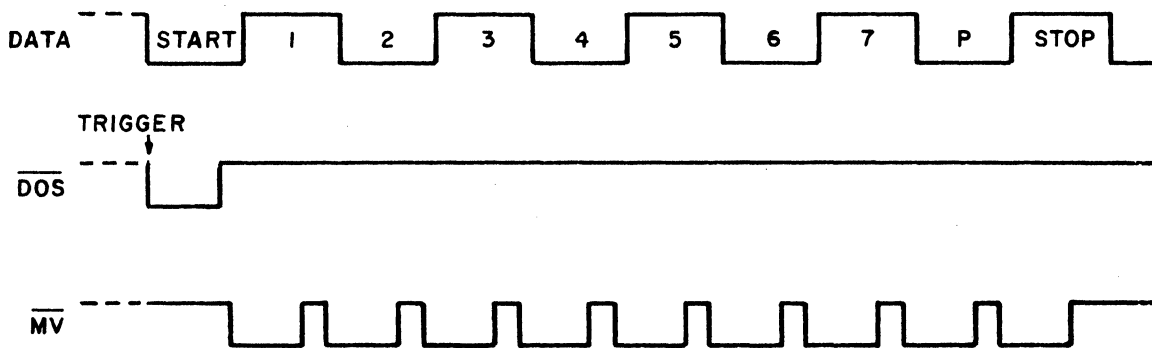

Figure NIP9. Serial Clock Timing

- 1) Connect all power to the printer.
- 2) Using a dual trace oscilloscope, trigger the oscilloscope on the falling edge of \overline{DOS} (test point OS at front of signal processing board).
- 3) Set the oscilloscope time base to display one character time.
- 4) Apply an input signal from a square wave generator set to the baud rate of the printer or apply an input code consisting of alternating 101's.
- 5) Connect one probe of the oscilloscope to the DATA test point.
- 6) Connect the other probe to \overline{MV} (CK test point).
- 7) Check the clock position (rise of \overline{MV}) for data bit one time. If the clock is not centered, adjust the one-shot potentiometer.
- 8) Check the clock position for the last data bit time. If the clock is not centered, adjust the multivibrator potentiometer.
- 9) If the oscilloscope has a 5X magnifier, turn on the magnifier and repeat step 7.
- 10) Move the trace to the left and repeat step 8.

NOTE

Steps 7 and 8 should be repeated several times because of the interaction of the two adjustments.

Procedure NIP11 — Replacing Print Mechanism

Perform the following steps to replace the print mechanism (see figure NIP10).

- 1) Remove ac power cord from site outlet.
- 2) Disconnect internal connector which is on end of printer mechanism signal cable and is located at back of power supply just above RS-232-C I/O connector.
- 3) Tilt printer cabinet up on either left or right side and loosen the four, large, shock-mounting retainer screws which hold the print mechanism to the chassis base and are accessible through four large, round holes in the base of the cabinet.

CAUTION

Do not tilt printer cabinet up on its back with an I/O connector attached to the rear of the cabinet or serious connector damage will result.

- 4) While holding print mechanism so it does not fall, remove the four retainer screws and separate mechanism from cabinet base. Carefully lower cabinet base and print mechanism to normal resting position.

NOTE

An alternate removal method is to remove the four hex nuts (and washers) that secure the metal baseplate under the printer mechanism. Two of these nuts are at the front corners of the mechanism and the other two also hold the power supply shield. This method then requires removing the mechanism from the baseplate.

- 5) Replace print mechanism by doing the preceding steps in reverse order (making sure mechanism is approximately centered in its mounting slots) and then check operation thoroughly by following table NIP1, DDLT for Nonimpact Printer.

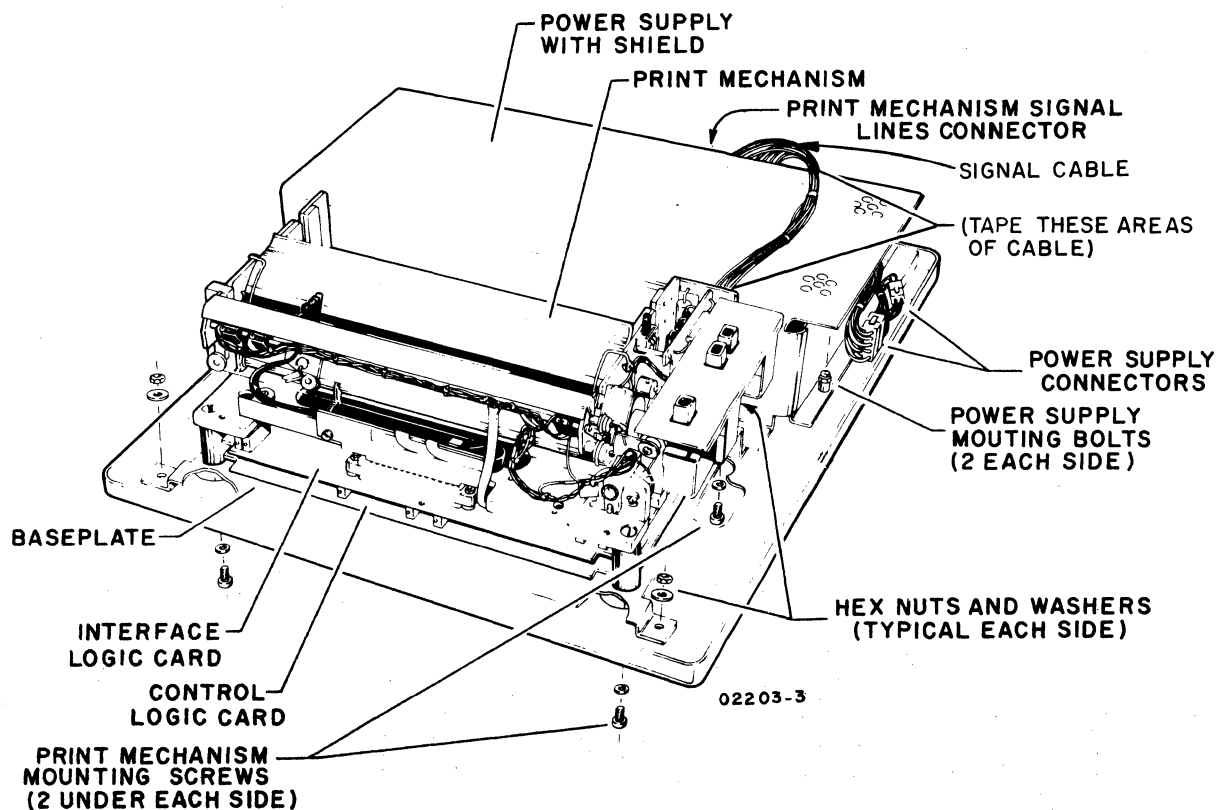

Figure NIP10. Location of Major Replaceable Modules

Procedure NIP12 — Replacing Power Supply

Perform the following steps to replace the power supply (see figure NIP10).

- 1) Remove ac power cord from site outlet.
- 2) Disconnect both quick-disconnect connectors from cable at right side of power supply.
- 3) Remove two nuts which hold power supply shield in place (screws are on cover flange between power supply and print mechanism) and lift cover free to provide clearance for power supply removal.
- 4) Unscrew four large screws (2 each side) from power supply mounting flanges and slide power supply out from under print mechanism cable.

- 5) Check the signal cable routed over the power supply. It is subject to damage by sharp edges of power supply shield. If ok, protect cable from future damage by covering areas of cable exposed to sharp edges with electrical tape or similar protective covering.
- 6) Replace power supply by doing the preceding steps in reverse order and then check operation thoroughly by following table NIP1, DDLT for Nonimpact Printer.

Procedure NIP13 — Replacing/Adjusting Miscellaneous Parts

If required to replace/adjust parts below the on-site spares level (on-site spares being: power supply, fuses, and printer mechanism) refer to the Nonimpact Printer Hardware Maintenance Manual (see preface for publication number).

TABLE IMP1. DDLT FOR IMPACT PRINTER (SHEET 1 OF 4)

POWER ON AND EXTERNAL SWITCH CHECKS (EXCLUDING TEST PRINT)								
ASSUME								
Paper, ribbon, and format tape loaded (procedure IMP3, 4, and 5) and power ON/OFF switch pressed to ON (procedure IMP1).								
CONDITIONS	SITUATIONS							
	1	2	3	4	5	6	7	8
Is power on at printer (ON/OFF switch lit and drive motor running)?	Y	Y	Y	Y	N	N	N	O T H E R
Is motor running but switch light out?	-	-	-	-	Y	N	N	
Is ON/OFF switch lit but motor not running?	-	-	-	-	-	Y	N	
Does FORM FEED operate correctly?	Y	Y	N	N	-	-	-	
Does forms runaway condition (continuous paper feed) occur? (Stop runaway by pressing power OFF.)	-	-	Y	N	-	-	-	
Does START/STOP switch light/extinguish when pressed/re-pressed?	Y	N	-	-	-	-	-	
ACTIONS	SEQUENCE							
Perform TEST PRINT, sheet 2 of this DDLT.	X	-	-	-	-	-	-	-
Check that front access panel is in place activating interlock switch (or if front panel open, interlock switch pulled up).	-	-	-	-	-	-	1	-
Check power available from site outlet (see specifications in section 1 for 60-Hz and 50-Hz matrix printer input power).	-	-	-	-	-	-	2	-
Check ON/OFF circuit breaker indicator portion for continuity (figures IMP12 and IMP13); replace ON/OFF switch/indicator if necessary (procedure IMP17).	-	-	-	-	2	-	-	-
Check internal cables/connections (figures IMP11, 12, 13, and 14 and procedure IMP14).	-	-	-	-	1	1	4	-
Disconnect ac power cord and check power cord and ON/OFF switch for continuity; replace as necessary (procedure IMP17).	-	-	-	-	-	-	3	-
Check/replace power transformer 2T01 (procedure IMP17).	-	-	-	-	3	2	6	-
Check/replace line filter 3LF01 (procedure IMP17).	-	-	-	-	-	3	5	-
Check/replace drive motor (procedure IMP17).	-	-	-	-	-	4	7	-
Check/replace format tape (procedure IMP5) and format reader (procedures IMP15 and IMP17).	-	-	1	1	-	-	-	-
Open logic chassis panel (procedure IMP6) and observe printed circuit boards for proper seating (figure IMP6).	-	1	2	2	-	-	-	-
Check/replace fuse(s) on power supply board (procedure IMP12); replace power supply board (procedure IMP7).	-	-	3	3	-	-	-	-
Check/replace fuse(s) on driver board (procedure IMP12); replace driver board if required (procedure IMP9).	-	-	-	4	-	-	-	-
Replace common controller board (procedure IMP7).	-	2	-	5	-	-	-	-
Replace RS-232 interface board (procedure IMP7).	-	-	-	6	-	-	-	-
Switch power OFF and check subject switch for continuity; replace if required (procedure IMP17).	-	3	4	7	-	-	-	-
Check subject switch cables/wires to/from switch and circuits (procedure IMP14).	-	4	-	8	-	-	-	-
See detailed diagrams/information in field service manual for matrix printer (see preface) and check/adjust/replace further (procedures IMP15, 16, and 17), or call Regional Tech Support.	-	5	5	9	-	5	8	-
Call next level of support.	-	-	-	-	-	-	-	X
Note: After completing any repairs or maintenance, verify that the printer is operational by activating TEST PRINT.								

TABLE IMP1. DDLT FOR IMPACT PRINTER (SHEET 2 OF 4)

TEST PRINT										
ASSUME										
Power on and external switch checks of sheet 1 of this DDLT ran OK and power is still on.										
CONDITIONS	SITUATIONS									
	1	2	3	4	5	6	7	8	9	
With START/STOP switch extinguished (offline), activate TEST PRINT switch. Does printer produce printout of Impact (Matrix) Printer TEST PRINT Pattern exactly as shown in appendix C?	Y	N	N	N	N	N	N	N	N	O T H E R
Are forms feeding correctly (by not being in runaway condition or otherwise incorrectly advancing)? (Stop runaway by pressing power OFF.)	Y	N	N	Y	Y	Y	Y	Y	Y	
Is printhead movement correct?	Y	N	-	N	Y	Y	Y	Y	Y	
Is there any printout?	Y	N	-	-	N	Y	Y	Y	Y	
Are all portions of all characters printed?	Y	N	-	-	-	N	Y	Y	Y	
Is each character printed the proper one?	Y	N	-	-	-	-	N	Y	Y	
Is ribbon advancing properly? (Ribbon will advance in either direction depending on position of reversing levers; check this.)	Y	N	-	-	-	-	-	-	N	
ACTIONS	SEQUENCE									
Perform print quality checks; sheet 3 of this DDLT	X	-	-	-	-	-	-	-	-	
Open logic chassis panel (procedure IMP6) and observe printed circuit boards for proper seating (figure IMP6).	-	1	2	1	1	1	1	1	-	
Check/replace fuse(s) on driver board (procedure IMP12), replace driver board if required (procedure IMP9).	-	2	5	2	2	2	-	-	-	
Replace common controller board (procedure IMP7).	-	3	4	-	3	3	2	-	-	
Replace LSI equivalent board (procedure IMP7).	-	-	6	3	4	-	3	-	-	
Press power to OFF and check for TEST PRINT switch continuity, replace if required (procedure IMP17).	-	4	-	-	-	-	-	-	-	
Check/replace fuse(s) in power supply board (procedure IMP12); replace power supply board if required (procedure IMP9).	-	-	3	-	-	-	-	3	-	
Check TEST PRINT switch cables/wires to/from switch and circuits (procedure IMP14).	-	5	-	-	-	-	-	-	-	
Check/replace switching relay and/or power triacs on logic chassis backplane (procedure IMP17).	-	-	-	-	-	-	-	2	-	
See detailed field service manual and parts manual (see preface) and check/adjust/replace until fault is found (procedures IMP15, 16, and 17), or call Regional Tech Support.	-	7	7	6	9	7	4	4	-	
Check/adjust/replace printhead (procedures IMP15, 16, and 17).	-	-	-	-	6	5	-	-	-	
Check/replace format tape (procedure IMP5) and format reader (procedures IMP15 and IMP17).	-	-	1	-	-	-	-	-	-	
Check cables between driver board and printhead (procedure IMP14).	-	-	-	-	5	4	-	-	-	
Replace line start board (procedure IMP10).	-	6	-	4	7	-	-	-	-	
Replace character start board (procedure IMP11).	-	-	-	5	8	6	-	-	-	
Call next level of support.	-	-	-	-	-	-	-	-	X	
Note: After completing any repairs or maintenance, verify that the printer is operational by activating TEST PRINT.										

TABLE IMP1. DDLT FOR IMPACT PRINTER (SHEET 3 OF 4)

PRINT QUALITY CHECKS											
ASSUME											
TEST PRINT operation per sheet 2 of this DDLT completed and resulting printout available for print quality analysis.											
CONDITIONS	SITUATIONS										
	1	2	3	4	5	6	7	8	9	10	
Is printing dark enough across entire page?	Y	Y	Y	Y	Y	Y	Y	Y	N		
Is printing density even for each of the seven vertical dots in the 7-horizontal by 7-vertical dot matrix of each character?	Y	Y	Y	Y	Y	Y	Y	N	-		
Are the dots which compose each character evenly spaced from each other horizontally?	Y	Y	Y	Y	Y	Y	N	-	-	O T H E R	
Are adjacent characters uniformly spaced from each other horizontally across entire page?	Y	Y	Y	Y	Y	N	-	-	-		
Is the leftmost column of characters uniformly aligned on the left margin?	Y	Y	Y	Y	N	-	-	-	-		
Are the 132 columns of characters uniformly aligned one under the other down entire page?	Y	Y	Y	N	-	-	-	-	-		
Is spacing between lines of characters even/proper down entire page?	Y	Y	N	-	-	-	-	-	-		
Are 132 characters printed in each line?	Y	N	-	-	-	-	-	-	-		
ACTIONS	SEQUENCE										
Print quality checks OK. Perform printer online checks, sheet 4 of this DDLT.	X	-	-	-	-	-	-	-	-		-
Check/adjust forms density control lever (see paper loading procedure, IMP3).	-	-	-	-	-	-	-	1	1	-	
Check for worn out ribbon and replace if necessary (see ribbon changing/loading procedure, IMP4).	-	-	-	-	-	-	-	2	2	-	
Check format tape for correct punching or for worn format tape; replace if necessary (procedure IMP5).	-	-	1	-	-	-	-	-	-	-	
Check/adjust printhead alignment with platen (procedure IMP15); replace printhead assembly if necessary (procedure IMP17).	-	-	-	-	-	-	-	3	3	-	
Check/adjust ribbon tracking (procedure IMP15).	-	-	-	-	-	-	-	4	4	-	
Check/adjust drive belts for clutch and printhead (procedure IMP15); replace if necessary (procedure IMP17).	-	3	-	1	2	1	1	-	-	-	
Check/adjust code disc assembly (procedure IMP15); replace parts if necessary (procedure IMP17).	-	-	-	2	4	2	2	-	-	-	
Check/adjust line start and character start synchronization (procedure IMP16); replace parts as necessary (procedure IMP17).	-	2	-	3	3	3	3	-	-	-	
Check/adjust format reader and paper motion system (procedure IMP15); replace parts as necessary (procedure IMP17).	-	-	2	-	-	-	-	-	-	-	
Check/adjust dashpot to prevent printhead assembly rebounding on returning home (procedure IMP15); replace worn out parts as necessary (procedure IMP17).	-	-	-	-	1	-	-	-	-	-	
Check/adjust end-of-line switch (procedure IMP15), replace parts as necessary (procedure IMP17).	-	1	-	-	-	-	-	-	-	-	
See detailed field service manual and parts manual (see preface) and check/adjust/replace until fault is found (procedures IMP15, 16, and 17) or call Regional Tech Support.	-	4	3	4	4	4	4	5	5	-	
Call next level of support.	-	-	-	-	-	-	-	-	-	X	
Note: After completing any repairs or maintenance, verify that the printer is operational by activating TEST PRINT.											

TABLE IMP1. DDLT FOR IMPACT PRINTER (SHEET 4 OF 4)

ONLINE PRINT OPERATION CHECKS (SUBSYSTEM TEST SECTION 6)			
ASSUME			
Power is on at the printer and all printer switch operations (including TEST PRINT) check OK per preceding sheets of this table. Printer I/O cable connected either to keyboard display PERIPHERAL CONNECTOR or PRINTER I/O connector on tape unit, if present (procedure TS1). Test Section 3 of table CRT1 (sheet 4) ran OK and Test Mode in display is waiting to be advanced.			
CONDITIONS	SITUATIONS		
	1	2	3
Activate PRINT ON LINE key on keyboard of keyboard display. Press spacebar twice. Does printer begin by printing a space character, continue printing a 79-character line, and continue printing successive 79-character lines in a one-character-left shifting pattern? (See Printer Diagnostic Test Pattern in appendix C.) Caution: Do not allow a printer to continuously print adjacent columns for more than 5 minutes maximum at a time or solenoid assemblies will overheat and be damaged. Press any alphanumeric key to exit this subsystem printer test.	Y	N	O T H E R
ACTIONS	SEQUENCE		
Subsystem test (Test Section 6) of printer ran OK. Printer is ready for use in subsystem. Press 9 key (or any other alphanumeric) to exit printer subsystem test. If entered this table from Test Section 2 of table CRT1, while performing keyboard display checkout, return to table CRT1 at sheet 5. If checking IMP only, task is done.	X	-	-
Check I/O cable at printer and at other end.	-	1	-
Open logic chassis panel (procedure IMP6) and observe for proper printed circuit board seating in the printer logic rack (especially check RS-232 interface board).	-	2	-
Observe for proper connections from printer logic module to I/O connector.	-	3	-
Remove RS-232 interface board (procedure IMP7), and check that all switches/jumpers are properly set for this subsystem (procedure IMP8). Reinstall RS-232 interface board (procedure IMP7).	-	4	-
Check that all switches on printer interface board 04B in display logic chassis are set properly for this subsystem (figure CRT55). Also verify this board properly seated in its rack.	-	5	-
Replace RS-232 interface board (procedure IMP7) with a new board making sure new board has proper switch/jump settings for this subsystem (procedure IMP8).	-	6	-
Replace common controller board (procedure IMP7).	-	7	-
Use table CRT8, DDLT for Printer Interface Control Function in Display Terminal and troubleshoot keyboard display connected in this subsystem. When done, return to this table.	-	8	-
See detailed field service manual and parts manual (see preface) and check/adjust/replace until fault found (procedures IMP15, 16, and 17) or call Regional Tech Support.	-	10	-
Replace LSI equivalent board (procedure IMP7).	-	9	-
Call next level of support.	-	11	-
Note: After completing any repairs or maintenance, verify that the subsystem is operational by rerunning test mode.			

Impact Printer Corrective Maintenance Procedures - General

Following pages identify all the procedures that are referenced either from table IMP1, DDLT for Impact Printer, or from elsewhere within this manual. In addition, many other procedures which may serve useful are identified. Since this impact printer has two companion manuals, in addition to this one (see preface), which cover the detailed remove/replace procedures, adjustments, and all parts data identification — wherever such procedures are identified in following pages, a reference appears to send the reader to the proper procedural details in the companion field service manual.

For the impact printer, information provided in this hardware maintenance manual, plus the detailed data in the companion field service and parts manuals, allows troubleshooting down to a very detailed level. This is in keeping with the policy of being able to perform detailed troubleshooting and repair at the customer site for medium and large printer equipments. This philosophy differs with the modular repair level approach used for small, lightweight printers such as the NIP.

Generally, it is at the discretion of the customer engineer making a service call to decide at which level adjustments or remove and replace procedures should be done for the best overall results at any particular site. This decision must take into consideration the availability of possible-required spare parts, and availability/type of test equipment and tools which are required for different level adjustment/replace procedures.

The two companion manuals already mentioned, support maintenance down to the level of internal clutch parts, printed circuit board components, and complex adjustments which require very special tools/talents. The maintenance philosophy of this hardware maintenance manual, is to limit somewhat the detailed level of maintenance for a matrix printer when used in a terminal subsystem. On the site, this means maintaining certain areas of the matrix printer at a higher level than may be possible by fully using all the information available in the manuals. Specifically, these limitations are defined as follows.

- Do not break the printhead assembly down to the solenoid level, etc., nor attempt to adjust extension of the stylus pins (print wire ends). This means do not loosen solenoid assemblies to adjust their armature position on the stylus pins. Rather, remove/replace the entire printhead assembly (procedure IMP17).
- On the hammer driver circuit board, replace fuses only (procedure IMP12), otherwise replace the whole board (procedure IMP9).
- Repair any of the four logic boards in the logic chassis only by replacing them at the board level (procedure IMP9) except for on-board fuses (procedure IMP12).
- Any/all light sensors should be replaced only at their board level, e.g., procedures IMP10 and IMP11.

Procedure IMP1 — Turning On Impact Printer Power

To turn power on the impact printer, perform the following:

- 1) Verify ac power cord connected to proper power from site outlet.
- 2) Verify paper forms installed/aligned (procedure IMP3).
- 3) Verify ribbon installed (procedure IMP4).
- 4) Verify format tape installed (procedure IMP5).

- 5) Press ON/OFF switch to ON (switch illuminates when power is on).
- 6) Press START/STOP switch to START (switch illuminates when in start condition) to place printer online with the subsystem. If offline condition desired for testing, etc., leave this switch in stop condition (not illuminated).

If desirable to check printer's operating capability, place START/STOP switch to STOP (not illuminated) and proceed as follows (if a fault should occur, start troubleshooting at table IMP1, DDLT for Impact Printer):

- 1) Press FORM FEED switch and observe that forms advance one page (as determined by a page sentinel on the format tape channel one).

NOTE

FORM FEED is inoperable when printer is in on-line condition (START/STOP switch illuminated). Also, do not activate FORM FEED switch with the format reader tape off or reader mechanism open because that causes a forms runaway condition (constant paper feeding). To stop such a runaway condition, press ON/OFF switch to OFF (extinguished), close the format reader on a format tape (procedure IMP5), and turn power switch to ON (lit) again.

- 2) Press TEST PRINT switch (illuminated) and observe that Impact Printer TEST PRINT Pattern, shown in appendix C, prints. Press TEST PRINT switch again to stop this test (switch extinguished).

NOTE

TEST PRINT switch is operable only when printer is not online (START/STOP switch extinguished), the front cover interlock switch is closed, and when no power supply faults exist. If paper forms should run out, TEST PRINT will still operate.

Procedure IMP2 — Turning Off Impact Printer Power

To turn off impact printer power, perform the following:

- 1) Press ON/OFF switch on front panel to off — it should extinguish.
- 2) If desired to remove all power applied to printer cabinet (such as for moving power supply components or just to be doubly safe when working inside cabinet), disconnect ac power cord from site outlet.

Procedure IMP3 — Installing/Aligning Paper Forms in Impact Printer

To install/align paper forms in the impact printer, use the following procedure. Select paper forms from those recommended under the heading Impact Printer Forms at the end of this procedure.

- 1) Turn printer power off (ON/OFF switch), lift front access panel slightly, slide it to front of printer cabinet, and lower access panel carefully to its open hanging position at front of cabinet.
- 2) Place stack of fanfold forms behind printer, directly below forms feed slot.
- 3) Insert top form into forms feed slot under tension bars (figure IMP1) and continue to slide form in until it is visible at front of printer.
- 4) Stand at front of printer and open left tractor flap. Position form on left tractor feed pins and close tractor flap.
- 5) Replace front access panel. Using the column guide on panel for forms position reference, slide left tractor for desired left margin on paper (tractors have fairly stiff friction clamps which require firm pressure to release).
- 6) Open right tractor flap, slide right tractor as necessary to left or right so tractor feed pins fit in right side feed holes of taut, non-skewed paper form, and close right tractor flap.
- 7) Set Forms Density Control lever according to forms thickness. Move lever toward rear of cabinet for thicker, multiple-part forms and toward front for thin forms. After starting printing, adjust this lever for best print quality.
- 8) Turn printer on and activate FORM FEED switch to position format tape reader at top of forms position.

- 9) While pressing Clutch Retractor Lever, use Forms Positioning Knob to advance form to intended first line of print (directly under printhead's present position).
- 10) Release Clutch Retractor Lever. Forms should be ready for printing.

Impact Printer Forms

Impact printers use fanfolds forms that have sprocket drive holes along each side. For best print quality and printer operation, the forms and ribbons used in impact printers should meet the following general requirements.

The printer will handle standard continuous forms paper with feed holes on each edge, with or without marginal perforations.

The forms may be from 4 to 16-3/4 inches (10.16 to 42.5 cm) in width including margins, and 3-1/2 to 18 inches (8.89 to 45.72 cm) long from fold to fold. When using the output paper basket, the forms length is limited to 11 inches (27.94 cm) from fold to fold.

The forms must have sprocket holes punched along both margins 25 ±.03 inch (63.5 ±.076 cm) from the paper edge to the hole center lines. The distance between hole center lines must be .500 ±.005 inch (1.27 ±.013 cm) nonaccumulative, and the diameter of the holes should be .156 ±.010 inch (.396 ±.025 cm). Multiple part forms must be suitably fastened with nonmetallic fasteners. The following list specifies the recommended forms in terms of parts and weights.

Parts	White Sulphite Bond Paper	Carbon Paper
1	15 pound continuous bond (56 g/m ²)	
1	24 pound continuous bond (90 g/m ²)	
2 and 3	12 pound continuous bond (45 g/m ²)	8 pound (14 g/m ²)
2 and 3	15 pound continuous bond (56 g/m ²)	8 pound (19 g/m ²)
4 and 5	12 pound continuous bond (45 g/m ²)	6 pound (14 g/m ²)

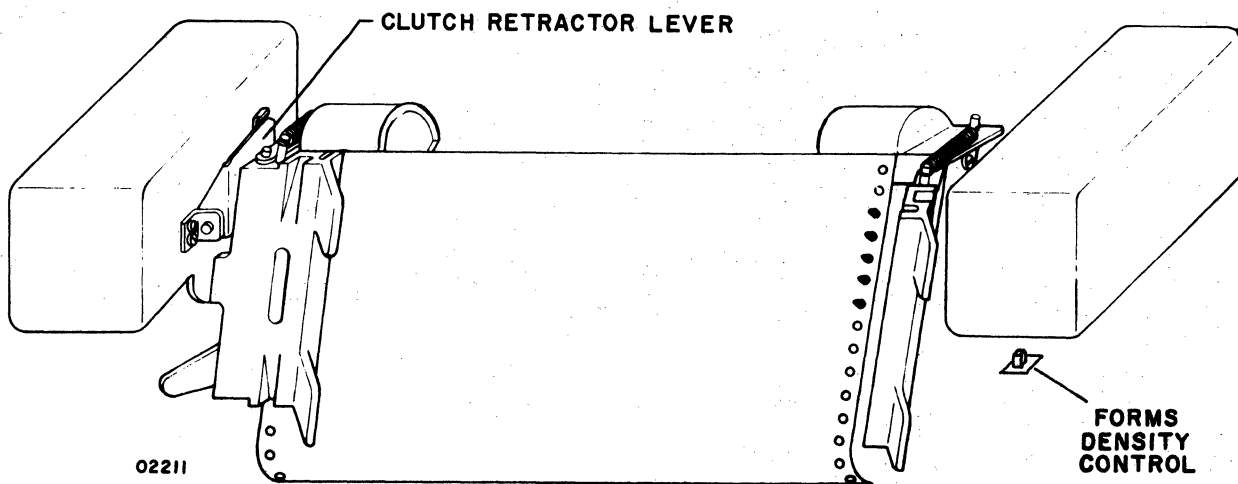
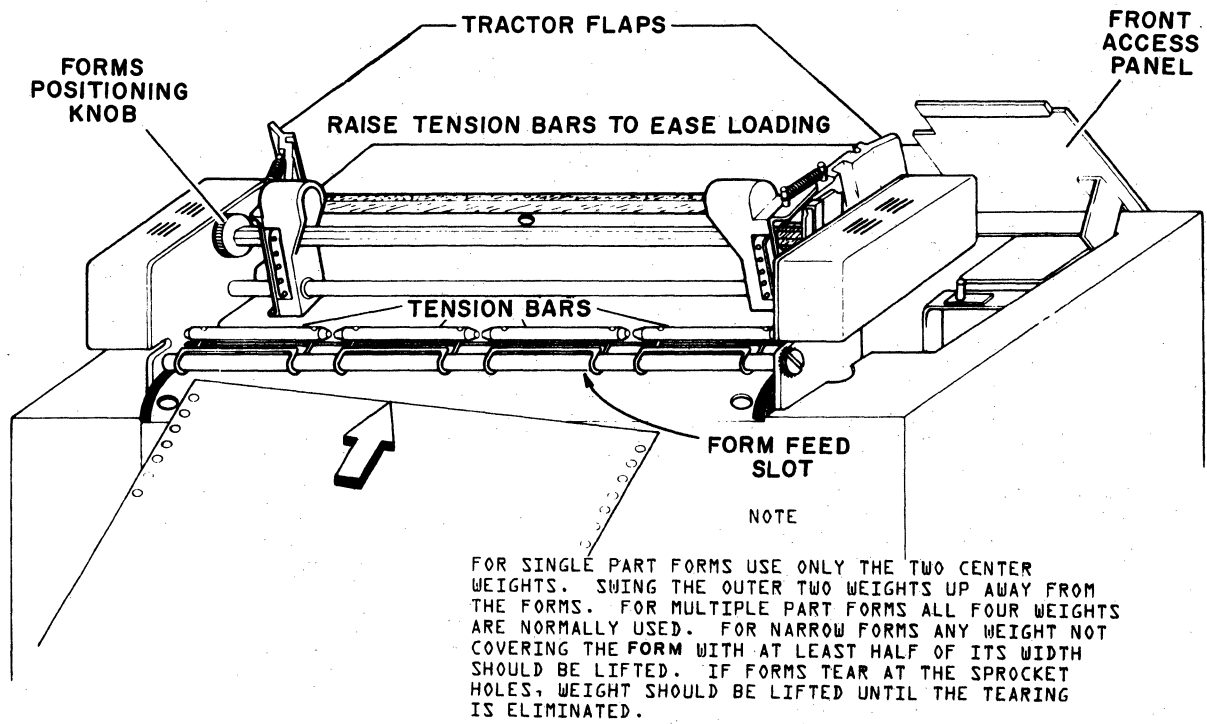

Figure IMP1. Forms Installing/Aligning in Impact Printer

Procedure IMP4 — Installing Ribbon in Impact Printer

This procedure describes the various operations required for installing ribbon in the impact printer. Use ribbon and ribbon materials as specified under the heading Impact Printer Ribbon Materials at the end of this procedure.

If the new replacement ribbon for the printer comes supplied on a single spool, unload old ribbon from one old spool for reuse as follows:

- 1) Press power ON/OFF switch to OFF and open front access panel.
- 2) Remove ribbon (on spools) from ribbon path in printer (figure IMP2).
- 3) Place spool with most ribbon on right ribbon mandrel (figure IMP2).
- 4) Place other spool on stationary rewind mandrel located just behind right ribbon mandrel.
- 5) Turn printer on.
- 6) When ribbon stops turning, remove both spools, pull ribbon leader from empty spool, and use empty spool for spool loading procedure which follows.

If the new replacement ribbon for the printer comes supplied on a single spool, load it on an empty spool (unload/emptied per preceding steps) for the required second spool as follows:

- 1) Route ribbon from full spool onto empty spool as shown in figure IMP3. Wrap ribbon leader over one of arrow-shaped holding clamps on empty spool hub and pull ribbon back into point of arrow of clamp until solidly hooked. Do not pull so hard that clamp at hub bends up. A minimum of 6 inches (15 cm) of ribbon must exist between point of attachment and reversing eyelet which is imbedded in ribbon end. This is to allow actuating reversing lever next to right mandrel when ribbon is fully unwound from right spool.
- 2) Wind several turns (5 to 6) of ribbon onto empty spool. Ribbon is ready for loading in printer.

To load a ribbon, which is already properly on two spools, refer to figure IMP2 and perform the following:

- 1) Place full spool on left ribbon mandrel.
- 2) Route ribbon around guide rollers making sure it passes through slot in ribbon-reversing sense lever.

- 3) Route ribbon between ribbon guide and printhead and around front guide roller on printhead.
- 4) Route ribbon behind rear guide roller on printhead and then all the way right to behind far guide roller.
- 5) Route ribbon in front of next guide, through slot in ribbon-reversing sense lever, and behind last guide roller.
- 6) Place empty spool on right ribbon mandrel.
- 7) Slide printhead all the way to right and allow it to spring back. This should route ribbon beneath tip of clamp on printhead and ribbon should now be ready for printing.

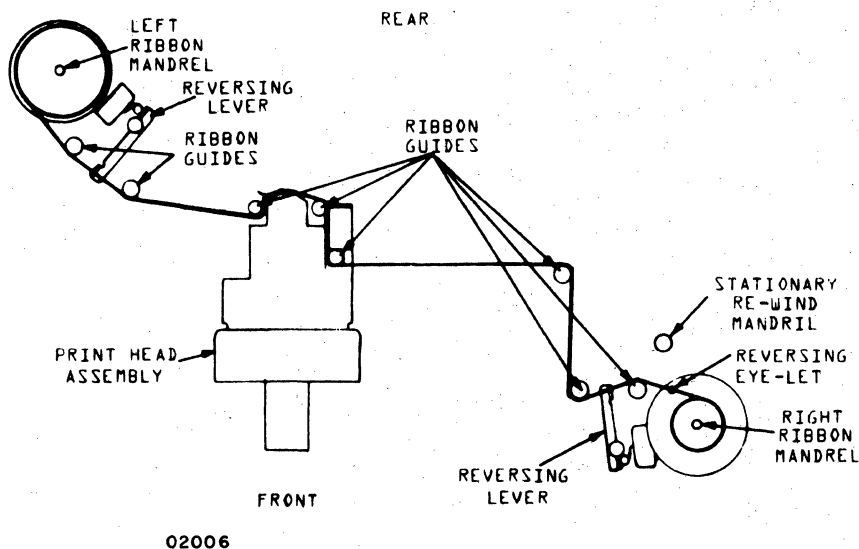

02006

Figure IMP2. Ribbon Path in Impact Printer

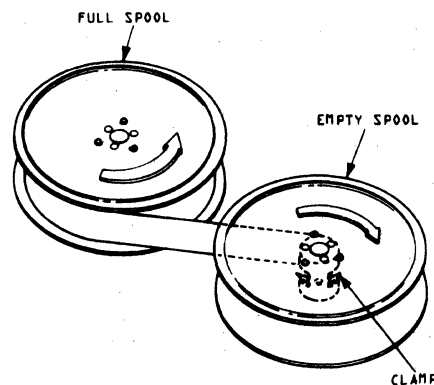

02006

Figure IMP3. Ribbon Positioning on Spools

Impact Printer Ribbon Materials

The ribbon used in this printer is 0.5 inch (1.3 cm) wide by 66 feet (20m) long and runs on an angle across the printing area in order to print on the full width of the ribbon. The ribbon must have an eyelet located at least 6 inches (15.2 cm) from each end for automatic ribbon reversal. Nylon or silk ribbons only must be used. A single spool ribbon must be attached to an empty spool before installation in the printer. The following are recommended ribbon materials:

<u>Item</u>	<u>CDC Part Number</u>
Ribbon and Spools	95371700
Empty Ribbon Spool	76616500
Cleaning Solvent	Any standard commercial type, i.e., Brief, Formula 409, etc.

Procedure IMP5 — Installing Format Tape in Impact Printer

This procedure describes installing the required format tape in the impact printer. Without a format tape in place, printer use will result in a forms runaway condition (no control over forms advance). Use format tape and material as specified under the heading Impact Printer Format Tape Materials at the end of this procedure.

- 1) Press power ON/OFF switch to OFF.
- 2) Remove format reader housing by pulling it, bottom first, away from printer from left side.
- 3) Lift Brush Block Tension Lever.
- 4) Thread format tape loop between Brush Block and Drive Sprocket making sure that channel 1 is at the inside (see figure IMP4 and IMP5). Be certain that tape holes fit neatly over Drive Sprocket pins.
- 5) Route the remaining loop of format tape using either path A or path B as shown in figure IMP4 depending on tape length. Use path B when tension arm cannot take up all slack with tape in path A, or if tension arm is so extended as to touch housing when tape is in path A.
- 6) Lower Brush Block Tension Lever.
- 7) Replace format reader housing by pressing it, top first, over framework of format reader from left side. Format tape should be ready for operation.

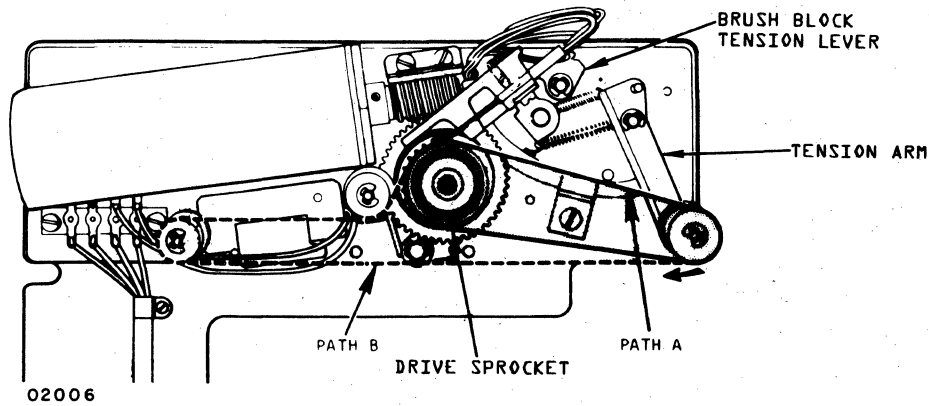

Figure IMP4. Format Tape Path in Impact Printer

Impact Printer Format Tape Materials

The format tape used in this impact printer is a standard 1 inch (2.54 cm) wide tape with sprocket holes on 0.1 inch (0.254 cm) centers (figure IMP5). The standard format tape (76621000) comes with channel 3 (line feed) already punched. Channel 1 should be punched to correspond to the top of forms positions. Channel 2 may be punched at any vertical tab desired. The format tape may be any length from 5.5 to 12.5 inches (13.97 to 31.75 cm).

The person servicing the customer site is not normally required to supply format tapes to the customer. If a person wishes, properly punched spare format tapes may be brought to the site for test purposes. If, however, tape must be punched at the site, a special Format Tape Punch (CDC P/N 76657900) must be used along with adhesive Format Tape Splice (CDC P/N 76628200). These items and their proper use is fully described in the companion field service manual for the impact printer (see preface). The customer may purchase and have on-site whatever format tape and punching/splicing equipment/materials are necessary.

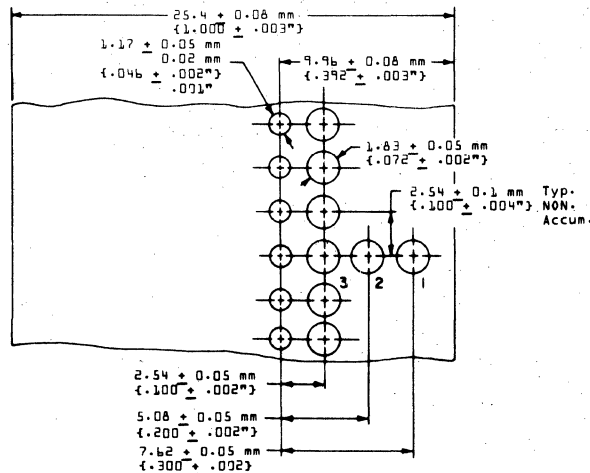

Figure IMP5. Format Tape Characteristics

Procedure IMP6 — Opening/Removing Impact Printer Cabinet

To gain access to interior parts/assemblies of the impact printer, open/remove the cabinet as described by the following procedures.

Open/remove the front access panel (to gain access to entire ribbon path and line start circuit board) as follows:

- 1) Raise front edge of access panel slightly up, carefully slide it toward front of printer until the two retaining tangs (one at the far back on each end of access panel) are fully forward in their slots in upper cabinet, and gently lower access panel until it hangs at front of printer cabinet.
- 2) Remove panel from cabinet (if desired, e.g., in preparation for removing entire cabinet) by lifting panel up again, swinging left side toward back as far as comfortable without jamming it, moving right side of panel toward front and lifting it so right tang lifts out from under cabinet top, and moving entire panel toward the right and front so it lifts off cabinet.

Open the rear, logic chassis panel (to gain access to back interior of cabinet including logic chassis, I/O connector, driver board, tractor assembly locks/connector, etc.) as follows:

- 1) Loosen the four twist-lock fasteners — located along top and side of backpanel which covers entire back of printer cabinet — by a quarter turn counterclockwise each.
- 2) Carefully tilt top of panel back and lower it so it hangs on its retaining chain.

WARNING

Interior of cabinet has hazardous voltage.
Exercise extreme caution if power is left on or
turn power off and disconnect ac power cord from
site outlet.

Remove the entire upper cabinet (to gain access to front interior of cabinet including drive motor, clutch, drive belt, character start assembly, code disc and pulley assembly, etc.) as follows:

- 1) Open rear, logic chassis panel by preceding two steps.
- 2) Disconnect tractor assembly cable at its connector on logic chassis backplane board (figure IMP10).

- 3) Release tractor assembly by reaching into upper left and right corners of rear panel opening, pressing the two tractor assembly locks, and lifting tractor assembly off. Set tractor assembly aside in a safe place.
- 4) Grasp upper cabinet firmly on each side and lift straight up to release it from its spring-loaded fasteners. Carefully continue raising cabinet until it clears interior parts and set it aside in a safe place.

Replace any/all of the items removed in this procedure by reversing the steps which removed them.

Procedure IMP7 — Removing/Replacing Logic Chassis Circuit Boards

To remove circuit boards from the logic chassis, perform the following:

- 1) Press power ON/OFF switch to OFF.
- 2) Open rear logic chassis panel (procedure IMP6).
- 3) Release friction clamp arms holding board (figure IMP6) in place.
- 4) Withdraw board from card cage.

To replace circuit boards in the logic chassis, perform the following:

- 5) Press power ON/OFF switch to OFF.
- 6) If board contains switches and/or jumpers, check their settings/placements (figure IMP7) per terminal subsystem requirements.
- 7) Place board in correct location (figure IMP6) and carefully slide board in track until board touches connector sockets at back.
- 8) Carefully draw board into connector sockets by evenly and firmly locking both friction clamps.

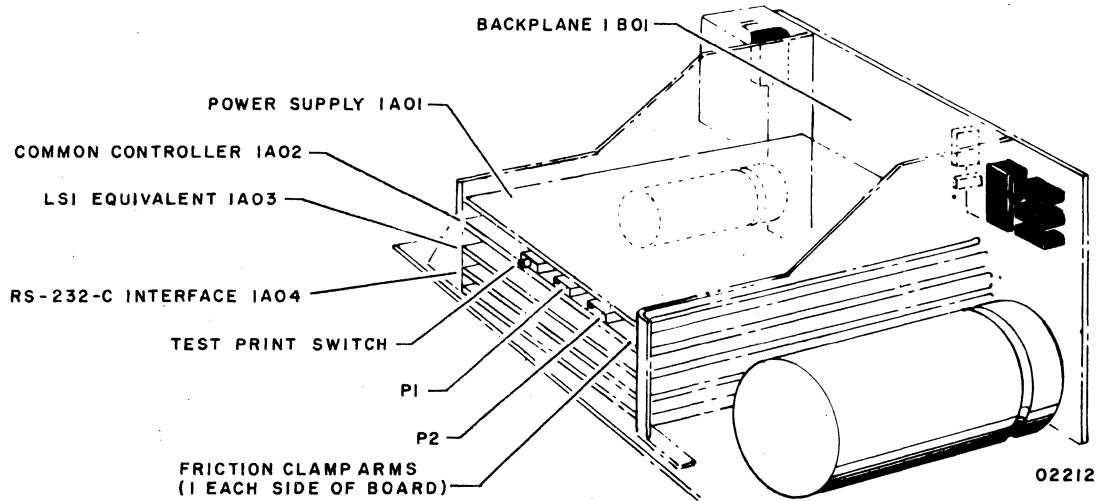

Figure IMP6. Logic Chassis Board Locations

Procedure IMP8 — Checking/Setting Internal Switches and Jumpers

To check/set internal switches and jumpers for the impact printer, proceed as follows:

- 1) Open rear logic chassis panel (procedure IMP6).
- 2) Remove RS-232-C interface board 1A04 (procedure IMP7).
- 3) Verify that all switches and jumpers (figure IMP7) conform to the interface configuration required for correct operation with the keyboard display logic (refer to printer interface control switches shown in figure CRT55).
- 4) Replace RS-232-C interface board back in slot 1A04 (procedure IMP7).

Procedure IMP9 — Removing/Replacing Driver Circuit Board

To remove the driver circuit board 2A01 (figure IMP15), perform the following:

- 1) Press power ON/OFF switch to OFF.
- 2) Open rear logic chassis panel (procedure IMP6).

NOTE

Before replacing a suspected faulty driver board, inspect the four solenoid fuses on the board (procedure IMP12). If replacing a faulty fuse solves the problem, do not proceed with replacing the driver board.

- 3) Reach in through rear panel accessway and remove the two screws from printhead ribbon-cable retainer at lower center of driver board.
- 4) Carefully pull each of the four connectors from driver board (these are 2J01, 2J02, 2J03, and 2J04 as shown on figure IMP8) being careful to note/mark which is top/bottom of each connector so proper reconnection is possible.
- 5) Using a short stubby screwdriver, remove all four screws located along bottom of driver board and lift driver board out of cabinet through rear panel accessway.

To replace the hammer driver circuit board, perform the preceding removal steps in reverse order.

Procedure IMP10 — Removing/Replacing Line Start Circuit Board

To remove the line start circuit board 3A01 (figure IMP15), perform the following:

- 1) Press power ON/OFF switch to OFF.
- 2) Open front access panel (procedure IMP6).

- 3) Slide printhead halfway toward right and block it there with some nonmetallic object which will lay between printhead and left chassis endplate, e.g., a thin, hardcover book may be placed, binding down, between printhead guide rods and between printhead and left endplate.
- 4) Reach down under left end of printhead guide rods and disconnect connector (3J02) from line start board (figure IMP10).
- 5) Using a short stubby screwdriver, remove both screws located diagonally in middle of line start board and lift board out.

To replace the line start circuit board, perform the preceding removal steps in reverse order.

Procedure IMP11 — Removing/Replacing Character Start Circuit Board

To remove the character start circuit board 3A02 (figure IMP15), perform the following:

- 1) Press power ON/OFF switch to OFF.
- 2) Remove entire upper cabinet (procedure IMP6).
- 3) Disconnect connector (3J04) from character start board (figure IMP10).
- 4) Remove both screws located diagonally in middle of character start board and carefully remove board away from code disc assembly.

To replace the character start board, perform the preceding removal steps in reverse order.

Procedure IMP12 — Check/Replace Fuses

Fuses are located in three different functional areas within the impact printer. These locations are: the hammer driver board 2A01, the power supply board 1A01 in the logic chassis, and (for 50-Hz units only) in each of the four secondary outputs from the power transformer 2T01.

Check/replace hammer driver board fuse(s) as follows:

- 1) Press power ON/OFF switch to OFF.
- 2) Open rear logic chassis panel (procedure IMP6).
- 3) Carefully observe suspect fuse (figure IMP8) and replace with a new fuse if burned out.

Check/replace power supply board fuse(s) as follows:

- 1) Press power ON/OFF to OFF.
- 2) Open rear logic chassis panel (procedure IMP6).
- 3) Observe fuses (figure IMP9). Replace if burned out.

Check/replace each fuse in the secondary of 2T01 (figure IMP15) in a 50-Hz unit as follows:

- 1) Press power ON/OFF to OFF.
- 2) Remove entire upper cabinet (procedure IMP6).
- 3) Observe fuses (figure IMP10). Replace if burned out. Identification for these power transformer fuses is as follows:

Top fuse (2F01): 10 amp (+28-V dc)
Second fuse down (2F02): 6.25 amp (+13-V dc)
Third fuse down (2F03): 1 amp (+16-V dc)
Bottom fuse (2F04): 1 amp (+24-V dc)

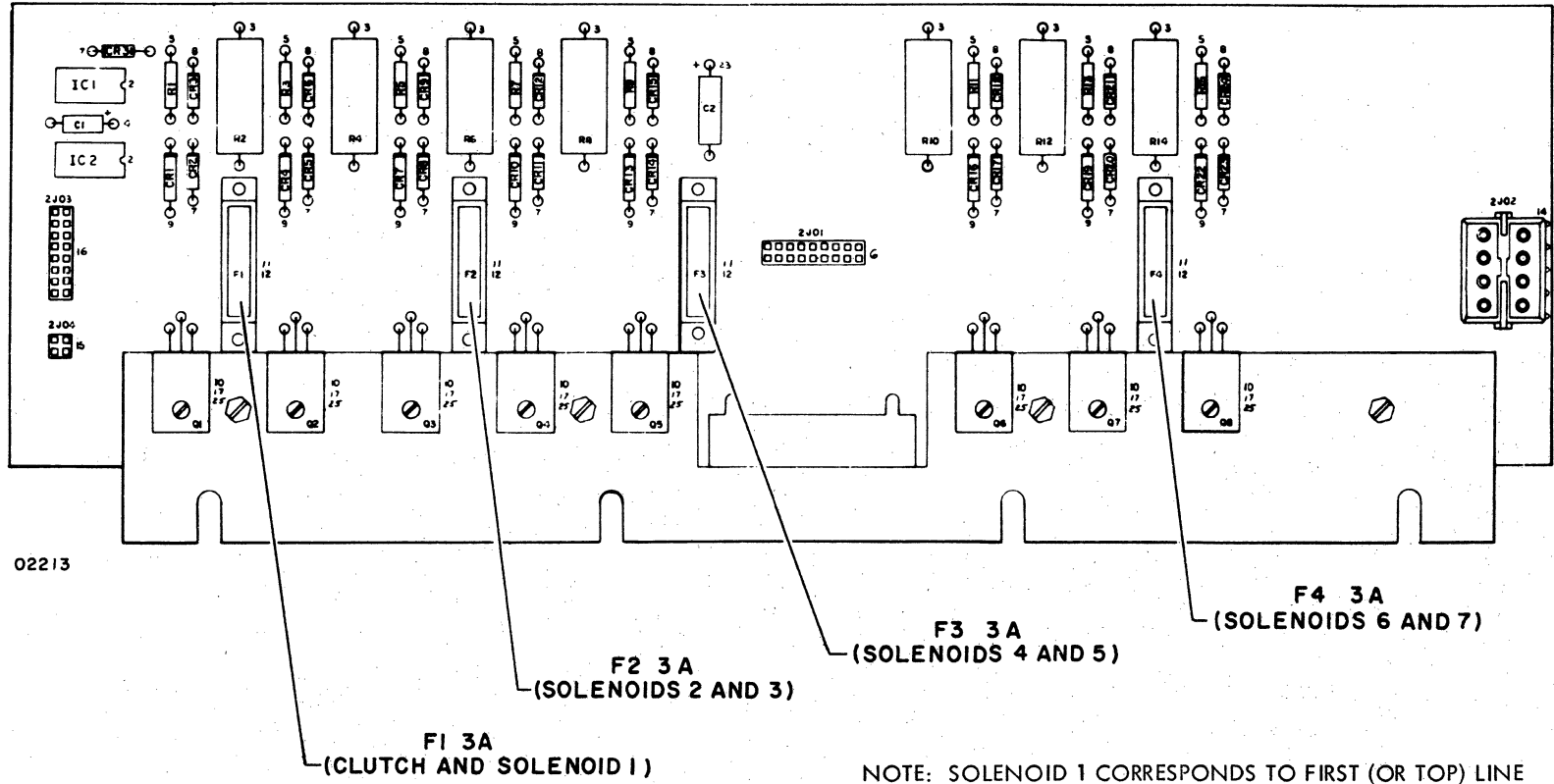

Figure IMP8. Solenoid Driver Board with Fuse Identification

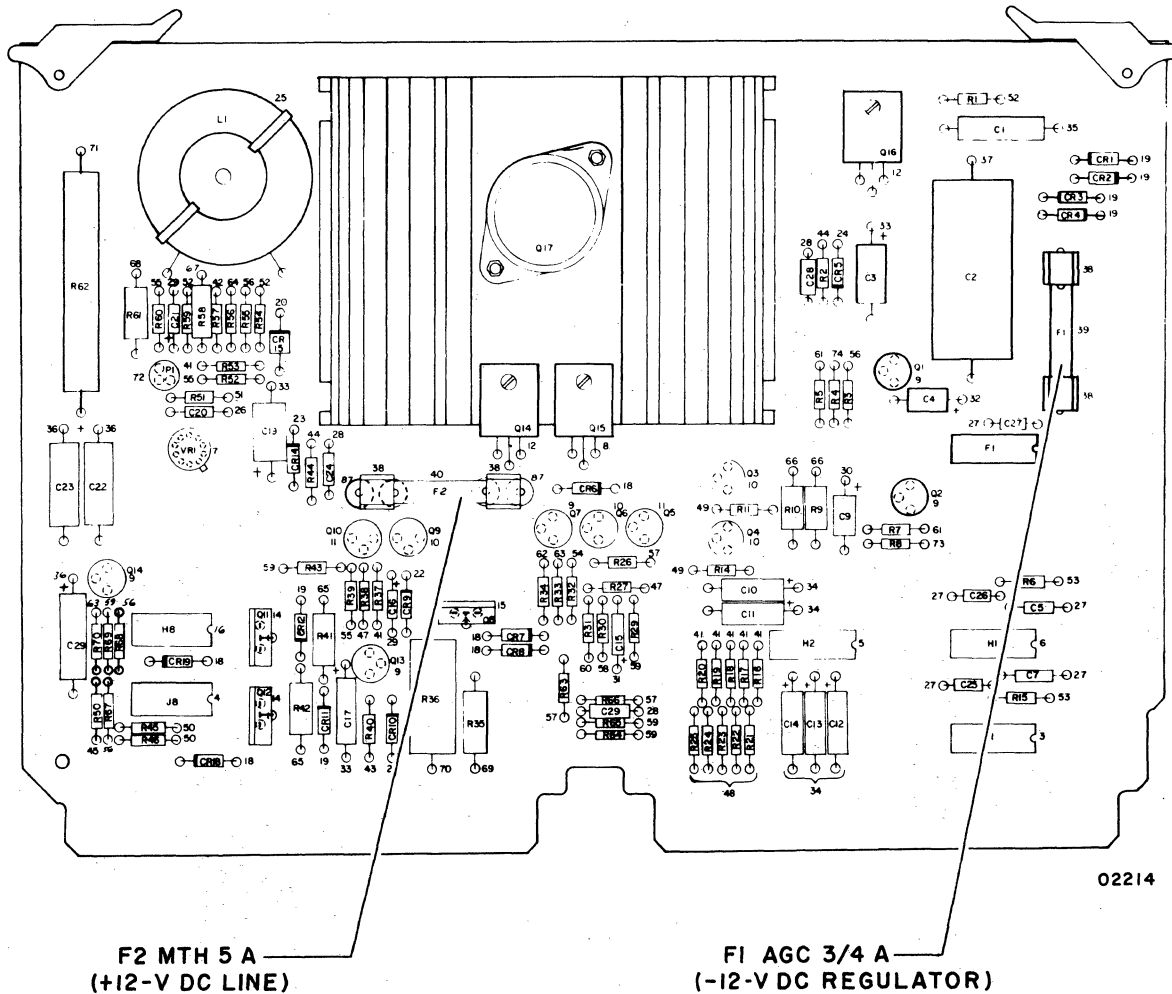
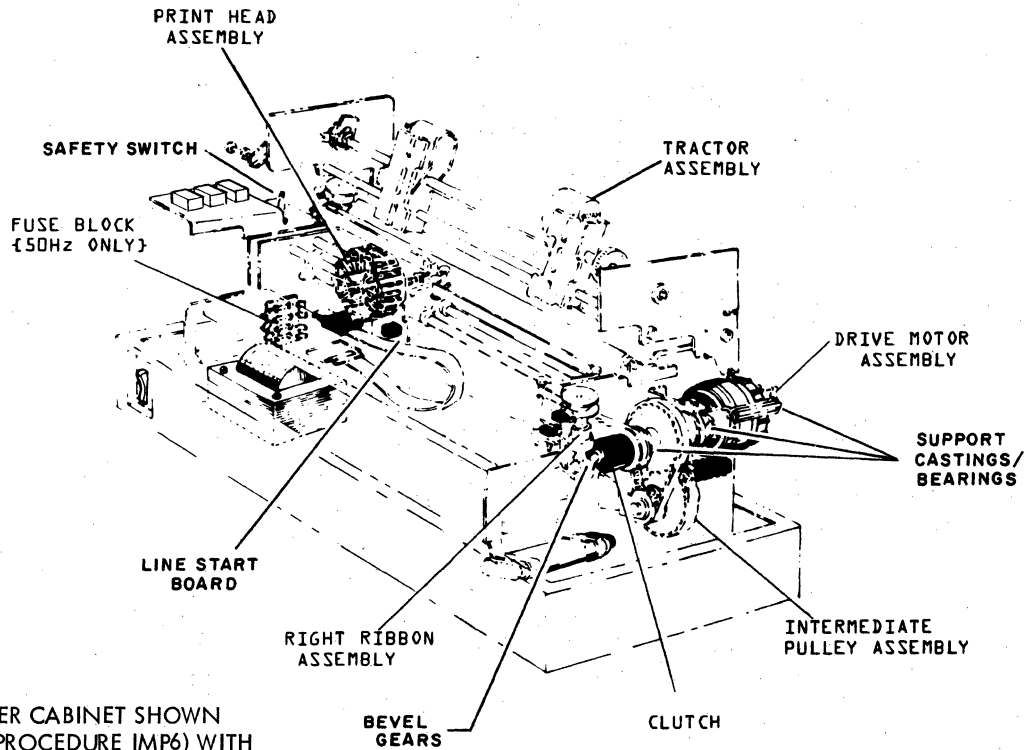
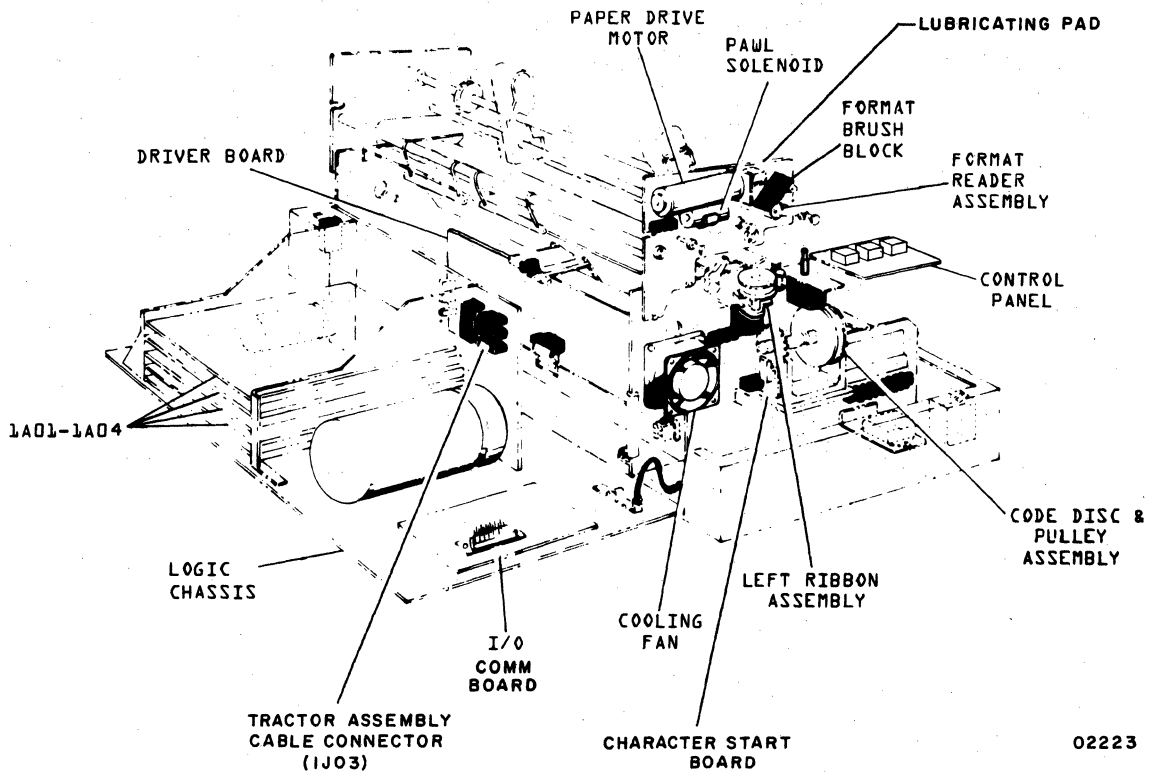

Figure IMP9. Power Supply Board with Fuse Identification



NOTE: UPPER CABINET SHOWN REMOVED (PROCEDURE IMP6) WITH TRACTOR ASSEMBLY REINSTALLED



02223

Figure IMP10. Impact Printer Major Assemblies

Procedure IMP13 — Removing/Replacing Internal Cables

To remove any cable within the printer, on either or both ends, proceed as follows:

- 1) Press power ON/OFF switch to OFF.
- 2) Refer to internal cable/connector diagrams (figures IMP11, 12, 13, and 14) for cable general location/routing. See figures IMP11 and IMP16 for chassis connector locations.

WARNING

For any cable/wiring on the primary side of the power transformer (2T01), the input power cord must be disconnected from the site power outlet. Also, whenever working near any portion of input power, whether input lines or various terminal blocks/pins, the power cord must be disconnected. It is good practice to always disconnect the input power cord when doing any remove/replace work inside the printer. The exception to this may be removing the slide-out logic chassis circuit cards or other similarly simple procedures which may require only the ON/OFF switch set to OFF. If in doubt, always disconnect the input power cord from the site outlet.

- 3) Open cabinet as required to gain access to cable (procedure IMP6).
- 4) While carefully noting pin orientation/location to enable proper reconnection (mark/tag if required), carefully disconnect desired cable.
- 5) Remove any/all cable ties which may hold cable in place. Make it a point to remember where such ties were placed for proper retying later.
- 6) Carefully work entire length of cable (and attached connectors) free from its route and out of printer.

Replace any cable within the printer as follows:

- 7) Verify having correct cable (see impact printer parts manual identified in preface of this manual).
- 8) Carefully work cable (and attached connectors) into its proper place (see impact printer parts manual and field service manual, both identified in preface of this manual).

- 9) Secure as required with cable ties.
- 10) Carefully reconnect connections properly.
- 11) Close cabinet and/or apply power (procedure IMP1) as desired.

Procedure IMP14 — Checking Internal Cables

- 1) Open cabinet as required (procedure IMP6) to access cable.
- 2) Visually inspect connections. If loose or open, secure, and if using this procedure from a DDLT, return to the DDLT and check results before proceeding with following steps of this procedure.
- 3) Disconnect cable connections from both ends of suspected wire(s) (procedure IMP13, steps 1 through 4).
- 4) Carefully inspect connector pins on both ends for possible damage. If damaged pin(s) found, replace pin(s), connector in which pin(s) reside, or entire cable (procedure IMP13, steps 4 through 11) — whichever best meets existing spares availability and immediate customer needs. Refer to the impact printer parts manual (see preface) for all parts identification).
- 5) Using the interconnection diagrams provided in the impact printer field service manual (see preface), do a pin-to-pin continuity check with an ohmmeter or continuity-checking idiot-light.
- 6) If open wire(s) found, repair if possible/desired (e.g., solder loose connection at connector or replace broken wire in bundle) or replace faulty cable with a new one (procedure IMP13, steps 4 through 11).

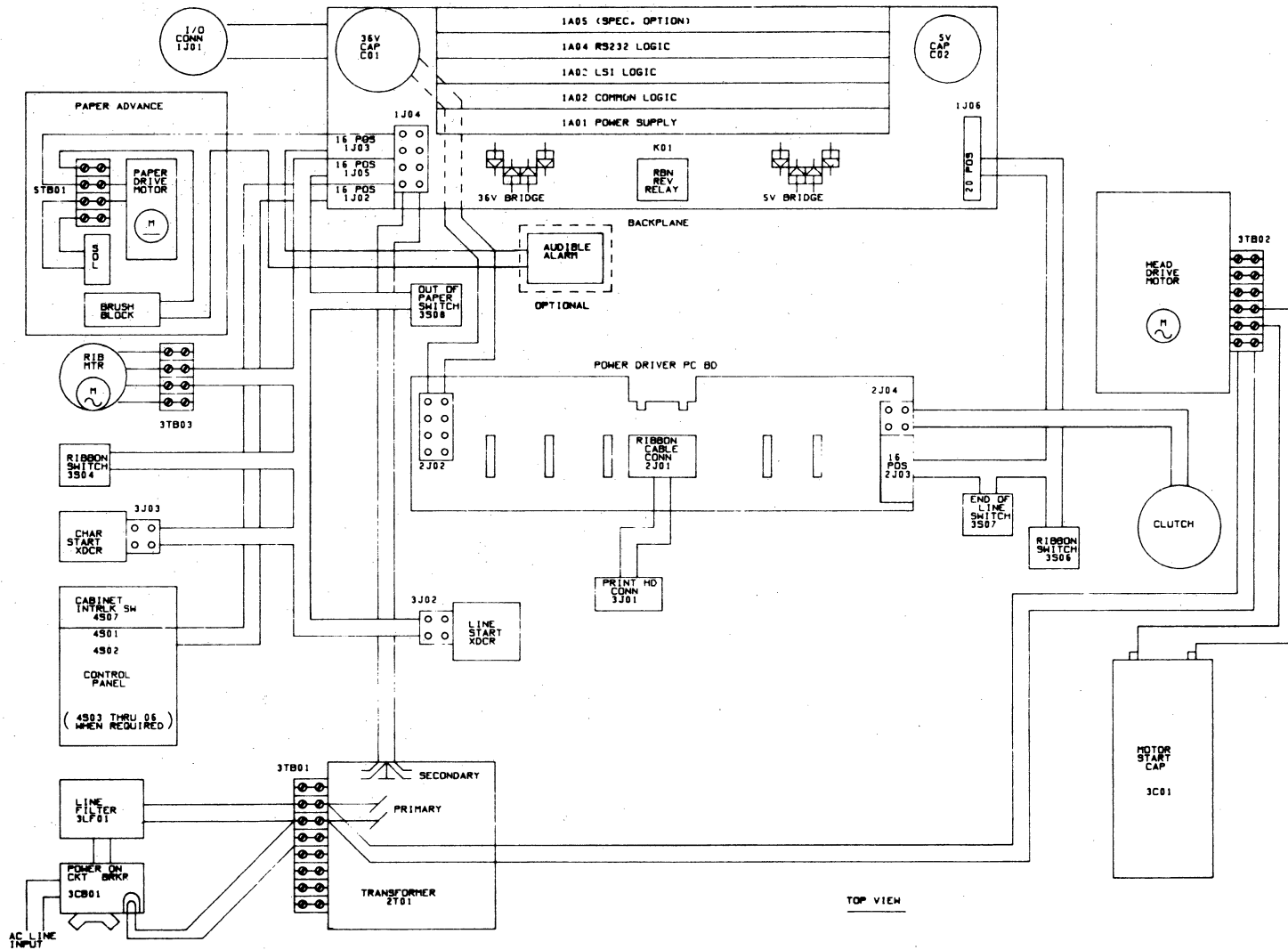
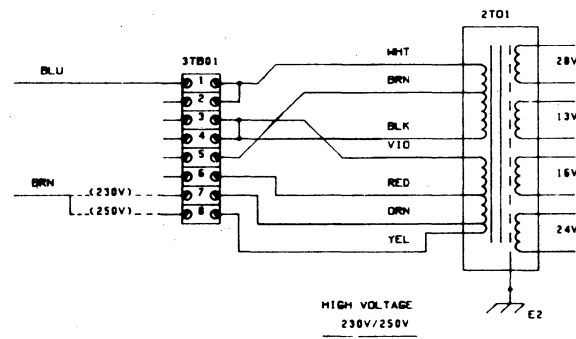
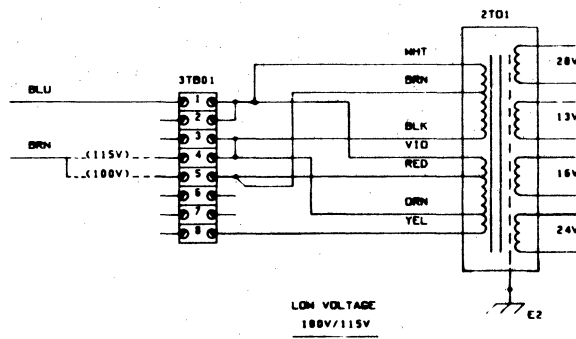
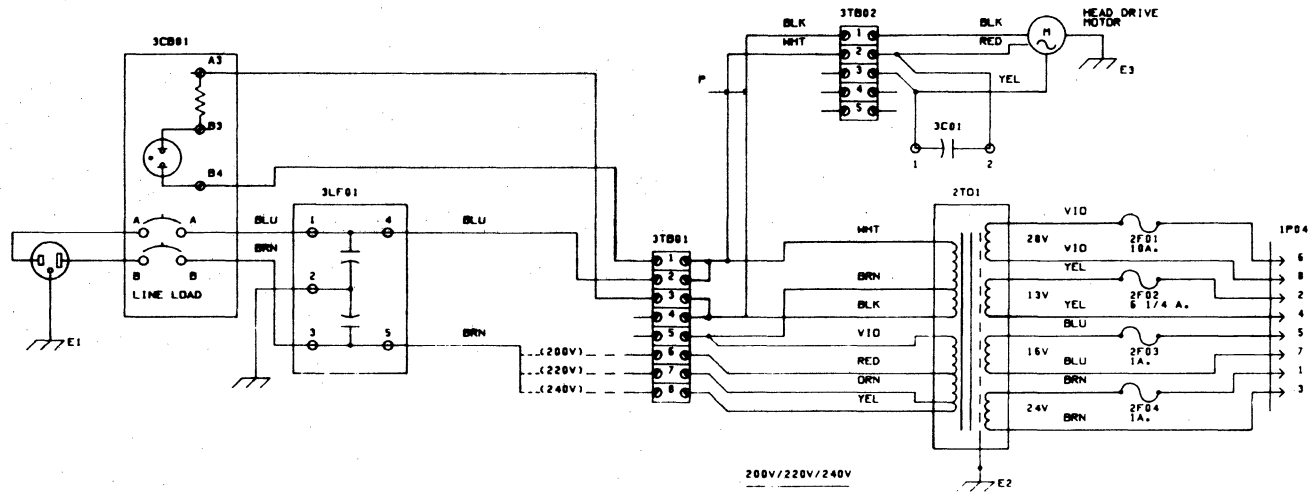

Figure IMP11. Impact Printer Internal Connectors



UNIVERSAL TRANSFORMER

02217

Figure IMP13. Universal AC Distribution

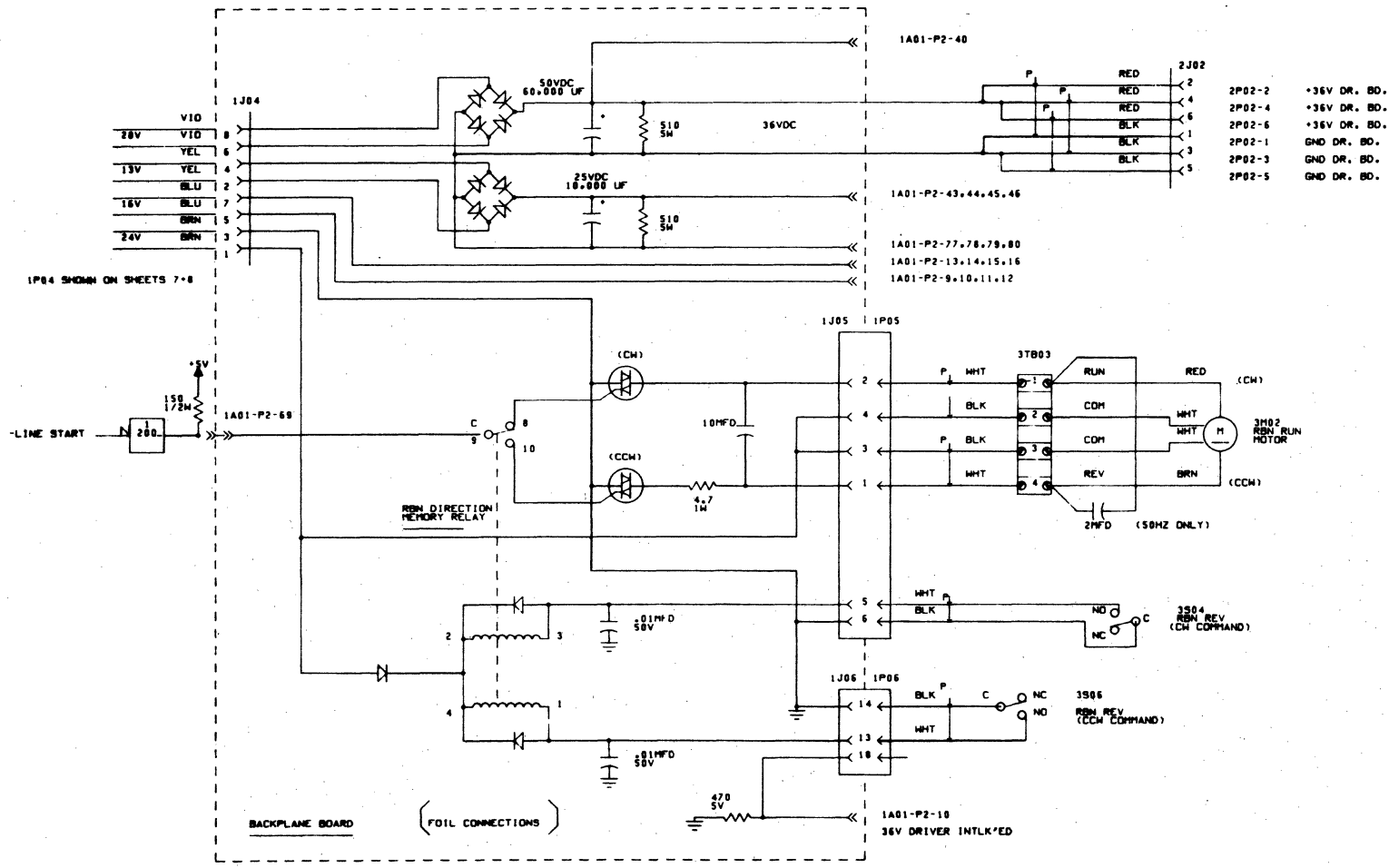

Figure IMP14. DC Distribution and Ribbon Logic

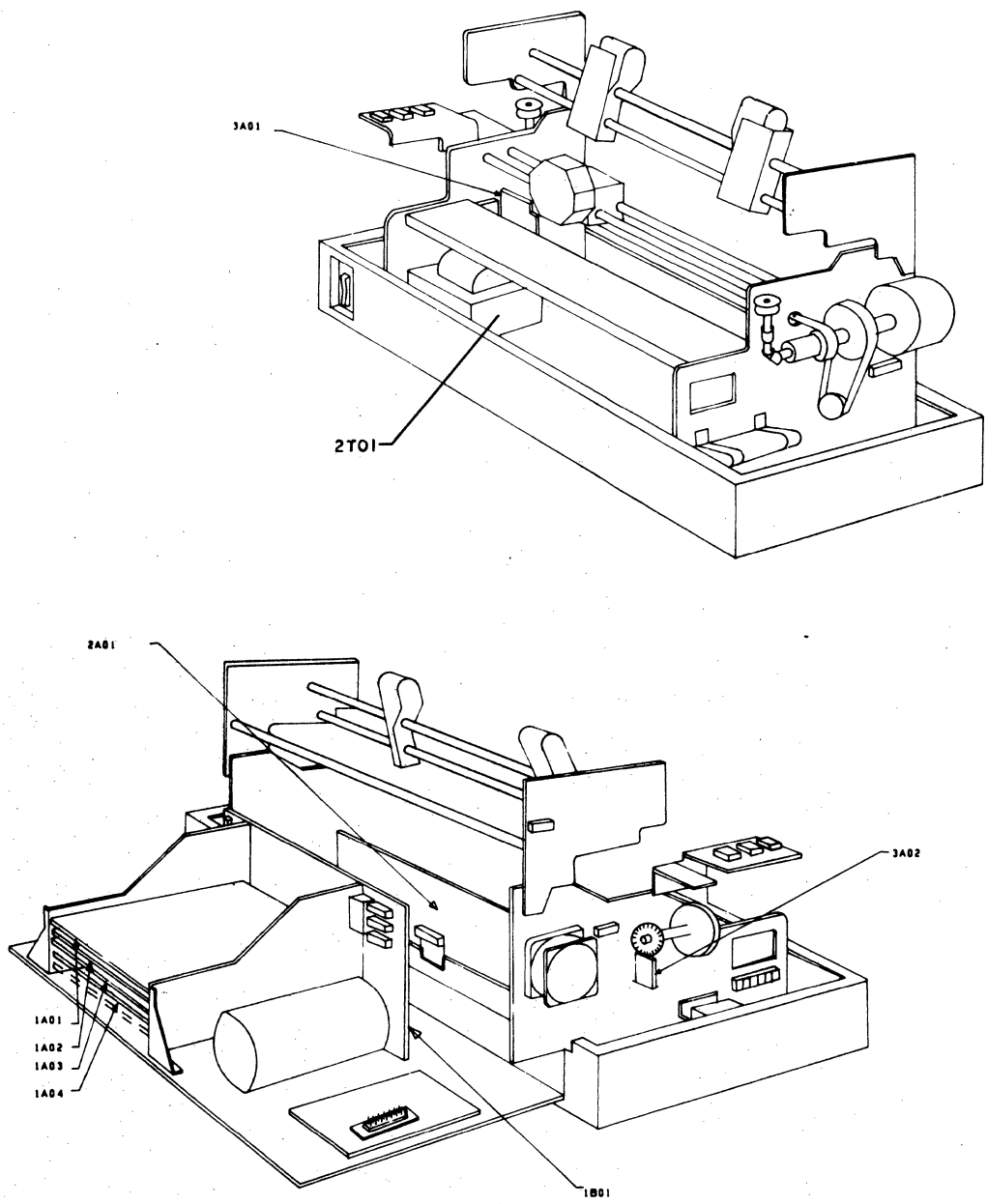
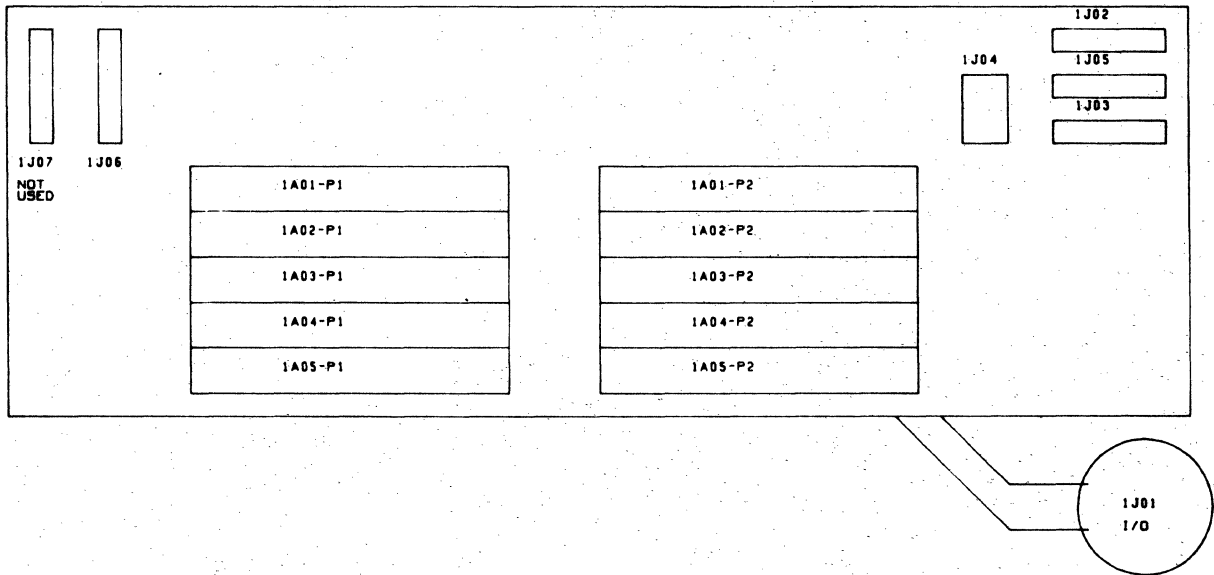

Figure IMP15. Configuration Drawing

POWER SUPPLY 00101, 00102, 00103	1A01 95365400
COMMON CONTROLLER 00201 THRU 00206	1A02 76647800
CONTROLLER - LSI EQUIV 00301 THRU 00304	1A03 76647600
RS232 INTERFACE 00401	1A04 95411000
00501	1A05

BACKPLANE
00601, 00602

1B01
95365600



DRIVER BOARD
00701

2A01
76648000

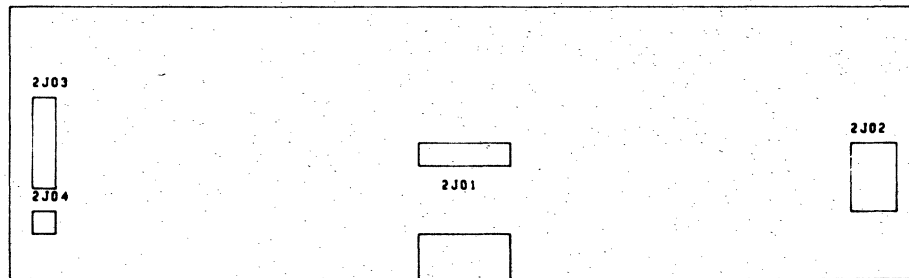

LINE START BOARD
00801

3A01
76648200

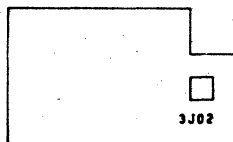

CHARACTER START BOARD
00901

3A02
76642000

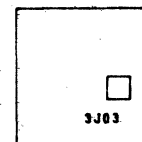

02224

Figure IMP16. Chassis Map

Procedure IMP15 — Mechanical Checks/Adjustments

A variety of detailed mechanical checks and adjustments may be performed on the impact printer at the customer site. The field service manual (see preface) contains the procedures for such tasks in its Maintenance section. The procedures provided there, which meet the maintenance philosophy for the printer as part of the terminal subsystem, are as follows:

- Belt Tension
- Clutch Assembly
- Ribbon Tracking
- Printhead (except printwire ends adjustment)
- Code Disc Assembly
- Paper Motion System
- Format Reader Brush
- Dashpot
- Ribbon Reversing Switch
- Out of Paper Switch
- Clamp Lever (tractor)
- End of Line Switch

When it appears necessary to perform any of these checks/adjustments, do so using the tools and materials specified in the procedures and listed at the beginning of the Maintenance section in the field service manual.

Procedure IMP16 — Electrical Checks/Adjustments

A few electrical checks and adjustments may be performed on the impact printer at the customer site. The field service manual (see preface) contains the procedures for such tasks in its Maintenance section. When it appears necessary to perform any of these checks/adjustments, do so using the tools and materials specified in the procedures (and listed at the beginning of the Maintenance section in the field service manual). The electrical check/adjustment procedures provided there, which meet the maintenance philosophy for the printer as part of a terminal subsystem, are as follows:

- +5-V dc Output Voltage Adjustment
- Line Start and Character Start Synchronization (oscilloscope required)
- Character Firing Time and Width Adjustment (oscilloscope required)

Procedure IMP17 — Parts Replacement

The field service manual (see preface) contains the procedures for replacing many subassembly parts within the impact printer. These are in addition to the remove/replace procedures given preceding in this section. A list of these parts replacement procedures follows. When it appears necessary to perform any of these replacements, do so using the tools and materials specified in the procedures (and listed at the beginning of the Maintenance section in the field service manual). The replacement procedures provided there, which meet the maintenance philosophy for the printer as part of a terminal subsystem, are as follows:

CAUTION

When removing/replacing any assembly/part, always, as a minimum, press power ON/OFF switch to OFF. This prevents mechanism motion and also prevents electrical arcing when disconnecting circuits. If working near or replacing/disconnecting any input power circuits, always disconnect the input power cord from the site power outlet. It is good practice to always disconnect the input power cord whenever working on any of the circuits within the printer.

- Drive Motor
- Intermediate Pulley Assembly
- Clutch Drive Mechanism
- Right Ribbon Mechanism
- Support Shaft Assembly
- Dashpot Assembly
- Printhead Disassembly (removal part only, disassembly not recommended at customer site)
- Code Disc Pulley Assembly
- Left Ribbon Assembly
- Paper Motion System
- Format Reader Brush

- Format Reader Brush Block
- Format Reader Disassembly
- Platen Removal
- Cooling Fan Assembly

To replace items not included either in the preceding list or in the preceding procedures in this section (that is, ON/OFF circuit breaker switch, power transformer, various backplane components, etc.) refer to the impact printer parts manual (see preface) for parts identification and disassembly/assembly drawings. Use the tools and materials specified at the beginning of the Maintenance section in the field service manual (see preface) and proceed to disassemble (remove) and replace the necessary item according to the parts drawings.



TABLE TCUI. DDLT FOR TAPE CASSETTE UNIT (SHEET 1 OF 2)

POWER ON AND CONTROLS CHECKS													
Tape unit I/O cable connected to CASSETTE I/O connector on back of tape unit cabinet and to PERIPHERAL CONNECTOR of checked-out keyboard display terminal (procedure TS1). Power off at keyboard display terminal. Tape unit ac input power cord attached to proper ac power (procedure TCUI).													
CONDITIONS	SITUATIONS												
	1	2	3	4	5	6	7	8	9	10	11	12	13
Apply power to tape cassette unit (procedure TCUI) without placing power on keyboard display terminal. Did fan at back of tape unit cabinet start and green POWER indicator illuminate for each tape drive unit present?	Y	Y	Y	Y	Y	Y	Y	Y	Y	N	N	N	
Is fan running but green POWER indicator(s) not lit?	-	-	-	-	-	-	-	-	-	Y	N	N	
Green POWER indicator(s) lit but fan not running?	-	-	-	-	-	-	-	-	-	-	Y	N	
READ and WRITE amber lights both glowing?	Y	Y	Y	Y	Y	Y	Y	Y	N	-	-	-	O
Load scratch cassette in each drive unit present (single or dual), close covers, and observe control panel lights. POWER light(s) still glowing green and amber READ and WRITE lights still glowing?	Y	Y	Y	Y	Y	Y	Y	N	-	-	-	-	T
While observing tape unit control panel lights, switch keyboard display power on. READ and WRITE amber lights go out?	Y	Y	Y	Y	Y	Y	N	-	-	-	-	-	H
Tape drive(s) begin rewinding to start of tape?	Y	Y	Y	Y	Y	N	-	-	-	-	-	-	E
TAPE OUT red light goes on for each tape drive present when tape rewind stops?	Y	Y	Y	Y	N	-	-	-	-	-	-	-	R
Tape drive(s) advance at slow speed a short way (to BOT) and stop moving tape. At same time, TAPE OUT red light(s) extinguish and green READY indicator illuminates for each tape drive present?	Y	Y	Y	N	-	-	-	-	-	-	-	-	
Press MASTER CLEAR switch on back of keyboard display. Do the preceding three conditions (rewind, stop, and advance to BOT) repeat as when keyboard display power was turned on?	Y	Y	N	-	-	-	-	-	-	-	-	-	
Press UNLOAD switch for each drive present. Does green READY light go out, tape drive rewind to clear leader and stop, and TAPE OUT red light come on?	Y	N	-	-	-	-	-	-	-	-	-	-	
ACTIONS	SEQUENCE												
Perform subsystem operational checks, sheet 2 of this DDLT.	X	-	-	-	-	-	-	-	-	-	-	-	-
Check tape for small BOT hole pierced a few inches past clear leader. If no hole, replace with tape which has.	-	-	-	1	-	-	-	-	-	-	-	-	-
Check internal cables/wires to/from nonfunctioning item(s) (procedure TCUI3).	-	2	1	-	1	1	6	4	1	1	1	2	-
Check power supply output (procedure TCUI6). Adjust/replace as necessary (procedure TCUI7).	-	-	-	-	-	2	-	-	-	2	-	-	-
Replace ac entry panel (procedure TCUI8).	-	-	-	-	-	-	-	-	-	-	-	3	-
Replace fan assembly (procedure TCUI9).	-	-	-	-	-	-	-	-	-	-	2	-	-
Replace LED board (procedure TCUI10).	-	7	6	-	5	-	-	5	5	3	-	-	-
Replace nonfunctioning tape drive (procedure TCUI12).	-	6	7	5	6	6	-	-	-	-	-	-	-
Check/replace front panel switches (procedure TCUI11).	-	5	-	-	-	-	-	-	-	-	-	-	-
Replace I/O and delay logic circuit board 01 (procedure TCUI5).	-	1	3	2	2	4	3	1	2	-	-	-	-
Replace read/write logic circuit board 02 (procedure TCUI5).	-	4	5	4	4	5	5	3	4	-	-	-	-
Replace control logic circuit board 03 (procedure TCUI5).	-	3	4	3	3	3	4	2	3	-	-	-	-
Check ac power outlet for proper power (see specifications in section 1).	-	-	-	-	-	-	-	-	-	-	-	1	-
Check seating of tape cassette interface control board 07 in display logic module. If no improvement, replace (procedure CRT8).	-	-	2	-	-	-	1	-	-	-	-	-	-
Check subsystem I/O cable between keyboard display and tape unit (procedure TS4).	-	-	-	-	-	-	2	-	-	-	-	-	-
Call next level of support.	-	-	-	-	-	-	-	-	-	-	-	-	X
Note: After completing any repairs or maintenance, verify that the subsystem is fully operational by rerunning test mode.													

TABLE TCUI. DDLT FOR TAPE CASSETTE UNIT (SHEET 2 OF 2)

SUBSYSTEM OPERATIONAL CHECKS								
ASSUME								
Power on and controls checks (sheet 1 of this DDLT) just completed OK and tape cassette unit standing ready as left by those checks. Scratch tape(s), with write enable tabs/plugs in place, loaded in tape drive(s).								
CONDITIONS	SITUATIONS							
	1	2	3	4	5	6	7	8
Lift cover of each tape drive present to initiate ready condition (tape rewinds and advances to BOT). Verify TEST/NORMAL switch on display terminal back panel is at NORMAL. Press MASTER CLEAR on same back panel. Use keyboard to compose short message which should exercise tape unit (see appendix C for a recommended full-screen, tape unit test pattern). Send message to each tape drive present (see terminal subsystem operator's guide for instructions on how to compose and send messages to tape). Using tape control keys provided on both the keyboard and tape unit front panel, read messages just recorded back to display screen and visually verify for accuracy. Did all tape unit operations perform correctly?								
Did CHECK TAPE appear in lower right corner of display screen?	Y	N	N	N	N	N	N	O T H E R
Did TAPE ERROR appear in lower right corner of display screen?	-	Y	N	N	N	N	N	
Trouble composing message intended for tape checking?	-	-	-	Y	N	N	N	
Apparent trouble sending composed message to selected tape drive (drive does not advance for recording message)?	-	-	-	-	Y	N	N	
Apparent trouble reading from selected tape drive (drive does not advance for reading message)?	-	-	-	-	-	Y	N	
Any trouble apparently caused by key malfunction on keyboard?	-	-	-	-	-	-	Y	
Any trouble apparently caused by key malfunction on keyboard?	-	-	-	-	-	-	Y	
ACTIONS	SEQUENCE							
Subsystem checkout of tape cassette unit ran OK. Tape unit is ready for use in subsystem. If entering this table from some other DDLT or procedure, return to that previous task. If checking tape unit only, task is done.	X	-	-	-	-	-	-	
Check condition of tape loaded in tape drive being used. Verify presence of write enable tab/plug if writing, whether end of tape (EOT) is reached, whether tape cassette is properly loaded, and that power is still on at tape unit. Replace tape if necessary.	-	1	-	-	1	1	-	-
Attempt again to record on tape in the same area (following instructions given in the subsystem operator's guide for composing and recording messages on tape). If TAPE ERROR still appears, write an erase on that part of tape (again, see operator's guide). Replace tape if necessary.	-	-	1	-	-	-	-	-
Use table CRT1, DDLT for Display Terminal, and troubleshoot keyboard display terminal.	-	9	9	X	9	9	X	-
Check seating of tape cassette interface control board 07 in display logic module. If no improvement, replace (procedure CRT8).	-	4	4	-	4	4	-	-
Check I/O cable connections between display terminal and tape unit.	-	3	3	-	3	3	-	-
Replace I/O and delay logic circuit board 01 (procedure TCU5).	-	5	5	-	5	5	-	-
Replace control logic circuit board 03 (procedure TCU5).	-	6	6	-	6	6	-	-
Replace read/write logic circuit board (procedure TCU5).	-	7	7	-	7	7	-	-
Check tape unit internal cabling (procedure TCU13).	-	8	8	-	8	8	-	-
Replace nonfunctioning tape drive (procedure TCU12).	-	10	11	-	10	10	-	-
Check position of tape unit I/O front panel switches. Check/replace as necessary (procedure TCU11).	-	2	2	-	2	2	-	-
Call next level of support.	-	-	-	-	-	-	-	X
Note: After completing any repairs or maintenance, verify that the subsystem is operational by rerunning test mode.								

Tape Cassette Unit Corrective Maintenance Procedures — General

Following pages identify all of the procedures that are referenced either from table TCU1, DDLT for Tape Cassette Unit, or from elsewhere within this manual. In addition, other useful procedures are defined.

Keep in mind that whenever a procedure goes to a lower level of replacement than the standard on-site spare parts list (provided in section 8), then it is at the discretion of the customer engineer to simply replace the problem area at the next higher level spare part/assembly which is available and expedient.

WARNING

When working on the ac entry panel or fan, always switch power off and disconnect ac power cord from site power outlet.

Procedure TCU1 — Turning On Tape Cassette Unit Power

To turn power on the tape cassette unit (either single or dual drive), perform the following:

- 1) Verify I/O cable connected between tape unit CASSETTE I/O connector and keyboard display terminal PERIPHERAL CONNECTOR.
- 2) Verify tape unit ac power cord (figure TCU1) connected to proper power from site outlet (see specifications, section 1 for power requirements). For 50-Hz units only: verify INPUT VOLTAGE RANGE SWITCH set at LOW LINE or NORMAL to match range of site power.
- 3) Toggle circuit breaker switch (CB1) up (fan should start and green POWER LED(s) (figure TCU1) should be lit for each drive unit present).

CAUTION

Do not hold/force circuit breaker switch to remain up. Holding it up when it tries to trip will cause serious damage to circuits.

- 4) To make tape unit useable; verify power turned on at keyboard display terminal (procedure CRT1), verify desired tape cassette loaded in drive(s) (procedure TCU3) and covers closed, RECORD/STBY/PLAY switch for the drive(s) set at desired function, and ONLINE/LOCAL switch for the drive(s) pressed toward ONLINE to place cassette unit online with the subsystem. If offline condition desired, for testing etc., leave this switch in LOCAL position. Also, for drive not desired to either record (write) on or play (read) from, set at STBY condition.

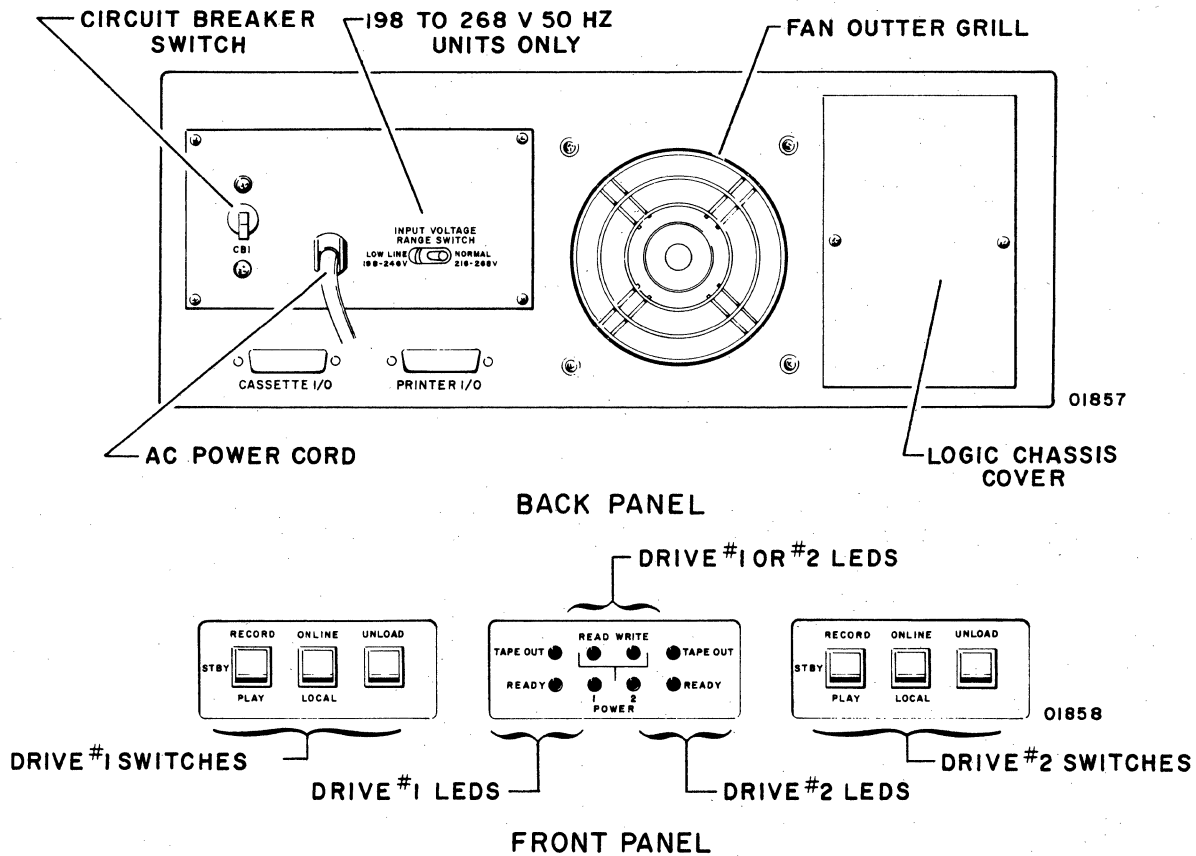

Figure TCU1. Back and Front Panels

Procedure TCU2 — Turning Off Tape Cassette Unit Power

To turn off tape cassette unit power, perform the following:

- 1) Press circuit breaker switch (CB1) on back panel down — green POWER LED(s) should extinguish and fan should slow to stop.
- 2) If desired to remove all power applied to cassette unit cabinet (such as for removing power supply or just to be doubly safe when working inside cabinet), disconnect ac power cord from site outlet.

Procedure TCU3 — Tape Cassette Loading/Unloading

To load a tape cassette in the tape cassette unit, use the following procedure. Use tape cassette and tape cassette materials as specified under the heading Tape Cassette Materials at the end of this procedure.

- 1) Turn power on (procedure TCU2).
- 2) Select desired tape cassette and verify that write enable tab or plug (see Cassette Tape Materials) is present for each side on which writing will be desired (figure TCU1).
- 3) Lift cover over tape drive (do not force cover back beyond the vertical), hold cassette by its side edges with side desired to record/read on/from facing up, slide cassette back edge first into cassette chamber in tape drive with front edge facing you (figure TCU2), and press cassette back/down in chamber until it seats firmly over alignment posts and reel drive hubs.
- 4) Lower cover over tape drive. Unit should automatically rewind (high speed) to beginning of tape and advance (slow speed) to tape start point (a few inches into tape past beginning of tape hole). Green READY indicator for the drive just loaded should light.

To unload a tape cassette, proceed as follows:

- 5) Press UNLOAD switch to rewind tape to clear leader. When TAPE OUT light comes on, tape is at clear leader.
- 6) Lift cover over tape drive (do not force cover back beyond the vertical), press tape ejector button firmly down to pop cassette up, and lift cassette out.

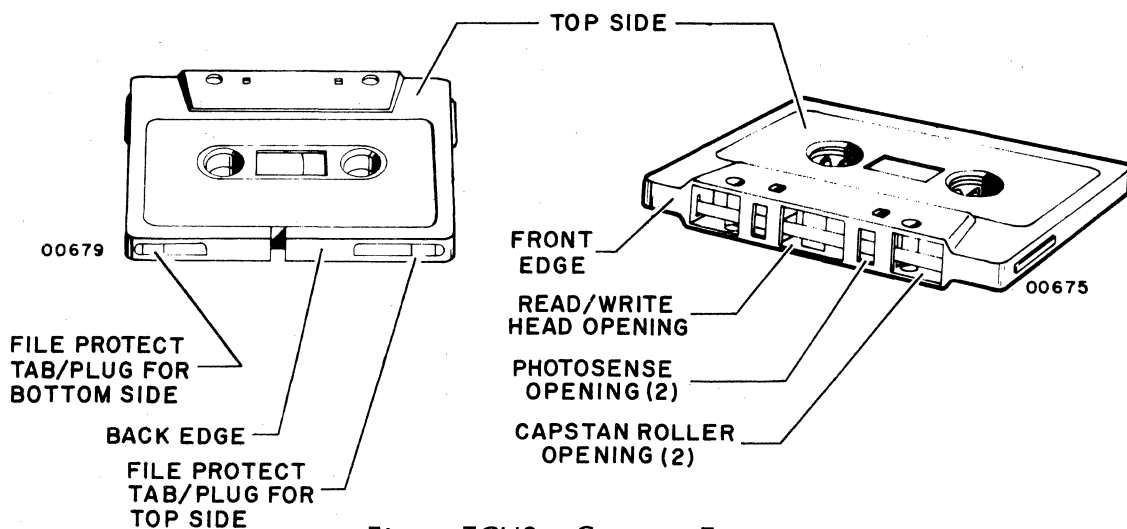

Figure TCU2. Cassette Features

Tape Cassette Materials

The tape cassette unit uses standard computer grade Philips-type cassettes which are compatible with the proposed ANSI X3B5175-55 standard (this standard specifies that the tape must contain EOT and BOT marker holes). Such cassettes have a break-off tab in a hole at the back edge for protecting recorded data on a side from being written over. To allow recording again after the tab is removed requires inserting a standard cassette write-enable plug in the hole. Cassettes must be stored in standard carrying cases when not in use. Required cleaning materials include special cleaning solution designated as magnetic tape head cleaner and standard cotton swabs (as may be purchased at a drug store). All of these tape cassette materials (with the exception of the cotton swabs) are purchased from a supplier of tape cassette materials.

Procedure TCU4 — Opening/Removing Tape Cassette Unit Cabinet

To gain access to interior assemblies/modules of the tape cassette unit, open/remove the cabinet as described by the following procedures.

Open the rear, logic chassis cover (to gain access to logic circuit cards) as follows:

- 1) Remove the two screws (and washers) which hold cover over rear of logic chassis (figure TCU1) and lay cover aside.

CAUTION

Before removing any logic circuit board(s), press power switch down to OFF.

Remove the cabinet hood (to gain access to interior of cabinet including power supply, drive unit(s), cables, etc.) as follows:

- 1) Remove the four screws along the underside front edge of the hood just below front operator controls panel.
- 2) Remove the four screws along the back top edge of the hood.
- 3) Grasp cabinet hood firmly on each side and raise it straight up off of cabinet base (this may be snug fit and require slight jiggling and pulling). Set hood aside in safe place.

WARNING

Interior of cabinet has hazardous voltage. Exercise extreme caution if power is left on or turn power off and disconnect ac power cord from site outlet.

Replace any/all items removed in this procedure by reversing the steps which removed them.

Procedure TCU5 — Removing/Replacing Logic Chassis Circuit Boards

To remove circuit boards from the logic chassis, perform the following:

- 1) Press circuit breaker switch (CB1) down to turn power off.
- 2) Open rear logic chassis cover (procedure TCU4).
- 3) Release friction clamp arm holding board (figure TCU3) in place.
- 4) Withdraw board from card cage.

To replace circuit boards in the logic chassis, perform the following:

- 5) Press circuit breaker switch (CB1) down to turn power off.
- 6) Place board in correct location (figure TCU3) and carefully slide board in track until board touches connector sockets at back.
- 7) Carefully draw board into connector sockets by evenly and firmly locking friction clamp.

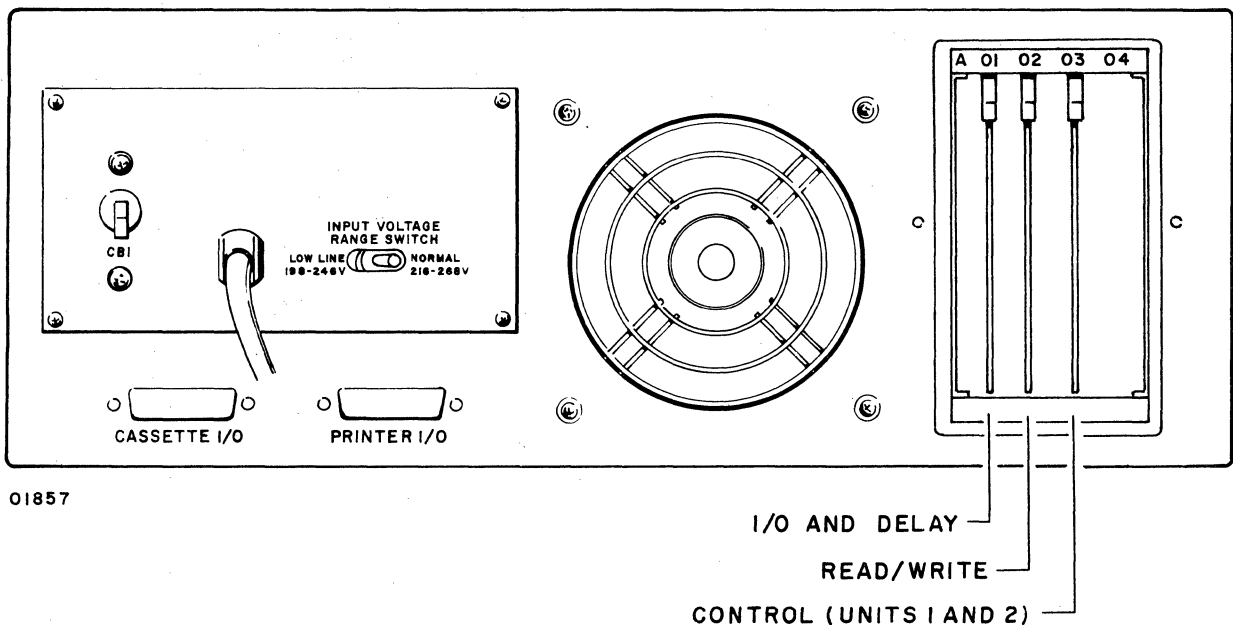

Figure TCU3. Logic Chassis Board Locations

Procedure TCU6 — Checking/Adjusting Power Supply Output

To check/adjust the performance of the power supply module in the tape cassette unit, proceed as follows:

- 1) Remove cabinet hood (procedure TCU4).
- 2) With cassette(s) loaded in drive unit(s) (procedure TCU3), press circuit breaker switch up to turn power on (places a typical operating load on power supply output).

NOTE

A warm-up period of 15 minutes with power supply operating, before checking/adjusting, is recommended for best results.

- 3) Refer to figure TCU4, set meter to appropriate range for good scale deflection, and measure each output voltage at test points shown (use ground test point on each card to measure voltage(s) on that card). For any voltage more than $\pm 5\%$ from its nominal specified in figure TCU4, continue measuring output while adjusting per following step.
- 4) To adjust any output voltage, refer to figure TCU4 and gradually turn identified adjustment screw until voltage is within $\pm 5\%$ and as close as possible to exact nominal voltage.

If power supply output will not adjust to within specified tolerances, replace entire power supply module (procedure TCU7).

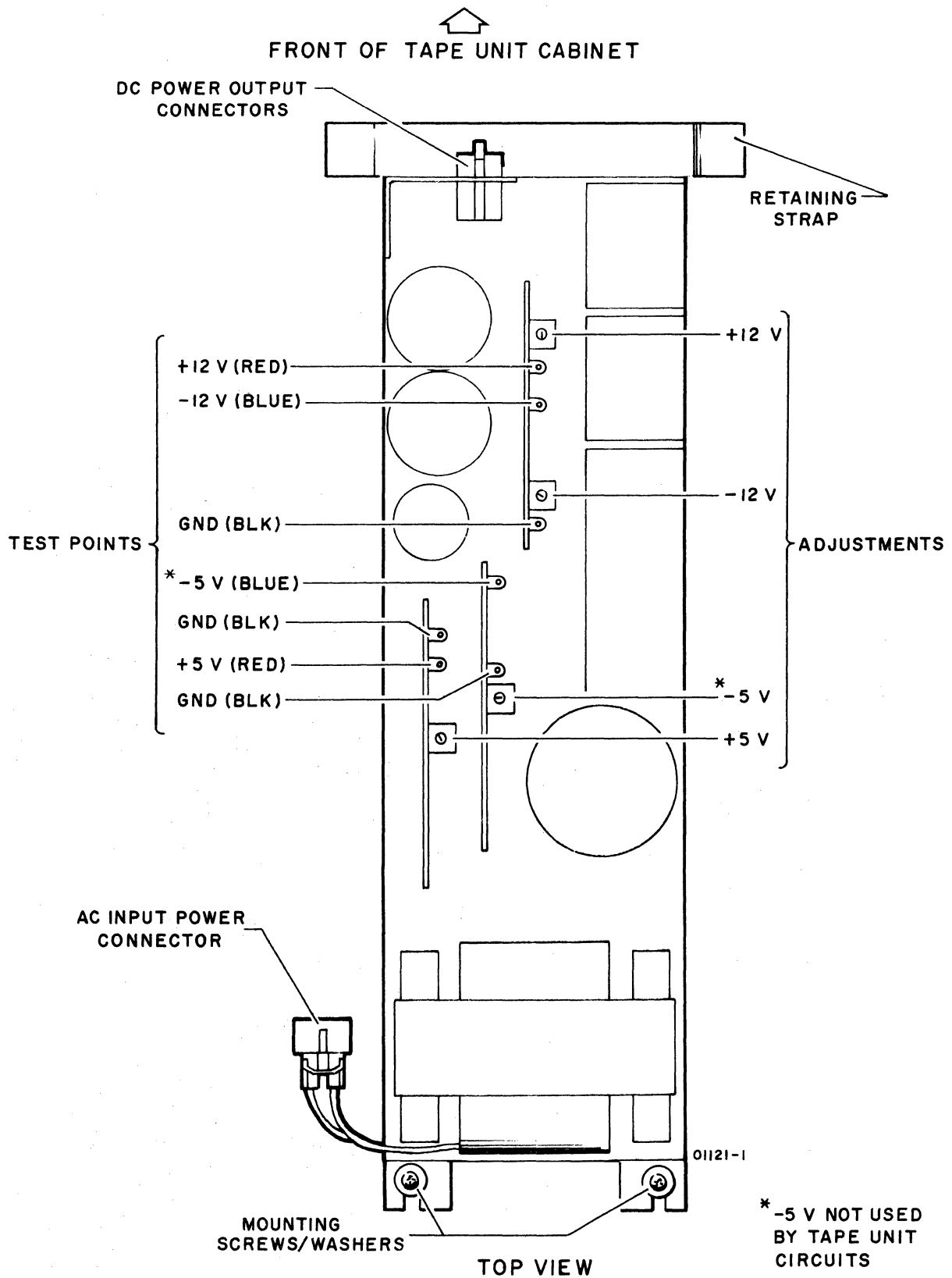

Figure TCU4. Power Supply (Test Points, Adjustments and Connections)

Procedure TCU7 — Removing/Replacing Power Supply Module

The power supply is considered as an on-site spare module (see Spare Parts List, section 8). If its output cannot be adjusted (procedure TCU6), remove and replace the entire power supply module as follows:

- 1) Press circuit breaker switch down to turn power off. Also disconnect ac power cord from site outlet.
- 2) Remove cabinet hood (procedure TCU4).
- 3) Disconnect ac input power connector at power supply transformer (figure TCU4). Also remove any cable tie from short cable to transformer.
- 4) Remove the two screws (with washers) which hold fan assembly mounting bracket down to chassis base just behind power supply, swing top of fan assembly/bracket toward power supply, and lift fan/bracket up and out of area behind power supply. Set fan/bracket aside in open area of cabinet near ac entry panel. Fan power cord can remain attached.
- 5) Remove the two mounting screws (with washers) which fasten transformer end of power supply base down in tape unit chassis base.
- 6) Slide power supply carefully back until front end mounting flange clears retaining strap which holds other end of power supply down in tape unit.
- 7) Disconnect both dc output power connectors at bracket (figure TCU4).
- 8) Grasp power supply firmly along its base sides and carefully lift transformer end up until it will pass through access hole where fan was and carefully slide it through access hole (being careful not to catch wiring). Set power supply on flat sturdy surface.

To replace the power supply, perform the preceding removal steps in reverse order. Be extremely careful though not to catch wires or have any squeezed under/by power supply base or fan mounting bracket when through replacing.

Procedure TCU8 — Removing/Replacing AC Entry Panel

The ac entry panel is considered as an on-site spare module (see Spare Parts List, section 8). If it is suspected of failure, remove and replace the entire ac entry panel module as follows:

- 1) Press circuit breaker switch down to turn power off. Also disconnect ac power cord from site outlet.
- 2) Remove cabinet hood (procedure TCU4).
- 3) Disconnect all safety ground wires from E2, E3, and E4 threaded lugs located inside top of ac entry panel box (figure TCU5, unscrew nuts from lugs to remove ground wire terminals).
- 4) Disconnect large power connector which is in short 3-wire cable which issues from inside top of ac entry panel box (figure TCU5).
- 5) Remove the four mounting screws which hold ac entry panel to back of cabinet, grasp loose panel, and pull it carefully out of its cutout in cabinet back.

To replace the ac entry panel, perform the preceding steps in reverse order.

Procedure TCU9 — Removing/Replacing Fan Assembly

The fan assembly is considered as an on-site spare module (see Spare Parts List, section 8). If it fails, remove the entire fan module as follows:

- 1) Press circuit breaker switch down to turn power off. Also disconnect ac power cord from site outlet.
- 2) Remove cabinet hood (procedure TCU4).
- 3) Carefully, but firmly, grasp each slide-on terminal of the two fan power wires (figure TCU5) singly (may grasp the insulated terminal with tapered-nose plier) and slide each terminal straight off of its mating power pin which protrudes from fan housing. Be careful not to bend terminals or pins.
- 4) Remove screw from cable clamp which holds the two fan wires at top of fan housing and remove cable clamp and the two wires from housing.

- 5) Remove the four mounting screws which hold fan assembly (and outer wire grill) to inside back of cabinet (figure TCU1), grasp freed fan assembly at top corners, and lift it out.
- 6) Note how the four metal fan-mounting clips are positioned and remove them from the four corners of fan housing and save them for mounting replacement fan.
- 7) Remove the four inner grill mounting screws from fan housing, remove inner wire grill, and remove the four mounting clips from these four corners of fan housing and save the clips, screws, and washers for mounting inner grill on replacement fan.

To replace the fan assembly, proceed as follows:

- 1) Place a mounting clip (saved from old fan) properly over each corner hole (eight) in the replacement fan housing.
- 2) Lay one wire grill over fan blade side of fan housing with side facing out which allows most fan blade clearance. Attach with flat washers, lockwashers, and screws saved from old fan.
- 3) Align outer wire grill, with concentric wire rings facing out toward back, over the four fan mounting screws which have been placed through their holes from back of tape unit cabinet.
- 4) Lower replacement fan assembly down in place with inner grill toward inside of tape unit cabinet and the two power pins at top corner by logic chassis. Start the four mounting screws which are already pushed through the four mounting loops of outer wire grill.
- 5) Making sure that fan assembly and outer wire grill fit snugly and squarely, tighten the four mounting screws until just snug. Do not overtighten or threaded clips will strip out.
- 6) Carefully work power wire terminals onto power pins which protrude from top corner of fan housing and attach cable clamp to other corner of housing such that it holds fan power wires neatly across top of housing.

Procedure TCU10 — Removing/Replacing LED Board

The LED board (figure TCU7) is considered as an on-site spare module (see Spare Parts List, section 8). If an LED appears burnt out, or otherwise is not working, remove and replace the LED board as follows:

- 1) Press circuit breaker switch down to turn power off. Also disconnect ac power cord from site outlet.
- 2) Remove cabinet hood (procedure TCU4).
- 3) Disconnect I/O connectors from rear panel.
- 4) Grasp cabinet firmly and tilt it up on either its left or right side and while holding there, remove the six large screws (with washers) from underside of cabinet (one by each foot pad and two at center) which hold entire metal chassis down in molded cabinet base. Be careful not to let chassis fall free of base when loose.
- 5) Lower entire unit to normal resting position on table.
- 6) Grasp metal chassis framework on each side near drive(s) and lift/work it up/free from cabinet base. Set freed chassis up on its side (either left or right as you prefer) on a firm, level surface (figure TCU7).
- 7) Use a short stubby screwdriver to remove the two LED board mounting screws (with washers) and gently work freed board out through bottom access opening in chassis until all pins on LED board are easily accessible (figure TCU7).
- 8) Hold replacement LED board alongside old board which is still wired in and, one-at-a-time, slide each wire terminal off old board and onto identical pin of new board. Do this for all wires.
- 9) With all wires transferred, position replacement board as old board was (green lights showing through READY and POWER indicator holes in front panel) and attach board with the two screws (with washers).
- 10) Remount chassis in cabinet base, etc. by doing preceding removal steps 1 through 6 in reverse order.

Procedure TCU11 — Checking/Replacing Front Panel Switches

To check/replace any front panel switch, proceed as follows:

- 1) Press circuit breaker switch down to turn power off. Also disconnect ac power cord from site outlet.
- 2) Remove cabinet hood (procedure TCU4).
- 3) Access suspect switch contacts by either reaching in with meter probes from open ends of front panel and/or by reaching in behind suspect switch and pressing/working it out of front panel until its contacts are accessible from outside front panel. Be careful not to bend or loosen any wire contacts on any switches when working behind front panel. If more access is preferred (such as to get at a middle switch), remove chassis from out of its cabinet base (procedure TCU10, steps 3 through 6). This allows access through large hole under LED board (figure TCU7).
- 4) Refer to figure TCU5 and check switch continuity as follows:

<u>Switch</u>	<u>Position</u>	<u>Pins Which Should Have Continuity (None Between All Any Others)</u>
RECORD/STBY/PLAY	RECORD	Center and Bottom
	STBY	None
	PLAY	Top and Center
ONLINE/LOCAL	ONLINE	Center and Bottom
	LOCAL	Top and Center
UNLOAD	Rest	None
	UNLOAD	Center and Bottom

Note: Center pin is ground for each switch.

If continuity different than this, while carefully noting their position for proper reconnection, slide wire contacts off suspect switch and check switch again. If still wrong, replace switch and connect wires to new switch exactly as was on old. If, however, suspect switch checks O.K. when disconnected but not when connected then a short exists in cabling (check per procedure TCU13) or in circuits cabled to. In such case, see table TCU1, DDLT for Tape Cassette Unit for troubleshooting.

- 5) After switch circuit checks O.K., verify all switches firmly seated in their cutout location in front panel, and verify all wires firmly connected to proper switch pins behind front panel. Also verify adequate clearance between terminals of all switch wires.
- 6) Return tape cassette unit to normal operation condition by doing preceding check/replace steps 1 through 3 in reverse order (includes remounting chassis, if removed, per procedure TCU10).

Procedure TCU12 — Removing/Replacing Tape Drive(s)

A tape drive (on either a single or dual tape drive unit) is considered as an on-site spare module (see Spare Parts List, section 8). It is not normally intended to be repaired at the customer site. Therefore, if a drive unit is faulty, remove and replace it as follows:

- 1) Press circuit breaker switch down to turn power off. Also disconnect ac power cord from site outlet.
- 2) Remove cabinet hood (procedure TCU4).
- 3) Release retaining clips and remove connector from back of suspect tape drive.
- 4) Remove those of the four tape drive mounting screws (figure TCU6) which are accessible without moving power supply. If lengths and types of screwdrivers available allow removing all four mounting screws (inside two are difficult to reach), skip to step 6. If not, do step 5.
- 5) Remove mounting screws of power supply and move it out of the way by using as many steps of procedure TCU7 as necessary to provide access to inside mounting screws of tape drive.
- 6) Grasp freed tape drive firmly by its exposed top sides and lift it carefully up/out of chassis being careful not to catch any wires. Set tape drive aside in a safe place.
- 7) Replace tape drive unit by doing preceding steps in reverse order. When installing the four mounting screws, just start all four at first without turning them snug. Then, evenly position drive unit front-to-back so front and back flanges rest equally even over cabinet cutout and, while holding drive in place, tighten the two outside mounting screws. This will keep drive from sliding in its mounting slots. Now, tighten the two inside mounting screws. If power supply was loosened and moved, return it (and fan assembly, if moved) to proper position.

To check any cable within the tape cassette unit cabinet, proceed as follows:

- 1) Press circuit breaker switch down to turn power off. Also disconnect ac power cord from site outlet.
- 2) Remove cabinet hood (procedure TCU4).
- 3) Refer to internal cable/connector diagram (figure TCU5) for cable general location/routing.
- 4) Visually inspect connections. If loose or open, secure, and if came to this procedure from a DDLT, return to the DDLT and check for results before proceeding with this procedure.
- 5) While carefully noting pin orientation/location so to enable proper reconnection (mark/tag if required), carefully disconnect both ends of suspect cable/wires.
- 6) Carefully inspect connector pins on both ends for possible damage. If damaged pin(s) found, replace pin(s), connector in which pin(s) reside, or entire cable (per steps 7 through 13 following) — whichever best meets existing spares availability and immediate customer needs.
- 7) Using the wiring list information (which appears along with the assembly drawing and parts list for each cable in section 7, Parts Data), do a pin-to-pin continuity check with an ohmmeter or continuity-checking idiot-light. If open wire found, repair if possible/desired (e.g., solder loose connection at connector or replace broken wire in bundle) or replace faulty cable with a new one per following steps.

To repair/replace a faulty cable within the tape cassette, proceed as follows:

- 8) After checking cable per preceding steps, remove any/all cable ties which may hold cable/wire in place. Make it a point to remember where such ties were placed for proper re-tying later.
- 9) Carefully work entire length of cable (and attached connectors) free from its route and out of chassis.
- 10) Verify having correct replacement cable (see Parts Data, section 8).
- 11) Carefully work cable (and attached connectors) into its proper place.
- 12) Secure new cable as required with cable ties.
- 13) Carefully reconnect connections properly.
- 14) Close hood and/or apply power (procedure TCU1) as desired.

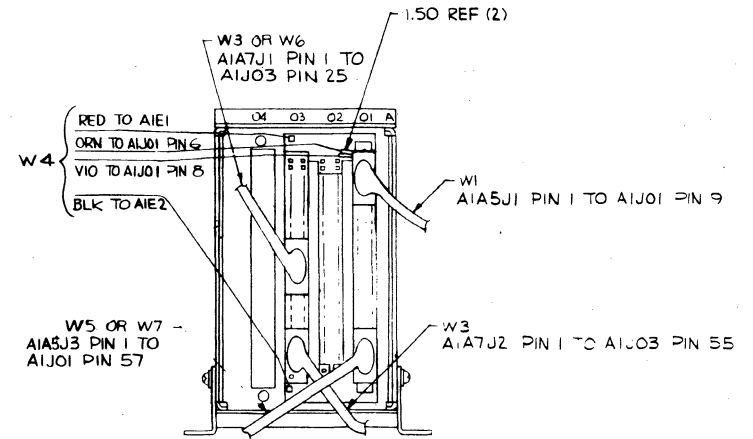
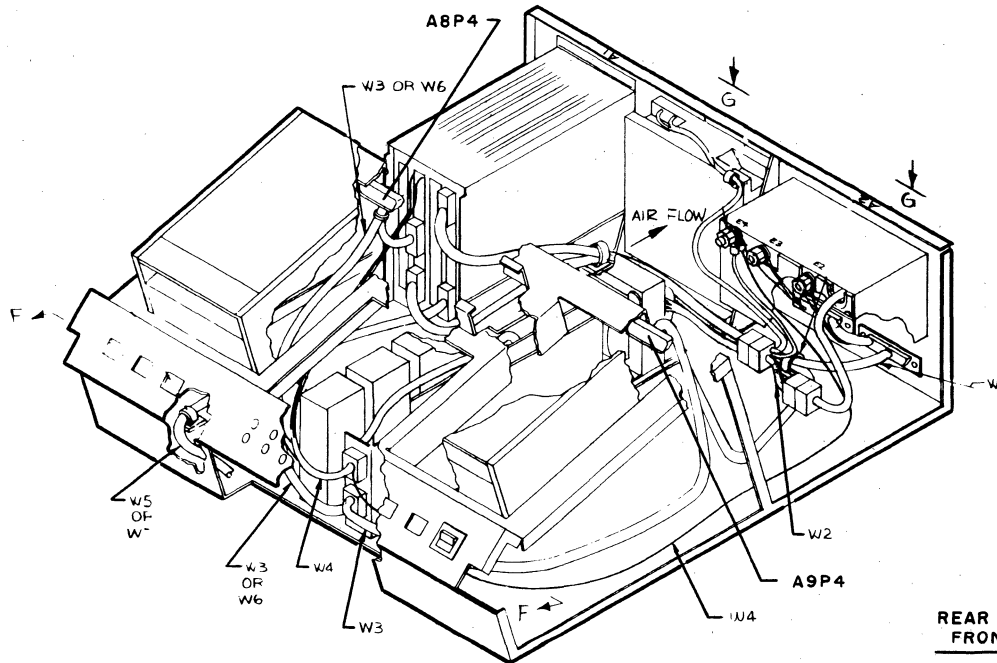

REAR VIEW OF A1
ROTATED CCW INTO VIEW

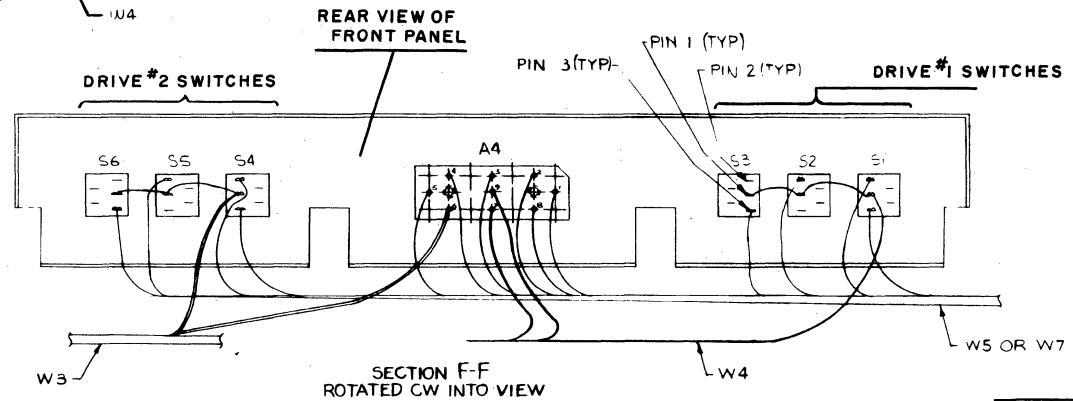
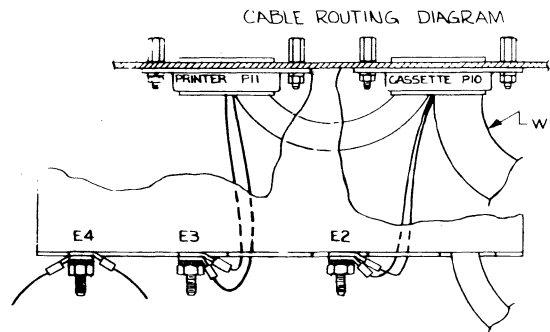

SECTION F-F
ROTATED CW INTO VIEW

CODE IDENT 15920	QWG NO D	REV 15627600	A
SHEET 3			

Figure TCU5. Cable Routing Diagram

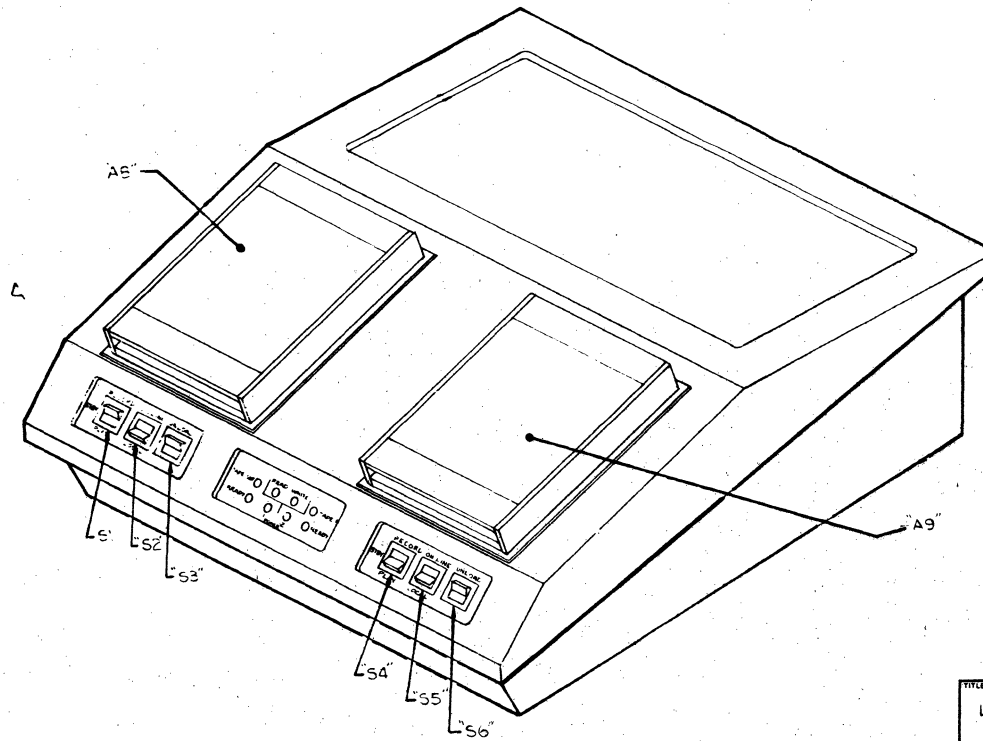

TITLE		
LIAT TAPE CASSETTE ASSY		
CODE IDENT	D	DRAWING NO
15920		15627600
		THRU
		15627605
SCALE NONE	EC 15627500	SHEET 1 OF 3

Figure TCU6. Tape Cassette Unit Composition (Sheet 1 of 2)

62962300 A

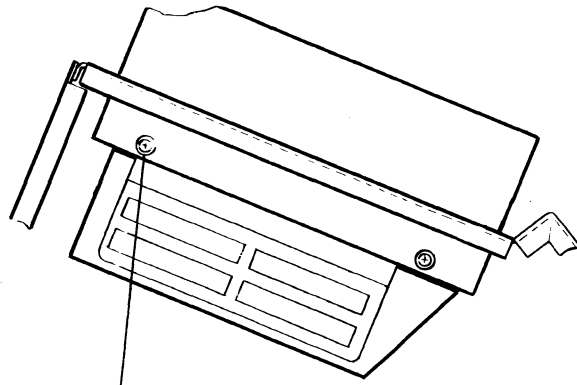

TAPE DRIVE MOUNTING SCREWS
(4 EACH UNIT)

VIEW C-C

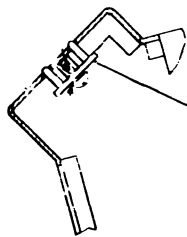

"A4" LED BOARD

SECTION D-D

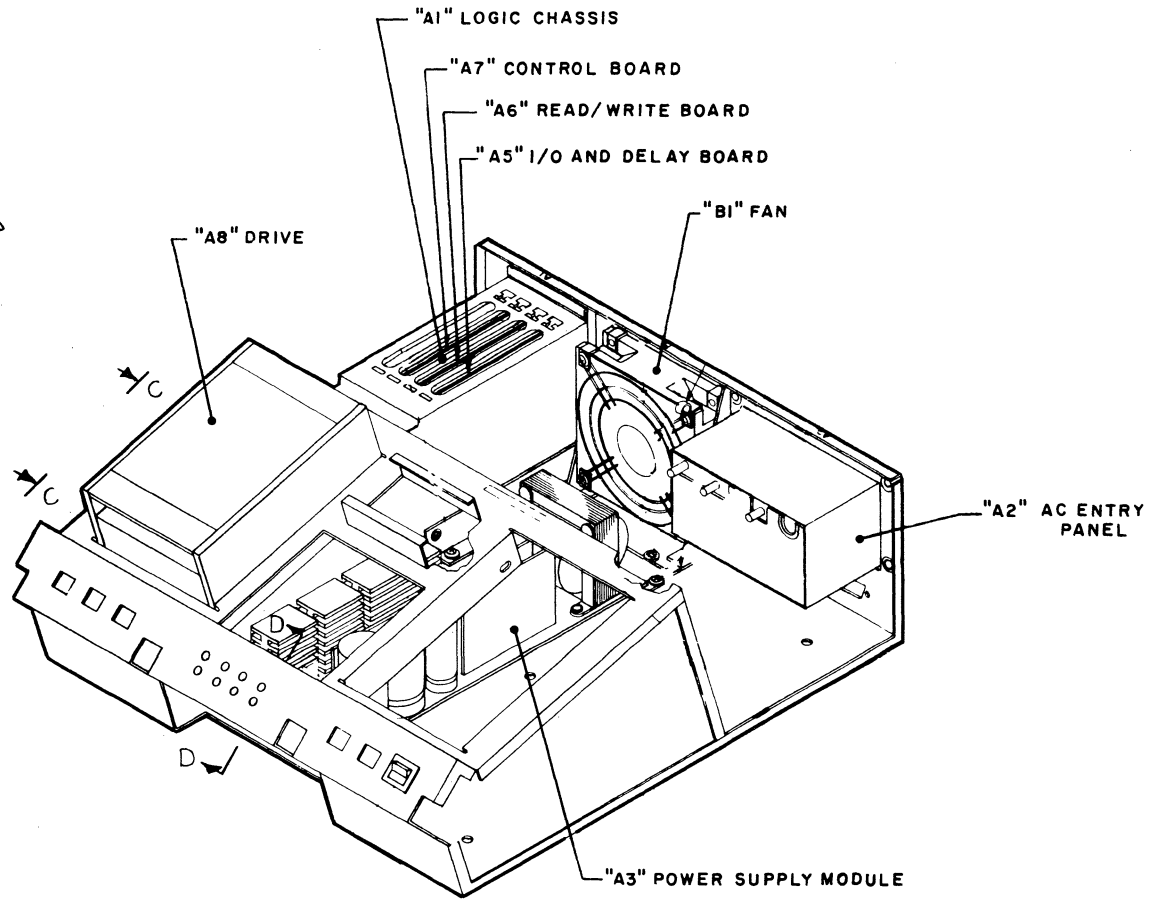

CASSETTE WITHOUT BASE,
HOOD, BEZEL
AND CABLES

CDR IDENT	DWG. NO.	REV.
15920	D 15627600	A
SHEET 2		

Figure TCU6. Tape Cassette Unit Composition (Sheet 2 of 2)

6E-19

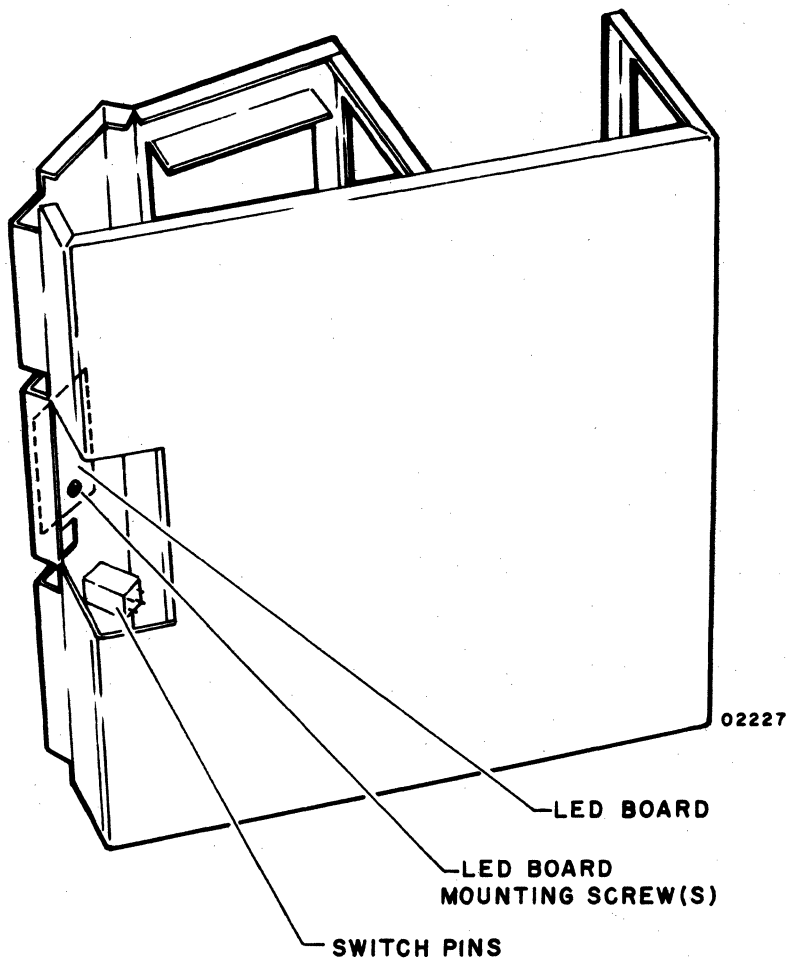

Figure TCU7. Bottom View of Chassis (Removed From Cabinet Base)

Procedure TCU14 — Cleaning Tape Drive Mechanism

Clean each tape cassette drive as follows:

- 1) Open cassette holder and, if loaded, remove cassette.

CAUTION

Do not use an abrasive or a metallic objective for cleaning head assembly. Such instruments may nick or scratch head surface.

- 2) Moisten a cotton swab with a quality magnetic tape head cleaner and carefully swab tape-contacting face of head (figure TCU8) to remove accumulated dust and oxide. As swab becomes dirty with oxide from magnetic head, discard and use clean swab. Continue cleaning until swab remains clean.
- 3) Use another swab, rub pinch roller up and down, while rotating pinch roller at same time. Continue rubbing and rotating pinch rollers with swabs until swabs remain clean.
- 4) Next clean the two capstans with same up and down rubbing as for pinch rollers.
- 5) Using another swab, clean BOT/EOT hole lamp, BOT/EOT sensor, tape guides and guide pins.
- 6) With a dry swab wipe head, rollers, and all areas cleaned to dry up any remaining cleaner.

NOTE

Remove any lint that might remain in transport from a cotton swab.

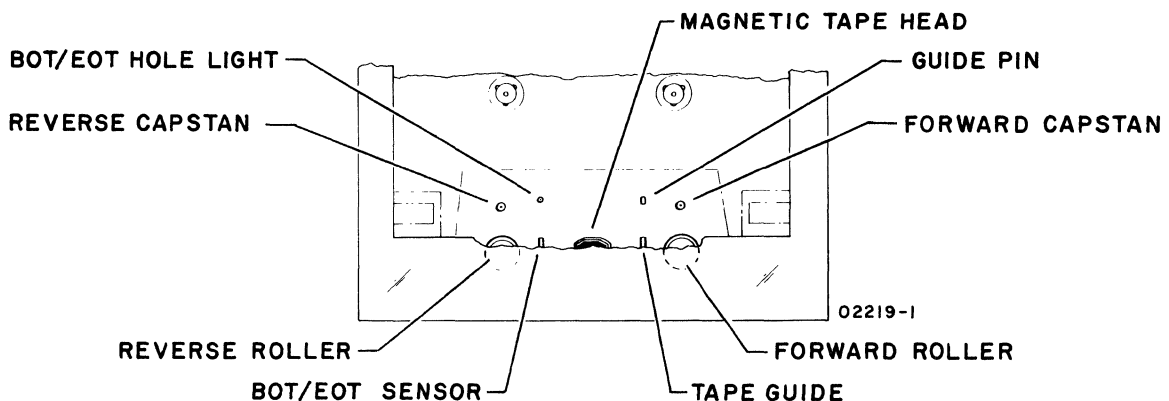
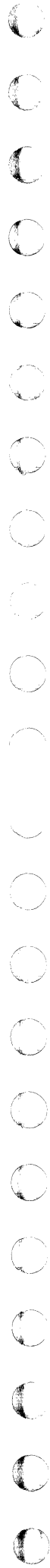

Figure TCU8. Locations of Magnetic Tape Head, Capstans, and Rollers



INDEX

SUBSYSTEM TEST MODE DIAGNOSTIC 6-14

IMPACT PRINTER TEST PRINT DIAGNOSTIC 6-16

POWER SEQUENCE

Turning On Subsystem Power 6A-2

Turning Off Subsystem Power 6A-3

TERMINAL SUBSYSTEM PROCEDURES

<u>Procedure</u>	<u>Page</u>	<u>Procedure</u>	<u>Page</u>	<u>Procedure</u>	<u>Page</u>
TS1	6A-2	TS3	6A-4	TS-5	6A-5
TS2	6A-3	TS4	6A-4		

<u>Figure</u>	<u>Page</u>	<u>Table</u>	<u>Page</u>
None		TS1	6A-1

KEYBOARD DISPLAY (CRT) TERMINAL

<u>Procedure</u>	<u>Page</u>	<u>Procedure</u>	<u>Page</u>	<u>Procedure</u>	<u>Page</u>
CRT1	6B-19	CRT12	6B-33	CRT23	6B-63
CRT2	6B-19	CRT13	6B-38	CRT24	6B-64
CRT3	6B-19	CRT14	6B-40	CRT25	6B-68
CRT4	6B-22	CRT15	6B-43	CRT26	6B-70
CRT5	6B-24	CRT16	6B-48	CRT27	6B-81
CRT6	6B-26	CRT17	6B-49	CRT28	6B-82
CRT7	6B-27	CRT18	6B-51	CRT29	6B-83
CRT8	6B-28	CRT19	6B-52	CRT30	6B-87
CRT9	6B-29	CRT20	6B-54	CRT31	6B-96
CRT10	6B-31	CRT21	6B-58	CRT32	6B-98
CRT11	6B-31	CRT22	6B-59		



KEYBOARD DISPLAY (CRT) TERMINAL (CONTD)

<u>Figure</u>		<u>Page</u>	<u>Figure</u>		<u>Page</u>	<u>Figure</u>		<u>Page</u>
CRT1	6B-20	CRT23	6B-45	CRT45	6B-74
CRT2	6B-21	CRT24	6B-46	CRT46	6B-75
CRT3	6B-23	CRT25	6B-49	CRT47	6B-76
CRT4	6B-24	CRT26	6B-50	CRT48	6B-76
CRT5	6B-25	CRT27	6B-52	CRT49	6B-77
CRT6	6B-26	CRT28	6B-53	CRT50	6B-79
CRT7	6B-27	CRT29	6B-54	CRT51	6B-80
CRT8	6B-28	CRT30	6B-55	CRT52	6B-84
CRT9	6B-30	CRT31	6B-56	CRT53	6B-85
CRT10	6B-31	CRT32	6B-57	CRT54	6B-86
CRT11	6B-32	CRT33	6B-60	CRT55	6B-88
CRT12	6B-33	CRT34	6B-62	CRT56	6B-90
CRT13	6B-34	CRT35	6B-64	CRT57	6B-90
CRT14	6B-35	CRT36	6B-65	CRT58	6B-91
CRT15	6B-36	CRT37	6B-66	CRT59	6B-92
CRT16	6B-37	CRT38	6B-67	CRT60	6B-93
CRT17	6B-38	CRT39	6B-68	CRT61	6B-94
CRT18	6B-39	CRT40	6B-69	CRT62	6B-95
CRT19	6B-42	CRT41	6B-69	CRT63	6B-97
CRT20	6B-43	CRT42	6B-71	CRT64	6B-99
CRT21	6B-44	CRT43	6B-73	CRT65	6B-100
CRT22	6B-45	CRT44	6B-74			

<u>Table</u>		<u>Page</u>	<u>Table</u>		<u>Page</u>	<u>Table</u>		<u>Page</u>
CRT1	6B-1	CRT5	6B-12	CRT9	6B-16
CRT2	6B-9	CRT6	6B-13	CRT10	6B-17
CRT3	6B-10	CRT7	6B-14	CRT11	6B-18
CRT4	6B-11	CRT8	6B-15	CRT12	6B-99

NONIMPACT PRINTER

<u>Procedure</u>		<u>Page</u>	<u>Procedure</u>		<u>Page</u>	<u>Procedure</u>		<u>Page</u>
NIP1	6C-3	NIP6	6C-10	NIP11	6C-20
NIP2	6C-5	NIP7	6C-14	NIP12	6C-21
NIP3	6C-5	NIP8	6C-17	NIP13	6C-22
NIP4	6C-8	NIP9	6C-17			
NIP5	6C-10	NIP10	6C-18			

<u>Figure</u>		<u>Page</u>	<u>Figure</u>		<u>Page</u>	<u>Figure</u>		<u>Page</u>
NIP1	6C-4	NIP5	6C-11	NIP9	6C-19
NIP2	6C-6	NIP6	6C-16	NIP10	6C-21
NIP3	6C-7	NIP7	6C-16			
NIP4	6C-8	NIP8	6C-18			



NONIMPACT PRINTER (CONTD)

<u>Table</u>		<u>Page</u>	<u>Table</u>		<u>Page</u>
NIP1	6C-1	NIP2	6C-17

IMPACT PRINTER

<u>Procedure</u>	<u>Page</u>	<u>Procedure</u>	<u>Page</u>	<u>Procedure</u>	<u>Page</u>
IMP1 6D-6	IMP7 6D-16	IMP13 6D-25
IMP2 6D-8	IMP8 6D-17	IMP14 6D-26
IMP3 6D-8	IMP9 6D-19	IMP15 6D-33
IMP4 6D-11	IMP10 6D-19	IMP16 6D-33
IMP5 6D-13	IMP11 6D-20	IMP17 6D-34
IMP6 6D-15	IMP12 6D-21		

<u>Figure</u>	<u>Page</u>	<u>Figure</u>	<u>Page</u>	<u>Figure</u>	<u>Page</u>
IMP1 6D-10	IMP7 6D-18	IMP13 6D-29
IMP2 6D-12	IMP8 6D-22	IMP14 6D-30
IMP3 6D-12	IMP9 6D-23	IMP15 6D-31
IMP4 6D-14	IMP10 6D-24	IMP16 6D-32
IMP5 6D-14	IMP11 6D-27		
IMP6 6D-17	IMP12 6D-28		

<u>Table</u>	<u>Page</u>
IMP1 6D-1

TAPE CASSETTE UNIT (TCU)

<u>Procedure</u>	<u>Page</u>	<u>Procedure</u>	<u>Page</u>	<u>Procedure</u>	<u>Page</u>
TCU1 6E-3	TCU6 6E-8	TCU11 6E-14
TCU2 6E-4	TCU7 6E-10	TCU12 6E-15
TCU3 6E-5	TCU8 6E-11	TCU13 6E-16
TCU4 6E-6	TCU9 6E-11	TCU14 6E-21
TCU5 6E-7	TCU10 6E-13		

<u>Figure</u>	<u>Page</u>	<u>Figure</u>	<u>Page</u>	<u>Figure</u>	<u>Page</u>
TCU1 6E-4	TCU4 6E-9	TCU7 6E-20
TCU2 6E-5	TCU5 6E-17	TCU8 6E-21
TCU3 6E-7	TCU6 6E-18		

<u>Table</u>	<u>Page</u>
TCU1 6E-1



This appendix supplements the 62962300 Hardware Maintenance 751-10 Terminal Subsystem manual by describing the 70-LPM Impact Printer. Information given here parallels the present manual breakdown of printer information. Any material not covered in this appendix can be found in the Field Service and Reference manual 95445028 (Parts Identification Manual is 95445025). See Vol. 1 of this manual for general description and specifications relating to the 70-LPM Impact Printer.

Here follows the arrangement of this appendix:

INSTALLATION AND CHECKOUT

- o Uncrating 70-LPM Impact Printer
- o Installation and Checkout
 - o Checking Supplemental Function Modules
 - Printer Interface Control
 - o Installation
 - o Checkout

MAINTENANCE

- o Preventative Maintenance
 - o 70-LPM Impact Printer PMT's
 - o 70-LPM Impact Printer PMTP's
- o Diagnostic and Corrective Maintenance
 - o 70-LPM Impact Printer Test Print Diagnostic Tables Corrective Maintenance Procedures

Appendix F provides information on printer supplies and format tape punching.

INSTALLATION AND CHECKOUT

UNCRATING

The following paragraphs describe uncrating procedures for the 70-LPM impact printer, PC card modules, and miscellaneous printer components.

70-LPM IMPACT PRINTER

To uncrate the 70-LPM printer, refer to figure A-1 and perform the following steps:

- 1) Cut and remove the steel strapping holding shipping container to skid.
- 2) Open top of shipping container and remove manuals and cabling on top of printer top cushion.
- 3) Remove top cushion from top of printer.
- 4) Remove dust cover from printer by pulling it up and off of printer.

CAUTION

The 70-LPM printer weighs approximately 100 lb (45.4 kg). Get assistance to remove printer from shipping container to prevent possible bodily injury and/or damage to the printer.

- 5) Carefully lift printer from shipping container and place it on a solid, level surface.
- 6) Remove filament tape and any wrapping or packing material used to secure printhead and paper weights during shipment.
- 7) Remove two M6x8 machine screws that secure the floating printer mechanism to printer base plate. These screws are accessible from bottom of the printer; however, do not tip printer up on its cabinet to access these screws. Overhang one end of the printer at a time from a stable workbench or table to reach these shipping screws.
- 8) Inspect printer for possible damage during transit.

To protect against shipping damage, always prepare an equipment for shipment using only approved procedures and materials. To obtain proper procedures and materials, contact your nearest CDC representative or:

Control Data Corporation
Corporate Traffic
8100 34th Avenue South
Minneapolis, Minnesota 55440

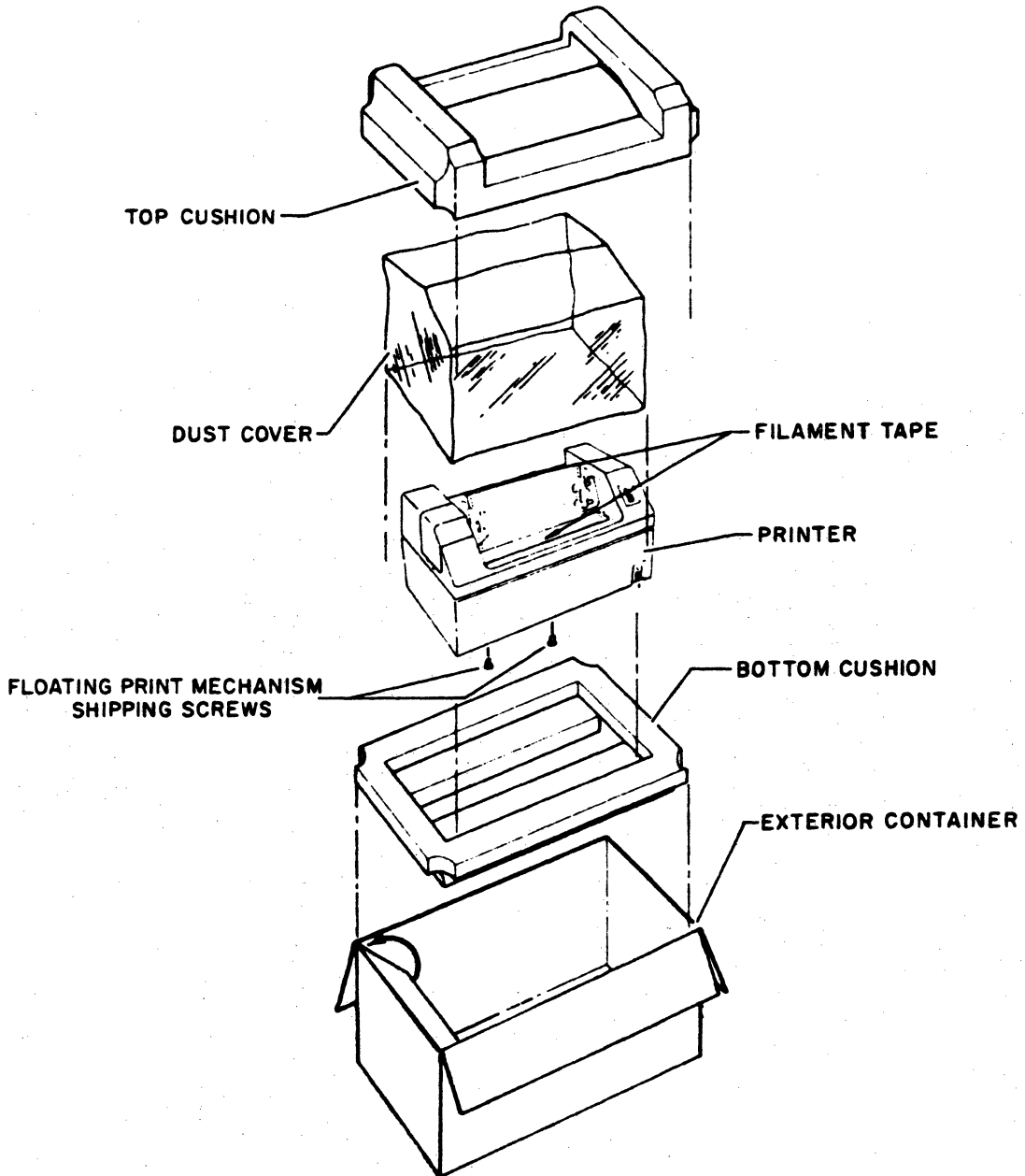

Figure A-1. Crating and Uncrating the 70-LPM Impact Printer

PC CARD MODULES

To unpact any circuit modules, refer to the Installation and Checkout section, of the existing manual (Vol. 2).

MISCELLANEOUS PRINTER COMPONENTS

When unpacking any replacement components for 70-LPM printer, always proceed carefully and remember the following:

- 1) Preserve the condition of the shipping container and packing material for later use in returning a malfunctioning component or equipment for repair.
- 2) Observe the manner in which a received item is packed so that the return item can be packed in a similar manner.

INSTALLATION AND CHECKOUT

70-LPM Impact Printer Interface Control

Refer to the text in Vol. 2 of current manual (no. 62962300) under same heading for information.

70-LPM IMPACT PRINTER INSTALLATION

Install the 70-LPM printer on a level surface, so that the printer weight is resting evenly over all four rubber feet.

If the printer is to be installed on a table, bench, or cabinet, level the top surface before placing the printer on it. In general, the printer will operate on a fairly level surface as long as it is not allowed to rock. The main reason for requiring that the printer be level is for form feed purposes.

The following procedure gives the steps for installing the 70-LPM printer.

CAUTION

The 70-LPM printer weighs approximately 100 lb (45.4 kg). Be careful when lifting or moving the printer so as not to injure yourself or damage the printer.

- 1) Remove the printer unit from shipping container according to the preceding uncrating instructions.
- 2) Place the printer unit near its associated keyboard display terminal. Ensure that surface on which printer is placed is firm, stable and level, and that there is space around printer for performing routine maintenance and operating tasks. The spacing shown in figure A-2 is recommended as a minimum.

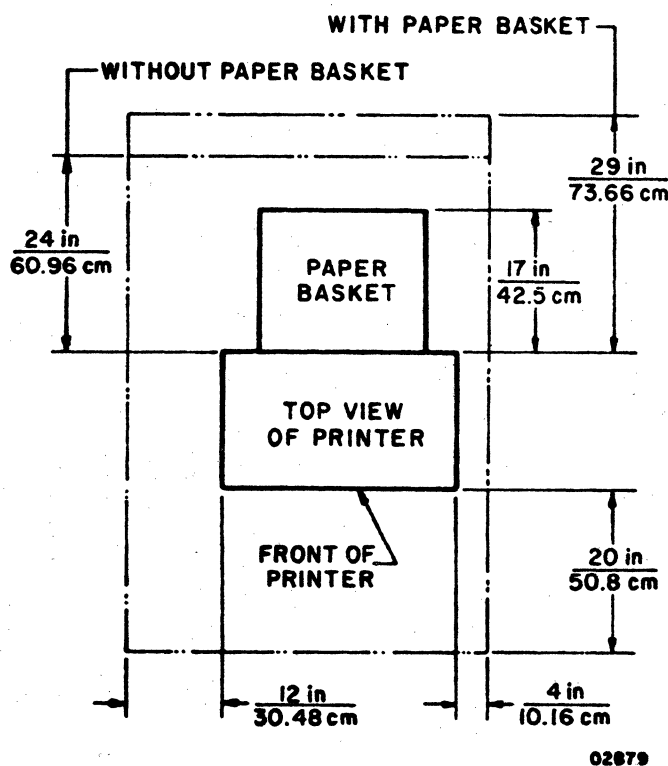
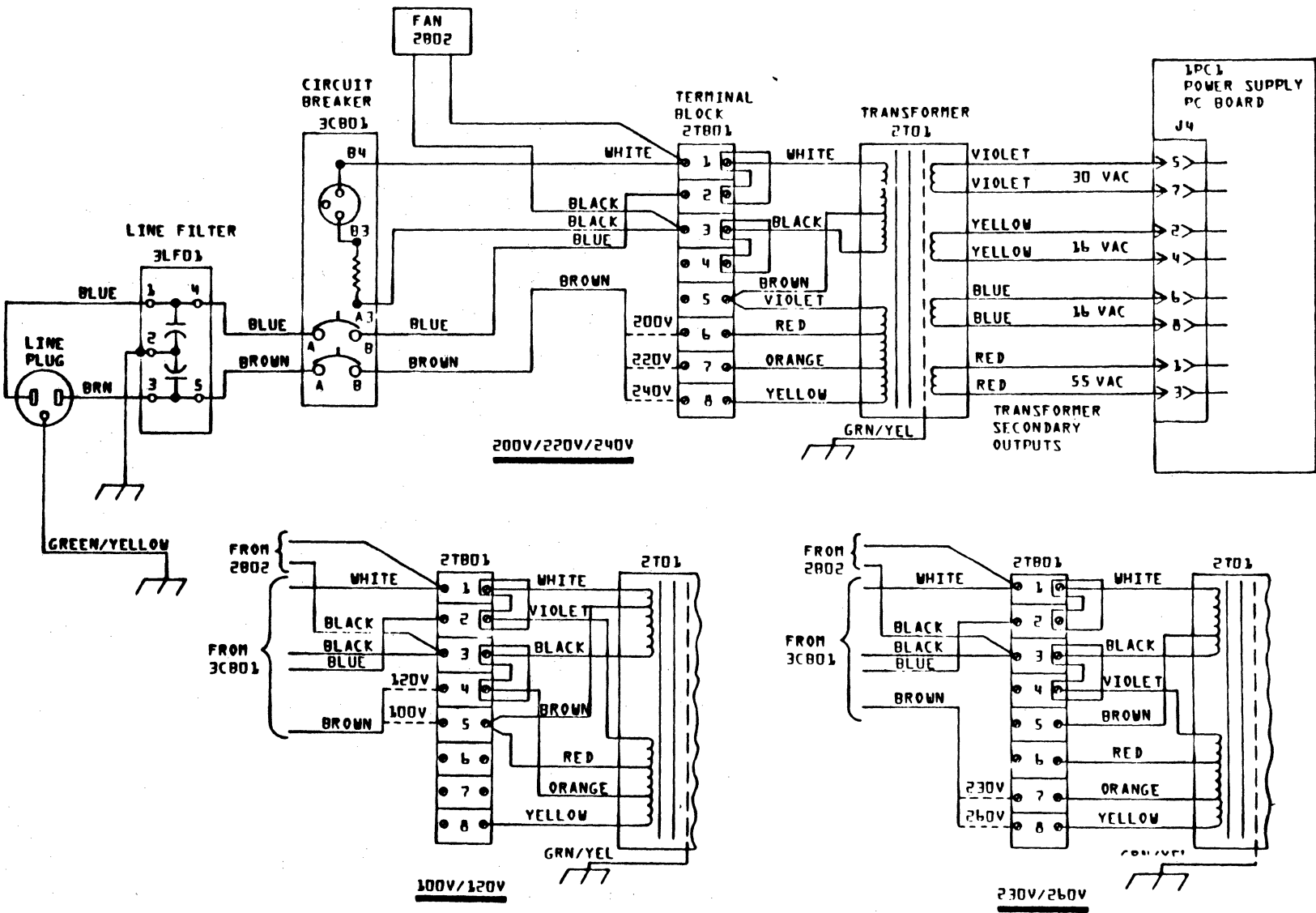

Figure A-2. Printer Dimensions

- 3) Remove upper cabinet cover, side cover, and front cover of printer (refer to specific cover removal and replacement procedures).

- 4) Swing down interface adapter frame and PC board, mounted vertically at rear of printer, by releasing plastic latch at each upper end of frame and letting top edge of frame down until frame is horizontal.
- 5) Swing down controller and printhead PC board (next board in from rear of printer chassis) in the same manner as used for the adapter interface board in the preceding step.
- 6) Swing down the power supply PC board (3rd board in from rear of printer) in same manner as used in steps 4 and 5.
- 7) Measure ac voltage level at site power outlet with an ac voltmeter, and ensure that power wiring between circuit breaker 3CB01, terminal block 2TB01, and the primary of input transformer 2T01 is appropriately connected for the measured input voltage level. The circuit breaker, terminal block, and input power transformer are all located near the right side of the printer chassis from the front. The input power transformer has connections for voltage input levels of 100, 120, 200, 220, 240, and 260 V ac; see figure A-3 and alter input power wiring as necessary to most closely match available input power (measured voltage level).
- 8) If 50-Hz power is the only input power available at site, clip off standard 60-Hz input power plug and replace it with an appropriate 50-Hz power plug. See figure A-3 for color coding and terminal wiring of input power cord wires and transformer.
- 9) Swing power supply PC board back up into printer chassis. Ensure that board latches engage the proper holes in chassis frame and that board is securely held in chassis in a vertical position.



62962300 D

- 10) Locate switch bank SWN4 on controller and printhead PC board (approximately location F6 on board), and set eight SWN4 switches as follows (figure A-4):

SWITCH	FUNCTION
SWN4-1	ELONGATED CHARACTER FEATURE
SWN4-2	AUTOMATIC LINE FEED FEATURE
SWN4-3	SPARE (NOT USED)
SWN4-4	SPARE (NOT USED)
SWN4-5	80 COLUMN FEATURE
SWN4-6	AUTOMATIC DOUBLE SPACE FEATURE
SWN4-7	AUTOMATIC TERMINATE FEATURE
SWN4-8	INTERACTIVE MODE FEATURE

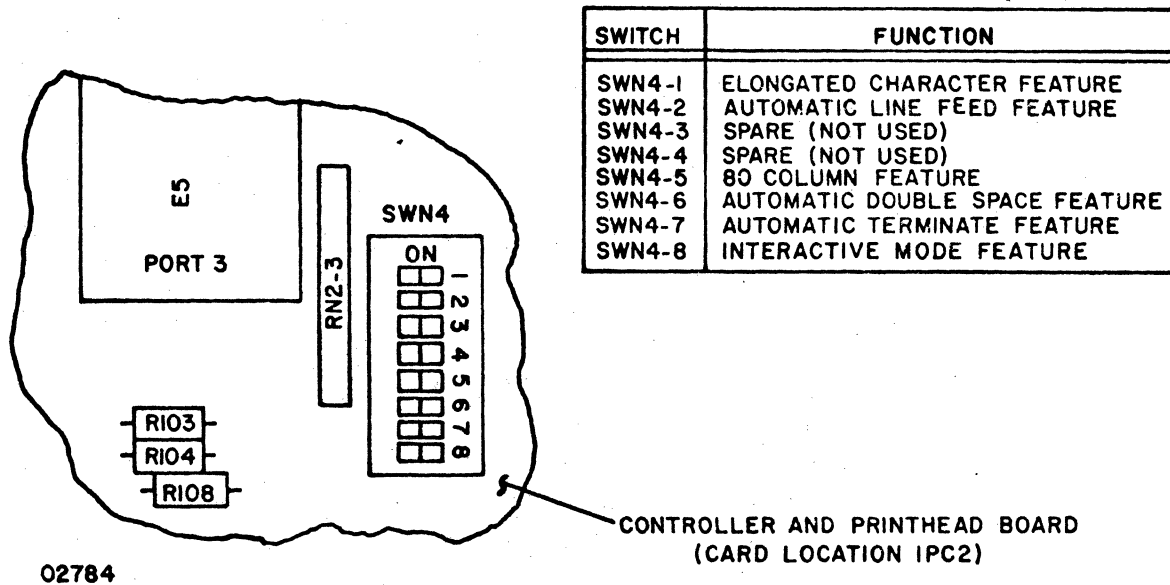

Figure A-4. Location and Functions of SWN4 Switches

- 11) Swing controller and printhead board back up into printer chassis. Ensure that board latches engage proper holes in chassis frame so that board is securely held in chassis in a vertical position.

- 12) Using figure A-5 as a guide, set the printer baud rate and parity select switches, located in the interface adapter PC board, to match those of the keyboard display (refer to Installation Instructions, appendix A, of the existing manual for Keyboard Display Installation procedure). Baud rate for terminals using a 70-LPM printer should not exceed 2400 baud.
- 13) Set data bit switches and jumper on interface adapter PC board (see figure A-5) to correspond with parity selection made in preceding step: if odd or even parity is selected, select 7 data bits; if no parity is selected, select 8 data bits.
- 14) Remove interface adapter board jumpers for auto answering and reverse channel; alarm jumpers and buffer overflow jumper removal is selective (user determined).
- 15) Swing interface adapter PC board and frame back up into printer chassis. Ensure that board latches engage proper holes in chassis frame so that board is securely held in chassis in a vertical position.
- 16) Check to see that format tape is properly installed in electronic vertical format unit (EVFU) drive mechanism, which is located on left side (from front) of printer chassis. If format tape requires punching, refer to Format Tape Punching procedure. If format tape requires installation, refer to Format Tape Load Operation procedure.
- 17) Set printer ON/OFF power switch to OFF position, and remove printer ac power plug from site outlet.
- 18) Install printer cabinet (refer to specific cover removal and replacement procedure).
- 19) Plug printer power cord in appropriate site ac power outlet.
- 20) Unpack the printer paper basket by removing the two-piece basket, the grounding strip bracket assembly, the bag of assembly hardware, and the basket assembly instructions from shipping container.
- 21) Check parts against the assembly instructions to ensure that none of the paper basket parts are missing or damaged.
- 22) Mount the grounding strip bracket assembly to printer base plate (refer to Paper Basket Operation procedure).

- 23) Connect RS-232-C/CCITT V.24 type I/O cable from rear of display terminal PERIPHERAL CONNECTOR to printer rear panel connector.
- 24) Plug printer power cord in appropriate site outlet.

70-LPM IMPACT PRINTER CHECKOUT

Included in the check items for the 70-LPM printer are checks of the printer forms (paper) supply and print quality. The following are initial preparation checks for the 70-LPM printer.

- 1) Ensure printer ON/OFF switch is in the OFF position. Plug printer into its power outlet.
- 2) Install ribbon cassette to printhead (if not done already, refer to Ribbon Cassette Replacement procedure).
- 3) Install forms and lower necessary paper weights (refer to Forms Installation and Alignment procedure).
- 4) Power on the printer. To operate printer with cabinet removed, the interlock switch, left of the control panel, is pulled up.

CAUTION

If diagnostic routines are performed that require continuous column printing, the duration should be limited to 5 minutes (maximum) or damage will result to the solenoid assemblies.

- 5) Actuate TEST PRINT switch located on the controller and printhead board. This switch causes the printer to print the character B, alternating with blanks across the page and then performs a single line advance. Use this pattern to check vertical and horizontal alignment of the forms.
- 6) Actuate TEST PRINT switch. A second actuation terminates the test print operation.
- 7) Check out the 6/8-LPI switch setting and the 10/16.5-CPI switch setting.

Do not actuate the 6/8-LPI switch or the 10/16.5-CPI switch when the printer is printing in the test print mode. Terminate test print operation, actuate 10/16.5-CPI switch and reenter the test print mode.

- 8) Load format tape into reader (refer to Format Tape Load Operation procedure). Actuate LOAD EVFU switch and load format tape into memory. Press FORM FEED switch on the control panel. The printer should slew paper to the top of the form.
- 9) Power off the printer by placing ON/OFF switch in the OFF position. Remove forms from printer.
- 10) Replace lower cabinet skirt and all covers (refer to specific removal and replacement procedure).
- 11) Power on the printer.
- 12) Load forms
- 13) Reload format tape into memory.
- 14) Install interface cable and actuate the START/STOP switch. The switch illuminates and the printer is ready for online operation.

PREVENTIVE MAINTENANCE (70-LPM IMPACT PRINTER)

Preventive maintenance describes those tasks that are performed immediately following and as part of an emergency maintenance call. Preventive maintenance task tables (PMT) and preventive maintenance task procedures (PMTP) define the particular tasks to be performed for a terminal, indicate the schedule for performing these tasks, and describe how to do these tasks. Both PMTs and PMTPs for each equipment that can be used to configure this terminal subsystem are included in this section. While a CE is performing the PMTs and PMTPs, they should verify that the terminal operator has been performing their assigned preventive maintenance tasks. Normally, a terminal operator is only responsible for routine cleaning of equipment exterior; however, in some instances, the operator may be responsible for more complex preventive maintenance procedures. This is often determined on a per-installation basis and on the type of operator personnel used at a given installation.

IMPACT PRINTER PMTs (70-LPM)

The PMTs listed in table 70-1 are the tasks to be done at the impact printer (if a part of the subsystem) at the intervals specified in the table. Do these tasks for best equipment performance and to reduce repairs.

IMPACT PRINTER PMTPs (70-LPM)

The following text describes the PMTPs which support the preceding PMT table for the impact printer.

CAUTION

Before working inside of the cabinet for these PMTPs, turn power off and remove ac input cord from site power outlet.

The following steps describe the level 1 tasks listed in the PMT table.

- 1.1) Clean exterior surfaces of cabinet with damp lint-free cloth. Mild detergent may be used. Do not use cloth so wet that water runs down into printer.
- 1.2) Remove cabinet (procedure 70-6). With cabinet placed aside, inspect interior cabinet base and horizontal surfaces for parts which may have worked loose from mechanism. Replace parts, or mechanism, depending on whether loose parts are reusable, replaceable, etc.

TABLE A-1. IMPACT CHARACTER PRINTER PMTS

LEVEL (SEE NOTE 1)	ITEM	PROCEDURE	APPROXIMATE TIME (SEE NOTE 2)
1	1.1	Clean exterior surface	3
1	1.2	Inspect cabinet interior for loose parts	5
1	1.3	Clean cabinet interior	5
1	1.4	Inspect all cables and wires for insulation breakdown or other damage	4
1	1.5	Inspect all mechanisms for signs of excess wear	5
1	1.6	Check carefully for foreign objects inside cabinet and mechanism	4
2	2.1	Apply oil to oiler pad	2
2	2.2	Inspect printhead drive belt and printhead motor belt	3
2	2.3	Examine ribbon cassette drive cord	2
2	2.4	Clean printhead-slide shafts	2
2	2.5	Do test print exercise	5
2	2.6	Replace cabinet and pack tools/materials	10

NOTES:

1) LEVEL 1 TASKS ARE THOSE TO BE DONE EACH TIME THE TERMINAL SUBSYSTEM REQUIRES REPAIR. LEVEL 2 TASKS ARE REQUIRED EVERY 13.2 MILLION PRINTED CHARACTERS OR 1300 HOURS OF POWER-ON TIME, WHICHEVER COMES FIRST. HOWEVER, IF INSPECTION SHOWS LEVEL 2 TASKS SHOULD BE DONE AHEAD OF SCHEDULE, DO THEM AS FOUND NECESSARY.

2) APPROXIMATE TIME GIVEN IS IN MINUTES, AND IS FOR TASKS LISTED HERE ONLY. THIS DOES NOT INCLUDE CORRECTIVE MAINTENANCE PROCEDURES WHICH MAY BE SEEN AS NECESSARY FROM THESE PMTS.

- 1.3) Using a soft, long-bristled brush and vacuum cleaner with a crevice tool, carefully and thoroughly clean cabinet interior of any/all paper particles, dust, etc.
- 1.4) Inspect all cables, wires, and connections (including input/output connector pins) for evidence of insulation breakdown or wear. Repair/replace damaged wires if possible. Check electronic components for signs of deterioration caused by overheating or aging.
- 1.5) Look carefully at all mechanisms for signs of wear. Repair/replace worn parts if possible (use replacement procedures provided later in this section).
- 1.6) Inspect for foreign objects possibly lodged in crevices within the mechanism or other portions of the equipment.

The following steps describe the level 2 tasks listed in the PMT table. However, perform all level 1 tasks before doing level 2.

- 2.1) Apply three or four drops of oil (CDC part number 95370201) in hole at top of oiler pad (figure A-1).

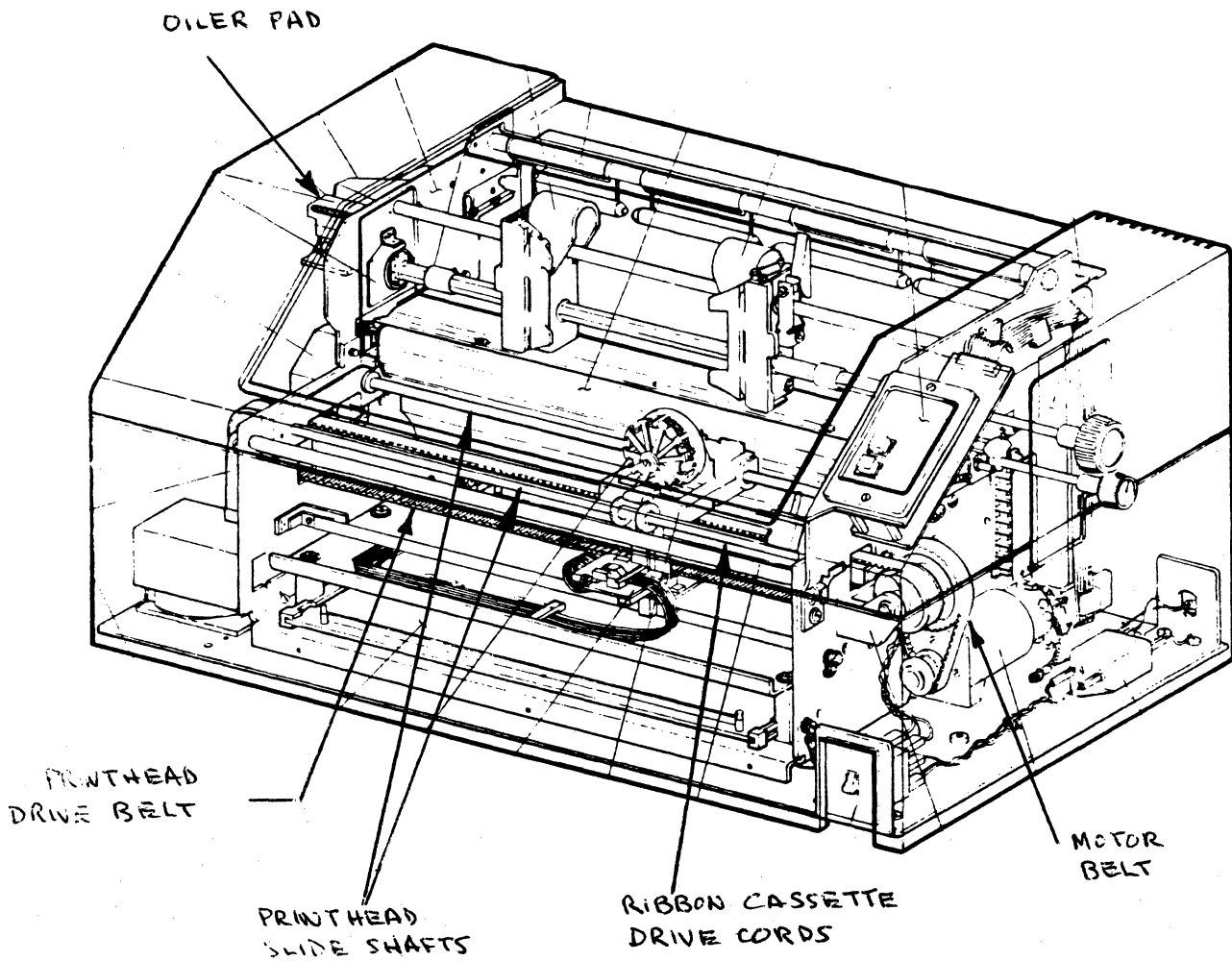

Figure A-1. Printer Check Items

- 2.2) Inspect printhead drive belt and motor belt for fraying. If frayed, replace.
- 2.3) Examine ribbon cassette drive cords and, if frayed, replace (printer field service and reference manual contains procedure).
- 2.4) Clean printhead-slide shaft as follows:
 - a) Using a clean, dry, lint-free cloth, wipe shafts until clean. Move printhead carriage as necessary to access shafts along entire length.

CAUTION

Do not use solvents or cleaning fluids to clean printhead.

2.5) Do test print exercise as follows:

CAUTION

Never run a test print for an extended period of time (over 2 or 3 minutes) because print-pin solenoid may be damaged.

NOTE

During regular operation, format tape loading is required whenever printer is turned on or the 6/8 LPI switch setting is changed. This, however, is not necessary in following test print operations.

- a) Check that paper is loaded properly (procedure 70-2).
- b) With power cord plugged into site power outlet, press ON/OFF switch to turn printer on.

NOTE

To operate printer with the front cover removed, the interlock switch - to the left of the control panel - is pulled up.

- c) Press TEST PRINT switch on printer control panel. Printer prints alternating groups of Bs and spaces across page with single line advances. Use this pattern to check vertical and horizontal alignment of forms.
- d) Press TEST PRINT again to end test print operation.
- e) Change setting of 6/8 LPI switch on vertical transducer board and press TEST PRINT. Check that printout shows new selection of vertical line spacing.

- f) End printout by pressing TEST PRINT again.
- g) Change setting of 10/16.5 CPI switch on vertical transducer board and press TEST PRINT. Check that printer prints 10 or 16.5 characters per inch horizontally (standard versus compressed pitch respectively).
- h) Press TEST PRINT again and return the 6/8 LPI and 10/16.5 CPI switches to their original settings.
- i) Examine test printout for print quality (light or missing dots or improper character width. If any problem exists, refer to table 70-1, DDLT for the impact character printer.

NOTE

At least two full pages of forms would move through tractors in the following step. To prevent this paper loss, press clutch retractor lever during format tape loading.

- j) Verify that format tape is installed correctly in printer (procedure 70-4). Press vertical transducer board LOAD EVFU switch to load form format from tape into printer memory. During the loading, tape passes through reader until two successive form-feed punchings are sensed. Then tape is automatically reread to check loaded data. When tape movement stops, load and check is complete.
 - k) Using clutch retractor lever and vertical forms positioning knob, align paper so printhead is at a top of form.
 - l) Press FORM FEED switch and see if paper advances to next top of form. If it does not, refer to table 70-1.
- 2.6) Upon completion of any corrective maintenance found to be necessary, do the following:
- a) Turn printer power off and unload paper forms from printer.
 - b) Reinstall all cabinet covers (procedure 70-5).
 - c) Reload paper forms in printer (procedure 70-2).

DIAGNOSTIC AND CORRECTIVE MAINTENANCE (70-LPM IMPACT PRINTER)

Maintenance activity for a terminal subsystem falls into three general categories: preventive, diagnostic, and corrective. Preventive maintenance has already been discussed earlier in this section. This portion of the text concentrates on diagnostic and corrective maintenance. Diagnostic maintenance provides an organized means of diagnosing a malfunction and of identifying its source.* Corrective maintenance consists of the procedures for correcting a diagnosed malfunction and of those procedures used to verify that the malfunction has been corrected. This terminal subsystem used the checkout tests of procedure TS6 (Terminal Subsystem Checkout, in the manual) both as a means of verifying that malfunction exists and that a malfunction has been corrected. It uses the diagnostic decision logic tables and the procedures in this section to efficiently diagnose and correct a malfunction.

DIAGNOSTIC TABLES (70-LPM IMPACT PRINTER)

The key for isolating a subsystem malfunction to its probable cause is proper use of the cookbook-type diagnostic tables that follow. These tables, termed diagnostic decision logic tables (DDLTs), or simply decision tables, identify and isolate a malfunction in an equipment to a replaceable module, or where equipment design does not permit this approach, to a replaceable part or component. The tables present test setup and resulting symptom information in a logical, organized manner, and where necessary, they refer to procedures for testing, adjusting, or replacing a suspect component. References to procedures are also made in a sequenced manner so that they refer to the easiest procedure or most likely cause first and progress to the most difficult procedure or least likely cause.

70-LPM IMPACT PRINTER CORRECTIVE MAINTENANCE PROCEDURES — GENERAL

The following pages identify procedures referenced either from table 70-1, DDLT for Impact Printer, or elsewhere within the manual. In addition, other procedures which may serve useful are identified. This impact printer has two companion manuals (95445028 Field Reference, 95445025 Parts Identification Manual) which cover the detailed remove/replace procedures, adjustments, and all parts data identification. Whenever such procedures are identified on the following pages, a reference appears to send the reader to the proper procedural details in the companion field service manual.

* LED Diagnostics are used as a supplement to the decision logic tables. The LEDs consist of six light emitting diodes mounted on the Controller Electronics Printed Circuit Card Assembly located in card location 1PC2. With this installed, the controller electronics isolates and displays on six LED lamps, a binary code for a controller detectable error condition. A summary of the codes and their interpretation is given following the decision logic tables.

TABLE A-2. 70-LPM IMPACT PRINTER (SHEET 1 OF 4)

POWER ON AND EXTERNAL SWITCH CHECKS (EXCLUDING TEST PRINT)										
Entry from CRT DDLTs or malfunction that indicates only printer is at fault. Printer installed properly. Paper and ribbon loaded in printer (procedures 70-2 and 70-3) and printer ON/OFF circuit breaker pressed to ON.										
CONDITIONS	SITUATIONS									
	1	2	3	4	5	6	7	8	9	10
Is ON/OFF circuit breaker lamp lighted?	Y	Y	Y	Y	Y	Y	N	N	-	OTHER
Is fan motor running?	Y	N	Y	Y	Y	Y	N	Y	-	
Load format tape (procedure 70-4). Does it load OK?	Y	-	N	Y	Y	Y	-	-	-	
Press FORM FEED switch on printer. Do forms advance properly?	Y	-	-	N	N	Y	-	Y	-	
Does forms runaway occur (continuous form feeding) after pressing FORM FEED switch? (If yes, stop runaway by turning printer power off.)	-	-	-	N	Y	-	-	-	-	
Press START/STOP switch. Does its lamp light?	Y	-	-	-	-	N	-	Y	-	
Remove printer front cover and move printhead from side to side. Does ribbon advance as printhead is moved?	Y	-	-	-	-	-	-	-	N	
ACTIONS	SEQUENCE									
Go to sheet 2 and perform test print.	X	-	-	-	-	-	-	-	-	-
Ensure front cover is actuating (pressing down) interlock switch, or that interlock switch is pulled up if front cover is removed.	-	-	-	-	-	1	-	-	-	-
Remove all cabinet covers (procedure 70-5).	-	1	2	2	2	3	1	1	2	-
Check internal cables/connections (figure 70-14 and procedure 70-11).	-	2	-	3	3	4	2	-	-	-
See fault isolation checks under Printer Does Not Power On heading in printer manual.* Also check power transformer while doing these checks (see diagrams in printer manual).	-	-	-	-	-	-	3	-	-	-
Replace fan (reference procedure in printer manual).*	-	3	-	-	-	-	-	-	-	-
If paper moved, check to ensure correct punching of channel 1 on format tape. Also check that tape has no more than 176 sprocket holes.	-	-	1	1	1	-	-	-	-	-
Check/replace fuses (procedure 70-10).	-	-	3	4	4	-	-	-	-	-
Check FORM FEED switch for continuity (see diagrams in printer manual).*	-	-	-	5	-	-	-	-	-	-
See fault isolation checks under No Paper Motion In Start Mode heading in printer manual.* Refer to procedure 70-6 if board replacement is necessary.	-	-	-	6	-	-	-	-	-	-
Check START/STOP switch for continuity (see diagrams in printer manual).*	-	-	-	-	-	5	-	-	-	-
See fault isolation checks under Start Lamp Does Not Come On When Start switch is Depressed heading in printer manual.* Refer to procedures 70-10 or 70-6, 70-7, or 70-8 if fuse or board replacement is necessary.	-	-	-	-	-	6	-	-	-	-
See fault isolation checks under Electronic Vertical Format Unit Does Not Load heading in printer manual.* See procedures 70-6 or 70-8 if board replacement is necessary.	-	-	4	-	5	-	-	-	-	-
Check/replace lamp in appropriate switch. See printer manual for diagrams/procedures.*	-	-	-	-	-	2	-	2	-	-
Replace vertical transducer board (procedure 70-8).	-	-	-	-	6	-	-	-	-	-
Replace RS-232 interface board (procedure 70-6).	-	-	-	7	-	-	-	-	-	-
Check/replace ribbon (procedure 70-3).	-	-	-	-	-	-	-	-	1	-
Check/replace ribbon drive cords (printer manual).*	-	-	-	-	-	-	-	-	3	-
Call for assistance.	-	-	5	8	7	7	4	-	4	X
NOTES: * indicates printer Field Service and Reference Manual listed in preface.										

TABLE A-2. 70-LPM IMPACT PRINTER (SHEET 2 OF 4)

TEST PRINT								
ASSUME								
Power on and external switch checks of sheet 1 of this DDLT ran OK.								
CONDITIONS	SITUATIONS							
	1	2	3	4	5	6	7	8
With START/STOP switch extinguished (offline), press TEST PRINT switch. Does printer produce print pattern as shown in figure 70-17?	Y	N	N	N	N	N	N	N
Are forms feeding correctly?	Y	N	N	Y	Y	Y	Y	O
Is printhead movement correct?	Y	N	Y	N	Y	Y	Y	T
Is there any printout?	Y	N	-	-	N	Y	Y	H
Are all portions of all characters printed?	Y	-	-	-	-	N	Y	E
Is each character printed the proper one?	Y	-	-	-	-	-	N	R
ACTIONS	SEQUENCE							
Go to sheet 3 and perform print quality checks.	X	-	-	-	-	-	-	-
Remove all cabinet covers (procedure 70-5) and check seating of PC board connectors.	-	1	1	1	2	2	1	-
Replace needle driver board (procedure 70-7).	-	-	-	-	-	-	3	-
Replace controller/head logic board (procedure 70-6).	-	-	4	-	-	-	4	-
Check TEST PRINT switch for continuity (diagrams in printer manual).*	-	2	-	-	-	-	-	-
Check printhead drive belts and pulleys.	-	-	-	2	-	-	-	-
Lift front cover and check seating of printhead connector.	-	-	-	-	1	1	-	-
Check cables/wires to/from TEST PRINT switch (procedure 70-11).	-	3	-	-	-	-	-	-
Check cabling between needle driver board and printhead (procedure 70-11).	-	4	-	3	3	3	2	-
Replace vertical transducer board (procedure 70-8).	-	-	3	-	-	-	-	-
Do fault isolation checks titled Printer Goes Start But Nothing Happens in printer manual.* If required, replace controller/head logic or power supply board (procedure 70-6).	-	5	-	4	-	-	-	-
Do Format Reader and Code Disk Synchronization Tests in printer manual.*	-	-	2	-	-	-	-	-
Do fault isolation checks titled Printhead Moves, But Does Not Print in printer manual.* If required, replace needle driver board (procedure 70-7) controller/head logic or power supply board (procedure 70-6).	-	-	-	5	4	5	-	-
Replace printhead (procedure 70-13).	-	-	-	-	5	4	-	-
Call for assistance.	-	6	5	6	6	6	5	X
Notes: After completing any repairs, verify printer is operational by pressing TEST PRINT.								
* Field service and reference manual listed in preface.								

TABLE A-2. 70-LPM IMPACT PRINTER (SHEET 3 OF 4)

PRINT QUALITY CHECKS										
ASSUME										
Test print operation per sheet 2 of this DDLT completed and resulting printout available for print quality analysis.										
CONDITIONS	SITUATIONS									
	1	2	3	4	5	6	7	8	9	
Is printing dark enough across entire page?	Y	Y	Y	Y	Y	Y	Y	N		
Are all dots in character of uniform density?	Y	Y	Y	Y	Y	Y	N	-		
Are dots which compose each character evenly spaced from each other horizontally across entire page?	Y	Y	Y	Y	Y	N	-	-	10 11 12	
Are columns of characters uniformly aligned one under the other down entire page?	Y	Y	Y	Y	N	-	-	-		
Is spacing between lines of characters even/proper down entire page?	Y	Y	Y	N	-	-	-	-		
In standard pitch (10 CPI), are 132 character positions (including spaces) printed in each line?	Y	Y	N	-	-	-	-	-		
Does printer respond to 10/16.5 CPI and 6/8 LPI switch settings?	Y	N	-	-	-	-	-	-		
ACTIONS										
SEQUENCE										
Print quality checks OK. Go to sheet 4 and perform remaining printer checks.	X	-	-	-	-	-	-	-	-	
Remove all cabinet covers (procedure 70-5).	-	1	1	2	1	1	3	3	1	
Check that all switches on controller/head logic board are set to off (figure 70-8).	-	2	2	-	-	-	-	-	-	
Check paper tension weights.	-	-	-	1	-	-	-	-	-	
Do Cod Strip to Reader Alignment Tests in printer manual.*	-	-	-	-	2	-	-	-	-	
Check adjustment of pots P4, P6, and P7 on controller/head logic board (see Horizontal Servo System Tests and Adjustments in printer manual).*	-	-	-	-	3	-	-	-	-	
Check adjustment of pot P2 on controller/head logic board (see Horizontal Servo System Tests and Adjustments in printer manual).*	-	-	-	-	4	-	-	-	-	
Adjust forms density control knob.	-	-	-	-	-	-	1	1	-	
Check for worn out ribbon and replace cassette if necessary (procedure 70-3).	-	-	-	-	-	-	2	2	-	
Check adjustment of pots P8 and P10 on controller/head logic board (see Vertical Servo System Tests and Adjustments in printer manual).*	-	-	-	3	-	-	-	-	-	
Do Printhead to Platen Tests in printer manual.*	-	-	-	-	-	2	4	4	-	
Replace printhead (procedure 70-13).	-	-	-	-	-	-	5	5	-	
Do Format Reader and Code Disk Synchronization Tests in printer manual.*	-	3	-	-	-	-	-	-	-	
Replace vertical transducer board (procedure 70-8).	-	4	-	4	-	-	-	-	-	
Call for assistance.	-	5	3	5	5	3	6	6	X	
Notes: After completing any repairs, verify printer is operational by pressing TEST PRINT.										
* Field service and reference manual listed in preface.										

TABLE A-2. 70-LPM IMPACT PRINTER (SHEET 4 OF 4)

PRINTER/CRT INTERFACE CHECKS			
ASSUME			
Power is on at the printer and all printer switch operations (including TEST PRINT) check OK per preceding sheets of this table. Printer input/output cable connected either to keyboard display PERIPHERAL CONNECTOR and keyboard display terminal is operational.			
CONDITIONS	SITUATIONS		
	1	2	3
Do the impact printer test portion of procedure TS6 from the step where the START/STOP switch is pressed to light the switch indicator up to the end of the impact printer test. Assume that the keyboard switches are set per beginning of printer checkout steps and that rear panel TEST/NORMAL switch of display is in TEST position. After these test steps, use keyboard REPEAT and character key to print several print lines (132 characters a line). Does printer perform all checks properly?	Y	N	RMI-10
Caution: Do not allow a printer to continuously print adjacent columns for more than 5 minutes maximum at a time or solenoid will overheat and be damaged.			
ACTIONS	SEQUENCE		
Printer works OK. Return to table TS1.	X	X	-
Check input/output cable at printer and at other end.	-	1	-
Open logic chassis panel (procedure 70-5) and observe for proper printed circuit board seating in the printer logic rack (especially check RS-232 interface board).	-	2	-
Observe for proper connections from printer logic module to input/output connector.	-	3	-
Remove RS-232 interface board (procedure 70-6), and check that all switches/jumpers are properly set for this subsystem (procedure 70-8). Reinstall RS-232 interface board (procedure 70-6).	-	4	-
Replace RS-232 interface board (procedure 70-9) with a new board making sure new board has proper switch/jump settings for this subsystem (procedure 70-9).	-	5	-
Replace common controller board (procedure 70-6).	-	6	-
Replace paper out switch.*	-	7	-
See detailed field service manual and parts manual (see preface) and check/adjust/replace until fault found.*	-	8	-
Call for assistance.	-	9	-
Notes: After completing any repairs, verify printer is operational by pressing TEST PRINT.			
* Field service and reference manual listed in preface.			

PRINTER STATUS/ERROR INDICATORS

These six indicators (see figure 70-1), accessible via the side cover, display a code that informs the operator of printer operating status and/or of a printer error condition. A definition of these codes is provided in the six Printer Status/Error indicators, located under the side cover, display a code that shows:

- If the printer is inoperable and requires maintenance personnel attention.
- When format tape loading is unsuccessful, the cause.
- When neither of the preceding conditions have occurred, the current operating status of the printer.

Table A-3 defines all the codes that the indicators may display.

TABLE A-3. PRINTER STATUS/ERROR INDICATOR CODES

CODE DISPLAYED BY INDICATORS*						SIGNIFICANCE
5	4	3	2	1	0	
0	0	0	0	0	1	Printer requires maintenance personnel attention
0	0	0	0	1	0	Printer requires maintenance personnel attention
0	0	0	0	1	1	START/STOP switch not released
0	0	0	1	0	0	Printer waiting for switch actuation (if an attempt to actuate the START/STOP switch has been made, this means the front cover interlock switch is open)
0	0	0	1	0	1	The format tape loaded is missing channel 1 punchings
0	0	0	1	1	0	The format tape loaded is punched incorrectly
0	0	0	1	1	1	LOAD EVFU switch not released
0	0	1	0	0	0	The format tape loaded is too long (more than 176 lines)
0	0	1	0	0	1	Printer requires maintenance personnel attention
0	0	1	0	1	1	Printer waiting to load data into line buffer
0	0	1	1	0	0	Printer is loading data into line buffer, but printline accumulation is not complete
0	0	1	1	1	0	FORM FEED switch not released
0	0	1	1	1	1	TEST PRINT switch not released
0	1	0	1	0	0	} Printer requires maintenance personnel attention
0	1	0	1	0	1	
0	1	0	1	1	0	
0	1	0	1	1	1	
0	1	1	1	0	0	
0	1	1	1	0	1	
0	1	1	1	1	0	

* Key:
 1 = indicator lit
 0 = indicator not lit

For the 70-LPM Impact Printer, information provided in this hardware maintenance manual, plus detailed data in the companion field service and parts manuals, allows troubleshooting down to a very detailed level. This is in keeping with the policy of being able to perform detailed troubleshooting and repair at the customer site for medium and large printer equipments. This philosophy differs with the modular repair level approach used for small, lightweight printers such as the Nonimpact Printer.

Generally, it is at the discretion of the customer engineer making a service call to decide at which level adjustments or remove and replace procedures should be done for the best overall results at any particular site. This decision must take into consideration the availability of possible required spare parts, and availability/type of test equipment and tools which are required for different level adjustment/replace-ment procedures.

The two companion manuals support maintenance down to the level of PC board components and complex adjustments which require special tools/talents. The maintenance philosophy of this hardware maintenance manual is to limit the detailed level of maintenance for a printer when used as a peripheral device with a display terminal. On the site, this means maintaining certain areas of the printer at a higher level than may be possible by using all information available in the manuals. Specifically, these limitations are defined as follows:

- o On the power supply circuit board, replace fuses only (procedure 70-10), otherwise replace the whole board (procedure 70-6).
- o Repair any of the three logic boards in the logic chassis only by replacing them at board level (procedure 70-6 and 70-7) except for on-board fuses (procedure 70-10).

Procedure 70-1 — Powering On Printer

Apply power to printer as follows:

- 1) Check ac power cord and I/O cable to ensure printer is ready for operation.
- 2) Ensure paper forms are properly installed and aligned in printer (procedure 70-2).
- 3) Ensure ribbon cassette is installed in printer (procedure 70-3).
- 4) Press ON/OFF circuit breaker on front of printer to ON. ON/OFF circuit breaker illuminates.
- 5) Lift side cover (figure 70-1) from printer, and set the 6/8 LPI switch to 6 LPI.

NOTE

At least two full pages of forms will move through tractors in the following step. To prevent this paper loss, press clutch retractor lever (figure 70-1) during loading.

- 6) Check that format tape is properly installed (procedure CHP4) and press LOAD EVFU switch to load format from tape into printer memory.
- 7) If the 6/8 LPI switch was originally at 8 LPI, return the switch to that position.
- 8) Using clutch retractor lever and vertical forms positioning knob (figure 70-1), align paper so printhead is at a top of form.
- 9) If front cover is in place, check that it is seated securely; if front cover is removed, pull interlock switch up.
- 10) Press START/STOP switch on printer control panel. START/STOP switch should illuminate. If not, redo step 9 and press START/STOP again.

When printer power is to be turned off, press ON/OFF circuit breaker to OFF.

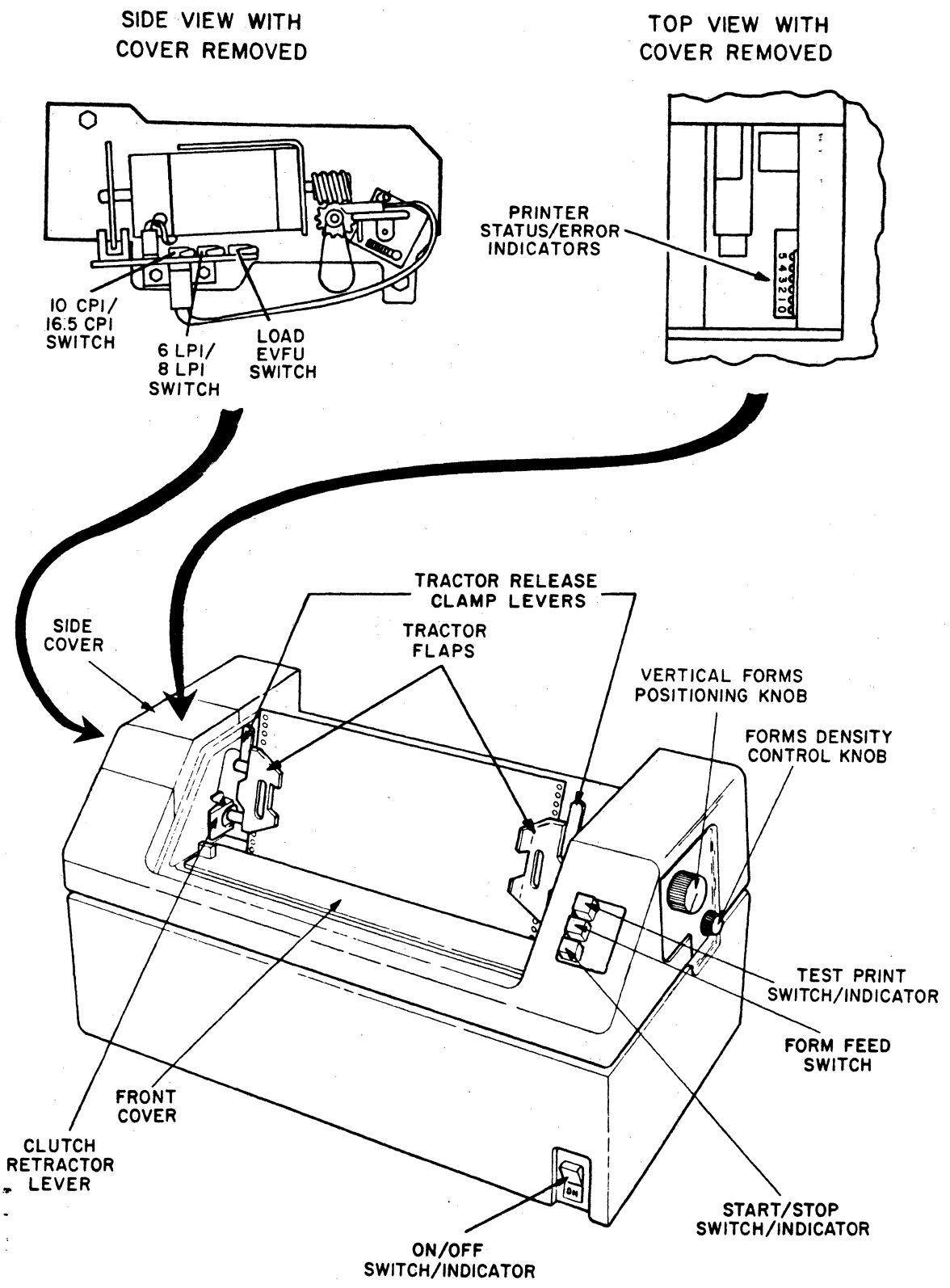

Figure 70-1. Impact Printer Controls and Indicators

02855

Procedure 70-2 — Installing/Aligning Paper Forms

To install/align paper forms in printer, perform the following:

- 1) Turn printer power off and lift front cover from printer.
- 2) Place stack of fan folded forms on flat surface behind printer (figure 70-2).
- 3) Insert top form sheet in rear forms slot and under paper tension weights. Paper tension weights can be raised and locked in up position during forms loading. Feed forms into slot from rear until leading edge of forms is visible at front of printer. If forms are multiple-part forms, it may be necessary to increase the gap between platen and printhead by turning forms density control knob (figure 70-1) fully clockwise so forms pass readily through printer.
- 4) Go to front of printer and pull forms until approximately one full form sheet has passed by printhead.
- 5) Open left tractor flap (figure 70-1) and position paper form feed holes on drive pins of tractor. Close tractor slide flap.
- 6) Replace front cover and use column guide on it as reference for setting forms margins.
- 7) Pull left tractor clamp up and slide left tractor to proper position for left margin. Reclamp tractor assembly in place by pushing tractor clamp back.

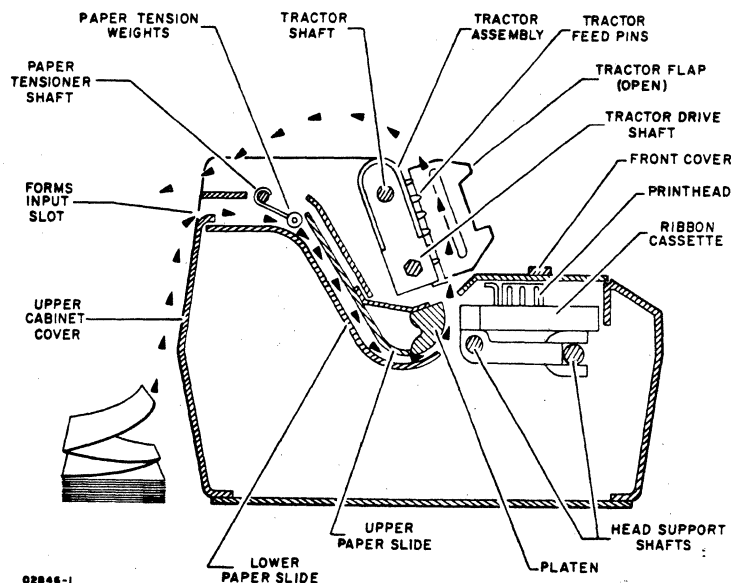

Figure 70-2. Paper Forms Installation

- 8) Open right tractor flap and release its tractor clamp. Position right tractor so tractor feed pins are seen through form feed holes.
- 9) Keep form even and position it on the right tractor feed pins. Verify that form is not slanted horizontally and close tractor flap.
- 10) Slide right tractor to right until form is taut. Push tractor clamp back to clamp tractor in place.
- 11) Turn printer power on and load format tape into printer memory (procedure 70-1).
- 12) Manually align the first print line position of a following form with printhead line finder (figure 70-3), so that printing will occur at the top of that form. This is done by pressing the clutch retractor lever and turning vertical forms positioning knob.
- 13) Reset forms density control knob if it was moved during forms installation. Also lower the necessary paper tension weights. For single-part forms, use only the two center weights. Swing the outer two weights up, away from forms. For multiple-part forms, all four weights are normally used. For narrow forms, lift up any weight not covering the form with at least half its width. If forms tear at feed holes, weights should be lifted until tearing is eliminated. If tearing continues, readjust forms density control knob.

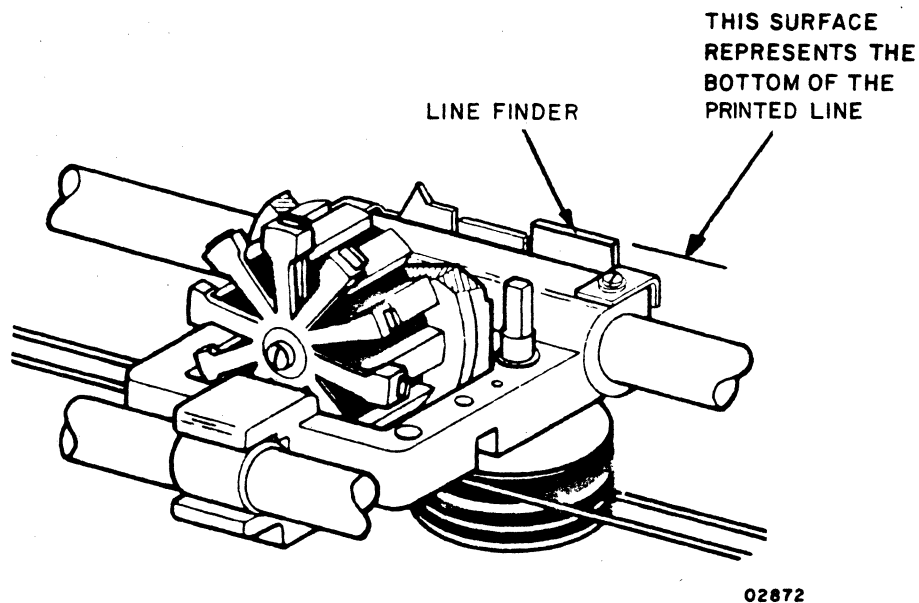

Figure 70-3. Printhead Line Finder

Procedure 70-3 — Replacing Ribbon Cassette

Replace ribbon cassette as follows:

- 1) Turn printer power off and lift front cover from printer.
- 2) Place finger tips under cassette locking tab and pull it up until a slight click is heard indicating that cassette has disengaged from head support and pulley assembly (figure 70-4).
- 3) Remove ribbon cassette by lifting it up off of printhead.
- 4) Remove new ribbon cassette from wrappings and assure that cassette locking tab is in the up (disengaged) position.
- 5) Place new ribbon cassette over printhead so that drive spline on bottom of cassette engages the cassette drive shaft. The ribbon advance knob on top of cassette may be turned counterclockwise slightly to aid in engaging the spline and drive shaft.
- 6) While applying slight pressure to top of cassette, press cassette locking tab down until a slight click is heard. Cassette should now be locked in place.

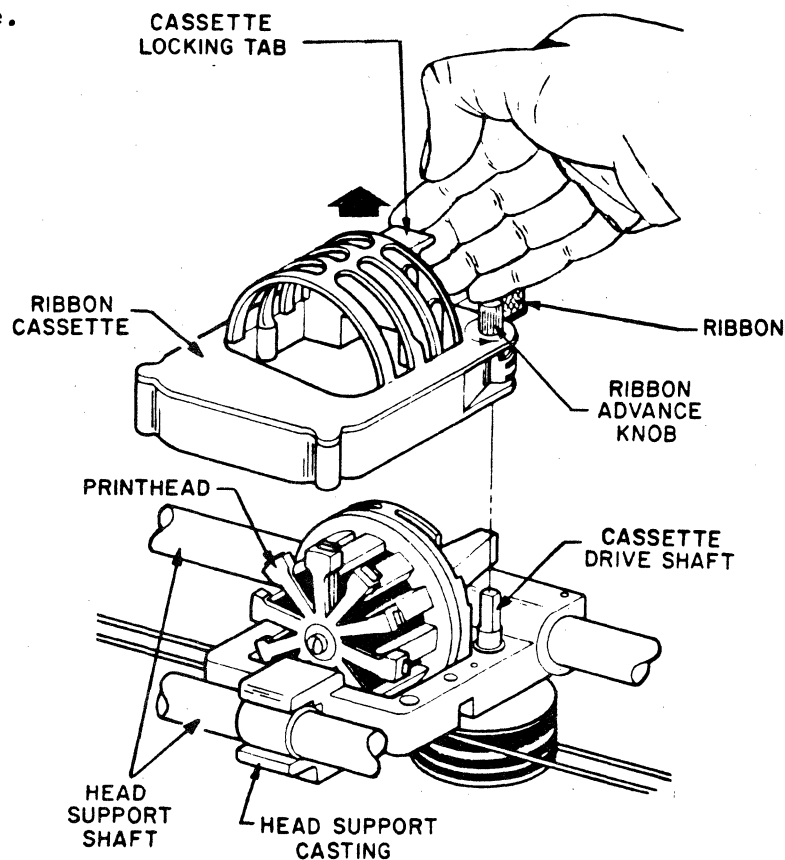

Figure 70-4. Ribbon Cassette Replacement

- 7) To ensure proper seating, grasp cassette by both sides and lift up using moderate pressure. If cassette lifts off printhead, it was not seated properly and steps 4 through 7 must be repeated.
- 8) Replace front cover and make sure it is seated securely, thereby enabling interlock switch.

Procedure 70-4 — Installing/Loading Format Tape

To install/load format tape, refer to figure 70-5 and perform following:

NOTE

Unless format tape is loaded, printer can only perform single-line form advances.

- 1) Turn printer power off and lift side cover from printer.
- 2) Lift brush block away from format tape drive sprocket by pulling brush block retraction lever back, toward front of printer, till lever detent holds block away from drive sprocket.
- 3) Ensure tape is correct for the 6/8 LPI selection and is punched to correspond with forms length (see format tape punching instructions in appendix B).
- 4) Place format tape over teeth on drive sprocket, and then push brush block retraction lever forward toward rear of printer, until brush block holds format tape in place on drive sprocket. Assure that tape is installed with smaller drive holes toward inside (center of printer); this places channel 1 (form feed channel) in the proper position on drive sprocket.
- 5) Push the 6/8 LPI switch to 6 LPI.
- 6) Turn printer power on.

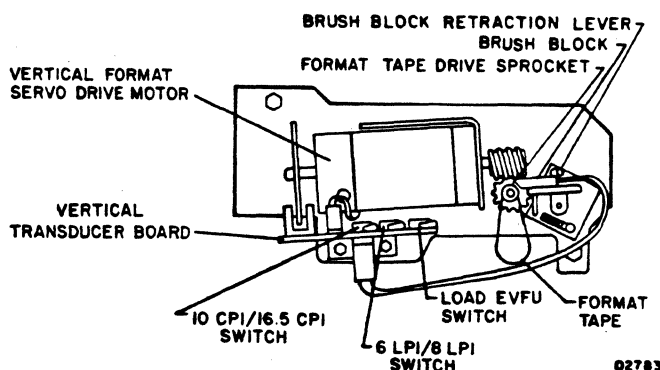

Figure 70-5. Format Tape Installation

NOTE

At least two full pages of forms will move through tractors in the following step. To prevent this paper loss, press clutch retractor lever (figure 70-1) during loading.

- 7) Press LOAD EVFU switch. During loading, tape passes through reader until two successive form-feed punchings are sensed. Tape is then automatically reread to check loaded data. When tape movement stops, load and check is complete.
- 8) If printing is to be at 8 lines per inch (8 lines per 25.4 mm), change setting of the 6/8 LPI switch to 8 LPI.
- 9) Using clutch retractor lever and vertical forms positioning knob, align paper so printhead is at a top of form.

NOTE

Steps 5, 7, and 8 must be repeated each time printer is turned on. If a change in forms length or 6/8 LPI reselection is made, a different format tape must be installed and all the preceding steps repeated.

Procedure 70-5 — Removing/Installing Cabinet Covers

Refer to figure 70-6 and remove appropriate covers as follows:

Front Cover

Removal of front cover provides access for forms loading and changing ribbon cassette and printhead. To remove front cover, grasp the two lifting tabs on either side of cover and lift cover off upper cabinet.

When installing front cover, the beveled edge must be toward rear of printer, facing down. Check that cover corner guides are engaged in upper cabinet and press cover down.

NOTE

The interlock switch under front cover will not close if cover is not properly seated.

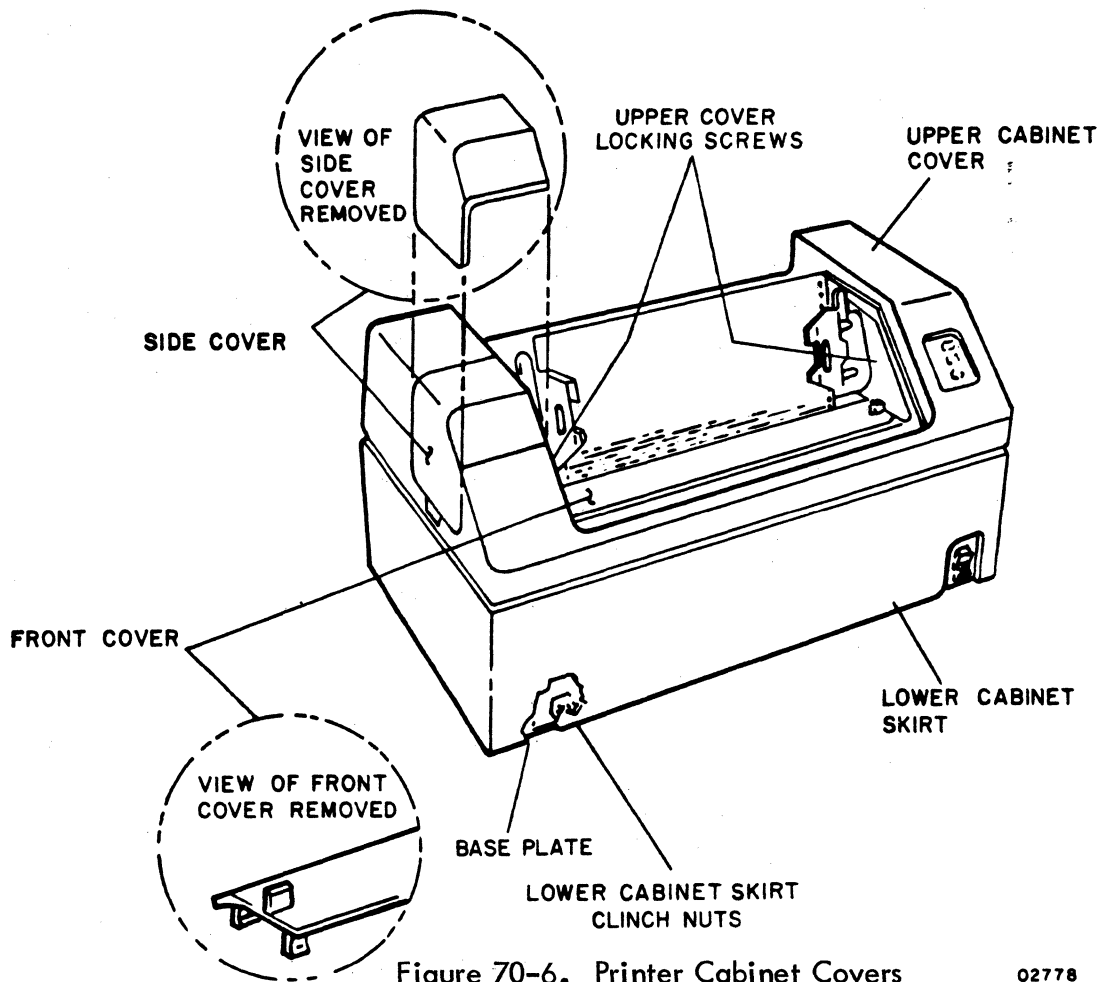

Figure 70-6. Printer Cabinet Covers

02778

Side Cover

Removal of side cover provides access to format tape, 6/8 LPI switch, 10/16.5 CPI switch, and LOAD EVFU switch. To remove side cover, place finger tips in the depression in left side of upper cabinet and lift side cover from cabinet.

Upper Cabinet Cover

Removal of upper cabinet cover provides access to control panel wiring, format reader, vertical servo motor, and printhead slide shafts.

To remove cover, turn two locking screws (figure 70-6) clockwise until they clear the cover. Pull vertical forms positioning knob off its shaft and lift cabinet cover from lower cabinet skirt.

When installing cover, turn locking screws fully counterclockwise.

Lower Cabinet Skirt

Removal of lower cabinet skirt provides full access to printer chassis and must be removed to access most of the PC boards. The lower cabinet skirt cannot be removed without first removing the upper cabinet cover.

To remove skirt, completely loosen four screws (figure 70-6) and lift skirt and screws from base plate.

NOTE

The screws retaining lower cabinet skirt are not captive within skirt and may fall out if skirt is tipped or turned over.

Procedure 70-6 — Replacing Power Supply, Controller/Head Logic Board and RS-232 Interface Board

To replace either the power supply or controller/head logic pc board, perform following:

- 1) Turn printer power off and disconnect ac power cord.
- 2) Locate controller/head logic, power supply and RS-232 interface board 1A04 in printer chassis (figure 70-7).
- 3) Release latch at each side of RS-232 interface board and swing it down first from printer chassis. Next, if controller/head logic board or power supply board needs to be replaced, swing down in the same manner.
- 4) Disconnect all connectors from board being replaced and tag connectors for later reconnection.
- 5) Loosen four screws holding board to chassis hinge bracket and remove board.
- 6) Place new board on chassis hinge bracket and tighten four screws.
- 7) If board(s) contain switches and/or jumpers, check settings/placements per terminal subsystem requirements.
- 8) Reconnect board connectors.
- 9) If controller/head logic board is being replaced, do as follows:
 - a) Check that all eight selection switches on board are set to the off position (figure 70-9).
 - b) Perform horizontal and vertical servo system electrical adjustments per printer field service and reference manual.

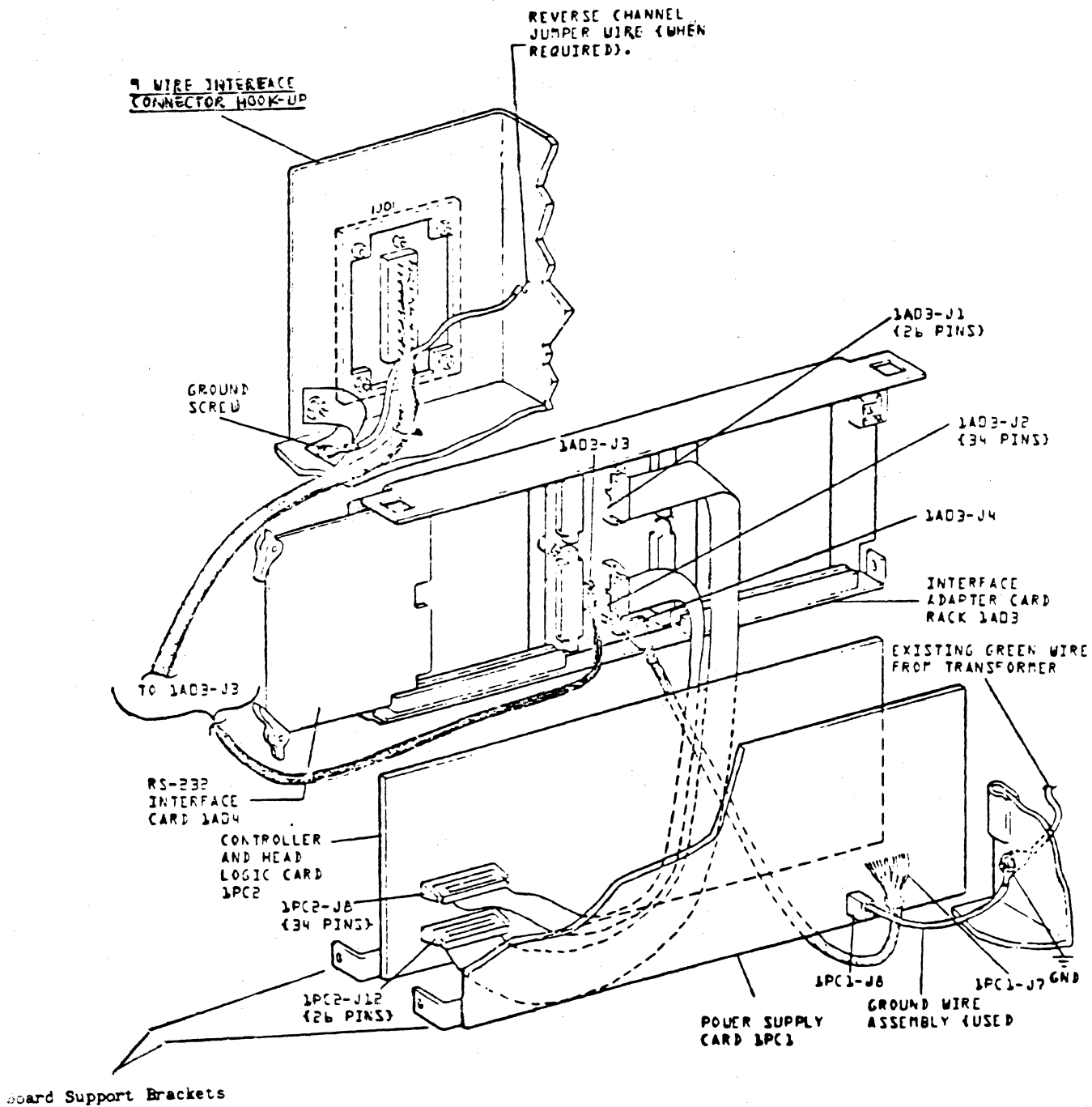

Figure 70-7. RS-232 Interface Card and Rack

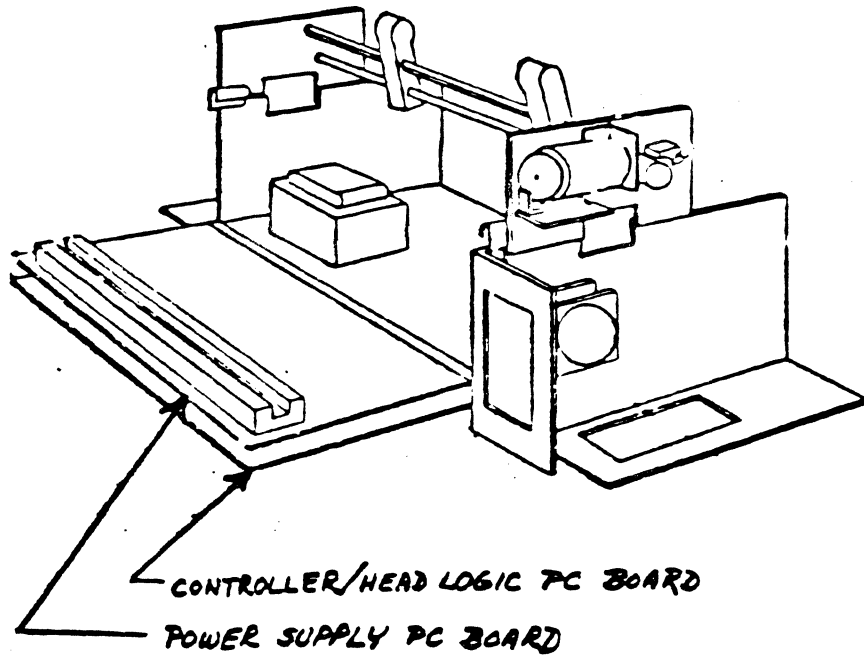

Figure 70-8. Controller/Head Logic and Power Supply Boards

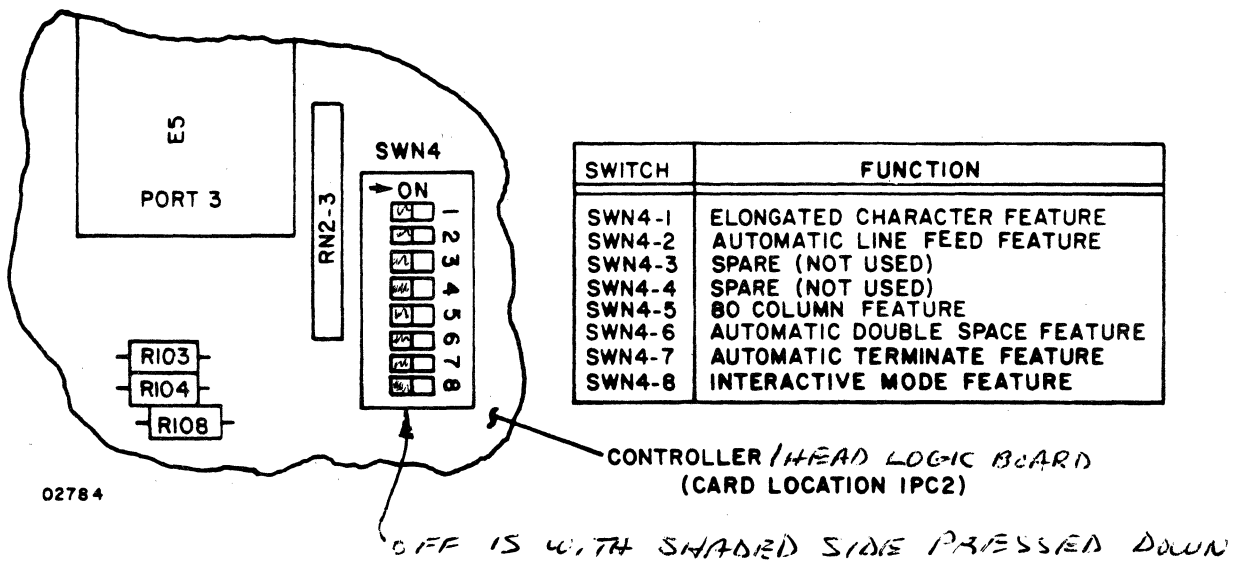

Figure 70-9. Controller/Head Logic Board Switch Settings

- 10) If power supply board is being replaced, do as follows:
 - a) Refer to figure 70-10 and verify all its fuses are in place.
 - b) Perform power supply board electrical adjustments per printer field service and reference manual.
- 11) Swing board(s) up into chassis and latch.

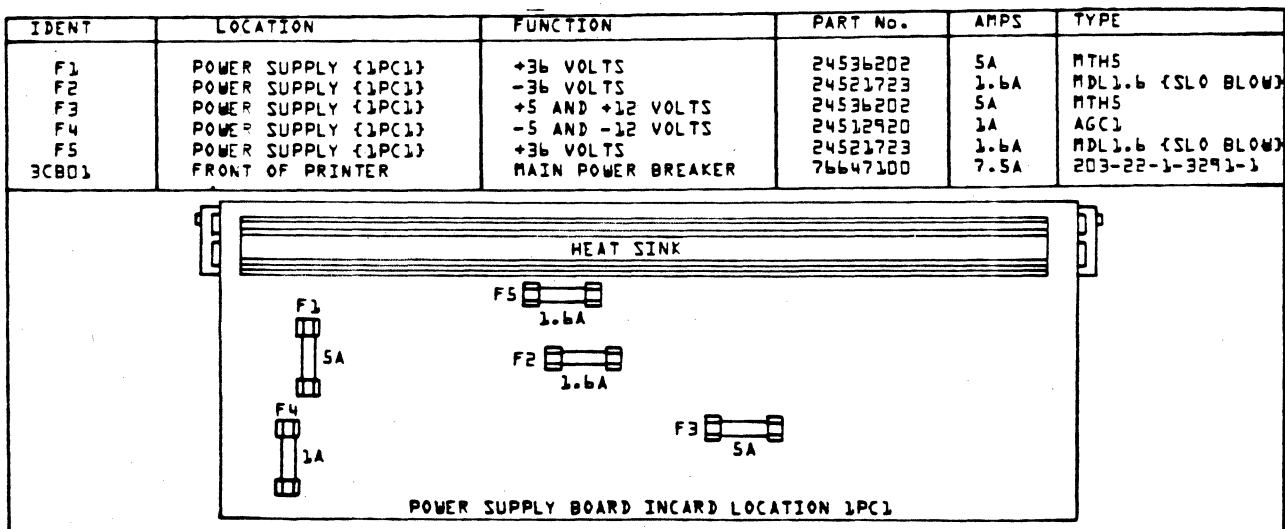

Figure 70-10. Fuses on Power Supply Board

Procedure 70-7 — Replacing Needle Driver Board

To replace needle driver PC board (figure 70-11), perform the following:

- 1) Turn printer power off and disconnect ac power cord.
- 2) From front of printer, grasp front of needle driver board, lift it slightly to clear front board retainers, and partially withdraw it from chassis.
- 3) Disconnect board connectors and tag them for reconnection.
- 4) Slide new board part way into chassis and reconnect board connectors.

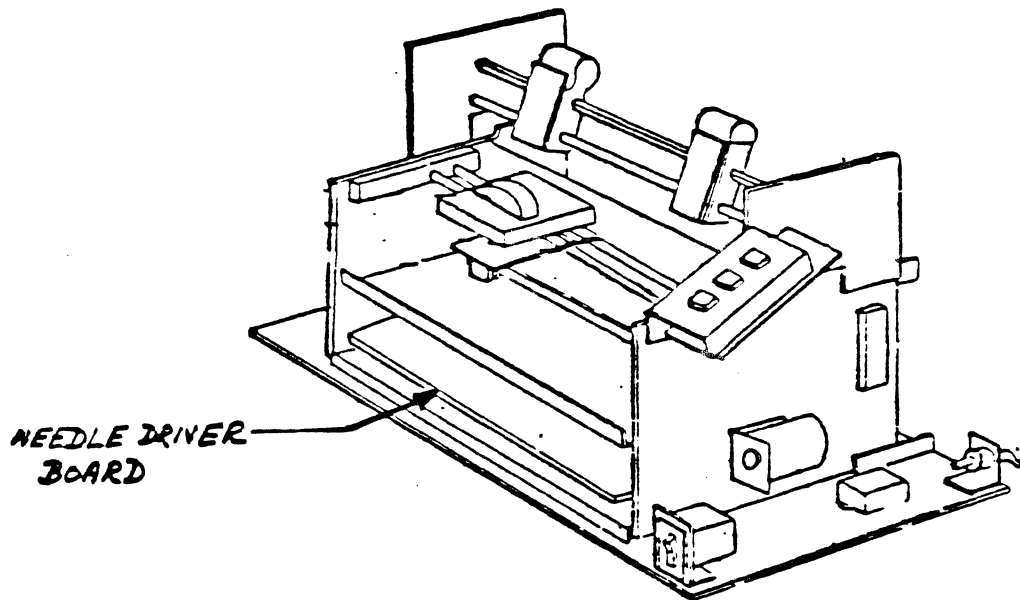

Figure 70-11. Needle Driver Board

- 5) Perform needle driver board electrical adjustment per printer field service and reference manual.
- 6) Slide board back into chassis until board is held by front retainers.

Procedure 70-8 — Replacing Vertical Transducer Board

To replace vertical transducer PC board, refer to figure 70-12 and perform the following:

- 1) Turn printer power off and disconnect ac power cord.
- 2) Remove two screws and nuts holding vertical transducer board mounting bracket to chassis.
- 3) Move board and bracket slightly away from chassis and disconnect three connectors from board.
- 4) Withdraw board and bracket free of chassis, being careful not to damage code disk.
- 5) Remove two screws and nuts fastening board to bracket.
- 6) Fasten new board to bracket with screws and nuts removed in step 5.

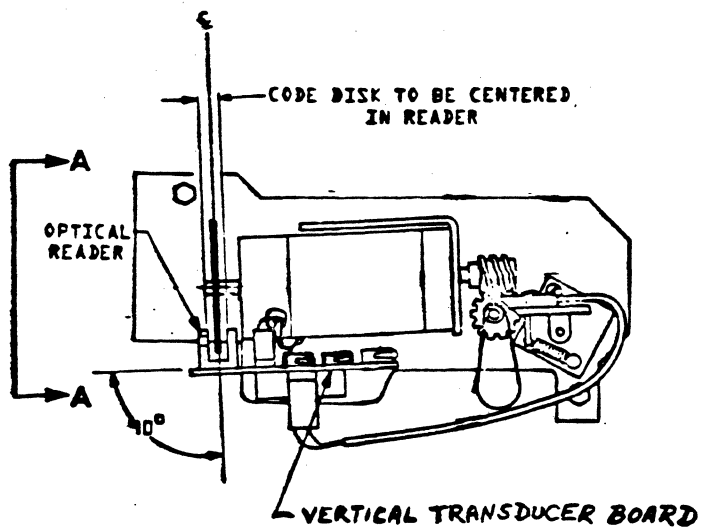
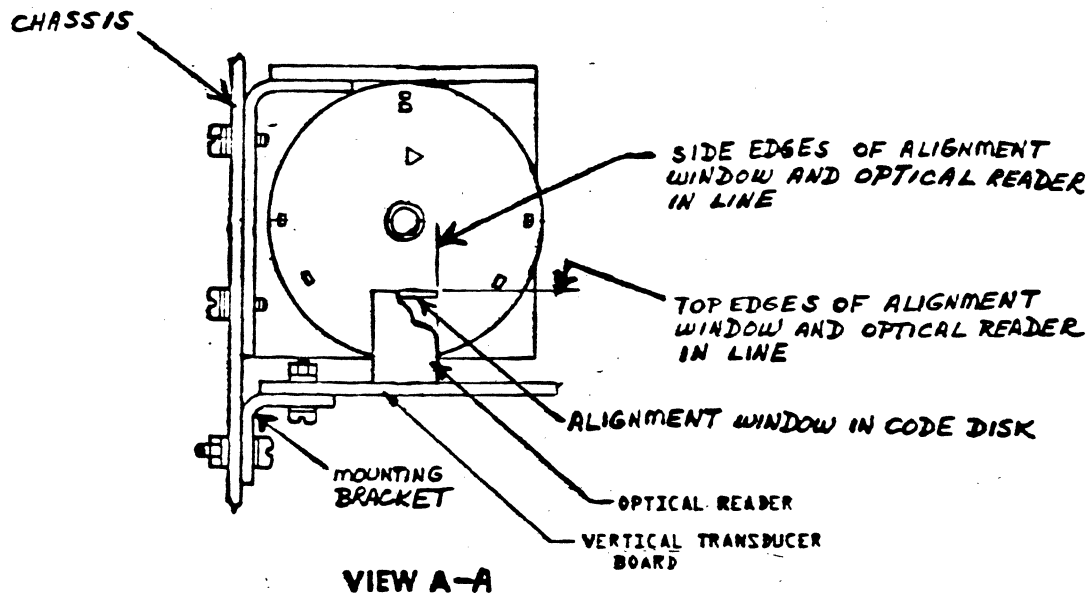

Figure 70-12. Vertical Transducer Board Installation

- 7) Carefully move board and bracket near chassis and attach board connectors.
- 8) Position board and bracket so code disk is between slot of board optical reader. Loosely attach bracket to chassis with screws and nuts.
- 9) Turn code disk until its alignment window is at bottom.
- 10) Adjust position of board and bracket until optical reader is aligned with code disk as shown in figure 70-12. Tighten bracket to chassis.
- 11) Set vertical transducer board 10 CPI/16.5 CPI and 6 LPI/8 LPI switches to desired operating positions:
 - a) With 10 CPI/16.5 CPI switch in 10 CPI position, printer prints standard 132-character print line of 10 characters per inch (10 characters per 25.4 mm). With switch in 16.5 CPI position, printer prints a compressed-pitch line of 16.5 print characters per inch (16.5 characters per 25.4 mm); this permits 217 characters to be printed across a full print line.
 - b) With 6 LPI/8 LPI switch in 6 LPI position, the printer prints 6 lines per inch (6 lines per 25.4 mm) vertically, and with switch in the 8 LPI position, it prints 8 lines per inch (8 lines per 25.4 mm) vertically.

Procedure 70-9 — Checking/Setting Internal Switches and Jumpers

Check/set internal switches and jumpers for the impact printer as follows:

- 1) Open rear logic chassis panel (procedure 70-6).
- 2) Swing RS-232 Interface Board and adapter chassis down to a horizontal position, per directions given in procedure 70-6, step 3.
- 3) Verify that all switches and jumpers (figure 70-13) conform to interface configuration required for correct operation with keyboard display logic (refer to impact printer installation procedures in associated Installation Instruction Manual).
- 4) Return RS-232 Interface Board and adapter chassis to original position.

Procedure 70-10 — Checking/Replacing Fuses

All printer fuses are on the power supply board. To check/replace fuses, do the following:

- 1) Turn printer power off and disconnect ac power cord.
- 2) Lower controller/head logic and power supply boards from printer chassis per steps 2 and 3 of procedure 7016.
- 3) Observe fuses (figure 70-14), and replace any that are burned out.

IDENT	LOCATION	FUNCTION	PART No.	AMPS	TYPE
F1	POWER SUPPLY {1PC1}	+36 VOLTS	24536202	5A	MTH5
F2	POWER SUPPLY {1PC1}	-36 VOLTS	24521723	1.6A	MDL1.6 {SLO BLOW}
F3	POWER SUPPLY {1PC1}	+5 AND +12 VOLTS	24536202	5A	MTH5
F4	POWER SUPPLY {1PC1}	-5 AND -12 VOLTS	24512920	1A	AGC1
F5	POWER SUPPLY {1PC1}	+36 VOLTS	24521723	1.6A	MDL1.6 {SLO BLOW}
3CB01	FRONT OF PRINTER	MAIN POWER BREAKER	76647100	7.5A	203-22-1-3291-1

Figure 70-14. Fuses on Power Supply Board

Procedure 70-11 — Checking Internal Cables

Check internal cables of printer as follows:

- 1) Turn printer power off and disconnect ac power cord.
- 2) Visually inspect internal cables and cable connectors for signs of damage. If loose connectors are found, reconnect and check printer operation before proceeding with the remainder of this procedure.

- 3) Remove connectors at both ends of suspect cable and inspect connector pins (of cable or board where cable attaches) for damage. If damaged pins are found that cannot be repaired, replace cable or PC board as appropriate.
- 4) If damaged connector pins are not found, cable can be further checked by using ohmmeter to check cable-wire continuity. Use diagram in printer field service and reference manual to check cables in this manner.
- 5) If open wire(s) are found, repair if possible or replace cable (procedure 70-12).

Procedure 70-12 — Replacing Internal Cables

Replace a cable within a printer as follows:

- 1) Turn printer power off and disconnect ac power cord.
- 2) Refer to internal cabling diagram (figure 70-15) for cabling interconnections.
- 3) Note connector location and pin orientation before removing cable if necessary, mark or tag connectors to ensure proper reconnection.
- 4) If cable ties must be removed, note their location.
- 5) Install new cable in printer, assuring that cable is properly routed and connected to proper board connectors.
- 6) Install any cable ties that were removed during cable removal.

Procedure 70-13 — Replacing Printhead

Replace printhead as follows:

- 1) Turn printer power off and disconnect ac power cord.
- 2) Lift front cover from printer.
- 3) Remove ribbon cassette from printhead (procedure 70-3).
- 4) Reach under printhead support casting and disconnect printhead harness from flat cable (figure 70-16).

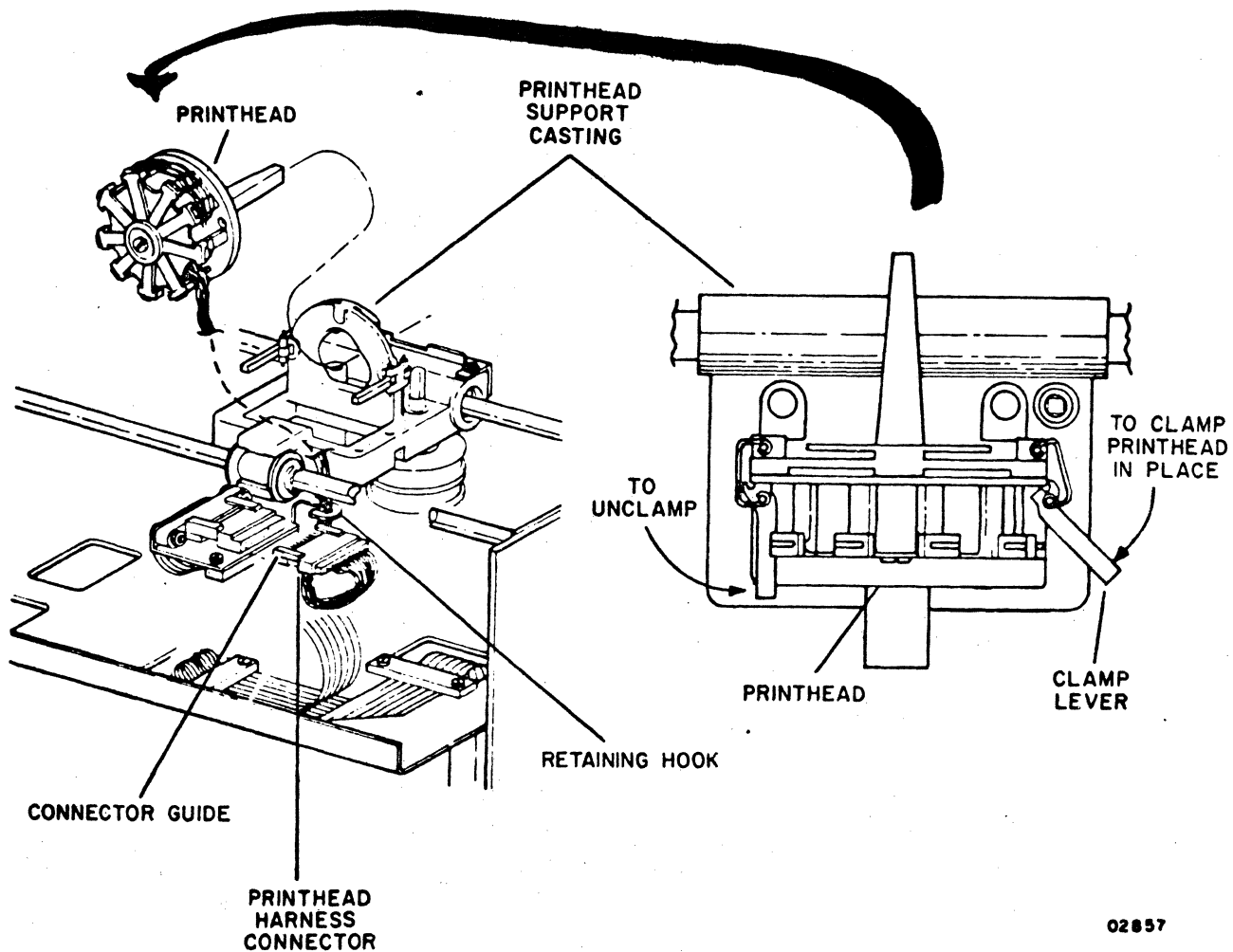

Figure 70-16. Printhead Replacement

- 5) Unclamp printhead from support casting by grasping both right and left hand clamping levers and swinging them out toward side of printer cabinet until printhead is released.
- 6) Remove printhead harness from retaining hook under support casting.
- 7) Slide printhead toward front of printer until printhead is free of support casting.
- 8) Place new printhead with its side holes on support casting guide pins, and slide printhead back against casting.
- 9) Hold printhead against casting with one hand and secure printhead with the two clamping levers. Ensure that ends of clamp levers are on corners of printhead before clamping.

CAUTION

Be careful not to crimp printhead harness wires in next step.

- 10) Route printhead harness as shown in figure 70-16 and connect harness connector to flat cable connector. Ensure that printhead harness connector guides face up when making this connection; also ensure that printhead harness passes behind retaining hook.
- 11) Grasp printhead support casting and slide it back and forth to ensure that printhead harness does not rub on front support shaft or hit on side of printhead structure. Adjust harness in retaining hook if necessary.
- 12) Replace ribbon cassette on printhead (procedure 70-3).

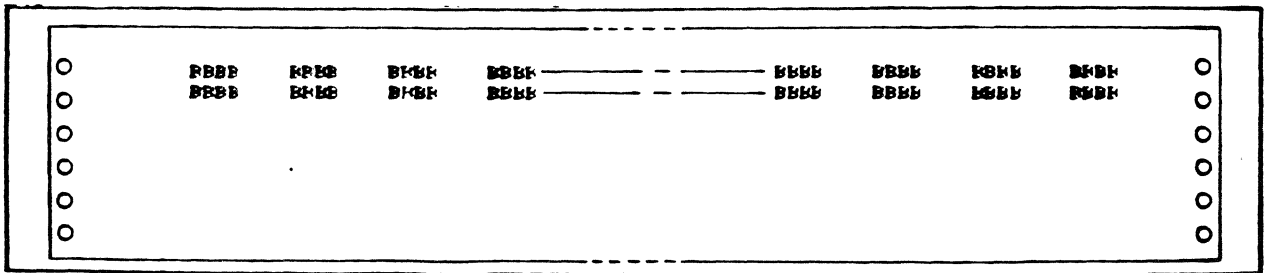
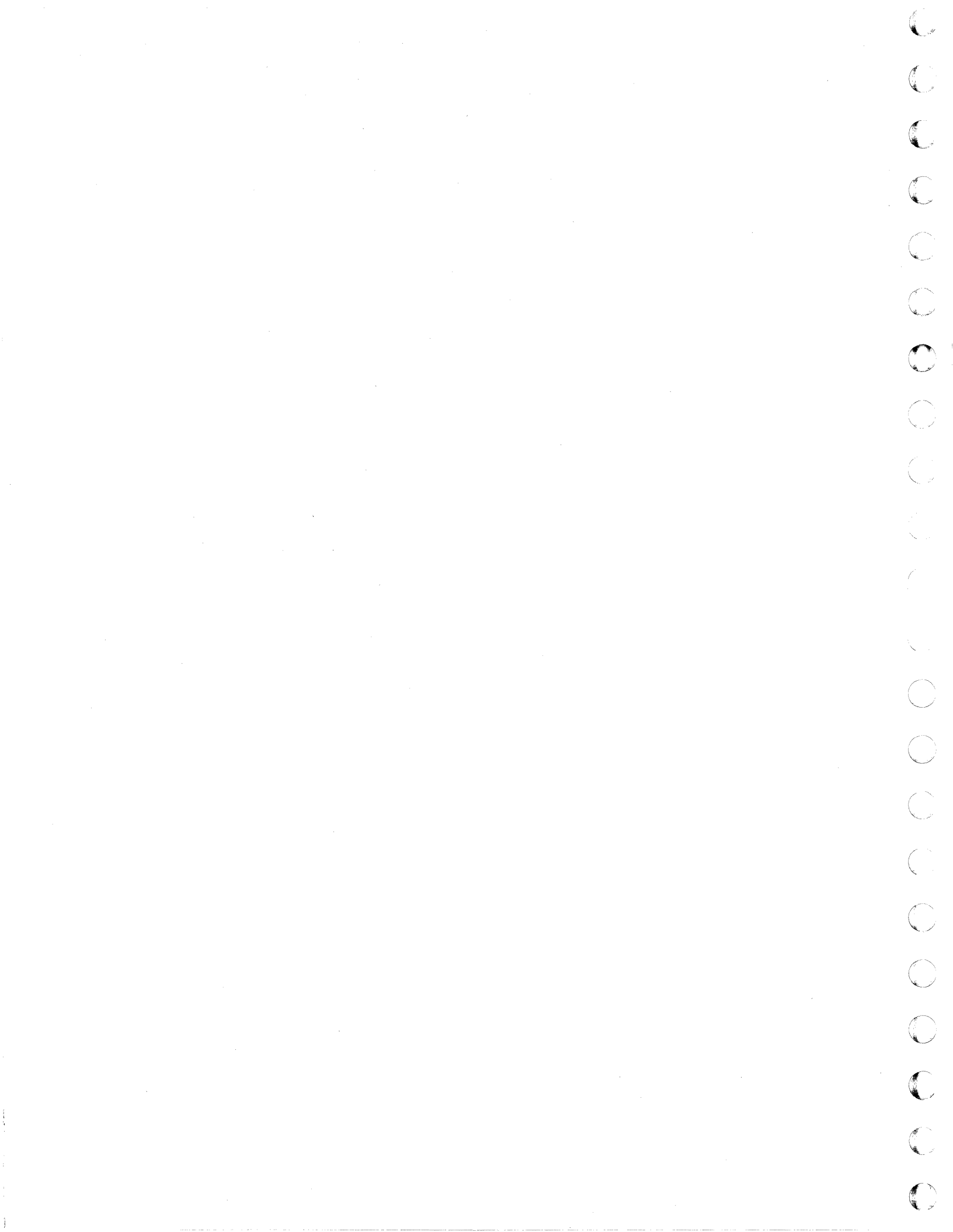

Figure 70-17. Test Print Sample



This appendix describes the forms, ribbon, printhead, and format tape that is used in the impact character printer. Also included, are instructions for punching format tape.

NOTE

For additional forms, ribbon, printheads, or format tape, contact the nearest Control Data Products Representative.

FORMS

The printer will handle standard continuous-fan folded forms paper with feed holes on each edge, with or without marginal perforations. The forms may be from 4 to 16.75 in (101.6 to 425 mm) in width including margins, and 3.5 to 17 in (88.9 to 431.8 mm) long from fold to fold. When using the output paper basket, the forms length is limited to 12 in (304.8 mm) from fold to fold.

The forms must have sprocket holes punched along both margins 0.25 ± 0.03 in (6.35 ± 0.76 mm) from the paper edge to the hole center lines. The distance between hole centerlines must be 0.50 ± 0.005 in (12.7 ± 0.13 mm) nonaccumulative, and the diameter of the holes should be 0.156 ± 0.010 in (3.96 ± 0.25 mm). Multiple-part forms must be suitably fastened with nonmetallic fasteners. The following list specifies the recommended forms in terms of parts and weights.

Parts	White Sulphite Bond Paper	Carbon Paper
1	15 pound continuous bond (56 g/m ²)	
1	24 pound continuous bond (90 g/m ²)	
2 and 3	12 pound continuous bond (45 g/m ²)	8 pound (14 g/m ²)
2 and 3	15 pound continuous bond (56 g/m ²)	8 pound (19 g/m ²)
4 and 5	12 pound continuous bond (45 g/m ²)	6 pound (14 g/m ²)

RIBBON

The printer ribbon consists of a disposable ribbon cassette (CDC part number 44671690).

PRINTHEAD

The operator-replacable printhead (CDC part number 44671738) on the printer is modular and when replacement becomes necessary, the worn-out printhead is disposed of.

FORMAT TAPE

The printer format tape (CDC part number 95414500) is 1 in (25.4 mm) wide with sprocket holes on 0.1 in (2.54 mm) centers. Before use, format tape channel 1 must be punched to correspond with the top-of-form (form feed) position of the length forms in use and channel 2 punched at the desired vertical tab.

PUNCHING FORMAT TAPE

The following procedure describes punching and splicing format tape, making it ready for installation in printer. In addition to format tape, this requires a format tape punch (CDC part number 76657900) and adhesive format tape splice (CDC part number 76628200).

- 1) Raise splicer arm of punch out of way (figure B-1).
- 2) Slide punch head to rear of punch.
- 3) Raise tension arms and place format tape on punch as shown in figure B-1. Then lower tension arms to hold tape in place.
- 4) Slide punch head to the channel 1 position and press punch head down. This punching is the top-of-forms (form feed) hole.
- 5) If vertical tab is also desired at the top-of-forms position, slide punch head to channel 2, and press punch head.

NOTE

If a vertical tab hole is not punched in channel 2, printer receipt of a vertical tab code will cause a forms runaway.

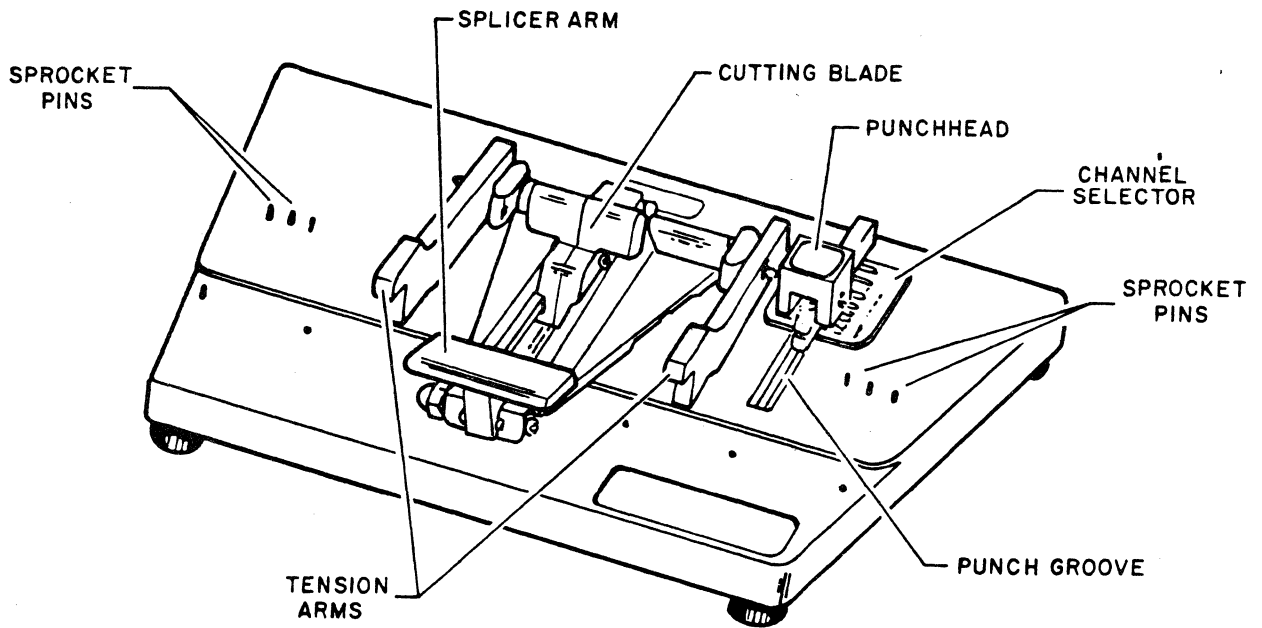
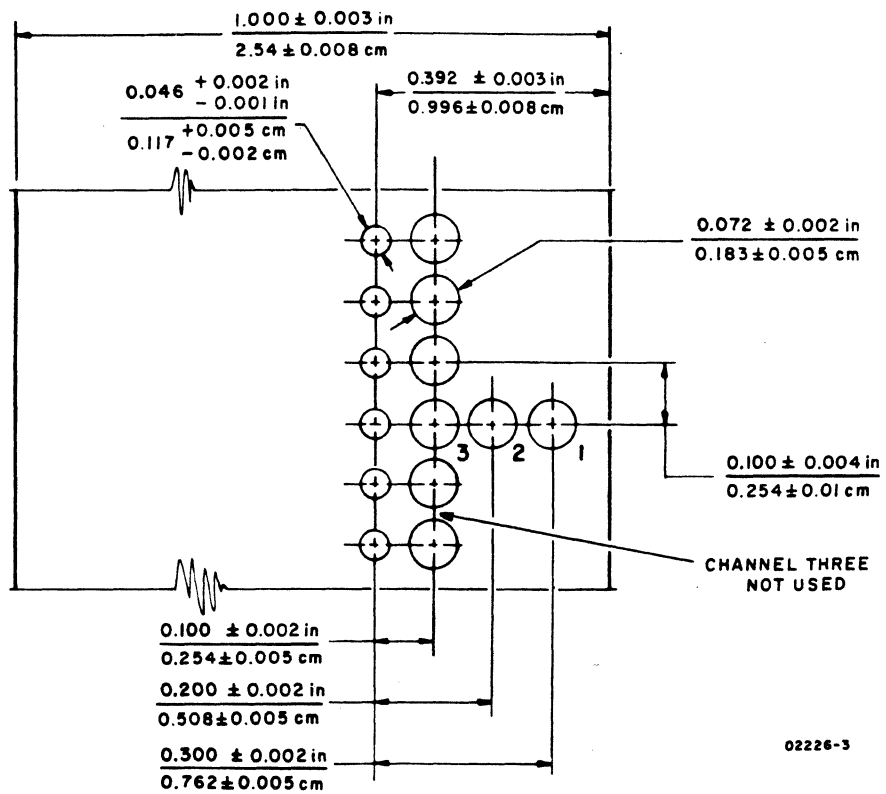

02782-1

Figure B-1. Punching Format Tape

- 6) If vertical tab is to be elsewhere than at top of forms, lift tension arms and do the following:
 - a) Determine how many print lines are between the top-of-forms position and the vertical tab position on form. Depending on the 6/8 LPI selection to be used, there are either 6 or 8 print lines per inch (25.4 mm) on form.
 - b) Each sprocket hole in tape equals one print line. Count the sprocket holes from the top-of-forms hole in tape to the vertical tab position and mark the location with a pencil.
 - c) Reposition format tape so that pencil mark is aligned with punch head. Lower tension arms.
 - d) Slide punch head to channel 2 and press punch head.
- 7) Determine what length format tape must be:
 - a) Multiply form length in inches by the 6/8 LPI selection to be used. The result is the number of tape sprocket holes that equate to a form. For example:

$$\begin{array}{r}
 11\text{-inch form} \\
 \times 6 \text{ LPI} \\
 \hline
 66 \text{ tape sprocket holes per form}
 \end{array}$$

NOTE

Limit of format tape length is from 5.5 to 12.5 inches
(139.7 to 317.5 mm or 55 to 125 sprocket holes).

- b) If the result is less than 55, the punching pattern for the form must be repeated until the sprocket holes of the patterns total 55 or more. Starting at previously punched top-of-forms hole, use the result and count that number of sprocket holes down the tape. This location is the next top-of-forms position which must be punched. When punching is complete, use the result to determine where tape is to be cut. If two patterns were punched, tape must contain 2 times the result number of sprocket holes; or 3 times the number if three patterns were punched.
- c) If the result is 55 or more, no further punching is necessary. When spliced, tape must contain the same number of sprocket holes as result. Count the sprocket holes from punched end of tape and mark the location where tape is to be cut.

- 8) Align the location to be cut with groove below splicer arm. Lower splicer arm and draw cutting blade across tape.
- 9) To splice the tape, raise splicer arm and place tape ends over the punch sprocket pins so that the ends abut over the splicer-arm groove.
- 10) Remove adhesive backing from a format tape splice and position splice on sprocket pins so that it equally covers both ends of the tape.
- 11) Lower splicer arm and press arm to join tape ends with splice.
- 12) Remove tape from punch, turn tape inside out and apply a splice to that side. In applying the second splice, offset it slightly from the first (one or two drive sprocket holes) to reduce the abrupt change in thickness.
- 13) Turn tape inside out. Tape is now ready for installation in printer.



COMMENT SHEET

MANUAL TITLE 751-10 Terminal Subsystem, Volume 2 of 2

Hardware Maintenance Manual

PUBLICATION NO. 62962300 REVISION F

FROM: NAME: _____

BUSINESS
ADDRESS: _____

COMMENTS:

This form is not intended to be used as an order blank. Your evaluation of this manual will be welcomed by Control Data Corporation. Any errors, suggested additions or deletions, or general comments may be made below. Please include page number references and fill in publication revision level as shown by the last entry on the Record of Revision page at the front of the manual. Customer engineers are urged to use the TAR.

CUT ALONG LINE

PRINTED IN U.S.A.

AA3419 REV. 11/69

NO POSTAGE STAMP NECESSARY IF MAILED IN U. S. A.

FOLD ON DOTTED LINES AND STAPLE

STAPLE

STAPLE

FOLD

FOLD

FIRST CLASS
PERMIT NO. 8241
MINNEAPOLIS, MINN.

BUSINESS REPLY MAIL
NO POSTAGE STAMP NECESSARY IF MAILED IN U.S.A.

POSTAGE WILL BE PAID BY
CONTROL DATA CORPORATION
Technical Publications Department
2401 North Fairview Avenue
St. Paul, Minnesota 55113

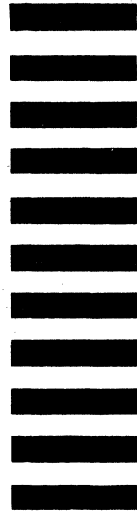

CUT ALONG LINE

FOLD

FOLD