



Control Data® 721-21/31 Owner's Manual

FCC Warning

This equipment generates, uses and can radiate radio frequency energy, and if not installed and used in accordance with the instructions manual, may cause interference to radio communications. It has been tested and found to comply with the limits for a Class A computing device pursuant to Subpart J of Part 15 of the FCC Rules, which are designed to provide reasonable protection against such interference when operated in a commercial environment. Operation of this equipment in a residential area is likely to cause interference in which case the user, at his own expense, will be required to take whatever measures may be required to correct the interference.

Pub. No. 62950101 B
©1983, by Control Data Corporation

All rights reserved. No part of this material may be reproduced by any means without permission in writing from the publisher. Printed in the United States of America.

Address comments concerning this manual to:

Control Data Corporation
Publications and Graphics Division
2401 North Fairview Avenue
St. Paul, Minnesota 55113

Canadian Department of Communications Office

The Canadian Department of Communications label identifies certified equipment. This certification means that the equipment meets certain telecommunication network protective, operational and safety requirements. The Department does not guarantee the equipment will operate to the user's satisfaction.

Before installing this equipment, users should ensure that it is permissible to be connected to the facilities of the local telecommunications company. The equipment must also be installed using an approved method of connection. In some cases, the company's inside wiring associated with a single-line individual service may be extended by means of a certified jack-plug-cord ensemble (telephone extension cord). The customer should be aware that compliance with the above conditions may not prevent degradation of service in some situations. Existing telecommunications company requirements do not permit their equipment to be connected to customer-provided jacks except where specified by individual telecommunications company tariffs.

Repairs to certified equipment should be made by an authorized Canadian maintenance facility designated by the supplier. Any repairs or alterations made by the user to this equipment, or equipment malfunctions, may give the telecommunications company cause to request the user to disconnect the equipment.

Users should ensure for their own protection that the electrical ground connections of the power utility, telephone lines and internal metallic water pipe system, if present, are connected together. This precaution may be particularly important in rural areas.

WARNING: Users should not attempt to make such connections themselves, but should contact the appropriate electric inspection authority, or electrician, as appropriate.

CAUTION: This terminal uses an eight-conductor cable with an eight-position miniature plug for connecting the terminal keyboard to the terminal display-unit housing. This plug must *never* be plugged into a telecommunications line (telephone line) jack. Such a connection would seriously damage the keyboard and might possibly render the telecommunications line inoperable.

NOTICE: Canadian regulations prohibit customer installation of internal options. In Canada, contact your local authorized Service Representative for installation of the Graphics Board, XA368A, and/or 1200/1200-Baud Internal Modem, XA360A.

FCC Requirements

Control Data Corporation
1200/1200-Baud Internal Modem
Model XA360-A

Installation of the 1200/1200-Baud Internal Modem

When you are ready to install the model XA360-A, call your local telephone company and give them the following information:

- The telephone number of the line to which you will connect the model XA360-A
- The FCC registration number of the model XA360-A
- The ringer equivalence number (REN) of the model XA360-A, which is 0.5B.

You can find the second and third of the preceding items on the label attached to the model XA360-A.

The model XA360-A connects to the telephone line by means of standard jacks called USOC RJ11C, RJ12C, or RJ13C. If these jacks are not available where you want to install the model XA360-A, you will need to order them from the telephone company.

Type of Service

Your model XA360-A is designed to be used on standard-device telephone lines. It should not be used on coin service lines or party lines.

If you have any questions about your telephone line, such as how many pieces of equipment you can connect to it, the telephone company will provide this information upon request.

Telephone Company Procedures

The goal of the telephone company is to provide you with the best service it can. In order to do this, it may occasionally be necessary for them to make changes in their equipment, operations, or procedures. If these changes might affect your service or the operation of your equipment, the telephone company will give you notice, in writing, to allow you to make any changes necessary to maintain uninterrupted service.

If Problems Arise

If any of your telephone equipment is not operating properly, you should immediately remove it from your telephone line, as it may cause harm to the telephone network. If the telephone company notes a problem, they may temporarily discontinue service. When practical, they will notify you in advance of this disconnection. If advance notice is not feasible, you will be notified as soon as possible. When you are notified, you will be given the opportunity to correct the problem and informed of your right to file a complaint with the FCC.

In the event repairs are ever needed on your model XA360-A, they should be performed by Control Data Corporation or an authorized representative of Control Data Corporation.

Disconnection

If you should ever decide to permanently disconnect your model XA360-A from its present line, please call the telephone company and let them know of this change.

Betriebsanleitung: CDC 721 Display Terminal

Das "Display Terminal" ist für eine Betriebsspannung von

120 V	50/60 Hz; 1.3 A und
220/240 V	50/60 Hz; 0.71 A

konstruiert.

Die erforderliche Netzumschaltung wird an der Rückseite nach Lösen der Schraube am Netzumschalter vorgenommen.

Das Netzanschlußkabel ist mit einem Schutzkontaktstecker versehen.

Auf richtige Netzspannung ist zu achten, da im anderen Falle das Gerät zerstört wird.

Die Netzwandsteckdose ist unmittelbar und leicht zugänglich, in der Nähe des Gerätes zu montieren.

Netzschalter:

Der Netzschalter befindet sich an der Frontseite.

Stellung gedrückt - O - AUS
Stellung gedrückt - I - AN

Der Gerätesicherungsautomat an der Rückseite, ist durch Eindrücken zu betätigen.

Weitere Bedienungseinrichtungen für

Reset
Kontrast
Helligkeit

befinden sich an der Frontseite.

Nach Einschalten der Netzspannung dauert es ca. 15 Sekunden bis der Bildschirm aktiviert ist.

Das Öffnen des Gerätes ist nur von qualifiziertem Fachpersonal nach Abschalten der Stromzufuhr zum Gerät, vorzunehmen. Beachten Sie die Wartungs- und Garantiebestimmungen.

Umgebungstemperatur:

10° C bis 40° C

Temperaturwechsel:

10° C innerhalb 1 Stunde

Relative Feuchtigkeit:

20% bis 80%

Gewicht:

inkl. Keyboard - 21.8 kg

Weitere Informationen entnehmen Sie dem Geräte -
Manual CDC Nr: 62 95 01 01

This manual provides installation and operation instructions for the CONTROL DATA® 721-21/31 Display Terminal and is intended for anyone that will set up or use the 721-21/31 Display Terminal. For easy reference, keep this manual near the terminal.

This manual has four sections:

- Section 1 **CUSTOMER PLANNING GUIDE** explains how to prepare the area where the display terminal will be used.
- Section 2 **INSTALLATION GUIDE** explains how to prepare the display terminal for use, how to run the display-terminal self tests, and how to modify preset installation parameters.
- Section 3 **OPERATING GUIDE** describes the normal everyday operations done by anyone using the display terminal.
- Section 4 **PROBLEM SOLVING GUIDE** contains instructions on how to correct problems that may occur, and what to do to obtain service for the terminal.

Ordering Information

You may order additional copies of this manual from:

Control Data Corporation
Literature and Distribution Services
308 North Dale Street
St. Paul, Minnesota 55103

If you have any questions regarding this publication or any of the Control Data publications made available to you, please talk to the Control Data salesperson handling the purchase of your display terminal.

CUSTOMER PLANNING GUIDE

Introduction	1-1
Your Responsibilities	1-2
Environment	1-2
Work Area	1-3
Lighting	1-5
Power Needs	1-6
Supplies	1-7
Planning Checklist	1-8
Product Information	1-9

INSTALLATION GUIDE

Display Terminal	2-1-1
Additional Items	2-2-1
Cable Connection	2-3-1
Parameter Settings	2-4-1

OPERATING GUIDE

Introduction	3-1
Overview	3-2
Power-On	3-3
Graphics Feature and Touchpanel	3-7
Switches, Lights, and Other Parts	3-10
Keycaps	3-15
Keyboard	3-18
Changing Keyboard and Screen Angle	3-20
Mode Selection Display	3-21
Using Modems	3-23
Sign-On Information	3-36
Using a Flexible-Disk Drive	3-38
Using a Memory Module	3-42
Changing Parameters	3-43
Operating in CYBER Mode	3-47
Cleaning the Keyboard and the Display Terminal	3-67

PROBLEM SOLVING GUIDE

Introduction	4-1
Screen Messages	4-2
Display Terminal HELP	4-15
Keyboard HELP	4-31
HELP 100	4-45

APPENDIX A

Terminal Installation Parameters	A-1
Mode Installation Parameters	A-12

APPENDIX B

Screen Realignment Without a Touchpanel Installed	B-1
Screen Realignment With a Touchpanel Installed	B-5

INDEX	Index-1
-------------	---------

Introduction

Your CONTROL DATA® 721-21/31 Display Terminal is a versatile terminal for use as a stand-alone unit or as part of a CDC® 110 Microcomputer System.

Your terminal may be:

- Included as part of a communications network
- Linked to a remote computer
- Cabled directly to a local computer
- Set up with a character or graphics printer

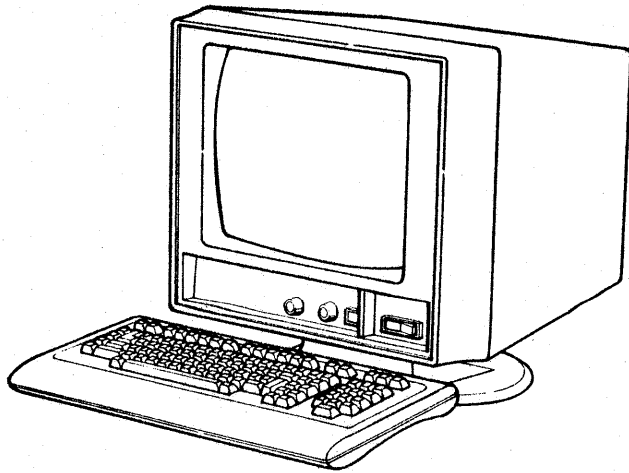

This customer planning guide was created to help you plan for installation of your display terminal. You should read this guide carefully before installing your terminal or before starting operation.

Your Responsibilities

When you buy a 721-21/31 display terminal and before you install it, you should:

- Use the planning checklist at the end of this section to make certain nothing is overlooked before installation so you can install and begin using your display terminal right away.
- Read the warranty that comes with your terminal and be sure you understand it.
- Keep this manual near the terminal for easy reference.

Environment

Your display terminal produces slightly more heat than a 100-watt bulb. Additional items connected to the terminal, such as a printer or a flexible-disk drive, will produce added heat. If your present cooling system is working fine, this added heat should cause no problems.

To get the best performance and the longest service life from your terminal, you should make sure it is operating within the following guidelines:

- Temperature: 10°C to 40°C (50°F to 104°F)
- Relative Humidity: 20% to 80%

CAUTION: Excessive static electricity can harm the terminal. If you have this problem, use static-proof carpeting, carpet spray, or increase room humidity. Also, heavy dust and vibration are harmful to your terminal.

Work Area

Prepare a steady, level surface for the terminal. An office table 30 inches by 60 inches by 26 inches high will give you plenty of work space and the best typing height for your keyboard.

You can also find specially designed tables for your terminal:

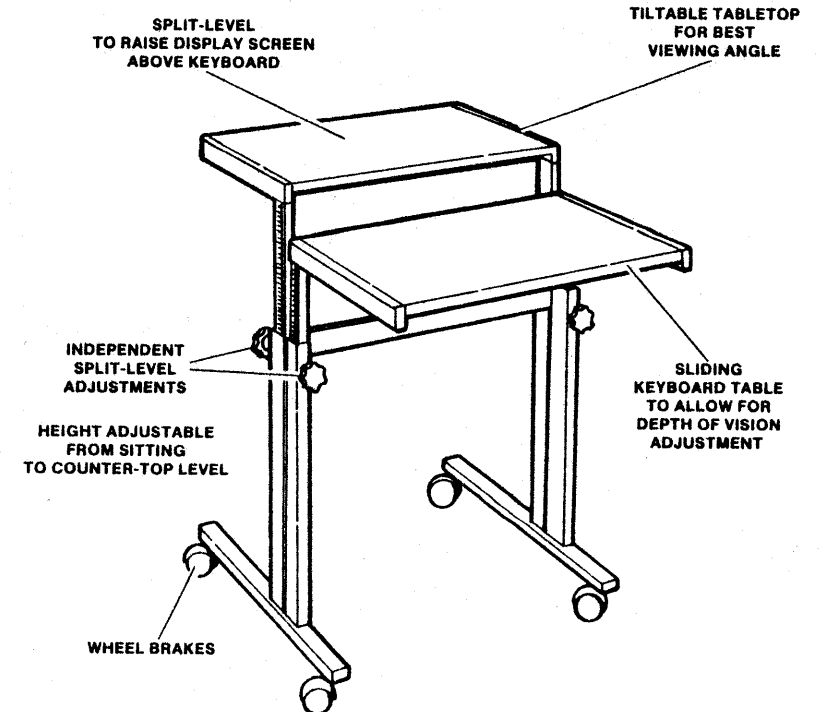

You need to allow enough space on the table for the terminal. Besides allowing space for the terminal, you must allow some extra space at the rear for power-cord connection and at the top and sides for air circulation.

The dimensions of the terminal are shown in the following illustration:

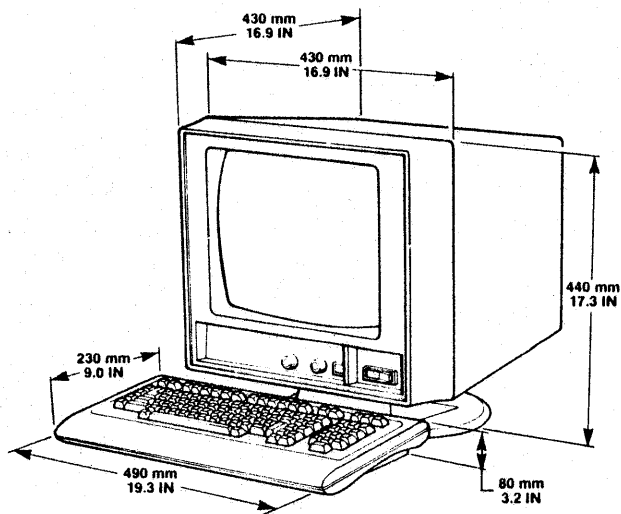

You need to allow additional space:

- At the rear: 4 to 6 inches
- At top and sides: 4 inches minimum

Lighting

What to Avoid

Adequate lighting is important. Avoid:

- Any bright lights that may reflect off the display screen and into your eyes.
- Any sunlight falling directly on your display screen. You might use curtains or screens to avoid this. You could also avoid this by turning the display terminal or the table on which it sits.

Good

“Soft” light bulbs or “soft” light covers, such as egg-crate covers, will scatter the light. The egg-crate covers can reduce the light near your terminal by 50 percent.

Better

A lighting wall control will let you dim the lights to about half of your normal office lighting.

Power Needs

You will need a three-prong power outlet for the power cord. In the United States, the power line (120 volts) should have a 15-ampere rating. The power line for 220- or 240-volt operations should have an equivalent rating. For 50-Hz operation at 220/240 V ac, the YA275-A power conversion kit must be ordered.

You will get the best performance from your display terminal if you make sure no heavy electrical loads that are repeatedly switched on and off (such as air conditioners, office copy machines, elevators, or arc welders) are connected to the same fuse box even though they may be on separate lines. If you have any doubts, an electrician can answer your questions.

An 8.5-foot power cord comes with the terminal. Allow approximately 3 feet of slack in the power cord to permit servicing.

CAUTION: Never try to defeat the purpose of the third prong (the safety ground) on any power cord by using adapters.

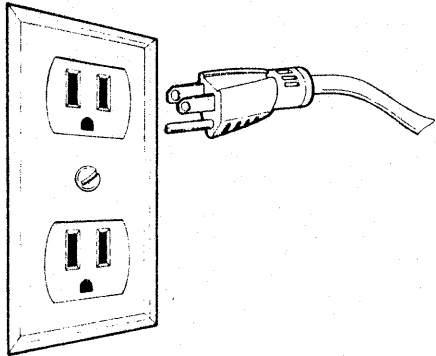

Supplies

The following items will help you to maintain the exterior of your terminal:

- Lint-free cloth or cleaning tissues, such as Kimberly-Clark Corporation's Kimwipes, or equivalent.
- A couple of small, soft-bristled brushes for dusting and cleaning the cracks and crevices in the equipment exteriors—particularly useful for cleaning the terminal keyboard. A vacuum cleaner equipped with a soft-bristled brush nozzle can be used in place of the brushes.
- A mild, commercially available cleaning solution that dries without leaving a residue or filmy deposits, such as Lan-O-Sheen Corporation's Brief spray cleaner, or equivalent.

CAUTION: Care must be taken when using a liquid cleaning agent. Do not allow any cleaning agent to run down the display screen or get into the keyboard.

Planning Checklist

Here is a planning checklist to help you prepare for installation of your terminal. When all boxes are checked, you will be ready to install the terminal.

Date Planned _____

- Read Customer Planning Guide. Check:
 - Environment
 - Work area
 - Lighting
 - Power outlet
 - Telephone access (one placed near operator)
- Order any special office furniture
- Make any required changes (environmental, lighting, power, telephone)
- Read Installation Guide section of this manual
- Unpack terminal, following the Unpacking Instructions shipped with it. (Save the original packing materials for future use.)
- Install display terminal

Product Information

Display Terminal and Keyboard

Power Requirements:

	60 Hertz	50 Hertz
Voltage	120	220/240
Amperes	1.3	0.7
Kilovoltamperes	0.16	0.17

Heat given off: 416 British thermal units per hour (122 watts, somewhat more heat than a 100-watt light bulb)

WEIGHT: 19.5 kg (43 lb), Display Terminal
2.3 kg (5 lb), Keyboard

KEYBOARD CABLE LENGTH: 1.5 m (5 ft)

POWER CORD LENGTH: 2.6 m (8.5 ft)

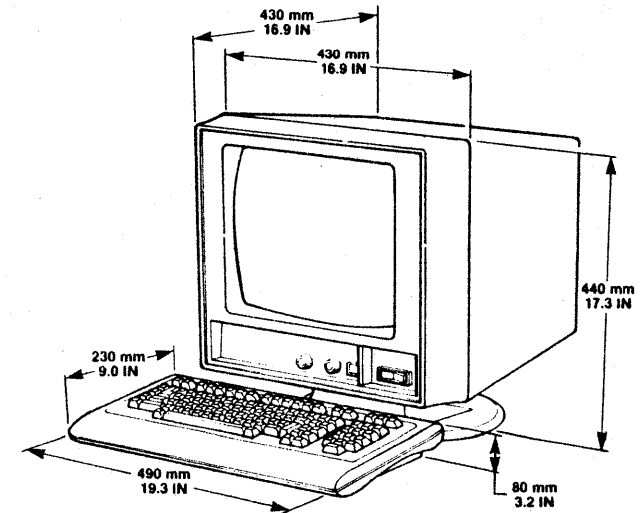

Introduction

This section shows you how to install and connect the units of your display terminal and how to test the terminal as it is installed. Doing these tests tells you if your terminal is working properly and also acquaints you with your terminal.

This section assumes you have unpacked your terminal, following the Unpacking Instructions shipped with it.

Equipment Identification Number

Your Unpacking Instructions were shipped in a plastic envelope attached to the display terminal carton. A second plastic envelope attached to the carton contains a tag that looks like this:

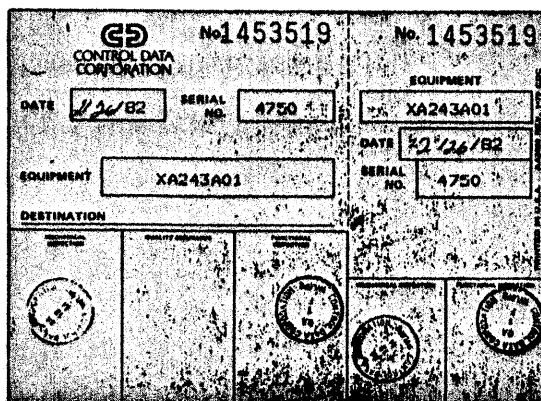

On the tag in the equipment box is a group of two letters, three numbers, a letter, and two more numbers. This is the Equipment Identification Number of the terminal. The first five characters should read either CC634 or CC638.

You should locate the Equipment Tag fastened to the back of your terminal. It also lists the Equipment Identification Number. A typical Equipment Tag looks like this:

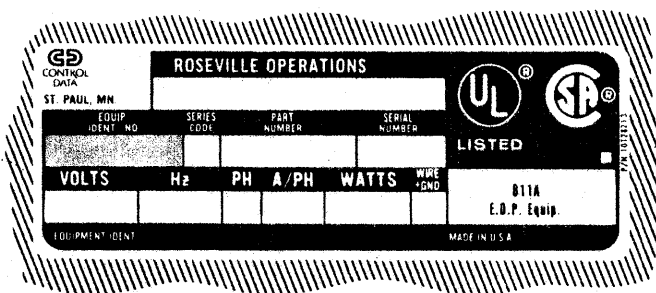

Connecting the Keyboard and the Power Cord

- 1 With someone helping you, lay the display terminal on its right side so the left side is facing up. Then plug the cord from the keyboard into the connector on the bottom of the terminal. Note that the plastic clip on the plug points toward the front of the terminal.

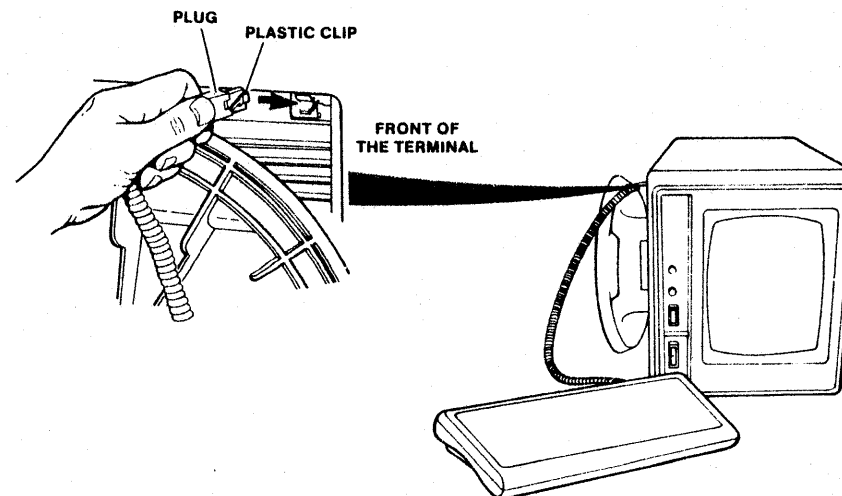

- 2 With the keyboard plugged in, place the display terminal in an upright position and find the POWER switch on the front of the terminal. Press the side marked with a 0 on the POWER switch to be sure the terminal is turned off.

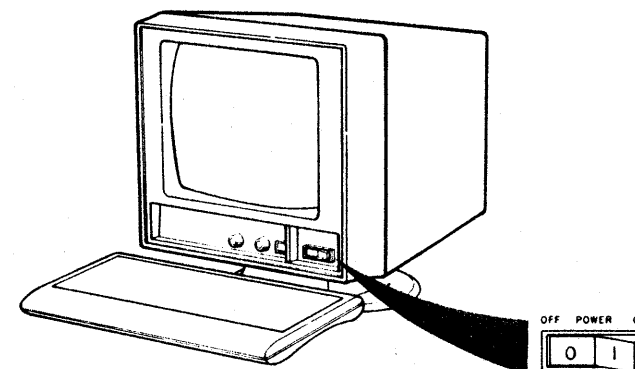

- 3 Look at the upper-left corner of the back of the terminal. If your terminal is being used in the United States, check that the line voltage switch is set so 115 V shows through the small opening.

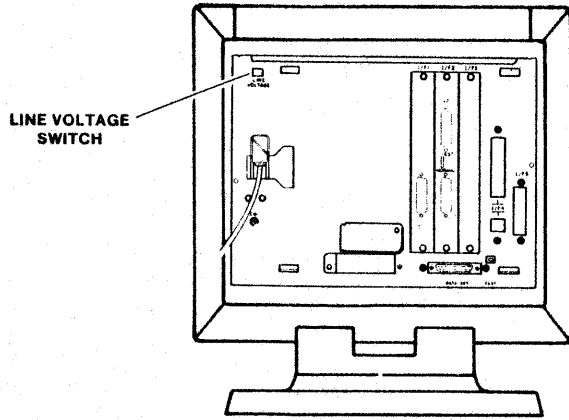

CAUTION: The terminal is shipped from the factory set up for 120-V ac, 60-Hz operation. For 50-Hz operation at 220/240 V ac, the YA275-A power conversion kit must be installed following the instructions included in the kit, or damage to the terminal may result.

- 4 Connect the power cord to the back of the display terminal. If the access-cover latch is blocking the power connector, push the latch down. Do not connect the cord to electrical power at this time.

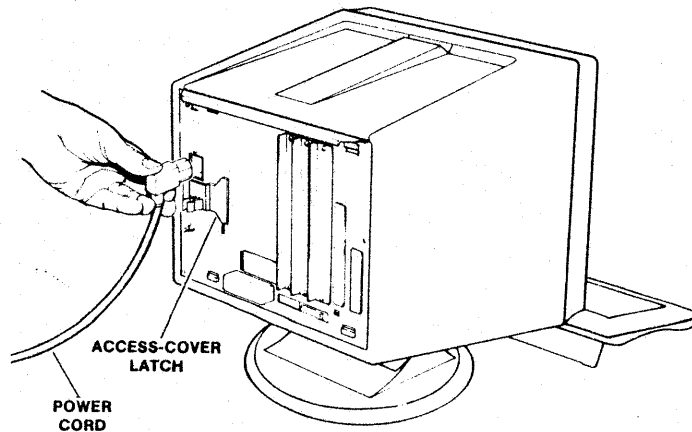

You are now ready to run the display terminal self test.

Self Test

- 1 Pull out the TEST switch at the back of the terminal.

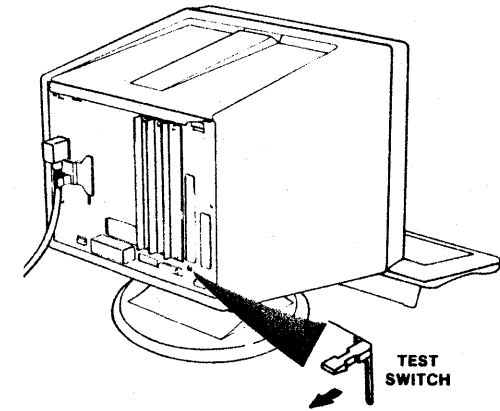

- 2 Plug the power cord from the display terminal into the electrical outlet you have selected.

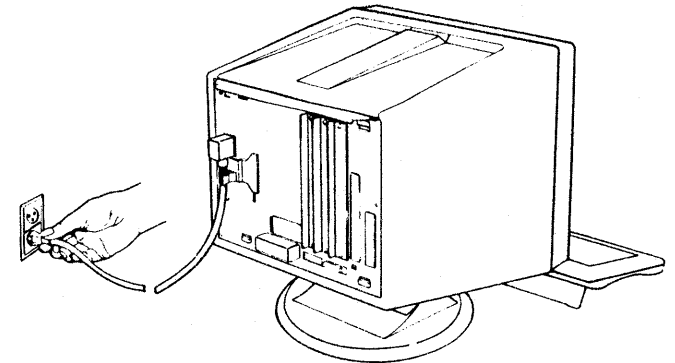

- 3 Turn on the terminal by pressing the side of the POWER switch marked with a 1.

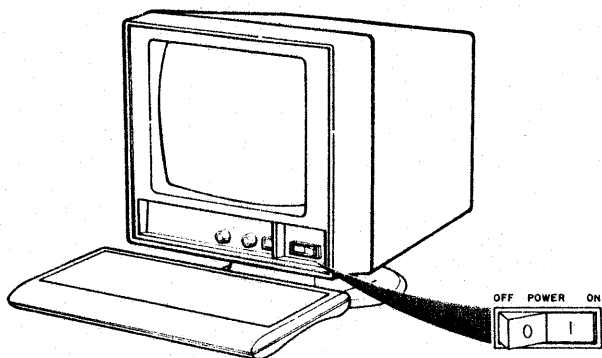

The terminal does a self test. The test takes a few seconds. When the test is done, the alarm sounds (a high-pitched beep). In about 20 seconds the terminal warms up, and the screen looks like this:

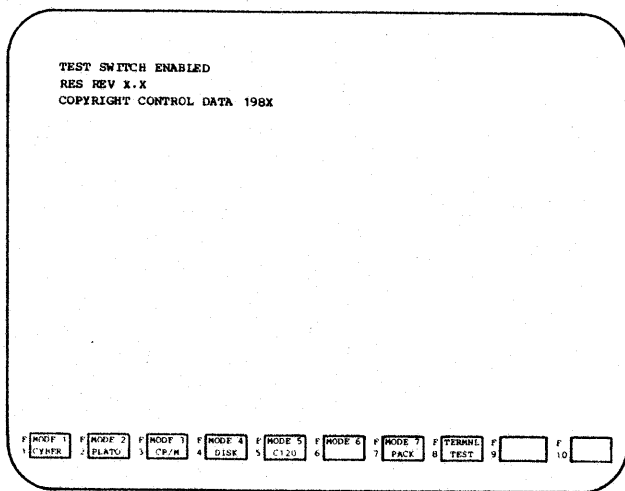

NOTE: X's represent numbers that may vary.

If you do not see TEST SWITCH ENABLED on the screen or the row of lighted blocks, adjust the BRIGHTNESS and CONTRAST controls clockwise.

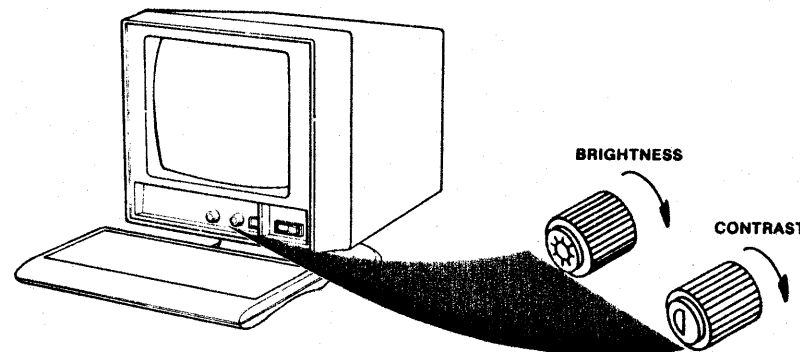

If you cannot make TEST SWITCH ENABLED and the row of lighted blocks appear, go to the Display Terminal HELP in the Problem Solving Guide. If a FAIL message appears on the screen, go to the Screen Messages in the Problem Solving Guide.

- 4 When TEST SWITCH ENABLED shows on the screen, push in the TEST switch at the back of the terminal.

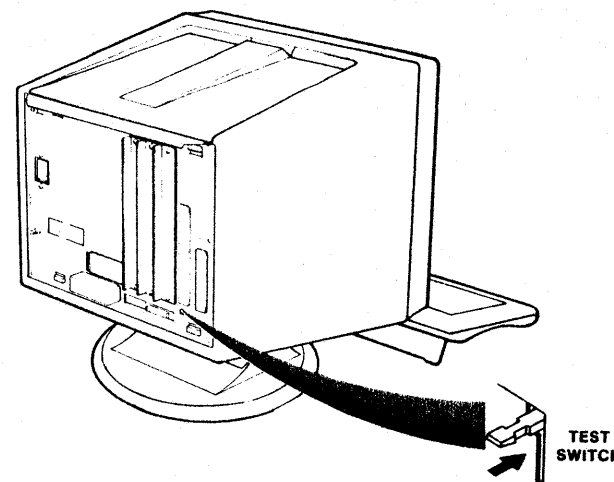

- 5 What happens next depends upon the type of display terminal you have. Find the equipment tag on the back of the display terminal. Locate the equipment identification number on this tag. If the first five characters are CC634, you have a CC634 Display Terminal. If the first five characters are CC638, you have a CC638 Display Terminal.

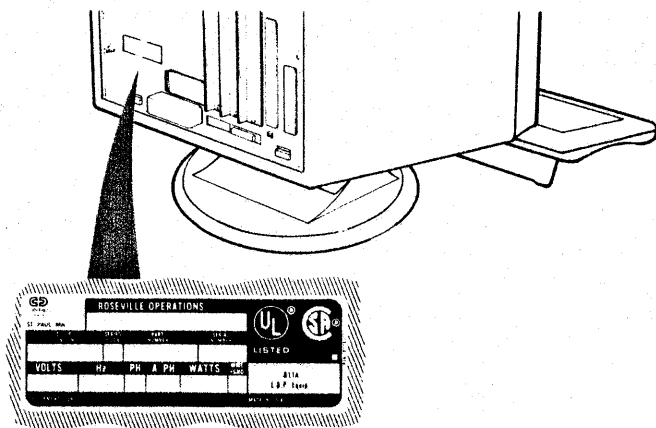

- 6 Press the RESET switch.

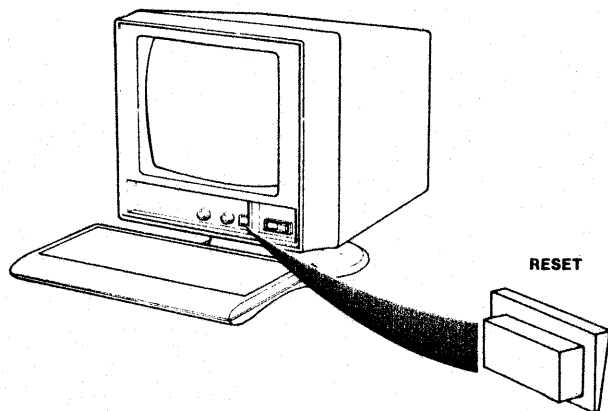

On a CC638 Display Terminal, a fast-changing series of patterns appears on the screen before the row of lighted blocks reappears at the bottom of the screen. Any time you reset the terminal this series of patterns will appear.

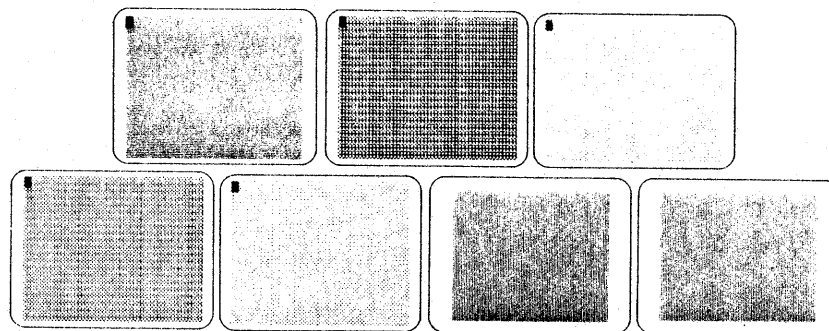

On a CC634 Display Terminal, the row of lighted blocks appears and you will not see the series of patterns.

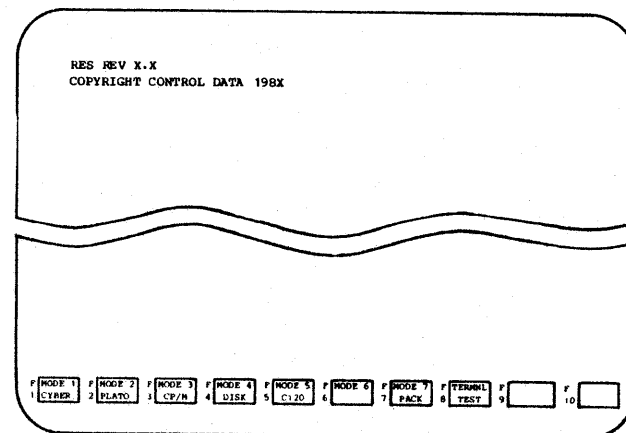

If your terminal does not act as described in the previous steps, go to the Display Terminal HELP in the Problem Solving Guide. When the terminal works as described, it has passed the self test.

You are now ready to run the display terminal operation test.

Operation Test

The operation test checks the display screen, front-panel lights, keyboard, communications circuits, and screen alignment. The test relies on you to verify that all items in the test are working properly.

- 1 When you completed the display terminal self test, a row of lighted blocks appeared on the screen. These blocks are called the Mode Selection display.

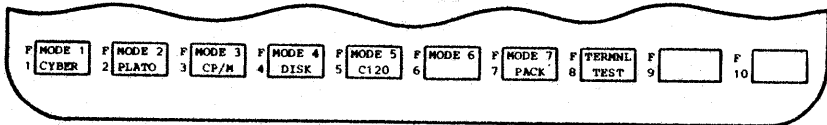
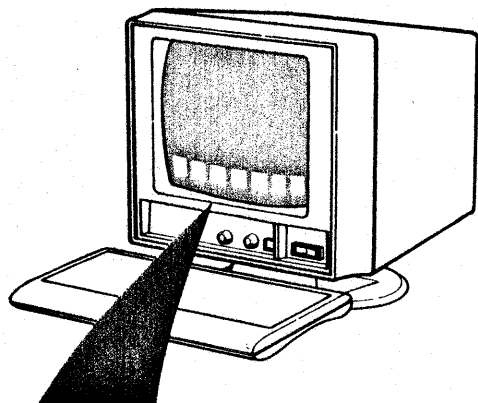

- 2 Press the F8 key to select the TERMINAL TEST.

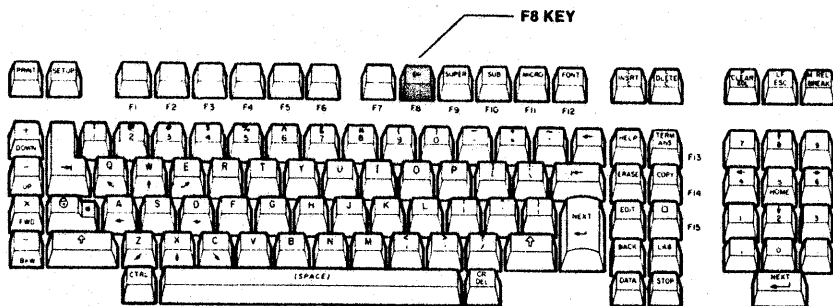

- 3 If you have a CC634 Display Terminal, skip this step. If you have a CC638 Display Terminal, a display of vertical lines appears with the lines alternately going on and off near the bottom of the screen. Press the F8 key again. The screen then appears as shown in step 4.

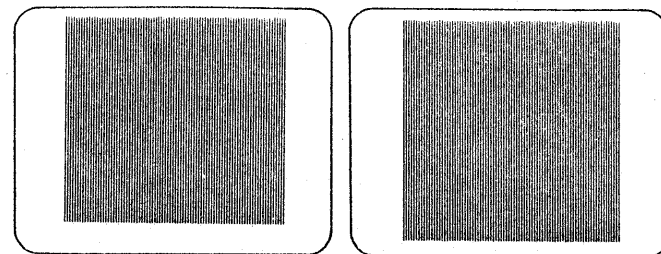

- 4 The screen that appears, as shown in the next illustration, has:

- An alignment border that should appear in line with the corner notches.
- Seven lines of symbols
- A line with the words:

BLINK—that should be blinking
DIM—that should be less bright
UNDERSCORE—that should have a line under it
INVERSE—that should be in dark characters on a light background

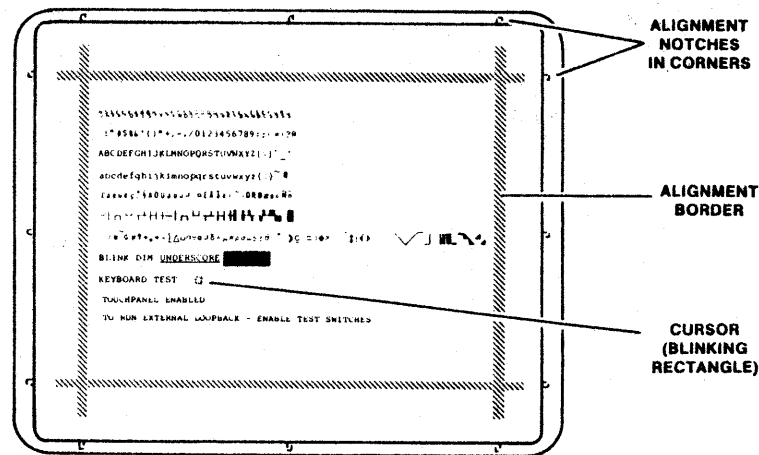

The word **BLANK** should not appear on the screen after the word **INVERSE**. If the word **BLANK** appears, turn to the Screen Messages in the Problem Solving Guide.

The following should also appear on the screen:

KEYBOARD TEST - with a cursor (small blinking rectangle) two character positions to the right

TOUCHPANEL ENABLED - even if the terminal does not have a touchpanel (only CC638 terminals have touchpanels)

TO RUN EXTERNAL LOOPBACK—ENABLE TEST SWITCHES

- 5 While the test is active, the red and green lights on the front panel should come on one after another in a repeating cycle.

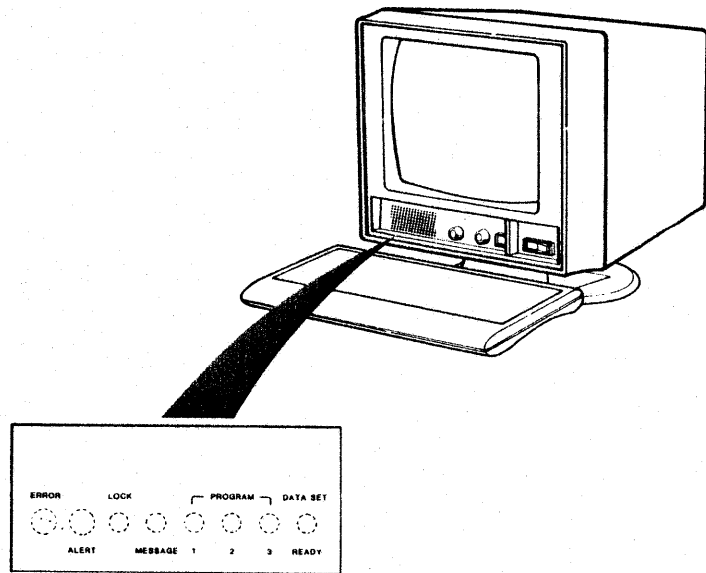

- 6 To check the keyboard, hold the **PRINT** key down and look at the two characters that appear on the screen after the words **KEYBOARD TEST**. A 10 should appear on the screen when you hold the **PRINT** key down.

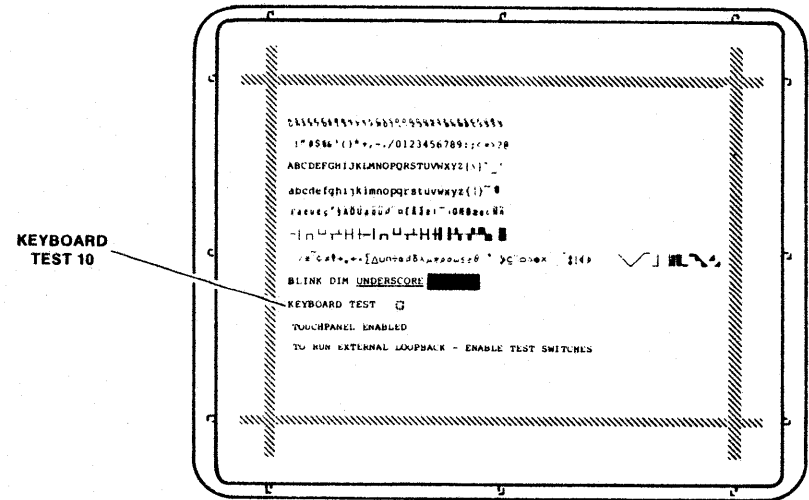
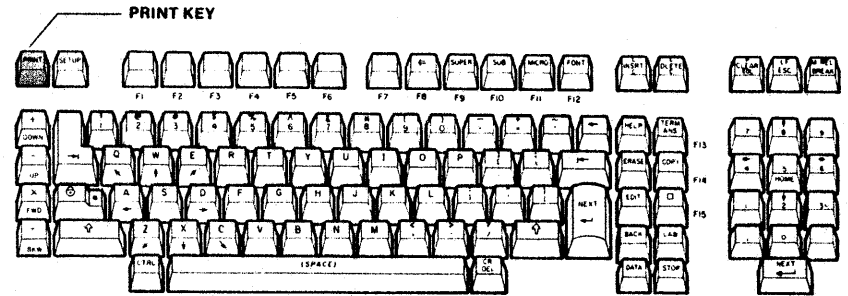

- Release the PRINT key and look at the two characters on the screen. A 90 should appear on the screen when you release the PRINT key.

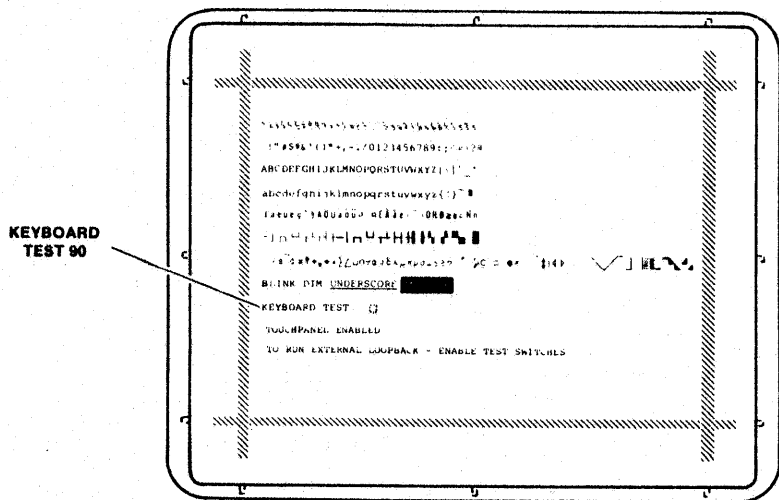

- Use the following Key-Code Table to check the rest of the keys on your keyboard. When you hold a key down, check that the two characters on the screen are the same as those shown for the key under the DOWN column in the table. When you release the key, check that the two characters on the screen are the same as those shown for the key under the UP column in the table.

KEY-CODE TABLE

KEY	DISPLAYED CODE		KEY	DISPLAYED CODE		KEY	DISPLAYED CODE	
	DOWN	UP		DOWN	UP		DOWN	UP
PRINT	10	90	O	63	E3	CTRL (SPACE)	25	A5
F1	18	98	P	6B	EB	CR DEL	2D	AD
F2	20	A0	[73	F3	HELP	35	B5
F3	28	A8		7B	FB	TERM ANS	6E	EE
F4	30	B0	-	7F	FF		36	B6
F5	38	B8	X	12	92	ERASE	77	F7
F6	40	C0	⊙	1A	9A	COPY	6F	EF
F7	48	C8	A	22	A2	EDIT	5F	DF
F8	50	D0	S	2A	AA	□	55	D5
F9	58	D8	D	32	B2	BACK	5D	DD
SUPER	60	E0	F	3A	BA	LAB	56	D6
SUB	68	E8	G	42	C2	DATA	45	C5
MICRO	70	F0	H	4A	CA	STOP	4D	CD
FONT	78	F8	J	52	D2	INSRT	7D	FD
+	11	91	K	5A	DA	DLETE	75	F5
- *	19	99	L	62	E2	CLEAR	6D	ED
1	21	A1	:	6A	EA	ESC	37	B7
2	29	A9	;	72	F2	BREAK	1D	9D
3	31	B1		7A	FA	7	16	96
4	39	B9	NEXT*†	67	E7	8	1E	9E
5	41	C1	÷	14	94	9	26	A6
6	49	C9	↑*†	1C	9C	4	17	97
7	51	D1	↑*†	24	A4	5	1F	9F
8	59	D9	Z	2C	AC	6	27	A7
9	61	E1	X	34	B4	1	4F	CF
0	69	E9	C	3C	BC	2	47	C7
=	71	F1	V	44	C4	3	3F	BF
=	79	F9	B	4C	CC	,	4E	CE
*	7E	FE	N	54	D4	0	46	C6
-	76	F6	M	5C	DC	.	3E	BE
.	13	93	.	64	E4	NEXT†	3D	BD
- *	1B	9B	.	6C	EC	NUMERIC PAD		
Q	23	A3	?	74	F4			
W	2B	AB	↑†	7C	FC			
E	33	B3	NEXT*†	66	E6			
R	3B	BB						
T	43	C3						
Y	4B	CB						
U	53	D3						
I	5B	DB						

*These keys may be covered with double-size keycaps. Pressing a double-size keycap displays the code for only one of the keys.

†There is more than one key with this symbol.

- 9** Skip this step if you have a CC634 display terminal. If you have a CC638 display terminal, you have a touchpanel covering the display terminal screen. When you touch the touchpanel while TOUCHPANEL ENABLED shows on the screen, the cursor should move close to where the touch was made. The touchpanel is not as large as the display screen, so there will be no response to touches at the edges of the display screen. (If the cursor does not move, go to the Display Terminal HELP in the Problem Solving Guide.)

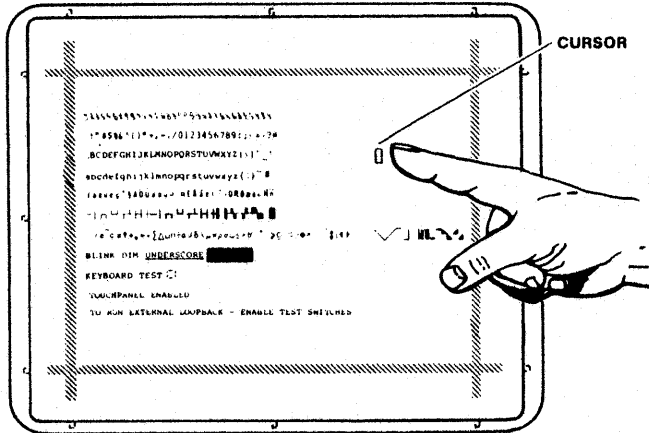

- 10** To check the communications circuits, pull out the TEST switch at the back of the terminal.

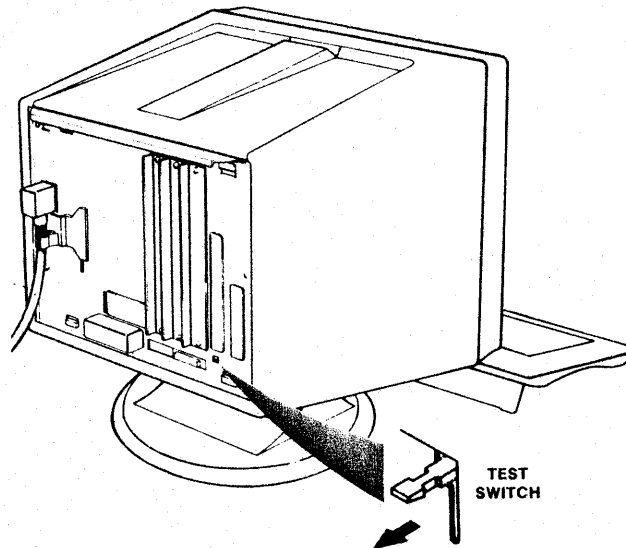

- 11** The screen should appear like this:

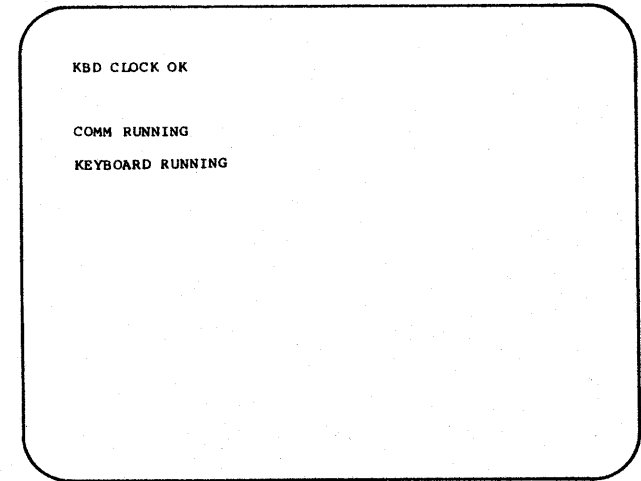

NOTE: If the word FAIL appears after any of the test names, for example, KBD CLOCK FAIL, go to the Screen Messages in the Problem Solving Guide.

- 12** Push in the TEST switch at the back of the terminal. End the operation test by pressing the RESET switch.

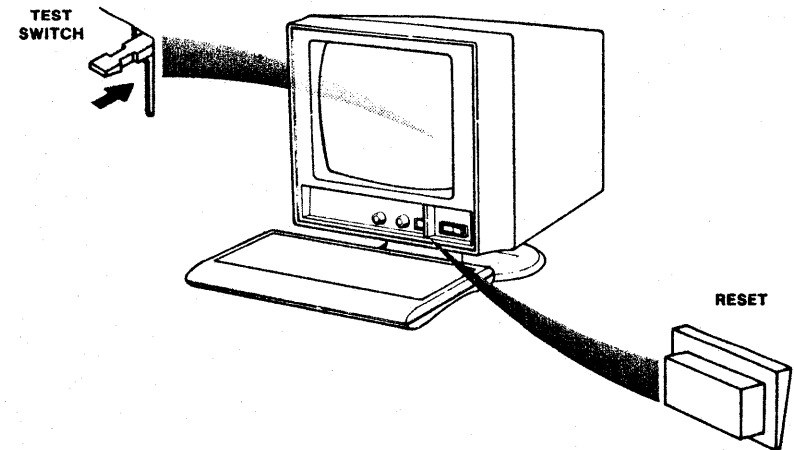

- 13** Turn the terminal off by pressing the side of the POWER switch marked with a 0.

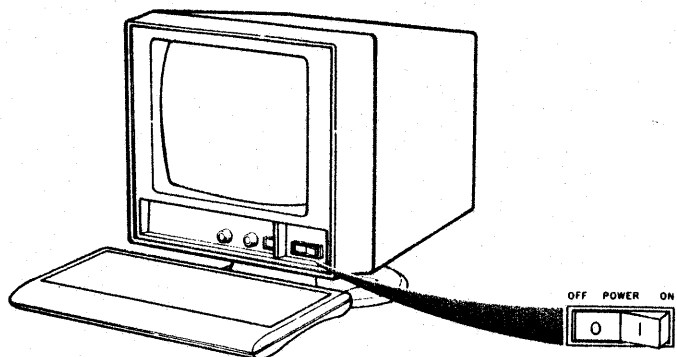

- 14** If you've reached this point, everything is going fine. Your display terminal has passed the operation test.

CONTINUE WITH THE NEXT SECTION.

Introduction

Now is the time to install any additional items you may be adding to your display terminal. This section shows you how to install the following items:

- 1200/1200-baud internal modem (XA360)
- Graphics board (XA368)
- Parallel-interface board (YR102)
- Serial-interface board (YR101)
- 401X graphics memory module (YR104)
- Keycap kit (YA274)

Check each item that you will be installing. Skip any instructions that do not apply.

1200/1200-Baud Internal Modem (XA360)

The terminal uses the internal modem to “talk” to a host computer or other terminals over the telephone lines.

CAUTION: Static electricity can damage the terminal. Do not stand on a carpeted surface while installing the internal modem.

- 1** Turn off power to the terminal by pressing the side of the POWER switch marked with a 0. Turn off power to any devices connected to the terminal.
- 2** Unpack the carton that has XA360 (as the first five characters in the EQUIPMENT box) on the green tag in the attached plastic envelope. You will find a printed-circuit board in a conductive envelope, a package containing a jumper cable and hardware, a duplex adapter, a telephone-line extension cord, and a screwdriver. Do not remove the printed-circuit board from its conductive envelope.

Discard the jumper cable. (The cable is only used when a Customer Engineer installs the internal modem in a earlier type terminal.)

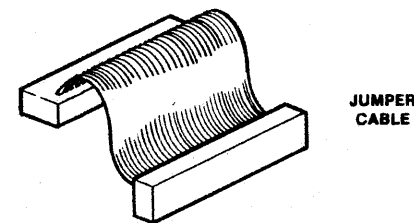

JUMPER
CABLE

- 3** Disconnect the power cord from the electrical outlet and from the back of the terminal. Disconnect any cables connecting devices to the terminal. You may want to tag the cables to make reconnecting them easier.

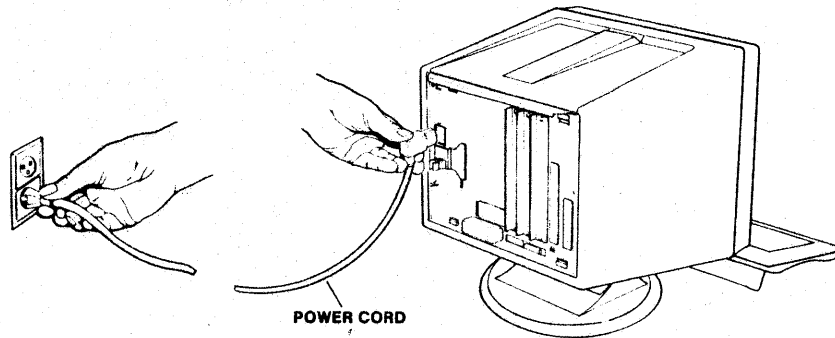

- 4** Lay the terminal on its right side so the left side is facing up. Press the plastic clip on the cable connector from the keyboard and unplug the connector.

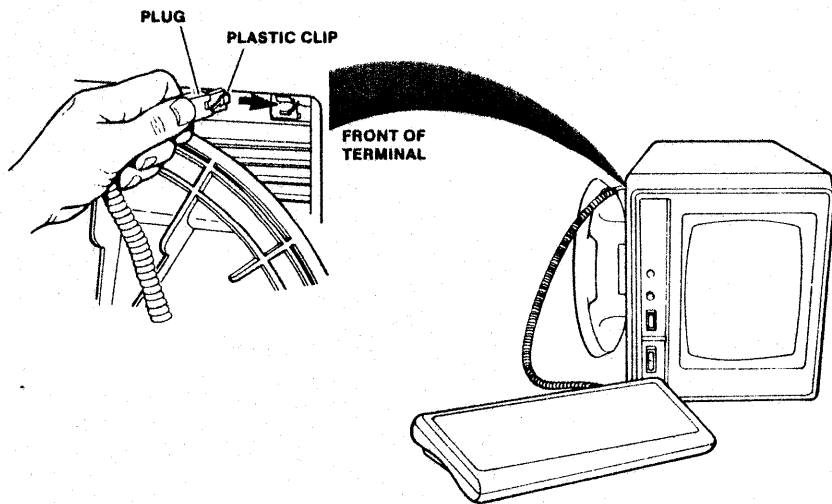

- 5** Place the terminal in an upright position. Then push the latch up as far as it will go.

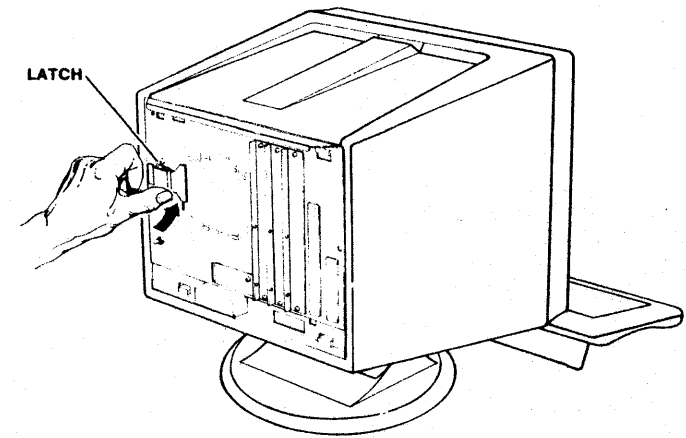

- 6** Remove the two screws from the back of the terminal. Save the screws.

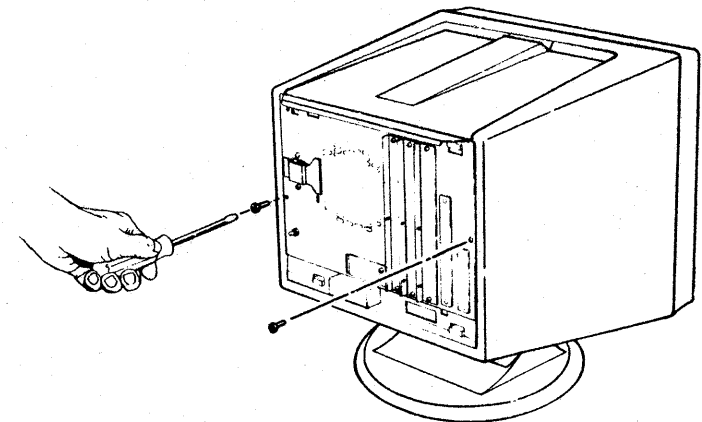

- 7** Remove the two screws that hold the access cover in place and remove the access cover. Save the screws. (If the access cover does not lift off easily, gently press down on the cover to release the internal catch.)

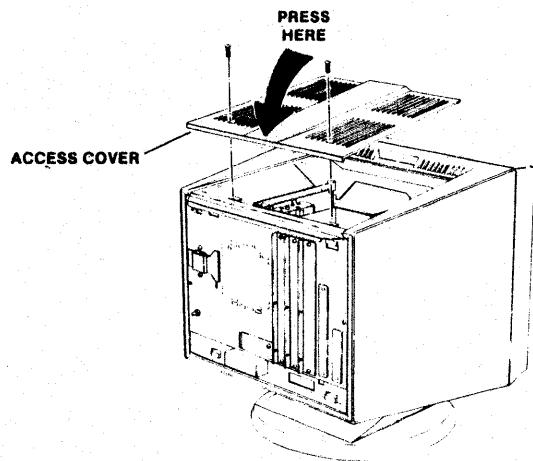

- 8** Check to see if the terminal has the white tab shown by the illustration. If the terminal does not have the white tab, skip this step. If the terminal does have the tab, pull up on the tab to disconnect the flat cable attached to the graphics board.

NOTE: The white tab indicates that the terminal has a graphics board and touchpanel.

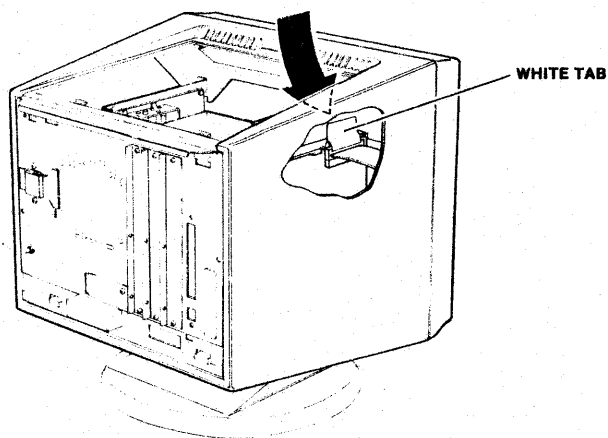

- 9** Locate the coverplate at I/F-4. Insert a slot-head screwdriver in the slot and pry off the coverplate. Discard the coverplate.

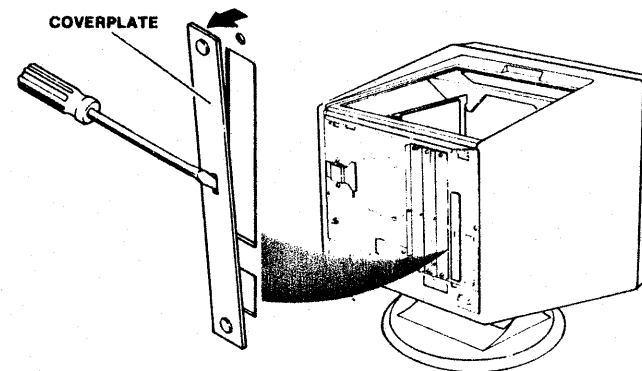

- 10** Give the drawer an initial hard pull to loosen it. Then carefully slide out the drawer assembly. (Be sure to support the drawer assembly as you slide it out of the terminal.) Set the drawer on your work table with the back of the drawer assembly facing away from you.

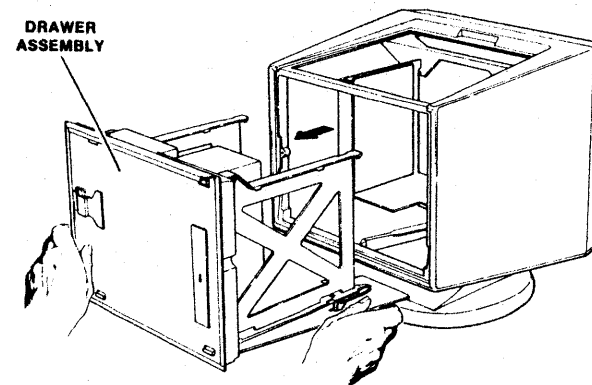

- 11** Remove the modem board from its conductive envelope. Save the envelope for possible future use. Then locate the printed-circuit board holder. The modem board slides in on the right-hand side of the board holder. Look at the modem board. It consists of two boards attached together. When you insert the modem board, the smaller board should face the inside of the drawer.

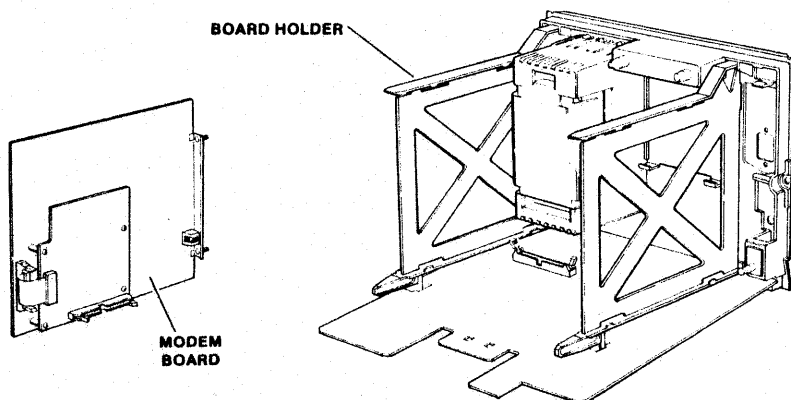

- 12** Carefully lift up on the catch and insert the modem board in the printed-circuit board holder. Release the catch and slide the board in until the catch snaps over the end of the board. Check that the board is locked in place and secured by the catch.

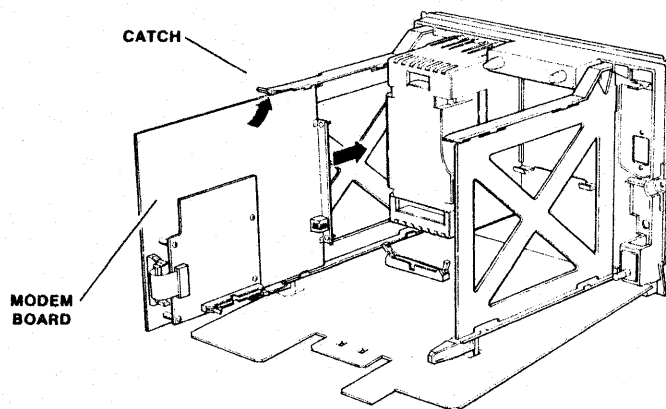

- 13** Locate the board connector on the modem board. Locate the cable connector attached to the flat cable. Plug the cable connector onto the board connector. (It may be necessary first to disconnect the outside end of the cable to have enough space to hold the cable.) Then check that the locking tabs on the cable connector are flat against the sides of the connector.

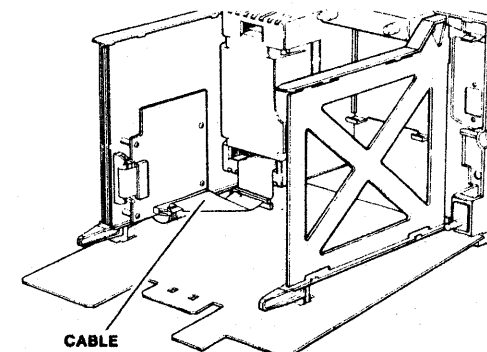

NOTE: If you also have a graphics board to install, unpack the graphics board (XA368), and then go to step 9 of the graphics board installation procedure (following this section). Complete steps 9 through 12 of the graphics board procedure. Then return here and complete the remaining steps of the modem board procedure.

- 14** Locate the center drawer slide. When you start to put the drawer assembly back into the terminal, this drawer slide aligns with a guide on the underside of the drawer assembly.

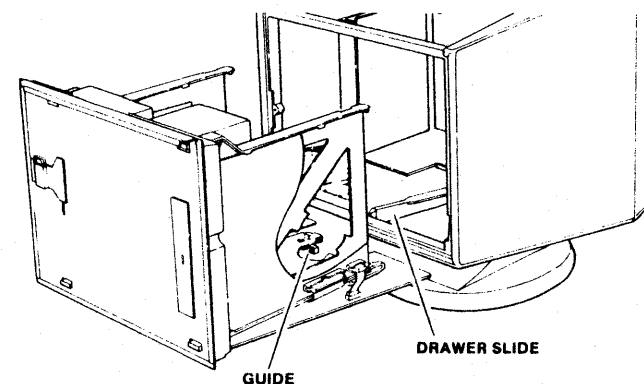

- 15** Pick up the drawer assembly and carefully insert it back into the terminal. As you insert the drawer, be aware of the wires on the left side of the drawer assembly. These wires can be snagged, so guide them with your hand if necessary. If the terminal has a touchpanel, hold the flat cable with the white tab (removed in step 9) to the right as you insert the drawer assembly. Hold the terminal and give the drawer a final push to seat it.

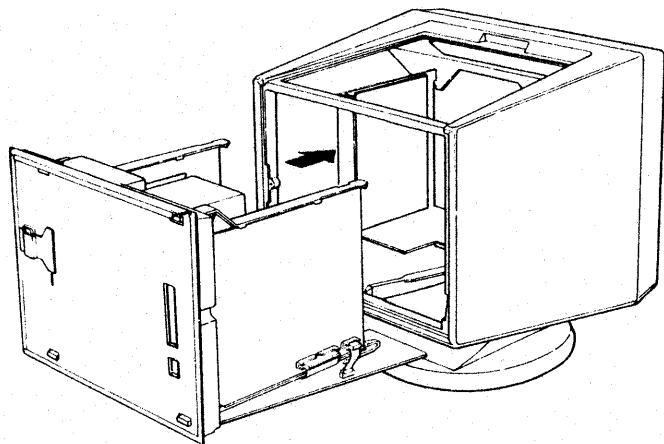

- 16** Locate the modem at I/F-4. You can see the FCC label and the Canadian Department of Communications label on the modem. The RJ11C phone-jack connector is at the smaller slot. Tighten a nut on each of the bolts.

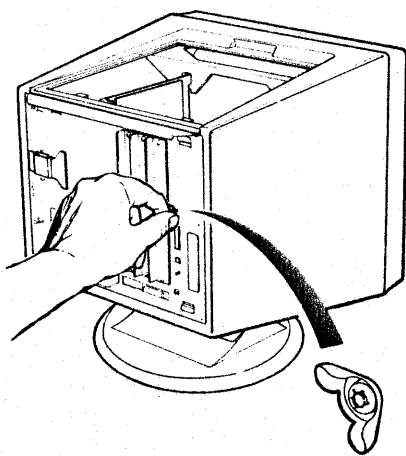

- 17** If the terminal has a touchpanel, push the connector attached to the white tab down onto the connector on the graphics board. (Be sure both ends of the connector are pushed down.)

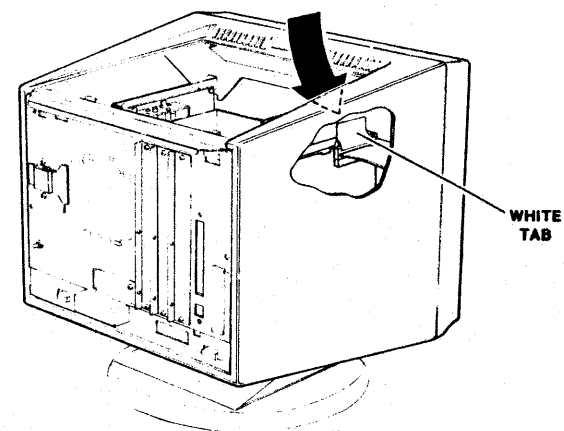

- 18** Replace the access cover and the two access-cover screws. Push down the latch that holds the cover in place. Replace the two screws on the back of the terminal.

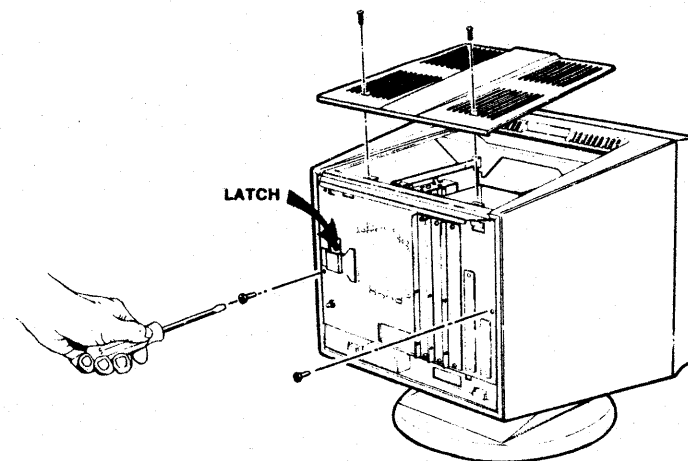

19 Record the following information on the equipment configuration log on the back of the terminal:

- Equipment identification number: XA360
- Series code: last two characters in the EQUIPMENT box on the green tag (in the plastic envelope attached to the carton)
- Serial number: characters in the SERIAL NO. box on the green tag
- Date of installation and your name

If you also installed a graphics board, record the following information on the equipment configuration log on the back of the terminal:

- Equipment identification number: XA368
- Series code: last two characters in the EQUIPMENT box on the green tag (in the plastic envelope attached to the carton)
- Serial number: characters in the SERIAL NO. box on the green tag
- Date of installation and your name

EQUIPMENT CONFIGURATION LOG			
CONTROL DATA		BASE EQUIP. ID NO.	S/N
EQUIP. ID NO.	SERIAL NO.	*CHANGE NO.	DATE AND INSTALLED BY

AA7911-1 Rev. 3/82 EQUIPMENT COPY * KEY FOR CHANGE NO. PREFIXES
 F - FCO E - ECO D - A (DEVIATION)

EQUIPMENT IDENTIFICATION NUMBER AND SERIES CODE

SERIAL NUMBER

DATE OF INSTALLATION AND YOUR NAME

20 Lay the terminal on its right side so the left side is facing up. Then plug the cable from the keyboard into the connector on the bottom of the terminal. Note that the plastic clip on the plug points toward the front of the terminal.

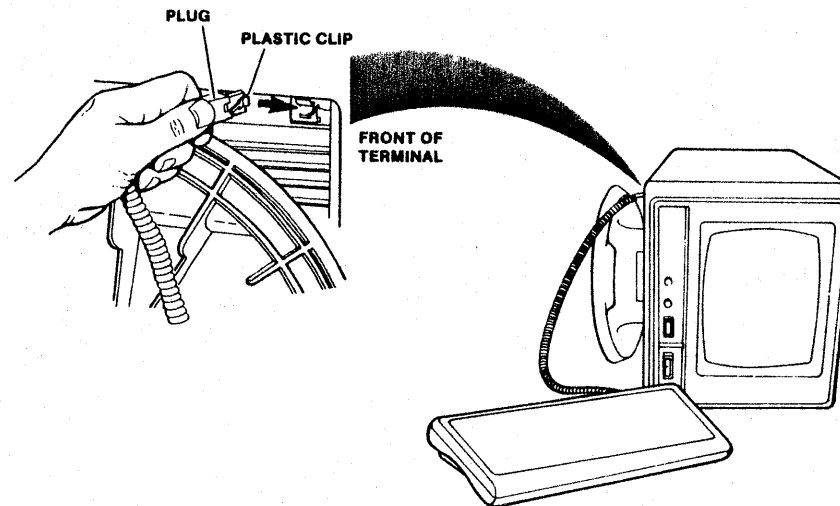

21 Place the terminal in an upright position. Connect any cables removed in step 3. Connect the power cord to the back of the terminal and press the power cord into the cable retainer on the latch. Connect the power cord from the terminal to the electrical outlet.

Checkout

You have completed the physical installation of the internal modem. Follow these steps to check that the modem is working properly:

- 1** Turn on the terminal by pressing the side of the POWER switch marked with a 1.
- 2** The Mode Selection display appears on the screen. If you do not see the Mode Selection display:

a Pull out the TEST switch at the back of the terminal.

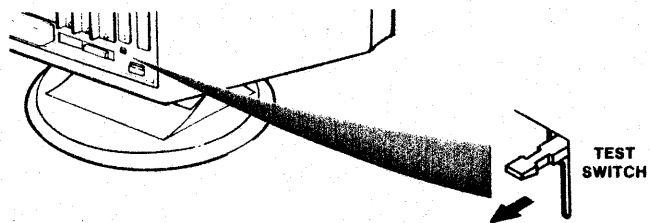

b Press the RESET switch at the front of the terminal.

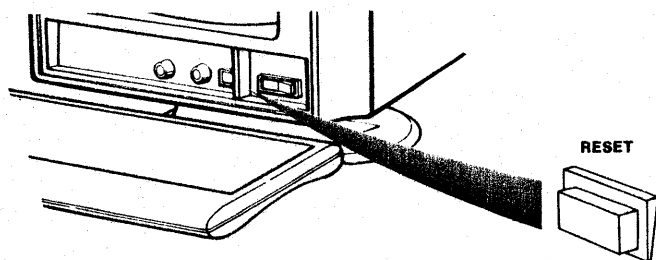

c Disregard the TEST SWITCH ENABLED message that appears with the Mode Selection display. Push in the TEST switch.

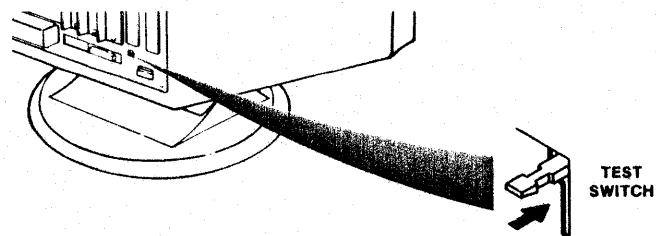

3 With the Mode Selection display on the screen, press and hold the CTRL (control) key while you press the SETUP key.

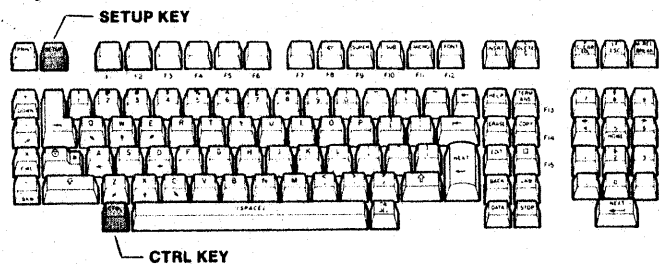

4 Press the F3 key and then type a 1 in position 1 of the F3 block.

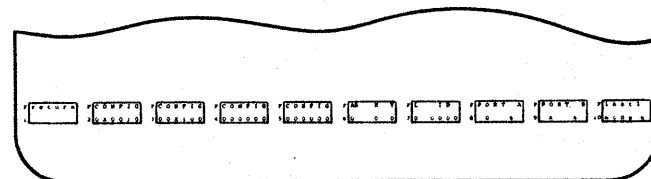
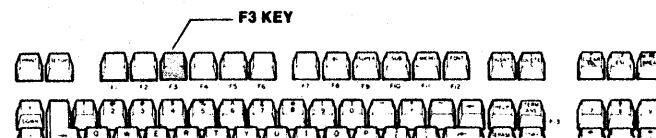

F	CONFIG
3	1 0 0 0 0

5 Press the F4 key. Then press the space bar twice to space to position 3. Type a 1 in position 3 of the F4 block.

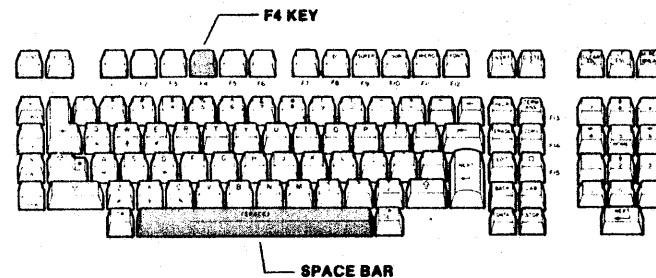

F	CONFIG
4	0 0 1 0 0

6 Press the COPY key.

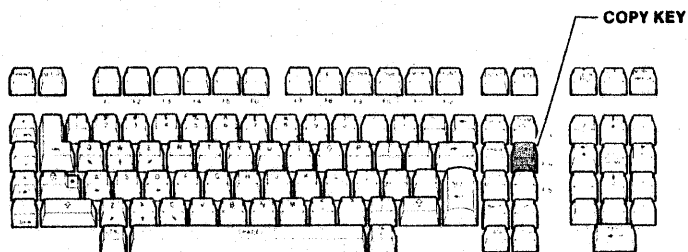

7 Press RESET to run the terminal self test. (The self test may take up to 20 seconds with the internal modem installed.) The screen looks like this if everything is working fine:

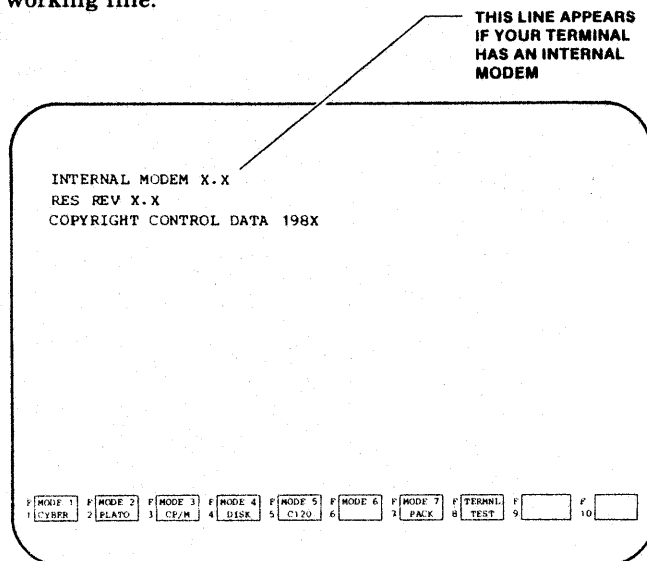

If INTERNAL MODEM LOOPBACK FAIL, INTERNAL MODEM CHECKSUM FAIL, or INTERNAL MODEM UART FAIL appears on the screen, remove the drawer assembly again and recheck all connections.

CAUTION: If the modem board is removed from the terminal, the board must be inserted into its conductive envelope.

If any of these messages appear again, go to **HELP 100** in the Problem Solving Guide.

If you have also installed a graphics board, go to Checkout at the end of the graphics board procedure and complete the steps.

NOTE: If the internal modem is the only item you are installing, turn to the Installation Record at the end of this section to record the installation of the modem. Then turn to the Cable Connection section to connect the modem to the telephone lines, and to Additional Parameters in the Parameter Settings section to set the parameters associated with the internal modem.

Graphics Board (XA368)

The terminal uses the graphics board to make drawings, graphs, and pictures.

CAUTION: Static electricity can damage the terminal. Do not stand on a carpeted surface while installing the graphics board.

- 1** Turn off power to the terminal by pressing the side of the POWER switch marked with a O. Turn off power to any devices connected to the terminal.
- 2** Unpack the carton that has XA368 (as the first five characters in the EQUIPMENT box) on the green tag in the attached plastic envelope. You will find a printed-circuit board in a conductive envelope, an interconnect cable, and a screwdriver. Do not remove the printed-circuit board from its conductive envelope. The printed-circuit board and interconnect cable look like this:

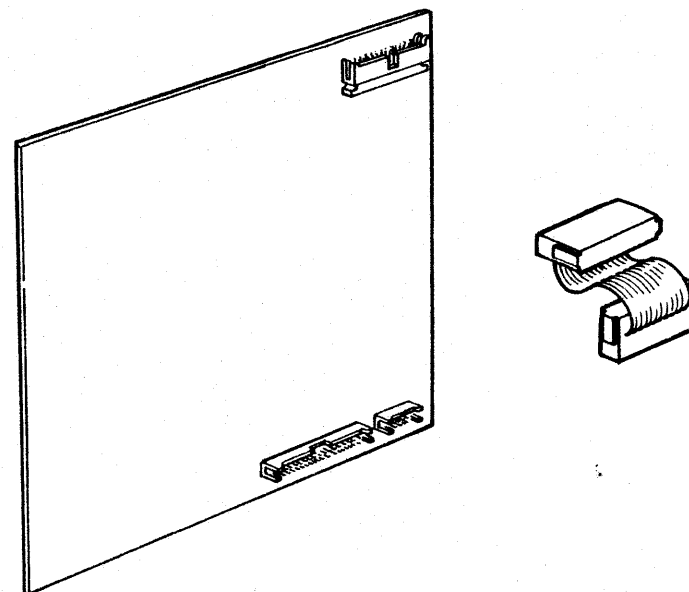

- 3** Disconnect the power cord from the electrical outlet and from the back of the terminal. Disconnect any cables connecting devices to the terminal. You may want to tag the cables to make reconnecting them easier.

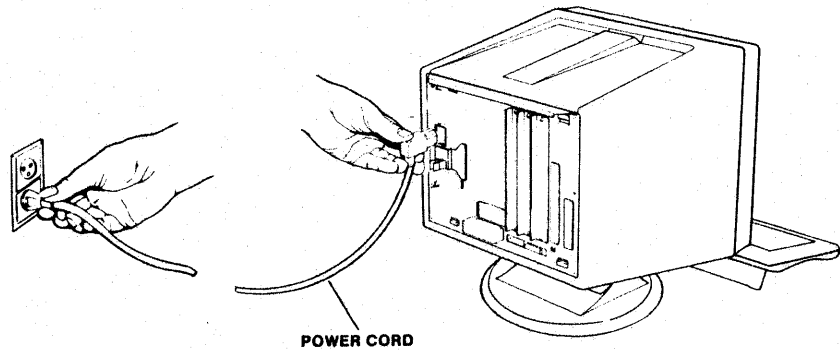

- 4** Lay the terminal on its right side so the left side is facing up. Press the plastic clip on the cable connector from the keyboard and unplug the connector.

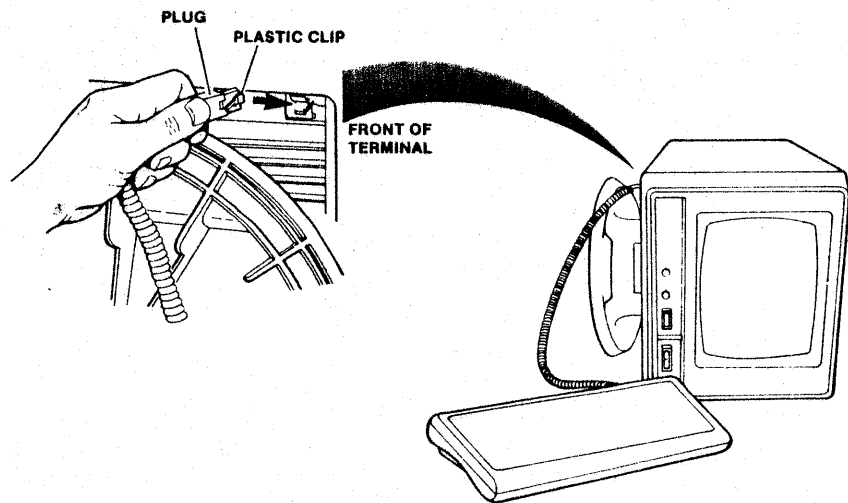

- 5** Place the terminal in an upright position. Then push the latch up as far as it will go.

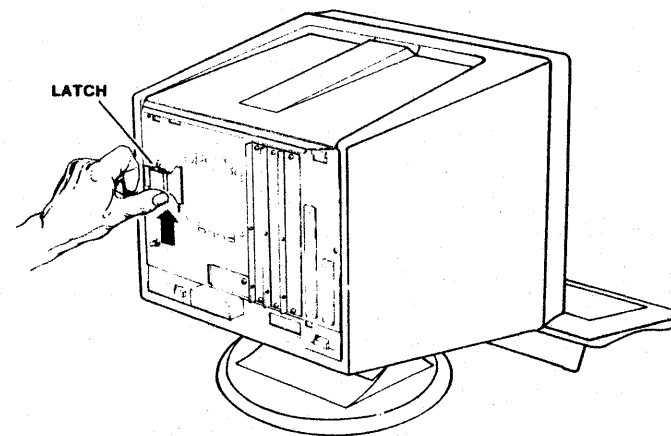

- 6** Remove the two screws from the back of the terminal. Save the screws.

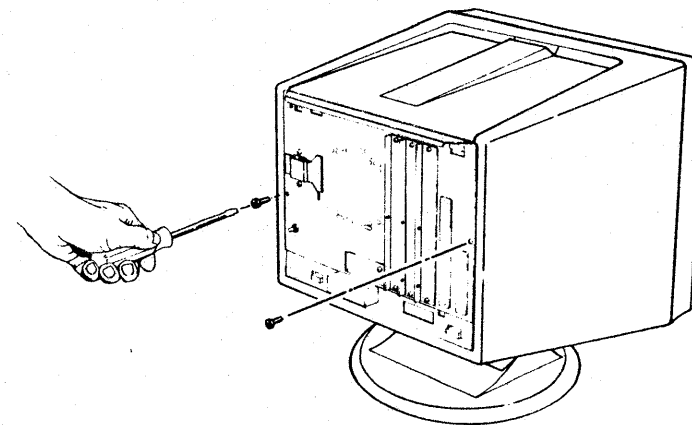

- 7** Remove the two screws that hold the access cover in place and remove the access cover. Save the screws. (If the access cover does not lift off easily, gently press down on the cover to release the internal catch.)

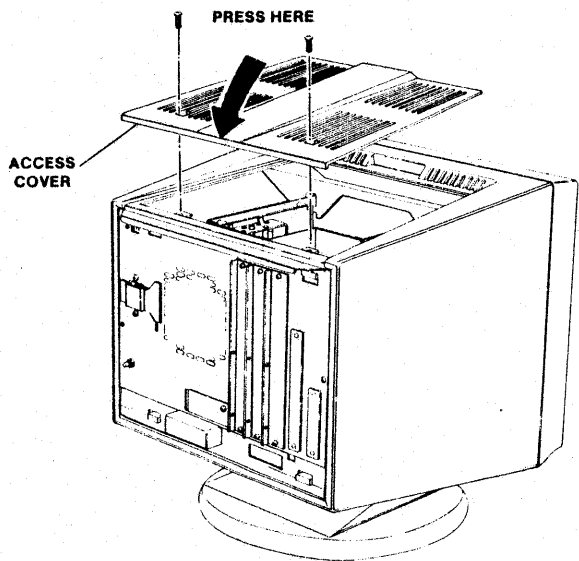

- 8** Give the drawer an initial hard pull to loosen it. Then carefully slide out the drawer assembly. (Be sure to support the drawer assembly as you slide it out of the terminal.) Set the drawer on a work table with the back of the drawer assembly facing away from you.

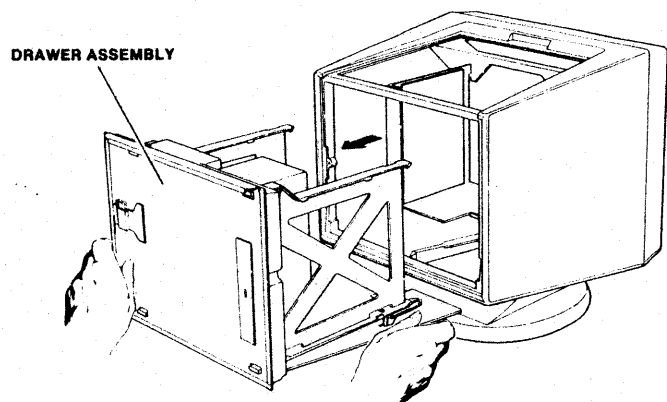

- 9** Remove the cable retainer. Next, remove the graphics board from its conductive envelope. Save the envelope for possible future use. Then locate the printed-circuit board holder. The graphics board slides in on the left-hand side of the board holder. Look at the graphics board. It has two connectors grouped together on the board. It also has a single connector. When you insert the graphics board, the connectors should face away from the inside of the drawer.

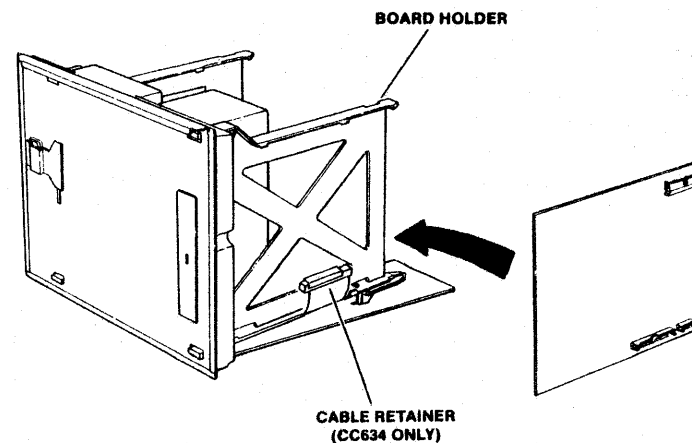

- 10** Carefully lift up on the catch and insert the graphics board in the printed-circuit board holder. Release the catch and slide the board in until the catch snaps over the end of the board. Check that the board is locked in place and secured by the catch.

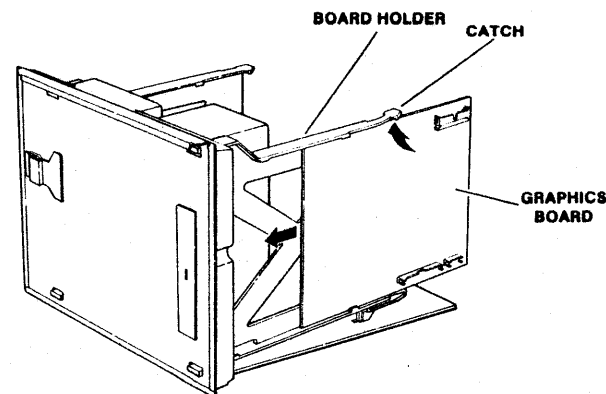

- 11** Locate the two connectors grouped together on the graphics board. Locate the cable connector attached to a flat cable that runs under the board holder. Plug the cable connector onto the larger board connector. Plug the interconnect cable onto the connector on the main logic board. Then plug the cable onto the smaller board connector.

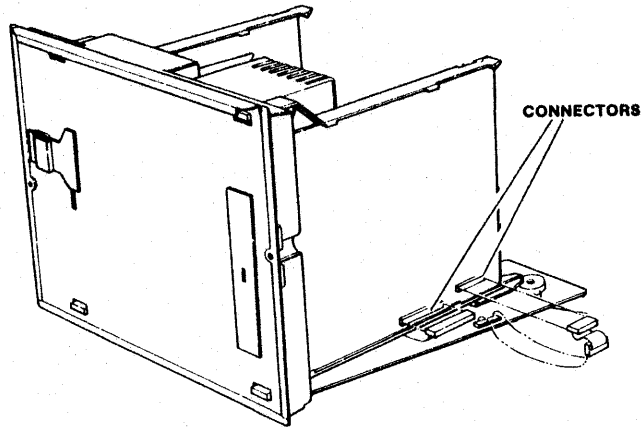

- 12** Locate the plastic graphics-board jumper on the main logic board. Unplug the jumper. Then plug it in so that it is in the GRAPHICS position.

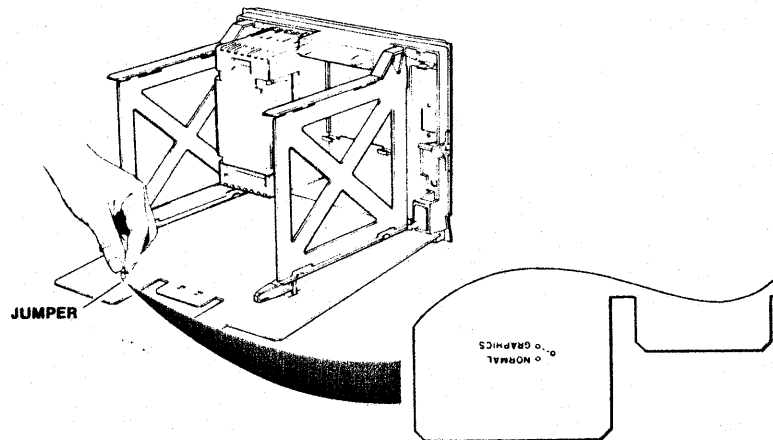

NOTE: If you are installing the internal modem at the same time as the graphics board, turn back to the internal modem installation procedure and complete step 14 and the following steps.

- 13** Locate the center drawer slide. When you start to put the drawer assembly back into the terminal, this drawer slide aligns with a guide on the underside of the drawer assembly.

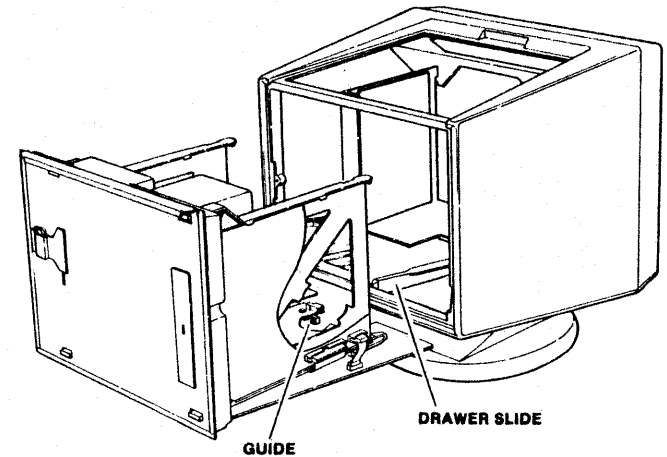

- 14** Pick up the drawer and carefully insert it back into the terminal. As you insert the drawer, be aware of the wires on the left side of the drawer assembly. These wires can be snagged, so guide them with your hand if necessary. Hold the terminal and give the drawer a final push to seat it.

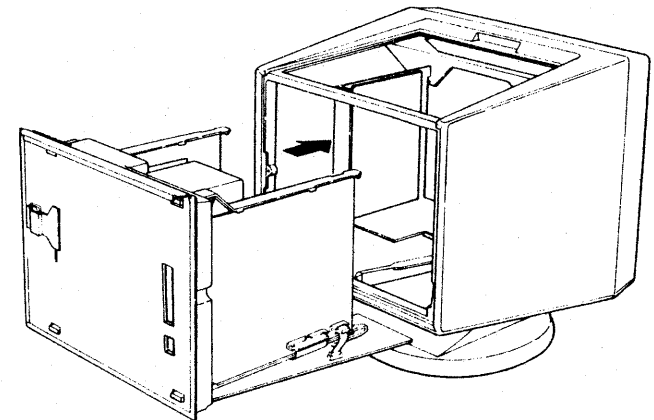

- 15** Replace the access cover and the two access-cover screws. Push down the latch that holds the access cover in place. Replace the two screws on the back of the terminal.

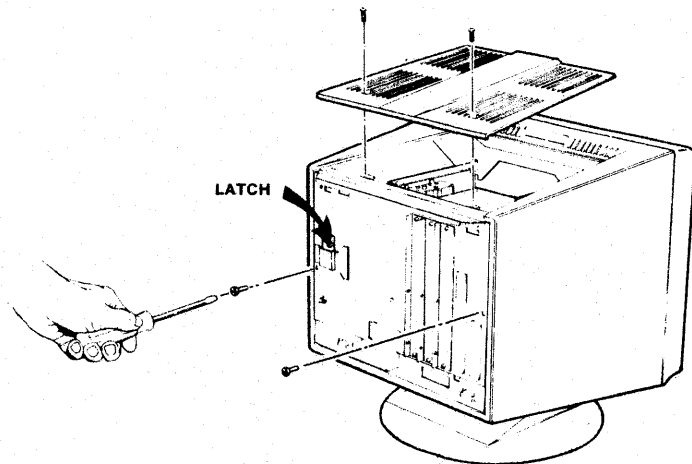

- 16** Record the following information on the equipment configuration log on the back of the terminal:

- Equipment identification number: XA368
- Series code: last two characters in the EQUIPMENT box on the green tag (in the plastic envelope attached to the carton)
- Serial number: characters in the SERIAL NO. box on the green tag.
- Date of installation and your name

EQUIPMENT CONFIGURATION LOG			
CONTROL DATA		BASE EQUIP ID NO.	S/N
EQUIP ID NO.	SERIAL NO.	*CHANGE NO.	DATE AND INSTALLED BY

AA7911-1 Rev. 3-82 EQUIPMENT COPY *KEY FOR CHANGE NO. PREFIXES
 F = FCG E = ECO D = A-DEVIATION

EQUIPMENT IDENTIFICATION NUMBER AND SERIES CODE

SERIAL NUMBER

DATE OF INSTALLATION AND YOUR NAME

- 17** Lay the terminal on its right side so the left side is facing up. Then plug the cable from the keyboard into the connector on the bottom of the terminal. Note that the plastic clip on the plug points toward the front of the terminal.

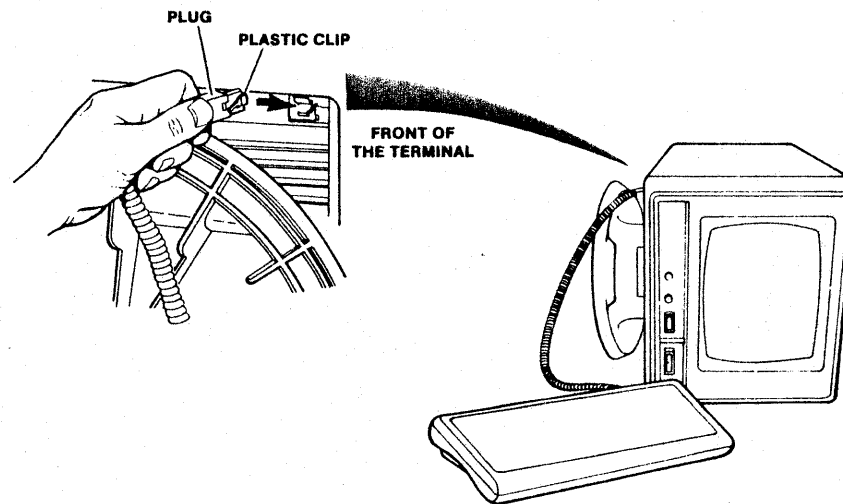

- 18** Place the terminal in an upright position. Connect any cables removed in step 3. Connect the power cord to the back of the terminal and press the power cord into the cable retainer on the latch. Connect the power cord from the terminal to the electrical outlet.

Checkout

You have completed the physical installation of the graphics board. Follow these steps to check that the board is working properly:

- 1** Turn on the terminal by pressing the side of the POWER switch marked with a 1.

2 The Mode Selection display appears on the screen. If you do not see the Mode Selection display:

a Pull out the TEST switch at the back of the terminal.

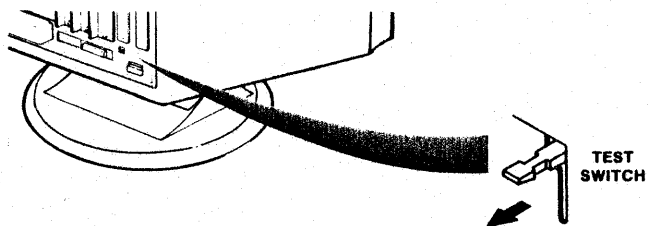

b Press the RESET switch at the front of the terminal.

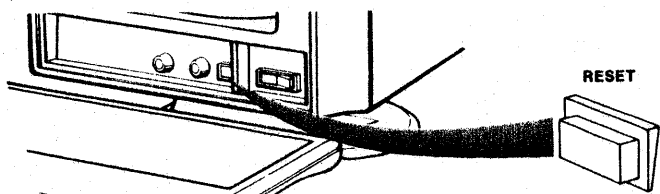

c Disregard the TEST SWITCH ENABLED message that appears with the Mode Selection display. Push in the TEST switch.

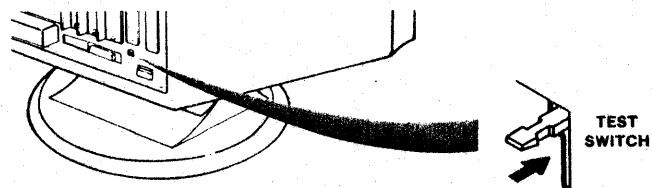

3 With the Mode Selection display on the screen, press and hold the CTRL (control) key while you press the SETUP key.

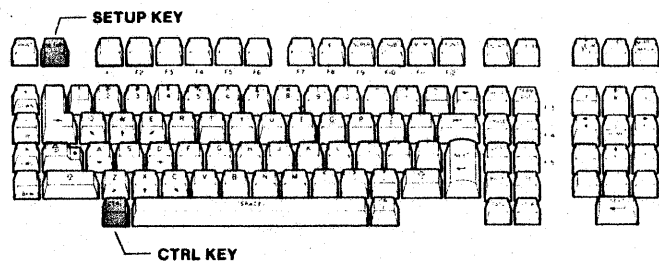

4 Press the F3 key and then press the space bar twice to space to position 3 of the F3 block.

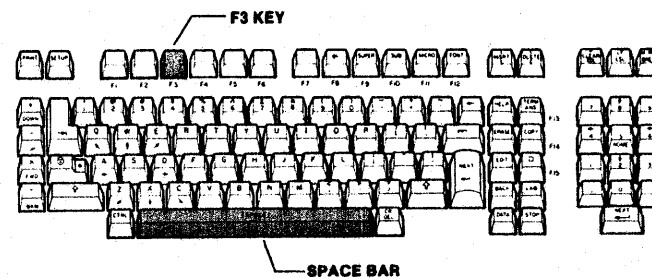

5 Type a 1 in position 3 of the F3 block.

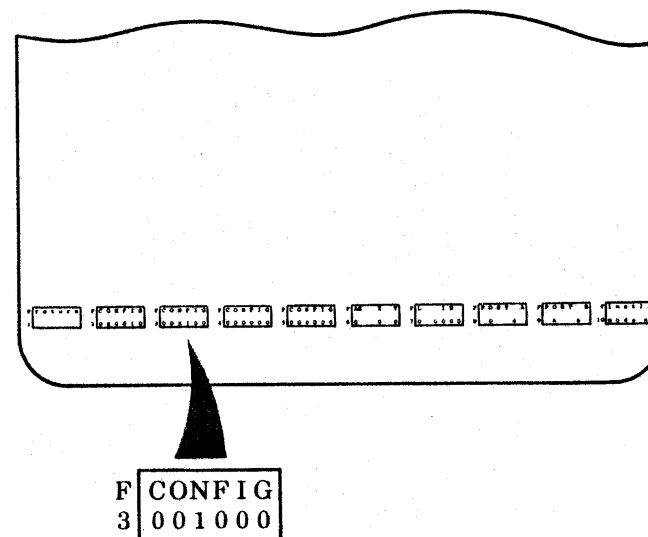

- 6 Press the COPY key.

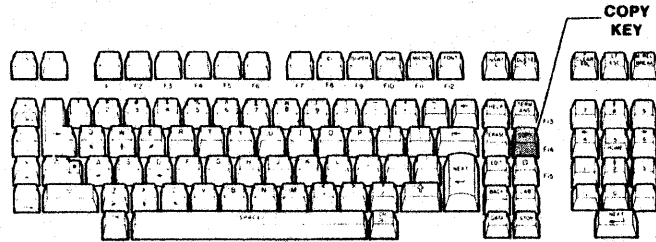

- 7 Press RESET to run the terminal self test. If a GRAPHICS FAIL message appears, remove the drawer assembly again and recheck all connections.

CAUTION: If the graphics board is removed from the terminal, the board must be inserted into its conductive envelope.

If the message appears again, go to **HELP 100** in the Problem Solving Guide.

NOTE: If the graphics board is the only item you are installing, turn to the Installation Record at the end of this section to record the installation of the graphics board.

NOTE: If you have also installed an internal modem, turn to the Installation Record at the end of this section to record the installation of the graphics board and modem. Then turn to the Cable Connection section to connect the modem to the telephone lines, and to Additional Parameters in the Parameter Settings section to set the parameters associated with the internal modem.

Parallel-Interface Board (YR102)

The terminal uses the parallel-interface board to “talk” to devices, such as a flexible-disk drive or a parallel-interface printer.

You will need a small Phillips-head screwdriver to install the board.

- 1 Turn the terminal off.
- 2 Unpack the item that has YR102 (as the first five characters in the EQUIPMENT box) on the green tag in the attached plastic envelope. You will find a printed-circuit board, stamped PARALLEL INTERFACE. It looks like this:

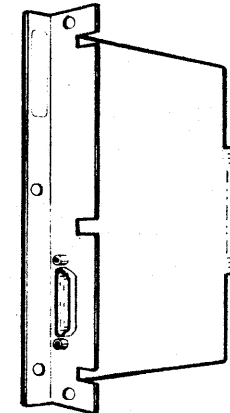

- 3** At the back of the terminal, locate the cover plate for the I/F-1 board slot.

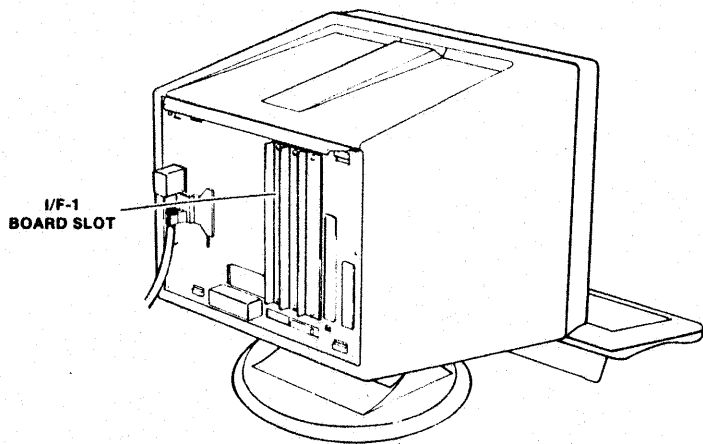

- 4** Remove the two screws and the cover plate at I/F-1. This exposes the I/F-1 board slot. Save the cover plate for possible repacking of the terminal. Save the screws; you will need them in step 6.

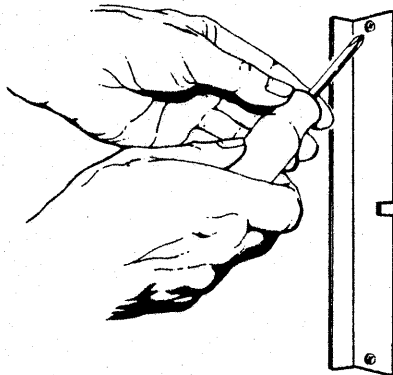

- 5** Guide the parallel-interface board carefully into the I/F-1 board slot. The board should slide in easily except for the last 1/4 inch. To seat the board the last 1/4 inch, you have to press hard.

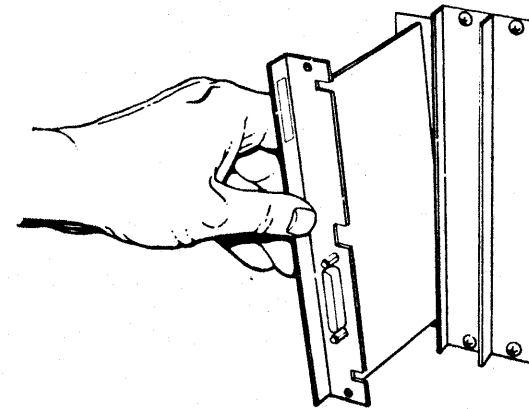

- 6** Attach the cover plate of the parallel-interface board to the terminal with the two screws you removed in step 4.

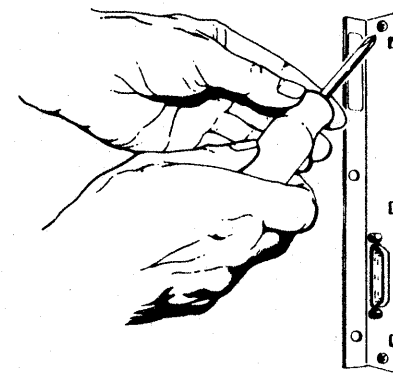

You have completed the physical installation of the parallel-interface board.

NOTE: If the parallel-interface board is the only item you are installing, turn to the Installation Record on the last page of this section to record the installation of the parallel-interface board. Then turn to the Cable Connection section to connect a device to the parallel-interface board, and to the procedure in the Parameter Settings section to set the parameters associated with the parallel-interface board and the connected device.

Serial-Interface Board (YR101)

In this manual, we call this board a serial-interface board although the board is stamped Dual Asynchronous Interface. The terminal uses this board to “talk” to a serial device, such as a serial-interface printer.

You will need a small Phillips-head screwdriver to install the board.

- 1 Turn the terminal off.
- 2 Unpack the item that has YR101 (as the first five characters in the EQUIPMENT box) on the green tag in the attached plastic envelope. You will find a printed-circuit board stamped DUAL ASYNCHRONOUS INTERFACE. It looks like this:

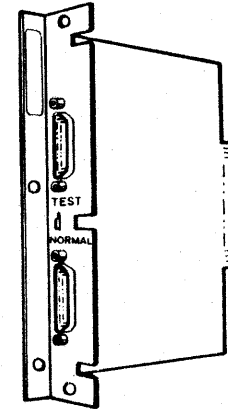

- 3** At the back of the terminal, locate the cover plate for the I/F-2 board slot. Remove the two screws and the cover plate at I/F-2. This exposes the I/F-2 board slot. Save the cover plate for possible repacking of the terminal. Save the screws: you will need them in step 5.

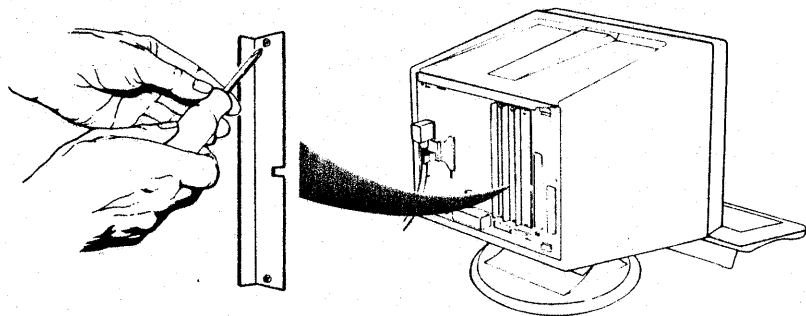

- 4** Guide the serial-interface board carefully into the I/F-2 board slot. The board should slide in easily except for the last 1/4 inch. To seat the board the last 1/4 inch, you have to press hard.

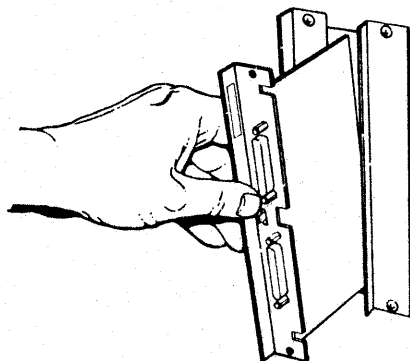

- 5** Attach the cover plate of the serial-interface board to the terminal with the two screws you removed in step 3.

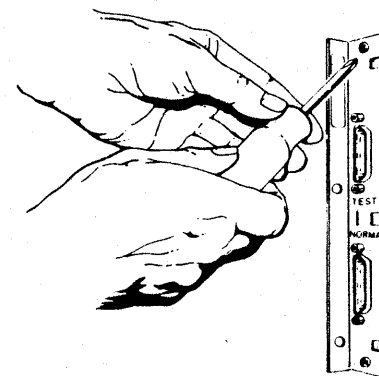

- 6** The serial-interface board has a TEST/NORMAL switch. Push the TEST/NORMAL switch down to the NORMAL position.

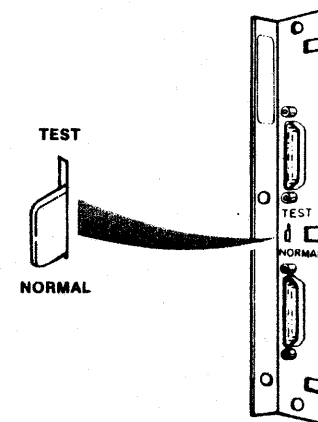

You have completed the physical installation of the serial-interface board.

NOTE: If the serial-interface board is the only item you are installing, turn to the Installation Record on the last page of this section to record the installation of the serial-interface board. Then turn to the Cable Connection section to connect a device to the serial-interface board, and to the procedure in the Parameter Settings section to set the parameters associated with the serial-interface board and the connected device.

401X Graphics Memory Module (YR104)

The terminal uses a memory module as one way of loading a program into the terminal's memory.

You will need a small Phillips-head screwdriver to install the memory module.

- 1 Turn the terminal off.
- 2 Unpack the item that has YR104 (as the first five characters in the EQUIPMENT box) on the green tag in the attached plastic envelope. You will find a memory module that looks like this:

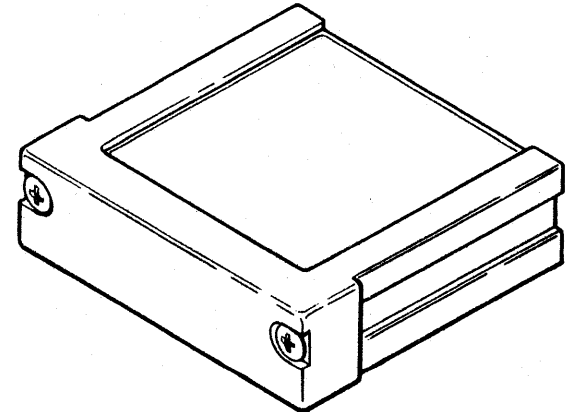

- 3** At the back of the terminal, locate the memory module cover plate. Remove the screw and the cover plate. This exposes the memory module connector.

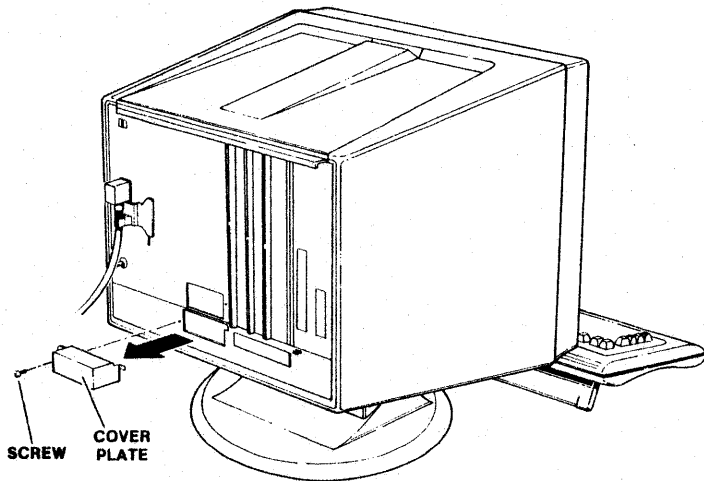

- 4** Carefully insert the module (label side up) in the exposed connector. If the module does not slide in easily, do not push hard. Move the module up and down to align the pins with the module connector.

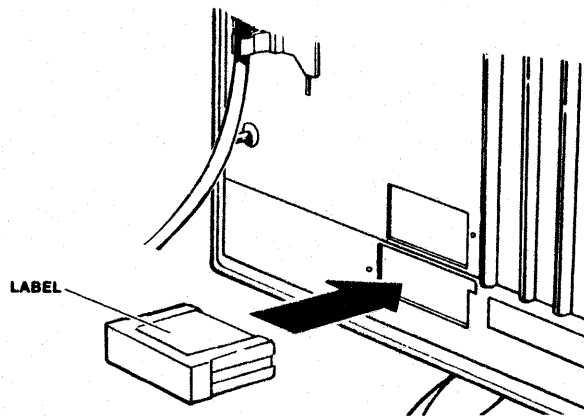

- 5** Reattach the cover plate with the screw you removed in step 4.

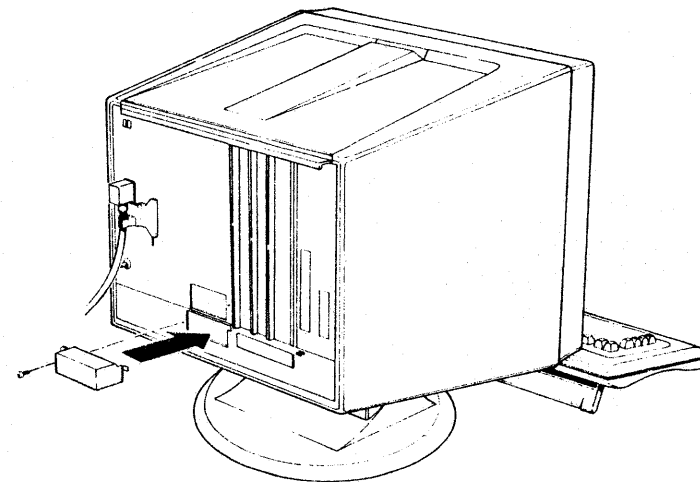

You have completed the physical installation of the memory module.

NOTE: If the memory module is the only item you are installing, turn to the Installation Record to record the installation of the memory module. See your memory module manual for information on memory module parameters and operation.

Keycap Kit (YA274)

The terminal is shipped with a standard keyboard already installed. Additional keycap kits are available from Control Data for the following character sets:

- French
- German
- Swedish/Finnish
- United Kingdom
- Spanish
- Danish/Norwegian

To install any of the keycap kits, follow the Installation Instructions packed with the kit.

NOTE: If the keycap kit is the only item you are installing, turn to the Installation Record at the end of this section to record the installation of the keycap kit. Then turn to the procedure in the Parameter Settings section to set the parameter associated with the keycap kit.

Installation Record

These pages are used to keep a record of the additional items installed with your display terminal. Check each item that you have installed.

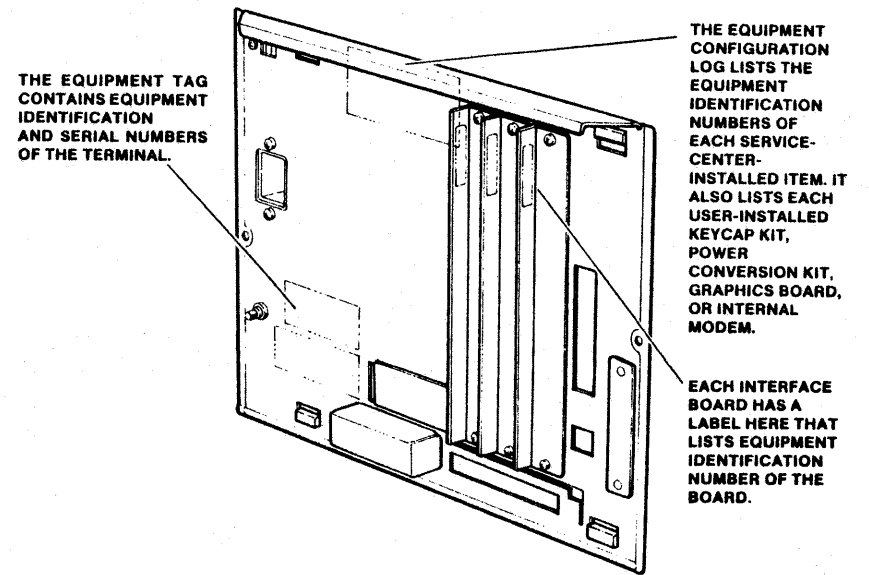

The serial number of the terminal is _____
and its Equipment Identification number is:

_____ CC634-B

_____ CC638-B with a touchpanel and graphics board installed at the factory

Service-Center installed items include:

_____ XA358-A touchpanel and graphics board

User-installed items include:

- _____ YA275-A power conversion kit
- _____ XA360-A 1200/1200-baud internal modem
- _____ XA368-A graphics board
- _____ YR102-A parallel-interface board
- _____ YR101-A serial-interface board
- _____ YA274-A United Kingdom keycap kit
- _____ YA274-B Spanish keycap kit
- _____ YA274-C German keycap kit
- _____ YA274-D French keycap kit
- _____ YA274-E Swedish/Finnish keycap kit
- _____ YA274-F Danish/Norwegian keycap kit
- _____ YR-104 401X graphics memory module

CONTINUE WITH THE NEXT SECTION.

This section shows you how to connect:

- A 1200/1200-baud internal modem
- An external modem
- A local computer
- A serial-interface (dual-asynchronous) device
- A parallel-interface device

Skip any instructions that do not apply.

Connectors

This illustration highlights the connectors on the back of the terminal:

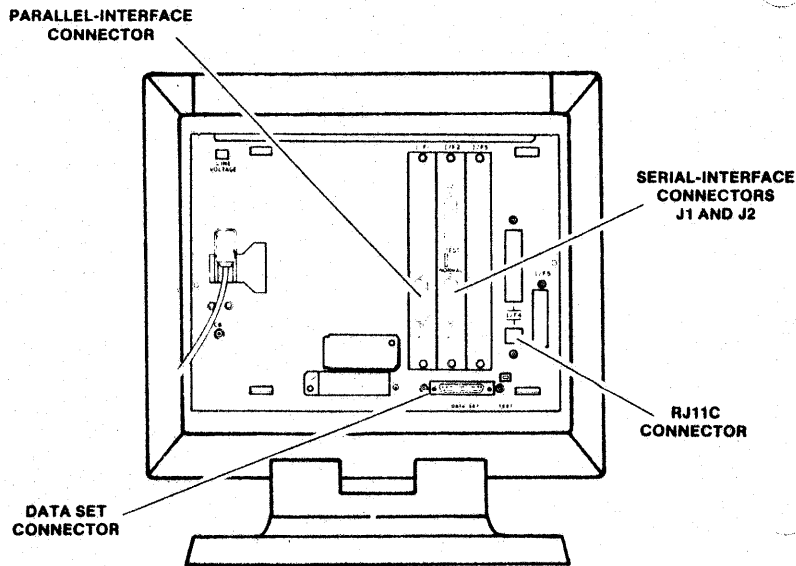

NOTE: Tighten all connector screws when attaching cables to connectors.

1200/1200-Baud Internal Modem

Before connecting the 1200/1200-baud internal modem to the telephone lines, you must provide the telephone company with:

- Your telephone number
- The modem FCC registration number
- The ringer equivalence number
- The type of phone jack used (RJ11C)

You can find the second and third of the preceding items on the label attached to the modem (at the I/F-4 location at the back of the terminal).

NOTE: To contact the telephone company, look in the front pages of your telephone book for the Business Service telephone number.

To connect a terminal with an internal modem to the telephone lines, you need:

- A 4.3-m (14-ft) telephone-line extension cord with an RJ11-type modular plug on one end and a duplex adapter on the other end (provided with the modem).
- An RJ11C phone jack within 4.3 m (14 ft) of the terminal.

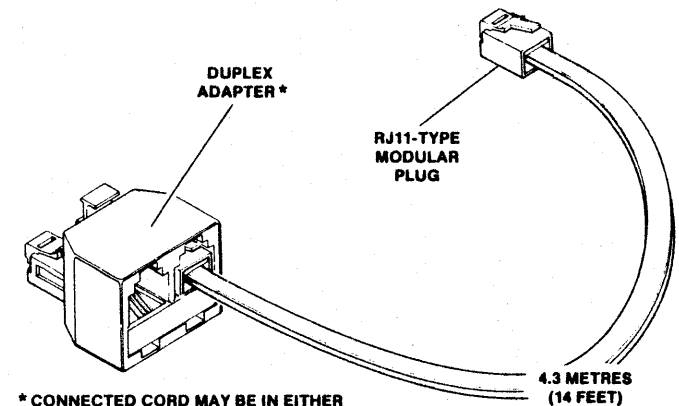

* CONNECTED CORD MAY BE IN EITHER OPENING OF THIS ADAPTER

NOTE: In areas under the Canadian Department of Communications guidelines, the RJ11-type modular plugs on the ends of the telephone-line extension cord have had their plastic retaining clips slightly shortened. In addition:

- The T-adapter (duplex adapter) is used when an additional terminal or a telephone is required.
- The T-adapter must be installed at the telephone-company jack and not at the modem jack.
- The cable end with the certification label must be plugged into modem jack.

Follow these steps to connect a terminal equipped with an internal modem to the telephone lines:

- 1** Unplug the telephone cord from the wall jack by squeezing the plastic clip of the RJ11-type modular plug and pulling the plug out.

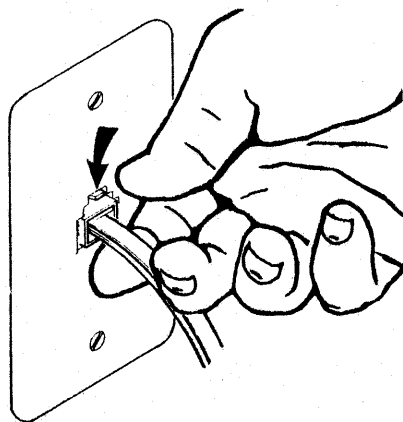

- 2** Insert the plug on the duplex adapter (on one end of the telephone-line extension cord) into the wall jack.

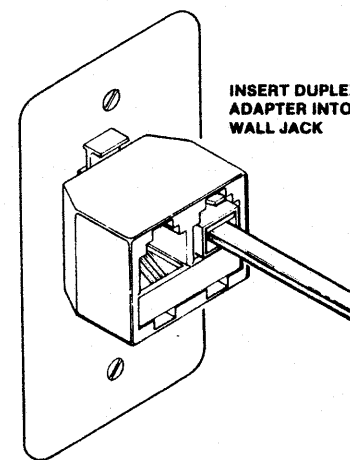

- 3** Insert the single RJ11-type modular plug (on the other end of the telephone-line extension cord) into the RJ11C connector at the back of the terminal.

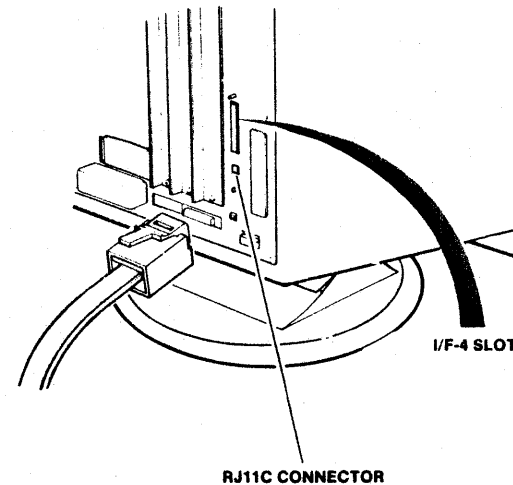

- 4 Insert the telephone cord (removed in step 1) into the duplex adapter plugged into the wall jack.

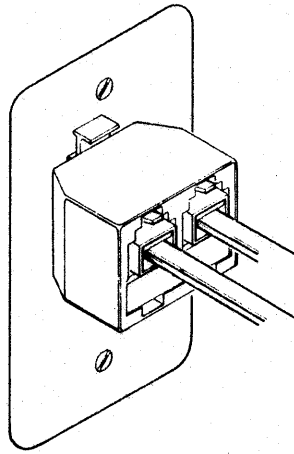

- 5 Check that your connections are similar to the following.

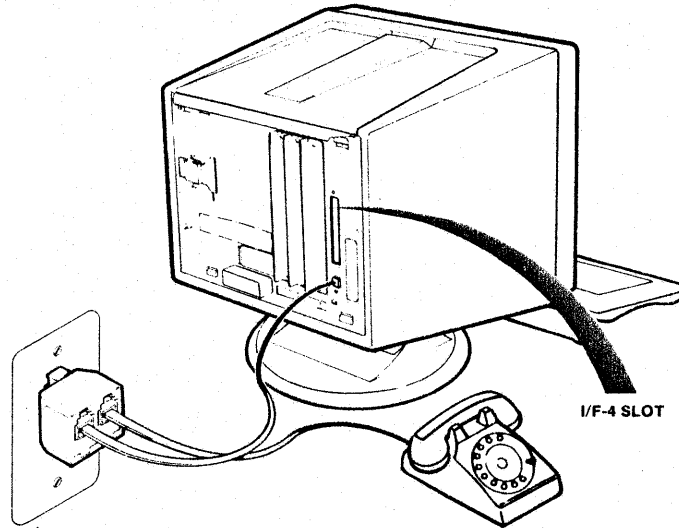

NOTE: If the internal modem is the only item you are connecting to the terminal, turn to Additional Parameters in the Parameter Settings section to set the parameters associated with the internal modem.

External Modem

External modems that may be connected to the terminal are available from many manufacturers. This heading gives installation instructions for the following external modems:

- Universal Data Systems (UDS) 212LP
- Racal-Vadic VA3451
- Bell 212A
- Multi-Tech MT212A

If your modem is not on the list, consult the modem manual for installation and operation procedures.

You will need a slot-head screwdriver and an installed telephone.

Before connecting an external modem to the telephone lines, you must provide the telephone company with:

- Your telephone number
- The FCC registration number that appears on a tag on the modem.
- The ringer equivalence number that appears on a tag on the modem.
- The type of phone jack (RJ11C) or modem used.

NOTE: To contact the telephone company, look in the front pages of your telephone book for the Business Service telephone number.

A communications cable (equipment number YA255), separately ordered and packaged, is available from Control Data. Use this cable or an equivalent RS-232-C cable to connect an external modem to the terminal DATA SET connector.

The following instructions apply to all external modems:

- 1** Turn off the terminal.
- 2** Plug either end of the YA255 cable into the DATA SET connector in the lower-right corner at the back of the terminal.

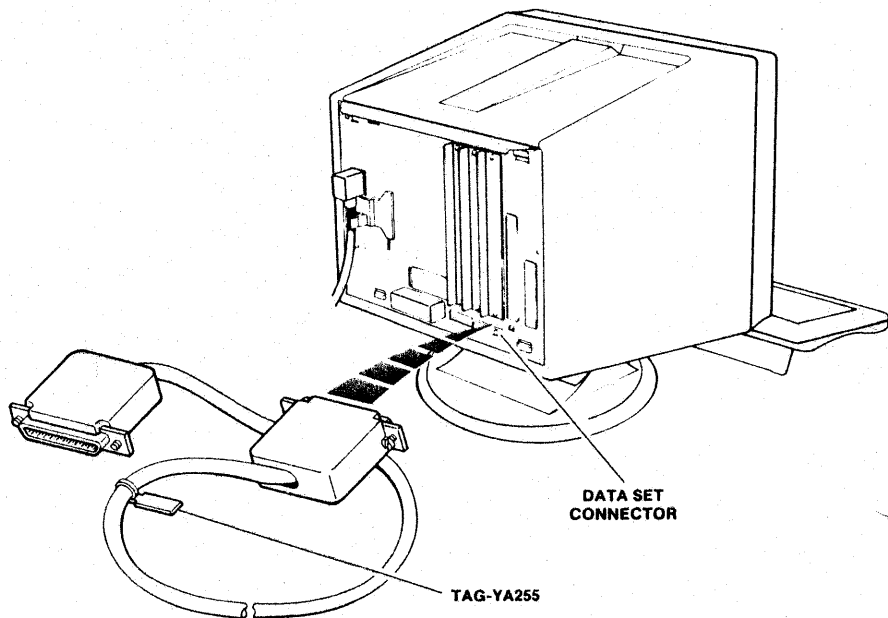

- 3** Connect the opposite end of the cable to the DTE/RS232C interface connector at the back of the modem.
- 4** Use a small slot-head screwdriver to tighten the screws on each side of the connector.

When you have completed these steps, go to step 1 for the type of modem you are installing.

Universal Data Systems (UDS) 212LP Modem

- 1** Set the DATA/TALK switch to TALK.

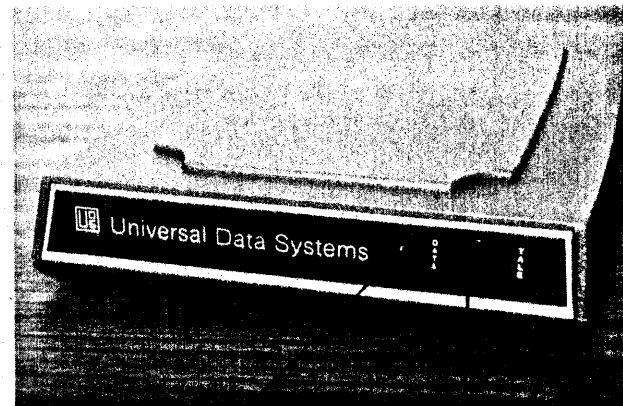

RED CARRIER LIGHT DATA/TALK SWITCH

- 2** Switch the ORG/ANS switch to the ORG position.

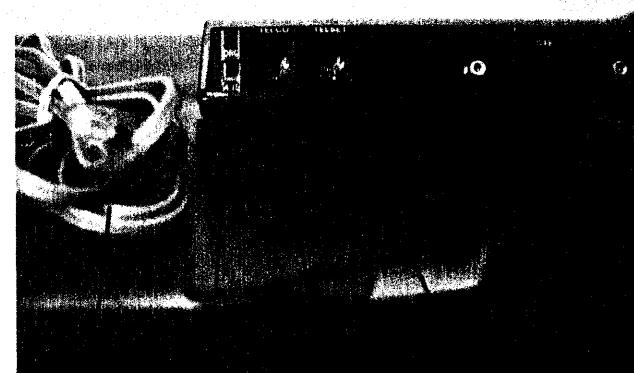

SPECIAL CABLE TELCO JACK TELSET JACK
ORG/ANS (ORIGINATE/ANSWER) SWITCH DTE (DATA TERMINAL EQUIPMENT)

- 3** Disconnect the telephone cord at the back of the telephone and connect it to the TELCO jack on the back of the modem.
- 4** Connect the second telephone cord provided with the modem to the telephone and to the TELSET jack on the back of the modem.

NOTE: If you do not use the telephone cord provided by the manufacturer, you may not be able to dial out using a Touch-Tone* phone.

NOTE: If an external modem is the only item you are connecting to the terminal, turn to Additional Parameters in the Parameter Settings section to set the parameters associated with the external modem.

Racal-Vadic VA3451 Modem

- 1** Connect the power supply box to the electrical outlet.
- 2** Unplug the telephone cord from the back of the telephone.
- 3** Plug the two-to-one adapter into the modular jack at the back of the telephone.
- 4** Connect the telephone cord to the adapter.
- 5** Connect the preconnected telephone cord on the modem to the adapter.
- 6** Verify that the left-rear switch is in the middle and that the right-rear switch is in the leftmost position.



FA (FORCE ANSWER)
 HS (HIGH-SPEED)
 DA/VO (DATA VOICE)
 TXD (TRANSMIT DATA)
 RXD (RECEIVE DATA)
 HS (HIGH-SPEED)

CXR (CARRIER DETECT)
 RI (RING INDICATOR)
 DTR (DATA TERMINAL READY)
 DSR (DATA SET READY)
 CTS (CLEAR TO SEND)

*Registered trademark of American Telephone and Telegraph

- 7 Set HS switch to HS.
- 8 Set DA/VO switch to VO.

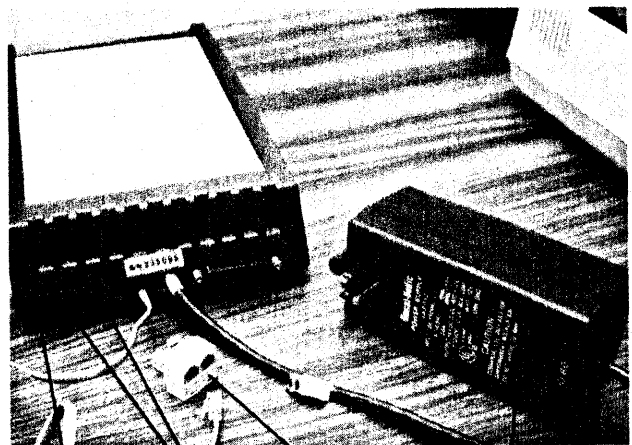

DTE CONNECTOR
 BLACK POWER SUPPLY BOX
 RIGHT AND LEFT SLIDE SWITCHES
 TWO-TO-ONE MODULAR PLUG ADAPTER (SE 267A)

NOTE: If an external modem is the only item you are connecting to the terminal, turn to Additional Parameters in the Parameter Settings section to set the parameters associated with the external modem.

Bell 212A Dataphone Modem

- 1 Turn on the terminal.
- 2 Check to see that the MC and TR lights are on. If the MC light is not on, you should check to be sure that the terminal is plugged in and that the cable connecting the terminal to the modem is secure. If the MC light remains off, call your local telephone company.



AL (ANALOG LOOPBACK CIRCUIT)
 ST (SELF TEST)
 RDL (REMOTE DIGITAL LOOPBACK)
 DL (DIGITAL LOOPBACK)
 HS (HIGH-SPEED)

NOTE: If an external modem is the only item you are connecting to the terminal, turn to Additional Parameters in the Parameter Settings section to set the parameters associated with the external modem.

Multi-Tech MT 212A Modem

- 1 Plug the power cord into an electrical outlet.
- 2 Set the 1200/300 switch to 1200.
- 3 Push the OOS/ANLB switch to the left.

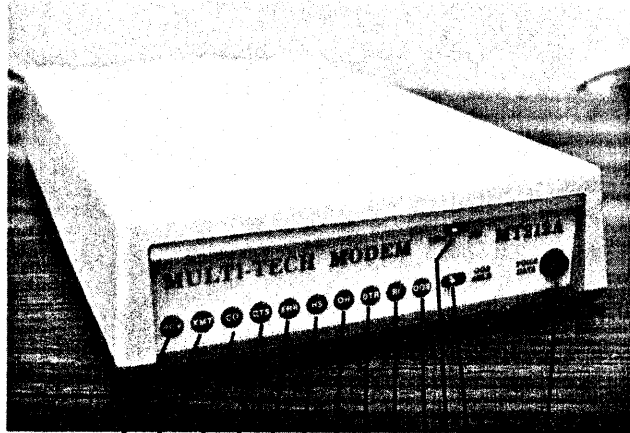

RCV (RECEIVE)
 XMT (TRANSMIT)
 CO (CARRIER ON)
 CTS (CLEAR TO SEND)
 ERR (ERROR)
 HS (HIGH-SPEED)
 OH (OFF HOOK)
 DTR (DATA TERMINAL READY)
 RI (RING INDICATOR)
 OOS (OUT OF SERVICE)
 1200/300
 OOS/ANLB (OUT OF SERVICE/ANALOG LOOPBACK)
 VOICE DATA

- 4 Unplug the telephone cord from the wall and plug it into the TELSET jack.
- 5 Connect one end of the telephone cord that came with the modem to the DATACOMM LINE connector and the other end to the wall jack.

NOTE: The CO, HS, and DTR lights should be lit. If they are not, check to see that the power light is on.

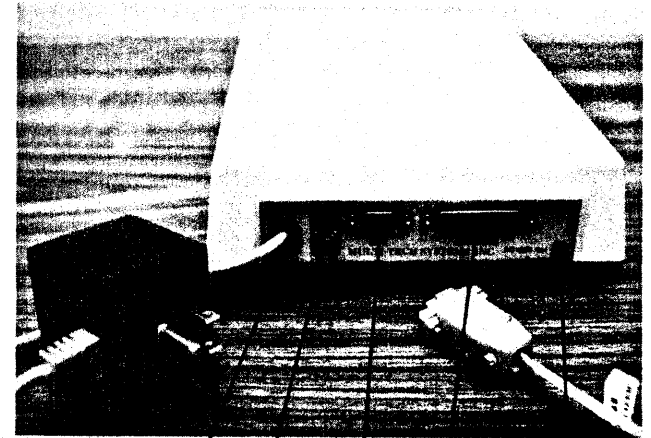

POWER CORD
 TELSET JACK
 DATACOMM JACK
 POWER-ON LIGHT
 EIA RS232C INTERFACE

NOTE: If an external modem is the only item you are connecting to the terminal, turn to Additional Parameters in the Parameter Settings section to set the parameters associated with the external modem.

Local Computer

A communications cable (equipment number YA255), separately ordered and packaged, is available from Control Data. Use this cable or an equivalent RS-232-C cable to connect a local computer to the terminal DATA SET connector.

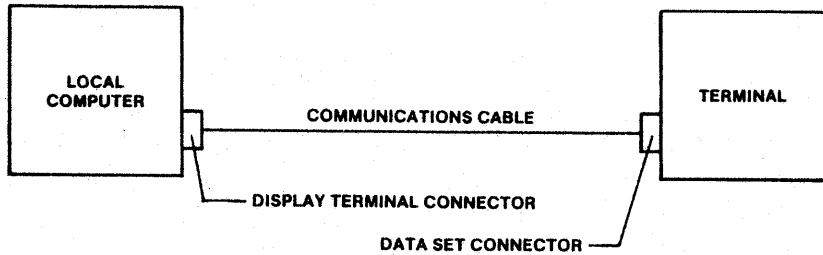

Serial-Interface Device

The following illustration shows you how to connect a serial-interface device to your terminal. Be sure to tighten all connector screws when attaching cables to connectors.

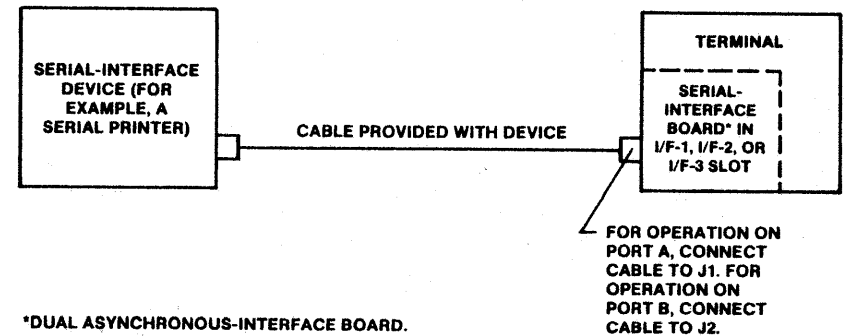

Parallel-Interface Device

The following illustration shows you how to connect a parallel-interface device to your terminal. Be sure to tighten all connector screws when attaching cables to connectors.

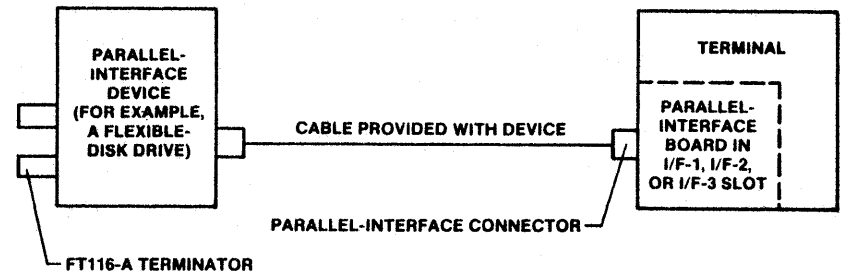

Introduction

This section shows you how to display and change the terminal's preset parameters so that the terminal will operate properly with your application. If you have installed any additional items, you may need to modify the preset parameters.

Information helpful in making parameter changes may also be found in your application manuals and in the literature that may come with additional items you have installed.

What are Parameters?

Parameters are information the terminal needs to know to operate properly. They act as guidelines for the terminal.

Examples are:

- Does your terminal have a graphics printer connected?
- Does your terminal have a serial-interface board installed?
- Does your terminal have a flexible-disk drive connected?

The terminal's parameters are preset for an average system. These preset parameters are called default parameters. Parameters are changed when:

- Your requirements change
- You add additional items to your terminal
- You use certain application programs (these changes will be identified in the application program manuals)

There are three groups of parameters:

- Terminal installation parameters which tell the terminal what additional items are installed with the terminal
- Mode installation parameters which determine how a mode will operate
- Operator parameters which let the operator temporarily change certain operating guidelines

NOTE: The following pages cover terminal and mode installation parameters. Operator parameters are covered in the Operating Guide section of this manual.

Both terminal and mode installation parameters are stored in the terminal's non-volatile memory (NVM). NVM is the memory that stays active even when the terminal is turned off or unplugged. A battery, already installed in the back of the terminal, keeps the memory active.

You are now going to display default parameters stored in this memory and, if necessary, enter new parameters.

NOTE: If your terminal is part of a CDC 110 Microcomputer System using CP/M*, parameters may be changed by using the TERMSET program on the CP/M disk. While the CP/M disk is being used, these changes override any changes made using the following method. See your CP/M manual for more information.

Setting Terminal Installation Parameters

- 1 Turn on the terminal. The Mode Selection display appears on the screen:

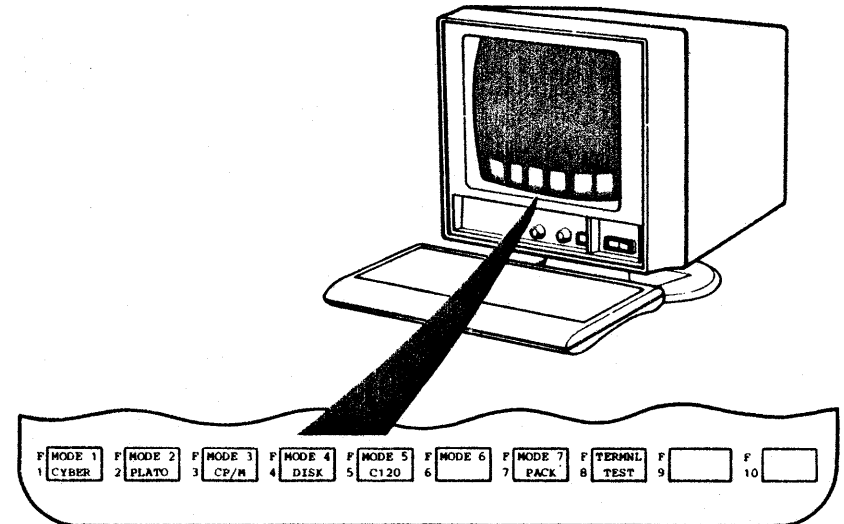

*Registered trademark of Digital Research, Inc.

- 2 Press and hold the CTRL key while you press the SETUP key.

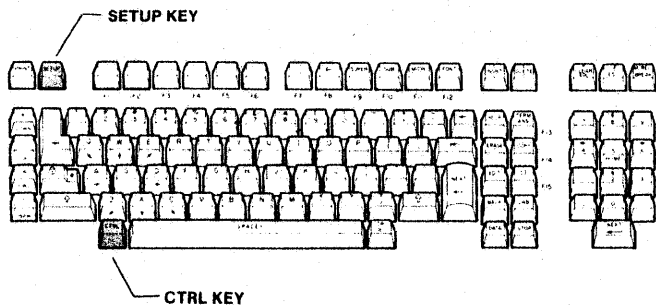

- 3 The default terminal installation parameters appear in a row of lighted blocks on the screen:

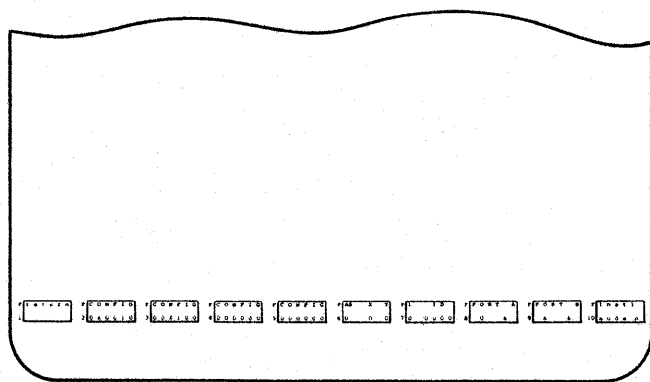

NOTE: Where an X is shown in the illustration, on the screen you will see a 0 if you have a CC634 terminal, or a 1 if you have a CC638 terminal.

- 4 To the left of each lighted block is the letter F with a number below it. This number relates the block to the F key with the same number.

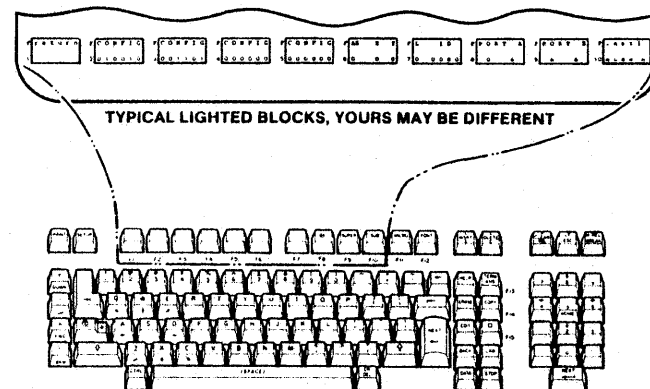

A small blinking light appears in the F2 block. This light is a cursor. The cursor shows you where the next character you type on the keyboard will appear on the screen.

F	C	O	N	F	I	G
2	0	X	0	0	0	0

NOTE: Only certain keys work when changing parameters. Pressing a key that does not work will simply sound the alarm (a beep). The cursor may be moved forward with the space bar or backward with the backspace key (←). Pressing an F key will move the cursor to the first position of the block with the same F number as the key. Do not press the F1 or F10 key at this time. (If you did, just press RESET and start over.)

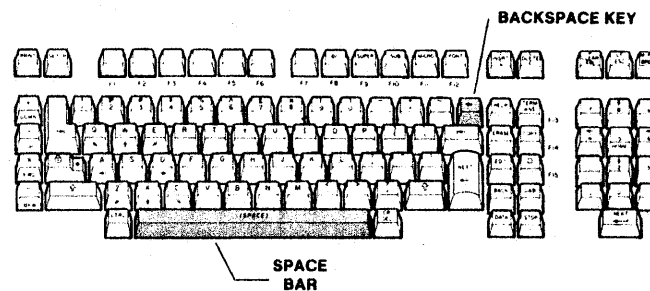

- 5** The cursor appears in the first character position of the F2 lighted block. You do not have to enter anything in the first position of the F2 block, so press the space bar. The cursor then moves to the second position.

F	C	O	N	F	I	G
2	0	X	0	0	0	0

- 6** You do not need to enter anything in the second position, so press the space bar again. The cursor then moves to the third position.

F	C	O	N	F	I	G
2	0	X	0	0	0	0

- 7** If you have installed a serial-interface board (YR101) at I/F-2 on the back of the terminal, enter a number 1 in the third position. You may use the number keys in the second row from the top of the keyboard or the number keys in the numeric pad on the right side of the keyboard. If you did not install a serial-interface board, press the space bar.

F	C	O	N	F	I	G
2	0	X	0	0	0	0

1 for serial-interface board

- 8** If you have a parallel graphics printer, enter the number 1 in the fourth position. If you did not install a parallel graphics printer, press the space bar.

F	C	O	N	F	I	G
2	0	X	0	0	0	0

1 for parallel graphics printer

1 for serial-interface board

- 9** If you have installed a flexible-disk drive, enter a 1 in the fifth position. If you did not install a flexible-disk drive, press the space bar.

F	C	O	N	F	I	G
2	0	X	0	0	0	0

1 for flexible-disk drive

1 for parallel graphics printer

1 for serial-interface board

- 10** When the cursor moves to the sixth position, if you have a serial graphics printer, enter a 1. If you do not have a serial graphics printer, press the space bar.

F	C	O	N	F	I	G
2	0	X	0	0	0	0

1 for serial graphics printer

1 for flexible-disk drive

1 for parallel graphics printer

1 for serial-interface board

- 11** The cursor then moves to the first position of the F3 block. A 1 should be in this position only if an internal modem is installed in the terminal. (You entered a 1 when you installed and tested the internal modem.) Press the space bar twice. The cursor then moves to the third position.

F	C	O	N	F	I	G
3	0	0	X	0	0	0

1 for internal modem

- 12** If you installed a graphics board or have a CC638 terminal, a 1 should be in the third position of the F3 block. (You entered a 1 when you installed and tested the graphics board.) Press the space bar.

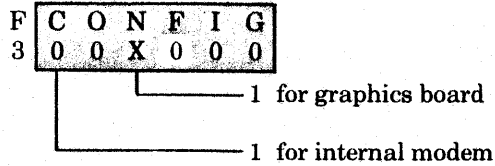

- 13** If you have installed a parallel-interface board (YR102) at I/F-1 on the back of the terminal, enter a 1 in the fourth position. If you did not install a parallel-interface board, press the space bar.

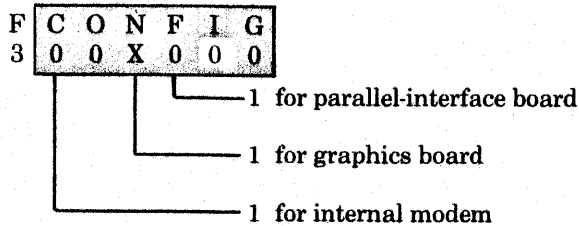

- 14** Press the F4 key. Then space to the third position of the F4 block. If you have an internal modem, enter a 0. (You entered a 1 when you installed and tested the internal modem.) A 0 tells the modem not to run its 14-second long loopback test when the terminal is turned on or reset. If you do not have an internal modem, press the space bar.

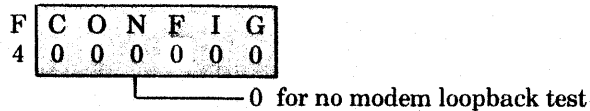

- 15** If you have an internal modem and it will use tone dialing, enter a 1 in the fourth position of the F4 block. If the modem will use pulse dialing, or you do not have a modem, press the space bar. (If you are not sure, call your telephone company to find out whether your telephone line uses tone dialing or pulse dialing.)

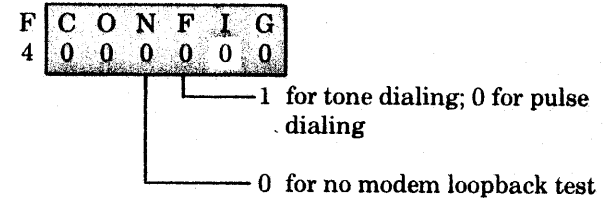

- 16** Press the F7 key. If you did not install a keycap kit, go on to the next step. If you installed a keycap kit, characters displayed on the screen are to be:

- French: enter a 2
- German: enter a 3
- Swedish/Finnish: enter a 4
- United Kingdom: enter a 5
- Spanish: enter a 6
- Danish/Norwegian: enter a 7

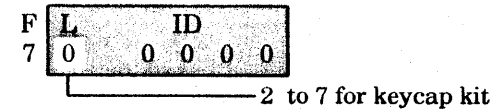

- 17** Press the F8 key.

- 18** If you have a serial printer (connected to the serial-interface board), enter a 5 in the first position of the F8 block. If you do not have a serial printer, enter an 8 in this position.

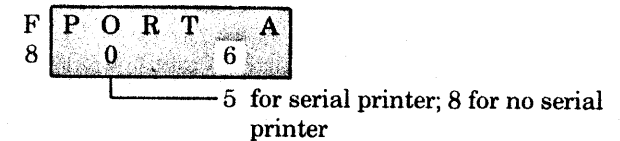

- 19** At the second position in block F8, if you have a serial graphics printer, enter an A. If you do not have a serial graphics printer, just go to the next step.

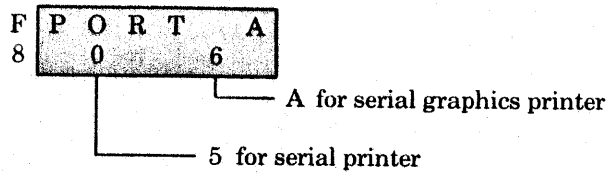

- 20** The lighted blocks should now look like this (be sure to read the notes following this illustration):

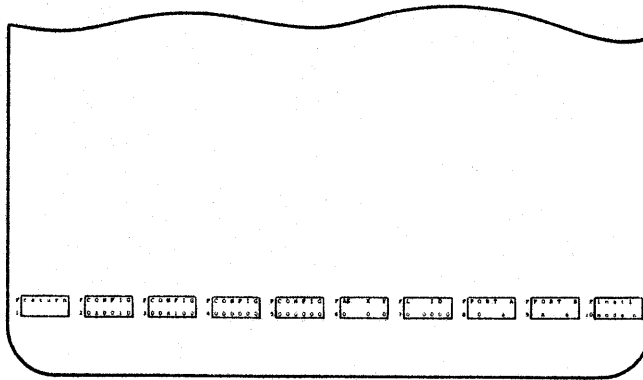

NOTES: If you have a serial-interface board, block F2, position 3 should be a 1.

If you have a parallel graphics printer, block F2, position 4 should be a 1.

If you have a flexible-disk drive, block F2, position 5 should be a 1.

If you have a serial graphics printer, block F2, position 6 should be a 1.

If you have an internal modem, block F3, position 1 should be a 1.

If you have a graphics board, block F3, position 3 should be a 1.

If you have a parallel-interface board, block F3, position 4 should be a 1.

If you have an internal modem that will use tone dialing, block F4, position 4 should be a 1.

If you have a keycap kit, block F7, position 1 should be a 2 for French, 3 for German, 4 for Swedish/Finnish, 5 for United Kingdom, 6 for Spanish, or 7 for Danish/Norwegian.

If you have a serial printer, block F8, position 1 should be a 5. If you do not have a serial printer, position 1 should be an 8.

If you have a serial graphics printer, block F8 position 2 should be an A.

- 21** No entries are needed in the other blocks at this time.

NOTE: If and when you add additional items to your terminal, or when you use an application program, you may make other entries to these blocks.

- 22** Recheck all your entries. Then press the COPY key. This records your entries into the display terminal memory.

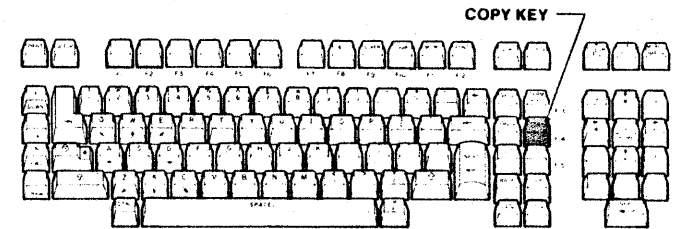

- 23** If you made any changes to the default terminal installation parameters, use a pencil and record the new entries on the screen in the following boxes. Having a record of any changes will make re-entry easier if it is needed in the future. Whenever you change terminal installation parameters, you should also change this record.

F2	<input type="text"/>	<input type="text"/>	<input type="text"/>	<input type="text"/>	F3	<input type="text"/>	<input type="text"/>	<input type="text"/>	<input type="text"/>
F4	<input type="text"/>	<input type="text"/>	<input type="text"/>	<input type="text"/>	F5	<input type="text"/>	<input type="text"/>	<input type="text"/>	<input type="text"/>
F6	<input type="text"/>	<input type="text"/>	<input type="text"/>		F7	<input type="text"/>	<input type="text"/>	<input type="text"/>	<input type="text"/>
F8	<input type="text"/>	<input type="text"/>			F9	<input type="text"/>	<input type="text"/>		

Setting Mode Installation Parameters

- 1 Press the F10 key to continue on to the mode installation parameters.

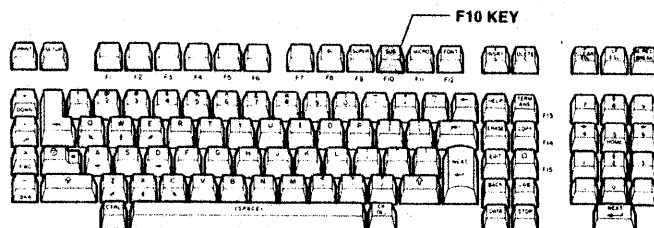

- 2 The screen then displays:

ENTER MODE n (1-6)

The terminal uses the numbers 1 through 7 as identifying numbers for operating modes:

Mode 1—CYBER®

Mode 2—PLATO®

Mode 3—CP/M

Mode 4—DISK

Mode 5—C120

Mode 6—user-assigned mode

Mode 7—PACK

Parameters for modes 1 through 5 are preset. (These preset parameters are recorded on the Default Mode Installation Parameter Record.) Modes 3, 4, and 5 may have their names changed to create additional user-assigned modes. Except for mode 7, each mode to be used needs a separate set of mode installation parameters. Mode 7 is for factory use and is to be disregarded.

Enter the identifying number for the mode the terminal is to operate in. Use the keys in the numeric pad on the right side of the keyboard.

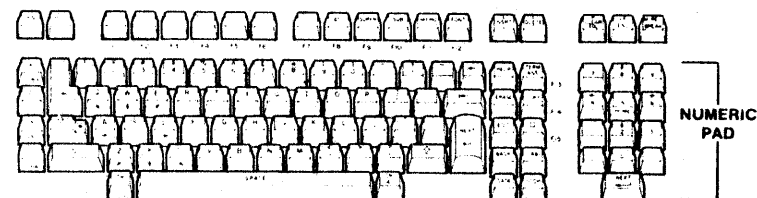

- 3 If you entered a 1 or 2, the preset mode installation parameters for CYBER or PLATO mode appear on the screen. Skip the next two steps if you entered a 1 or 2.

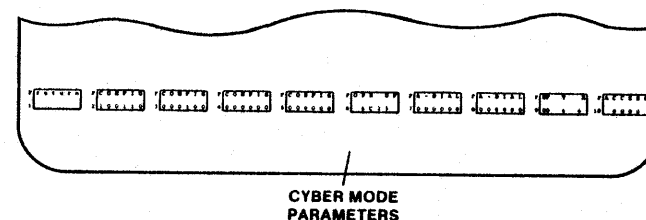

- 4 If you entered a 3, 4, 5, or 6, the screen appears like this:

ENTER MODE NAME

For modes 3, 4, and 5, the preassigned mode name is displayed in the boxes.

If a mode name is displayed and you do not want to change it, press the NEXT key. If you entered a 6 (user-assigned mode), or wish to change the mode name of modes 3, 4, or 5, enter four alphanumeric characters to serve as the mode name and press COPY. The new mode name will appear in the Mode Selection display.

NOTE: Alphanumeric describes a vocabulary consisting of the letters of the alphabet, a through z; the numbers 0 through 9; and a set of special symbols.

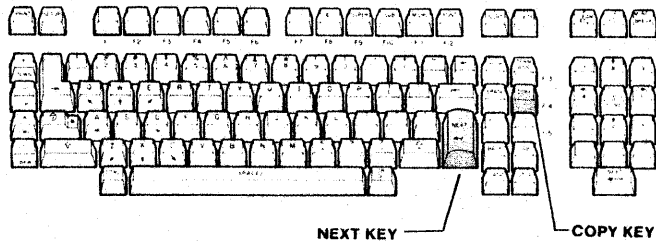

5 The preset mode installation parameters for the mode whose number you entered in step 2 appear on the screen. A typical display is shown here:

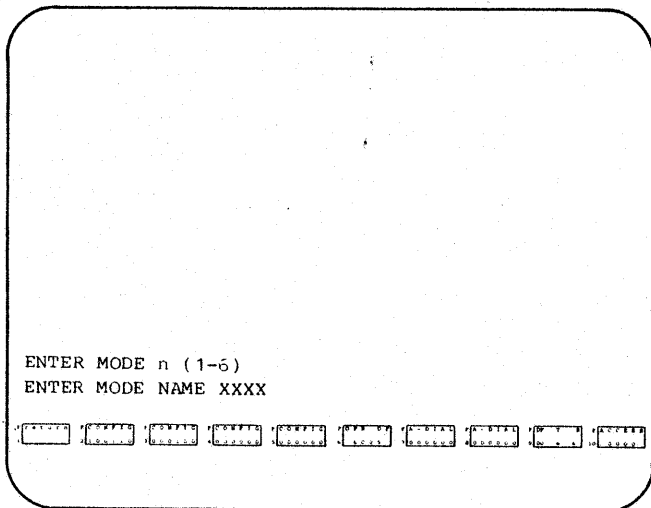

You do not need to change any mode installation parameters at this time.

6 The following is a record of the default mode installation parameters. Use this record to make re-entry easier if it is ever needed.

Default Mode Installation Parameter Record

F2	MODE 1 CYBER	1 0 0 0 0 0 0 0	0 0 0 1 1 0	0 0 0 0 0 0 0	0 1 0 0 0 0 0	4 C 0 4	0 0 0 0 0 0 0	0 0 0 0 0 0 0	0 0 6 6	0 0 0 0 0
F3	MODE 2 PLATO	1 0 0 1 0 0 0	0 0 0 1 1 0	0 0 0 0 0 0 1	0 0 0 0 0 0 0	6 C 2 4	0 0 0 0 0 0 0	0 0 0 0 0 0 0	0 8 6 6	0 0 0 0 0
F4	MODE 3 CP/M	1 0 0 1 1 0	0 0 0 1 0 0	0 0 0 0 0 0 0	0 0 0 0 0 0 0	6 C 2 5	0 0 0 0 0 0 0	0 0 0 0 0 0 0	0 6 6 6	0 0 0 0 0
F5	MODE 4 DISK	1 0 0 1 1 0	0 0 0 1 1 0	0 0 0 0 0 0 1	0 0 0 0 0 0 0	6 C 2 4	0 0 0 0 0 0 0	0 0 0 0 0 0 0	0 6 6 6	0 0 0 0 0
F6	MODE 5 C120	1 0 0 0 0 0 0	0 0 0 0 0 0 0	0 0 0 0 0 0 0	0 0 0 0 0 0 0	4 4 2 1	0 0 0 0 0 0 0	0 0 0 0 0 0 0	0 6 6 6	0 0 0 0 0
F7	MODE 6	0 0 0 0 0 0 0	0 0 0 0 0 0 0	0 0 0 0 0 0 0	0 0 0 0 0 0 0		0 0 0 0 0 0 0	0 0 0 0 0 0 0	0 0 0 0	0 0 0 0 0

- 7** Press the F1 key to return to the Mode Selection display.
Then press RESET.

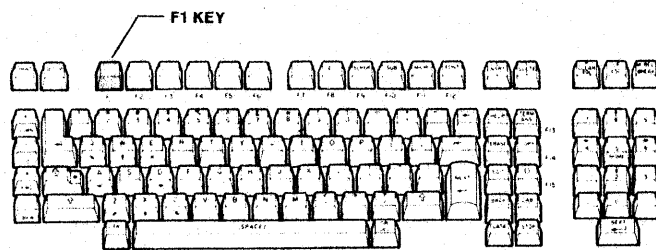

Additional Parameters

This section gives you information on additional parameter settings for:

- An internal modem
- An external modem
- A memory module
- A printer

If you make any changes to the mode installation parameters, record these changes on the Mode Installation Parameter Record at the end of this section.

Internal Modem

If your terminal has an internal modem and will use it to communicate over telephone lines with a computer network or another computer—such as the Control Data CYBERNET® (CYBER mode), or the Control Data Services Network (CDSN) to use PLATO (PLATO mode), or with a Control Data 120 computer (C120 mode)—follow these instructions to enter additional parameters. (If your terminal does not have an internal modem, skip to the heading External Modem.)

When you want your terminal to use any of these computer networks, a load source must be selected (a host computer), and a telephone number must be dialed. (In PLATO mode, a file number must also be selected. The file number allows the host computer to identify the program you want to use.)

There are three ways of doing these tasks: you can do them all yourself (Manual Method), you and the terminal can split the effort (Combination Method), or the terminal can do all the tasks (Automatic Method). Each operating mode may use a different method.

The following paragraphs give a description of each method.

When the parameters are properly set for the Manual Method, you pick up the telephone handpiece, and when you hear the dial tone, dial the phone number of the computer network. When you hear the high-pitched confirmation tone, you press the F key for the mode you will use. When the high-pitched tone drops and you hear a rushing sound, the connection has been made and you can hang up the telephone handpiece.

If you pressed the F1 (CYBER) mode key or the F5 (C120) key, a message from the network appears on the screen.

If you pressed the F2 (PLATO) key, **SELECT LOAD SOURCE > DISK HOST ROM** appears on the screen. You press the H key to select HOST (a computer network) and **SELECT FILE NO. _____** appears. You then type the file number and press NEXT. If the connection has been successfully made, the program from the host computer loads into your terminal.

When the parameters are set properly for the Combination Method, you select the operating mode by pressing one of the F keys. When **ENTER PHONE NUMBER** appears on the screen, you type the telephone number on the keyboard and press NEXT. The terminal then dials the number and **DIALING PHONE NUMBER** appears on the screen. Then **WAITING FOR RING** and **RINGING** appear on the screen. Then:

- In CYBER mode, when the connection is made, a message from the network appears on the screen.
- In PLATO mode, when the connection is made, **SELECT LOAD SOURCE > DISK HOST ROM** appears. You press the H key and **SELECT FILE NO. _____** appears. You then type the file number and press NEXT. **LOADING FILE** appears on the screen as the file from the computer network loads into the terminal's memory.
- In C120 mode, **SELECT LOAD SOURCE > DISK HOST ROM** appears on the screen. You press the R key and then NEXT. When the connection is made, a message from the C120 appears on the screen.

When the parameters are set properly for the Automatic Method, the terminal performs all the tasks for you. You press the F key for the mode you want to use, and the terminal then selects the host computer, dials the phone number, and fills in the file number.

Now it sounds as if the Automatic Method is the one to use; however, there is a catch. When using the Automatic Method, the terminal can store only one telephone number (or two numbers if the numbers are short enough). If you use the Manual or the Combination Methods, you can call any number of telephone numbers.

To set the parameters for the Manual Method:

- 1 If the terminal is not turned on, turn it on. If it is turned on, press RESET.
- 2 When the Mode Selection display is at the bottom of the screen, while pressing the CTRL key, press the SETUP key.
- 3 Press the F10 key.
- 4 When the **ENTER MODE n (1-6)** message appears, enter the number of the mode you want to set up for the Manual Method. If you entered a 3, 4, 5, or 6, press the NEXT key.
- 5 When the Mode installation parameters for the mode you selected appear, change the following parameters as necessary so they appear like this:

- F2, position 1 is a 1.
- F2, position 3 is a 0 for CYBER and C120. F2, position 3 is a 1 for PLATO.
- F2, position 4 is a 0 for CYBER and C120. F2, position 4 is a 1 for PLATO.
- F2, position 5 is a 0.
- F2, position 6 is a 1.

- F3, position 2 is a 0.
- F9 positions are 00 6 6.

- 6** Press the COPY key.
- 7** Press the F1 key.
- 8** Repeat steps 2 through 7 for each mode you want to use the Manual Method.

To set the parameters for the Combination Method:

- 1** If the terminal is not turned on, turn it on. If it is turned on, press RESET.
- 2** While pressing the CTRL key, press the SETUP key.
- 3** Press the F10 key.
- 4** When the ENTER MODE n (1-6) message appears, enter the number of the mode you want to set up for the Combination Method. If you entered a 3, 4, 5, or 6, press the NEXT key.
- 5** When the Mode installation parameters for the mode you selected appear, change the following parameters as necessary so they appear like this:

- F2, position 1 is a 1.
- F2, position 3 is a 1.
- F2, position 4 is a 1.
- F2, position 5 is a 0.
- F2, position 6 is a 1.
- F3, position 2 is a 1.
- F9 positions are 00 6 6.

- 6** Press the COPY key.
- 7** Press the F1 key.
- 8** Repeat steps 2 through 7 for each mode you want to use the Combination Method.

To set the parameters for the Automatic Method:

- 1** If the terminal is not turned on, turn it on. If it is turned on, press RESET.
- 2** While pressing the CTRL key, press the SETUP key.
- 3** Press the F10 key.
- 4** When the ENTER MODE n (1-6) message appears, enter the number of the mode you want to set up for the Automatic Method. If you entered a 3, 4, 5, or 6, press the NEXT key.
- 5** When the Mode installation parameters for the mode you selected appear, change the following parameters as necessary so they appear like this:

- F2, position 1 is a 1.
- F2, position 3 is a 0.
- F2, position 4 is a 0.
- F2, position 5 is a 0.
- F2, position 6 is a 1.
- F3, position 2 is a 1.
- F9 positions are 00 6 6, except in PLATO mode where these positions should be 08 6 6.

NOTE: If the network you are using assigned you a file number, enter the file number in the first two positions of F9.

- 6** Press the F7 key, and when the cursor moves to the F7 block, type the telephone number you want to be automatically dialed. When you type the phone number, the number may also fill part of the F8 block. Follow the phone number with an F if the number does not fill the F8 block.

NOTE: If your terminal is part of a CDC 110 Microcomputer System using CP/M, the auto-dial phone number may be recorded using the Phone Utility on the CP/M disk. See your CP/M manual for more information.

If there is an * in the phone number, type a B instead. If there is a # in the phone number, type a C instead. If there is enough room for two phone numbers, type an A after the first phone number. Then type the second phone number. [If the terminal does not get an answer on the first phone number, it will try the second (alternate) phone number.]

NOTE: This note tells you how to cause pauses in the automatic dialing. If you don't know if pauses are needed, complete these steps and then try the automatic dialing by pressing the F key for the mode that will use automatic dialing. If you get a HOST LOAD FAIL message on the screen, repeat steps 1 through 9 and add a D or an E as described in this note.

Frequently a 9 (or some other number) must be dialed to get to an outside line. In some cases you may want the automatic dialing to pause after the 9 to wait for a dial tone. To cause a pause in the dialing, type a D between the 9 and the next number.

In some areas you may have to cause a 3-second delay between a direct-dial access number and the area-code number or between the area-code number and the actual phone number. To do this, type an E between the numbers where needed.

- 7** If the telephone number does not fill all the spaces of the F7 and F8 blocks, enter an F after the phone number.

- 8** At this time, you should decide if you want the internal modem to dial once or continuously until a connection is made. With continuous dialing, the internal modem calls the first specified number, and if no connection is made, it calls the second specified number. If no connection is made with the second number, the modem retries the first number. This cycle continues until a connection is made, or the terminal is reset, or the M REL/BREAK key is pressed. If you want the modem to dial continuously, press the F3 key. If necessary, change position 1 of the F3 block to a 1.
- 9** If you are setting these parameters for PLATO mode, press the F9 key and enter the file number you want to be automatically loaded. (Note that PLATO mode is preset for file 08.)
- 10** Press the COPY key.
- 11** Press the F1 key.
- 12** Repeat steps 2 through 7 for each mode you want to use the Automatic Method.

External Modem

If you connect an external modem to the terminal, some of the parameters may have to be changed. However, the default parameters are set so the terminal will work with most external modems. Connect your modem to the telephone lines (described in Cable Connections). Then try to call and connect the modem to the network or computer you will be using (described in the Using Modems section in the Operating Guide).

If you cannot make the connection, you may have to change parameters. The parameter most likely to be affected is mode installation parameter F9, positions 2 and 3. These positions let you select the baud rate used in transmission to and from your host computer. (Baud rate is a measure of speed at which data is transmitted.) The baud rate for these positions should be the same as your modem's baud rate. Check the application information from the modem manufacturer to determine your modem's baud rate.

For modes other than the standard modes (CYBER, PLATO, CP/M, C120), you may also have to change the following mode installation parameters:

- F2, positions 3, 4, 5, and 6
- F3, positions 3, 4, 5, and 6
- F4, positions 1, 2, and 4
- F5, position 1
- F9, position 1

Turn to the complete list of parameters in the appendix for a more detailed explanation of each of these parameters.

Memory Module

See your memory module manual for information on memory module parameters.

Printer

If you connect a printer to the terminal, some of the parameters may have to be changed. However, the default parameters are set so the terminal will work with most printers. If you have not yet done so, connect your printer to the terminal (described in Cable Connections). Then try to operate your printer. (See your printer manual for operating information.) If you cannot make the printer operate properly, you may have to change parameters.

For a parallel printer, check terminal installation parameter F4, position 5.

For a serial printer, check your printer manual for information to help you in making parameter changes. Look for information to answer the following questions:

- What is the printer's baud rate? (Baud rate is a measure of speed at which data is transmitted.)
- Does the printer use parity checking?
- If the printer uses parity checking, is parity to be even or odd?
- What is the byte size used in communications with the printer? (The byte size is the number of bits in a character that the printer will accept in words from the terminal.)
- What kind of buffer status and printer status signals does your printer use?

For a serial printer, check terminal installation parameters:

- F4, positions 2 and 5
- F8, positions 1 and 2
- F9, positions 1 and 2

Turn to the complete list of parameters in the appendix for a more detailed explanation of each of these parameters. (If you make any changes to these parameters, record the changes on the Terminal Installation Parameter Record.)

NOTE: If the printer still will not operate properly, check that switches or parameters on the printer are set correctly. (See your printer manual for this information.)

Mode Installation Parameter Record

If you make any changes to the default mode installation parameters, use a pencil and record the changes on the following Parameter Record. Having a record of any changes will make re-entry easier if it is ever needed. Whenever you change mode installation parameters, you should also change this record.

F 1	MODE 1 CYBER	<input type="checkbox"/>	<input type="checkbox"/>	<input type="checkbox"/>	<input type="checkbox"/>	<input type="checkbox"/>	<input type="checkbox"/>	<input type="checkbox"/>	<input type="checkbox"/>	<input type="checkbox"/>	<input type="checkbox"/>	<input type="checkbox"/>	<input type="checkbox"/>
F2		<input type="checkbox"/>	<input type="checkbox"/>	<input type="checkbox"/>	<input type="checkbox"/>	<input type="checkbox"/>	<input type="checkbox"/>	<input type="checkbox"/>	<input type="checkbox"/>	<input type="checkbox"/>	<input type="checkbox"/>	<input type="checkbox"/>	<input type="checkbox"/>
F3		<input type="checkbox"/>	<input type="checkbox"/>	<input type="checkbox"/>	<input type="checkbox"/>	<input type="checkbox"/>	<input type="checkbox"/>	<input type="checkbox"/>	<input type="checkbox"/>	<input type="checkbox"/>	<input type="checkbox"/>	<input type="checkbox"/>	<input type="checkbox"/>
F4		<input type="checkbox"/>	<input type="checkbox"/>	<input type="checkbox"/>	<input type="checkbox"/>	<input type="checkbox"/>	<input type="checkbox"/>	<input type="checkbox"/>	<input type="checkbox"/>	<input type="checkbox"/>	<input type="checkbox"/>	<input type="checkbox"/>	<input type="checkbox"/>
F5		<input type="checkbox"/>	<input type="checkbox"/>	<input type="checkbox"/>	<input type="checkbox"/>	<input type="checkbox"/>	<input type="checkbox"/>	<input type="checkbox"/>	<input type="checkbox"/>	<input type="checkbox"/>	<input type="checkbox"/>	<input type="checkbox"/>	<input type="checkbox"/>
F6		<input type="checkbox"/>	<input type="checkbox"/>	<input type="checkbox"/>	<input type="checkbox"/>	<input type="checkbox"/>	<input type="checkbox"/>	<input type="checkbox"/>	<input type="checkbox"/>	<input type="checkbox"/>	<input type="checkbox"/>	<input type="checkbox"/>	<input type="checkbox"/>
F7		<input type="checkbox"/>	<input type="checkbox"/>	<input type="checkbox"/>	<input type="checkbox"/>	<input type="checkbox"/>	<input type="checkbox"/>	<input type="checkbox"/>	<input type="checkbox"/>	<input type="checkbox"/>	<input type="checkbox"/>	<input type="checkbox"/>	<input type="checkbox"/>
F8		<input type="checkbox"/>	<input type="checkbox"/>	<input type="checkbox"/>	<input type="checkbox"/>	<input type="checkbox"/>	<input type="checkbox"/>	<input type="checkbox"/>	<input type="checkbox"/>	<input type="checkbox"/>	<input type="checkbox"/>	<input type="checkbox"/>	<input type="checkbox"/>
F9		<input type="checkbox"/>	<input type="checkbox"/>	<input type="checkbox"/>	<input type="checkbox"/>	<input type="checkbox"/>	<input type="checkbox"/>	<input type="checkbox"/>	<input type="checkbox"/>	<input type="checkbox"/>	<input type="checkbox"/>	<input type="checkbox"/>	<input type="checkbox"/>
F10		<input type="checkbox"/>	<input type="checkbox"/>	<input type="checkbox"/>	<input type="checkbox"/>	<input type="checkbox"/>	<input type="checkbox"/>	<input type="checkbox"/>	<input type="checkbox"/>	<input type="checkbox"/>	<input type="checkbox"/>	<input type="checkbox"/>	<input type="checkbox"/>
F 2	MODE 2 PLATO	<input type="checkbox"/>	<input type="checkbox"/>	<input type="checkbox"/>	<input type="checkbox"/>	<input type="checkbox"/>	<input type="checkbox"/>	<input type="checkbox"/>	<input type="checkbox"/>	<input type="checkbox"/>	<input type="checkbox"/>	<input type="checkbox"/>	<input type="checkbox"/>
F3		<input type="checkbox"/>	<input type="checkbox"/>	<input type="checkbox"/>	<input type="checkbox"/>	<input type="checkbox"/>	<input type="checkbox"/>	<input type="checkbox"/>	<input type="checkbox"/>	<input type="checkbox"/>	<input type="checkbox"/>	<input type="checkbox"/>	<input type="checkbox"/>
F4		<input type="checkbox"/>	<input type="checkbox"/>	<input type="checkbox"/>	<input type="checkbox"/>	<input type="checkbox"/>	<input type="checkbox"/>	<input type="checkbox"/>	<input type="checkbox"/>	<input type="checkbox"/>	<input type="checkbox"/>	<input type="checkbox"/>	<input type="checkbox"/>
F5		<input type="checkbox"/>	<input type="checkbox"/>	<input type="checkbox"/>	<input type="checkbox"/>	<input type="checkbox"/>	<input type="checkbox"/>	<input type="checkbox"/>	<input type="checkbox"/>	<input type="checkbox"/>	<input type="checkbox"/>	<input type="checkbox"/>	<input type="checkbox"/>
F6		<input type="checkbox"/>	<input type="checkbox"/>	<input type="checkbox"/>	<input type="checkbox"/>	<input type="checkbox"/>	<input type="checkbox"/>	<input type="checkbox"/>	<input type="checkbox"/>	<input type="checkbox"/>	<input type="checkbox"/>	<input type="checkbox"/>	<input type="checkbox"/>
F7		<input type="checkbox"/>	<input type="checkbox"/>	<input type="checkbox"/>	<input type="checkbox"/>	<input type="checkbox"/>	<input type="checkbox"/>	<input type="checkbox"/>	<input type="checkbox"/>	<input type="checkbox"/>	<input type="checkbox"/>	<input type="checkbox"/>	<input type="checkbox"/>
F8		<input type="checkbox"/>	<input type="checkbox"/>	<input type="checkbox"/>	<input type="checkbox"/>	<input type="checkbox"/>	<input type="checkbox"/>	<input type="checkbox"/>	<input type="checkbox"/>	<input type="checkbox"/>	<input type="checkbox"/>	<input type="checkbox"/>	<input type="checkbox"/>
F9		<input type="checkbox"/>	<input type="checkbox"/>	<input type="checkbox"/>	<input type="checkbox"/>	<input type="checkbox"/>	<input type="checkbox"/>	<input type="checkbox"/>	<input type="checkbox"/>	<input type="checkbox"/>	<input type="checkbox"/>	<input type="checkbox"/>	<input type="checkbox"/>
F10		<input type="checkbox"/>	<input type="checkbox"/>	<input type="checkbox"/>	<input type="checkbox"/>	<input type="checkbox"/>	<input type="checkbox"/>	<input type="checkbox"/>	<input type="checkbox"/>	<input type="checkbox"/>	<input type="checkbox"/>	<input type="checkbox"/>	<input type="checkbox"/>
F 3	MODE 3 CP/M	<input type="checkbox"/>	<input type="checkbox"/>	<input type="checkbox"/>	<input type="checkbox"/>	<input type="checkbox"/>	<input type="checkbox"/>	<input type="checkbox"/>	<input type="checkbox"/>	<input type="checkbox"/>	<input type="checkbox"/>	<input type="checkbox"/>	<input type="checkbox"/>
F4		<input type="checkbox"/>	<input type="checkbox"/>	<input type="checkbox"/>	<input type="checkbox"/>	<input type="checkbox"/>	<input type="checkbox"/>	<input type="checkbox"/>	<input type="checkbox"/>	<input type="checkbox"/>	<input type="checkbox"/>	<input type="checkbox"/>	<input type="checkbox"/>
F5		<input type="checkbox"/>	<input type="checkbox"/>	<input type="checkbox"/>	<input type="checkbox"/>	<input type="checkbox"/>	<input type="checkbox"/>	<input type="checkbox"/>	<input type="checkbox"/>	<input type="checkbox"/>	<input type="checkbox"/>	<input type="checkbox"/>	<input type="checkbox"/>
F6		<input type="checkbox"/>	<input type="checkbox"/>	<input type="checkbox"/>	<input type="checkbox"/>	<input type="checkbox"/>	<input type="checkbox"/>	<input type="checkbox"/>	<input type="checkbox"/>	<input type="checkbox"/>	<input type="checkbox"/>	<input type="checkbox"/>	<input type="checkbox"/>
F7		<input type="checkbox"/>	<input type="checkbox"/>	<input type="checkbox"/>	<input type="checkbox"/>	<input type="checkbox"/>	<input type="checkbox"/>	<input type="checkbox"/>	<input type="checkbox"/>	<input type="checkbox"/>	<input type="checkbox"/>	<input type="checkbox"/>	<input type="checkbox"/>
F8		<input type="checkbox"/>	<input type="checkbox"/>	<input type="checkbox"/>	<input type="checkbox"/>	<input type="checkbox"/>	<input type="checkbox"/>	<input type="checkbox"/>	<input type="checkbox"/>	<input type="checkbox"/>	<input type="checkbox"/>	<input type="checkbox"/>	<input type="checkbox"/>
F9		<input type="checkbox"/>	<input type="checkbox"/>	<input type="checkbox"/>	<input type="checkbox"/>	<input type="checkbox"/>	<input type="checkbox"/>	<input type="checkbox"/>	<input type="checkbox"/>	<input type="checkbox"/>	<input type="checkbox"/>	<input type="checkbox"/>	<input type="checkbox"/>
F10		<input type="checkbox"/>	<input type="checkbox"/>	<input type="checkbox"/>	<input type="checkbox"/>	<input type="checkbox"/>	<input type="checkbox"/>	<input type="checkbox"/>	<input type="checkbox"/>	<input type="checkbox"/>	<input type="checkbox"/>	<input type="checkbox"/>	<input type="checkbox"/>
F 4	MODE 4 DISK	<input type="checkbox"/>	<input type="checkbox"/>	<input type="checkbox"/>	<input type="checkbox"/>	<input type="checkbox"/>	<input type="checkbox"/>	<input type="checkbox"/>	<input type="checkbox"/>	<input type="checkbox"/>	<input type="checkbox"/>	<input type="checkbox"/>	<input type="checkbox"/>
F5		<input type="checkbox"/>	<input type="checkbox"/>	<input type="checkbox"/>	<input type="checkbox"/>	<input type="checkbox"/>	<input type="checkbox"/>	<input type="checkbox"/>	<input type="checkbox"/>	<input type="checkbox"/>	<input type="checkbox"/>	<input type="checkbox"/>	<input type="checkbox"/>
F6		<input type="checkbox"/>	<input type="checkbox"/>	<input type="checkbox"/>	<input type="checkbox"/>	<input type="checkbox"/>	<input type="checkbox"/>	<input type="checkbox"/>	<input type="checkbox"/>	<input type="checkbox"/>	<input type="checkbox"/>	<input type="checkbox"/>	<input type="checkbox"/>
F7		<input type="checkbox"/>	<input type="checkbox"/>	<input type="checkbox"/>	<input type="checkbox"/>	<input type="checkbox"/>	<input type="checkbox"/>	<input type="checkbox"/>	<input type="checkbox"/>	<input type="checkbox"/>	<input type="checkbox"/>	<input type="checkbox"/>	<input type="checkbox"/>
F8		<input type="checkbox"/>	<input type="checkbox"/>	<input type="checkbox"/>	<input type="checkbox"/>	<input type="checkbox"/>	<input type="checkbox"/>	<input type="checkbox"/>	<input type="checkbox"/>	<input type="checkbox"/>	<input type="checkbox"/>	<input type="checkbox"/>	<input type="checkbox"/>
F9		<input type="checkbox"/>	<input type="checkbox"/>	<input type="checkbox"/>	<input type="checkbox"/>	<input type="checkbox"/>	<input type="checkbox"/>	<input type="checkbox"/>	<input type="checkbox"/>	<input type="checkbox"/>	<input type="checkbox"/>	<input type="checkbox"/>	<input type="checkbox"/>
F10		<input type="checkbox"/>	<input type="checkbox"/>	<input type="checkbox"/>	<input type="checkbox"/>	<input type="checkbox"/>	<input type="checkbox"/>	<input type="checkbox"/>	<input type="checkbox"/>	<input type="checkbox"/>	<input type="checkbox"/>	<input type="checkbox"/>	<input type="checkbox"/>
F 5	MODE 5 C120	<input type="checkbox"/>	<input type="checkbox"/>	<input type="checkbox"/>	<input type="checkbox"/>	<input type="checkbox"/>	<input type="checkbox"/>	<input type="checkbox"/>	<input type="checkbox"/>	<input type="checkbox"/>	<input type="checkbox"/>	<input type="checkbox"/>	<input type="checkbox"/>
F6		<input type="checkbox"/>	<input type="checkbox"/>	<input type="checkbox"/>	<input type="checkbox"/>	<input type="checkbox"/>	<input type="checkbox"/>	<input type="checkbox"/>	<input type="checkbox"/>	<input type="checkbox"/>	<input type="checkbox"/>	<input type="checkbox"/>	<input type="checkbox"/>
F7		<input type="checkbox"/>	<input type="checkbox"/>	<input type="checkbox"/>	<input type="checkbox"/>	<input type="checkbox"/>	<input type="checkbox"/>	<input type="checkbox"/>	<input type="checkbox"/>	<input type="checkbox"/>	<input type="checkbox"/>	<input type="checkbox"/>	<input type="checkbox"/>
F8		<input type="checkbox"/>	<input type="checkbox"/>	<input type="checkbox"/>	<input type="checkbox"/>	<input type="checkbox"/>	<input type="checkbox"/>	<input type="checkbox"/>	<input type="checkbox"/>	<input type="checkbox"/>	<input type="checkbox"/>	<input type="checkbox"/>	<input type="checkbox"/>
F9		<input type="checkbox"/>	<input type="checkbox"/>	<input type="checkbox"/>	<input type="checkbox"/>	<input type="checkbox"/>	<input type="checkbox"/>	<input type="checkbox"/>	<input type="checkbox"/>	<input type="checkbox"/>	<input type="checkbox"/>	<input type="checkbox"/>	<input type="checkbox"/>
F10		<input type="checkbox"/>	<input type="checkbox"/>	<input type="checkbox"/>	<input type="checkbox"/>	<input type="checkbox"/>	<input type="checkbox"/>	<input type="checkbox"/>	<input type="checkbox"/>	<input type="checkbox"/>	<input type="checkbox"/>	<input type="checkbox"/>	<input type="checkbox"/>
F 6	MODE 6	<input type="checkbox"/>	<input type="checkbox"/>	<input type="checkbox"/>	<input type="checkbox"/>	<input type="checkbox"/>	<input type="checkbox"/>	<input type="checkbox"/>	<input type="checkbox"/>	<input type="checkbox"/>	<input type="checkbox"/>	<input type="checkbox"/>	<input type="checkbox"/>
F7		<input type="checkbox"/>	<input type="checkbox"/>	<input type="checkbox"/>	<input type="checkbox"/>	<input type="checkbox"/>	<input type="checkbox"/>	<input type="checkbox"/>	<input type="checkbox"/>	<input type="checkbox"/>	<input type="checkbox"/>	<input type="checkbox"/>	<input type="checkbox"/>
F8		<input type="checkbox"/>	<input type="checkbox"/>	<input type="checkbox"/>	<input type="checkbox"/>	<input type="checkbox"/>	<input type="checkbox"/>	<input type="checkbox"/>	<input type="checkbox"/>	<input type="checkbox"/>	<input type="checkbox"/>	<input type="checkbox"/>	<input type="checkbox"/>
F9		<input type="checkbox"/>	<input type="checkbox"/>	<input type="checkbox"/>	<input type="checkbox"/>	<input type="checkbox"/>	<input type="checkbox"/>	<input type="checkbox"/>	<input type="checkbox"/>	<input type="checkbox"/>	<input type="checkbox"/>	<input type="checkbox"/>	<input type="checkbox"/>
F10		<input type="checkbox"/>	<input type="checkbox"/>	<input type="checkbox"/>	<input type="checkbox"/>	<input type="checkbox"/>	<input type="checkbox"/>	<input type="checkbox"/>	<input type="checkbox"/>	<input type="checkbox"/>	<input type="checkbox"/>	<input type="checkbox"/>	<input type="checkbox"/>

Introduction

This section describes the normal everyday operations done by anyone using the display terminal. Such operations include turning the terminal on and off, using the keyboard, and loading the operating mode.

Also included is a Changing Parameters section that explains how to change the terminal and mode installation parameters when your requirements change or when you add an additional item to the terminal.

When you finish reading the Operating Guide, go to the guides or manuals for the application where your terminal will be used.

Overview

Your display terminal is a versatile terminal for use as a stand-alone unit or as part of a CDC 110 Microcomputer System. The terminal may be:

- Included as part of a communications network
- Linked to a remote computer via phone
- Cabled directly to a local computer
- Set up with a character printer or graphics printer

The terminal contains a permanently stored operating program that controls the terminal and lets it communicate with computer systems of the CDC CYBER series. This operating program is called CYBER mode.

You can also load different operating programs (operating modes) into the terminal's memory. Operating modes can be loaded from:

- The computer your terminal is linked to
- A memory module plugged in the rear of the terminal
- A flexible disk (in a CDC 110 Microcomputer System)

Many operating characteristics of the terminal are determined by guidelines (parameters) first selected during installation. These parameters are stored in the terminal's non-volatile (permanent) memory.

Certain parameters (operator parameters) may be temporarily changed. These changes may be made by you or by the computer your terminal is linked to.

You can increase the capabilities of your terminal by adding printed-circuit boards to the terminal. The boards include:

- The serial-interface board
- The parallel-interface board
- The graphics board
- The 1200/1200-baud internal modem

Your terminal may or may not have any of these boards.

Power-On

NOTE: If your terminal is cabled directly to a local computer, the power-on in the next step must be done along with the power-on for the computer.

- 1** Turn on the terminal by pressing the side of the POWER switch marked with a 1. Turn on any additional items connected to the terminal, such as printers or flexible-disk drives.

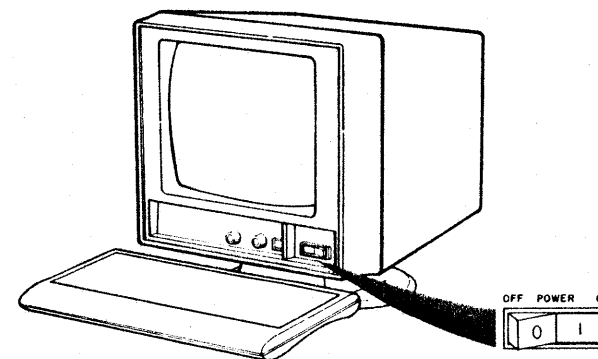

- 2 The terminal does a self test. The test may take up to 20 seconds with an internal modem installed or about 6 seconds without an internal modem. The terminal "beeps" at the end of the self test to tell you that everything is working fine.

If the self test finds a problem with the terminal, the ERROR indicator lights and message(s) display on the screen. The message(s) call your attention to the item(s) that failed. Turn to the Screen Messages in the Problem Solving Guide if a FAIL message appears on the screen.

- 3 Watch the bottom of the screen. In about 20 seconds, as the terminal warms up, a row of lighted blocks appears. This row of lighted blocks is the Mode Selection display.

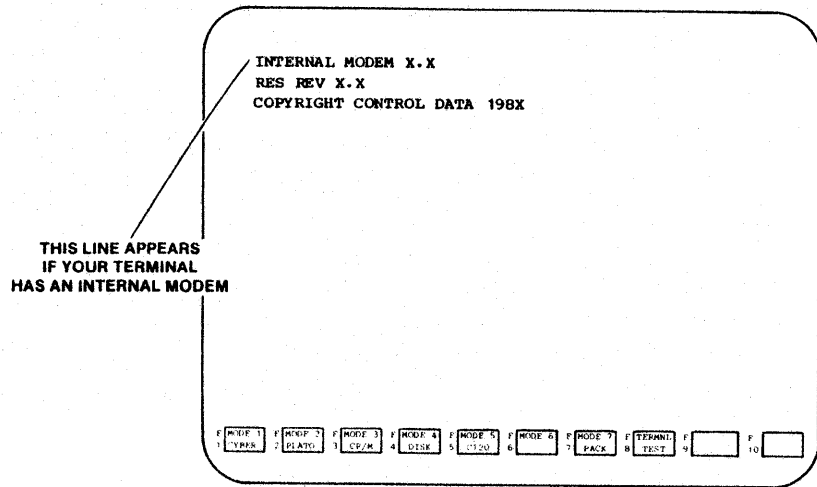

NOTE: X's represent numbers that may vary.

NOTE: If your terminal is set up during installation to automatically select the operating mode, the terminal enters this mode after a power-on or reset. You do not see the Mode Selection display on the screen. To make the Mode Selection display appear:

- a Pull out the TEST switch at the back of the terminal.

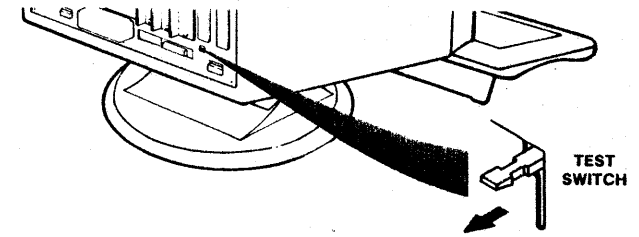

- b Press the RESET switch at the front of the terminal.

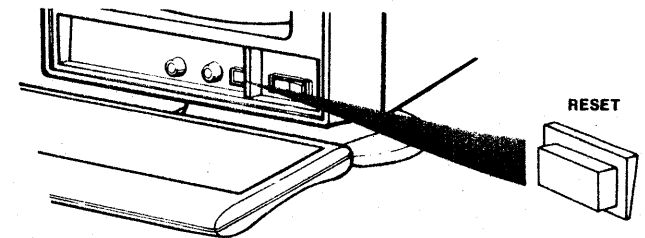

- c Push in the TEST switch when the Mode Selection display appears on the screen.

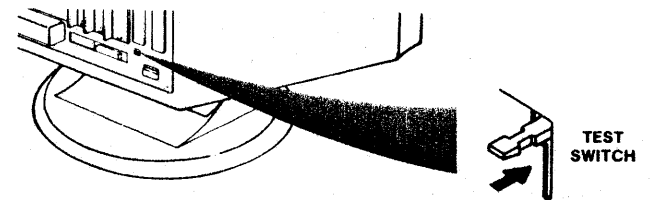

- 4 If you don't see the Mode Selection display, turn the BRIGHTNESS and CONTRAST controls clockwise.

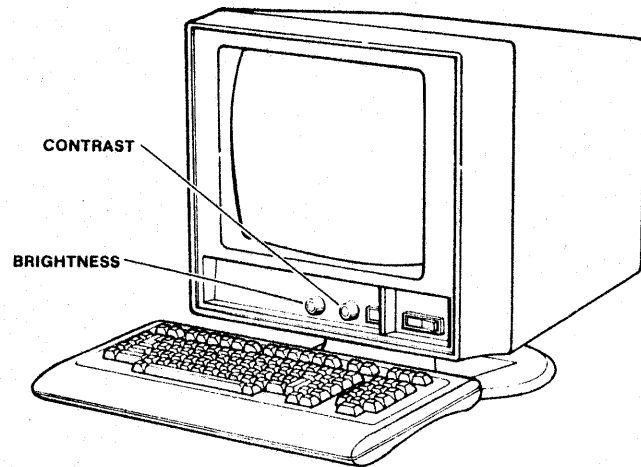

Even if you see the Mode Selection display, try these controls to see what they do.

Then adjust the controls so the background on the screen is dark and you can easily read the letters in the lighted blocks.

- 5 Now press the RESET switch and watch what happens.

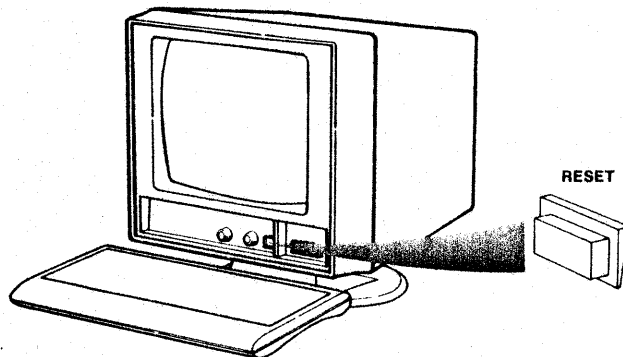

Pressing the RESET switch causes the terminal to stop what it's doing, clear the screen, flash some test patterns, and start all over. The terminal then "beeps" and the Mode Selection display appears again. If you don't see the Mode Selection display, see the note on the preceding page to make the Mode Selection display appear on the screen.

Graphics Feature and Touchpanel

You should know if your terminal has a graphics feature and a touchpanel. A graphics feature lets you use the terminal to make drawings, graphs, and pictures. A touchpanel is a thin piece of plastic that covers the screen. When the touchpanel is active and it is touched, the cursor appears where the touch was made. The touchpanel is often used to choose an item from a number of items appearing on the screen.

NOTE: The cursor is the small light on the screen that tells you where the next character you type on the keyboard will appear on the screen. The cursor can appear as a constant underline, a blinking underline, a solid block, or a blinking solid block.

- 1 With the Mode Selection display on the screen, press the F8 key to select block 8, the TERMINAL TEST.

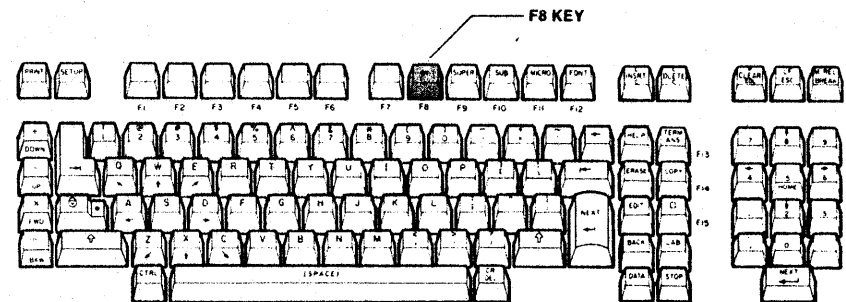

2 If this pattern appears

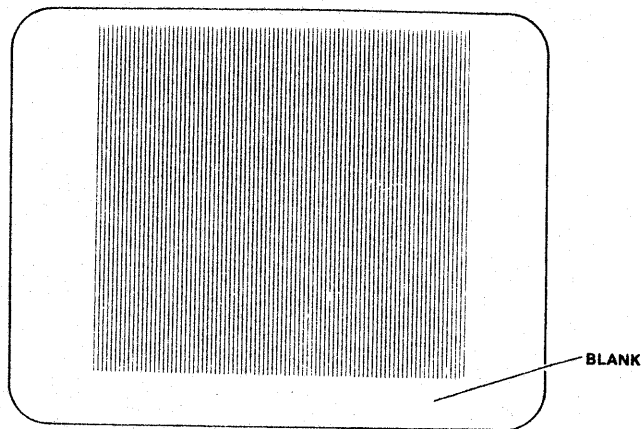

and then changes to this pattern

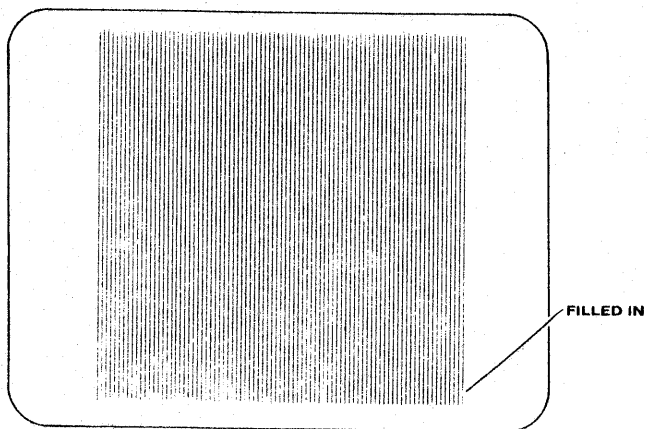

and then the patterns keep changing back and forth, your terminal has a graphics feature.

If you see this test screen, your terminal does not have a graphics feature.

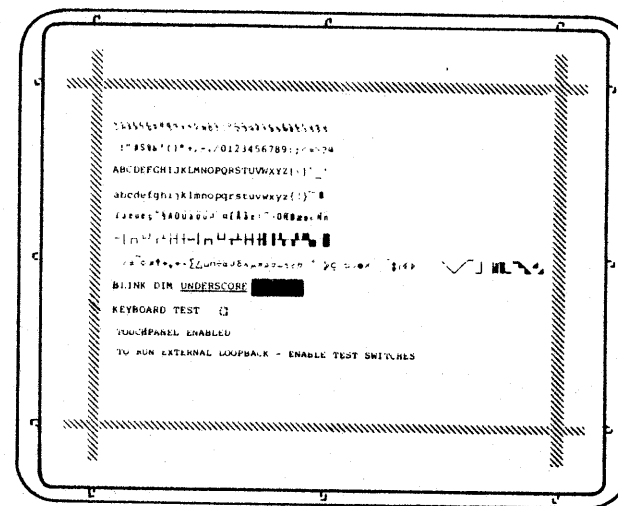

3 If you don't have a graphics feature, reset the terminal by pressing the RESET switch and continue on to the next section.

If you do have a graphics feature, press the F8 key again. A test screen then appears. To find out if your terminal has a touchpanel, touch the screen and look to see if the cursor moves to the area you touched.

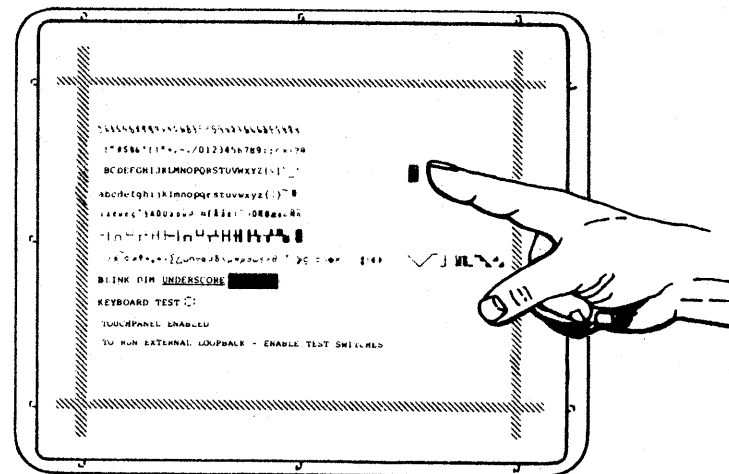

Move the cursor as often as you wish. Then reset the terminal by pressing the RESET switch and continue on to the next section.

If you see this test screen, your terminal does not have a graphics feature.

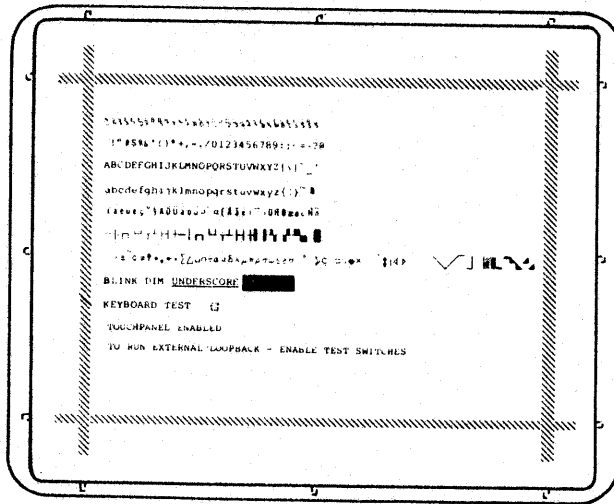

- 3 If you don't have a graphics feature, reset the terminal by pressing the RESET switch and continue on to the next section.

If you do have a graphics feature, press the F8 key again. A test screen then appears. To find out if your terminal has a touchpanel, touch the screen and look to see if the cursor moves to the area you touched.

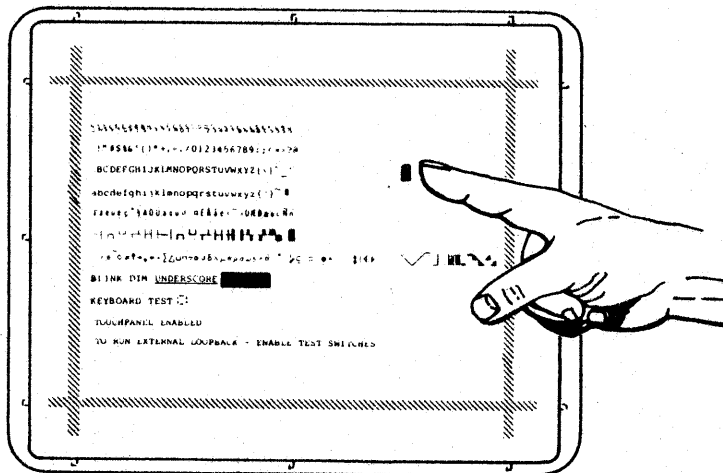

Move the cursor as often as you wish. Then reset the terminal by pressing the RESET switch and continue on to the next section.

POWER Switch

Press the side marked with a 1 to turn the display terminal on. Press the side marked with a 0 to turn the terminal off.

RESET Switch

When the display terminal is turned on, press the RESET switch to clear the display screen and restart the terminal.

CONTRAST Control

Rotate this control to vary the contrast between the image on the screen and the background on the screen.

BRIGHTNESS Control

Rotate this control to vary the brightness of the image on the display screen.

TEST Switch

Only use the TEST switch as described in the Installation section and the Problem Solving Guide. Push the TEST switch in for normal operations.

TEST/NORMAL Switch

You only have this switch if your terminal has a serial-interface board. This switch is used with the TEST switch to test communications between the terminal and any items cabled to the serial-interface board. Push this switch down for normal operations.

LINE VOLTAGE Switch

This switch is preset for the correct line voltage. Do not change the setting of this switch.

CB1 Circuit Breaker

The CB1 circuit breaker is similar to a fuse. It protects the terminal from electrical overloads. Note how far the rod in the center of the circuit breaker sticks out from the back of the terminal. When the terminal is overloaded, the circuit breaker trips, and the rod in the center sticks out farther. If the circuit breaker trips, wait 15 to 20 seconds and press the rod in the center of the circuit breaker. If the circuit breaker keeps tripping, turn to the Display Terminal HELP in the Problem Solving Guide.

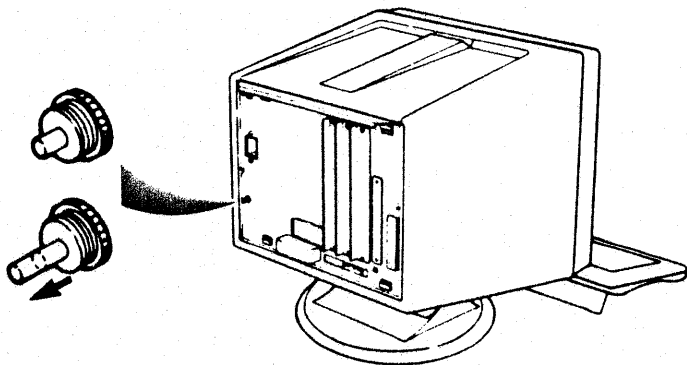

A panel on the front of the terminal has lights that give you information.

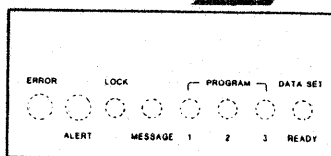
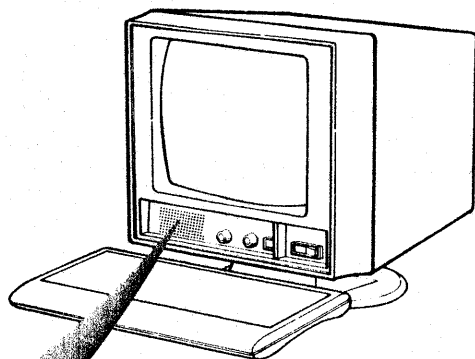

ERROR Light

When the ERROR light comes on and then goes off, an error has occurred during the terminal self test or during a loading operation and the error has been corrected. (Some application programs may use the ERROR light for other purposes.) If the ERROR light comes on and stays on, turn to the Display Terminal HELP in the Problem Solving Guide.

ALERT Light

A lit ALERT light means an error has occurred during a loading operation. When the ALERT light is lit, a message often appears on the screen that explains the condition causing the alert, or the condition may be explained in your application program manuals.

LOCK Light

When the red LOCK light is on, the keyboard has been locked. When the keyboard is locked, you cannot use the keyboard. The keyboard is locked when:

- A page is printed while in CYBER mode
- A block of information is transmitted while in CYBER mode
- Your host computer locks the keyboard
- The terminal is unable to transmit because the modem (a device that connects the terminal to a telephone line) is not ready

MESSAGE Light

When a message is available from a remote computer, the MESSAGE indicator may be lit. If the terminal uses this feature, it is described in your application program manuals.

PROGRAM 1, 2, 3 Lights

If these lights are used, your application program manuals describe how they are used.

DATA SET READY Light

This light is used if the terminal is connected to a computer through a modem. The light means the modem is powered on. If you see the light and also have a telephone-line connection, then the terminal is ready to receive information from the computer.

Alarm

You hear this alarm (a beep):

- At the end of a terminal self test
- When you press a key and the terminal does not expect it to be pressed
- When you move the cursor to the eighth position from the end of a line or to the last line, if your terminal is set up this way

An application program may also use the alarm to indicate an error or to acknowledge a touch on the touchpanel.

Power Connector

The power cord that connects the terminal to electrical power plugs in here.

Access-Cover Latch

This latch must be pushed down to connect the power cord to the back of the terminal.

Parallel-Interface Connector

You only have this connector if your terminal has a parallel-interface board. A cable to a parallel device connects here.

Serial-Interface Connectors

You only have these connectors if your terminal has a serial-interface board. A cable to a serial printer connects to J1. Connector J2 is used to connect other serial devices.

Battery Cover Plate

A 9-volt alkaline battery is located behind this cover plate. The terminal uses this battery to keep its memory active when the terminal is turned off. When the battery is low, a BATTERY LOW message appears on the screen. Turn to the Screen Messages in the Problem Solving Guide for instructions on replacing the battery.

Keycaps

The keycap set on your terminal may be:

- Standard
- French
- German
- Swedish/Finnish
- United Kingdom
- Spanish
- Danish/Norwegian

NOTE: The  key of the French, German, Swedish/Finnish, Danish/Norwegian, and Spanish keycap sets produces a unique code sequence that is only used for PLATO applications. This unique code sequence does not correspond with the symbols on the key.

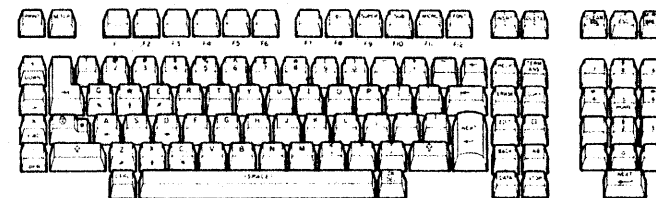

Keyboard with Standard Keycaps

NOTE:
OPTIONAL KEYCAPS ARE SHADED FOR ILLUSTRATING PURPOSES

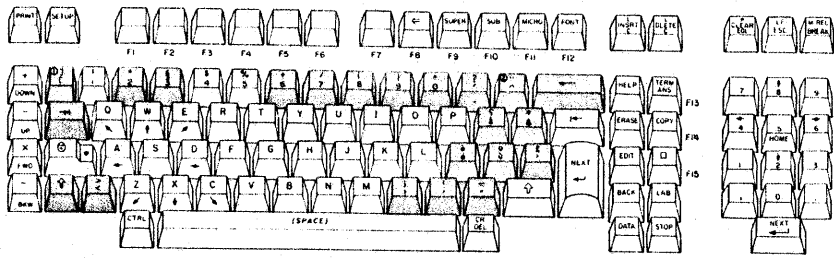

Ⓞ PROVIDED FOR PLATO USAGE
Ⓞ UPPER-UNLUT

Keyboard with French Keycaps

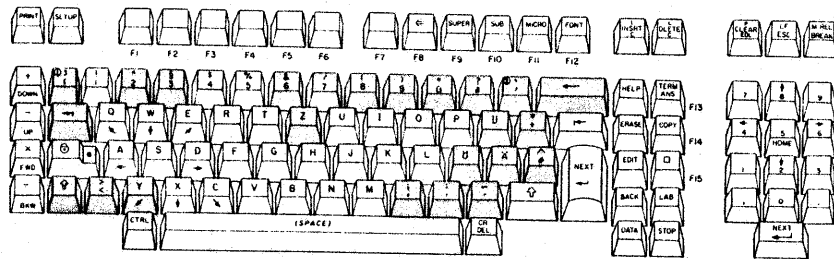

Ⓞ PROVIDED FOR PLATO USAGE
Ⓞ UPPER-OVER BAR
Ⓞ LOWER-UPPER GRAVE ACCENT

Keyboard with German Keycaps

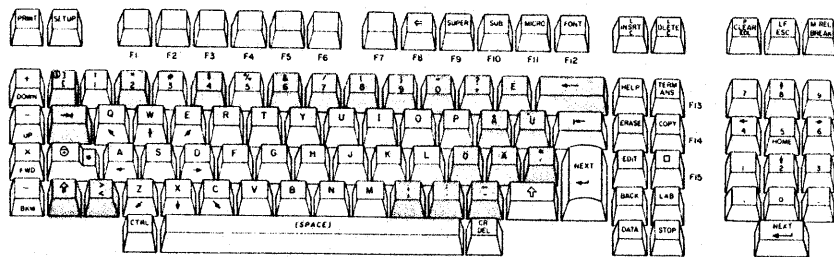

Ⓞ PROVIDED FOR PLATO USAGE

Keyboard with Swedish/Finnish Keycaps

NOTE:
OPTIONAL KEYCAPS ARE SHADED FOR ILLUSTRATING PURPOSES

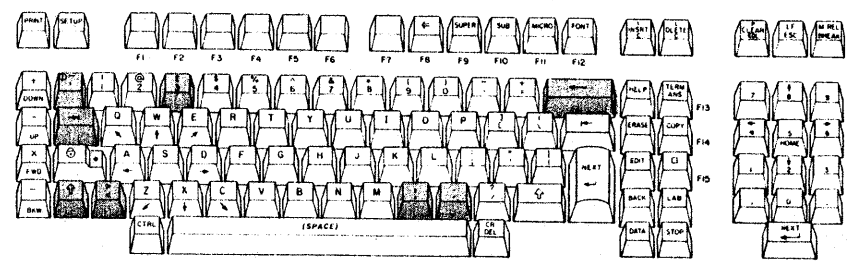

Ⓞ UPPER-OVER BAR
Ⓞ LOWER-GRAVE ACCENT

Keyboard with United Kingdom Keycaps

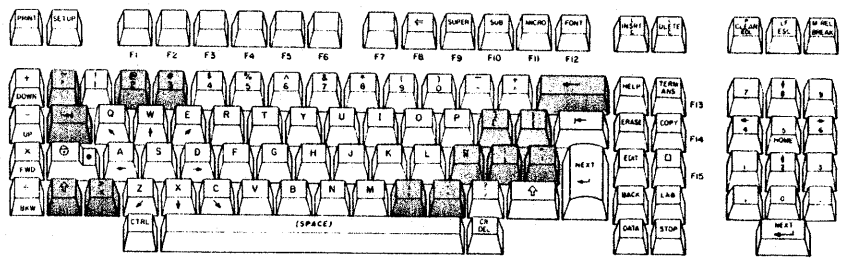

Ⓞ PROVIDED FOR PLATO USAGE

Keyboard with Spanish Keycaps

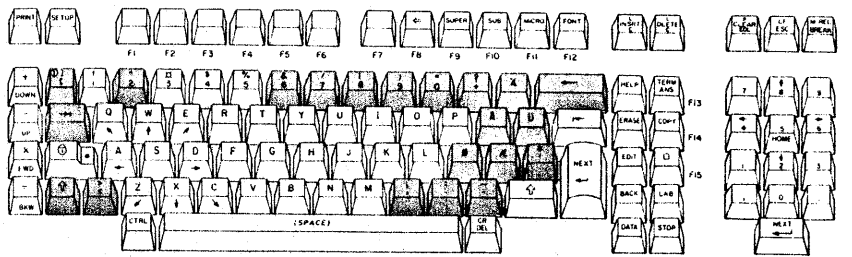

Ⓞ PROVIDED FOR PLATO USAGE

Keyboard with Danish/Norwegian Keycaps

Keyboard

The keyboard has the following characteristics in all operating modes. The Operating in CYBER Mode section gives details on the use of the keyboard in CYBER mode. Refer to your application program manuals for the use of the keyboard in other modes.

Typing on the keyboard is one way to "talk" to your terminal. You can type in commands (instructions) and data (information).

Keys on the keyboard can be divided into three groups:

- Data-entry keys for entering letters, numbers, symbols, and punctuation marks
- Control keys for editing data and moving the cursor
- Special keys for doing tasks that vary with your application program or operating mode, or with the computer your terminal may be linked to

Keys in the data-entry and control groups may be made typematic when your terminal is installed. Typematic keys start repeating when pressed for longer than a second. They stop repeating when you lift your finger off the key.

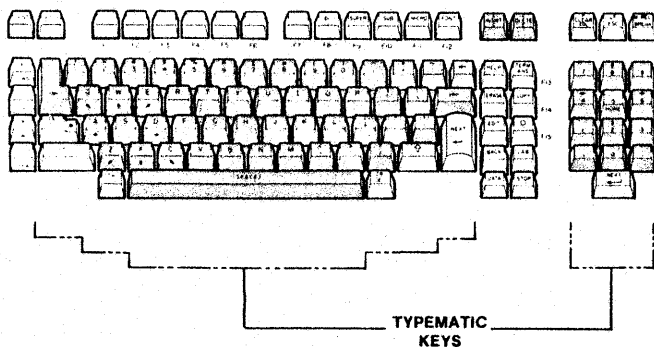

In some operating modes, the CTRL (Control) key may be pressed at the same time as other keys are pressed to alter the normal use of these keys.

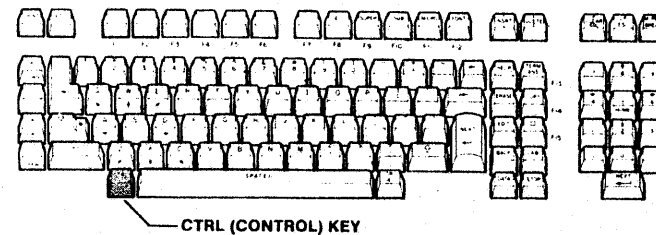

A SHIFT key  is located on each side of the main key grouping. The shift keys let you type uppercase (capitals).

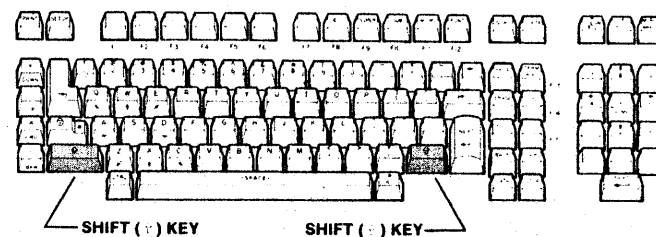

The LOCK key  may work as a normal shift lock or only allow letters to be typed in uppercase. When you press the LOCK key, the LOCK light on the key comes on and remains on until you press the LOCK key a second time to release the lock.

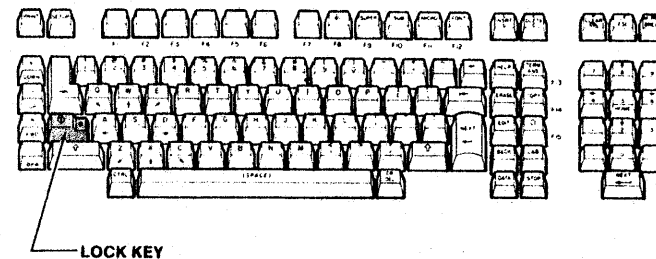

The keys in the numeric pad on the right side of the keyboard may operate in both uppercase and lowercase, or in uppercase only.

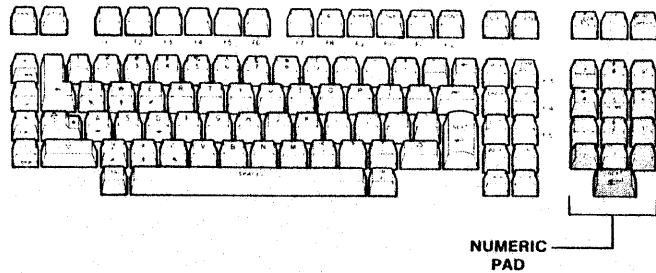

Changing Keyboard and Screen Angle

Now is a good time to try the adjustment features of your display terminal and keyboard.

You can change the angle of the screen by holding the terminal base and moving the display part of the terminal.

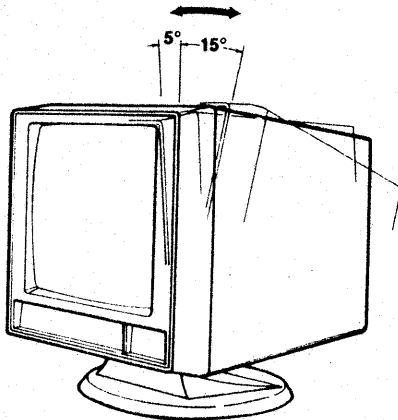

You can change the angle of the keyboard by moving its adjustable leg.

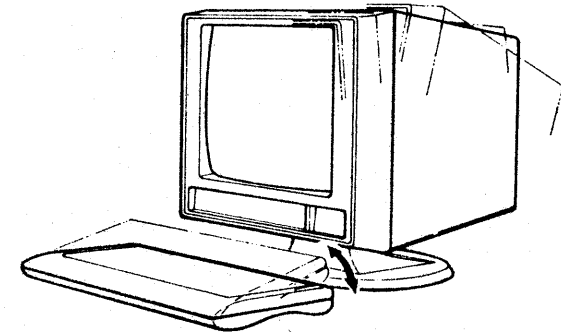

Mode Selection Display

The Mode Selection display appears when you turn on or reset the terminal (unless the terminal is set up for automatic selection of the operating mode). You have already used this display to select the **TERMINAL TEST** and find out if the terminal has a touchpanel. The Mode Selection display is also used to select the mode the terminal will be operating in:

- Mode 1 - CYBER
- Mode 2 - PLATO
- Mode 3 - CP/M
- Mode 4 - DISK
- Mode 5 - C120
- Mode 6 - This block may show a mode name or may remain blank
- Mode 7 - PACK
- **TERMINAL TEST**

NOTE: Modes 3, 4, and 5 may have been given new names during installation. If so, the new names will show in the block. Also, mode 7 is for factory use and is to be disregarded.

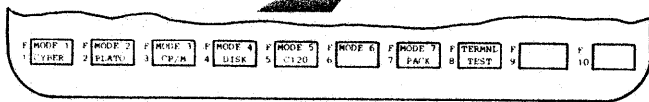
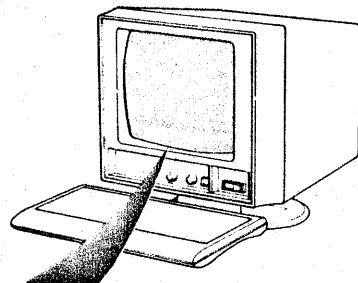

To select the mode the terminal will be operating in, press the F key with the same number as the mode you want to use. The F keys are on the top of the keyboard. The F key identifiers are below the keys, in raised lettering.

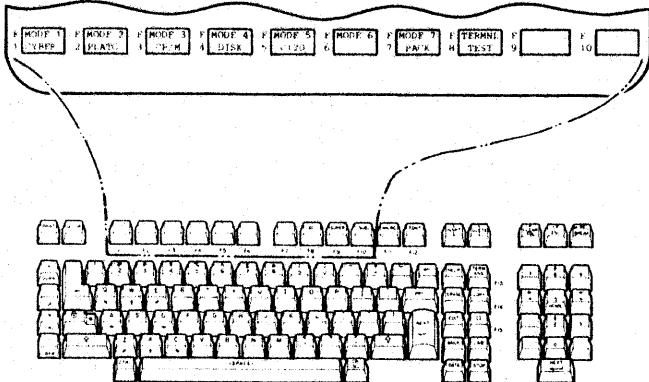

Using Modems

When a modem is used, the terminal can communicate over the telephone lines with a computer network or with another terminal. Just as you have to dial a telephone number to connect your phone to someone else's phone, a telephone number must be dialed to connect the terminal to a computer network or another terminal. This section describes how to call and connect to a network or a computer using the 1200/1200-baud internal modem or an external modem. Also described is how the auto-answer feature of the internal modem can be used to monitor the phone line and receive data.

NOTE: If your terminal is part of a CDC 110 Microcomputer System and the CP/M operating mode is used, phone numbers may be called by using the Phone Utility (program). The CP/M Phone Utility is described in the 110 System Owner's Manual.

Here is some general information about using modems:

- When you have connected to a network, you should see some message on the screen showing the connection has been made, such as a TERMINAL READY message, or a sign-on screen, or a message that the files are loaded. You may have to press NEXT, or type some character, such as an I and press NEXT before the sign-on screen appears. See the information you received from the network or computer service.
- When you are loading a file from a network or computer, the load may appear to complete almost instantly or may take up to 3 or 4 minutes to complete. During this time, information on the progress of the load appears on the screen. If the screen shows BLOCK 0 loading and NO REPLY appears, you may have entered an invalid file number or there may be a network problem. If this happens, press RESET, and try again.

- If you did not make a connection, one or both of these messages appear with the Mode Selection display:

HOST LOAD FAIL

FAILURE LOADING MODE

If these messages appear, press **RESET** and go back and try again. After several attempts to make a connection, if you do not get a connection message, or if a message remains on the screen indicating the connection has not been made, call the **HOTLINE** number you received from the network or computer service, or go to the Screen Messages section of the Problem Solving Guide.

- See your application manuals for how to sign on and how to sign off. Use the blank pages following this section to record the steps necessary for sign-on and sign-off.
- To disconnect from the network (be sure you have signed off before disconnecting), press **RESET**.

Internal Modem

You can find out if your terminal has an internal modem installed by looking at the I/F-4 location at the back of the terminal. If you have an internal modem, you will see a Canadian Department of Communications and FCC certification label.

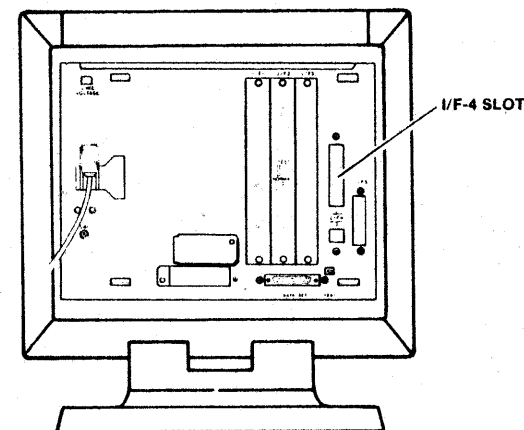

This section assumes the internal modem has been installed as described in the Installation Guide. Also assumed is that parameters have been set to select either the Manual, Combination, or Automatic Method for each mode where you will use the internal modem, as described in the Additional Parameters section of the Installation Guide.

To use the internal modem, the terminal must be turned on with the Mode Selection display appearing at the bottom of the screen. The terminal, through the modem, must now be connected to the network or computer by using the Manual, Combination, or Automatic Method.

If you don't know which method has been assigned to the mode you want to use, do the following:

- 1 Press the F key with the same number as the mode you want to use. For example, press the F1 key to choose mode 1, CYBER.

If the terminal "beeps" and FAILURE LOADING MODE appears on the screen, or if the screen goes dark for more than 30 seconds (except for a blinking cursor), the mode you chose either cannot be used or a problem has occurred. Reset the terminal. Find out the correct mode and repeat step 1. If FAILURE LOADING MODE appears again, or the screen again goes dark, go to the Screen Messages in the Problem Solving Guide.

If ENTER ACCESS CODE appears on the screen, type your assigned code. X's appear in the access code block as you type the code. If you type in the wrong code, SORRY and the Mode Selection display appear on the screen. Repeat step 1 if this happens.

- If the message PLEASE STANDBY (10 SECONDS MAX) appears, the mode is set to operate using the Manual Method.
- If the message ENTER PHONE NUMBER appears, the mode is set to operate using the Combination Method.
- If the message DIALING PHONE NUMBER appears, the mode is set to operate using the Automatic Method.

2 Press RESET.

The steps for dialing and connecting using the Manual, Combination, and Automatic Methods follow.

Manual Method

Use this procedure when an operating mode is set for the Manual Method:

- 1 Pick up the telephone handpiece and when you hear a dial tone, dial the phone number.
- 2 When you hear a high-pitched tone, press the F key for the mode you are using.
- 3 When the high-pitched tone stops and you hear a rushing sound, the connection has been made and you can hang up the telephone handpiece.

4 One of the following will happen:

- If you pressed the F1 (CYBER) or F5 (C120) keys, a message from the network or computer appears on the screen and you are connected.
- If you pressed the F2 (PLATO) key, the message SELECT LOAD SOURCE > DISK HOST ROM appears on the screen. Press the H key to select HOST (a computer network).

SELECT FILE NO. _____ then appears. Type the file number and press NEXT.

LOADING FILE followed by the file number and the BLOCK number appear. The file then loads.

- If one of the following messages appears, your phone call has not been completed. Press RESET and try again.

NO DIAL TONE
ILLEGAL DIGIT
DIALING ERROR
BUSY
NO ANSWER
HOST LOAD FAIL
FAILURE LOADING MODE

Combination Method

Use this procedure when an operating mode is set for the Combination Method:

- 1 Press the F key for the mode you are using.

- 2** ENTER PHONE NUMBER appears on the screen. Type the phone number on the keyboard.

The following characters can be used when typing a phone number:

0 to 9—to make standard phone number entries.

- B** —a substitute for the * character on tone-dial telephones. It should not be used on pulse-dial lines.
- C** —a substitute for the # character on tone-dial telephones. It should not be used on pulse-dial lines.
- D** —causes an auto-dialing sequence to pause until a tone is detected on the line. For example, it delays the dialing sequence to wait for a dial tone after dialing for an outside line.
- E** —causes an auto-dialing sequence to pause until no tone is detected on the line for 3 seconds. For example, it is used to insert a 3-second delay between a direct-dial access number and an area-code number, or between the area-code number and the actual telephone number.

- 3** Press NEXT.

- 4** One of the following will happen:

- If you pressed the F1 (CYBER) key, a message from the network appears on the screen.
- If you pressed the F2 (PLATO) key, the message SELECT LOAD SOURCE > DISK HOST ROM appears on the screen. Press the H key to select HOST (a computer network).

SELECT FILE NO. _____ then appears. Type the file number and press NEXT.

LOADING FILE followed by the file number and the BLOCK number appear. The file then loads.

- If you pressed the F5 (C120) key, the message SELECT LOAD SOURCE > DISK HOST ROM appears on the screen. Press the R key to select ROM (the C120 computer) and then press the NEXT key. A message from the C120 computer appears on the screen. (If you don't press the NEXT key you will get a TOO SLOW - DISCONNECTING message. If you do, reset and start over.)
- If one of the following messages appears, your phone call has not been completed. Press RESET and try again.

NO DIAL TONE
ILLEGAL DIGIT
DIALING ERROR
BUSY
NO ANSWER
HOST LOAD FAIL
FAILURE LOADING MODE

Automatic Method

Use this procedure when an operating mode is set for the Automatic Method:

- 1** Press the F key for the mode you are using. One of the following will happen:

- If you pressed the F1 (CYBER) key, a message from the network appears on the screen.
- If you pressed the F5 (C120) key, a message from the C120 computer appears on the screen.
- If you pressed the F2 (PLATO) key, a LOADING FILE message followed by the file number and the BLOCK number appears on the screen, and the file loads.

NOTE: The file number set at the factory (the default file number) is 08, set in the first two positions of the PLATO F9 mode installation parameter block. If this file number has been changed, the file will not load properly.

- If one of the following messages appears, your phone call has not been completed. Press RESET and try again.

NO DIAL TONE
 ILLEGAL DIGIT
 DIALING ERROR
 BUSY
 NO ANSWER
 HOST LOAD FAIL
 FAILURE LOADING MODE

Auto-Answer Mode

Auto-answer mode places the terminal in an inactive state where it waits for telephone line activity. For example, auto-answer mode may be used so the terminal can receive a nightly report without anyone being present. The terminal may store the report on the screen or print the report on a connected printer. Other uses of auto-answer will depend on your application.

In auto-answer mode, the internal modem monitors the telephone line for two rings from the remote computer. When this occurs, the terminal automatically answers and goes online to the computer.

Follow these steps to place the terminal in auto-answer mode:

NOTE: If you are operating with the internal modem using the Manual Method in CYBER mode, skip to step 8.

- 1 With the Mode Selection display on the screen, while pressing the CTRL key, press the SETUP key.
- 2 Press the F10 key.
- 3 When ENTER MODE n (1-6) appears, press the 1 key and the CYBER mode installation parameters appear.
- 4 Press the F3 key and then the space key.
- 5 Press the 0 key to change F3, position 2 to a 0.
- 6 Press the COPY key.

- 7 Press the F1 key.
- 8 With the Mode Selection display on the screen, press the F1 key to enter CYBER mode. Entry into CYBER mode is successful if the PLEASE STANDBY (10 SECONDS MAX) message appears. Then the screen clears, and the cursor resets to the upper- or lower-left corner of the screen.
- 9 Press the SETUP key.

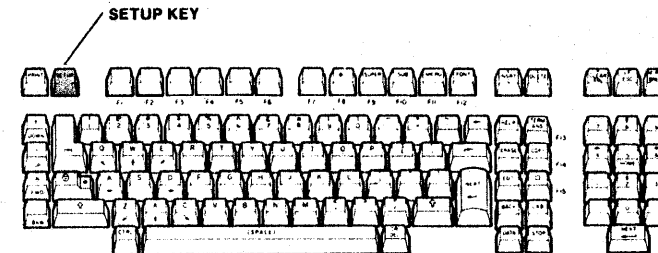

- 10 Press the F2 key as often as necessary until ANSWER appears in the F2 block on the screen.

F	LINE
2	(ANSWER)

- 11 Return to CYBER mode by pressing the F1 key. Your terminal then enters auto-answer mode and the message WAITING TO ANSWER appears on the last line of the screen.
- 12 To return to CYBER mode, press the M REL/BREAK key. (In auto-answer mode, the keyboard is locked except for the M REL/BREAK key.) To return to the Mode Selection display, press the SETUP key and then the F10 key twice.
- 13 When you are through using the auto-answer feature, and if you changed the F3 mode installation parameter block position 2 to a 0, repeat steps 1 through 7, but at step 5 press the 1 key to change the 0 to a 1.

External Modems

This section assumes an external modem has been installed as described in the Installation Guide and that the terminal is turned on with the Mode Selection display appearing at the bottom of the screen. The terminal, through the modem, must now be connected to the network or computer you will use by dialing the phone number. The steps for dialing and connecting the UDS 212LP modem, the Racal-Vadic VA3451 modem, the Bell 212A modem, and the Multi-Tech 212A modem follow:

- 1 Press the F key with the same number as the mode you want to use. For example, press the F1 key to choose mode 1, CYBER.
- 2 If the terminal "beeps" and FAILURE LOADING MODE appears on the screen, the mode you chose either cannot be used or a problem has occurred. Find out the correct mode and repeat step 1. If FAILURE LOADING MODE appears again, go to the Screen Messages in the Problem Solving Guide.
- 3 If ENTER ACCESS CODE appears on the screen, type your assigned code. X's appear in the access code block as you type the code. If you type in the wrong code, SORRY and the Mode Selection display appear on the screen. Repeat step 1 if this happens.
- 4 If SELECT LOAD SOURCE > DISK HOST ROM appears, press the H key and if necessary, press NEXT.
- 5 If HOST NOT CONNECTED appears on the screen, dial the network or computer telephone number. The message will remain on the screen for 40 seconds, enough time for you to dial the telephone number.
- 6 One of the following will happen:
 - If you have a UDS 212LP modem, when you hear a high-pitched confirmation tone, switch the DATA/TALK switch to DATA. The red carrier indicator should light.

- If you have a Racal-Vadic VA3451 modem, check that the HS, DSR, and DTR lights are on. When you hear the high-pitched confirmation tone, switch the DA/VO switch to DA.
 - If you have a Bell 212A modem, check that the HS switch is pushed in. When you hear the high-pitched confirmation tone, press the DATA button on the telephone.
 - If you have a Multi-Tech MT 212A modem, after the phone rings once, push in the VOICE DATA button. (You must push the VOICE DATA button before you receive the high-pitched confirmation tone. If you do not do so, you may not gain connection to the network.)
- 7 Hang up the telephone.
 - 8 Check the following:
 - If you have a Racal-Vadic VA3451 modem, the HS, CTS, DSR, DTR, and CXR lights are on. (The TXD light will flash when transmitting and the RXD light will flash when receiving.)
 - If you have a Bell 212A modem, the MC light is off and the MR and HS lights are on. (The SD light will flash when transmitting and the RD will flash when receiving.)
 - If you have a Multi-Tech 212A modem, the CO, CTS, HS, OH, and DTR lights are on.
 - 9 If SELECT FILE NO. _____ appears on the screen, press NEXT to select the file number that was preselected at installation, or type the file number of the file you want to use and press NEXT. If you make a mistake, use the ERASE key to erase the mistake and then retype the number.

- 10** Depending on your application, a load may be completed almost instantly or may take up to 3 or 4 minutes to complete. Information on the progress of the load may appear on the screen. If the screen shows **BLOCK 0** loading and **NO REPLY** appears, you may have entered an invalid file number, or there may be a network problem. If this happens, press **RESET**, go back to step 1, and try again.
- 11** When you have connected to the network, you should see a message on the screen showing the connection has been made, such as a **TERMINAL READY** message or a sign-on screen. When the connection has been made, you may have to press **NEXT**, or type some character, such as an **l**, and press **NEXT** before the sign-on screen appears. See the information you received from the network or computer service.

If you did not make a connection, both of these messages appear with the Mode Selection display:

HOST LOAD FAIL

FAILURE LOADING MODE

If these messages appear, press **RESET** and go back to step 1. After several attempts to make a connection, if you do not get a connection message, or if a message remains on the screen indicating the connection has not been made, call the **HOTLINE** number you received from the network or computer service, or go to the **Screen Messages** section of the **Problem Solving Guide**.

- 12** See your application manuals for how to sign on and how to sign off. Use the blank pages following this section to record the steps necessary for sign-on and sign-off.
- 13** To disconnect from the network (be sure you have signed off before disconnecting):
- If you have a UDS 212LP modem, when you are finished using the network or computer service, push the **DATA/TALK** switch to **TALK** to obtain the dial tone.

- If you have a Racal-Vadic VA3451 modem, switch the **DA/VO** switch to **VO** when you are finished using the network or computer service.
- If you have a Bell 212A modem, the modem automatically disconnects when you sign off.
- If you have a Multi-Tech MT 212A modem, flip the **OOS/ANLB** switch to the right and then to the left.

Sign-On Information

_____	NETWORK/COMPUTER
_____	F KEY
_____	TELEPHONE NUMBER
_____	FILE NUMBER
_____	_____
_____	_____
_____	_____
_____	SIGN OFF
_____	HOTLINE NUMBER
_____	_____
_____	NETWORK/COMPUTER
_____	F KEY
_____	TELEPHONE NUMBER
_____	FILE NUMBER
_____	_____
_____	_____
_____	_____
_____	SIGN OFF
_____	HOTLINE NUMBER

Sign-On Information

_____	NETWORK/COMPUTER
_____	F KEY
_____	TELEPHONE NUMBER
_____	FILE NUMBER
_____	_____
_____	_____
_____	_____
_____	SIGN OFF
_____	HOTLINE NUMBER
_____	_____
_____	NETWORK/COMPUTER
_____	F KEY
_____	TELEPHONE NUMBER
_____	FILE NUMBER
_____	_____
_____	_____
_____	_____
_____	SIGN OFF
_____	HOTLINE NUMBER

Using a Flexible-Disk Drive

A flexible-disk drive may be connected to the terminal.
This is a primary flexible-disk drive:

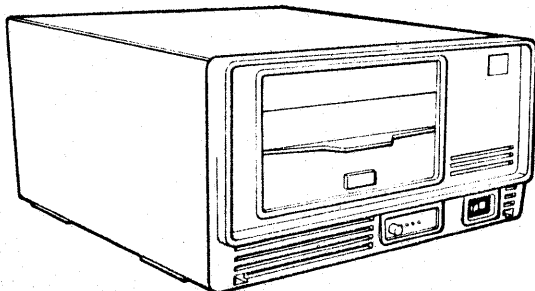

You may also have a secondary flexible-disk drive. It looks like the primary unit, but does not have a RESET switch or lights:

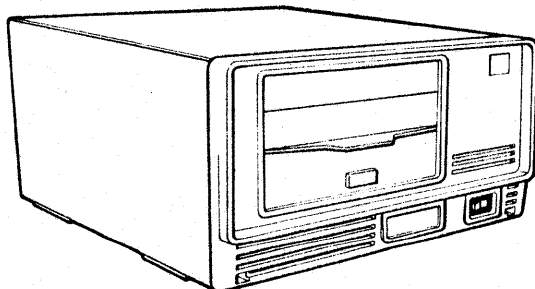

Flexible disks are used to store programs and information:

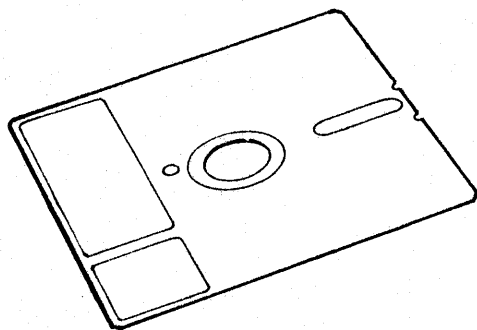

This section assumes a flexible-disk drive is connected to the terminal and that the terminal is turned on with the Mode Selection display appearing at the bottom of the screen. The steps for loading a program into the terminal's memory follow:

- 1 Turn on the primary flexible-disk drive or reset it if it is already on. The red POWER light on the front of the drive should come on when you turn on the unit.

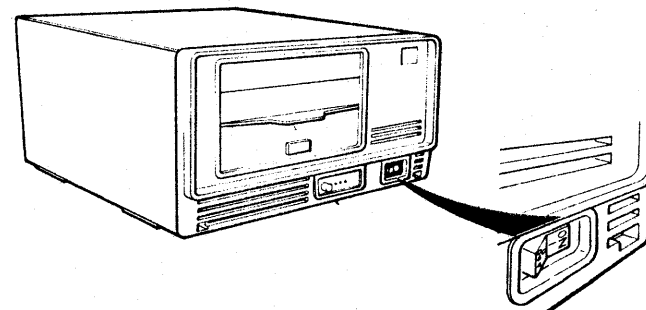

NOTE: Do not insert a flexible disk into the disk drive if power is off. Doing this may damage the flexible disk.

- 2 Open the access door of the flexible-disk drive by pressing the pushbar on the front of the unit.

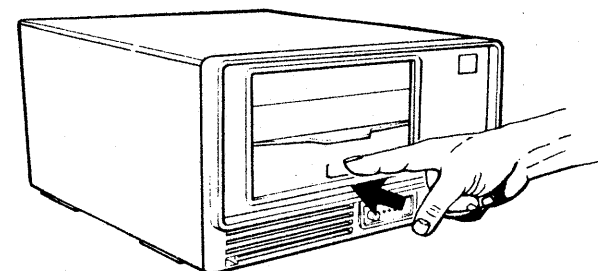

- 3** Remove the flexible disk from its storage envelope.

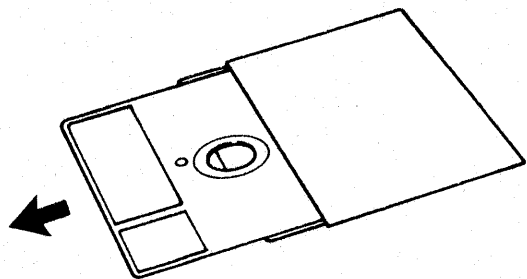

- 4** Hold the flexible disk so the label side is up and slide the disk into the drive.

CAUTION: The POWER light on the front of the drive must be lit before inserting the disk into the drive.

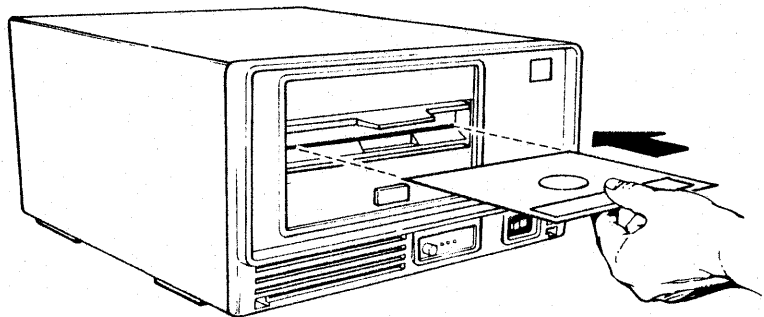

- 5** Close the drive access door by pressing down on the lip of the door until the door latches. The READ light on the front of the drive should come on and then go off. (The POWER light should stay on.)

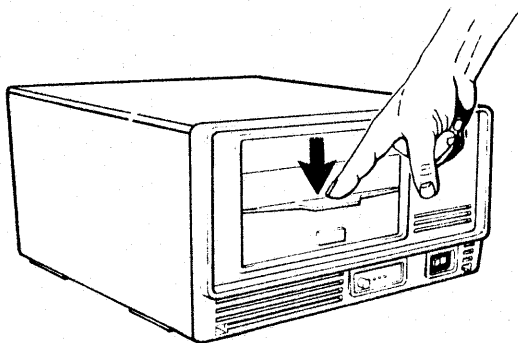

- 6** Load the program (or information) on the flexible disk into the terminal's memory by pressing the F key with the same number as the mode you want to use. For example, to load the CP/M operating program, use the F3 (CP/M mode) key or use the F key directed by your application program.

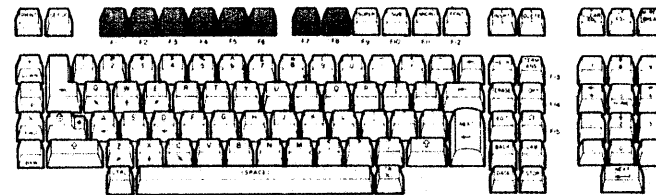

- 7** If the terminal "beeps" and FAILURE LOADING MODE appears on the screen, the mode you chose either cannot be used or a problem has occurred. Find out the correct mode and repeat step 6. If the message appears again, go to the Screen Messages in the Problem Solving Guide.

- 8** If SELECT LOAD SOURCE > DISK HOST ROM appears on the screen, select the source from which the program is loaded by:

- Pressing the NEXT key (if DISK was preselected at installation)
- Pressing the D key for DISK

- 9** When loading is complete, a message appears on the display screen. What the message says depends upon the program that was loaded.

If loading is not successful, both of these messages appear with the Mode Selection display:

DISK LOAD FAIL
FAILURE LOADING MODE

If these messages appear, press RESET and go back to step 1. If the messages appear again, go to the Screen Messages in the Problem Solving Guide.

- 10** See your application program manuals for operating instructions.

Using a Memory Module

This section assumes the memory module has been installed as described in the Installation Guide and that the terminal is turned on with the Mode Selection display appearing at the bottom of the screen. The steps for loading a program into the terminal's memory follow:

- 1 Press the F key with the same number as the mode you want to use. (Mode 6 is the standard mode used for a memory module; your memory module may use a different mode.)

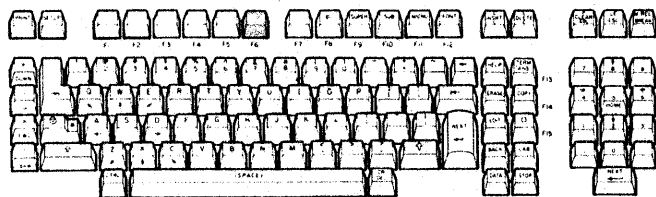

- 2 If the terminal "beeps" and FAILURE LOADING MODE appears on the screen, the mode you chose either cannot be used or a problem has occurred. Find out the correct mode and repeat step 1. If FAILURE LOADING MODE appears again, go to the Screen Messages in the Problem Solving Guide.
- 3 If SELECT LOAD SOURCE > DISK HOST ROM appears on the screen, select the source from which the program is loaded by:
 - Pressing the NEXT key (if ROM was preselected at installation)
 - Pressing the R key for ROM

- 4 When loading is complete, a new display appears on the screen. The display depends upon the program that was loaded. The load takes less than a second to complete.

If loading is not successful, FAILURE LOADING MODE appears with the Mode Selection display.

If this message appears, press RESET. Go back to step 1 and try again. If the message appears again, go to the Screen Messages in the Problem Solving Guide.

- 5 See your application program manuals for operating instructions.

Changing Parameters

Parameters are information the terminal needs to know in order to operate properly. Examples are:

- Does your terminal have a graphics printer connected?
- Does your terminal have a serial-interface board installed?
- Does your terminal have a flexible-disk drive connected?

This type of information is stored in the terminal's non-volatile memory. Non-volatile memory (NVM) is the terminal memory that stays active even when the terminal is turned off (a battery installed in the terminal keeps the memory active).

NOTE: The battery inside the terminal will eventually become weak. When this happens, a BATTERY LOW message will appear on the screen after a power on or reset, and the battery will have to be replaced. Instructions for battery replacement are given in the Screen Messages section of the Problem Solving Guide.

NOTE: If the battery is removed while the terminal is turned off, you will have to re-enter the parameters as shown in the Parameter Record in the Installation section.

Adding additional items to the terminal, operating with certain application programs, or making other changes may require changes to the parameters.

There are two types of installation parameters: terminal installation parameters and mode installation parameters. The Parameter Settings section in the Installation Guide gives more detailed information about parameters.

Follow these steps to change parameters:

1 If the Mode Selection display is on the screen, press and hold the CTRL key while pressing the SETUP key.

If the Mode Selection display is not on the screen:

- If the terminal is in CYBER mode, press the SETUP key. Then press the F10 key twice.
- If the terminal is not in CYBER mode, and you are able to select your operating mode, press RESET. The Mode Selection display appears on the screen. Press and hold the CTRL key while pressing the SETUP key.
- If the terminal is not in CYBER mode, and is set up for automatic selection of the operating mode, pull out the TEST switch at the back of the terminal. Then press the RESET switch at the front of the terminal. Disregard the TEST SWITCH ENABLED message that appears with the Mode Selection display. Push the TEST switch back in. Press and hold the CTRL key while pressing the SETUP key.

2 The terminal installation parameters appear in a row of lighted blocks at the bottom of the screen. A typical display is shown:

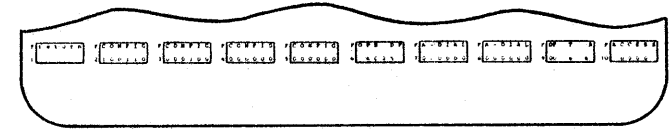

(TYPICAL)

3 To the left of each block is the letter F with a number below it. These F numbers relate the blocks to the F key with the same number.

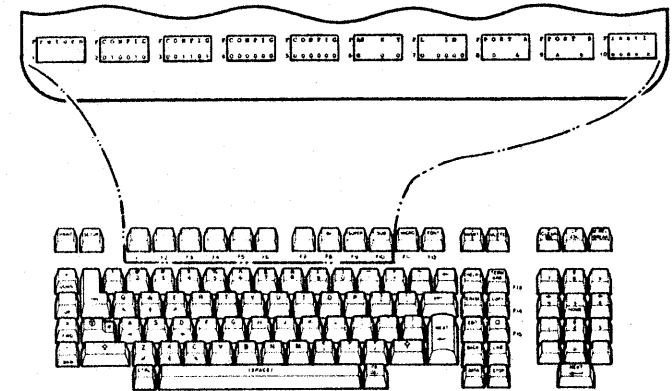

The cursor appears in the F2 block. This is a typical F2 block. Yours may be different.



NOTE: Only certain keys work when changing parameters. The cursor may be moved forward with the space bar or backward with the backspace key (←). Pressing an F key will move the cursor to the first position of the block with the same F number as the key. Do not press the F1 or F10 key at this time.

- 4 Move the cursor to the desired F block and then to the desired position within the block. (If you do not want to change any terminal installation parameters but you do want to change mode installation parameters, press the F10 key and skip to step 7.)
- 5 Make your required terminal installation parameter entries. Recheck all your entries. Then press the COPY key to enter the changes in the non-volatile memory. Record any changes in the Parameter Record in the Installation section.

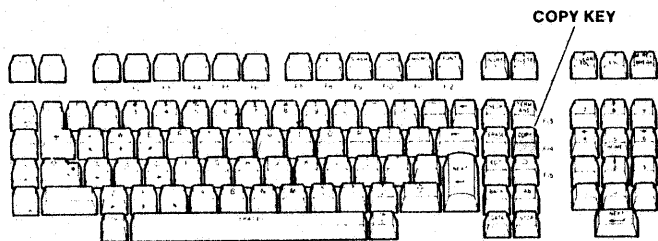

- 6 When your entries have been checked and recorded, press the F10 key.

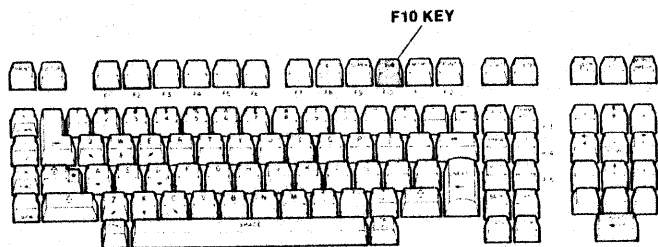

- 7 The screen then displays:

ENTER MODE n (1-6)

Type the number of the mode you want to change.

- 8 If you typed a 1 or 2, skip this step. If you typed a 3, 4, 5, or 6, the screen displays:

ENTER MODE NAME

The preassigned mode name appears in the boxes. Press NEXT.

- 9 The mode installation parameters for the selected mode appear on the screen. Use the F keys, space bar, and backspace key to move the cursor to the parameters you want to change and make the changes.
- 10 Recheck all your entries. Then press the COPY key to enter the changes in the non-volatile memory. Record any changes in the Parameter Record in the Installation section.
- 11 Press the F1 key to put the Mode Selection display on the screen and return to normal operation.

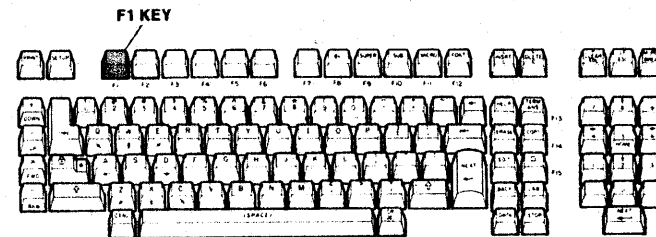

Operating in CYBER Mode

The following pages describe the operation of your terminal in CYBER mode. Refer to your application program manuals for information on operating in modes other than CYBER.

Operator Parameters

Parameters are guidelines the terminal needs to have to operate properly. These guidelines are set when your terminal is installed. Operator parameters let you or your host computer temporarily change certain guidelines. These changes remain in effect until you press RESET or turn off the terminal.

NOTE: You can change all operator parameters except characters per line (CHR/LN) or lines per display (LINES) without clearing any data displayed on the screen. Changing the CHR/LN or LINES parameter clears all data displayed on the screen at the time the change is made.

Follow these steps to display/change operator parameters:

- 1 If the terminal is not in CYBER mode, press the F1 key to enter CYBER mode. Entry into CYBER mode is successful if the screen clears and the cursor resets to the home position (upper- or lower-left corner of the screen).

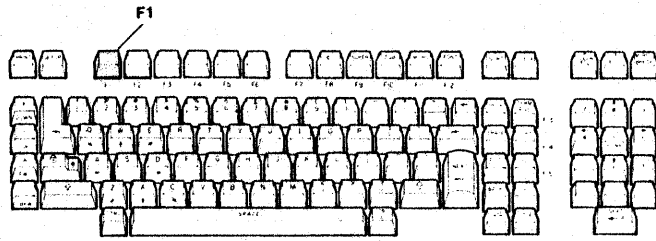

- 2 Press the SETUP key.

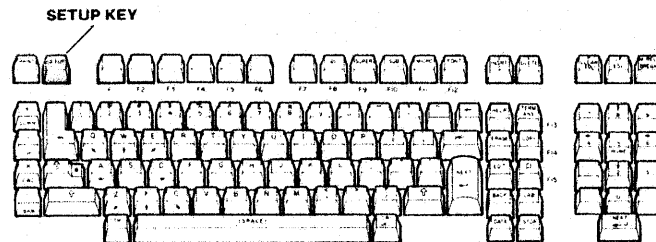

- 3 A display of the first set of operator parameters temporarily replaces any data on the last two lines of the screen.

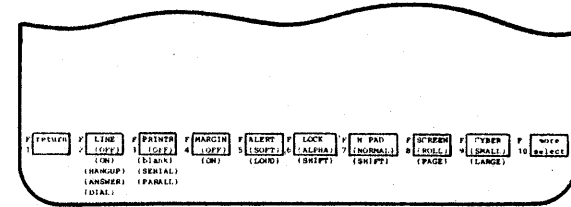

NOTE: Alternate selections are shown below the boxes. These selections do not appear on the screen.

- 4 The parameter choices now in effect appear within the blocks on the screen. To change a parameter, press the F key with the same number as the parameter, you wish to change. This puts the alternate choice in effect. If more than two choices are available, press the F key as often as necessary to step to the desired choice. For example, if block F4 shows MARGIN (OFF), press the F4 key to change the parameter to MARGIN (ON).



The following is a description of the first set of operator parameters for CYBER mode:

F 2 LINE (OFF)
(ON)
(HANGUP)
(ANSWER)
(DIAL)

- OFF places the terminal offline with your host computer to do local printing or testing (CYBER-Mode Test).
- ON places the terminal online with your host computer.
- If an internal modem is installed, HANGUP breaks the telephone connection with your host computer.

- If an internal modem is installed, ANSWER displays WAITING TO ANSWER on the last line of the screen and places the terminal in auto-answer mode.
- If an internal modem is installed, DIAL dials the phone number stored in memory or lets you enter a phone number on the keyboard. If connection to a network or computer has been interrupted, use DIAL to reconnect without reloading.

F 3 **PRINTER**
(OFF)
(SERIAL)
(PARALL)
(blank)

- OFF stops printing.
- SERIAL sends online data to a serial printer.
- PARALL sends online data to a parallel printer.
- If no printer is installed, this field remains blank and no changes can be made to it.

F 4 **MARGIN**
(OFF)
(ON)

- ON sounds the terminal alarm (a beep) when entries on the keyboard move the cursor to the eighth position from the end of a line or to the last line on the screen.

F 5 **ALERT**
(SOFT)
(LOUD)

- SOFT makes the terminal alarm beep softly.
- LOUD makes the terminal alarm beep loudly.

F 6 **LOCK**
(ALPHA)
(SHIFT)

- SHIFT causes the LOCK key to work as a normal shift lock.
- ALPHA causes the LOCK key to limit only letters to uppercase (capitals).

F 7 **NPAD**
(NORMAL)
(SHIFT)

- NORMAL lets the keys in the numeric pad (on the right side of the keyboard) operate in either lowercase or uppercase.
- SHIFT makes the keys in the numeric pad operate only in uppercase as if a SHIFT key (⇧) is used.

F 8 **SCREEN**
(ROLL)
(PAGE)

- ROLL causes the display on the screen to roll up one line when the cursor moves beyond the last line.

F 9 **CYBER**
(SMALL)
(LARGE)

- PAGE causes the cursor to reset to the home position (in CYBER mode, the upper-left corner of the screen) when the cursor moves beyond the last line.
- SMALL lets the terminal operate with CDC CYBER 120 series computer systems.
- LARGE lets the terminal operate with CDC CYBER 170 series computer systems.

5 Press the F10 key to display the second set of operator parameters.

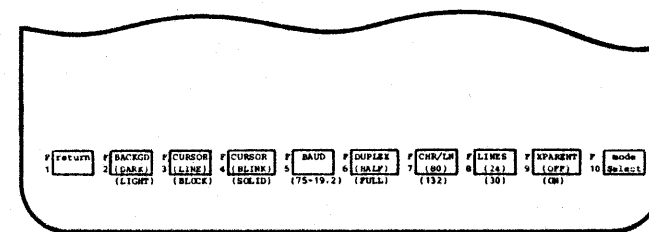

The following is a description of the second set of operator parameters for CYBER mode:

F 2 **BACKGD**
(DARK)
(LIGHT)

- DARK makes the screen display light characters on a dark background.
- LIGHT makes the screen display dark characters on a light background.

F 3 **CURSOR**
(LINE)
(BLOCK)

- LINE makes the cursor appear as an underline.
- BLOCK makes the cursor appear as a block.

F 4 **CURSOR**
(BLINK)
(SOLID)

- BLINK shows the cursor as blinking.
- SOLID shows the cursor as steadily lit.

- F 5 **BAUD**
(75-19.2)
- This block controls the data rate (baud rate) used in communications with your host computer. The baud rate selected should be the same as the baud rate used by your modem. Press the F5 key as often as necessary to step to the desired baud rate. (If the terminal has an internal modem installed, select 1200.)
- F 6 **DUPLEX (HALF)**
(FULL)
- HALF displays keyboard entries on the screen at the same time as they are transmitted (half-duplex routing).
 - FULL displays keyboard entries after they are echoed back by your host computer (full-duplex routing).
- F 7 **CH/LN**
(80)
(132)
- 80 displays 80 characters maximum per line.
 - 132 displays 132 characters maximum per line.
- F 8 **LINES**
(24)
(30)
- 24 displays 24 lines per screen.
 - 30 displays 30 lines per screen.
- F 9 **XPARENT (OFF)**
(ON)
- ON lets you use a test feature that displays received and keyboard-entered control codes on the screen instead of performing the usual tasks governed by these codes.
 - OFF allows normal operations.

6 To return to CYBER mode, press the F1 key. To put the Mode Selection display on the screen, press the F10 key.

Protected Screen Positions

Any character position on the display screen may be "protected" by your host computer. Protected screen positions help to reduce mistakes in data-entry as data in a protected position can only be changed by your host computer. If you try to erase, move, or enter data in a protected position, the terminal "beeps."

You can usually identify a protected screen position by the highlighting used. Data in a protected position may be:

- Dimmed
- Underlined
- Blinking
- In inverse video (dark characters on a light background)
- Any combination of these

Your host computer may place the terminal in protection mode with or without automatic tabbing. If the terminal is operating in protection mode without automatic tabbing:

- You can move the cursor up, down, or sideways into a protected screen position.
- You cannot erase, move, or enter data in a protected screen position.

If the terminal is operating in protection mode with automatic tabbing:

- You can move the cursor up or down into a protected position.

- You cannot move the cursor sideways into a protected position. The cursor will automatically tab through the protected position to the next unprotected position.
- You cannot erase, move, or enter data in a protected position. Trying to enter data in a protected position automatically tabs the data to the next unprotected position.

Character/Block Transmit Modes

In CYBER mode, data may be sent from the terminal to your host computer:

- One character at a time (character-transmit)
- As a block of characters (block-transmit)

Character-Transmit Mode

The terminal sends data to your host computer one character at a time as it is entered on the keyboard. When you press a key, the key's character is immediately sent to the computer.

Block-Transmit Mode

Your host computer can tell the terminal to enter block-transmit mode. In this mode, keyboard entries are stored for later transmission. The screen may be filled and edited before transmission unless:

- You press a shift key at the same time as the L INSRT C (Insert-Line/Insert-Character) key. The code for this key is immediately transmitted and nothing happens until your host sends back the code for the key.
- You press a shift key at the same time as the L DELETE C (Delete-Line/Delete-Character) key. The code for this is immediately transmitted and nothing happens until your host sends back the code for the key.

The key to be used to start a block-transmission varies with your host computer and application. During a block transmission, the keyboard locks and the LOCK indicator lights. The cursor moves through the data on the screen as it is transmitted. Depending on the instructions from your host computer, data is transmitted:

- Until all unprotected data on the screen is sent up to the position the cursor occupied before transmission
- Until all unprotected data on the screen is sent

When the transmission is complete, the cursor returns to the position it occupied before transmission.

Block-transmit mode remains in effect until your host computer makes a change. In some applications, the computer may let you make the change by pressing a Shift (↑) key at the same time as the P/CLEAR/EOL key. Pressing these keys clears all data displayed on the screen (including protected positions).

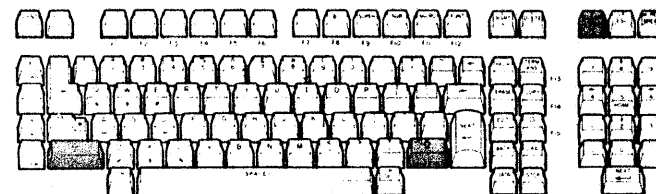

Keyboard

In CYBER mode, your host computer may change the way certain keys work. Other keys may not work at all unless the computer has selected a use for them.

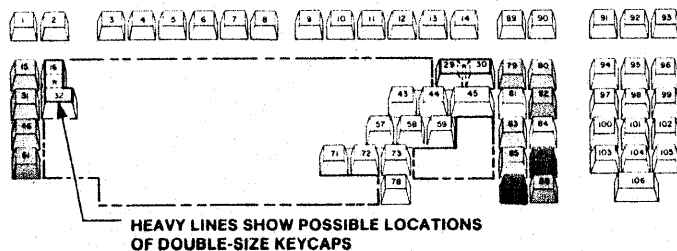

- Your host computer may change the way these keys work.
- These keys only work if your host computer selects a use for them.
- These keys do not work unless your host computer selects a use for them. However, these keys do work when used with the CTRL (Control) key.

The highlighted keys work as described in the following pages unless your host computer has made a change.

Keys on the keyboard may be grouped according to the jobs they do:

- Moving the cursor
- Tabbing
- Editing
- Altering keyboard entries
- Controlling communications and printing
- Entering special characters

NOTE: The terminal may be operating in protection mode with or without automatic tabbing (described in Protected Screen Positions). Automatic tabbing may affect the way certain keys work.

Moving the Cursor

Press

Left one position

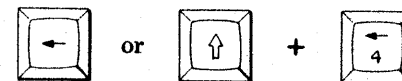

Right one position

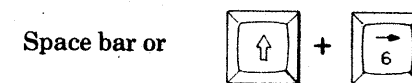

Up one line in the same column

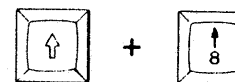

Down one line in the same column

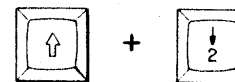

If your terminal is set up for automatic line feed, to the first position of the next line. If automatic line feed is not in effect, to the first position of the present line.

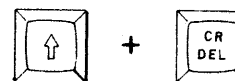

In large CYBER operations with automatic line feed, to the first position of the next line. In large CYBER operations without automatic line feed, to the first position of the present line.



In small CYBER operations, to the first position of the next line.



To the home position (lower- or upper-left corner of the screen).

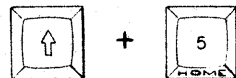

Tabbing

Sets the column containing cursor as a tab stop.

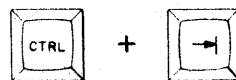

Clears the tab stop from the column containing cursor.

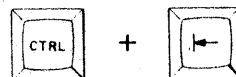

Tabs forward to the next tab stop. If no tab stop is present, the cursor returns to the upper-left position.



Tabs backward to the next tab stop. If no tab stop is present, the cursor returns to the upper-left position.



Editing

Erases unprotected data on the screen from the cursor position forward to the end of the line.



Erases all unprotected data on the screen and moves the cursor to the home position. Your host computer may let this key erase protected positions and switch communications from block-transmit mode to character-transmit mode.

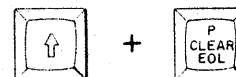

Press

Press

In small CYBER operations, erases present line forward and backward to beginning and end of line. The cursor moves back to the beginning of the line.



In large CYBER operations, backspaces the cursor and erases the new position.



Erases the character at the cursor position and shifts any characters to the right of the cursor one position to the left.



Erases any characters on the line and shifts lower lines up one line.

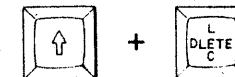

Shifts the character at the cursor position right and inserts a space in the cursor position.



Shifts line down one line and inserts a line of spaces.

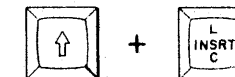

Sends a delete code. The use of a delete code depends upon your application.



Altering Keyboard Entries

Pressing a SHIFT key (⇧) at the same time as an alphanumeric (letters, numbers, or symbols) key allows you to type in uppercase or use the control function (upper symbol) of the key.



The LOCK key on your terminal may be set up to work as a normal shift lock or limit only letters to uppercase.

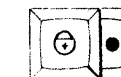

The CTRL (control) key is pressed at the same time as other keys are pressed to produce special code sequences. The use of the CTRL key depends on your host computer and application program.



Controlling Communications and Printing

Does a manual release, stopping all communications and print transfers to your host computer. Unlocks the keyboard if it is locked.

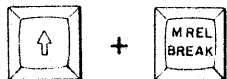

If allowed by your host computer, changes mode of communications from block-transmit to character-transmit.

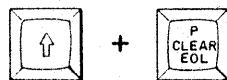

Sends to your printer all data displayed on the screen from top of page to end of page. Control and command codes are replaced with spaces. A carriage return and line feed is inserted as printing begins and at the end of each line. The keyboard locks, and the LOCK indicator lights. Any data received by the terminal is temporarily ignored.



Same as preceding, except dimmed data is replaced with space codes.

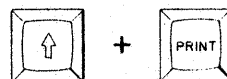

Sends a break signal that unlocks the keyboard and breaks communication with your host computer. Stops continuous dialing of the internal modem.



Sends an escape code. The use of an escape code depends upon your application.



Press

Entering Special Characters

In CYBER mode, your host computer may tell the terminal to display special characters instead of the characters shown on the keys. The special characters include:

- Line-drawing characters that display in place of punctuation and numeric characters
- Symbols that display in place of alphabetic characters
- Symbols that display in place of alphabetic characters and vary with your host computer

LINE DRAWING CHARACTERS

SYMBOLS

COLUMN A CONVENTIONAL ENTRY FOR ALL KEYCAP SETS UNLESS OTHERWISE NOTED		COLUMN B CORRESPONDING LINE-DRAWING SYMBOL	
A	B	A	B
(Space)	—	0	⌋
!		1	⌋
"	┌	2	⌋
£ (British or Spanish or French keycaps)	┌	3	⌋
# (Other keycap sets)		4	⌋
\$	┌	5	⌋
¤ (Swedish/Finnish keycaps)		6	⌋
§	┌	7	⌋
&	┌	8	⌋
' (Apostrophe)	┌	9	⌋
(┌	: (Colon)	⌋
)	┌	; (Semicolon)	⌋
*	┌	<	■
+ (Plus)	=	=	■
,		>	(Space)
- (Minus)	┌	?	■
. (Decimal Point)	┌		
/	┌		

COLUMN A CONVENTIONAL ENTRY FOR ALL KEYCAP SETS UNLESS OTHERWISE NOTED		COLUMN B CORRESPONDING SPECIAL SYMBOL	
A	B	A	B
à (French keycaps)	} (Space)	T	μ
É (Swedish/Finnish keycaps)		U	π
§ (Spanish or German keycaps)		V	ρ
@ (Other keycap sets)		W	σ
A	/	X	ω
B	≡	Y	≤
C	~	Z	≥
D	↶	° (French keycaps)	} θ
E	≠	Å (Swedish/Finnish or German keycaps)	
F	↑	í (Spanish keycaps)	
G	➔	Æ (Danish/Norwegian keycaps)	
H	↓	[(Other keycap sets)	
I	➔	§ (French keycaps)	} (Space)
J	*	Ö (Swedish/Finnish or German keycaps)	
K	Σ	Ñ (Spanish keycaps)	
L	Δ	Ø (Danish/Norwegian keycaps)	
M	∪	/ (Other keycap sets)	
N	∩	§ (French keycaps)	} °
O	÷	ø (Swedish/Finnish or Danish/Norwegian keycaps)	
P	α	º (Spanish keycaps)	
Q	β	Ü (German keycaps)	
R	δ] (Other keycap sets)	
S	λ		

SYMBOLS

COLUMN A CONVENTIONAL ENTRY FOR ALL KEYCAP SETS UNLESS OTHERWISE NOTED		COLUMN B CORRESPONDING SPECIAL SYMBOL	
A	B	A	B
ü (Swedish/Finnish keycaps)	(Space)	o	(Space)
^ (Other keycap sets)		p	∖
_ (Underline)	»	q	∖
é (Swedish/Finnish keycaps)	} c̄	r	/
' (Grave accent on other keycap sets)		t	/
a	..	u	-
b	□	v	
c	o	w	
d	◆	x	∕∕
e	x	y	∕∕
f	'	z	=
g	/	e' (French keycaps)	} =
h	v	ä (Swedish/Finnish or German keycaps)	
i	↑	æ (Danish/Norwegian keycaps)	
j		ç (Spanish keycaps)	
k	<	{ (Other keycap sets)	
l	>		
m	} (Space)		
n			

SYMBOLS

COLUMN A CONVENTIONAL ENTRY FOR ALL KEYCAP SETS UNLESS OTHERWISE NOTED		COLUMN B CORRESPONDING SPECIAL SYMBOL	
A	B	A	B
ù (French keycaps)	} ▴	ˆ (French keycaps)	} ▴
ö (Swedish/Finnish or German keycaps)		ü (Swedish/Finnish keycaps)	
ñ (Spanish keycaps)		ˉ (Overbar on British or Danish/Norwegian keycaps)	
ø (Danish/Norwegian keycaps)		β (German keycaps)	
! (Other keycap sets)		~ (Other keycap sets)	
e (French keycaps)	} ▴	DEL (Delete)	} ▴
å (Swedish/Finnish or Danish/Norwegian keycaps)			
¿ (Spanish keycaps)			
ü (German keycaps)			
} (Other keycap sets)			

CYBER-Mode Test

This self test can only be run when the terminal is in CYBER mode. It may be started by your host computer or by entries on the keyboard.

Host CYBER-Mode Test

When the terminal receives a start-test command from your host computer, it reruns the terminal self test. The terminal sends a message to the host indicating whether the test found a problem. No message appears on your screen if a problem is found. The screen clears when the test is over.

Local CYBER-Mode Test

To run this test, the terminal must be in CYBER mode and offline (an operator parameter). Hold down the CTRL key, and press the = key and V key to rerun the terminal self test until the test finds a problem or you press RESET. If a problem is found, the test stops and the screen displays an error message. Turn to the Screen Messages in the Problem Solving Guide if an error message is displayed.

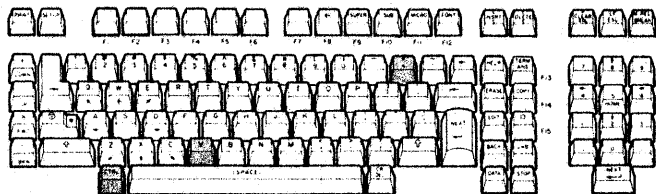

Cleaning the Keyboard and the Display Terminal

- 1 Turn off the terminal by pressing the side of the POWER switch marked with a 0.

CAUTION: Do not use solvents to clean the keyboard. Solvents can cause defective key operation and damage keycaps.

- 2 Dust the keyboard with a soft-bristled brush.
- 3 To clean keycaps, use a clean soft cloth dampened with glass cleaner containing ammonia.
- 4 Wipe the outside of the display-terminal cabinet using a soft, damp, lint-free cloth.
- 5 Use a soft, lint-free cloth dampened with glass cleaner on the display-terminal screen or touchpanel. Do not allow any glass cleaner to run down the screen or get into the keyboard.

Introduction

If you are having a problem with your terminal, look in this guide to fix or locate the problem. The guide gives you four ways to solve problems:

- **Screen Messages:** When there is a problem, messages often appear on the terminal screen. If a message appears, look up the message in the Screen Messages section of this guide.
- **Using the HELP Sections:** Use the Display Terminal HELP or the Keyboard HELP when you think there is an equipment problem. They give a step-by-step way of fixing or locating the problem. HELP 100 shows how to repack a unit to bring or send it to a Service Center.
- **Using the HOTLINE:** If you have used the HELP Tables and haven't solved the problem, you can get help by calling the HOTLINE. The HOTLINE is a telephone service to help owners of Control Data equipment. The HOTLINE number is:

1-800-ACS-9999
612-482-2739 (Minnesota)

- **Using a Control Data Service Center:** You may be guided by the HELP Tables or the HOTLINE to call or bring your equipment to a Service Center. At each Control Data Service Center are technicians trained to solve equipment problems. A pamphlet that came with the display terminal lists the address and telephone number of the Service Center nearest you.

Screen Messages

Terminal Needs Service Messages

If any of these messages appear on your screen, the display terminal needs service. Turn to HELP 100.

BLANK (on the operation test screen)
 CHARACTER RAM FAIL
 COMM FAIL
 EXT KBD LOOPBACK FAIL
 INTERNAL MODEM CHECKSUM FAIL
 INTERNAL MODEM LOOPBACK FAIL
 INTERNAL MODEM UART FAIL
 KBD CLOCK FAIL
 KEYBOARD FAIL
 RAM FAIL XXXX XX XX
 ROM FAIL XX XX XX
 TIMER FAIL

You-Can-Probably-Fix-It Messages

When any of these messages appear, find the message on the following pages. You will be told WHY the message appeared and WHAT TO DO about it. The messages appear in alphabetical order.

If the screen message still appears after you have done what is described in WHAT TO DO, go to the HELP pages.

BATTERY LOW
 DISK LOAD FAIL (with) FAILURE LOADING MODE
 FAILURE LOADING MODE (alone)
 GRAPHIC FAIL
 HOST LOAD FAIL (with) FAILURE LOADING MODE
 NVM ALTERED
 PARALLEL PORT FAIL
 PORT A FAIL
 PORT B FAIL (see PORT A FAIL)
 SERIAL PORT TEST SWITCH ENABLED
 TEST SWITCH ENABLED

You Can Disregard These Messages

These messages give information and do not indicate a problem.

GRAPHICS X.X
 INTERNAL MODEM REV X.X
 RES REV X.X
 COPYRIGHT CONTROL DATA 198X

BATTERY LOW

WHY?

The battery within the terminal is wearing out. This battery keeps the parameter settings active when the terminal is turned off.

WHAT TO DO

First, get a 9-volt alkaline battery from a local source. Then with the terminal *turned on*, find the battery cover on the back of the terminal. Remove the screw that holds the battery cover in place. Remove the battery cover and battery. Disconnect the battery from the connector and connect the new battery. Replace the battery, battery cover, and screw.

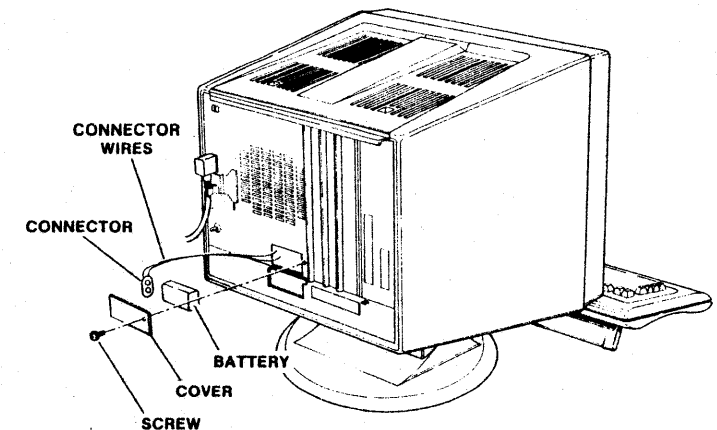

DISK LOAD FAIL (with) FAILURE LOADING MODE

WHY?

- 1** Flexible disk is inserted wrong side up.
- 2** No disk is in the drive.
- 3** The disk is bad.
- 4** The flexible disk was changed, and the program on the new disk was called (by pressing a key on the keyboard) without resetting the primary flexible-disk drive.
- 5** You tried to load a disk with the wrong F key.
- 6** The terminal or flexible-disk drive has a problem.

WHAT TO DO

- 1** Remove the disk and insert it right side up. Reset the flexible-disk drive and load the disk using the proper F key.
- 2** Insert the disk. Then reset the flexible-disk drive and load the disk using the proper F key.
- 3** Remove the disk and try another disk.
- 4** Reset the flexible-disk drive and call the program with the proper F key.
- 5** Reset the flexible disk drive and call the program with the proper F key.
- 6** If there is still a problem, the terminal or flexible-disk drive may need service. Go to HELP 100.

FAILURE LOADING MODE (alone)

WHY?

- 1** You tried to load from a flexible disk and you pressed the wrong F key, or parameters are not set correctly for a flexible-disk drive.
- 2** You tried to load from a host computer using an internal or external modem and you pressed the wrong F key, or parameters are not set correctly for your type of modem.
- 3** You tried to load from a memory module and you pressed the wrong F key, or parameters are not set correctly for a memory module, or the memory module needs replacement.

WHAT TO DO

- 1** Reset the terminal and load the disk with the right F key. If the message appears again, check that F2, position 5 of the terminal installation parameters is a 1, and F3, position 4 is a 1. For the mode you are using, check that mode installation parameter F2, position 1 is a 1. See the Changing Parameters section in the Operating Guide.
- 2** Reset the terminal and press the right F key. If the message appears again, check that terminal installation parameter F3, position 1 is correct. For the mode you are using, check that mode installation parameter F2, position 1 is a 1 and that F2, position 6 is correct. See the Changing Parameters section in the Operating Guide. Turn to the heading Additional Parameters in the Installation section. Check that parameters associated with an internal or external modem are set correctly.
- 3** Reset the terminal and load the memory module with the right F key. If the message appears again, see your memory module manual to check that parameters are set correctly. If the message still appears, the memory module may need replacement. Go to HELP 100.

GRAPHIC FAIL**WHY?**

- 1 Terminal installation parameter F3, position 3 is set wrong.
- 2 The terminal or graphics board needs service.

WHAT TO DO

- 1 Check terminal installation parameter F3, position 3. See the Changing Parameters section in the Operating Guide. If you have a graphics board installed, this position should be a 1. If you do not have a graphics board, this position should be a 0.
- 2 Press RESET. If the message appears again, the terminal needs service. Go to HELP 100.

**HOST LOAD FAIL (with) FAILURE
LOADING MODE****WHY?**

- 1 You pressed the wrong F key.
- 2 You're trying to load from a computer or network, and you're using the wrong telephone number or an invalid file number.
- 3 The telephone number you're using to call the computer or network is busy.
- 4 You're trying to load from a computer or network that isn't currently operating.
- 5 If this is the first time you have tried loading from the computer or network, the mode installation parameters are not set right.
- 6 There is a problem with your modem, terminal, or telephone service.

WHAT TO DO

- 1 Reset the terminal and press the right F key.
- 2 Look at your network subscription literature or the Sign-On Information in the Operating Guide to make sure you're using the right telephone number and file number.
- 3 Use an alternate telephone number and try again.
- 4 Call the number on a telephone to make sure that the telephone service is operating and that the computer network is operating. You should hear several rings and then an answer tone (a buzzing sound) if the network is operating. If you don't get an answer, the network isn't operating.
- 5 If this is the first time you have tried to load from the computer or network, see your network subscription literature and make sure mode installation parameters are set right for network operations.
- 6 If your terminal has an internal modem, do this step before going to step 7. Reset the terminal, and when the Mode Selection display appears, hold the CTRL key down while pressing the SETUP key. This displays the terminal installation parameters. Check that the F4 block, position 3 is a 1. If necessary, make a change and then press the COPY key.
- 7 Reset the terminal to run its self test (the test will take longer than usual if the parameter was changed in step 6). If a FAIL message appears, go to the part of this section which covers that message.
- 8 Notify network personnel of your problem. Don't forget to change the parameter back if it was changed in step 6.

NVM ALTERED**WHY?**

- 1** The parameter settings in memory have been altered because the battery is dead or because the battery was removed with the terminal turned off.
- 2** The NVM has been written into improperly.
- 3** The terminal has reloaded the default parameters.
- 4** The NVM (non-volatile memory) is not working.

WHAT TO DO

- 1** If the battery is dead, replace the battery using the instructions under the BATTERY LOW message. Then reset the parameters as shown on the Terminal and Mode Installation Parameter Records in the Installation Guide. (Be sure to press COPY.)

If the battery was removed with the terminal turned off (and the battery is still good) put the battery back in the terminal by following the instructions under the BATTERY LOW messages. Then reset the parameters as shown on the Terminal and Mode Installation Parameter Records in the Installation Guide. (Be sure to press COPY.)

- 2** Reset the parameters as shown on the Terminal and Mode Installation Parameter Records in the Installation Guide. (Be sure to press COPY.)
- 3** Reset the parameters as shown on the Terminal and Mode Installation Parameter Records in the Installation Guide. (Be sure to press COPY.)
- 4** Press RESET. If NVM ALTERED appears again, the terminal needs service. Go to HELP 100.

PARALLEL PORT FAIL**WHY?**

- 1** A parallel graphics printer and/or flexible-disk drives weren't ready when the TEST switch was pulled out during testing.
- 2** Terminal installation parameters are not set right.
- 3** There is a problem on the parallel port.

WHAT TO DO

- 1** Be sure the device connected to the parallel-interface board (I/F-1) is turned on. If the device needs to be turned on, wait about 20 seconds after turning it on. If the device is a parallel graphics printer, be sure its PRINT switch is lit. (If it is not lit, press the PRINT switch to light it.) If the device is a flexible-disk drive, be sure a disk is in the drive. Push the TEST switch in. Press RESET. Press the F8 key twice. Pull out the TEST switch. If PARALLEL PORT OK appears, the problem is fixed. If not go to step 2.
- 2** Reset the terminal. Check that terminal installation parameter F3, position 4 is a 1. See the Changing Parameters section of the Operating Guide.

If you have a parallel graphics printer, check that F2, position 4 is a 1. Make any necessary changes and press the COPY key. Then press the F1 key. With the Mode Selection display on the screen, press the F8 key twice. Pull out the TEST switch. If PARALLEL PORT FAIL still appears, go to step 3.

- 3** There is a problem on the parallel port. Go to HELP 100.

PORT A FAIL PORT B FAIL

WHY?

- 1 If both messages appear after you turn on or reset the terminal, you pressed a key on the keyboard before the terminal had completed its self test.
- 2 If both messages appeared when the TEST switch on the terminal was pulled out, you didn't push the TEST/NORMAL switch on the serial-interface board to TEST before pulling out the TEST switch.
- 3 A serial-interface board is not installed correctly; the installation parameter for the serial-interface board is set to a 1, and the board is not installed; or the serial-interface board is bad.

WHAT TO DO

- 1 When turning on or resetting the terminal, wait until the terminal beeps and the Mode Selection display appears on the screen before pressing any keys.
- 2 If the TEST switch on the terminal is pulled out, push the TEST/ NORMAL switch on the serial-interface board to TEST. Now push the TEST switch in and pull it back out.
- 3 Check that the serial-interface board (I/F-2) is installed right and that the screws are tightened to hold the board in place.

Reset the terminal. Hold the CTRL key down and press the SETUP key. If you do not have a serial-interface board, F2, position 3 should be a 0. If the parameter is wrong, change it. Then press the COPY key and the F1 key. Retry what you were doing. If one or both messages appear again, the serial-interface board needs service. Go to HELP 100.

SERIAL PORT TEST SWITCH ENABLED

WHY?

- 1 The TEST/NORMAL switch on the serial-interface board is in the TEST position.

WHAT TO DO

- 1 Push the TEST/NORMAL switch to the NORMAL position and also be sure the TEST switch on the back of the terminal is pushed in. Then reset the terminal.

TEST SWITCH ENABLED

WHY?

- 1 The TEST switch on the back of the terminal is pulled out into the TEST position.

WHAT TO DO

- 1 Push the TEST switch in and reset the terminal.

Display Terminal Help

These pages contain information to help you if you have problems when using your terminal.

The last HELP in this guide is HELP 100. HELP 100 tells how to contact the HOTLINE, or a Service Center, and what to do to send or bring your equipment in for service.

Find the type of problem you are having in the boxes on this page, then go to the appropriate HELP.

Nothing appears on the display terminal screen.

→ Go to Display Terminal **HELP 1.**

Display on screen rolls, is bent, distorted; or brightness; cannot be turned up or down; or circuit breaker keeps popping out.

→ Go to Display Terminal **HELP 2.**

Unexpected message or a FAIL message appears on the screen.

→ Go to Screen Messages.

Meaningless symbols appear on the screen; or alarm does not work right; or Mode Selection display blocks are missing; or self test keeps repeating.

→ Go to Display Terminal **HELP 3.**

Only a cursor appears in the upper-left corner of the screen, and nothing else seems to work.

→ Go to Display Terminal **HELP 4.**

Not as many lines on the screen as you expect to see or to use.

Not as many characters appear on a line as you expect to see.

The dim, blink, underscore, or inverse feature is not working.

Front-panel light or lights come on when they shouldn't.

On the screen, characters are missing, or wrong characters appear.

Nothing happens when you touch the touchpanel, or the response is wrong.

When the terminal is reset, the self test does not happen (patterns do not flash on the screen).

→ Go to Display Terminal **HELP 5.**

Data in left margin seems too close or too far from side of screen, or data in first line seems too close or too far from top of screen.

→ Go to Display Terminal **HELP 5.**

Information on the screen is double-spaced when it shouldn't be, or two characters appear when you press a key.

→ Go to Display Terminal **HELP 6.**

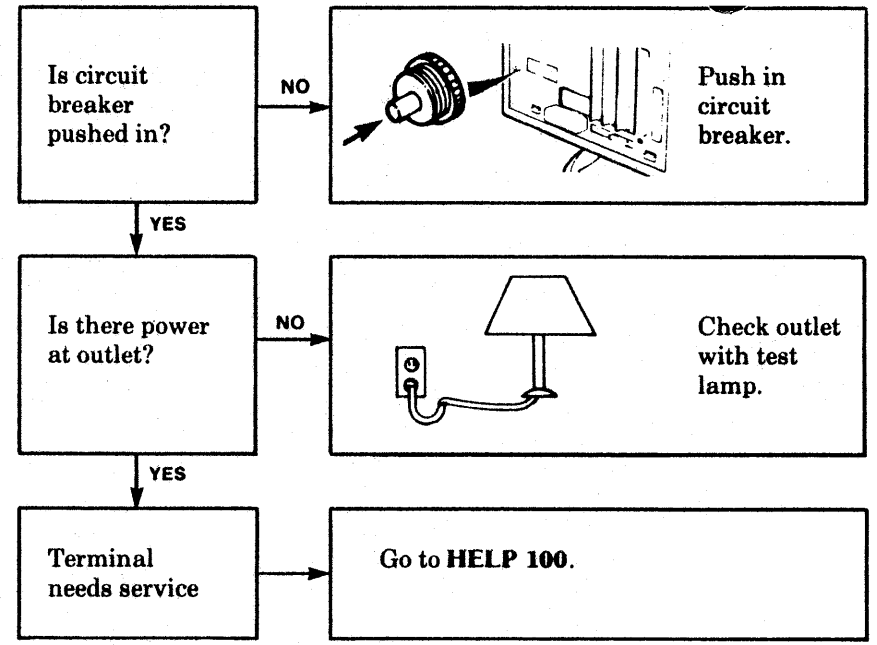
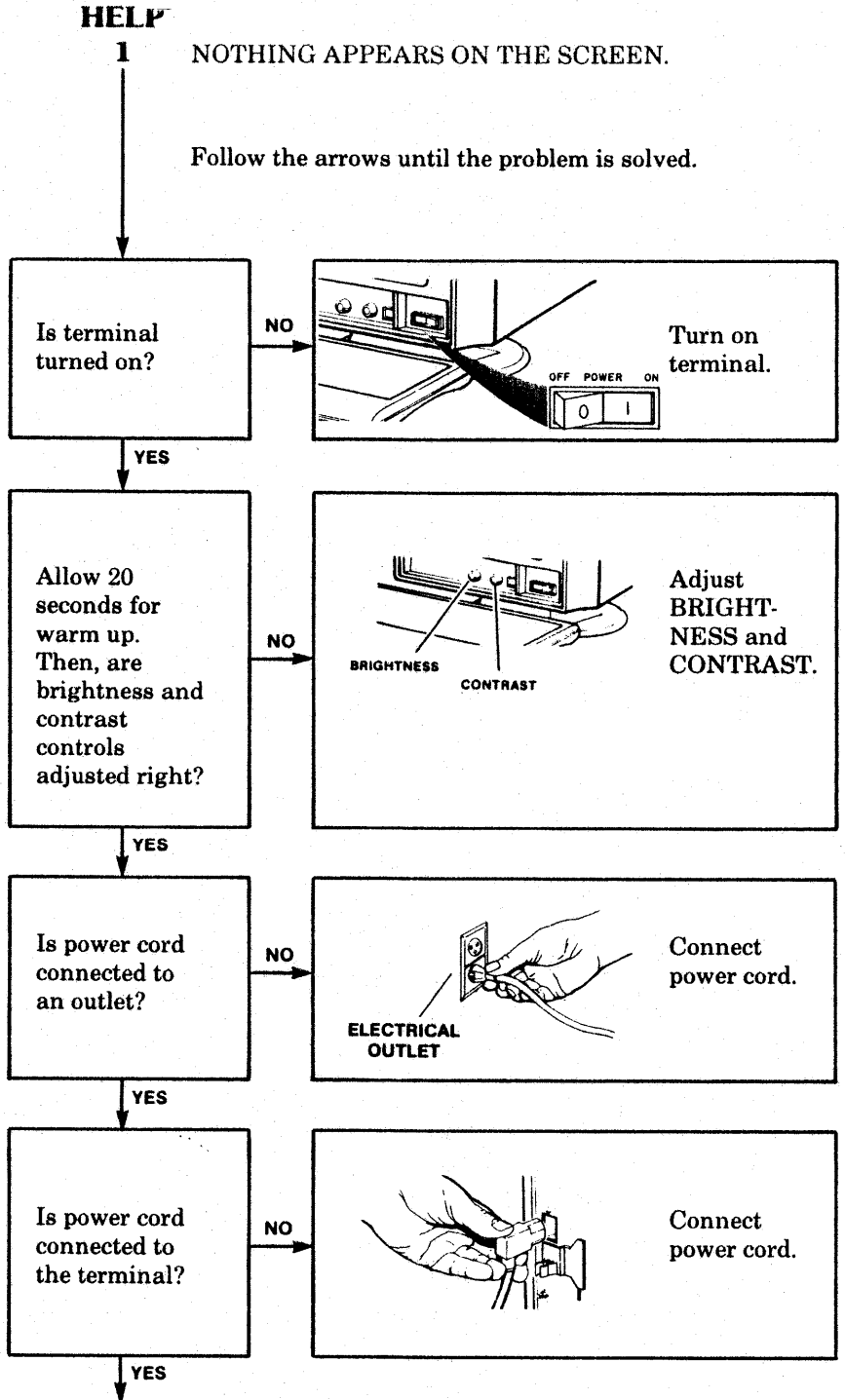

HELP 2 DISPLAY ON SCREEN ROLLS, IS BENT, DISTORTED, OR BRIGHTNESS CANNOT BE TURNED UP OR DOWN; OR CIRCUIT BREAKER KEEPS POPPING OUT

Follow the arrows until the problem is solved.

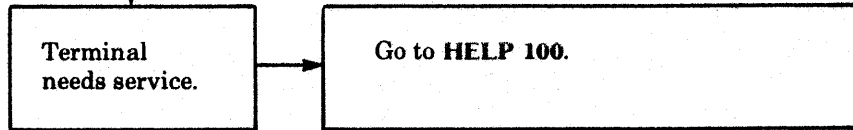

HELP 3 MEANINGLESS SYMBOLS APPEAR ON THE SCREEN, OR ALARM DOES NOT WORK RIGHT, OR MODE SELECTION BLOCKS ARE MISSING, OR SELF TEST KEEPS REPEATING

Follow the arrows until the problem is solved.

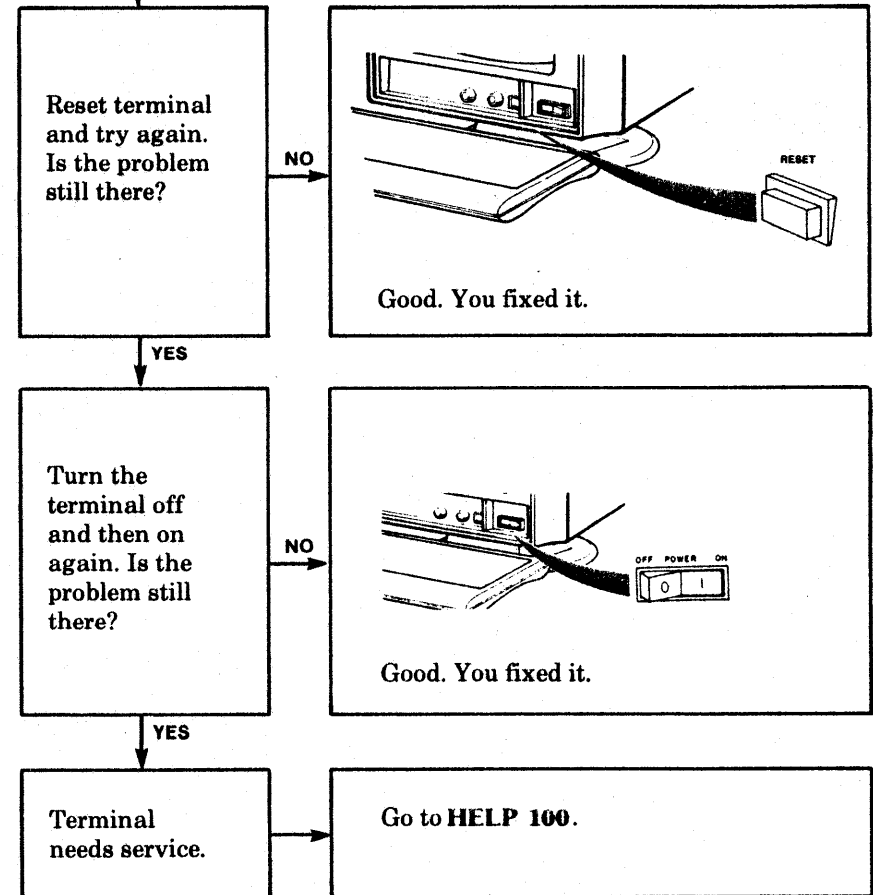

HELP 4 ONLY A CURSOR (A HYPHEN OR A BLOCK) APPEARS IN THE UPPER-LEFT CORNER OF THE SCREEN, AND NOTHING ELSE SEEMS TO WORK
Follow the arrows until the problem is solved.

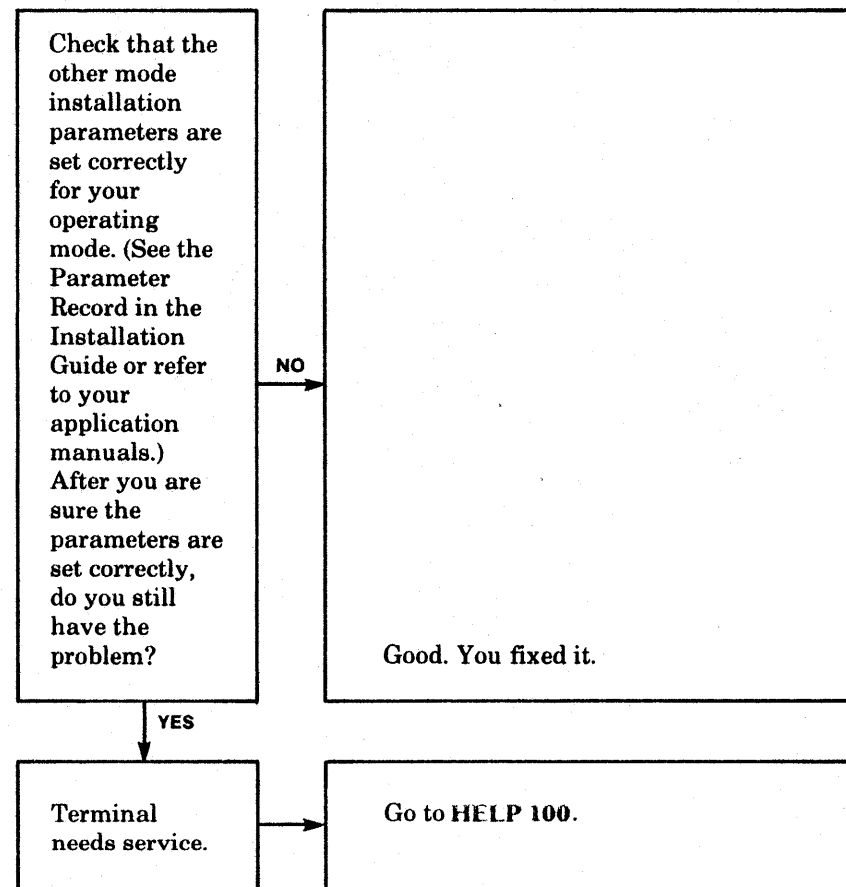
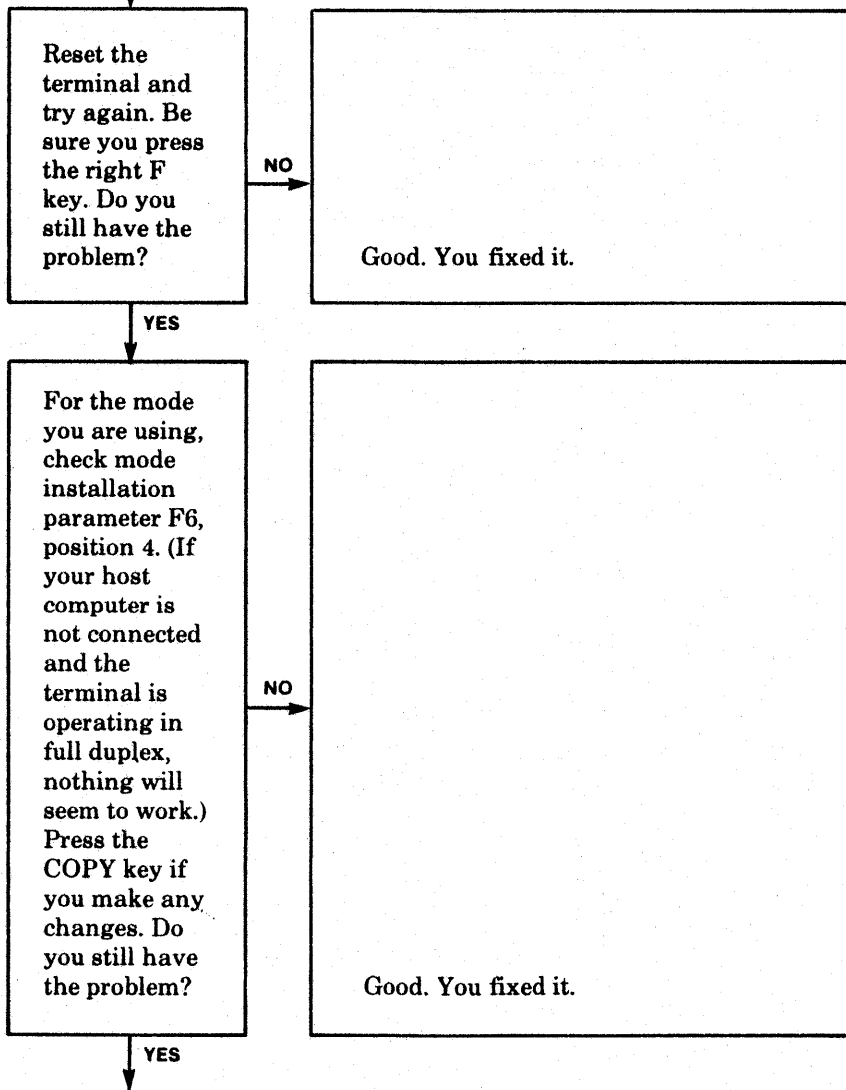

HELP

5

NOT AS MANY LINES ON THE SCREEN AS YOU EXPECT TO SEE OR TO USE

NOT AS MANY CHARACTERS APPEAR ON A LINE AS YOU EXPECT TO SEE

THE DIM, BLINK, UNDERSCORE, OR INVERSE FEATURE IS NOT WORKING

FRONT PANEL LIGHT OR LIGHTS COME ON WHEN THEY SHOULDN'T

ON THE SCREEN, CHARACTERS ARE MISSING, OR THE WRONG CHARACTERS APPEAR

NOTHING HAPPENS WHEN YOU TOUCH THE TOUCHPANEL, OR THE RESPONSE IS WRONG

WHEN THE TERMINAL IS RESET, THE SELF TEST DOES NOT HAPPEN (PATTERNS DO NOT FLASH ON THE SCREEN)

DATA IN LEFT MARGIN SEEMS TOO CLOSE OR TOO FAR FROM SIDE OF SCREEN, OR DATA IN FIRST LINE SEEMS TOO CLOSE OR TOO FAR FROM TOP OF SCREEN

Follow the arrows until the problem is solved.

Reset the terminal.

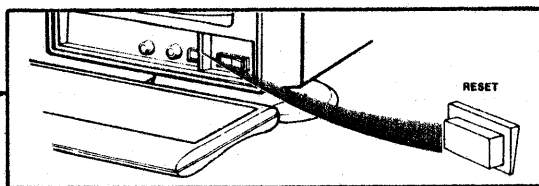

When the Mode Selection display appears, press the F8 key once.

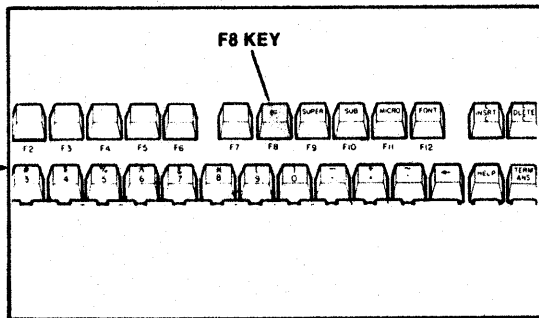

If you do not have a graphics board, skip this step. If you do have a graphics board, does the screen keep changing back and forth between two test patterns?

NO

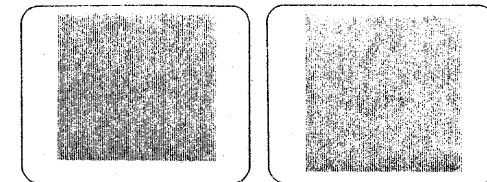

Terminal needs service. Go to **HELP 100**.

YES

Press the F8 key again.



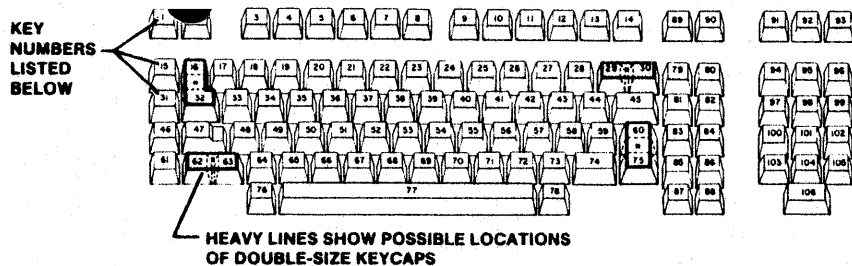

HEAVY LINES SHOW POSSIBLE LOCATIONS OF DOUBLE-SIZE KEYCAPS

KEY-CODE TABLE

KEY NUMBER	DISPLAYED CODE†		KEY NUMBER	DISPLAYED CODE†		KEY NUMBER	DISPLAYED CODE†	
	DOWN	UP		DOWN	UP		DOWN	UP
1	10	90	41	63	E3	76	25	A5
2	18	98	42	6B	EB	77	2D	AD
3	20	A0	43	73	F3	78	35	B5
4	28	A8	44	7B	FB	79	6E	EE
5	30	B0	45	7F	FF	80	36	B6
6	38	B8	46	12	92	81	77	F7
7	40	C0	47	1A	9A	82	6F	EF
8	48	C8	48	22	A2	83	5F	DF
9	50	D0	49	2A	AA	84	55	D5
10	58	D8	50	32	B2	85	5D	DD
11	60	E0	51	3A	BA	86	56	D6
12	68	E8	52	42	C2	87	45	C5
13	70	F0	53	4A	CA	88	4D	CD
14	78	F8	54	52	D2	89	7D	FD
15	11	91	55	5A	DA	90	75	F5
16*	19	99	56	62	E2	91	6D	ED
17	21	A1	57	6A	EA	92	37	B7
18	29	A9	58	72	F2	93	1D	9D
19	31	B1	59	7A	FA	94	16	96
20	39	B9	60*	67	E7	95	1E	9E
21	41	C1	61	14	94	96	26	A6
22	49	C9	62*	1C	9C	97	17	97
23	51	D1	63*	24	A4	98	1F	9F
24	59	D9	64	2C	AC	99	27	A7
25	61	E1	65	34	B4	100	4F	CF
26	69	E9	66	3C	BC	101	47	C7
27	71	F1	67	44	C4	102	3F	BF
28	79	F9	68	4C	CC	103	4E	CE
29*	7E	FE	69	54	D4	104	46	C6
30*	76	F6	70	5C	DC	105	3E	BE
31	13	93	71	64	E4	106	3D	BD
32*	1B	9B	72	6C	EC			
33	23	A3	73	74	F4			
34	2B	AB	74	7C	FC			
35	33	B3	75*	66	E6			
36	3B	BB						
37	43	C3						
38	4B	CB						
39	53	D3						
40	5B	DB						

* These keys may be covered with double-size keycaps. Pressing a double-size keycap displays the code for only one of the keys.

† Keycodes displayed during test are used internally and are not the same codes transmitted when online.

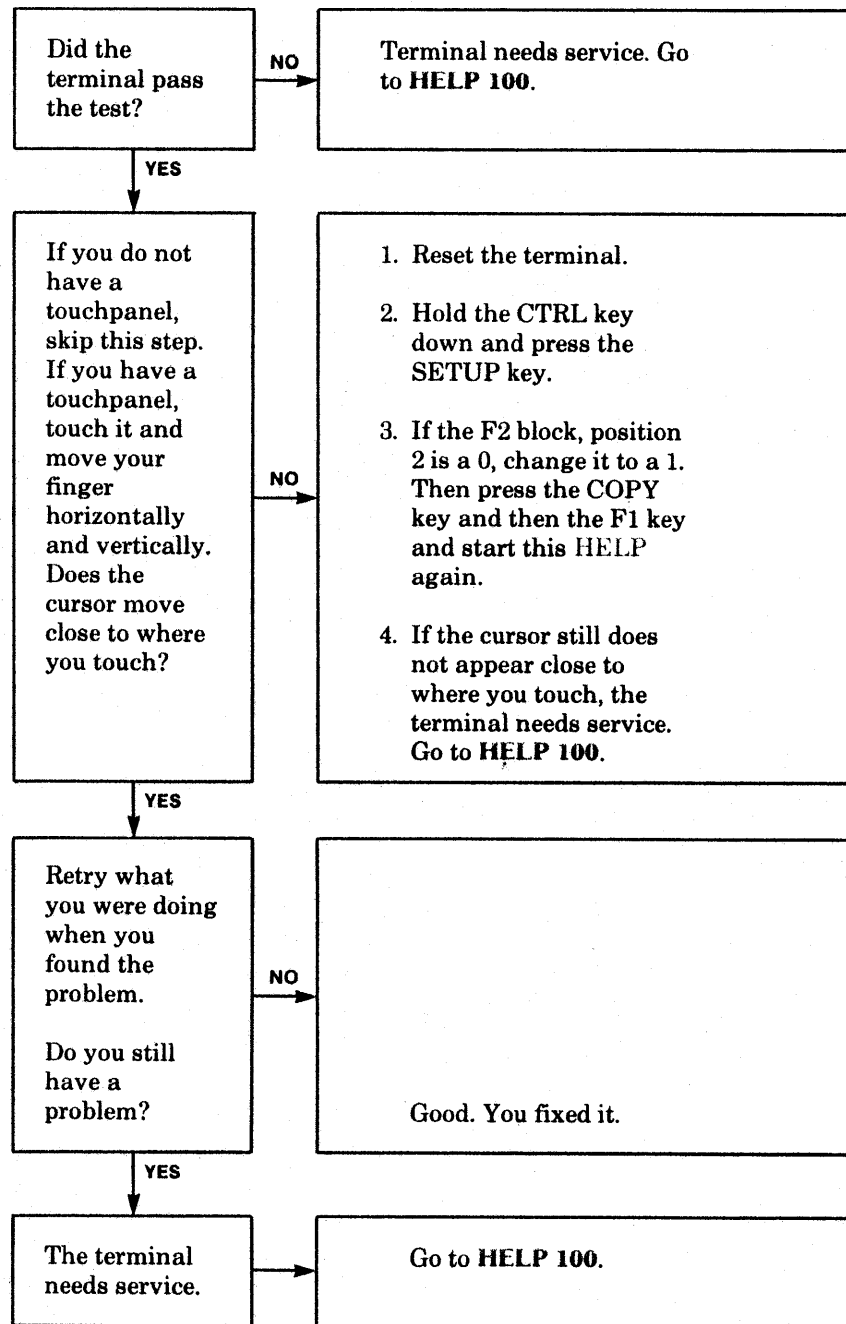

HELP

INFORMATION ON THE SCREEN IS DOUBLE-SPACED WHEN IT SHOULDN'T BE, OR TWO CHARACTERS APPEAR WHEN YOU PRESS A KEY

Follow the arrows until the problem is solved.

6

Reset the terminal and try loading again. Be sure you use the right F key.

Is the problem fixed?

YES

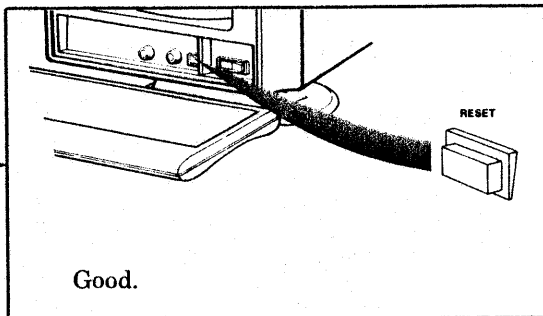

NO

For the mode you are using, check that mode installation parameter F6, position 4 is set correctly. (Operating the terminal in half duplex on a full-duplex system will cause double characters.) Also check mode installation parameter F4, position 6. Press the COPY key if you make any changes. Try loading again. Is the problem fixed?

YES

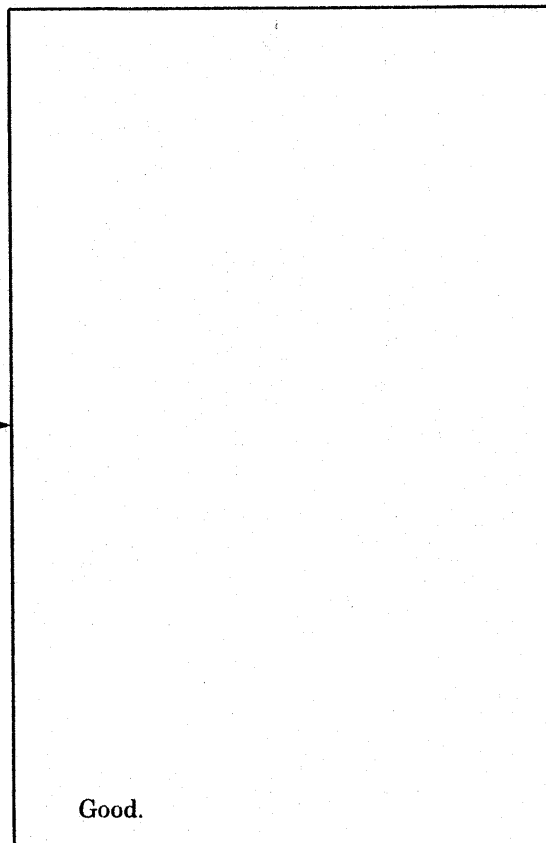

NO

Terminal needs service.

Go to **HELP 100**.

Keyboard Help

These pages contain information to help you if you have problems when using the display-terminal keyboard. Find the type of problem you are having in the boxes on this page, and then go to the called-for HELP section.

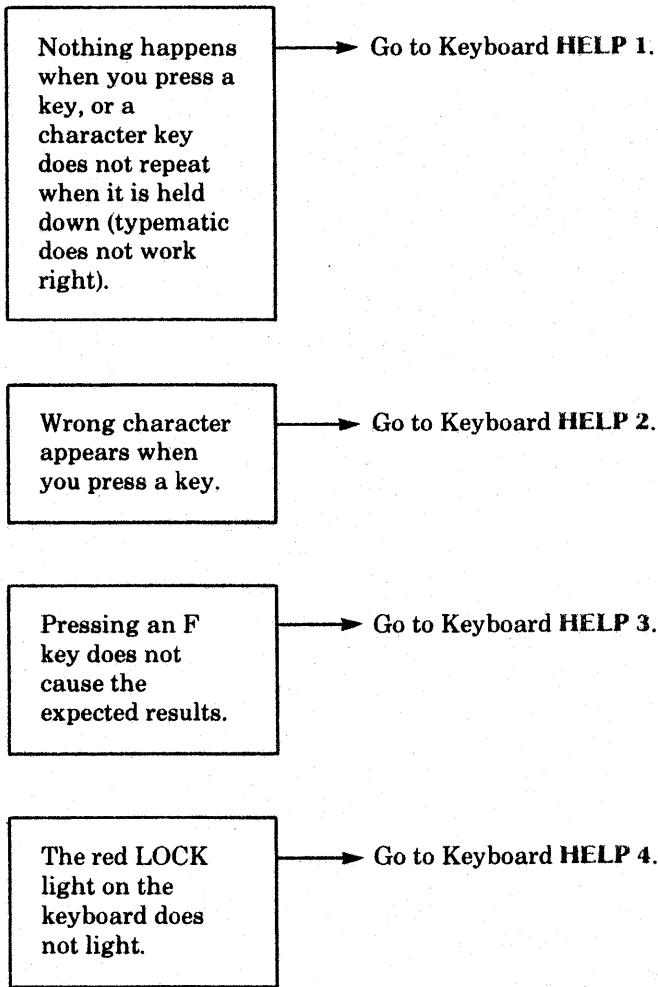

HELP 1

NOTHING HAPPENS WHEN YOU PRESS A KEY OR A CHARACTER KEY DOES NOT REPEAT WHEN IT IS HELD DOWN (TYPEMATIC DOES NOT WORK RIGHT)

When the keyboard is "locked out," nothing is supposed to happen when you press a keyboard key. Sometimes only certain keys are allowed to work, and the other keys are locked out. When you press a locked-out key, the terminal "beeps." Some keys or the entire keyboard may be locked out during some test programs, by the program that is operating at the time, or by another computer when it is controlling the operation of your terminal (the red LOCK light on the terminal front panel is on).

So, before going through this HELP, reset the terminal and try some familiar operation and see if the keyboard works. If the keyboard does not work, or you suspect only certain keys, continue with this HELP.

Follow the arrows until the problem is solved.

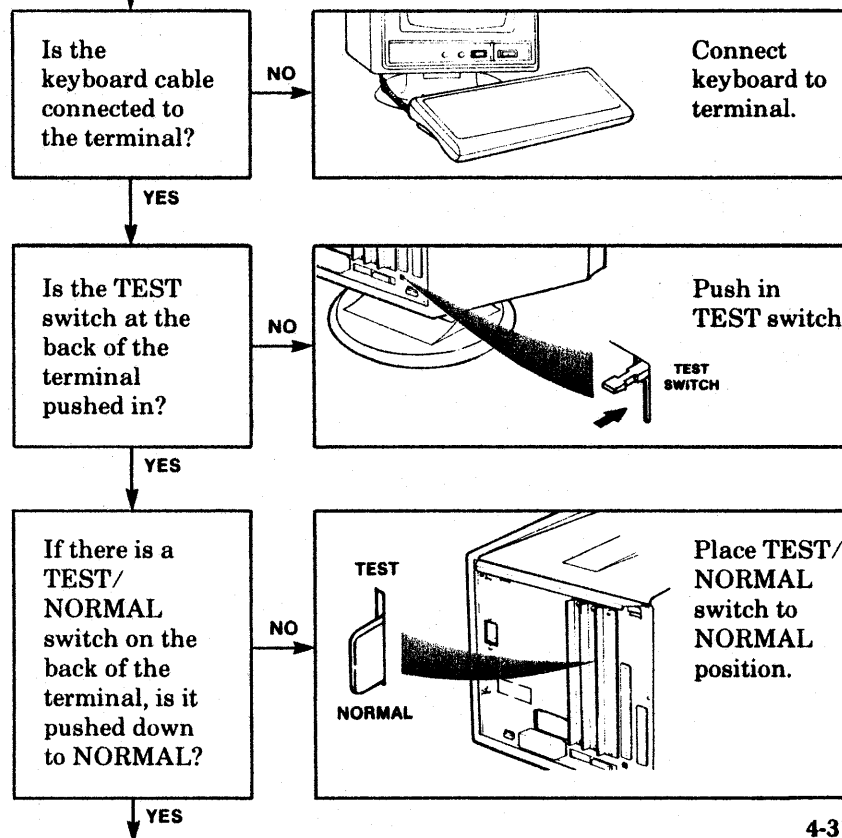

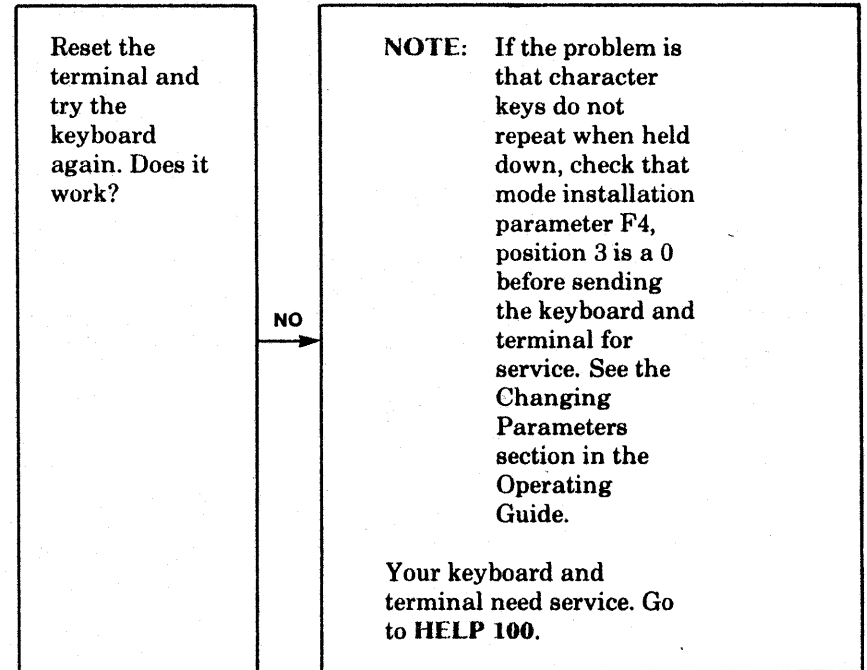
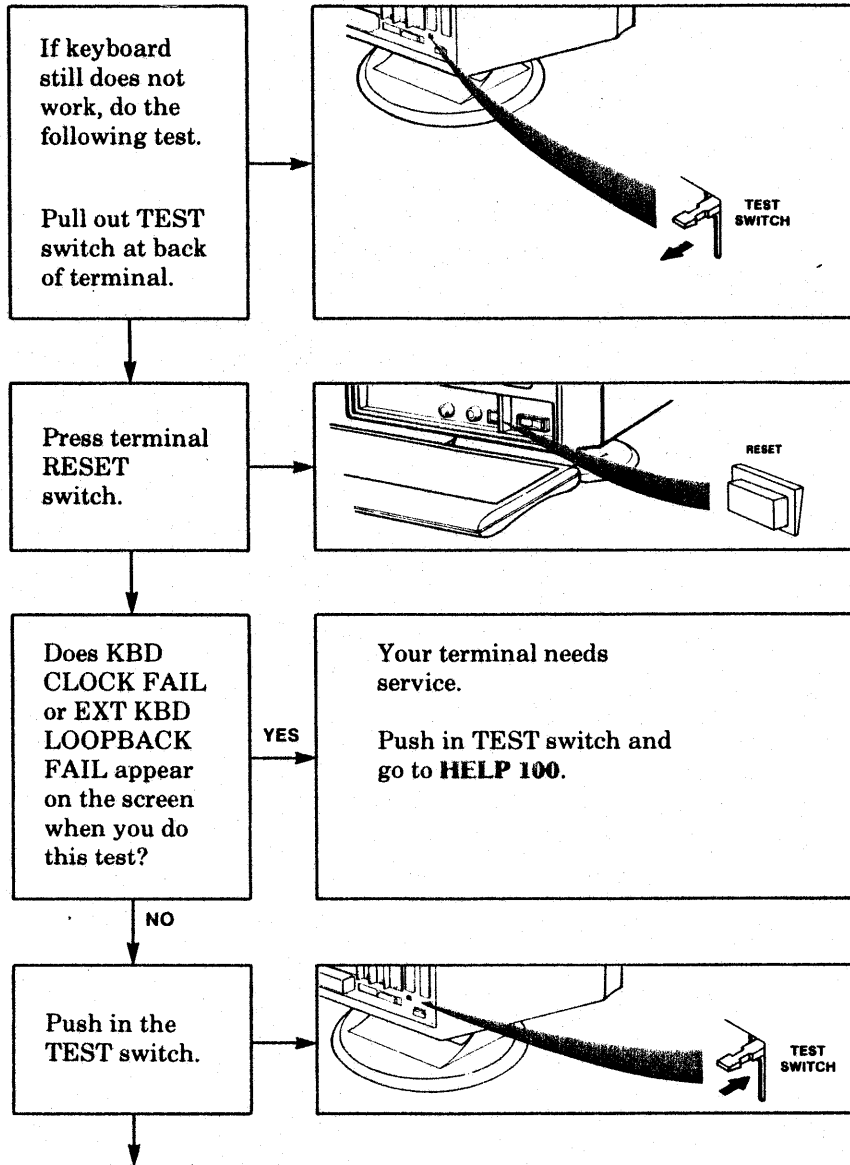

HELP 2 WRONG CHARACTER APPEARS WHEN YOU PRESS A KEY.

Follow the arrows until the problem is solved.

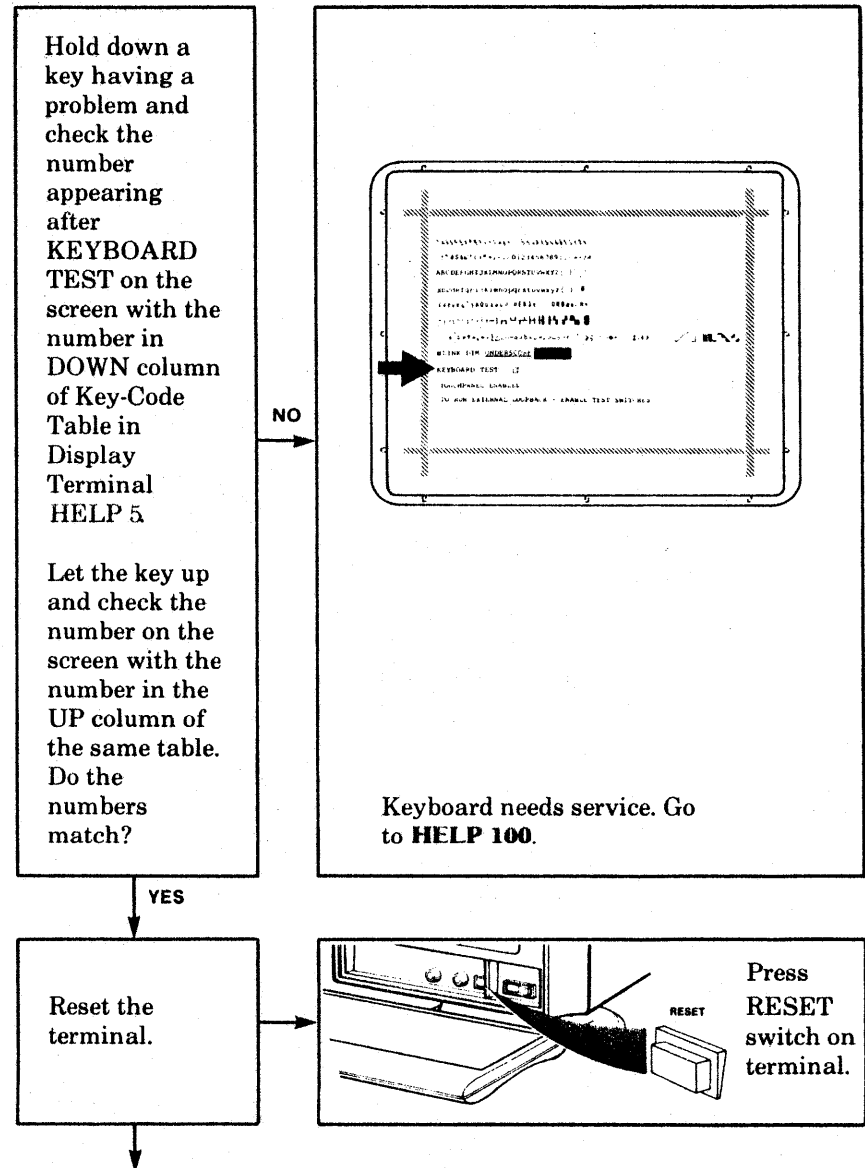
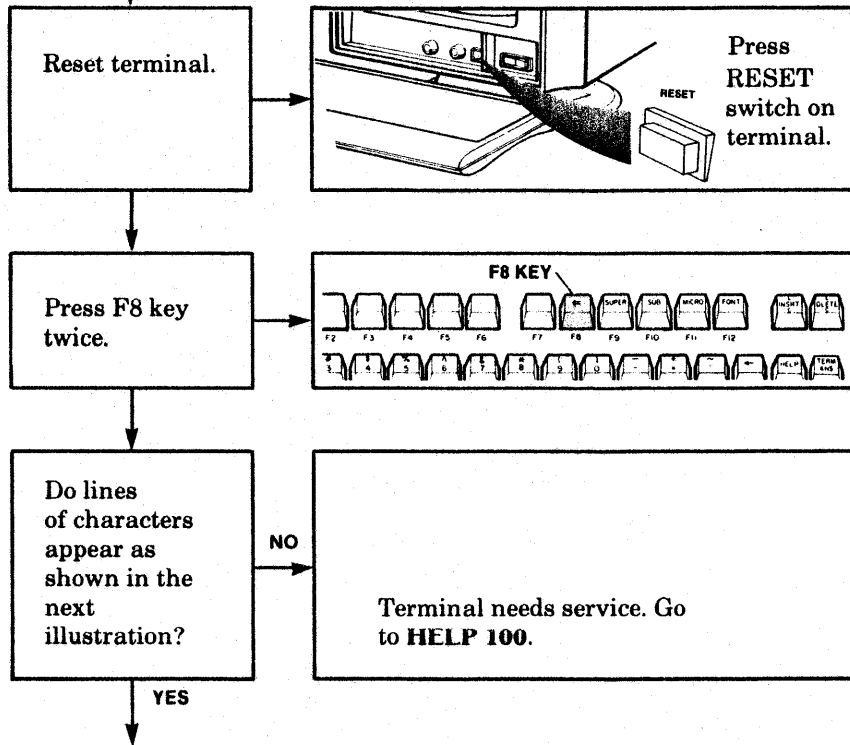

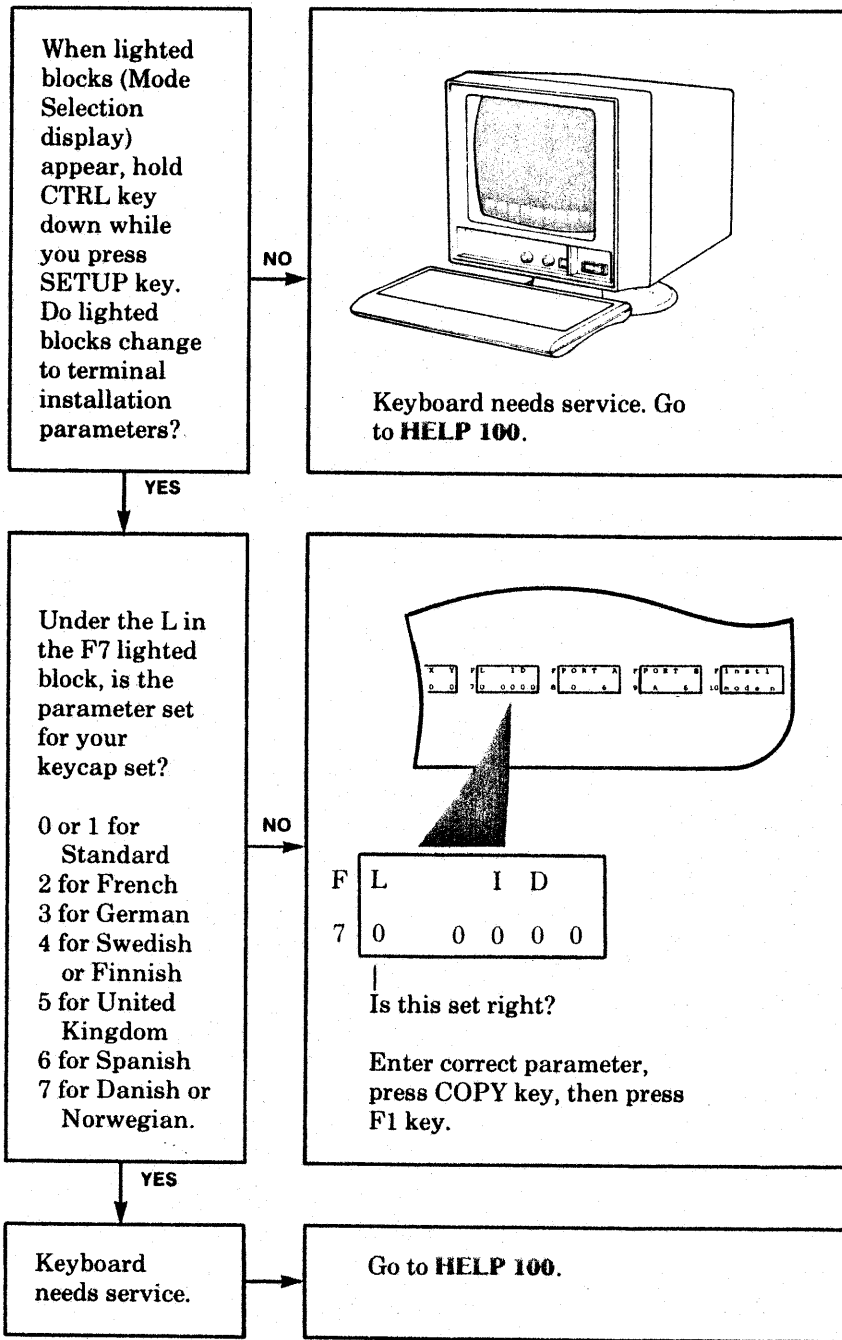

HELP 3 PRESSING AN F KEY DOES NOT CAUSE THE EXPECTED RESULTS
 Follow the arrows until the problem is solved.

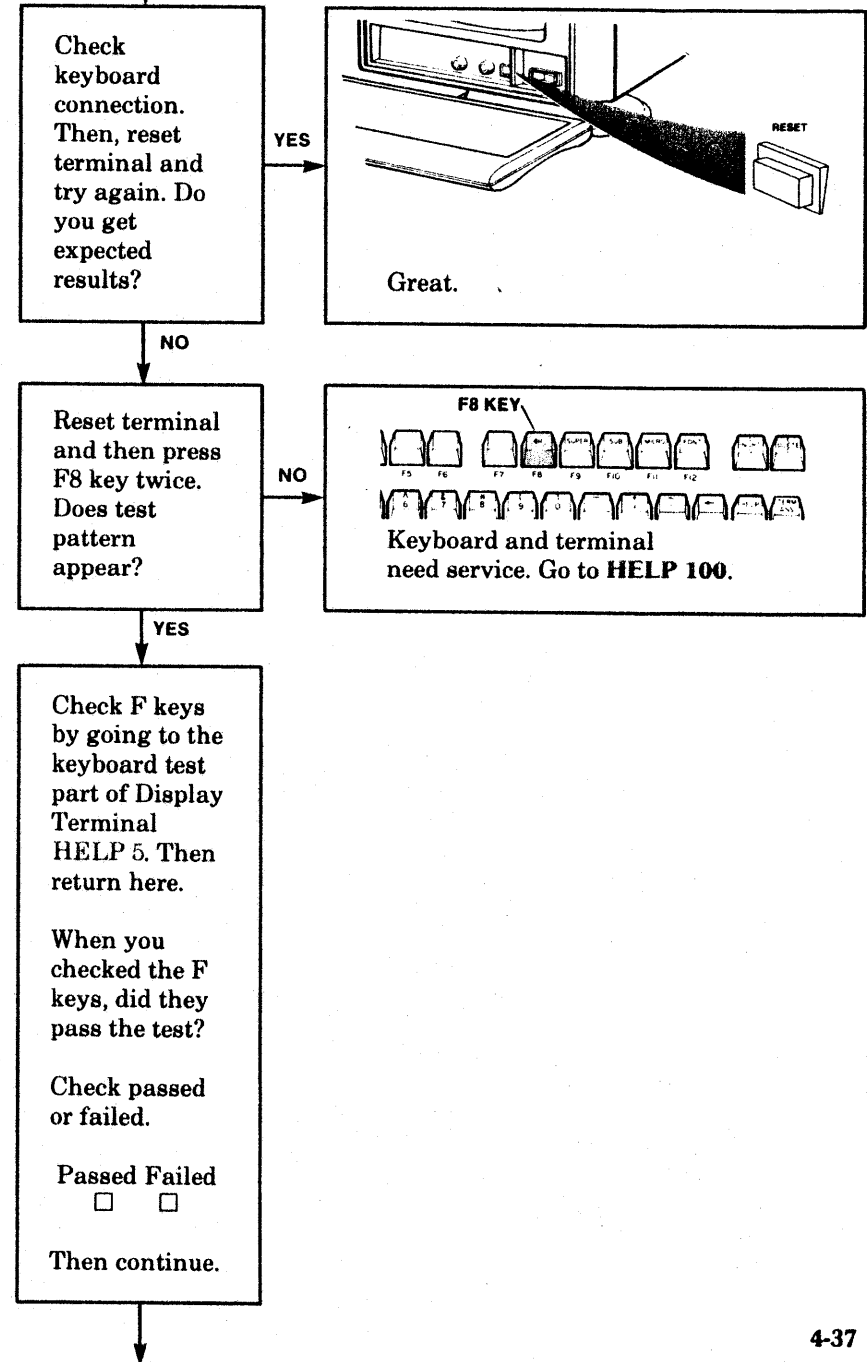

Do the following with the test pattern on the screen:

- If you have a serial-interface board, push TEST/NORMAL switch on back of terminal to TEST.

- Pull out the TEST switch at the back of the terminal.

Does KBD CLOCK FAIL or EXT KBD LOOPBACK FAIL message appear?

YES

Terminal needs service. Go to **HELP 100**.

NO

When you were asked to check passed or failed did you check FAILED?

YES

Keyboard needs service. Go to **HELP 100**.

NO

TEST
NORMAL

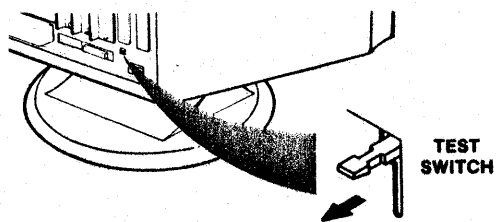
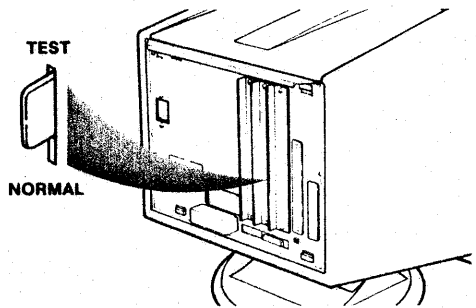

The keyboard and terminal seem to be OK. You may have a problem with how the parameters are set.

Return TEST/NORMAL switch to NORMAL and push in the TEST switch.

Check the parameter settings as follows:

Reset the terminal. When the lighted blocks appear on the screen, press and hold the CTRL key while you press the SETUP key.

Check all terminal installation parameters for proper settings.

TEST
NORMAL

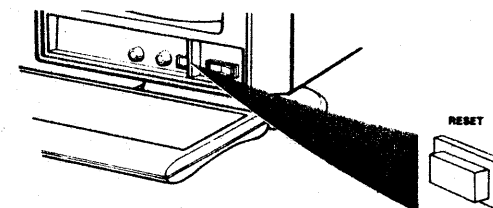
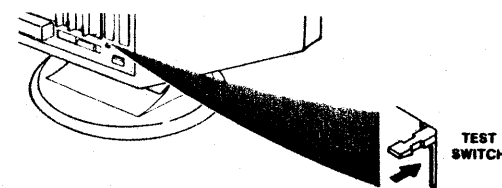
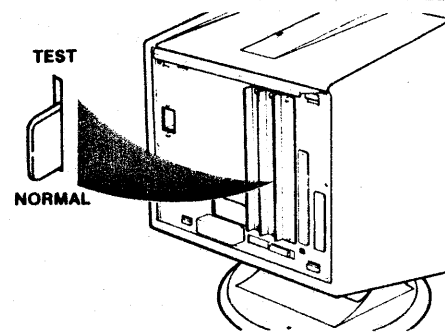

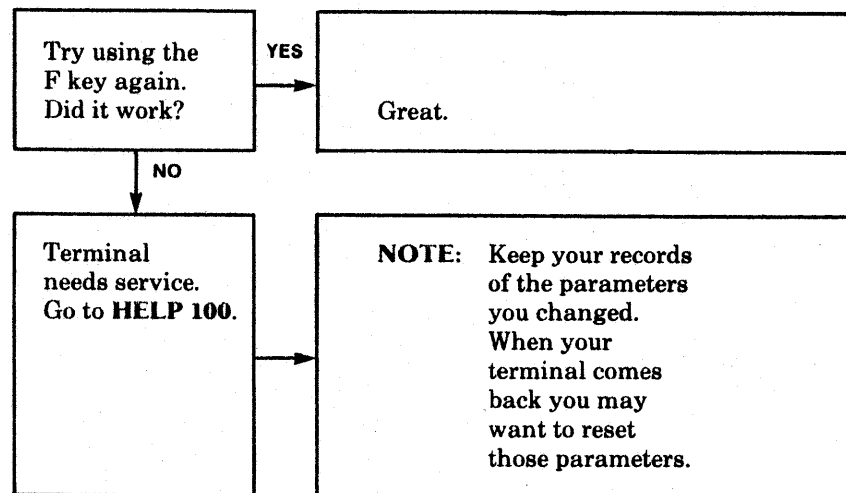
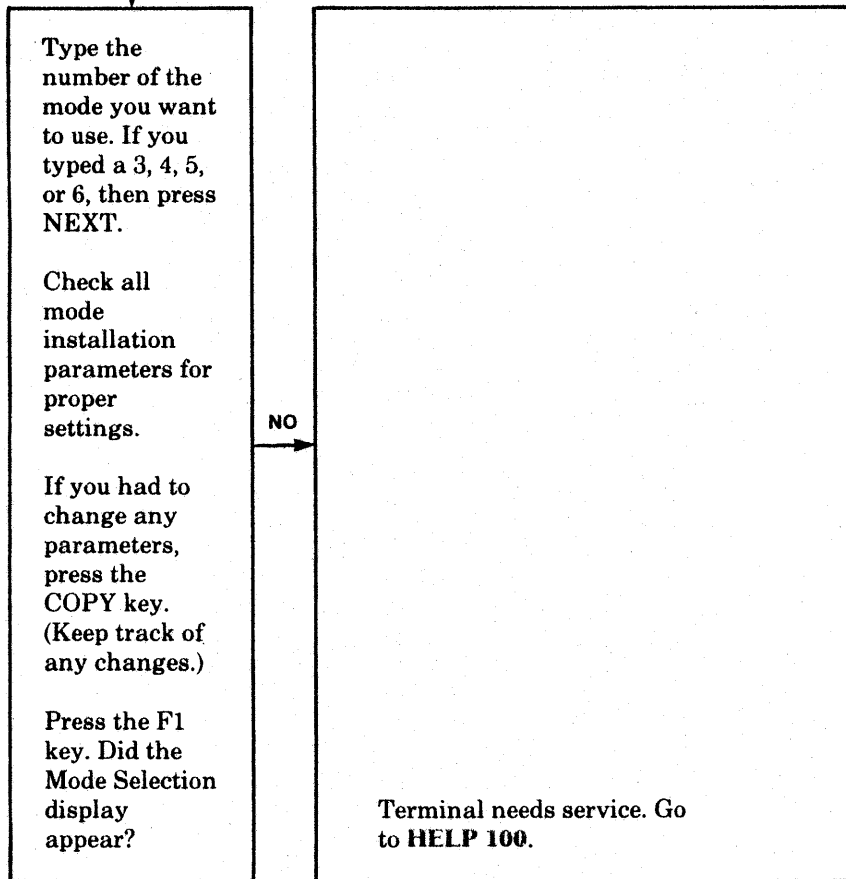
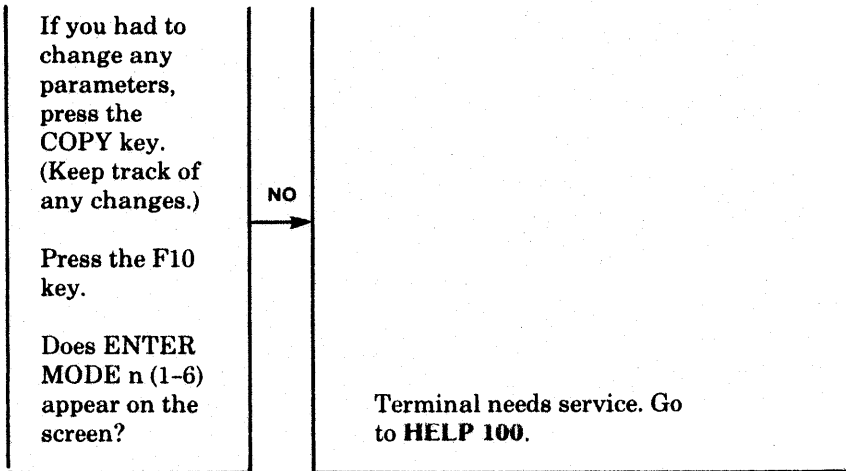

HELP 4 THE RED LOCK LIGHT ON THE KEYBOARD WILL NOT LIGHT

Follow the arrows until the problem is solved.

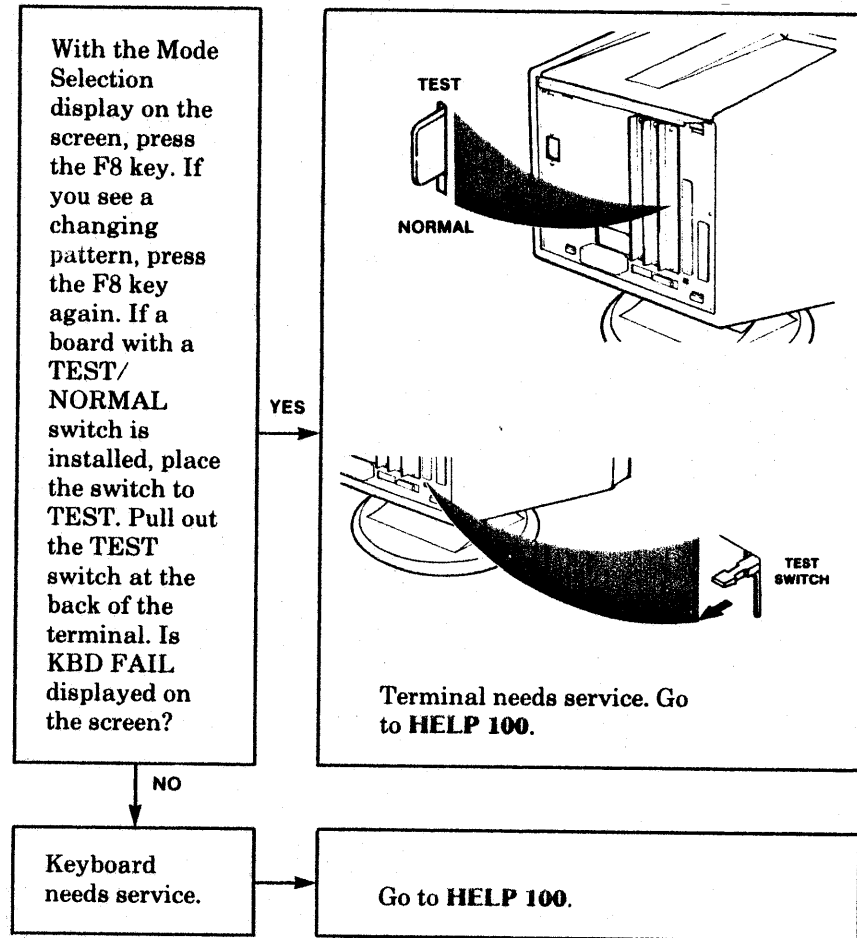
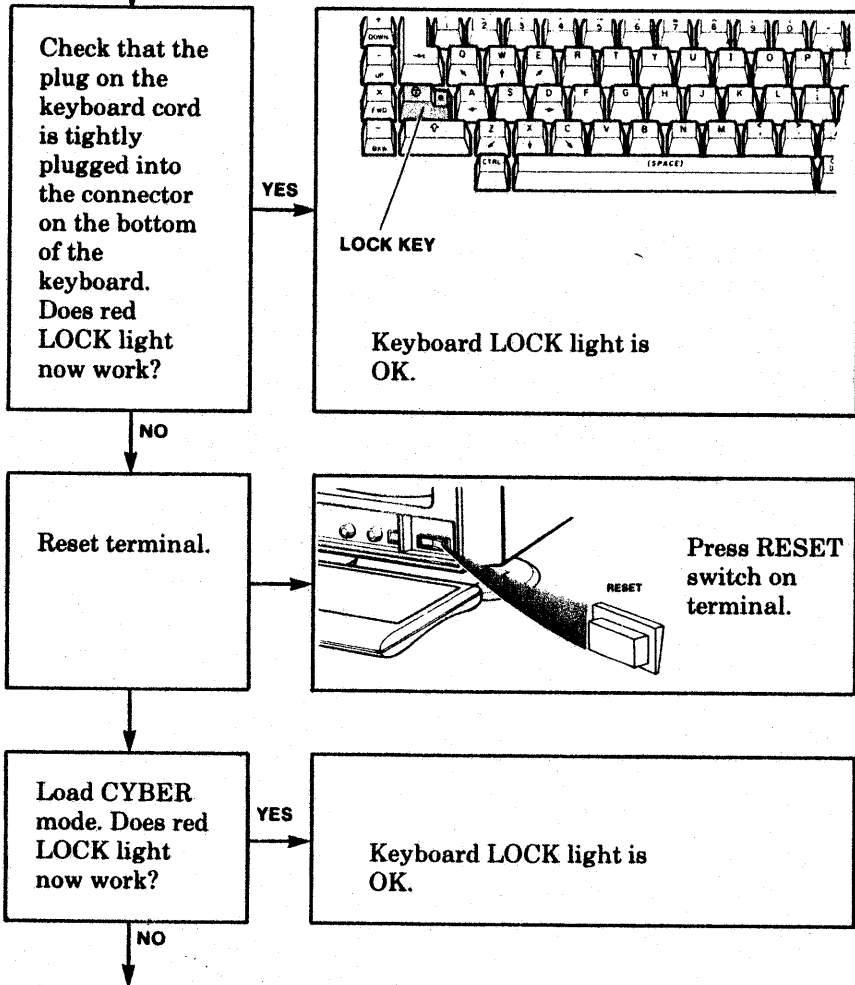

Introduction

These pages give instructions for sending or bringing your terminal to a Control Data Service Center for repair. However, unless you are sure a unit needs repair, there are some things you can still try.

- In case you may have missed some point, go over the HELPs again.
- Look over the manuals that came with your equipment and the manuals for your application; they may solve the problem.
- Ask someone who has been using the terminal if they have had the same problem. They may know the answer.
- Fill out a copy of the Problem Report Form at the end of this guide. It may remind you of something you overlooked—and you will have the information handy if you talk to the HOTLINE or the Service Center.
- Call the Control Data HOTLINE. They may know the answer. The HOTLINE number is:

1-800-ACS-9999, except in Minnesota where the number is 612-482-2739.

- Call the Service Center nearest you. They may be able to help. Telephone numbers of the Service Centers are listed in the pamphlet that came with your display terminal. If you are sending a unit for service, check with the Service Center to see if you should also send related items, such as cables, interface boards, etc.

Turning in Units to a Service Center

Carry-in maintenance agreements are available from Control Data. To get a maintenance agreement, contact your CDC salesperson.

All items turned in, whether in person or by shipment, must be packed in CDC-approved materials. If original packing materials were not saved, approved materials may be obtained through your CDC salesperson. Tell your salesperson the equipment number or part number. There is a charge for packing material.

The following are turn-in items:

- Display terminal: When turned in for service, includes all but the keyboard, equipment interconnecting cables, and the parallel- or serial-interface boards that may be installed.
- Graphics board and 1200/1200-baud internal modem: These boards remain installed in the terminal when turned in for service. If the internal modem is turned in for service, its telephone-line extension cord and duplex adapter are also turned in.
- Keyboard with attached cable
- Printed-circuit boards that may be in slots I/F-1, I/F-2, or I/F-3 at the rear of the terminal

NOTE: A memory module is not turned in to a Service Center. If a memory module does not work, contact your salesperson to order a replacement. Use the part number on the old memory module to order a replacement.

The next paragraphs describe how to prepare these items for turn-in. After that is a listing of information that must accompany turned-in items.

Display Terminal

If you are sure the cables, the keyboard, and the parallel- or serial-interface boards are OK, don't send them with the terminal. If you are unsure, ask the Service Center.

To prepare the display terminal for turn-in:

- 1 Make sure your parameter entries are recorded on the Parameter Records in the Installation Guide. When your terminal returns, you can then re-enter the parameters.
- 2 Turn off power to the terminal and to all items connected to the terminal.
- 3 Disconnect the following:
 - Terminal power cord at both ends
 - Keyboard cable from terminal (look under the terminal and press the plastic clip on the cable from the keyboard. Then, pull the plug out). If you are sending the keyboard, pack it in the original box or an approved replacement. See the Keyboard part of this section.
 - Disconnect any cables from the terminal (you may want to tag the cables to make reconnecting them easier)
- 4 Take out any interface boards (in the I/F-1 through I/F-3 slots at the rear of the terminal) that you are sending by removing the two screws that hold the cover plates of boards to the rear of the terminal. Then pull the boards from the slots. Replace the cover plates.
- 5 If a memory module is installed, remove the screw holding the memory-module cover in place. Remove the cover and carefully pull out the memory module. Replace the cover.

- 6 Pack the display terminal as shown. You should have someone help you. Use the original packing materials or approved replacement materials. Seal the carton with 3-inch box-sealing tape or an equivalent tape.
- 7 Go to Accompanying Information later in this section.

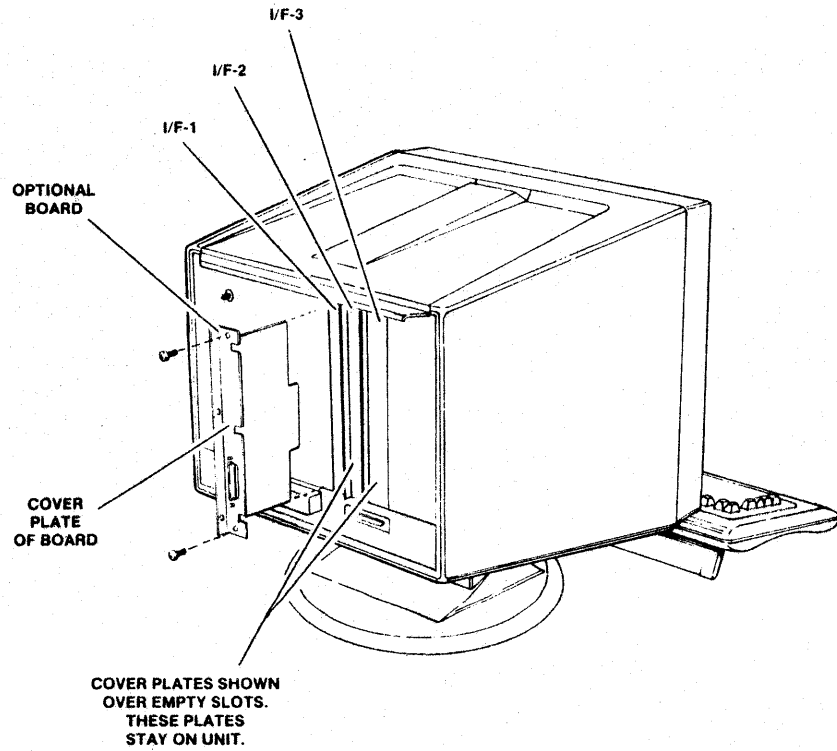

Removing Printed-Circuit Boards

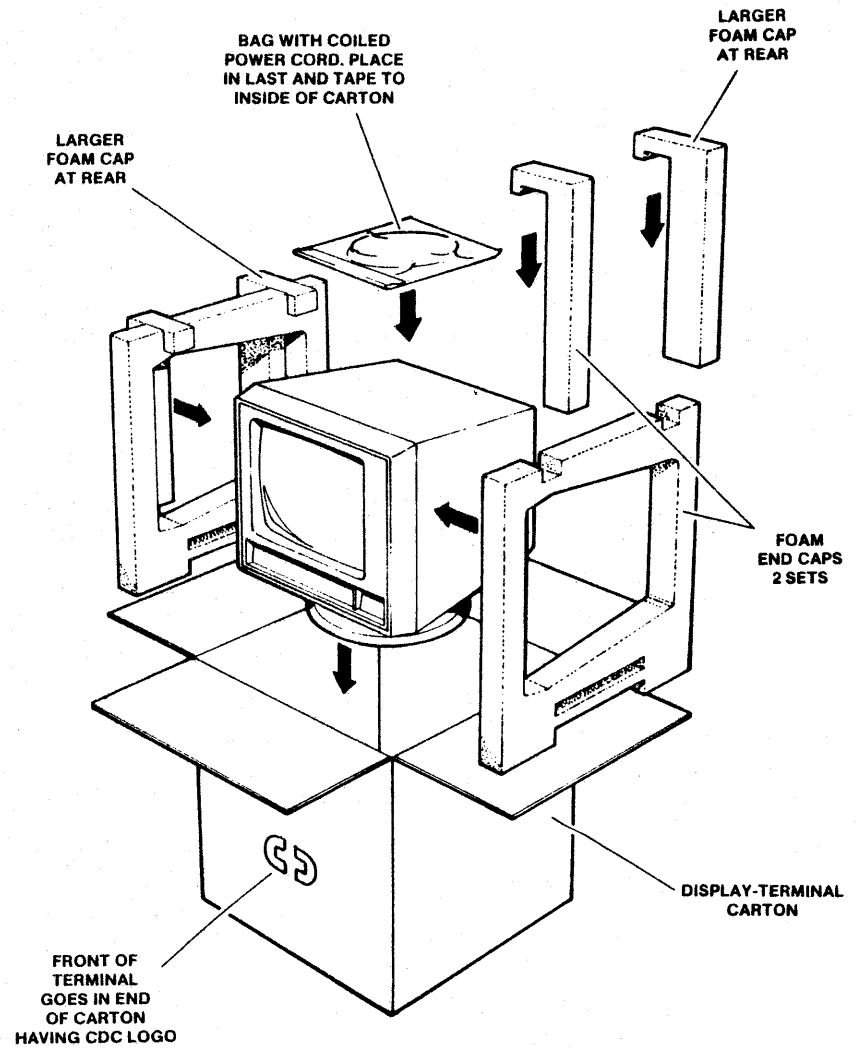

Packing Basic Terminal Unit

Accompanying Information

The following information must accompany the turned-in item:

- The company name and address of the user
- The name and telephone number of the person to be contacted if any questions arise
- A description of the failure that occurred
- The contract number or account number of the maintenance agreement
- A copy of the Problem Report Form

Problem Report Form

It's a good idea to make some copies of the following Problem Report Form and to keep them on hand. Then if you have a problem with your equipment that you cannot solve, you can fill in a copy of the Problem Report Form before calling the Service Center or the HOTLINE. With the form filled in, you will be ready to answer most of the questions they will ask.

If you must send or bring any unit in for service, also send or bring a copy of the form to the Service Center.

Problem Report Form Account or Contract Number _____
 (Fill in the blanks that apply to your system/equipment)

Customer Name _____ Date _____

Address _____

Phone Number _____ Contact _____

Product Name _____

Failing Program _____

Failing Equipment _____

Has this program run successfully before? Yes _____ No _____

Briefly describe the symptoms of the problem and what you were doing:

After going through the "HELP" sections of the software, application, or owner's manual, what did you do to try to solve the problem? _____

If you did not fix the problem, fill in as much detail as you can on this form, then call your marketing or hotline support person for further assistance.

1. List the lights lit at time of failure: _____

2. If the problem appears to be caused by an equipment failure, what equipment is failing? _____

3. Do the switches on the equipment match the original settings? _____
 Were any changed recently? _____

4. Record displayed error messages and/or parameter settings: _____

5. Run the resident equipment self tests; record OK or the failing test data from each equipment. Refer to owner's/user's manuals for help.

Terminal _____
Flexible-Disk Drive _____
Printer _____
Rigid-Disk Drive _____
Other (specify) _____

6. Run the system disk tests; record OK or failing test data. Refer to the owner's/user's manuals for help.

Terminal _____
Flexible-Disk Drive _____
Printer _____
Rigid-Disk Drive _____
Other (specify) _____

7. For problems communicating to a remote computer:

- a. Try another remote computer phone number if possible.
- b. Is the remote computer operating? _____ (call the computer site)
- c. Run a local job or diagnostics to determine condition of your system.
- d. Check phone conditions.

8. Any other helpful observations? _____

TO BE FILLED IN BY REPAIR SERVICE CENTER

Repair Service - Problem Resolution: _____

Return copy to customer and enter on data base.

Other: _____

Terminal Installation Parameters

The following pages give you a complete list of terminal installation parameters. Use this list for reference if your requirements change. If you change any terminal installation parameters, record the changes on the Terminal Installation Parameter Record in the Installation Guide.

The parameters shown in the blocks are the default parameters. Where an X is shown in the blocks, on the screen you will see a 0 if you have a CC634 terminal, or a 1 if you have a CC638 terminal. The position numbers are below the blocks.

F	C	O	N	F	I	G
2	0	X	0	0	0	0
	1	2	3	4	5	6

Terminal Installation Parameter F2

F	CONFIG
2	0X0000

1 2 3 4 5 6

Position

- | | | | |
|---------------------------|---|---|-------------------|
| | 1 | This position is not used. | |
| TOUCHPANEL | 2 | Does your terminal have a touchpanel installed? | Yes = 1
No = 0 |
| SERIAL-INTERFACE BOARD | 3 | Does your terminal have a serial-interface (dual-asynchronous) board installed? | Yes = 1
No = 0 |
| PARALLEL GRAPHICS PRINTER | 4 | Is a parallel-interface graphics printer connected to your terminal? | Yes = 1
No = 0 |
| FLEXIBLE-DISK DRIVE | 5 | Is a flexible-disk drive connected to your terminal? | Yes = 1
No = 0 |
| SERIAL GRAPHICS PRINTER | 6 | Is a serial-interface graphics printer connected to your terminal? | Yes = 1
No = 0 |

Terminal Installation Parameter F3

F	CONFIG
3	00X000

1 2 3 4 5 6

Position

- | | | | |
|--------------------------|---|--|-------------------|
| INTERNAL MODEM | 1 | Does your terminal have a 1200/1200-baud internal modem installed? | Yes = 1
No = 0 |
| | 2 | This position is not used. | |
| GRAPHICS FEATURE | 3 | Does your terminal use a graphics feature? | Yes = 1
No = 0 |
| PARALLEL-INTERFACE BOARD | 4 | Does your terminal have a parallel-interface board installed? | Yes = 1
No = 0 |
| | 5 | This position is not used. | |
| RIGID DISK | 6 | Does your terminal have a rigid disk installed? | Yes = 1
No = 0 |

Terminal Installation Parameter F4

F	CONFIG
4	000000
	1 2 3 4 5 6

Position

AUTO SELECT

- | | | |
|---|--|-----------------------------|
| 1 | Is auto select to be on (enabled) or off (disabled)? If auto select is enabled, the operating mode is automatically loaded when you turn on or reset the terminal. This is convenient when operations are always in one mode. The auto select mode is chosen in F6. If auto select is disabled, the Mode Selection display appears on the screen when you turn on or reset the terminal. | Enabled = 1
Disabled = 0 |
|---|--|-----------------------------|

PRINTER CARRIAGE RETURN

- | | | |
|---|--|-------------------------------|
| 2 | If a serial printer is connected, is a 200-millisecond delay to follow every Carriage Return, Line Feed, and Form Feed sent to the printer if the Secondary Request to Send (SRTS) is in a marking or open condition? If no delay is chosen, no delays will be used when sending data to a serial printer. | Use delay = 1
No delay = 0 |
|---|--|-------------------------------|

MODEM LOOPBACK TEST

- | | | |
|---|---|-------------------|
| 3 | If a 1200/1200-baud internal modem is installed, is its approximately 14-second long loopback test to run with the other modem self tests? The modem self tests run whenever the terminal self test runs. | Yes = 1
No = 0 |
|---|---|-------------------|

TONE/PULSE DIALING

- | | | |
|---|--|-----------------------|
| 4 | If the 1200/1200-baud internal modem is installed, is it to use tone (Touch-Tone) dialing or pulse (dial-phone) dialing? Pulse dialing will work on either type of phone line but is slower to dial. | Tone = 1
Pulse = 0 |
|---|--|-----------------------|

PRINTER DTR

- 5 If a printer is installed, is print data to be sent to it only when it is ready (serial printer issuing a Data Terminal Ready signal, parallel printer issuing a ready status), or is printer readiness to be ignored? This parameter should be enabled for printers that drop their DTR signal or ready status when they are not ready for printing.
- Enabled = 1
Ignore = 0

BIDIRECTIONAL DTR

- 6 If a serial-bidirectional (non-printer) device is installed, is data to be sent to it only when it is issuing a Data Terminal Ready signal, or is the signal to be ignored? This parameter should be enabled for a device that drops its DTR signal when it is not ready.
- Enabled = 1
Ignore = 0

Terminal Installation Parameter F5

F	CONFIG		
5	0	0	0

This block is not used.

Terminal Installation Parameter F6

F	A	S	X	Y
6	0	0	0	
	1	2	3	

Position

AUTO-SELECT MODE

- 1 If the auto-select parameter in F4 is enabled, which one of these modes is to be the auto-select mode? The mode chosen will be automatically loaded when you turn on or reset the terminal.
- 2, 3 Do not make any changes to these positions. Entries are only made here when the display screen needs realignment. (Instructions for realignment are given in Appendix B.)
- CYBER = 0 or 1
PLATO = 2
Mode 3 = 3
Mode 4 = 4
Mode 5 = 5
Mode 6 = 6
Mode 7 = 7

Terminal Installation Parameter F7

F	L	ID			
7	0	0000			
	1	2	3	4	5

Position

KEYCAP KIT

- 1 If you install a keycap kit, this position lets the screen display corresponding characters. The terminal must be reset after this position is changed.

Characters displayed are to be:	Standard	= 0 or 1
	French	= 2
	German	= 3
	Swedish/ Finnish	= 4
	United Kingdom	= 5
	Spanish	= 6
	Danish/ Norwegian	= 7

ID CODE

- 2-5 Is your terminal connected to a computer/network that requires identification (ID) codes? If so, fill in the four digits of the terminal code. The four digits must be from the numbers 0 through 9 and the letters A through F.

Enter the four digits of the terminal code.

Terminal Installation Parameter F8

F	PORT	A
8	0	6
	1	2

Position

PORT A

- 1 This position sets communications guidelines for Port A of the serial-interface board. If a serial-interface (dual-asynchronous) board is not installed, enter an 8 in this position. If a serial-interface board is installed, answer the questions and refer to the table following for the correct entry.

- The item connected to connector J1 (Port A) of the serial-interface board is a:
 - Bidirectional (send and receive) device (no printer) = 1
 - Receive-only printer = 0
- } Column A
- Parity on Port A is to be:
 - Disabled = 1
 - Enabled = 0
- } Column B

NOTE: When information is transmitted it is put into a form that machines can "read." This is done by breaking the information down into bits and calling each bit a 0 or a 1. Parity is a method used to detect errors when information is transmitted. This is done by including an extra bit (a 0 or 1) for each byte (normally 8 bits long) that is transmitted, so that each byte always has either an odd or even number of bits. Errors are detected by a parity check when the information is received.

- If parity is enabled on Port A, parity is to be:
 - Even (even number of bits) = 1
 - Odd (odd number of bits) = 0
- } Column C
- If parity is disabled on Port A and a bit is to be inserted in the parity bit position, is the inserted bit to be a mark or a space?
 - Mark = 1
 - Space or not applicable = 0
- } Column C
- Excluding parity or inserted mark or space, words in Port A communications are to have:
 - Eight data bits = 1
 - Seven data bits = 0
- } Column D

A B C D ENTER

0 0 0 0 = 0
 0 0 0 1 = 1
 0 0 1 0 = 2
 0 0 1 1 = 3
 0 1 0 0 = 4
 0 1 0 1 = 5
 0 1 1 0 = 6
 0 1 1 1 = 7
 1 0 0 0 = 8
 1 0 0 1 = 9
 1 0 1 0 = A
 1 0 1 1 = B
 1 1 0 0 = C
 1 1 0 1 = D
 1 1 1 0 = E
 1 1 1 1 = F

PORT A BAUD RATE

- 2 This position is used to choose the baud rate for Port A. The baud rate on Port A is to be:

75 b/s = 0
 110 b/s = 1
 150 b/s = 2
 200 b/s = 3
 300 b/s = 4
 600 b/s = 5
 1200 b/s = 6
 1800 b/s = 7
 2400 b/s = 8
 4800 b/s = 9
 9600 b/s = A
 19 200 b/s = B

Terminal Installation Parameter F9

F	PORT B
9	A 6

1 2

Position

PORT B

- 1 This position sets communications guidelines for Port B of the serial-interface board. If a serial-interface (dual-asynchronous) board is not installed, enter an 8 in this position. If a serial-interface board is installed, answer the questions and refer to the table following for the correct entry.

- The item connected to connector J2 (Port B) of the serial-interface board is a:

- Bidirectional (send and receive) device (no printer) = 1
 - Receive-only printer = 0
- } Column A

- Parity on Port B is to be:

- Disabled = 1
 - Enabled = 0
- } Column B

NOTE: When information is transmitted, it is put into a form that machines can "read." This is done by breaking the information down into bits and calling each bit a 0 or a 1. Parity is a method used to detect errors when information is transmitted. This is done by including an extra bit (a 0 or 1) for each byte (normally 8 bits long) that is transmitted, so that each byte always has either an odd or even number of bits. Errors are detected by a parity check when the information is received.

- If parity is enabled on Port B, parity is to be:

- Even (even number of bits) = 1
 - Odd (odd number of bits) = 0
- } Column C

- If parity is disabled on Port B and a bit is to be inserted in the parity bit position, is the inserted bit to be a mark or a space?

- Mark = 1
 - Space or not applicable = 0
- } Column C

- Excluding parity, words in Port B communications are to have:

- Eight data bits = 1
 - Seven data bits = 0
- } Column D

<u>A</u>	<u>B</u>	<u>C</u>	<u>D</u>	<u>ENTER</u>
0	0	0	0	= 0
0	0	0	1	= 1
0	0	1	0	= 2
0	0	1	1	= 3
0	1	0	0	= 4
0	1	0	1	= 5
0	1	1	0	= 6
0	1	1	1	= 7
1	0	0	0	= 8
1	0	0	1	= 9
1	0	1	0	= A
1	0	1	1	= B
1	1	0	0	= C
1	1	0	1	= D
1	1	1	0	= E
1	1	1	1	= F

PORT B BAUD RATE

2 This position is used to choose the baud rate for Port B. The baud rate on Port B is to be:

- 75 b/s = 0
- 110 b/s = 1
- 150 b/s = 2
- 200 b/s = 3
- 300 b/s = 4
- 600 b/s = 5
- 1200 b/s = 6
- 1800 b/s = 7
- 2400 b/s = 8
- 4800 b/s = 9
- 9600 b/s = A
- 19 200 b/s = B

Mode Installation Parameters

The following pages give you a complete list of mode installation parameters. Use this list for reference if your requirements change. If you change any mode installation parameters, record the changes on the Mode Installation Parameter Record in the Installation Guide.

Each mode to be used (except Mode 7) requires a separate set of mode installation parameters. The parameters shown in the blocks are the default parameters for each of the modes 1 through 5. Mode 6 has no default parameters as this mode is user-assigned. The position numbers are shown below the blocks.

		CYBER					
F	2	1	0	0	0	0	0
		1	2	3	4	5	6

Mode Installation Parameter F2

MODE 1	MODE 2	MODE 3	MODE 4	MODE 5
CYBER	PLATO	CP/M	DISK	C120
F CONFIG	F CONFIG	F CONFIG	F CONFIG	F CONFIG
2 100000	2 100100	2 100110	2 100110	2 100000
1 2 3 4 5 6	1 2 3 4 5 6	1 2 3 4 5 6	1 2 3 4 5 6	1 2 3 4 5 6

Position

MODE ON/OFF

- 1 Is this mode to be on (enabled) or off (disabled)? If the mode is disabled, it cannot be used. The alarm sounds, and FAILURE LOADING MODE appears on the screen if an attempt is made to use the mode. The other positions in this block may be set so that if the mode is enabled at some point, it is only necessary to change this position.
- Enabled = 1
Disabled = 0

ACCESS CODE REQUIRED

- 2 Is the entry of an access code to be required before this mode can be used? If entry is required, only persons who know the access code can use the mode. The access code is recorded in F10.
- Yes = 1
No = 0

AUTOMATIC LOAD SOURCE/OPERATOR SELECT

- 3 Are the source (disk, host computer, memory module), file, and phone number (only if you have a 1200/1200 internal modem) for program loading to be selected by the operator or automatically selected?
- By operator = 1
Automatically = 0

LOAD EXTERNAL/INTERNAL

- 4 Is this mode to load from an external source (disk or host computer) or load from an internal source (CYBER mode or mode loaded from a memory module)? If this mode is to load internally, either CYBER or memory module is selected in F5, position 6.
- Load external = 1
Load internal = 0

LOAD DISK/HOST 5 If load external Disk = 1
 is selected, is Host computer = 0
 loading to be
 from a disk or
 host computer?

**LOAD VIA INTERNAL 6 If load from Modem = 1
 MODEM/DATA SET host computer is DATA SET = 0
 CONNECTOR selected, are communications
 to be via the
 1200/1200-baud
 internal modem
 or the terminal's
 DATA SET
 connector (RS-
 232-C
 interface)?**

Mode Installation Parameter F3

MODE 1	MODE 2	MODE 3	MODE 4	MODE 5										
CYBER	PLATO	CP/M	DISK	C120										
F <table border="1"><tr><td>CONFIG</td></tr><tr><td>000110</td></tr></table>	CONFIG	000110	F <table border="1"><tr><td>CONFIG</td></tr><tr><td>000110</td></tr></table>	CONFIG	000110	F <table border="1"><tr><td>CONFIG</td></tr><tr><td>000100</td></tr></table>	CONFIG	000100	F <table border="1"><tr><td>CONFIG</td></tr><tr><td>000110</td></tr></table>	CONFIG	000110	F <table border="1"><tr><td>CONFIG</td></tr><tr><td>000000</td></tr></table>	CONFIG	000000
CONFIG														
000110														
CONFIG														
000110														
CONFIG														
000100														
CONFIG														
000110														
CONFIG														
000000														
1 2 3 4 5 6	1 2 3 4 5 6	1 2 3 4 5 6	1 2 3 4 5 6	1 2 3 4 5 6										

Position

**DIAL
 ONCE/CONTINUOUSLY**

1 If a 1200/1200- Continuously = 1
 baud internal Once = 0
 modem is
 installed, is it to
 dial once or
 continuously
 until a
 connection is
 made? With
 continuous
 dialing, the
 modem calls the
 first specified
 number, and if
 no connection is
 made, calls the
 second specified
 number. If no
 connection is
 made with the
 second number,
 the modem
 retrys the first
 number. This
 cycle continues
 until a
 connection is
 made, the
 terminal is
 reset, or the M
 REL/BREAK
 key is pressed.

Mode Installation Parameter F4

MODE 1 CYBER	MODE 2 PLATO	MODE 3 CP/M	MODE 4 DISK	MODE 5 C120
F CONFIG	F CONFIG	F CONFIG	F CONFIG	F CONFIG
4 000000	4 000001	4 000000	4 000001	4 000000
1 2 3 4 5 6	1 2 3 4 5 6	1 2 3 4 5 6	1 2 3 4 5 6	1 2 3 4 5 6

Position

SWITCHED/CONSTANT
DTR

1 If host communications are via an external modem, is the Data Terminal Ready (DTR) signal to the modem to be constantly on or switched off when the mode is offline? If DTR is switched off, received data is ignored by the terminal.

Switched DTR = 1
Constant DTR = 0
Not applicable = 0

SWITCHED/CONSTANT
RTS

2 If host communications are via an external modem, is the Request to Send (RTS) signal to the modem to be constantly on except when DTR or Data Set Ready (DSR) signals drop or is Request to Send (RTS) to be switched on and off according to the following guidelines?

Switched RTS = 1
Constant RTS = 0
Not applicable = 0

TYPEMATIC

- If full-duplex routing is used (half/full duplex is selected in block F6), a switched RTS is on until offline is selected.
- If half-duplex routing is used, a switched RTS goes on with the first keyboard entry and off:
 - Upon receiving a break. A break is a word containing a spare in the stop-bit position.
 - During local operations.
 - Following the transmission of a CR, LF, ACK, or NAK code.
- 3 Are data-entry and control keys to be typematic (start repeating when pressed for longer than a second)?
 - No = 1
 - Yes = 0

CURSOR
STAY/ADVANCE

3 The cursor automatically advances to the beginning of the next line when keyboard entries fill a line. Is this also to be done when data from the host fills a line or is the cursor to stay at the end of a line until advanced by the host?

Stay = 1
Advance = 0

4 This position is not used.

5 This position is not used.

LOAD CYBER/MEMORY
MODULE

6 If load internal is selected in block F2, position 4, is control to be passed to CYBER mode or a memory module?

Memory module = 1
CYBER mode = 0

Mode Installation Parameter F6

	MODE 1 CYBER	MODE 2 PLATO	MODE 3 CP/M	MODE 4 DISK	MODE 5 C120
F	OPR DF	OPR DF	OPR DF	OPR DF	OPR DF
6	4 C 0 4	6 C 2 4	6 C 2 5	6 C 2 4	6 4 4 2 1
	1 2 3 4	1 2 3 4	1 2 3 4	1 2 3 4	1 2 3 4

The parameters in this block are default parameters that are the initial operator parameters when a mode is selected. These parameters may be temporarily changed by the operator or host computer (see the Operating Guide for more information on operator parameters). For a mode other than CYBER, use of the default parameters is program-dependent, and some default parameters may be ignored.

Position

OPERATOR
PARAMETERS

1 Answer the questions and refer to the table following for the correct entry.

- Is the terminal to assume a local or online state after the mode is entered? A local state disables transmission to the host computer. It is possible to receive data while in a local state if constant DTR is selected in F4, position 1.

— Local = 1
— Online = 0

} Column A

- If a printer is connected, is printing of received and transmitted data to be initially on (enabled) when this mode is entered? When printing is enabled, all data sent or received in character mode will be printed while it is being displayed.

-- Yes = 1
 -- No = 0
 -- Does not apply = 0

} Column B

- Is the alarm to sound when keyboard entries advance the cursor to the eighth position from the end of a line or to the last line?

-- Yes = 1
 -- No = 0

} Column C

- Is the terminal alarm to be loud or soft?

-- Loud = 1
 -- Soft = 0

} Column D

A	B	C	D	ENTER
0	0	0	0	= 0
1	0	0	0	= 1
0	1	0	0	= 2
1	1	0	0	= 3
0	0	1	0	= 4
1	0	1	0	= 5
0	1	1	0	= 6
1	1	1	0	= 7
0	0	0	1	= 8
1	0	0	1	= 9
0	1	0	1	= A
1	1	0	1	= B
0	0	1	1	= C
1	0	1	1	= D
0	1	1	1	= E
1	1	1	1	= F

OPERATOR
PARAMETERS

Position

- 2 Answer the questions and refer to the table following for the correct entry.

- Is the LOCK key  to work as a normal shift lock, or is it to limit only letters to uppercase?

-- Normal shift lock = 1
 -- Only letters = 0

} Column A

- Are the 13 keys in the numeric pad on the right side of the keyboard to operate in uppercase only or both uppercase and lowercase?

-- Uppercase only = 1
 -- Both uppercase and lowercase = 0

} Column B

- Is the display screen to operate in a roll or page manner? This choice is independent of the cursor home position selected in F4. In CYBER mode, select roll if compatibility with a CDC 722-10 TTY Display Terminal is desired.

-- Roll = 1
 -- Page = 0

} Column C

- In CYBER mode, are keycodes and reaction to receive codes to be for a CYBER 120 series system (small) or a CYBER 170 series system (large)?

-- CYBER 170 (large) = 1
 -- CYBER 120 (small) = 0

} Column D

A	B	C	D	ENTER
0	0	0	0	= 0
1	0	0	0	= 1
0	1	0	0	= 2
1	1	0	0	= 3
0	0	1	0	= 4
1	0	1	0	= 5
0	1	1	0	= 6
1	1	1	0	= 7
0	0	0	1	= 8
1	0	0	1	= 9
0	1	0	1	= A
1	1	0	1	= B
0	0	1	1	= C
1	0	1	1	= D
0	1	1	1	= E
1	1	1	1	= F

Position

OPERATOR
PARAMETERS

3 Answer the questions and refer to the table following for the correct entry.

- Is the screen to show dark characters on a light background (inverse video) or light characters on a dark background?
 - Light background = 1
 - Dark background = 0
- } Column A
- Is the cursor to appear as a solid block or an underline?
 - Block = 1
 - Underline = 0
- } Column B
- Is the cursor to be steadily lit or blinking?
 - Steadily lit = 1
 - Blinking = 0
- } Column C

- Column D position is not used = 0 } Column D

A	B	C	D	ENTER
0	0	0	0	= 0
1	0	0	0	= 1
0	1	0	0	= 2
1	1	0	0	= 3
0	0	1	0	= 4
1	0	1	0	= 5
0	1	1	0	= 6
1	1	1	0	= 7

Position

4 Answer the questions and refer to the table following for the correct entry.

- Is keyboard-entered data to be displayed at the same time as it is transmitted (half-duplex routing) or is it to be echoed back by the host computer before being displayed (full-duplex routing)?
 - Full duplex = 1
 - Half duplex = 0
- } Column A
- Is the screen to display 80 or 132 maximum characters per line? If the terminal uses a graphics feature, 80 characters must be selected.
 - 132 characters = 1
 - 80 characters = 0
- } Column B
- Is the screen to use 24 or 30 lines for displaying characters?
 - 30 lines = 1
 - 24 lines = 0
- } Column C

OPERATOR
PARAMETERS

- This selection governs a test feature that makes received and keyboard-entered control codes transparent to the terminal. This means that symbols for the control codes are displayed on the screen instead of the control functions being performed.

— Transparent feature on = 1
 — Normal operation = 0 } Column D

A	B	C	D	ENTER
1	0	1	0	
0	0	0	0	= 0
1	0	0	0	= 1
0	1	0	0	= 2
1	1	0	0	= 3
0	0	1	0	= 4
1	0	1	0	= 5
0	1	1	0	= 6
1	1	1	0	= 7
0	0	0	1	= 8
1	0	0	1	= 9
0	1	0	1	= A
1	1	0	1	= B
0	0	1	1	= C
1	0	1	1	= D
0	1	1	1	= E
1	1	1	1	= F

Mode Installation Parameter F7

MODE 1	MODE 2	MODE 3	MODE 4	MODE 5
CYBER	PLATO	CP/M	DISK	C120
F A-DIAL	F A-DIAL	F A-DIAL	F A-DIAL	F A-DIAL
7 000000	7 000000	7 000000	7 000000	7 000000

AUTO-DIAL
PHONE NUMBER

This block is only used if the auto-dial feature of the 1200/1200-baud internal modem is enabled (F3, position 2). The block contains the first 6 digits of the default auto-dial number. F8 contains the last six digits of the number. You can use the digits 0 through 9, and A through F. The digits 0 through 9 are numeric entries, B is tone dial *, C is tone dial #, D pauses until a tone is detected on the line, E delays the dialing sequence until no tone is detected for 3 seconds, and F ends an auto-dial number that does not fill the entire 12 digits of F7 and F8. If space permits, two auto-dial numbers may be entered in the 12-digit field. If this is done, enter an A after the first number.

Mode Installation Parameter F8

MODE 1	MODE 2	MODE 3	MODE 4	MODE 5
CYBER	PLATO	CP/M	DISK	C120
F A-DIAL	F A-DIAL	F A-DIAL	F A-DIAL	F A-DIAL
8 000000	8 000000	8 000000	8 000000	8 000000

AUTO-DIAL
PHONE NUMBER

This block is only used if the auto-dial feature of the 1200/1200-baud internal modem is enabled (F3, position 2). This block contains the last six digits of the default auto-dial number. If the number contains less than 12 digits, end the number with an F.

Mode Installation Parameter F9

MODE 1	MODE 2	MODE 3	MODE 4	MODE 5
CYBER	PLATO	CP/M	DISK	C120
F DF T R	F DF T R	F DF T R	F DF T R	F DF T R
9 00 6 6	9 08 6 6	9 00 6 6	9 00 6 6	9 00 6 6
1 2 3 4	1 2 3 4	1 2 3 4	1 2 3 4	1 2 3 4

Position

FILE NUMBER

- 1, 2 If program loading is from a host computer (F2, position 5), this position contains the file number for the program. The number must not exceed 7F. If file selection is to be automatic (F2, position 3), your terminal will always load this file from the host computer. If file selection is operator-selected, the number in this position should be the normal file number for the mode. This permits the operator to select the file by pressing the NEXT key.
- File number = -- --
Does not apply = 00

TRANSMIT RATE

- 3 Data is to be transmitted to the host computer at:
- 75 b/s = 0
 - 110 b/s = 1
 - 150 b/s = 2
 - 200 b/s = 3
 - 300 b/s = 4
 - 600 b/s = 5
 - 1200 b/s = 6
 - 1800 b/s = 7
 - 2400 b/s = 8
 - 4800 b/s = 9
 - 9600 b/s = A
 - 19 200 b/s = B

RECEIVE RATE

- 4 Data is to be received from the host computer at:
- 75 b/s = 0
 - 110 b/s = 1
 - 150 b/s = 2
 - 200 b/s = 3
 - 300 b/s = 4
 - 600 b/s = 5
 - 1200 b/s = 6
 - 1800 b/s = 7
 - 2400 b/s = 8
 - 4800 b/s = 9
 - 9600 b/s = A
 - 19 200 b/s = B

Mode Installation Parameter F10

MODE 1	MODE 2	MODE 3	MODE 4	MODE 5
CYBER	PLATO	CP/M	DISK	C120
F ACCESS	F ACCESS	F ACCESS	F ACCESS	F ACCESS
10 0000	10 0000	10 0000	10 0000	10 0000

ACCESS CODE

If an access code is required before using this mode (F2, position 2), enter the assigned four digit code.

Screen Realignment without a Touchpanel Installed

The following instructions apply if the area of the screen that can be displayed has drifted off center. If realignment does not correct this condition, the display terminal may need service. (Refer to **HELP 100** for instructions on turning the terminal in for service.)

NOTE: Before determining if adjustment is necessary, allow the terminal to warm up for approximately 15 minutes.

To realign the screen, follow these steps.

- 1** If the Operation Test display is on your screen, skip to step 3. If the Operation Test display is not on your screen:
 - If your terminal is in CYBER mode, press the **SETUP** key. Then press the **F10** key twice.
 - If your terminal is not in CYBER mode, and you are able to select your operating mode, press **RESET**.
 - If your terminal is not in CYBER mode, and is set up for automatic selection of the operating mode, pull out the **TEST** switch at the back of the terminal. Then press **RESET**. Disregard the **TEST SWITCH ENABLED** message that appears with the Mode Selection display. Push the **TEST** switch back in.
- 2** Press the **F8** key to select **TERMNL TEST**. (If your terminal has a graphics feature, press the **F8** key again.) The Operation Test display then appears on your screen.

3 The notches in the corners of the screen bezel indicate where the middle of the border lines should be displayed on the screen. Use the notches as a guide and estimate the required realignment as follows:

- If the border line is off center horizontally, estimate how many character positions the border should move to the right or left.
- If the border line is off center vertically, estimate how many scan lines the border should move up or down. To see the scan lines on the screen, temporarily turn the BRIGHTNESS control all the way clockwise.

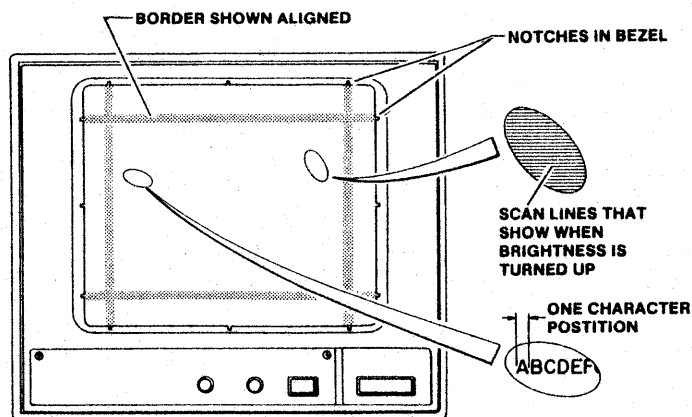

- 4** Make the Mode Selection display appear on your screen. (See step 1.)
- 5** With the Mode Selection display on the screen, press the CTRL key at the same time as the SETUP key. The terminal installation parameters then appear on the screen.
- 6** Press the F6 key. Use the space bar to move the cursor under X if horizontal realignment is needed, or under Y if vertical realignment is needed.
- 7** Refer to the following tables for the correct entry.

HORIZONTAL REALIGNMENT (X)

ENTRY	DIRECTION	NUMBER OF CHARACTER POSITIONS
0	—	NONE
1	RIGHT	1
2	RIGHT	2
3	RIGHT	3
4	—	NONE
5	LEFT	1
6	LEFT	2
7	LEFT	3

VERTICAL REALIGNMENT (Y)

ENTRY	DIRECTION	NUMBER OF SCAN LINES
0	—	NONE
1	UP	1
2	UP	2
3	UP	3
4	UP	4
5	UP	5
6	UP	6
7	UP	7
8	—	NONE
9	DOWN	1
A	DOWN	2
B	DOWN	3
C	DOWN	4
D	DOWN	5
E	DOWN	6
F	DOWN	7

- 8** After you have made the necessary entries, press the COPY key.
- 9** Press the F1 key to return to the Mode Selection display. Then press the F8 key to put the Operation Test display on your screen. (If your terminal has a graphics feature, press the F8 key again.)
- 10** Check the alignment of the border lines with the notches in the bezel. If further correction is needed, go back to step 3 and repeat the procedure.

Screen Realignment with a Touchpanel Installed

The following instructions apply if the area of the screen that can be displayed has drifted off center. If realignment does not correct this condition, the display terminal may need service. (Refer to **HELP 100** for instructions on turning the terminal in for service.)

NOTE: Before determining if adjustment is necessary, allow the terminal to warm up for approximately 15 minutes.

To realign the screen, follow these steps.

- 1** If your terminal is in CYBER mode, skip to step 3. If your terminal is not in CYBER mode:
 - If you are able to select your operating mode, press **RESET**.
 - If your terminal is set up for automatic selection of the operating mode, pull out the **TEST** switch at the back of the terminal. Then press **RESET**. Disregard the **TEST SWITCH ENABLED** message that appears with the Mode Selection display. Push the **TEST** switch back in.
- 2** Press the **F1** key to select **CYBER** mode.
- 3** Press the **SETUP** key to show the first display of Operator parameters.
- 4** Select the following conditions on the display:
 - **LINE (OFF):** Use the **F2** key to select offline operation of the terminal.
 - **SCREEN (PAGE):** Use the **F8** key to select page-mode operation of the terminal display screen.
 - **MORE SELECT:** Use the **F10** key to advance to the second display of Operator parameters.

- **BACKGD (LIGHT):** Use the **F2** key to select inverse video so that dark characters appear on a light background.
- **CURSOR (BLOCK):** Use the **F3** key to select the block type of cursor.
- **CURSOR (SOLID):** Use the **F4** key to select the nonblinking type of cursor.
- **CHR/LN (80):** Use the **F7** key to select 80 characters per display line.
- **LINES (30):** Use the **F8** key to select 30 lines per display page.

- 5** Press the **F1** key to return to **CYBER** mode.
- 6** Enable the terminal touchpanel by pressing:
 - CTRL, SHIFT, and + keys (3 keys) all at the same time**
 - CTRL, SHIFT, and R keys (3 keys) all at the same time**
 - SHIFT and R keys (2 keys) at the same time**
- 7** Turn the **BRIGHTNESS** and **CONTRAST** controls fully clockwise to check whether the vertical and horizontal grid lines of the touchpanel are visible. Having both the vertical and horizontal grid lines for reference simplifies things a little, but the procedure is essentially the same whether both are visible or not.
- 8** Press the Shift key (**↑**) together with the **HOME** key to move the cursor to the upper left corner of the screen.
- 9** Key in 1234567890 on the first line of the screen.
- 10** Press the Shift key together with the **HOME** key to move the cursor to the upper left corner of the screen.
- 11** Press the Shift key together with the **Cursor-Up** key (**↑**) to move the cursor to the lower left corner of the screen.
- 12** Key in 1234567890 on the 30th line of the screen.
- 13** Press the Shift key together with the **HOME** key to move the cursor to the upper left corner of the screen.

- 14 Hold the Shift key down and press the Cursor-Down key (↓) 14 times to move the cursor to the vertical center of the screen.
- 15 Key in 1234567890 four times across the center of the screen.
- 16 Verify that the entries made in the preceding steps leave the screen appearing as shown below. Note that the H's shown will be added later.

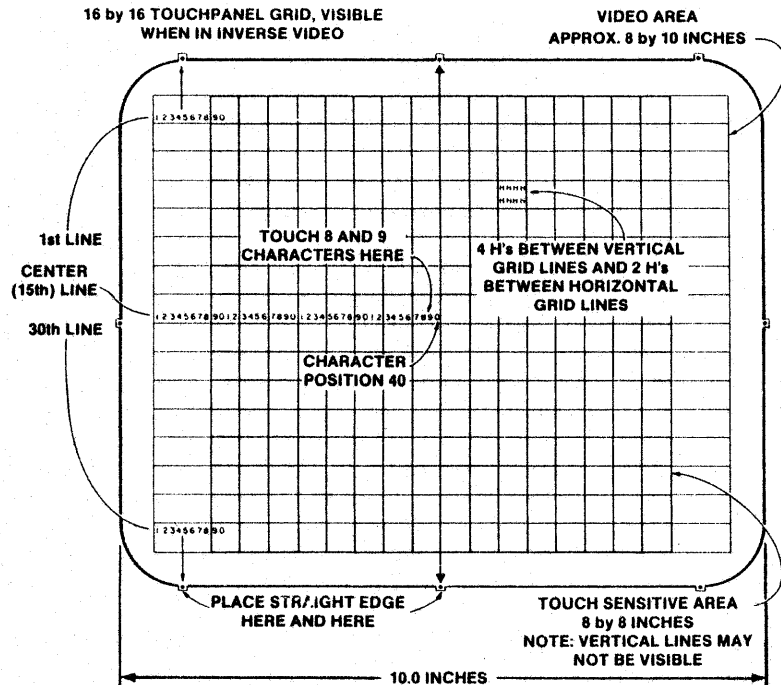

- 17 Check the vertical relationship of the touchpanel to the display as follows. The first row of characters should appear to rest just above the first horizontal grid line on the touchpanel. The second row of characters should appear to rest just above the eighth horizontal grid line on the touchpanel. The third row of characters should appear to hang just below the last horizontal grid line on the touchpanel. If all three lines of characters are uniformly too high or too low, use the keyboard input technique described in the preceding procedure to correct the problem.

- 18 Check the horizontal relationship of the touchpanel to the display as follows. Place the edge of a piece of paper or another straight edge between the top and bottom alignment notches toward the left side of the screen bezel (see previous illustration). The edge of the paper should just cover the 5 column in all three test display rows, leaving the 1234 columns of all three rows visible to the left of the straight edge. Moving the straight edge over to the middle upper and lower alignment notches in the bezel should leave the last 0 character in the middle row of the test display just visible to the left of the straight edge. If these two checks reveal that the display columns are uniformly too far left or too far right, use the keyboard input technique described in the preceding procedure to correct the problem.
- 19 Using a soft blunt object, such as the eraser on a pencil or your finger, touch the rightmost 8 and 9 numbers in the center line of characters on the screen. The cursor should position itself over the number 9. If the cursor is off by more than one character position left or right, it requires adjustment. Adjust the cursor position using the keyboard input technique described in the preceding procedure.
- 20 If both horizontal and vertical grid lines of the touchpanel are visible, the following checks may also be performed. Check that four H characters fit between any two adjacent vertical grid lines on the touchpanel, and check that two H characters placed one immediately above the other fit between any two adjacent horizontal grid lines on the touchpanel. If these checks are not correct, use the keyboard input technique described in the preceding procedure to move the display in the correct direction.

Index

A

- Access code 3-26
- Access cover 2-2-6
- Access door (flexible-disk drive) 3-39
- Access-cover latch 3-14
- Accompanying information 5-8
- Additional space 1-4
- Air circulation 1-4
- Alarm 3-14
- Alignment border 2-1-11
- Alphanumeric characters 2-4-14
- Angle
 - Keyboard 3-20
 - Screen 3-20
- Auto dial 2-4-22
- Auto-answer mode 3-30
- Auto-dial phone number 2-4-22, 2-4-23
- Automatic method 2-4-19, 2-4-21
- Automatic-tabbing 3-58

B

- Battery 4-3
- Battery cover plate 3-15
- Baud rate 3-52
- Beep 3-14
- Bell 212A 2-3-7, 3-32
- Bezel 4-24
- Block-transmit mode 3-54
- Break signal 3-60
- BRIGHTNESS control 3-11

C

- Cable (interconnect) 2-2-9
- Cable (YA255) 2-3-7, 2-3-16
- Canadian Department of Communications Guidelines 2-3-4
 - Label 2-2-10
- C120 2-4-17
- CB1 circuit breaker 3-12

- CC634 2-1-9
- CC638 2-1-9, 2-1-16
- CDC 110 Microcomputer System
 - 1-1, 2-4-3, 2-4-22, 3-23
- Changing Parameters 3-43
- Character-transmit mode 3-54
- Circuit breaker 3-12
- Cleaning 3-67
- Cleaning supplies 1-7
- Combination method 2-4-18, 2-4-20
- Communications circuits 2-1-16
- Computer
 - Local 2-3-16
 - Remote 3-30
 - Network 3-25
- Confirmation tone 3-33
- Connector
 - DATA SET 2-3-8, 2-3-16
 - J1 2-3-17
 - J2 2-3-17
 - Keyboard 2-1-3
 - Memory Module 2-2-39
 - Power 3-14
 - RJ11C 2-3-5
- Connectors 2-3-2
- Continuous (dialing) 2-4-23
- CONTRAST Control 3-11
- Control Data HOTLINE 4-1
- Control Data Service Center 4-1, 5-1
- Control Data Services Network (CDSN) 2-4-17
- CP/M 2-4-3, 2-4-22, 3-21
- Cursor 3-7
- CYBER 3-47
- CYBER - mode test 3-66
- CYBER 120 series system 3-51
- CYBER 170 series system 3-51
- CYBERNET 2-4-17

D

Danish (keyboard) 3-17
 Data-entry 3-18
 DATA SET connector 2-3-8, 2-3-16
 Default mode installation
 parameter record 2-4-15
 Default parameters 2-4-2, 2-4-4,
 2-4-12
 Delete code 3-59
 Dial tone 2-4-22
 Dimensions 1-4
 Disconnection
 Internal modem 3-29
 External modem 3-34
 DISK 2-4-12
 Disk drive 3-38
 Display terminal 3-2
 Dual-asynchronous interface
 2-2-35
 Duplex adapter 2-3-3

E

Egg-crate covers 1-5
 Electrical power outlet 1-6
 Equipment identification number
 2-1-2
 Equipment tag 2-1-2
 Escape code 3-60
 Extension cord (telephone line)
 2-3-3

F

F key identifiers 3-22
 F keys 3-22
 F numbers 2-4-5
 FCC label 2-2-10
 FCC registration number 2-3-3
 File number 2-4-21
 Finnish (keyboard) 3-16
 Flexible disk 3-38
 Flexible-disk drive 3-38
 French (keyboard) 3-16
 Full-duplex routing 3-52
 Fuse box 1-6
 401X Graphics Memory Module
 2-2-39

G

German (keyboard) 3-16
 Graphics board
 Installation 2-2-19
 Checkout 2-2-27
 Graphics feature 3-7

H

HELP section 4-1, 5-1
 HELPS
 Display terminal 4-12
 Keyboard 4-30
 100 5-1
 Host computer 3-52
 HOTLINE 4-1
 Humidity 1-2

I

I/F-1 2-2-32
 I/F-2 2-2-36
 I/F-4 2-2-10
 Installation parameters 2-4-2
 Installation record 2-2-45
 Inverse video 3-53

J

Jumper (graphics board) 2-2-24
 Jumper cable 2-2-3

K

Key-Code Table 4-26
 Keyboard 2-1-3, 3-18
 Keyboard cable 1-9
 Keyboard test 4-30
 Keycap kit 2-2-43
 Keycaps 3-15
 Keys
 Backspace 2-4-5
 COPY 2-4-11
 CR/DEL 3-57
 CTRL 3-58, 3-60
 ERASE 3-59
 F1 2-4-16
 F8 2-1-10
 F10 2-4-12
 L/DLETE/C 3-59

LF/ESC 3-60

L/INSRT/C 3-59

Lock 3-19

MREL/BREAK 2-4-27, 3-31,
 3-60

NEXT 3-58

P/CLEAR/EOL 3-58, 3-60

PRINT 3-60

SETUP 3-44, 3-48

Shift 3-19, 3-50

Space bar 2-4-6

L

Latch 3-14

Leg (keyboard) 3-21

Lighted blocks 2-1-10

Lighting 1-5

Lights

 ALERT 3-13

 DATA SET READY 3-14

 ERROR 3-13

 LOCK 3-13

 MESSAGE 3-13

 POWER (flexible-disk drive)
 3-39

 PROGRAM 1, 2, 3 3-13

Line-drawing 3-61

Load source 2-4-17

Loading 3-2

Local Computer 2-3-16

Loopback test 2-4-8

M

Main logic board 2-2-24

Maintenance agreement 5-2

Manual method 2-4-17, 2-4-18

Manual release 3-60

Memory module 2-2-39, 2-4-24, 3-42

Messages

 BATTERY LOW 3-43, 4-2

 Blank 4-2

 BLINK 2-1-11

 BLOCK 0 3-23

 BUSY 3-30

 COMM FAIL 4-2

 CHARACTER RAM FAIL 4-2

 COMM RUNNING 2-1-17

COPYRIGHT CONTROL

 DATA 198X 4-3

 DIALING ERROR 3-27

 DIALING PHONE NUMBER
 3-26

 DIM 2-1-11

 DISK LOAD FAIL 3-41, 4-5

 ENTER ACCESS CODE 3-26

 ENTER MODE n (1-6) 2-4-12

 ENTER MODE NAME 2-4-13

 ENTER PHONE NUMBER
 3-26

 EXT KBD LOOPBACK FAIL
 4-2

 FAILURE LOADING MODE
 3-26, 4-6

 GRAPHIC FAIL 4-8

 GRAPHICS X.X 4-3

 HOST LOAD FAIL 3-24, 4-6

 HOST NOT CONNECTED
 3-32

 ILLEGAL DIGIT 3-27

 INTERNAL MODEM
 CHECKSUM FAIL 4-2

 INTERNAL MODEM
 LOOPBACK FAIL 4-2

 INTERNAL MODEM REV X.X
 4-3

 INTERNAL MODEM UART
 FAIL 4-2

 INVERSE 2-1-11

 KBD CLOCK FAIL 4-2

 KEYBOARD FAIL 4-2

 KEYBOARD TEST 2-1-12

 NO ANSWER 3-27

 NO DIAL TONE 3-27

 NO REPLY 3-23

 NVM ALTERED 4-8

 PARALLEL PORT FAIL 4-9

 PORT A FAIL 4-10

 PORT B FAIL 4-10

 RAM FAIL 4-2

 RES REV X.X 4-3

 ROM FAIL 4-2

 SELECT FILE NO. 3-27

 SELECT LOAD SOURCE >
 DISK HOST ROM 3-27

 SERIAL PORT TEST SWITCH

- ENABLED 4-11
- TERMINAL READY 3-23
- TEST SWITCH ENABLED 4-2
- TIMER FAIL 4-2
- To run external loopback-enable test switches 2-1-12
- TOUCHPANEL ENABLED 2-1-12
- UNDERScore 2-1-11
- Mode 6 3-21
- Mode installation parameter record 2-4-26
- Mode installation parameters 2-4-12, A
- Mode selection display 3-21, 3-44
- Modem
 - External
 - Installation 2-3-7
 - Operation 3-32
 - Parameters 2-4-23
 - Internal
 - Checkout 2-2-13
 - Connection 2-3-3
 - Installation 2-2-3
 - Operation 3-25
 - Parameters 2-4-17
- Multi-Tech MT212A 2-3-7, 3-32

N

- Non-volatile memory (NVM) 2-4-3
- Norwegian (keyboard) 3-17
- Notches (bezel) 2-1-11
- Numeric pad 3-20

O

- Operating mode 3-2, 3-21
- Operating program 3-2
- Operation test 2-1-10

P

- PACK 2-4-12
- Packing
 - Interface boards 5-7
 - Keyboard 5-6
 - Terminal 5-3

- Panel 3-12
- Parallel printer 2-4-24
- Parallel graphics printer 2-4-6
- Parallel-interface
 - Board 2-2-31
 - Connector 3-14
- Parameter record
 - Terminal installation 2-4-15
 - Mode installation 2-4-26
- Parameters 2-4-2
- Parity 2-4-25
- Pauses (dialing) 2-4-22
- PHONE (utility) 2-4-22, 3-23
- Planning checklist 1-8
- PLATO 2-4-27
- Port A 2-3-17
- Port B 2-3-17
- Power connector 3-14
- Power conversion kit 2-1-4
- Power cord 1-6
- Power line 1-6
- Power-on 3-3
- Power outlet 1-6
- Primary flexible-disk drive 3-38
- Printed-circuit boards 3-3, 5-2, 5-7
- Printer status signals 2-4-25
- Printer 2-4-24
- Problem report form 5-8
- Protected screen positions 3-53
- Protection mode 3-53
- Pulse (dialing) 2-4-9

R

- Racal-Vadic VA3451 2-3-7, 3-32
- Realignment B-1
- Red lights 2-1-12
- Remote (computer) 3-23
- Ringer equivalence number 2-3-3
- RJ11C connector 2-2-10
- RJ11C phone jack 2-3-3
- ROM 3-42
- RS-232-C cable 2-3-7, 2-3-16

S

- Self Test
 - Modem 2-4-8
 - Terminal 3-2

- Serial number 2-2-45
- Serial printer 2-4-11, 2-4-25
- Serial graphics printer 2-4-7, 2-4-11
- Serial-interface
 - Board 2-2-35
 - Connector 2-3-17, 3-14
- Series Code 2-2-12
- Service Center 4-1, 5-1
- Sign-on information 3-34, 3-36
- Sign-on screen 3-34
- "Soft" light bulbs 1-5
- "Soft" light covers 1-5
- Solvents 3-67
- Spanish (keyboard) 3-17
- Special characters 3-61
- Standard (keyboard) 3-15
- Static electricity 1-2
- Supplies 1-7
- Swedish (keyboard) 3-16
- Switches
 - LINE VOLTAGE 2-1-4, 3-11
 - POWER 3-11
 - RESET (primary flexible-disk drive) 3-38
 - RESET (terminal) 3-5, 3-11
 - TEST 2-1-16, 3-11
 - TEST/NORMAL 3-11
- Switches, internal (printer) 2-4-24
- Symbols 3-61

T

- T-adaptor 2-3-4
- Tab Stop 3-58
- Table 1-3
- Telephone company 2-3-3, 2-3-7
- Telephone cord 2-3-4
- Telephone jack 2-3-3
- Telephone line 2-4-9
- Telephone number 3-23
- Telephone-line extension cord 2-3-3
- Temperature 1-2
- Terminal installation parameter record 2-4-12
- Terminal installation parameters 2-4-3, A
- Terminal test 2-1-10

- TERMSET 2-4-3
- Tone (dialing) 2-4-9
- Touchpanel 3-7
- Touchpanel Realignment B-1
- Touchpanel test 2-1-16
- Touch-Tone 2-3-10, 2-4-10
- Typematic (keys) 3-18
- Typing height 1-3

U

- United Kingdom (keyboard) 3-17
- Universal Data Systems (USD) 212 LD 2-3-7, 3-32
- Unpacking 2-1-1
- Uppercase 3-20
- User-assigned mode 2-4-12

V

- Voltage 1-9

W

- Wall jack 2-3-5
- Warranty 1-2
- Weight 1-9
- White tab 2-2-11

X

- XA358-A 2-2-45
- XA360-A 2-2-3
- XA368-A 2-2-19

Y

- YA255 (YA255-A) 2-3-7
- YA274-A 2-2-46
- YA274-B 2-2-46
- YA274-C 2-2-46
- YA274-D 2-2-46
- YA274-E 2-2-46
- YA274-F 2-2-46
- YA275-A 2-1-4
- YR101-A 2-2-35
- YR102-A 2-2-31
- YR104-A 2-2-39