

49763000



---

**STREAMING TAPE UNIT  
92185 - VERTICAL MOUNT**

THEORY OF OPERATION  
DIAGRAMS  
MAINTENANCE  
PARTS IDENTIFICATION

---

**HARDWARE MAINTENANCE MANUAL**

## REVISION RECORD

REVISION	DESCRIPTION
01	Preliminary Release.
A (08-01-84)	Released.
B (11-30-84) Series Code 08	This revision incorporates ECO's 51387, 51316, 51379, 51380, 51411, 51489, 51516, 51476, 51540, and 51520 affecting pages: 5-1/5-2, 5-3 thru 5-11, 5-28, 5-29, 5-32, 5-34 thru 5-36, 5-38 thru 5-44, 5-46 thru 5-64, 5-66 thru 5-84, 5-87 thru 5-93, 5-95 thru 5-118. This revision also incorporates technical changes to pages: vi, 4-2, 4-44, 6-7, 6-25, 6-27, 6-28, 6-30 thru 6-35, 6-37, 6-39, 6-42, 6-43, 6-45, 6-49, 6-51, 6-53 thru 6-61, 6-63 thru 6-65, 6-67, 6-69, 6-70, 6-72, 6-74, 6-76, 6-79, 6-81 thru 6-85, 6-87 thru 6-95, 6-97 thru 6-102, 6-115/6-116, 6-120, 6-168, 6-213, 6-214, and 6-237.
C (01-18-85) (02-22-85) Series Code 09, 10	This revision incorporates ECO's 51419C, 51520 and 51578 affecting page 7-19. This revision includes technical changes affecting pages: 5-75, 6-41, 6-42, 6-106, 6-140, 6-175, 6-203 and 6-237. ECO 51533A is N/A.
D (03-30-85) Series Code 11	This revision incorporates technical and editorial changes affecting pages: ii, iii/iv, v, vi, vii, viii, ix, x, xi, xii, 4-5, 4-8 thru 4-11, 4-15, 4-18, 4-19, 4-20, 5-1/5-2, 6-69, 6-70, and 6-226. ECO 51615 has no effect on this manual.
E (05-20-85) Series Code 12	This revision incorporates ECO 51664 and other technical and editorial changes affecting pages: 6-4 thru 6-14, 6-25 thru 6-117, 6-123 thru 6-127, 6-129 thru 6-148, 6-150, 6-152 thru 6-170, 6-172 thru 6-178, 6-180, 6-181, 6-183 thru 6-183B, 6-185 thru 6-188.
PUB. NO. 49763000	Revision letters I, O, Q, and X are not used.

1984, 1985  
By Control Data Corporation  
Printed in the United States  
of America

Address comments concerning this manual to:

Computer Peripherals, Inc.  
Technical Publications Dept.  
2621 Van Buren Avenue  
Norristown, PA 19403

or use the comment sheet in the back of this manual.



## REVISION RECORD

REVISION	DESCRIPTION
<p>E.1 (06-24-85) Series Code 12</p>	<p>This revision incorporates ECO 51700 and other technical and editorial changes affecting pages: vii, viii, 6-25, 6-27, 6-28, 6-30 thru 6-37, 6-39, 6-41 thru 6-49, 6-51, 6-53 thru 6-61, 6-63 thru 6-65, 6-67, 6-69, 6-70, 6-72, 6-74, 6-76, 6-79, 6-81 thru 6-85, 6-87, 6-89, 6-91 thru 6-95, 6-97 thru 6-102, 6-115/116, 6-120, 6-121, 6-152, 6-167, 6-182, 6-183, 6-183C thru 6-183H, 6-203, 6-236, 6-237, 6-237A, 6-239.</p>
<p>F (08-19-85) Series Code 13</p>	<p>This revision incorporates ECO 51629 and other technical and editorial changes affecting pages: 6-6A, 6-9, 6-10B, 6-47, 6-48, 6-52, 6-57, 6-58, 6-60 thru 6-63, 6-69 thru 6-71, 6-74, 6-76, 6-81, 6-92, 6-95, 6-96, 6-100, 6-152, 6-167, 6-168, 6-183, 6-183B thru 6-188B, 6-222, 6-226, 6-230.</p>
<p>F.1 (09-06-85) Series Code 13</p>	<p>This revision incorporates technical and editorial changes affecting pages: 7-3 thru 7-23.</p>
<p>F.2 (09-27-85) Series Code 13</p>	<p>This revision incorporates technical changes affecting pages: xi, 4-19, 4-31, 6-39, 6-42, 6-43, 6-45, 6-53, 6-63, 6-67, 6-70, 6-76, 6-79, 6-81, 6-82, 6-84, 6-85, 6-89B, 6-92, 6-95, 6-183C thru 6-183J, 6-185, 6-185B, 7-5, 7-11, 7-12, 7-13, 7-22, 7-23, 7-24.</p>
<p>G (10-15-85) Series Code 14</p>	<p>This revision incorporates technical changes affecting pages: 6-152, 6-177, 6-203, 6-215. ECO's 51629, 51751, 51776 have no effect on this manual.</p>
<p>G.1 (11-19-85) Series Code 14</p>	<p>This revision incorporates ECO 51800 affecting page: 7-13.</p>
<p>PUB. NO. 49763000</p>	<p>Revision letters I, O, Q, and X are not used.</p>

## REVISION RECORD

REVISION	DESCRIPTION
G.2 (12-05-85) Series Code 14	This revision incorporates ECO 51850 affecting pages: 7-13, 7-22.
H (12-16-85) Series Code 15	This revision incorporates technical changes affecting pages: 6-182, 6-211, 6-212, 6-212A/B, 6-219, 6-222, 6-232, 6-233, 6-234, 6-236, 6-237, 7-237A, 6-239, 6-240, 6-242, 6-243, 6-245, 7-4, 7-5, 7-9, 7-11, and editorial changes affecting pages: iii, iv, v, vi, vii, ix, x, xi, xii, xiii, xiv, xv, xvi, 5-1, 5-92 thru 5-208, and 7-23.
J (1-22-86) Series Code 16	This revision incorporates ECO's 51790 and 51570 affecting pages: iiv, vi, 7-13 and 7-22.
K (2-20-86) Series Code 17	This revision incorporates ECO 51786, 51765, 51810, 51835 affecting pages: iib, iii, iv, vi, ix, xiii, xiv, 4-4 thru 4-11, 5-3, 5-7 thru 5-27, 5-30, 5-31, 5-32, 5-34, 5-36, 5-39, 5-40, 5-41, 5-68, 5-69, 5-71, 5-72, 5-73, 5-75, 5-78 thru 5-83, 5-85, 5-86, 5-87, 5-90, 6-168, 6-183C, 6-183I, 6-183J, 6-185, 6-185E, 6-185F, 6-225, 6-226, 6-226A, 6-226B, 6-227, 7-13, and 7-22.
L (3-21-86) Series Code 18	This revision records ECO PB 51862 N/A to this manual.
M (4-25-86) Series Code 18,19	This revision incorporates technical and editorial changes affecting pages: iii, v, vi, 4-5, 4-25, 4-27, 4-46, 4-52, 6-123, 6-151, 6-183H, 6-183J, 6-212, 6-216, 6-217, 6-223, 6-226, 6-226A, 6-229, 6-245, 7-6, 7-10 thru 7-13, 7-17, 7-18, 7-20, 7-21. ECO's PB 51919 and 51924A N/A to this manual.

---

PUB. NO.  
49763000

---

Revision letters I, O, Q, and X are not used.

REVISION RECORD

REVISION	DESCRIPTION
N (6-20-86) Series Code 20	This revision incorporates ECO PB 51951 and technical and editorial changes affecting pages: xv, xvi, 4-53, 5-100, 6-7, 6-25, 6-110, 6-152, 6-175, 6-183, 6-185D, 6-185F, 7-13, 7-22, and 7-23. ECO PB 51955 N/A to this manual. Added page 6-100A/B.

---

PUB. NO.  
49763000

---

Revision letters I, O, Q, and X are not used.

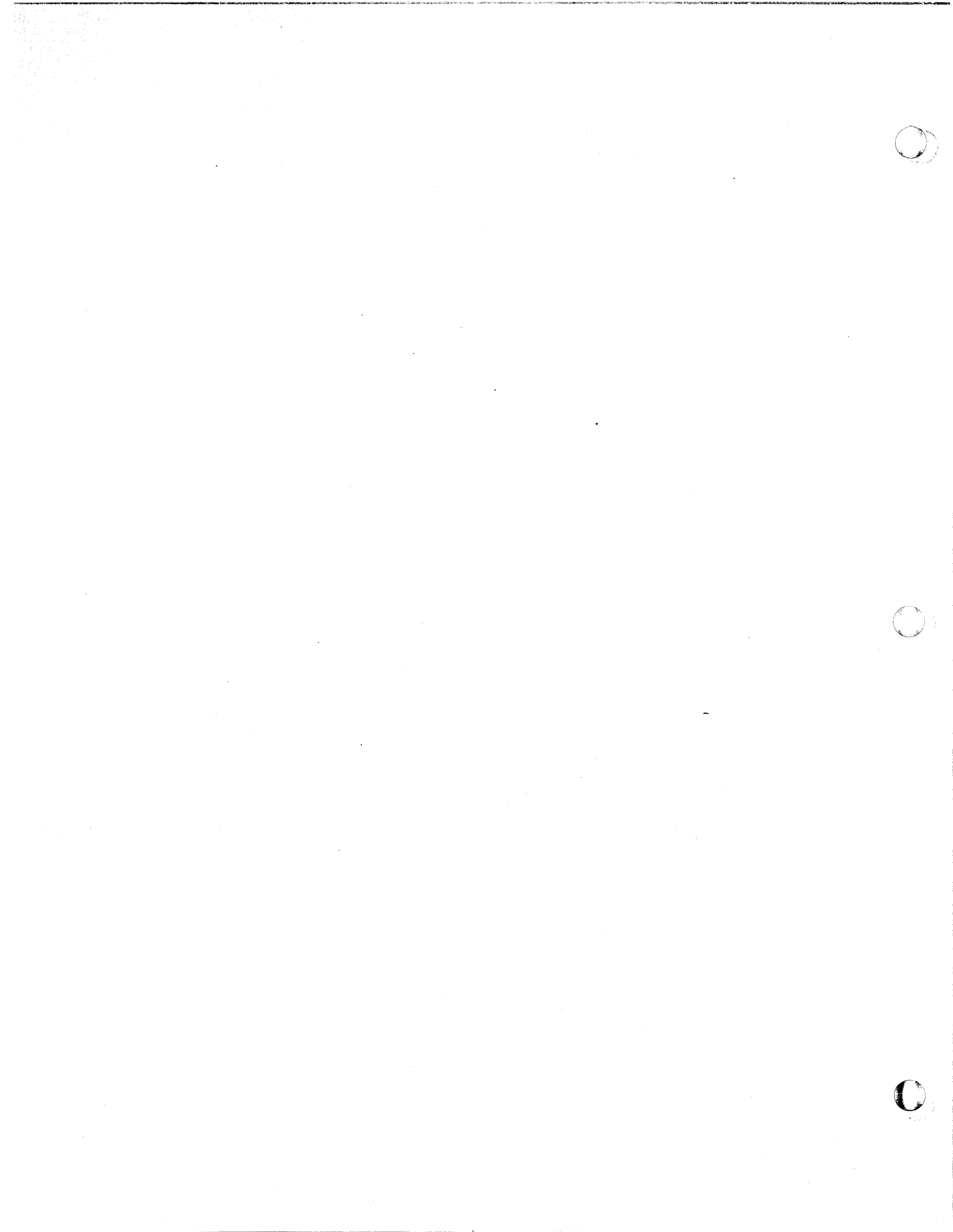

## LIST OF EFFECTIVE PAGES

The revision level of each page is indicated by an alpha character located adjacent to the publication number at the bottom of each page. The revision level of a page will change when the content of the page has been affected by deletions or additions to the page. A bar in the margin indicates where the change has occurred. A dot near the page number indicates the entire page is affected, and a bar adjacent to the page number indicates pagination rather than content has changed.

<u>PAGE</u>	<u>REV</u>	<u>PAGE</u>	<u>REV</u>	<u>PAGE</u>	<u>REV</u>
Cover	-	4-13	-	4-50	-
Warning	-	4-14	-	4-51	-
Title	-	4-15	D	4-52	M
ii	E	4-16	-	4-53	-
ia	G.1	4-17	-	4-54	-
ib	K	4-18	D	4-55	-
iii	K	4-19	F.2	4-56	-
iv	K	4-20	D	4-57	-
v	H	4-21	-	4-58	-
vi	K	4-22	-	4-59	-
vii	H	4-23	-	4-60	-
Blank	-	4-24	-	4-61	-
ix	K	4-25	M	4-62	-
x	H	4-26	-	4-63	-
xi	H	4-27	M	4-64	-
xii	H	4-28	-	4-65	-
xiii	K	4-29	-	4-66	-
xiv	K	4-30	-	4-67	-
xv	H	4-31	F.2	4-68	-
xvi	H	4-32	-	4-69	-
4-1	-	4-33	-	4-70	-
4-2	B	4-34	-	5-1	H
4-3	-	4-35	-	Blank	-
4-4	K	4-36	-	5-3	K
4-5	M	4-37	-	5-4	B
4-6	K	4-38	-	5-5	B
4-7	K	4-39	-	5-6	B
4-8	K	4-40	-	5-7	K
4-8A	K	4-41	-	5-8	K
4-8B	K	4-42	-	5-9	K
4-8C	K	4-43	-	5-10	K
4-8D	K	4-44	B	5-11	K
4-9	K	4-45	-	5-12	K
Blank	-	4-46	M	5-13	K
4-11	K	4-47	-	5-14	K
4-12	-	4-48	-	5-15	K
		4-49	-	5-16	K

PAGE	REV
5-17	K
5-18	K
5-19	K
5-20	K
5-21	K
5-22	K
5-23	K
5-24	K
5-25	K
5-26	K
5-27	K
5-28	B
5-29	B
5-30	K
5-31	K
5-32	K
5-33	-
5-34	K
5-35	B
5-36	K
5-37	-
5-38	B
5-39	K
5-40	K
5-41	K
5-42	B
5-43	B
5-44	B
5-45	-
5-46	B
5-47	B
5-48	B
5-49	B
5-50	B
5-51	B
5-52	B
5-53	B
5-54	B
5-55	B
5-56	B
5-57	B
5-58	B
5-59	B
5-60	B
5-61	B

PAGE	REV
5-62	B
5-63	B
5-64	B
5-65	-
5-66	B
5-67	B
5-68	K
5-69	K
5-70	B
5-71	K
5-72	K
5-73	K
5-74	B
5-75	K
5-76	B
5-77	B
5-78	K
5-79	K
5-80	K
5-81	K
5-82	K
5-83	K
5-84	B
5-85	K
5-86	K
5-87	K
5-88	B
5-89	B
5-90	K
5-91	B
5-92	H
5-93	H
5-94	H
5-95	H
5-96	H
5-97	H
5-98	H
5-99	H
5-100	H
5-101	H
5-102	H
5-103	H
5-104	H
5-105	H
5-106	H

PAGE	REV
5-107	H
5-108	H
6-1	-
6-2	-
6-3	-
6-4	E
6-5	E
6-6	E
6-6A	F
6-6B	E.1
6-7	E
6-7A	E
Blank	-
6-8	E
6-9	F
6-9A	E
Blank	-
6-10	E
6-10A	E
6-10B	F
6-11	E
6-12	E
6-13	E
6-14	E
6-15	-
6-16	-
6-17	-
6-18	-
6-19	-
6-20	-
6-21	-
6-22	-
6-23	-
6-24	-
6-25	E.1
6-26	E
6-27	E.1
6-28	E.1
6-29	E
6-30	E.1
6-31	E.1
6-32	E.1
6-33	E.1
6-34	E.1

PAGE	REV
6-35	E.1
6-36	E
6-37	E.1
6-38	E
6-39	F.2
6-40	E
6-41	E.1
6-42	F.2
6-43	F.2
6-44	E.1
6-45	F.2
6-46	E.1
6-47	F
6-48	F
6-49	E.1
6-50	E
6-51	E.1
6-52	F
6-53	F.2
6-54	E.1
6-55	E.1
6-56	E.1
6-51	F
6-58	F
6-59	E.1
6-60	F
6-61	F
6-62	F
6-63	F.2
6-64	E.1
6-65	E.1
6-66	E
6-67	F.2
6-68	E
6-69	F
6-70	F.2
6-71	F
6-72	E.1
6-73	-
6-74	F
6-75	E
6-76	F.2
6-77	E
6-78	E
6-79	F.2

PAGE	REV
6-80	E
6-81	F.1
6-82	F.2
6-83	E.1
6-84	F.2
6-85	F.2
6-86	E
6-87	E.1
6-88	E
6-89	E.1
6-89A	E.1
6-89B	F.2
6-90	-
6-91	E.1
6-92	F.2
6-93	E.1
6-94	E.1
6-95	F.2
6-96	F
6-97	E.1
6-98	E.1
6-99	E.1
6-100	F
6-101	E.1
6-102	E.1
6-103	E
6-104	E
6-105	E
6-106	E
6-107	E
6-108	E
6-109	E
6-110	E
6-111	E
6-112	E
6-113	E
6-114	E
6-115	E.1
Blank	-
6-117	E
6-118	-
6-119	E.1
6-120	E.1
6-121	E.1
6-122	E.1

PAGE	REV
6-123	M
6-124	E
6-125	E
6-126	E
6-127	E
6-128	-
6-129	E
6-129A	E.1
6-129B	E.1
6-130	E
6-131	E
6-132	E
6-133	E
6-134	E
6-135	E
6-136	E
6-137	E
6-138	E
6-139	E
6-140	E
6-141	E
6-142	E
6-143	E
6-144	E
6-145	E
6-146	E
6-147	E
6-148	E
6-149	E
6-150	E
6-151	M
6-152	G
6-153	E
6-154	E
6-155	E
6-156	E.1
6-156	E.1
Blank	-
6-157	E
6-158	E
6-159	E
6-160	E
6-161	E
6-162	E
6-163	E

<u>PAGE</u>	<u>REV</u>
6-164	E
6-165	E
6-166	E
6-167	F
6-168	K
6-169	E
6-170	E
6-171	-
6-172	E
6-173	E
6-174	E
6-175	E
6-176	E
6-177	G
6-178	E
6-179	-
6-180	E
6-181	E
6-182	H
6-183	H
6-183A	E
6-183B	F
6-183C	K
6-183D	F.2
6-183E	F.2
6-183F	F.2
6-183G	F.2
6-183H	M
6-183I	K
6-183J	M
6-184	F
6-185	K
6-185A	F
6-185B	F.2
6-185C	F
6-185D	F
6-185E	K
6-185F	K
6-186	F
6-187	F
6-188	F
6-188A	F
6-188B	F
6-189	-
6-190	-

<u>PAGE</u>	<u>REV</u>
6-191	-
6-192	-
6-193	-
6-194	-
6-195	-
6-196	-
6-197	-
6-198	-
6-199	-
6-200	-
6-201	-
6-202	-
6-203	G
6-203A	G
6-203B	G
6-204	-
6-205	-
6-206	-
6-207	-
6-208	-
6-209	-
6-210	-
6-211	H
6-212	M
6-212A/B	H
Blank	-
6-213	-
6-214	B
6-215	G
6-216	M
6-217	M
6-218	-
6-219	H
6-220	-
6-221	-
6-222	H
6-223	M
6-224	-
6-225	K
6-226	M
6-226A	M
6-226B	K
6-227	-
6-228	-
6-229	M
6-230	F
6-231	-

<u>PAGE</u>	<u>REV</u>
6-232	H
6-233	H
6-234	H
6-235	-
6-236	H
6-237	H
Blank	-
6-237A	H
6-238	-
6-239	H
6-240	H
6-241	-
6-242	H
6-243	H
6-244	-
6-245	M
6-246	-
6-247	-
6-248	-
7-1	-
7-2	-
7-3	F.1
7-4	H
7-5	H
7-6	M
7-7	F.1
7-8	F.1
7-9	H
7-10	M
7-11	M
7-12	M
7-13	M
7-14	F.1
7-15	F.1
7-16	F.1
7-17	M
7-18	M
7-19	F.1
7-20	M
7-21	M
7-22	K
7-23	H
Blank	-
Comment	-
Mailer	-



## PREFACE

The purpose of this manual is to furnish to the customer engineer information needed to maintain the 92185 STU. It is assumed that the customer engineer has had training and/or experience on the 92185 or similar tape units. Under no circumstances should maintenance be attempted by any one without the prerequisite skills and experience.

Hardware reference/maintenance information is separated into two publications on a task-oriented basis. This manual, publication number 49763000, presents technical maintenance information in the following sections:

- 4 - THEORY OF OPERATION
- 5 - DIAGRAMS
- 6 - MAINTENANCE
- 7 - PARTS IDENTIFICATION

The other manual, publication number 49762900, presents routine operation, maintenance, and installation instructions in the following sections:

- 1 - GENERAL INFORMATION
- 2 - OPERATION
- 3 - INSTALLATION AND CHECKOUT

The manuals identified above are available through the nearest Control Data Sales Office.

### WARNING

This equipment generates, uses, and can radiate radio frequency energy, and if not installed and used in accordance with the instructions manual, may cause interference to radio communications. It has been tested and found to comply with the limits for a Class A peripheral computing device pursuant to Subpart J of Part 15 of the FCC Rules, which are designed to provide reasonable protection against such interference when operated in a commercial environment. Operation of this equipment in a residential area is likely to cause interference, in which case, the user, at his own expense, will be required to take whatever measures may be required to correct the interference.



## TABLE OF CONTENTS

	<u>PAGE</u>
Section 4 - THEORY OF OPERATION	
<u>GENERAL INFORMATION</u>	4-1
<u>PHYSICAL DESCRIPTION</u>	4-1
POWER SUPPLY	4-3
TENSION/SPEED CONTROL	4-3
MAGNETIC HEAD	4-4
LOGIC AND CONTROL CIRCUITS	4-4
Formatter/Interface Logic Set	4-5
Read/Write/Servo Logic Set	4-5
<u>POWER SUPPLY</u>	4-5
GENERAL DESCRIPTION	4-5
PHYSICAL DESCRIPTION	4-5
Voltage Select PWA (7701896X Series Power Supplies)	4-8
Voltage Select Plug (7702934X Series Power Supplies)	4-8
Power Supply Control PWA	4-8
Main Power Supply PWA	4-8
POWER SUPPLY FUNCTIONAL DESCRIPTION	4-8A
Input Power Selection	4-8A
Standby Voltage Generation	4-11
Power-On Sequence	4-13
Switching Converter	4-15
DC Voltages	4-17
Low-Voltage/Over-Voltage Detection	4-17
<u>PNEUMATIC SYSTEM</u>	4-18
OPERATIONAL DESCRIPTION	4-19
<u>SERVO-CONTROL PWA FUNCTIONAL DESCRIPTION</u>	4-21
GENERAL INFORMATION	4-21
Formatter Commands/Response	4-21
Transport Control/Monitoring	4-21
Control Panel Command Execution	4-21
Tape Motion/Servo Control	4-21
SERVO-CONTROL MICROPROCESSOR	4-22
VELOCITY SERVO	4-24
TENSION SERVO	4-25

## TABLE OF CONTENTS

	<u>PAGE</u>
Section 4 (Cont'd)	
<u>POWER DRIVER PWA</u>	4-27
<u>WRITE DRIVER PWA</u>	4-32
WRITE CONTROL	4-32
WRITE DRIVER LSI	4-34
DEGAUSSING	4-35
<u>READ AMPLIFIER PWA</u>	4-36
READ RECOVERY	4-36
Automatic Gain Control	4-38
LOOP DATA	4-39
<u>FORMATTER PWA</u>	4-40
I/O COMMAND TRANSLATION	4-40
DATA CONVERSION	4-42
PE Data Conversion	4-42
GCR Data Conversion	4-42
TAPE CONTROL AND IDENTIFIER MARK GENERATION AND DELETION	4-42
PE Data Block Format	4-45
GCR Data Block Format	4-45
ERROR DETECTION AND CORRECTION	4-52
<u>INTERFACE PWA</u>	
<u>SYSTEM AND TIMING CONSIDERATING</u>	4-55
MOTION CHARACTERISTICS	4-55
START/STOP MODE	4-55
Read Operations	4-56
Write Operations	4-56
Other Start/Stop Characteristics	4-56
STREAMING MODES	4-56
25 IPS MODE CONTROL	4-70
ADAPTIVE VELOCITY CONTROL	4-70

## TABLE OF CONTENTS

	<u>PAGE</u>
Section 5 - DIAGRAMS	
<u>GENERAL</u>	5-1
Section 6 - MAINTENANCE	
<u>GENERAL DESCRIPTION</u>	6-1
TROUBLE ANALYSIS	6-1
REMOVAL/REPLACEMENT PROCEDURES	6-2
- TROUBLE ANALYSIS	6-3
<u>GENERAL INFORMATION</u>	6-3
<u>CUSTOMER ENGINEER PROCEDURES</u>	6-4
PRE-SITE PROCEDURES	6-4
Corrective Action Matrices	6-4
ON-SITE PROCEDURES	6-14
<u>Diagnostic Tests</u>	6-14
Operator Diagnostics	6-14
Diagnostic Test Procedures	6-16
Customer Engineer Diagnostics	6-18
Customer Engineer Special Load/Unload Procedures	6-20
Sub-Fault Codes	6-20
<u>STRUCTURED ANALYSIS METHOD (SAM) TABLES</u>	6-21
SUB-FAULT CODE INTERPRETATION	6-22
TROUBLESHOOTING DIAGRAMS	6-23
- TEST DESCRIPTIONS	6-117
<u>GENERAL INFORMATION</u>	6-117
INITIATING A DIAGNOSTIC TEST AND SELECTING OPTIONS	6-118
LIST OF DIAGNOSTIC TESTS	6-119

## TABLE OF CONTENTS

	<u>PAGE</u>
Section 6 (Cont'd)	
- REMOVAL/REPLACEMENT (R/R) PROCEDURES	6-189
<u>MAINTENANCE POSITION (ACCESS TO REAR COMPONENTS)</u>	6-193
FRONT COVER INTERLOCK SWITCH	6-193
DRIVE COVER R/R	6-195
TAPE CLEANER R/R	6-196
DOOR INTERLOCK SWITCH R/R	6-198
FILE PROTECT SENSOR R/R	6-199
EOT/BOT SENSOR R/R	6-200
TAKE-UP REEL HUB R/R	6-202
TAKE-UP REEL MOTOR R/R	6-203
SUPPLY REEL HUB R/R	6-204
SUPPLY REEL MOTOR R/R	6-206
SUPPLY REEL MOTOR TACH AND SENSOR R/R	6-210
AIR BEARING SENSOR R/R	6-211
AIR BEARING SPRING GUIDE R/R	6-213
COMPRESSOR R/R	6-215
PRESSURE REGULATOR AND FILTER R/R	6-217
MAGNETIC HEAD R/R	6-219
OPERATOR PANEL R/R	6-223
COOLING FAN R/R	6-224
POWER SUPPLY R/R	6-225
CAPACITOR R/R	6-228
WRITE DRIVER R/R	6-230
READ AMPLIFIER R/R	6-232
SERVO-CONTROL R/R	6-236
FORMATTER READ R/R	6-239
FORMATTER WRITE R/R	6-242
INTERFACE R/R	6-245
POWER DRIVER R/R	6-247

## Section 7 - PARTS IDENTIFICATION

<u>PARTS DATA</u>	7-1
-------------------	-----

## LIST OF FIGURES

<u>NO.</u>	<u>TITLE</u>	<u>PAGE</u>
4-1	STU Functional Block Diagram	4-2
4-2	Major Power Supply Components	4-6
4-3	Power Supply Block Diagram	4-7
4-4A	Voltage Select PWA (7701896X Series Power Supplies)	4-8C
4-4B	Voltage Select Plug (7702934X Series Power Supplies)	4-8D
4-5A	Cooling Fan Wiring (7701896X Series Power Supplies)	4-9
4-5B	Cooling Fan Wiring (7702934X Series Power Supplies)	4-11
4-6	Stand-By Voltage Generation	4-12
4-7	Power-On Sequence Flowchart	4-14
4-8	High Voltage Generation	4-15
4-9	Switching Converter Circuit	4-16
4-10	Vacuum and Pressure Distribution	4-19
4-11A	Compressor Wiring 120V ac	4-20
4-11B	Compressor Wiring 220V ac	4-20
4-12	Servo-Control Block Diagram	4-23
4-13	Velocity Servo - Simplified	4-24
4-14	Tension Servo - Simplified	4-26
4-15	Power Driver Block Diagram	4-28
4-16	Power Driver Waveforms	4-29
4-17	H-Bridge Switching	4-30
4-18	Switched +5 Volts	4-31
4-19	Write Control Block Diagram	4-33
4-20	Write Driver Block Diagram	4-34
4-21	Degaussing Waveform	4-35
4-22	Read Amplifier Block Diagram	4-37
4-23	I/O Command Translation	4-41
4-24	Phase Encoding	4-43
4-25	GCR Conversion	4-44
4-26	GCR Translation Values	4-44
4-27	NRZI Encoding	4-45
4-28	PE Format	4-46
4-29	GCR Tape Format	4-47
4-30A	Detail of GCR Tape Format	4-49
4-30B	Detail of GCR Tape Format	4-49
4-30C	Detail of GCR Tape Format	4-50
4-30D	Detail of GCR Tape Format	4-51
4-31	Phase Error Window - PE Mode	4-53
4-32	Phase Error Window - GCR Mode	4-54
4-33	Streaming Mode Velocity Diagram	4-63
4-34	Case 1 - Tape Motion Control	4-65
4-35	Case 2 - Velocity Profile	4-66
4-36	Case 2 - Tape Motion Control	4-67
4-37	Case 3 - Velocity Profile	4-68
4-38	Case 3 - Tape Motion Control	4-69

## LIST OF FIGURES (Cont'd)

<u>NO.</u>	<u>TITLE</u>	<u>PAGE</u>
6-1	Flowchart of On-Site Trouble Analysis	6-15
6-2	Example of Structured Analysis Method (SAM)	6-21
6-3	Sub-Fault Code Interpretation (Example 1)	6-22
6-4	Sub-Fault Code Interpretation (Example 2)	6-23
6-5	Test 54 Hex Symbols	6-172
6-6A	STU Component Location	6-190
6-6B	STU Component Location	6-191
6-6C	STU Component Location	6-192
6-7	Access To Rear Tape Deck Components	6-194
6-8	Drive Cover Removal	6-195
6-9	Tape Cleaner	6-196
6-10	Door Interlock Switch (Rear View)	6-198
6-11	File Protect Sensor Alignment	6-199
6-12	EOT/BOT Sensor	6-200
6-13	Take-Up Reel	6-202
6-14	Supply Reel Hub Assembly	6-204
6-15	Supply Reel Assembly	6-206
6-16	Take-Up Reel Motor Disassembly	6-207
6-17	Tach/Sensor Assembly/Adjustment	6-210
6-18	Air Bearing Transducers	6-211
6-19	Air Bearing Spring Guide	6-213
6-20	Compressor	6-215
6-21	Regulator and Filter Removal	6-218
6-22	Magnetic Head Assembly	6-219
6-23	Magnetic Head Connectors	6-221
6-24	Servo-Control PWA	6-221
6-25	Operator Panel Assembly	6-223
6-26	Cooling Fan and Power Supply	6-224
6-27A	Voltage Select PWA (7701896X Series Power Supplies)	6-225
6-27B	Voltage Select PWA (7701896X Series Power Supplies)	6-225
6-28	Power Terminal Strip TB-1	6-227
6-29	Capacitor	6-228
6-30	Write Driver PWA Connectors	6-231
6-31	Write Driver/Read Amp/Servo-Control PWAs	6-234
6-32	Read Amplifier PWA Connectors	6-235
6-33	Servo-Control PWA Connectors	6-238
6-34	Formatter Read/Write/Interface PWAs	6-240
6-35	Formatter Read PWA Connectors	6-241
6-36	Formatter Write PWA Connectors	6-244
6-37	Interface PWA Connectors	6-246
6-38	Power Driver Connectors	6-248



LIST OF FIGURES (Cont'd)

<u>NO.</u>	<u>TITLE</u>	<u>PAGE</u>
7-1	Door Assembly - Vertical	7-4
7-2	Equipment Assembly - Front	7-6
7-3	Equipment Assembly - Rear	7-8
7-4	Equipment Assembly - Rear	7-10
7-5	Equipment Assembly - Rear	7-12
7-6	Motor Assembly, Take-Up Reel	7-14
7-7	Motor Assembly, Supply Reel	7-16
7-8	Air Bearing Assembly - Upper	7-18
7-9	Air Bearing Assembly - Lower	7-20

## LIST OF TABLES

<u>NO.</u>	<u>TITLE</u>	<u>PAGE</u>
4-1	STU Operational Performance Summary	4-58
4-2	Streaming Mode Motion Sequence Chart	4-64
5-1	Schematic Index	5-1
6-1	Referenced Maintenance Aids	6-2
6-2	Malfunction/Assembly Failure Matrix	6-5
6-3	Fault Code Matrix (Operator Test 01)	6-6
6-4	Test 02 Termination Codes Following Test 01 Fault Code 22	6-8
6-5	Test 02 Termination Codes Following Test 01 Fault Code 24	6-8
6-6	Test 02 Termination Codes Following Test 01 Fault Code 26	6-9
6-7	Test 02 Termination Codes Following Test 01 Fault Codes 30, 31, or 36	6-9
6-8	Test 03 Termination Codes Following Test 01 Fault Code 03	6-10
6-9	Test 03 Termination Codes Following Test 01 Fault Code 25	6-10
6-10	Test 03 Termination Codes Following Test 01 Fault Codes 04, 06, or 36	6-11
6-11	Test 03 Termination Codes Following Test 01 Fault Code 32	6-11
6-12	Test 03 Termination Codes Following Test 01 Fault Code 33 or 35	6-12
6-13	Test 03 Termination Codes Following Test 01 Fault Code 48	6-12
6-14	Test 03 Termination Codes Following Test 01 Fault Code 52	6-13
6-15	Test 03 Termination Codes Following Test 01 Fault Code 30 or 31	6-13
6-16	Removal/Replacement Index	6-189
7-1	Printed Wiring Assemblies	7-22
7-2	Cable Assemblies	7-23

---

## GENERAL INFORMATION

In this section of the manual, the principles of operation of the streaming tape unit (STU) are discussed. Descriptions are provided for the functions of the transport on a major component basis. Major areas of discussion are as follows:

- o Power Supply
- o Pneumatic System
- o Servo/Control PWA
- o Power Driver PWA
- o Write Driver PWA
- o Read Amplifier PWA
- o Formatter PWAs
- o Interface PWA
- o System and Timing Considerations

Text is supported by diagrams, flowcharts and timing charts, where required, to facilitate understanding of the description. Diagrams contained in this section are condensed and simplified, and in no way should be used for transport troubleshooting. Logic diagrams and schematics contained in section 5 take precedence over any diagrams contained in the theory of operation. Refer to figure 4-1 for a block diagram of the STU.

A brief functional description of major functional areas of the STU is given in succeeding paragraphs. A more detailed circuit description then follows with accompanying block diagrams and flowcharts.

## PHYSICAL DESCRIPTION

The STU is a dual-speed reel-to-reel tape drive unit not requiring conventional capstan drive, tension arms, or vacuum columns. Tape is transported directly under electronic control, with no tape buffers required. Tension is sensed electronically by tension sensors built directly into the tape path. The major equipment components or subsystems are control, formatter, and interface PWAs, read/write head assembly and circuits, pneumatics/cooling systems, and the power supply and distribution circuitry. The following paragraphs give a brief description of the overall transport functions.

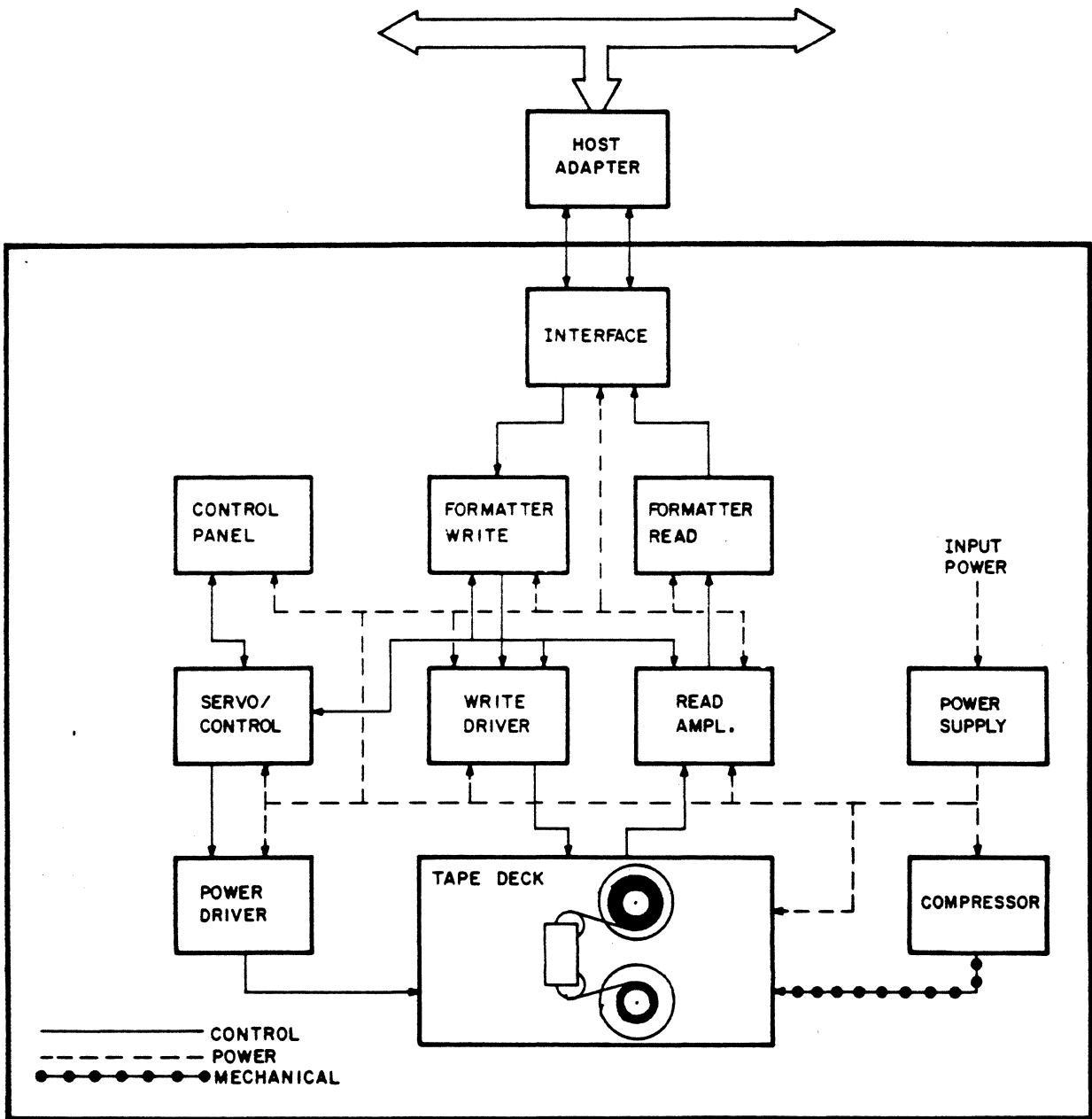

Figure 4-1. STU Functional Block Diagram

## POWER SUPPLY

The power supply is activated when the ON/OFF power switch (main circuit breaker) is in the ON position. This allows the LOGIC ON indicator on the control panel to illuminate, and also supplies the ac power to operate the cooling fan motor.

Pressing the ON/OFF power switch generates all the necessary dc voltages used throughout the STU logic circuits, as well as initiating a MASTER CLEAR pulse. This pulse is used to steer the control logic functions to a starting or known state prior to starting a Load operation.

An auto load feature built into the power supply allows the host system to perform a power-on, automatic load operation of the tape is threaded. At the conclusion of the autoload sequence, an ON-LINE status is indicated.

## TENSION/SPEED CONTROL

The load function is initiated by the LOAD switch on the control panel when off-line. The pneumatic pump is activated at this time, causing air pressure to be gated to the air bearings. Air flow gated through holes in the bearings senses the tension of the tape through sensors physically located on the air bearings. The sensor output signals are applied to a tension servo circuit, whereby the supply (file) reel is directed to drive so that approximately 8 ounces of tension is maintained consistently across the tape path.

Tape speed is maintained through the use of a 1000 line tach and a one-line tach located on the rear of the reel motors. Tach information is applied to an electronically controlled servo, where a calculation is made of the linear velocity (inches per second) and the radius of the take-up reel. The radius of tape on the reel is always a known factor, therefore, linear velocity can be compensated for without the use of a capstan drive circuit.

## MAGNETIC HEAD

The magnetic head fulfills the objective of the STU; ie., to read from or to write to magnetic tape. This assembly consists of a sectionalized read/write head and an erase head. Selection of the read or write modes of operation is made by the host through the control logic circuits. Data is transferred from or to the host via data lines that are gated to the individual read heads by the read/write circuits. Read recovery circuits convert the readback data to a digital format compatible with the control and formatter logic. Write driver circuits convert the logic-compatible write data to current levels required to drive the write head coils.

## LOGIC AND CONTROL CIRCUITS

The electronic components are divided physically into two sets; each set is housed in a separate cage. One cage contains the formatter/interface logic set consisting of the formatter write PWA, formatter read PWA, and interface PWA. The other cage contains the read/write/servo logic set consisting of the read amplifier PWA, write driver PWA, and servo/control PWA.

### Formatter/Interface Logic Set

The interface PWA serves as the transport link to the host. The interface PWA receives commands and data from the host, checks them for validity, and passes them onto the formatter PWAs. Also, the interface PWA manages the flow of data and status codes from the transport to the host during read operations.

The formatter write PWA receives commands and data from the interface PWA, translates the commands for the tape drive, and encodes the data into either PE or GCR format. The formatter write PWA also generates tape control and identification signals, and error checking and correction codes.

The formatter read PWA decodes the data from the PE or GCR format, and studs off the tape control and signal marks. The data is checked for errors and, if detected, the errors are corrected if possible, or the error condition is reported to the interface PWA.

## Read/Write/Servo Logic Set

The read amplifier PWA amplifies the data signals detected by the magnetic head, and converts these analog signals to digital logic levels usable by the formatter and interface logic.

The write driver PWA furnishes up to 140 mA of drive current to the write head with write compensation and ac bias up to 80 mA.

The servo/control PWA receives, validates, and executes commands from the formatter. The servo/control PWA also regulates the tape motion and responds to manually initiated commands from the control panel.

## POWER SUPPLY

### GENERAL DESCRIPTION

The power supply accepts regulated inputs of 120V or 220-240V power, with the only change in configuration being the positioning of the voltage select PWA on (P/N 7701896X) power supplies or positioning of the voltage select plug on (P/N 7702934X) power supplies. A functional description of this change is discussed in succeeding paragraphs. The major function of the power supply is to provide ac power to the cooling fan and pneumatic pump, to generate dc voltages used throughout the transport, and to provide shut-down capabilities in the event of abnormal voltage conditions.

### PHYSICAL DESCRIPTION

Power supply P/N 7701896X components consist of the ac input receptacle, line filter, circuit breaker (mounted on the top front of tape deck), voltage select PWA, main power supply PWA, and power supply control PWA. Power supply P/N 7702934X components are the same as power supply P/N 7701896X except a voltage select plug is used in place of a voltage select PWA. A simplified block diagram of major components is shown in figure 4-2. A brief functional description of the three power supply PWA's is as follows:

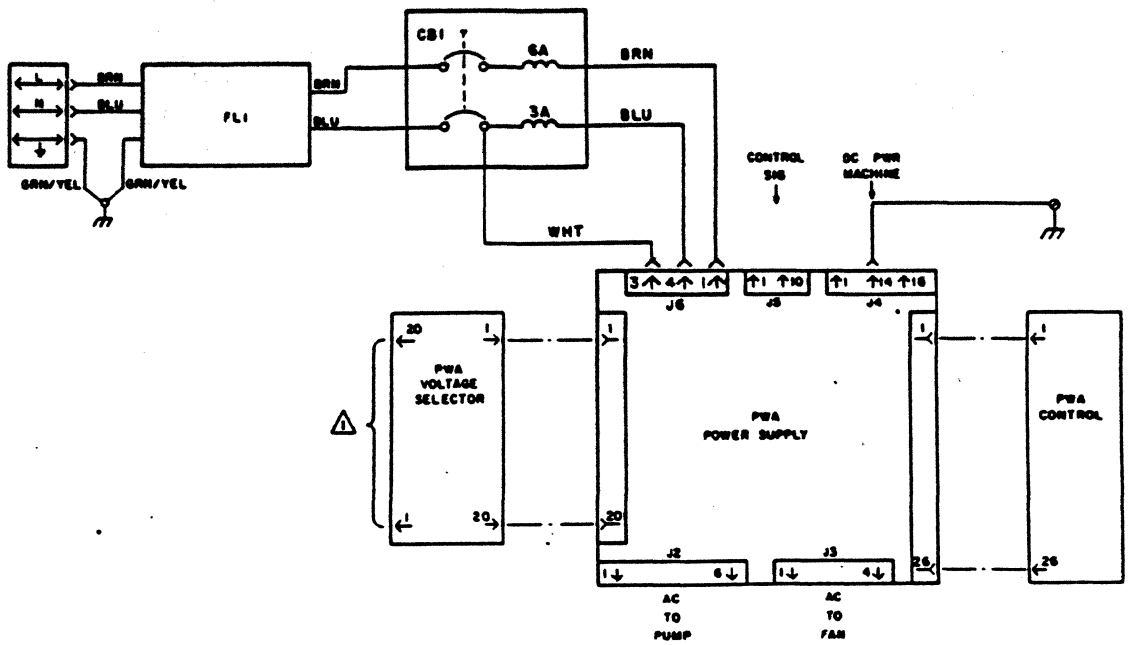

⚠ BOARD FLIPS FOR 120V.60HZ. OR 220V.50HZ

### A. 7701896X Series Power Supply

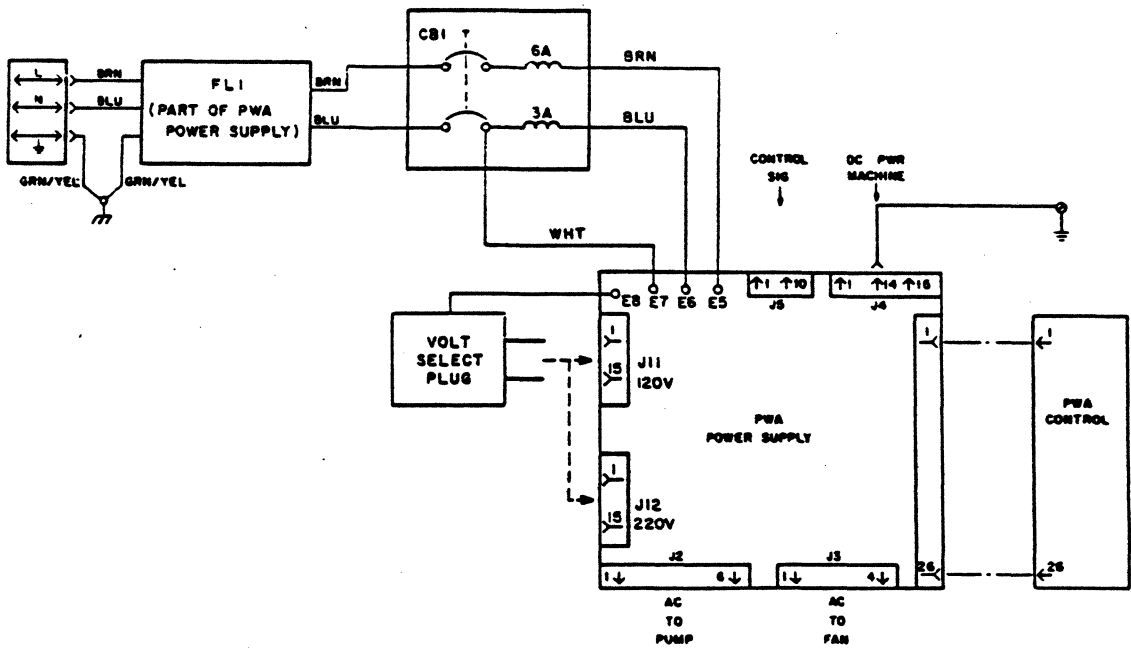

### B. 7702934X Series Power Supply

Figure 4-2. Major Power Supply Components



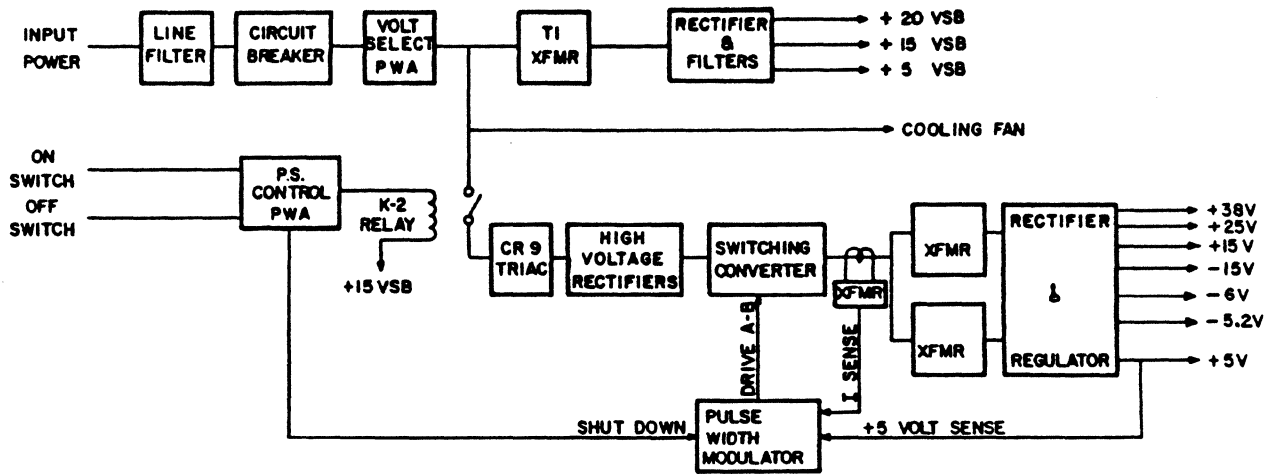

A. 7701896X Series Power Supply

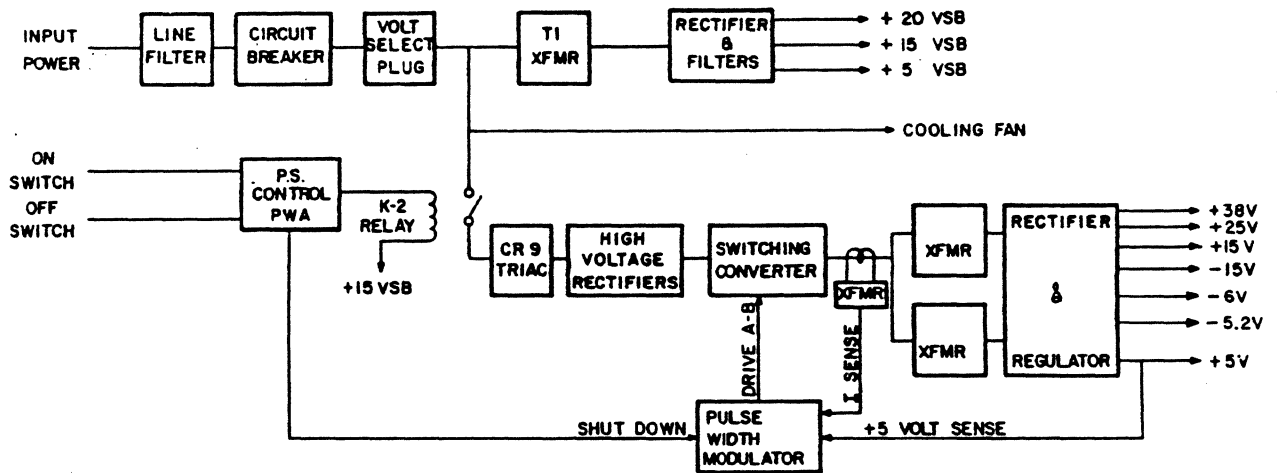

B. 7702934X Series Power Supply

Figure 4-3. Power Supply Block Diagram

### Voltage Select PWA (7701896X Power Supplies)

This PWA consists of two connectors labeled J1A and J1B and three fuses. Two fuses are used in the input ac lines to the standby voltage supply, and the remaining fuse is used for protection of components in the internal high voltage circuit. The land layout of the PWA is such that the input lines from the line filter are matched to the input transformer in a configuration compatible with either 120V or 220-240V. Connector J1A is inserted into the main PWA if 120V is provided; connector J1B is used for the 220-240V requirement. Connector keys are provided on the PWA edge connectors to eliminate the possibility of incorrect insertion. The voltage select PWA is mounted vertically into the main power supply PWA at connector J6.

### Voltage Select Plug (7702934X Power Supplies)

The voltage select plug consists of a 15-pin connector with a cable strain relief mounted on top. The plug is hard-wired to point E8 on the main power supply PWA. When 120V input is provided, the voltage select plug is inserted in the 120V receptacle (J11) on the main power supply PWA. When 220-240V input is provided, the voltage select plug is inserted in the 200V receptacle (J12) on the main power supply PWA.

### Power Supply Control PWA

The power supply control PWA consists of the low voltage and over-voltage detect circuits, automatic power-on circuits, LOGIC ON/LOGIC OFF control panel indicator circuits, master clear circuit, and power-on latching circuit. Like the voltage select PWA, the control PWA is mounted vertically into the main power supply PWA at connector J8.

### Main Power Supply PWA

The main power supply PWA is responsible for generating dc voltages for all functions in the transport. A brief description of the circuits comprising the main power supply PWA is as follows:

#### o Standby Voltage Circuit

Standby voltages of +20, +15 and +5 volts are developed to provide a separate supply voltage for all other control circuits associated with the power supply. The standby voltages are used only within the power supply.

- o Pulse Width Modulator

This circuit monitors the +5 volt logic level and develops a pulse train to drive the half bridge switching converter. The pulse width modulator also provides the means by which abnormal conditions cause the shut-down of the output voltages.

- o Half-Bridge Switching Converter

This circuit contains the pulse width modulator, totem-pole driver circuits, high voltage rectifier, and transformers coupling the converted energy to the regulated dc voltage output circuits.

- o Regulated dc Voltages

The regulated dc voltages generated on the main PWA include +5V, -5.2V, -6V, + 15V, +25V and +38V. The circuits consist of output transformers, full wave rectifiers, filtering networks and regulators.

#### POWER SUPPLY FUNCTIONAL DESCRIPTION

The following discussion of circuit operation is presented in the sequence in which the power supply is activated. Reference should be made to the accompanying block diagrams or to the power supply schematics contained in the Logic Diagrams section of this manual.

#### Input Power Selection

Input power (120V or 220-240V) is applied from the power line cord connected to the power supply receptacle and into a line filter for noise suppression. Power is then supplied to the transport power switch (circuit breaker) located on the tape deck. The switch portion of the circuit breaker is labeled 1 (ON) and 0 (OFF). With the circuit breaker placed in the 1 position, input power is routed through connectors and into the voltage select PWA on 7702896X Series power supplies or the voltage select plug on 7702934X Series power supplies. It is, at this point, that circuit selection is made for either 120V or 220-240 VAC. Refer to figure 4-4 for circuit differences.

### 7701896X Series Power Supplies

If 120V input power is being applied, the voltage select PWA is positioned so that connector J1A is plugged into the main power supply PWA. If an overload condition is present at transformer T1, the F3 and/or F2, 1/8A fuses will blow. The fuses are situated so that any external taps of the primary (i.e., pneumatic pump operation) do not affect the fuses which are used only for detection of an overload condition at transformer T1.

If 220-240V input power is being applied, then the voltage select PWA is positioned so that connector J1B is plugged into the main power supply PWA. With this configuration, the two primaries of transformer T1 are wired in series, with only the F3 fuse applicable to the circuit.

### 7702934X Series Power Supplies

If 120V input power is being applied, the voltage select plug is inserted in the 120V receptacle (J11) on the main power supply PWA. If an overload condition is present at transformer T1, the F1 and/or F2, 1/8A fuses will blow. The fuses are situated so that any external taps of the primary (i.e., pneumatic pump operation) do not affect the fuses, which are used only for detection of an overload condition at transformer T1.

If 220-240V input power is being applied, then the voltage select plug is inserted in the 220V receptacle on the main power supply PWA. With this configuration, the two primaries of transformer T1 are wired in series, with F1 and F2 fuses in series to the circuit.

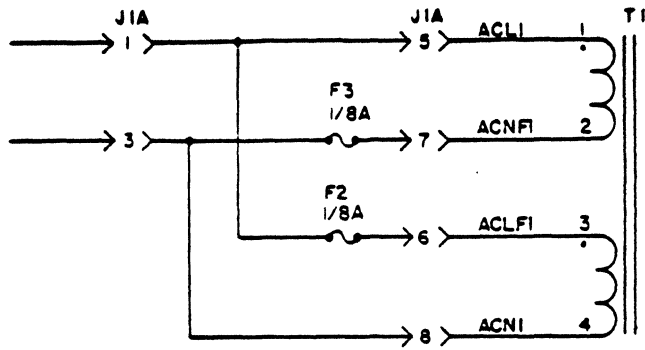

A. 120 VAC Power Input

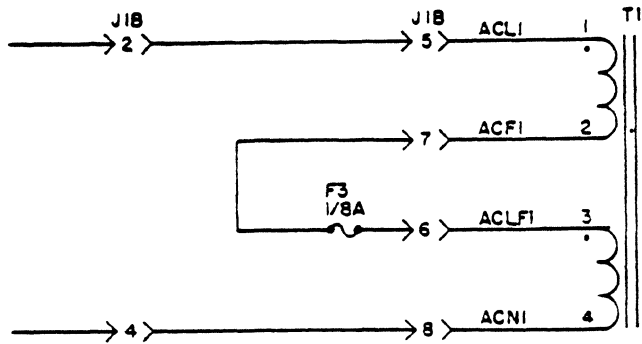

B. 220-240 VAC Power Input

Figure 4-4A. Voltage Select PWA  
(7701896X Series Power Supply)

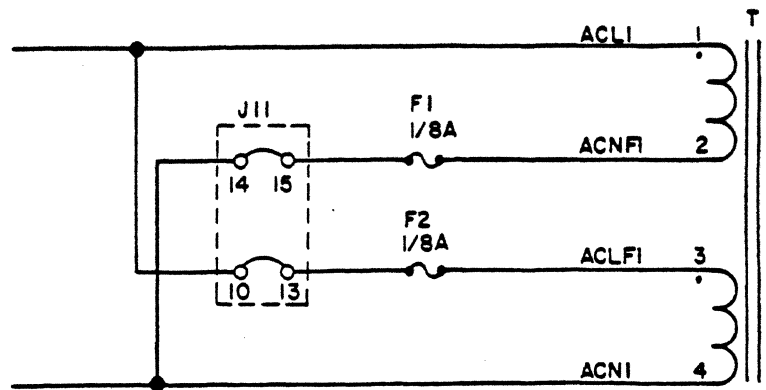

A. 120 VAC Power Input

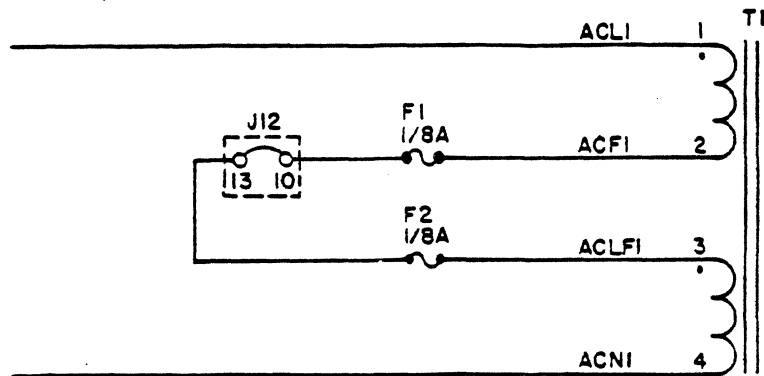

B. 220-240 VAC Power Input

Figure 4-4B. Voltage Select Plug  
(7702934X Series Power Supply)

Also, note that at this point (power applied, circuit breaker ON), the ac line is applied to the cooling fan motor. The cooling blower has a three-line input and is configured as shown for either 120 or 220-240 volt application. Wiring to the neutral line is determined in the voltage select PWA.

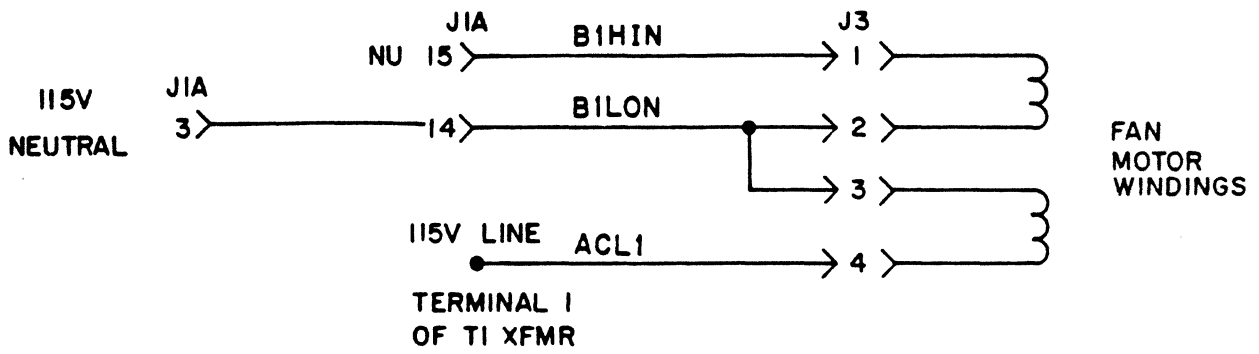

A. 120 VAC Power Input

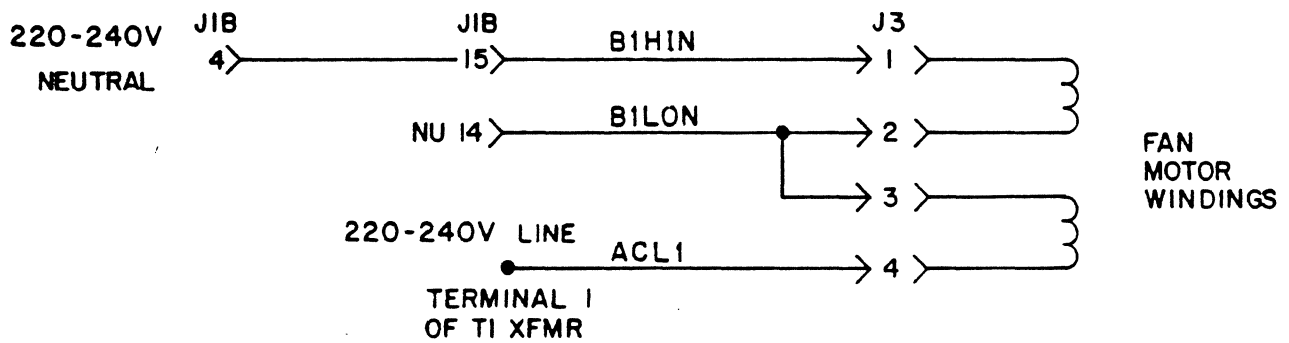

B. 220-240 VAC Power Input

Figure 4-5A. Cooling Fan Wiring  
(7701896X Series Power Supply)

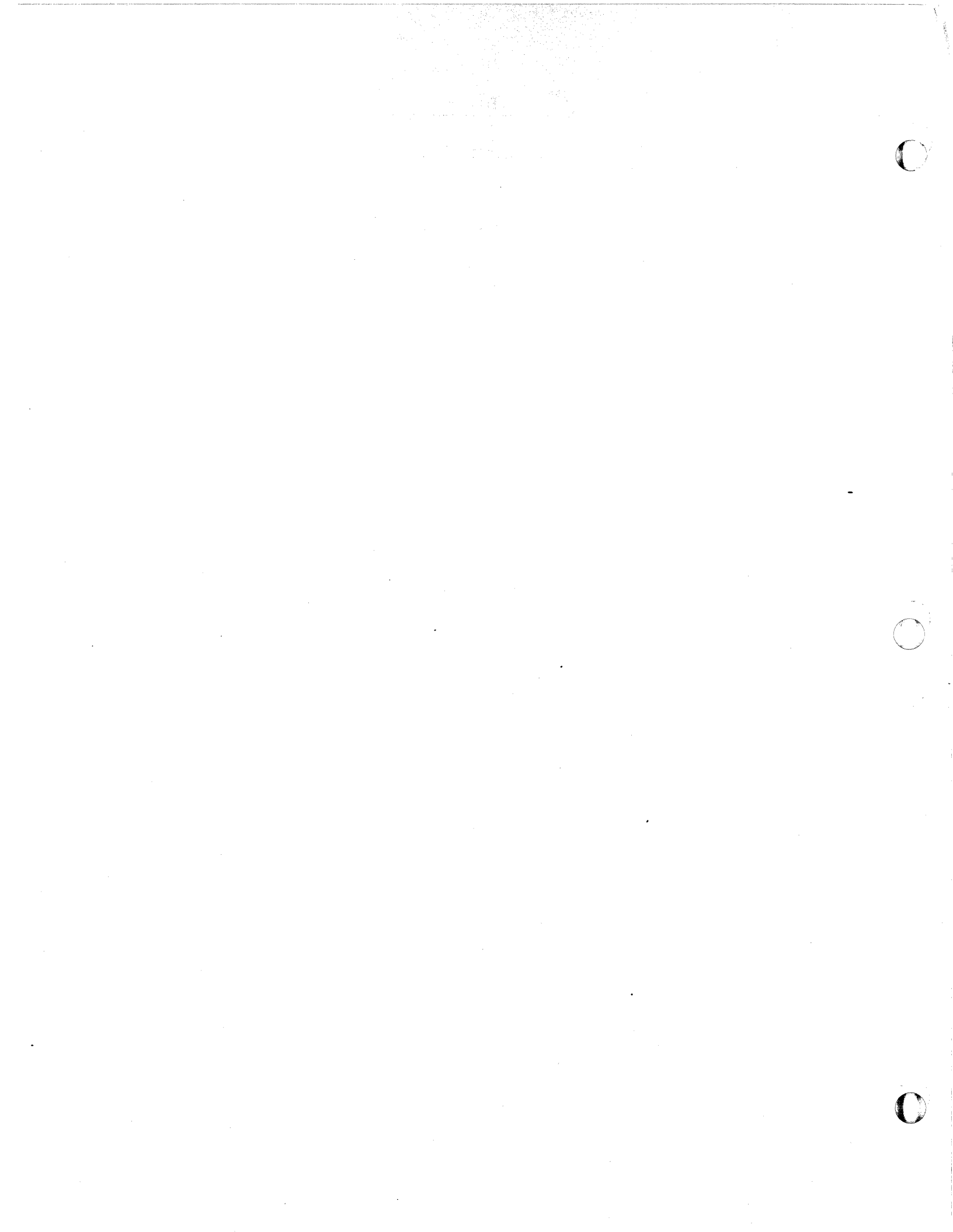



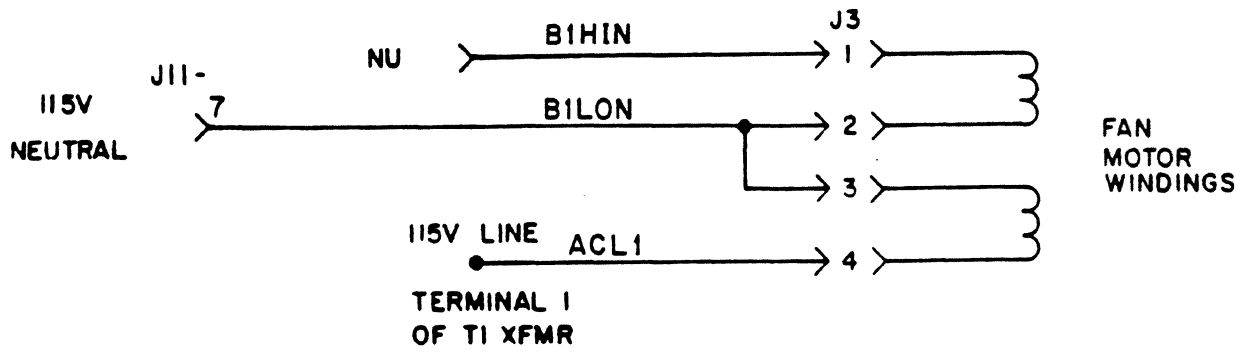

A. 120 VAC Power Input

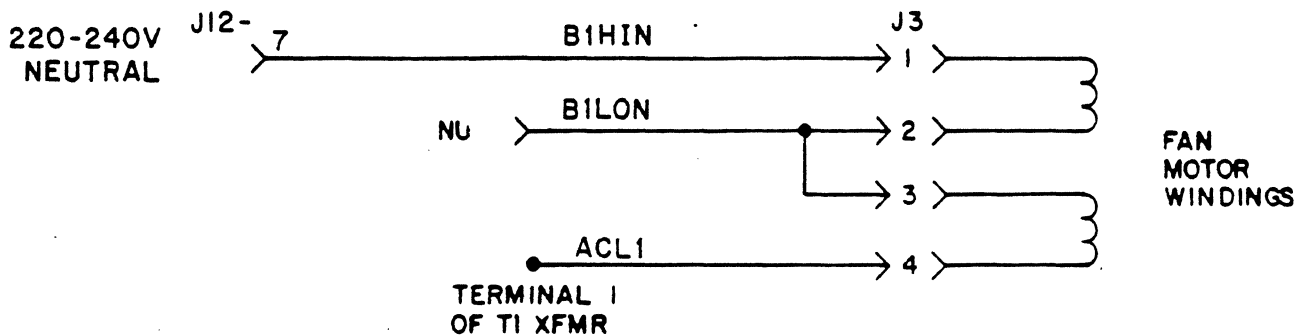

B. 220-240 VAC Power Input

Figure 4-5B. Cooling Fan Wiring  
(7702934X Series Power Supply)

### Standby Voltage Generation

Standby voltages of +20, +15 and +5 volts are developed to provide a separate supply voltage for all control circuits associated with the power supply. These voltages are present when input power is applied and the circuit breaker is placed in the ON position. Development of the standby voltage is as follows:

Input power is applied to the T1 standby transformer and converted to a +20 standby voltage via a full wave rectifier and filter network. The +20 VSB is used as a control voltage for the half-bridge switching converter and is used to develop the +15 standby voltage.

The +15 standby voltage is developed by a LM317 voltage regulator. The resistor divider network R3/R4 determines the required output of this regulator. Plus 15 volts is used as a supply voltage for the K-1 pump enable relay, K-2 current-on relay, pulse width modulator, over and under voltage detect circuits and master clear circuits, and is used as the source voltage to develop +5 standby voltage.

The +5 standby voltage is developed by a LM317 voltage regulator circuit similar to that used on the +15 VSB line. Plus 5 VSB is used as the supply voltage to operate all of the TTL chips used throughout the power supply. The Q3 transistor located between the +5 and +15 volt circuits is used in the event of the +15V supply being shorted to the +5 volt supply. If the +5V supply increases above 6.2 volts, diode CR36 would forward bias transistor Q3, causing a +5V potential at the resistor divider network of the +15 VSB voltage regulator. The +15 VSB regulator would then be regulated to approximately 6.2 volts, eliminating any damage that would otherwise occur to the TTL circuits fed by the +5V supply.

The only effect of the standby voltage outside the power supply is the LOGIC OFF indicator on the control panel. The power-on flip-flop (reset at this time) turns on the LOGIC OFF indicator transistor and supplies current limited (20 ma) +20 VSB to the LOGIC OFF indicator.

While in the standby mode, the ION signal is a logic 1 (high), keeping the pulse width modulator in a shut-down condition.

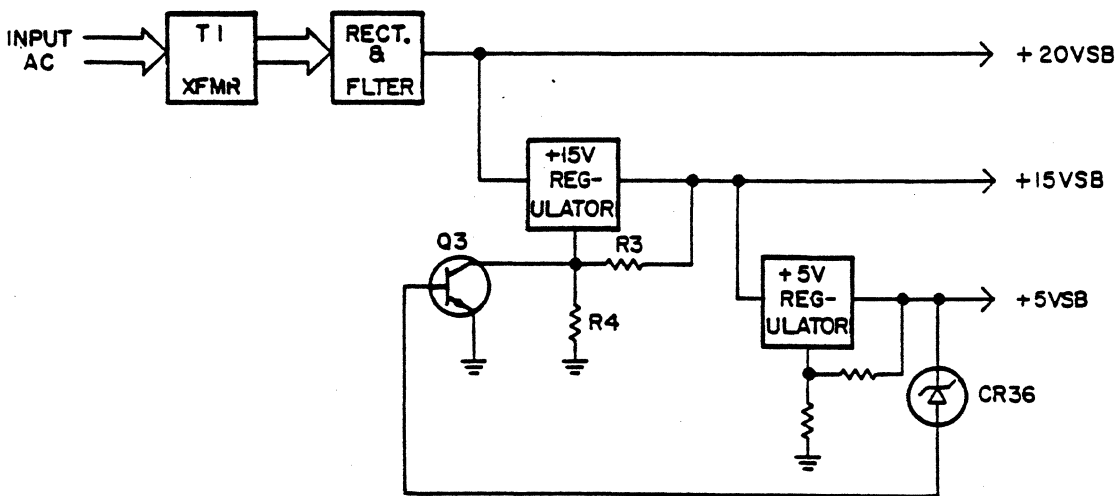

Figure 4-6. STAND-BY VOLTAGE GENERATION

## Power-On Sequence (refer to figure 4-7)

The purpose of the power-on function is to provide the required regulated dc voltages to the transport control, formatter, and servo circuits. The power-on sequence also enables the abnormal (low/over) voltage detect circuits within the power supply.

Power-on is initiated by pressing the main circuit breaker switch. This action causes a momentary turn on of the power-on transistor which triggers the POWER-ON flip-flop to the set state. The set output of the flip-flop removes the ION (low) signal from the pulse width modulator, enabling a 25 KHz pulse train output (DRIVE A/DRIVE B). These outputs are the control signals to develop the +5, -6, +15, +25 and +38 volt logic levels used throughout the transport. An explanation of the pulse width modulator and dc circuits are discussed in succeeding paragraphs.

Concurrent with the development of the dc voltages, the POWER-ON flip-flop also initiates a power-on delay, which is used to inhibit detection of low voltage until the dc voltages are expected to attain their nominal voltage level. The reset output of the POWER-ON flip-flop initiates a RC time delay of approximately 300 ms. This delay prevents the ON DLY flip-flop from setting which, in turn, forces the LVCHECK flip-flop to remain reset. At the conclusion of the 300 ms delay, a comparator triggers the ON DLY flip-flop. The LVCHECK flip-flop is now primed to receive a Low Voltage signal, if that condition is detected. Low voltage detection is discussed in succeeding paragraphs.

The ON DLY flip-flop also removes one of three inhibits from the master clear circuit.

The master clear (MCLR) circuit is provided to the transport logic to steer the control functions to a starting or known state during ON/OFF and other detected abnormal conditions. The MCLR circuit contains a time delay circuit of approximately 150 ms, which is used to assure output voltage stability prior to inactivating Master Clear. Three inputs are used to control MCLR: PON (power-on flip-flop), LOWV (low voltage), and ONDLY (on-delay flip-flop). The output of the MCLR is held low active during transitional periods, and is allowed to de-activate to a high level after all three controlling inputs are logic high.

At the conclusion of master clear, the ON LED transistor is turned on which applies +5V to the LOGIC ON indicator on the control panel.

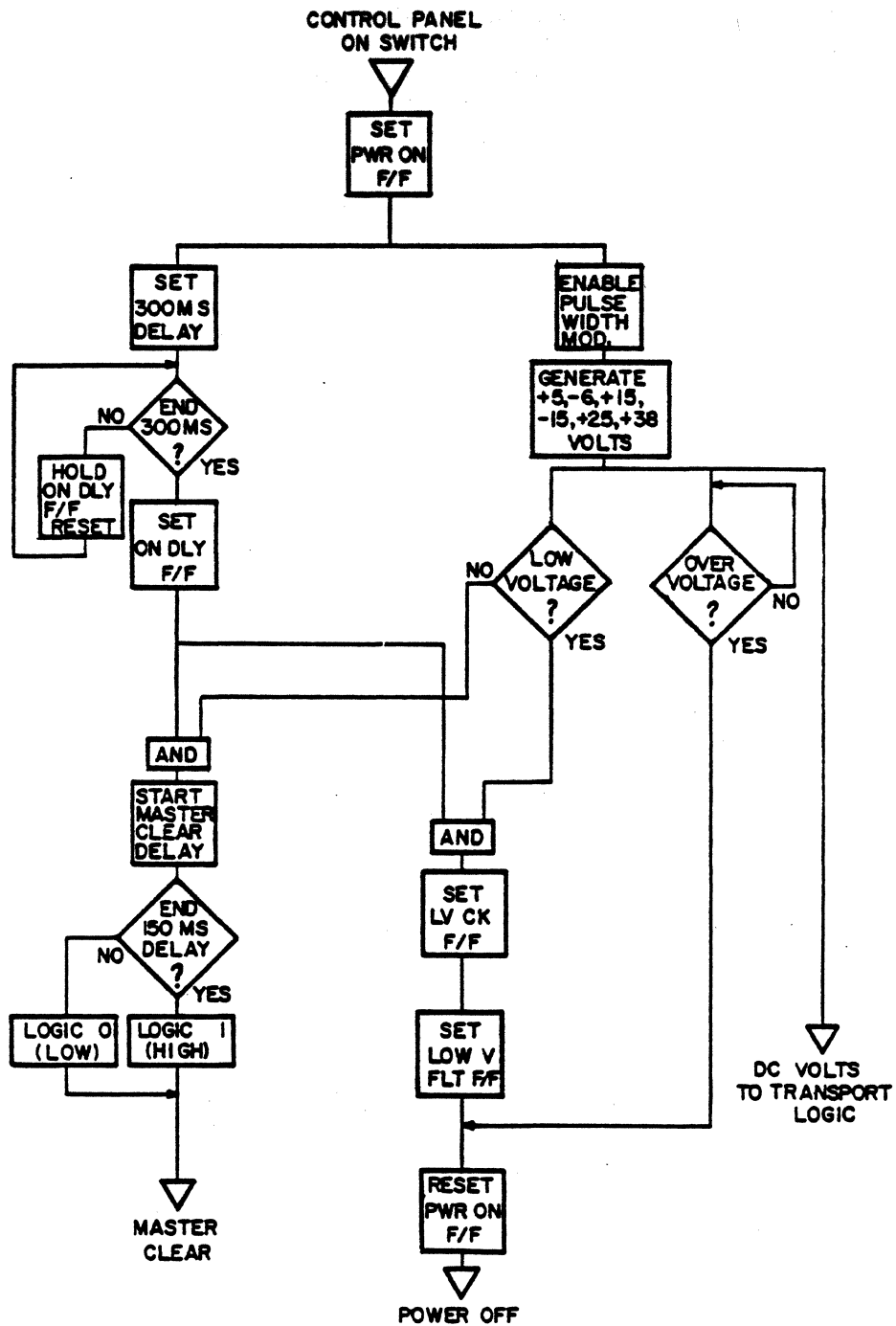

02A01-30

Figure 4-7. Power-On Sequence Flowchart

Switching Converter (Refer to figures 4-8 and 4-9)

The high voltage supply for the switching converter consists of two electrolytic capacitors charged through a diode bridge network. The output capacitors are configured so that during 120V operation the circuit functions as a voltage doubler, with the output capacitors connected in series. During 220-240V operation, the output capacitors are connected in parallel, and the input line is full-wave rectified. The resulting effect is that an output voltage of approximately 300V is supplied to the switching converter, regardless of whether 120V or 220-240 VAC is supplied. A simplified diagram of output capacitors and bridge configuration is shown in figures 4-8 and 4-9.

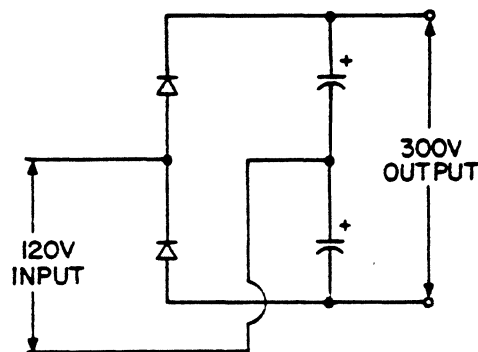

A. 120 VAC Input

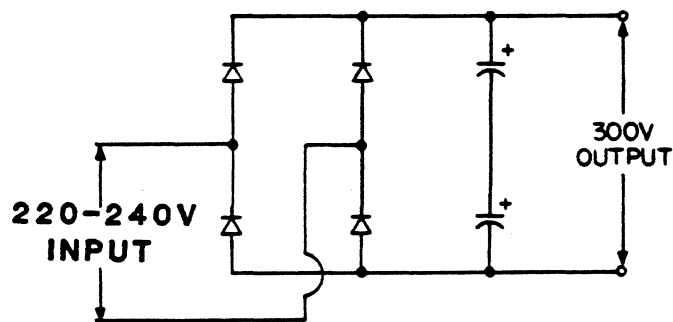

B. 220-240 VAC Input

Figure 4-8. High Voltage Generation

DRIVE A and DRIVE B (from the pulse width modulator) appear at the input of two peripheral drivers. These drivers, in the on state, positive input, provide a ground output. In the off state, the output is an open collector. An example of circuit operation is as follows: As the signal level of DRIVE B goes negative, driver output becomes an open collector. This provides a circuit from R12, +20 VSB, through the primary of transformer T2, to ground of the output of the opposite peripheral driver. With terminal 2 of T2 at a positive potential, an induced positive voltage is also present at terminal 10 of the secondary of T2, causing transistor Q1 to turn on. With Q1 turned on, a current path is now provided via Q1, T2 windings 5 and 6, and through the primaries of transformers T4 and T5. The induced voltage in the secondary of T4 and T5 is rectified, as described in the dc Voltage paragraph. During conduction of Q1, the current flow through T2 terminals 5 and 6 applies a "load proportional" drive current to base of Q1.

DRIVE B peripheral driver is turned on (ground output) when the DRIVE B signal returns to the high level. With both DRIVE A and DRIVE B in the on state, the primary of T2 is essentially shorted, causing Q1 to turn off. The charge stored in capacitor C10, during conduction of Q1, is applied as a back bias to Q1 when T2 is shorted. This ensures an immediate turn off of Q1 to produce the resultant waveform shown in figure 4-9.

When DRIVE A signal goes negative, the peripheral driver pin 3 outputs an open collector, and a current path is provided in the opposite direction through transformer T2 primary winding. Terminal 7 of T2 secondary now has a positive reference and Q2 is turned on. Current flow through T4 and T5 is now in the opposite direction via Q2 and T2 windings 5 and 6.

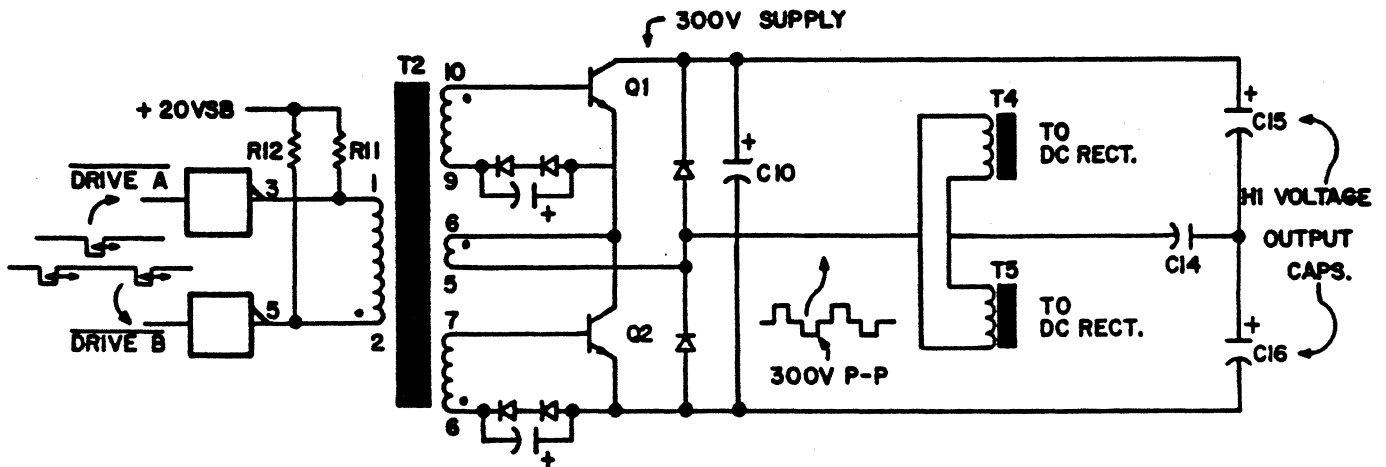

Figure 4-9. Switching Converter Circuit

## DC Voltages

The dc voltages generated by the power supply, for use throughout the transport, are as follows:

<u>VOLTAGE</u>	<u>USED ON</u>
+5V	All PWAs as a supply voltage for TTL circuits
-6V	Read Amplifier Circuits
+15V	Servos, Power Amplifier and Read Amplifier VFO
-15V	Servos and Power Amplifier
+25V	Write Driver Circuits
+38V	Power Amplifier

All dc voltages are generated and regulated in a similar manner. The output of the secondary windings of the Switching Converter transformers T4 and T5 are inputted to a full wave rectifier and filtered by a choke/capacitor filter network. Negative 6 volts and + 15 volts are regulated by LM317 and LM337 voltage regulators, with resistor divider networks providing the required regulator programming. Plus 5 volts circuit does not require a voltage regulator due to the compensation circuit supplied by the pulse width generator discussed previously.

## Low Voltage/Over-Voltage Detection

The detector circuits consist of the various dc input voltages, voltage divider resistor networks, +2.5 reference voltage and LM339 voltage comparators. If any of the input dc voltages exceed the circuit threshold set up by the resistor networks and reference voltage, the comparator outputs a ground potential. This output then initiates a shut-down of the transport power supply. If the voltages are within the parameters listed below, the comparators have open outputs.

<u>NOMINAL VOLTAGE</u>	<u>LOW VOLTAGE THRESHOLD</u>	<u>OVER-VOLTAGE DETECTION</u>
+5V	+4.53	+6.0
-6V	-5.0	-6.96
+15V	+12.58	+17.25
-15V	-12.58	-17.25
+25V	+21.25	+28.13
+38V	+25.25	+50.3

## Power Supply Shut-Down

There are two circumstances which cause the transport to power-down. They are an over-voltage condition and a low-voltage condition.

## o Over-Voltage

When an over-voltage condition occurs, the voltage comparators of the detection circuit output a ground potential. This ground signal (labeled OFF) resets the power-on flip-flop. Signal ION becomes a logic 1 (high), causing the pulse width modulator to shut down. With no output from the modulator, all dc voltages to the transport are dropped. Concurrent with the shut-down of the pulse width modulator, the MASTER CLEAR signal goes to a logic 0 (low), thereby resetting affected circuits in the transport logic. The LOGIC OFF indicator on the control panel is lit by the shut-down condition.

## o Low Voltage

When a low voltage condition occurs, the voltage comparators of the detection circuit output a ground potential. This ground signal (labeled LOWV) sets the low voltage check flip-flop, if the ON DLY FF is set, causing LV FAULT FF to set which results in the power-on flip-flop going reset. With power-on flip-flop in the reset state, the power supply is shut down in the same manner as described in the over-voltage discussion above.

## PNEUMATIC SYSTEM

### FUNCTIONAL DESCRIPTION

The pneumatic system generates and distributes the air pressure and vacuum requirements of the transport. The pneumatic system consists of a carbon-vane centrifugal compressor, tape cleaner intake port, filter/regulator assembly, and pressure ports of the air bearings.

The compressor is enabled by the microprocessor during the load sequence. A PUMPEN signal from the logic energizes K-1 relay located in the power supply. The contacts of K-1 relay triggers a triac which gates the single phase input power to the pump motor. Motor wiring is configured for 120 or 220-240 volt input via the voltage select PWA in the power supply.

With the compressor motor operating, the air intake (vacuum) side of the pump is from the tape cleaner assembly. Refer to figure 4-10 for a block diagram of vacuum and pressure distribution. In addition to the tape cleaner intake, a small bleeder hole exists on the elbow fitting between the compressor and the plastic hose from the tape cleaner. The vacuum effect at the tape cleaner is approximately 8.0 inches H<sub>2</sub>O.



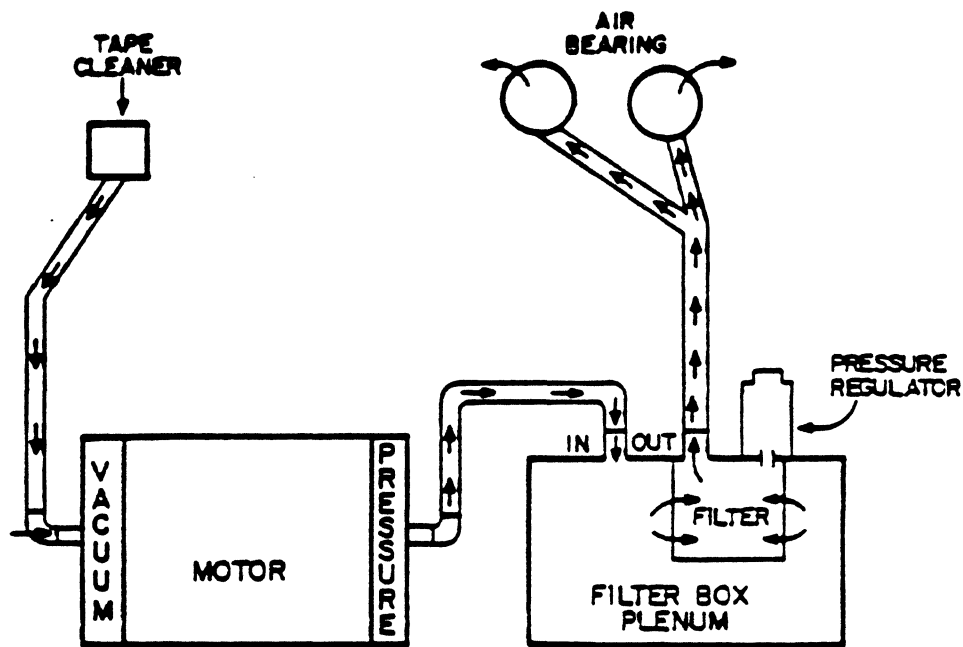

Figure 4-10. Vacuum and Pressure Distribution

The regulator portion of this assembly is a spring-controlled valve that causes any pressure above 2.3 PSI to be bled out of the system. The air pressure is filtered by a high efficiency particle accumulator to clean the air prior to application to the air bearings. Air is forced through the filter and a hollow shaft. One end of the shaft is open and contacts the bleeder valve so that pressure in excess of 2.3 PSI is removed. The inside area of the filter (now regulated to 2.3 PSI) is applied to the deck plenum which directs the air pressure to the air bearings.

#### PNEUMATIC SYSTEM OPERATIONAL DESCRIPTION

Operation of the pneumatic system is obtained via the power supply by the presence of 15 VSB and low active -PUMP signals. Together, these signals energize K-1 relay and trigger triac CR8. The output of triac CR8 provides the pump with the single phase operating voltage.

Figures 4-11A and 4-11B illustrate motor wiring configurations for 120 or 220-240 volt inputs via the voltage select PWA in the power supply.

**V.S.B 120V APPLICATION (J1A)**

**PUMP MOTOR**

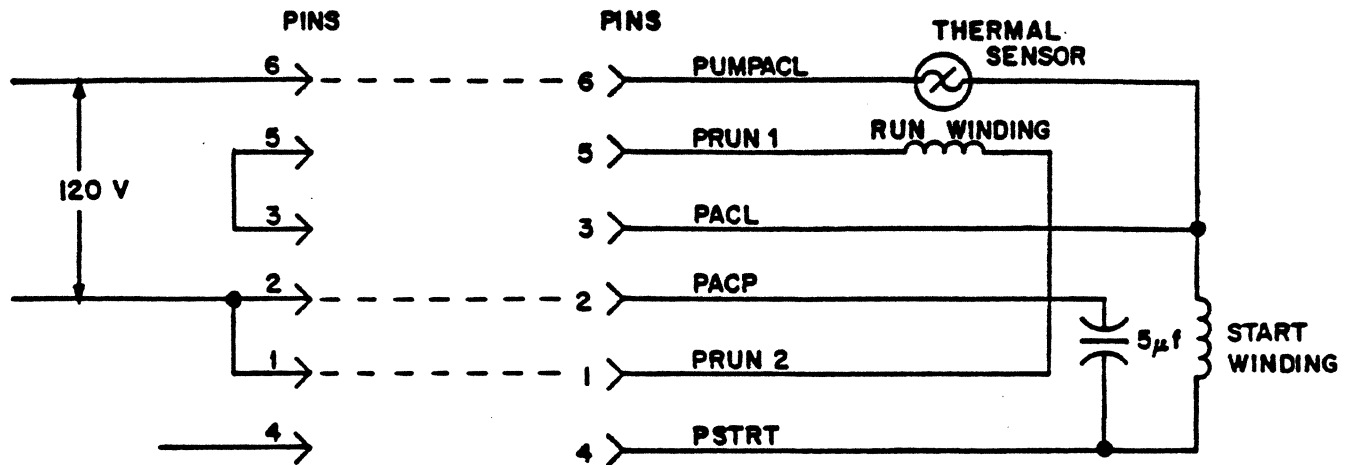

Figure 4-11A. Compressor Wiring 120 VAC Configuration

**V.S.B. 220-240V APPLICATION (J1B)**

**PUMP MOTOR**

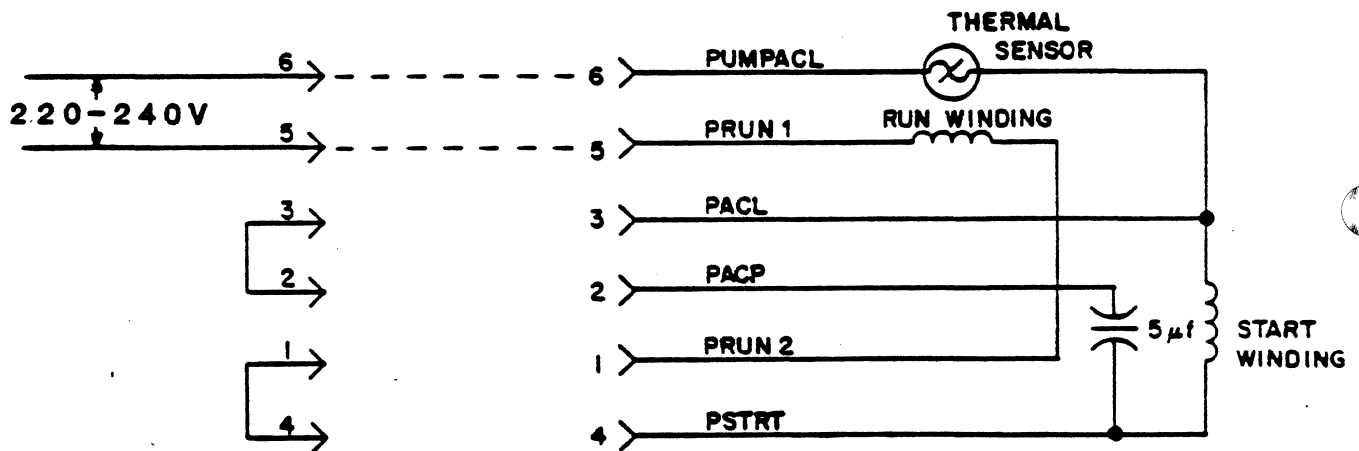

Figure 4-11B. Compressor Wiring 220-240 VAC Configuration

In the 120V mode of operation, single phase input power is applied to the motor via pins 2 and 6 of connector P2. During initial motor start-up, an external 5 uF capacitor is utilized to create a phase difference. In this configuration, the capacitor is connected in series with the start motor winding.

In the 220/240V mode of operation, single phase input power is applied to the motor via pins 5 and 6 of connector P2. During initial motor start-up, an external 5 uF capacitor is utilized to create a phase difference. In this configuration, the capacitor is connected in parallel with the start motor winding. For both configurations, the pump motor contains a self-recovering thermal sensor.

## SERVO-CONTROL PWA FUNCTIONAL DESCRIPTION

### GENERAL INFORMATION

The servo-control PWA has four main functions in the overall operation of the transport. They are as follows:

- o Formatter Commands/Responses
- o Transport Control/Monitoring
- o Control Panel Command Execution
- o Tape Motion/Servo Control

### Formatter Commands/Responses

The transport must accept, validate, and dispatch for execution commands transmitted by the formatter. For commands such as WRITE and READ REVERSE, the PWA must determine, sequence and monitor the necessary tape motion to complete these commands. Communication between the formatter and transport is controlled by the respective servo/control and formatter write PWA microprocessors.

### Transport Control/Monitoring

The servo/control PWA must respond to each of the outputs generated by the various sensors located throughout the drive. Some of the responses include BOT/EOT, FILE PROTECT, updating of the take-up reel radius dependent parameters, and the initiating of a verification sequence for a potential fault condition.

### Control Panel Command Execution

The servo/control PWA communicates with the operator or customer engineer through the control panel to allow execution of manually initiated commands. These commands include the loading and unloading of tape or the executing of various diagnostic tests.

### Tape Motion/Servo Control

In addition to the global activity of overseeing tape activity, the servo control logic becomes embedded in the take-up reel motor servo during stoplock and tape acceleration/deceleration. The servo/control PWA monitors tape speed and provides compensation for under/overspeed conditions to ensure constant speed during all tape motion operations.

## SERVO-CONTROL MICROPROCESSOR

The 6809 microprocessor is the controlling entity on the servo/control PWA. The microprocessor features include two 8-bit accumulators forming a 16-bit accumulator, two 16-bit index registers, a user stack pointer, a hardware stack pointer, and an 8-bit direct page register. The microprocessor has no internal RAM, is operated off a 4 MHz crystal, and has three-level priority interrupt inputs. All inputs and outputs of the 6809 and all other devices on the microprocessor bus are TTL compatible. Output or bi-directional devices connected to the microprocessor bus have tri-state drivers which are enabled only as a function of the microprocessor, E and Q clock outputs.

The input, output, and control lines extend out to the various peripheral and memory devices. Device selection is obtained by decoding a portion of the microprocessor address bus and gating it with the E and Q clocks.

A 6821 peripheral interface adapter is used for communication between the servo/control microprocessor and formatter write microprocessor. The PIA's 16 bi-directional, peripheral data lines (ports A and B), interrupt line (CA1), and peripheral control (CB1 and CB2) are used to establish a hand-shake communication between the two PWAs. The drive microprocessor gains the attention of the formatter by use of the INTR line which causes the formatter to interrogate the drive status/sense to determine cause for the interrupt.

In order for the processor to count servo tachs (forward and reverse) for tape acceleration, to maintain positional information during repositions, and to provide a real-time clock for the processor, two 6840 programmable timer PWAs are attached to the microprocessor bus and control lines. The PTM contains three 16-bit counters which provide various modes of operation including squarewave generation, gated delaying of signals, digital single-shot pulse generation, and pulse width modulation. The counters decrement on each clock period.

The functional and diagnostic programs for the processor reside in two read-only-memory (ROM) chips. When the ROM is enabled by the processor (through the address decoder), the data relative to the current processor address is conveyed to the data bus by the ROM within one microprocessor cycle time.

Various medium scale integration (MSI) devices are attached to the processor data and address bus to allow the microprocessor to interface to the servo, read, and write hardware. The MSI devices consist of bit input multiplexers, bit output latches, byte output latches, and related address decoding devices.

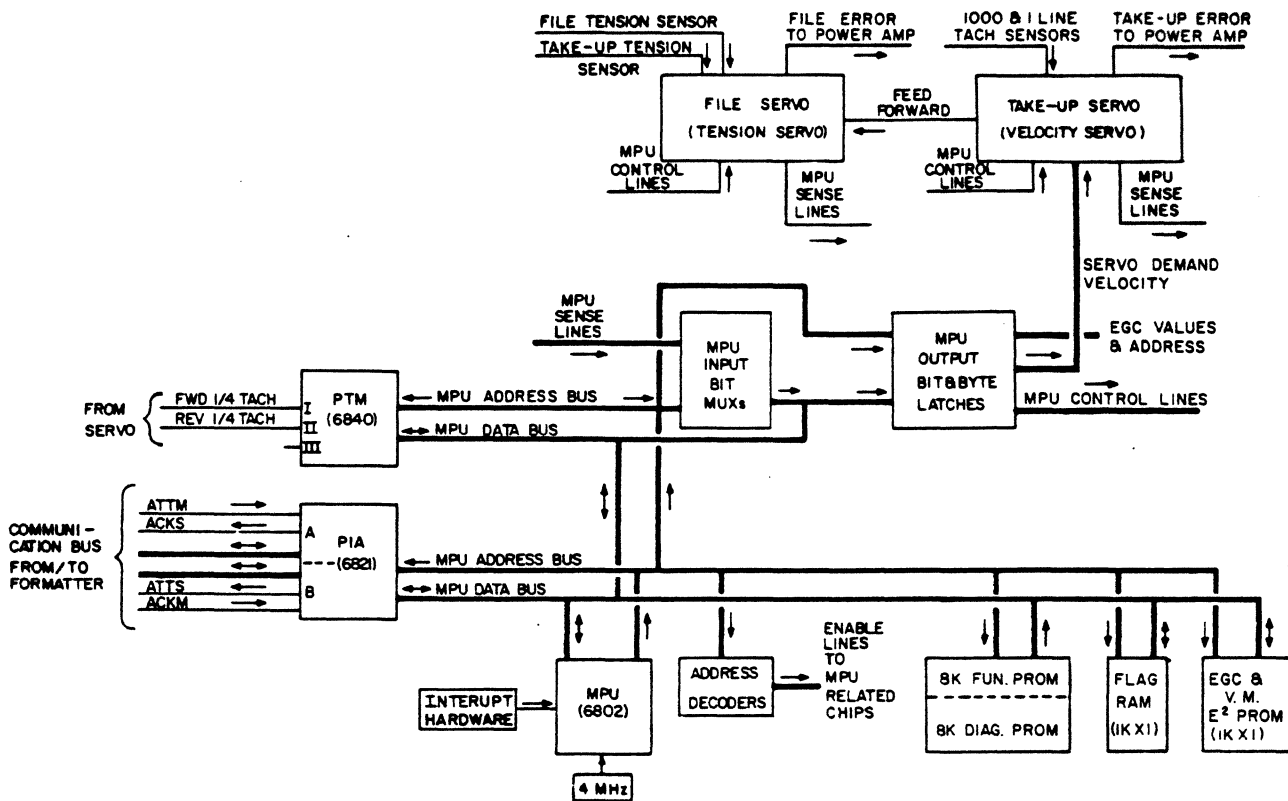

Figure 4-12. Servo/Control Block Diagram

Single input data bits are passed through the bit input multiplexers to the microprocessor data bus bit 7 (the most significant bit), upon selection of an input multiplexer. The selection of a given data bit and multiplexer is dependent on the address conveyed by the microprocessor to the multiplexer and address decoding devices.

Bit output latches are used to convey bytes of data from the microprocessor to the hardware. No connection to the microprocessor data bus is made. The selection of a given bit output latch is dependent on the address conveyed by the processor to the latch and address line decoding devices. All latches are reset by the master reset line.

Byte output latches are used to pass bytes of data from the processor to the hardware. Output data is derived from the microprocessor data bus upon a write operation to the byte output latch address. The selection of a given byte output latch is dependent on the address conveyed by the microprocessor to the address decoding devices.

A non-volatile, 1K x 1 bit static RAM (E<sup>2</sup> PROM 2201A) is attached to the processor to provide both a means of storing the read amplifier gain values, velocity servo gain adjust multiplexer and write driver current levels, and a means of storage of flag bits used by the microprocessor to retain transport status. A two-position jumper is provided to prevent unintentional changes to the data contained in the E<sup>2</sup> PROM. Data can be transferred to the E<sup>2</sup> PROM only with the jumper in the STORE position.

### VELOCITY SERVO

The velocity servo consists of a digital-to-analog converter (DAC), decode flip-flops connected to a digital tachometer, operational amplifiers, and three presetable counters. The DAC converts 8 bits of information labeled demand velocity (DMDVEL) into a signal proportional to the desired velocity. The demand velocity can vary from 0 to 255 with complete control at any speed. The DAC output at 25 ips is 1/2 volt per radian per second. A radian per second is derived from the linear tape velocity (ips) divided by the radius of the take-up reel.

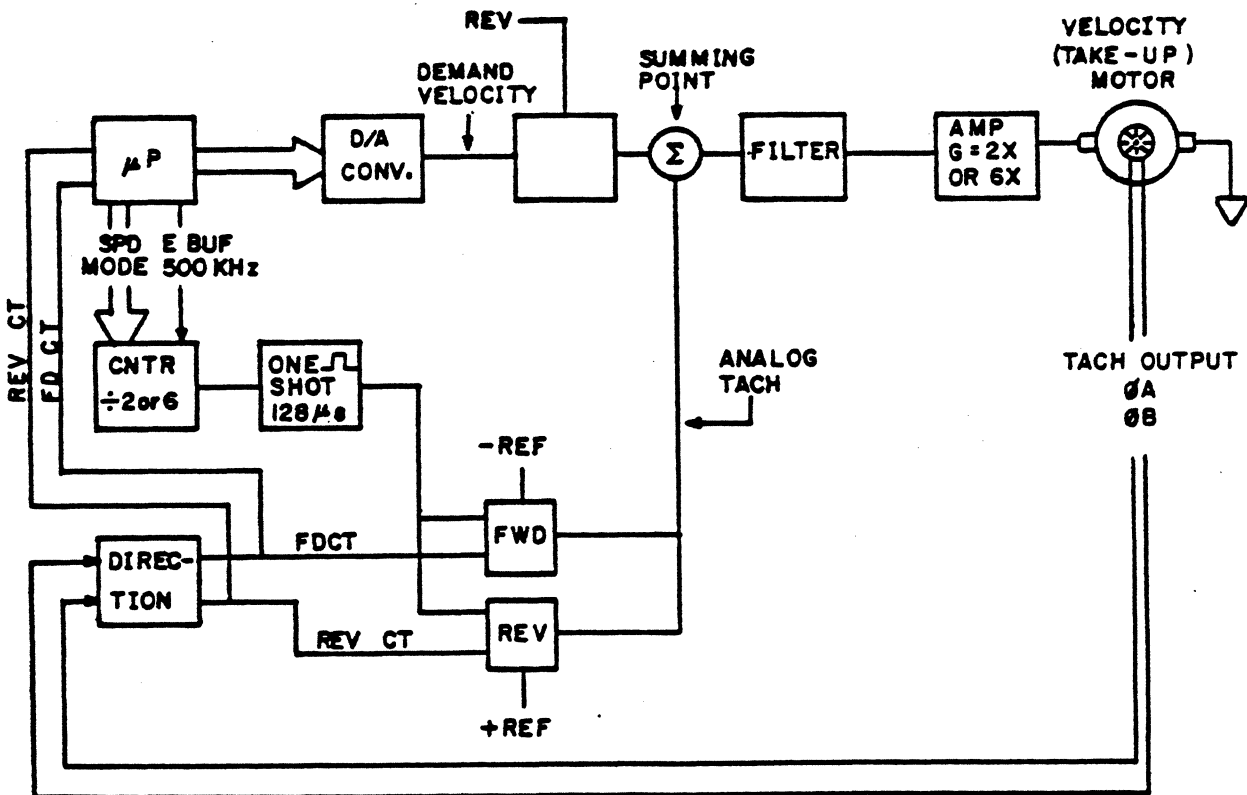

Figure 4-13. Velocity Servo - Simplified

At the beginning of tape (BOT), the radius is 2.56 inches. At the end of tape (EOT), the radius is approximately 4.9 inches when using a 2400 foot reel of tape. The voltage at the output of the DAC is approximately 4.88 volts at 25 ips (speed divided by 2.56 inches) at BOT and 2.5 volts at EOT. The voltage at the DAC output will not change when 75 ips is selected, however, the rotational speed will change accordingly. The signal REV determines the polarity of the analog demand velocity signal for rotation of the take-up motor in each direction.

Rotational velocity is generated and referred to as "analog tachometer" (ANALOG TACH). The analog tach (TP9) is also proportional to 1/2 volt in the 25 ips mode. In the 75 ips or rewind mode, the analog tach is less than the rotational speed. The analog tach is derived from the 2-phase, 1000-line tachometer physically mounted on the rear of the velocity motor. The output signals, phase A and phase B, are decoded into direction and divided down (depending on the speed selected). The divided tach triggers a 128 microsecond one-shot. The decoded direction is logically ANDed with the 128 microsecond one-shot and then filtered to become the analog tach.

The analog tach is subtracted from the demand velocity and compensated with a lag-lead filter. This signal is then multiplied by 2 or 6, depending on the speed, and becomes the take-up error (TUER). The take-up error is proportional to the desired current in the velocity motor and is equivalent to 1.0 volt per amp.

#### TENSION SERVO

Refer to logic diagrams located in section 5 and block diagrams for circuit identification.

The tension servo system is comprised of two tension servo transducers, input operational amplifiers, reference voltage inputs, take-up motor error input, summing circuit, analog switch circuit for mode selection, and above/below tension level comparators for servo shut-down in the event of component failure.

The two tension sensors are located on either side of the magnetic head. One sensor is located between the velocity servo motor (take-up reel) and the magnetic head, and the second is located between the tension servo motor (supply reel) and magnetic head.

During a load sequence, prior to starting the pump motor, the microprocessor sweeps TTENOFF and FTENOFF levels from their maximum voltage to the minimum voltage. At the point at which the TTENOFF and FTENOFF zero their respective operational amps, the TTENZERO and FTENZERO signals toggle causing the microprocessor to stop the changing sweep levels. The effect of this action is to determine the point at which both tension transducers have a zero offset. The microprocessor maintains the TTENOFF and FTENOFF levels at the determined offset until the next load sequence.

The inputs to the tension servo circuit are TTENTRANS, FTENTRANS, + REF and TUER. The TTENTRANS and FTENTRANS signals come directly from the tension sensors with a signal input proportional to the variance of tension felt by the sensor. The tension reference is derived from a 6.9 volt supply and a 1.78M ohm resistor. This reference voltage is equivalent to 16 ounces of tape tension, and is used to bias the circuit so that 8 ounces of tension is developed. The fourth input is the TUER signal and is proportional to the current in the take-up motor at any given time.

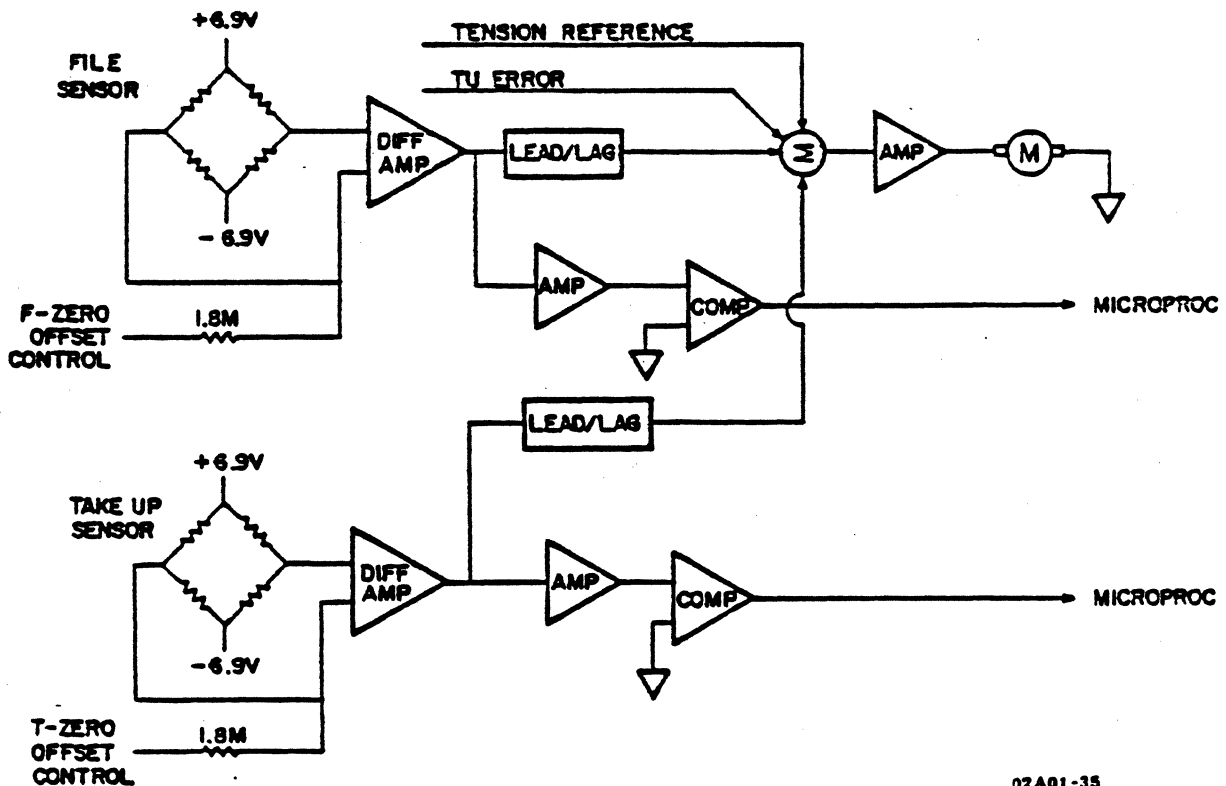

Figure 4-14. Tension Servo - Simplified



At an optimum condition, where both sensors are sensing 8 ounces of tension, the 16 ounce (+ REF) reference is effectively neutralized. The only dynamic effect on the circuit, at this time, would be the action of the take-up reel motor. With the TUER being summed with the neutralized tension/reference voltage inputs, the tension motor (supply) reacts proportionally to the current in the take-up motor, as indicated by TUER.

Any variance in tape tension would cause a change in the sensor op amps' outputs. This voltage output is subtracted from the tension reference, with the result summed with TUER. The difference of all these signals is multiplied by a high gain amplifier when tape is in motion.

The PRKD input term to the tension servo is active during a Parked or No Tape Motion condition. With PRKD active, the operational amplifier used as a high gain multiplier, after the summing network, is switched to a low gain amplifier.

The above/below tension limit protection circuits consist of a series of comparators, with inputs referenced to predetermined voltage levels corresponding to high or low tension levels. If above or below tension levels are sensed on either of the tension sensors, the microprocessor is notified via signals TAUTL, TBLTL, FAUTL or FBLTL and a shut-down of the servo is initiated. Refer to figure 4-12 for a simplified presentation of this circuit.

#### POWER DRIVER PWA

The function of the power driver PWA is to convert voltage error values received from the servo/control PWA into proportional currents driving the take-up motor and the supply (file) motor. The torques created by the motors are applied as acceleration and tension to the tape between the two motors. The power driver electronics assembly consists of two identical amplifiers. The operation of one amplifier is described below.

The driver has an H-bridge voltage switcher driven by a pulse width modulation (PWM) converter contained within a current feed-back loop. The resulting current is uninterrupted, but varies with an average value proportional to the input voltage, with a gain factor of 1 amp per volt. A soft dead-band of + 300 mv exists where the gain factor quickly approaches zero within this region of input.

An overall block diagram is shown in figure 4-15. The signal flow proceeds from the differential error input through U1 with unity gain summing, with the current feed-back voltage from U2. The resulting difference is multiplied by five through U3 and compared to two triangle voltages by comparators U4 and U5. These waveforms are shown in figure 4-16. Two quadrants of input are shown to point out that only one of the negative-active outputs from U4 and U5 exists at any given time. The peripheral drivers U6 and U7 connect the PWM outputs from the comparators to the appropriate transistors Q1 through Q4. At this point, it can be seen how the enabling to the H-bridge is performed. The gating of SVPEN and SVEN allow diagnostic control. The SW5 signal (Switched +5 Volts) is applied as the source of drive to the lower bridge. It can be quickly removed during Power On and Off sequencing or during a high over-current condition.

The circuitry for providing SW5 is shown in figure 4-15. Motor current is sensed through the appropriate resistor R1 or R2 and connected to U2 through a low-pass filter. The filter removes switch-over spikes caused by shorting currents through commutating diodes CR1 through CR4 and non-aligned switching times of the two transistors in any one diagonal. The filter plays no part in compensation for loop stability or rejecting the 20 KHz current ripple.

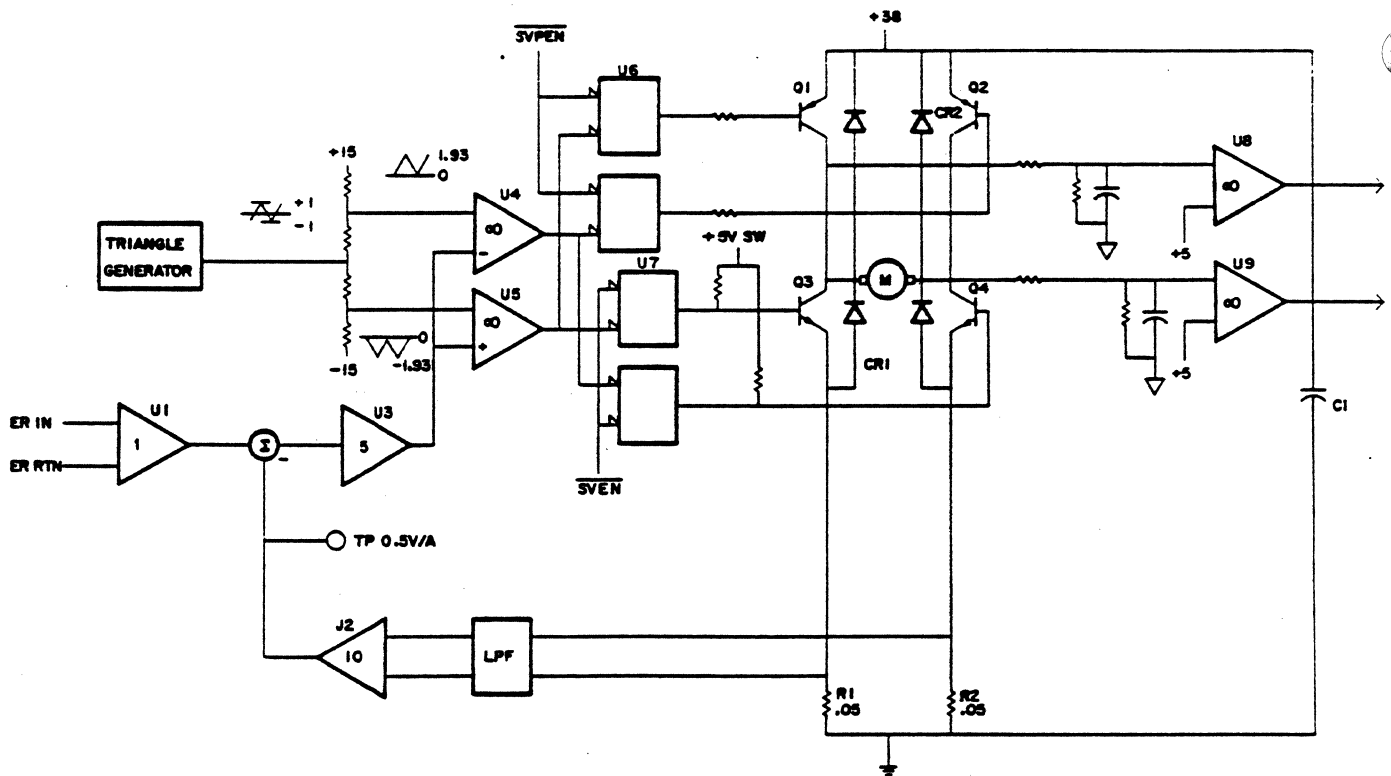

Figure 4-15. Power Driver Block Diagram

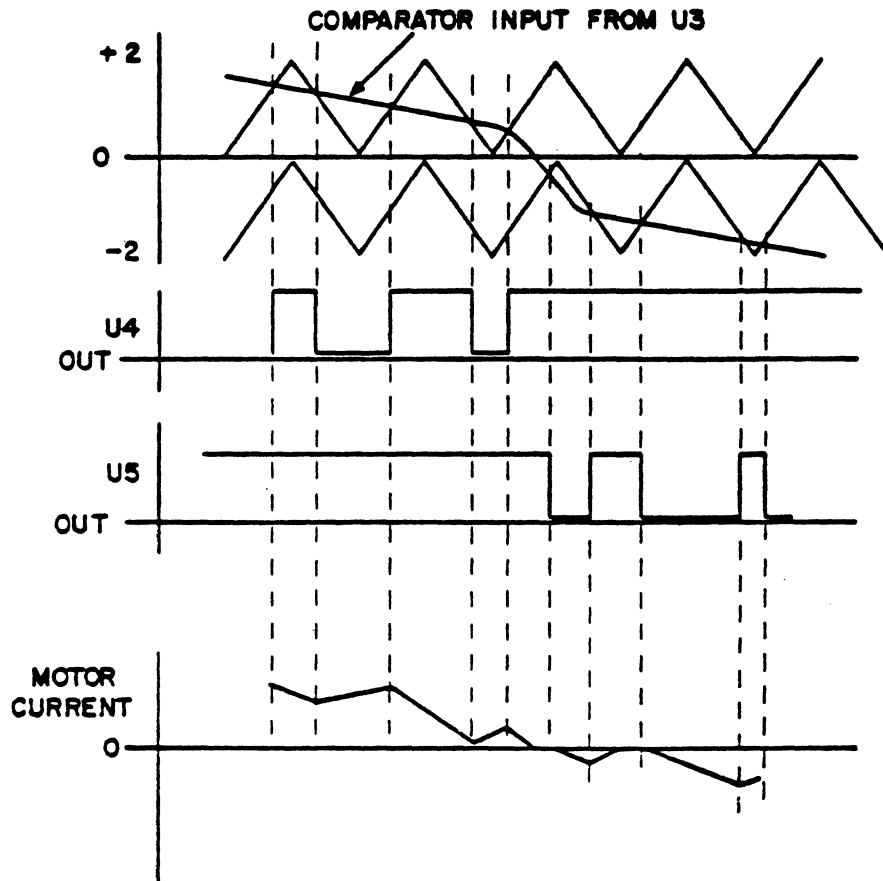

Figure 4-16. Power Driver Waveforms

Figure 4-17 shows a quadrant of the H-bridge and the states of current flow for a given dc input. In state 1, current is flowing in Q1 and Q4, 'charging' the motor. In state 2, the motor is 'discharging' through CR1 and CR2 and through CR3, thus charging C1. Capacitor C1 is discharging during state 1; the capacitor is charged by the power supply during state 2.

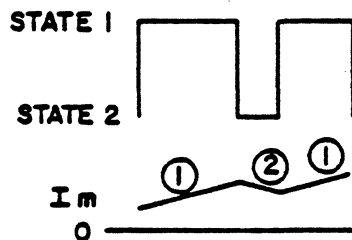
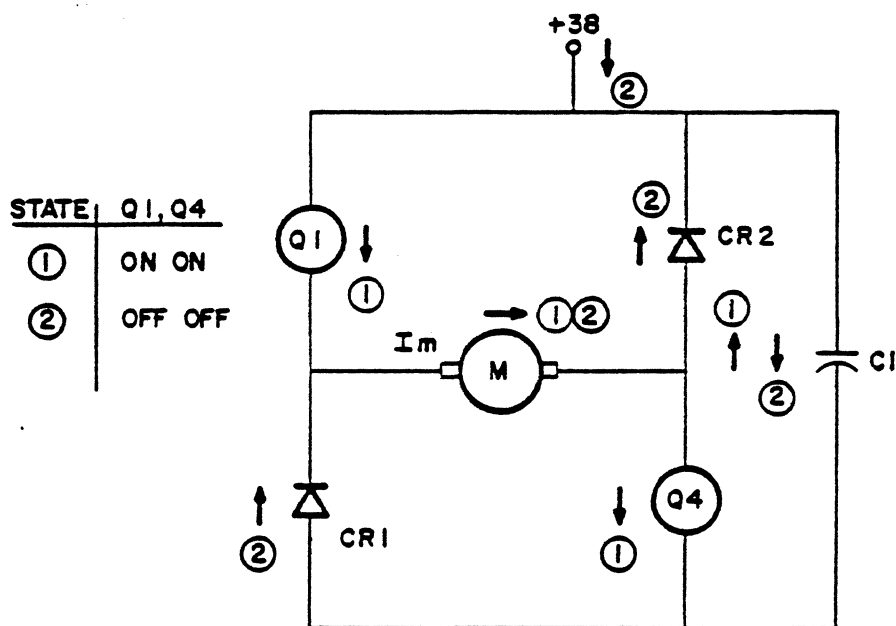

Figure 4-17. H-Bridge Switching

A block diagram of the Switched 5-Volt line for biasing the lower stages of the H-bridge, and also the peripheral drivers for biasing the upper stage, is shown in figure 4-18. The 5-volt shut-down is needed because the peripheral drivers become uncontrolled below 4 volts, thereby turning on both sides of the bridge in the presence of 38 volts. The MASTER CLEAR signal from the power supply and the 4.2 volt reference make use of comparator U4 for shut-down.

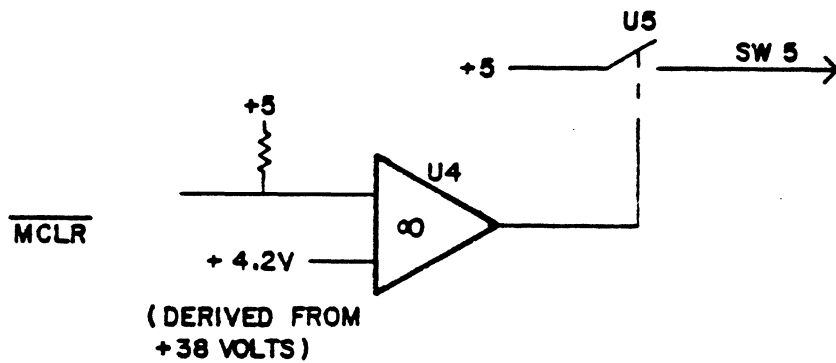

Figure 4-18. Switched +5 Volts

## WRITE DRIVER PWA

The function of the write driver PWA is to convert the digital data received from the formatter to an analog write current for writing data on tape. The write driver contains the necessary control circuits for generating the required voltages and currents used internally to perform the write data function.

## WRITE CONTROL

The control circuits are enabled by the absence of both FILE PRO and REWIND as shown in the write control block diagram (figure 4-19). The absence of these signals, along with a +24 volt supply, turn on transistors E1/Q1, outputting a voltage greater than +22 volts. This voltage is used along with ERASE to enable erase head current and the erase current detect output at TP2. The +22V is also an input to a voltage regulator for generation of +15V. This voltage is used to enable the ac bias generator and also develops, through F1/G3 transistors, the +15 WE and +5 WE supply voltages.

Write current is sensed by the voltage developed across a 10 ohm resistor so that write current (-WR CURR) is a logic low when write current is flowing through the head coils.

The erase circuit is enabled by ERASE when FILE PRO and REWIND are not true. F1 transistor turns on allowing erase current to flow through the erase head coil.

A +5V fault detect circuit consists of a differentiator with inputs of +5V and +5VR. Any variance of the +5V input will cause the collector output of Q1 to go from +22V to 0 volts, thus removing the write driver supply voltages and shutting down the write current.

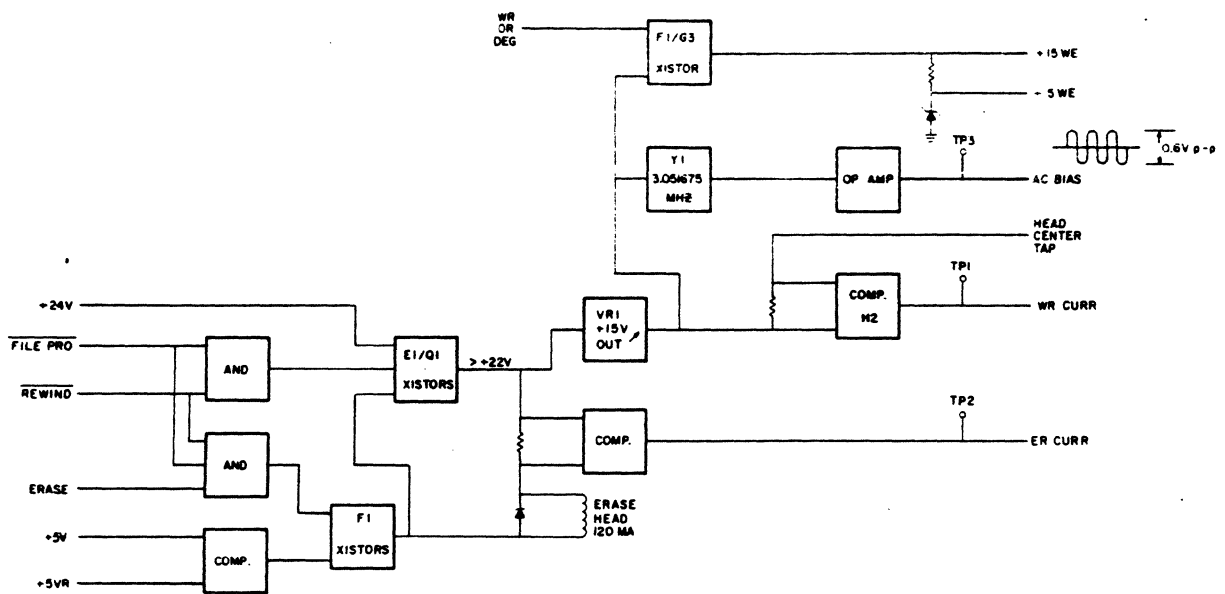

Figure 4-19. Write Control Block Diagram

## WRITE DRIVER LSI

The write driver is a large scale integrated (LSI) circuit designed to output a write current with a step and ac bias. The waveform of the write driver is the summation of ac bias current, step current, and write current. The transistors used on the drive 1 and 2 outputs of the LSI are voltage amplifiers used to amplify the relatively low voltage drive outputs to the write head coils.

The data pulse output of the LSI is used to trigger an external timing circuit. The output pulse width of timer B4 is dependent on the resistor selection through a multiplexer, which is gated by high or low speed and PE or GCR operating modes. The output pulse determines the write compensation times for the write driver.

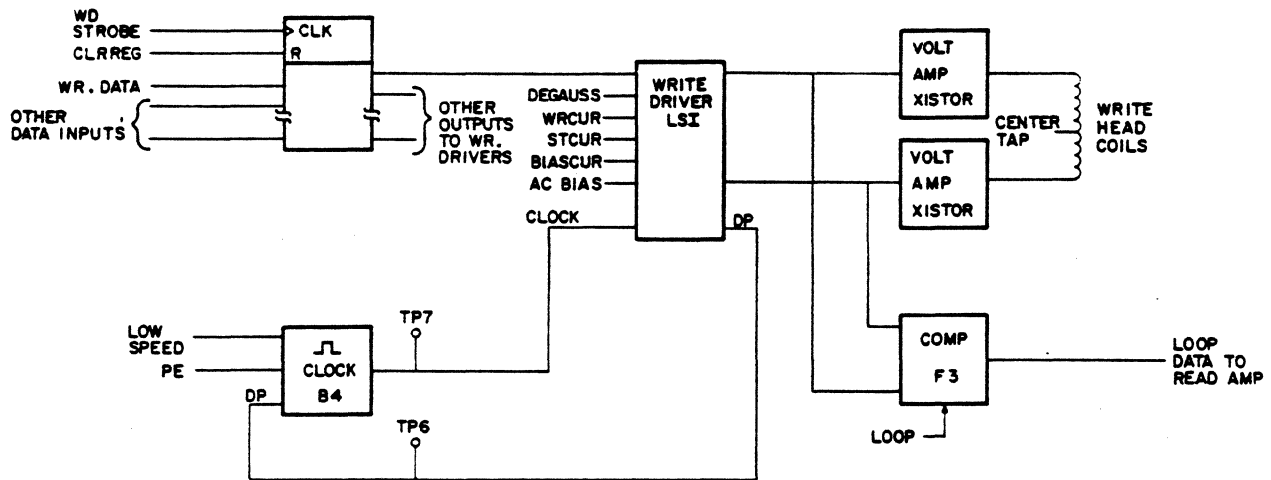

Figure 4-20. Write Driver Block Diagram



## DEGAUSSING

During a write operation, current flow through the write head causes residual magnetism to build up around the write coils. If the residual magnetism is not neutralized, partial tape erasure is possible during succeeding tape operations.

In order to prevent this unwanted magnetism, the transport performs a degaussing operation at the conclusion of a write function. See figure 4-21. When the write enable (-WR EN) signal goes from a logic low to a logic high, the microprocessor refreshes the write reference (+WR REF) signal to its maximum voltage, charging C18 refresh capacitor. The microprocessor then stops the refresh cycle, allowing the refresh degauss capacitor to discharge. The write current operational amplifiers see a decreasing positive voltage, the affect of which results in an exponential decay of write current. At the same time that the capacitor is allowed to discharge, the write data input lines are switched at a 10 KHz rate. As the write current is switched at 10 KHz, the exponential decay of the current waveform causes any residual magnetism to be neutralized.

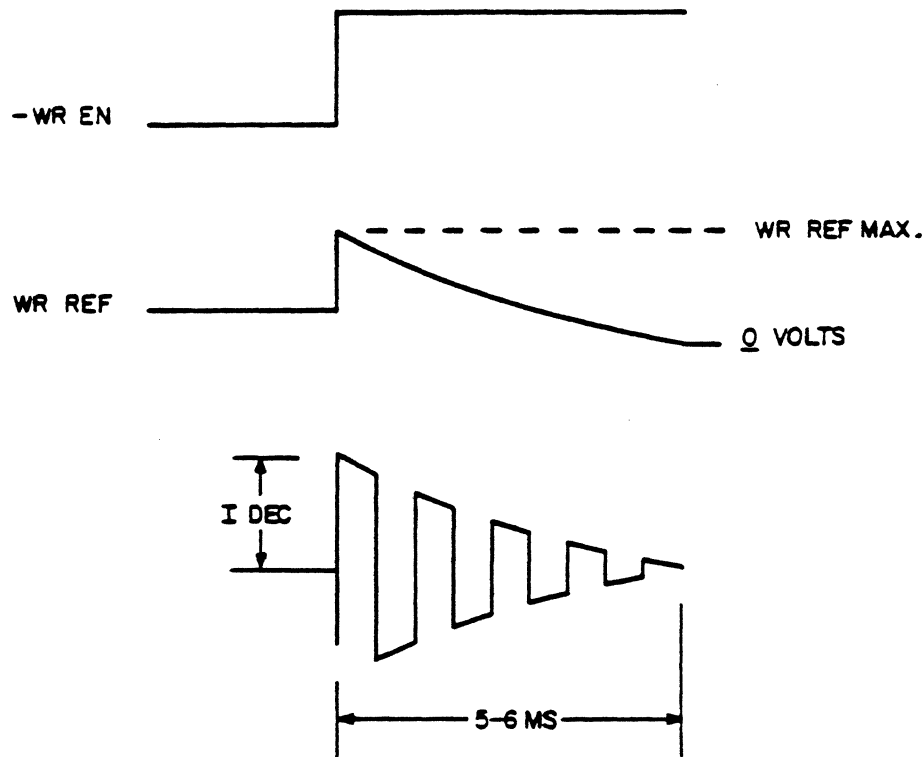

Figure 4-21. Degaussing Waveform

## READ AMPLIFIER PWA

A read operation is initiated from the controller during any read or write operation. As tape motion is initiated and tape passes across the read head coils, recorded data on the tape induces a voltage in the head coils. This voltage has to be amplified, and circuit selection made, depending on tape speed and recording mode. The entire read chain is responsible for detection of data, amplification of the low amplitude readback signal, and conversion of the analog signal to a digital TTL logic level for use in the formatter and interface portions of the transport. See figure 4-22.

## READ RECOVERY

As data is detected when tape passes the read head, the induced voltage is differentially coupled to a preamplifier to help reduce common mode noise while amplifying the relatively weak read head signal. The amplification factor at this stage is determined by a programmable gain control circuit that is selected by the microprocessor. The amplified signal is then differentially coupled to a second stage for an additional gain of 20.

The third stage in the read chain is a selectable gain, low pass filter providing roll-off of the high and low end of the read signal. Gain of this stage is dependent on the speed and recording mode that the microprocessor selects.

The fourth stage is both a programmable bandpass filter and differentiator. The bandpass filter, with a frequency selected by the speed and recording mode, sets the upper and lower frequency limits of the input signal.

The fourth stage output is connected to both the zero cross detector and envelope threshold level detector. The threshold circuit compares the single-ended output voltage of the fourth stage with a clip level voltage labeled TH1 and TH2. The clip levels are a percentage of the nominal input voltage and are predetermined by the microprocessor, depending on the type of operation being performed. The threshold detector turns on with a delay of approximately 6.8 microseconds in high speed (75 ips) or 27 microseconds in low speed (25 ips), and turns off with a delay of approximately 12.3 microseconds in high speed or 48 microseconds in low speed. Envelope detection takes place only when the processed read signal overcomes the microprocessor-controlled clip levels. This microprocessor-controlled level can be between 0 and 100% of the read signal.

Output from the envelope detection/clip circuits is ANDed with the output of the zero cross detector to enable the transfer of read data from the read amplifier PWA.

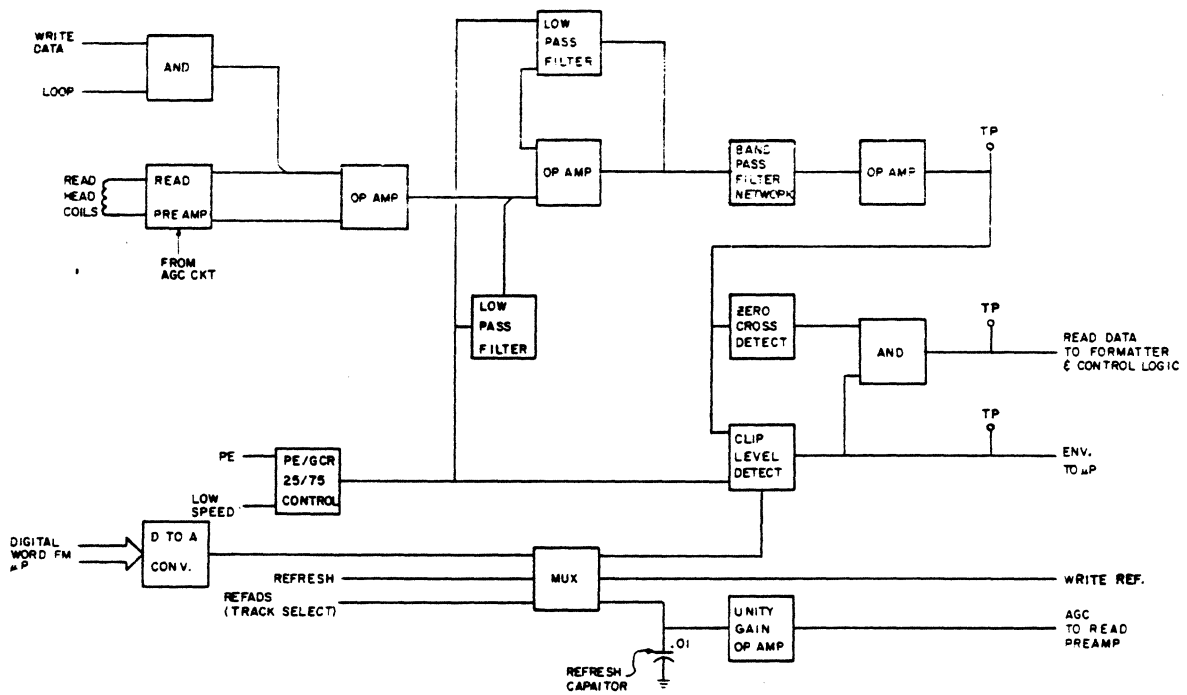

Figure 4-22. Read Amplifier Block Diagram

## Automatic Gain Control (AGC)

AGC is designed to replace the potentiometer formerly used to determine the readback amplitude of recorded data.

In PE mode, the circuit is activated through the use of field service diagnostics when the PWA or magnetic head is replaced, or if reported errors are such that the field service determines the need to activate AGC. In GCR mode, the circuit is activated every time tape is read from the BOT marker. When the formatter recognizes the GCR ID burst, the AGC circuit is enabled so that the first stage amplifier gains can be set during the ARA burst.

The AGC lines during normal operation are constant, and provide the appropriate input to the first stage amplifiers to set a nominal output of 2.0 volts peak-to-peak at the analog test point. This output voltage may vary slightly due to magnetic head wear or the type of magnetic tape being used.

Operation of the AGC circuit during the off-line field service diagnostics in PE or during the ARA burst in GCR is as follows: The readback signals are sampled through the ENV outputs of the read chain, with an AGC clip level set at 95%. The test is initiated with a binary bit count of 128 (80 Hex) applied to the digital-to-analog converter (DAC). The output voltage of the DAC is then applied to an analog multiplexer. The microprocessor provides the input gating to the multiplexer so that the voltage conversion of the 128 count is applied to each of the nine read circuits on an individual basis.

Using one read channel for discussion purposes, AGC voltages are set up as follows: The voltage equivalent of the binary 128 count is gated through the analog multiplexer and charges a 0.01 uF capacitor to the value whereby, the read amplifiers have a mid-point gain. As data is read from tape, the output of the read amplifier is sampled by the envelope comparator. If the ENV signal is low, the microprocessor uses a successive approximation method of the binary count to the DAC so that an optimum AGC voltage is applied to the read amplifiers. If the ENV signal is low or inactive, the microprocessor lowers the binary count by half (64) to the DAC. The DAC then outputs a voltage equivalent to the 64 count to the AGC capacitors. The read amplifier gain is increased and the ENV signal is again sampled by the microprocessor. The microprocessor adjusts the binary count either up or down by half of the previous count, depending on whether the ENV signal is active or inactive.

This method of successive approximation is continued until the microprocessor determines, via the ENV signal, that the read gain is optimum. In this manner, the count "zeros in" on the point at which the ENV signal is active except for extraneous pulses going inactive. At this point, it can be assumed that, if the ENV signal is mostly active at the 95% AGC clip level, then when the normal clip level is used, then ENV signal will be a solid active level.

The binary count for each read channel is stored in memory. During normal on-line operation, the microprocessor will access memory every 11 milliseconds, and the AGC voltage charges the 0.01 uF refresher capacitor to maintain a constant gain of the first stage read amplifier.

#### LOOP DATA

The LOOP signal is used to exercise the read/write circuits without tape motion. In the read circuits, the signal LOOP turns on a transistor and FET circuit so that the read chain is effectively isolated from the read preamplifier and magnetic head. This isolation allows the loop write data to be connected to the read chain for diagnostic purposes.

## FORMATTER PWAs

The formatter PWAs, comprising the formatter read and formatter write PWAs, are located functionally between the interface PWA and the read/write/servo control logic set. The formatter PWAs perform the following operations:

1. Translate I/O commands sent from the host system for the tape drive.
2. Encode and decode data to and from PE format or GCR format.
3. In write operations, generate tape control and identification marks. In read operations, delete tape control and identification marks.
4. Generate and monitor data error detection codes and perform error correction "on-the-fly".
5. Monitor and report Hard Error (HER) conditions.
6. Control reconstruct times when in streaming operation.

## I/O COMMAND TRANSLATION

The formatter PWAs serve as a link in the I/O chain by accepting commands sent by the host system, and translating these commands into tape motion and data transfer instructions for the tape drive (see figure 4-23).

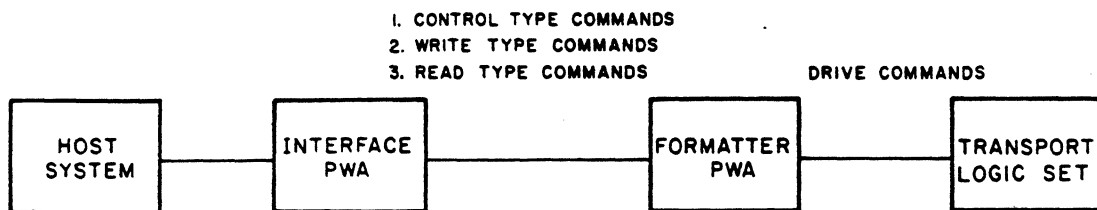

1  
CONTROL TYPE COMMANDS

- Sense
- Rewind Tape
- Unload Tape
- Put Drive Online
- Select Low Speed
- Select High Speed
- Select Auto Speed
- Select PE Mode
- Select GCR Mode
- Diagnostic Commands

2  
WRITE TYPE COMMANDS

- Write a Record
- Write a Record with Long Gap
- Write a File Mark
- Write a File Mark with Long Gap
- Erase 3 Inches
- Controlled Erase
- Data Security Erase

3  
READ TYPE COMMANDS

- Read a Record Forward
- Read a Record Reverse
- Read a File Forward
- Read a File Reverse
- Space a Record
- Backspace a Record
- Controlled Backspace a Record
- Space a File
- Backspace a File

DRIVE COMMANDS

- Write
- Data Security Erase
- Read Forward
- Read Reverse
- Sense Byte n
- Rewind
- Unload
- Online
- Change Speed
- Select PE Mode
- Select GCR Mode
- Select Start/Stop Mode
- Select Streaming Mode
- Clear Interrupt
- Diagnostic Commands

Figure 4-23. I/O Command Translation

## DATA CONVERSION

The formatter PWAs are responsible for encoding and decoding data to and from PE format and GCR format.

### PE Data Conversion

In PE format, the data block must begin with a preamble and end with a postamble. In the data format sent by the host system, flux transitions in the middle of a cell define the 1's and 0's. A positive pulse (flux transition) indicates a 1; a negative pulse indicates a 0. A cell is the time required to transfer one data bit (see figure 4-24). In order to denote two contiguous 1's or 0's, a phase pulse must occur at the junction of the two cells. A positive phase pulse occurs at the junction when both cells contain 0; a negative phase pulse occurs when both cells contain 1. The absence of a phase pulse at a cell junction indicates that the cells contain opposite values.

### GCR Data Conversion

GCR (Group Coded Recording) is a coding scheme rather than a recording mode. The GCR scheme translates an 8-byte data group, comprising two 4-byte subgroups, into a 10-byte recording group, comprising two 5-byte subgroups. The first data subgroup converted contains 4 data bytes; the second data subgroup converted contains 3 data bytes and an error correcting code (ECC) (see figure 4-25). Note that in the 5-bit GCR conversion of the 4 data bits, there are no more than two contiguous 0's and no more than a single 0 at either end of the 5-bit string (see figure 4-26). This scheme yields a more narrow band-width and better synchronization capability.

After conversion to the GCR code, the data is recorded on tape using the NRZI method. In the NRZI method, a change in the direction of flux indicates a 1 bit (see figure 4-27).

## TAPE CONTROL AND IDENTIFIER MARK GENERATION AND DELETION

For both PE and GCR modes, the formatter PWAs generate the tape control and identifier marks in write operation, and strip off these marks during the read operation. The following paragraphs detail the content and location of these marks.



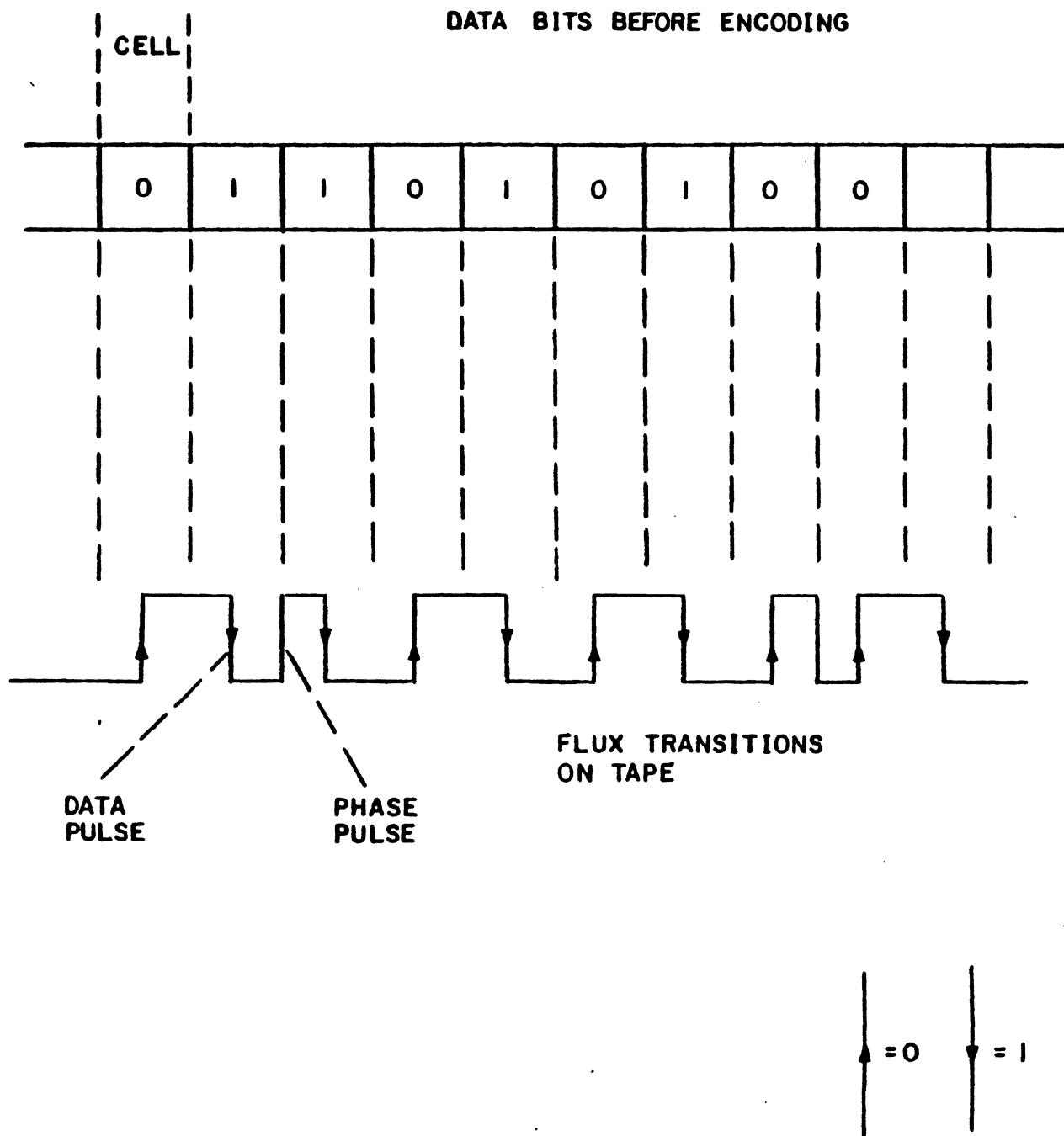

Figure 4-24. Phase Encoding

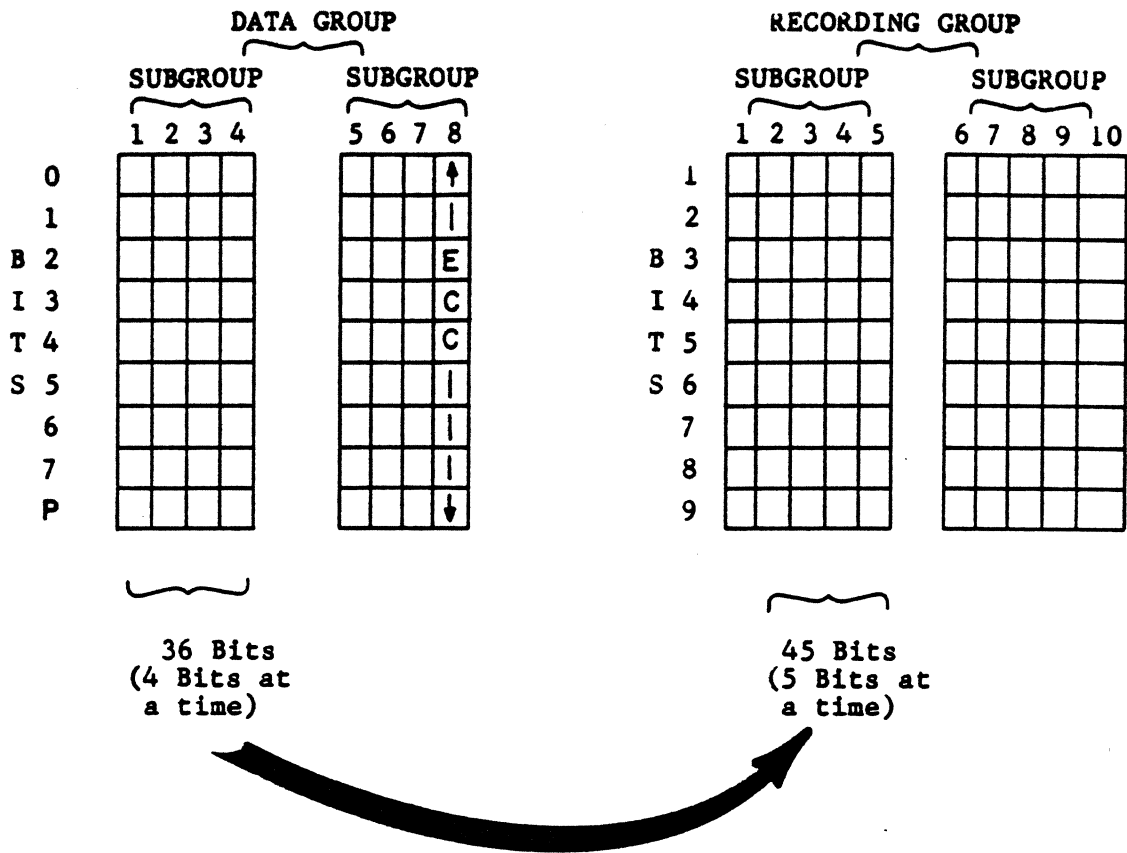

Figure 4-25. GCR Conversion

4 Bits Data Value	⇒	GCR Value
0 0 0 0		1 1 0 0 1
0 0 0 1		1 1 0 1 1
0 0 1 0		1 0 0 1 0
0 0 1 1		1 0 0 1 1
0 1 0 0		1 1 1 0 1
0 1 0 1		1 0 1 0 1
0 1 1 0		1 0 1 1 0
0 1 1 1		1 0 1 1 1
1 0 0 0		1 1 0 1 0
1 0 0 1		0 1 0 0 1
1 0 1 0		0 1 0 1 0
1 0 1 1		0 1 0 1 1
1 1 0 0		1 1 1 1 0
1 1 0 1		0 1 1 0 1
1 1 1 0		0 1 1 1 0
1 1 1 1		0 1 1 1 1

Figure 4-26. GCR Translation Values

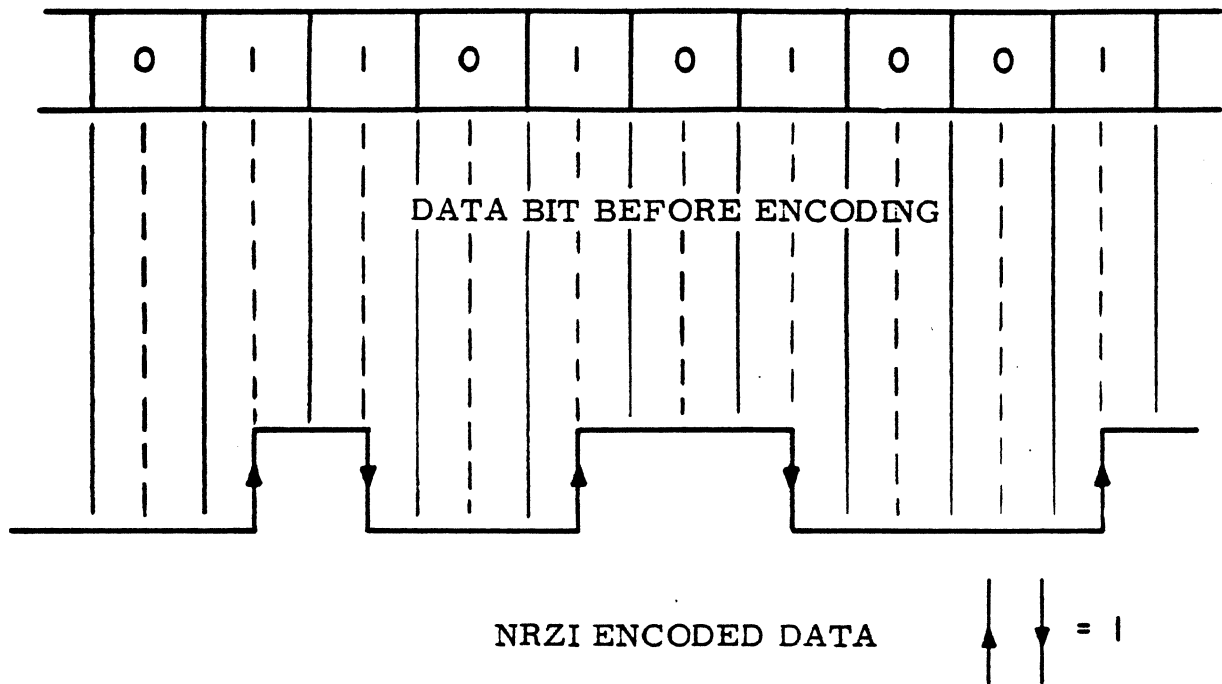

Figure 4-27. NRZI Encoding

#### PE Data Block Format

The PE tape (see figure 4-28) begins with the PE density identification burst consisting of a series of alternate 1s and 0s in track 4. The inter-block gap, which follows the density identification burst, is nominally 0.6, but may be increased up to 1.2 inches, depending on data availability.

The PE data block begins with a preamble (40 tracks with all 0s followed by 1 track of all 1s) and ends with a postamble (1 track of all 1s followed by 40 track of all 0s).

#### GCR Data Block Format

The GCR data format requires not only preamble and postamble patterns, but also data conversion into groups, for each of which an error correcting code (ECC) clearance is generated. Also, cyclic redundancy checks (CRCs) and auxiliary cyclic redundancy checks (ACRCs) are added to the data to facilitate detection and correction of errors. Resynchronizing bursts are added for transfers over 1106 bytes to enable the read detection logic to resynchronize (see figure 4-29).

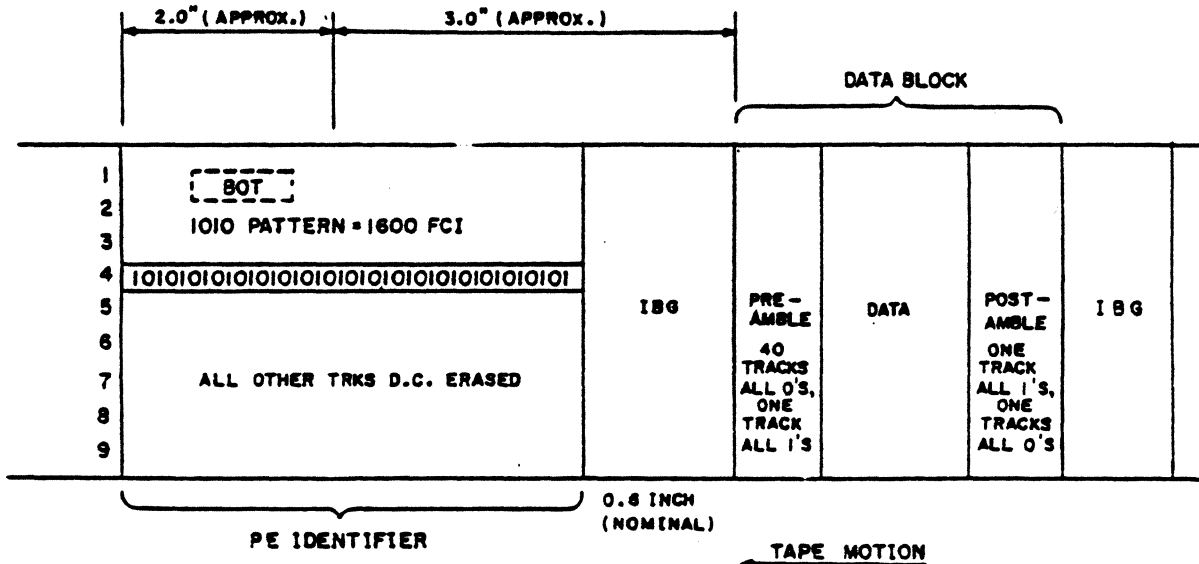

Figure 4-28. PE Format

The components of the GCR tape format are described below in the sequence in which they are written on the tape.

- o Density Identification
  - A burst in the PE frequency range on track 6. All other tracks are erased.
- o Interblock Gap (IBG)
  - A dc erased section of tape separating blocks of information. Nominally 0.3 inch; may be varied up to 0.6 inch.

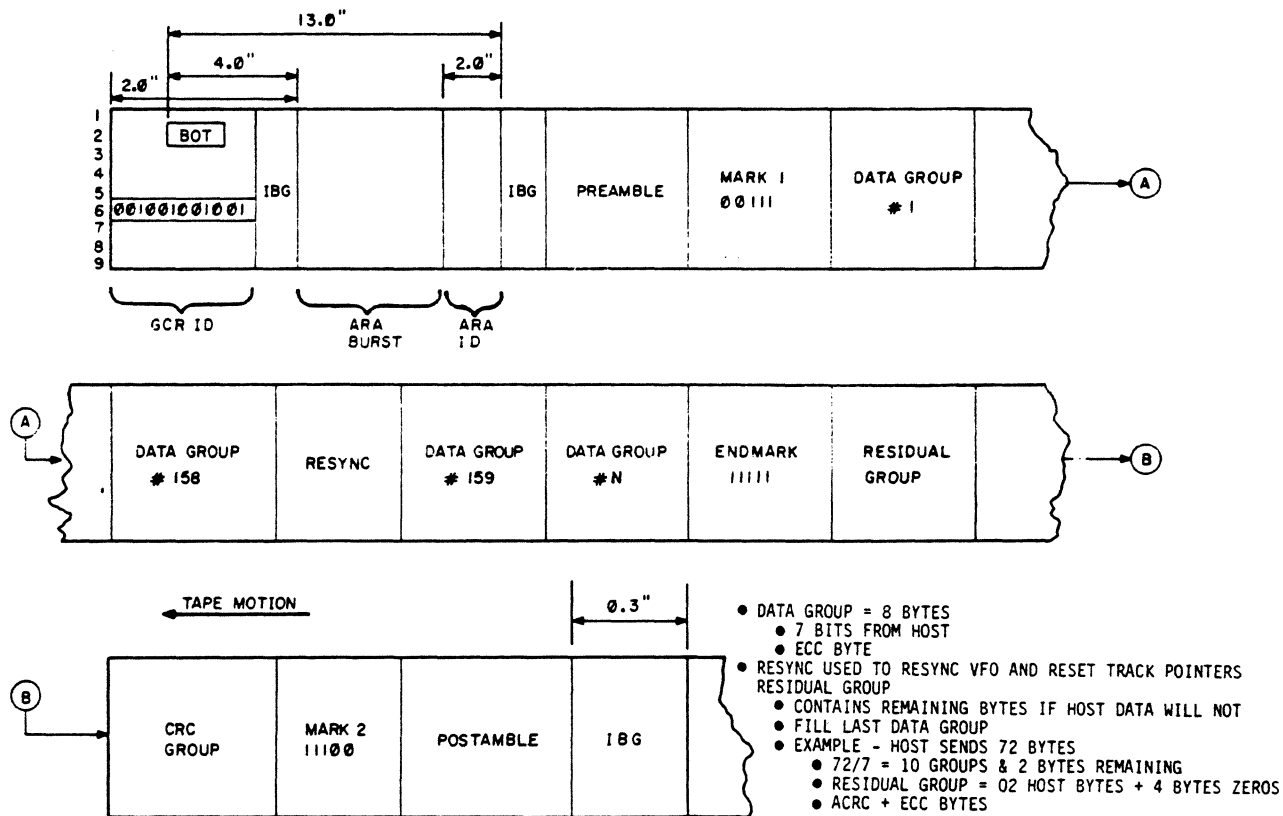

Figure 4-29. GCR Tape Format

- o ARA (Automatic Read Amplifier) Burst

A string of all 1's in all tracks placed on the tape for the purpose of setting up the read amplifiers.

- o ARA ID (Automatic Read Amplifier Identification)

A special control at the send of the ARA. When reading backwards, the ARA ID denotes the appearance of the ARA burst.

- o PREAMBLE (see figure 4-30A)

A group of signals recorded at the beginning of a block for circuit synchronization. The preamble contains 16 subgroups, the first of which is the terminator (TERM) control subgroup. The terminator subgroup is the first (and last) subgroup of a record. The next subgroup is the secondary (SEC) control subgroup which is the second (and next to last) subgroup of a record. Next, 14 synchronization subgroups are written which complete the preamble.

- o MARK 1

A control signal which separates control subgroups from data. When the tape is moving forward, it denotes the beginning of data.

- o Data Group

From 1 to 158 data groups may be written. Each data group comprises 2 subgroups. The first contains 4 data bytes. The second subgroup contains 3 data bytes and 1 error correcting code (ECC) byte. Note that the tape format is shown before the 4/5 conversion takes place.

- o RESYNC (See figure 4-30B)

The RESYNC burst is written following the 158th data group in order to resynchronize the circuits and to clear dead-track and phase error pointers. The first element of the RESYNC burst is MARK 2, a signal which separates data from control subgroups. Next, two sync subgroups are written, followed by MARK 1, to separate the control signals from the data. After RESYNC, another series of data groups may be written.

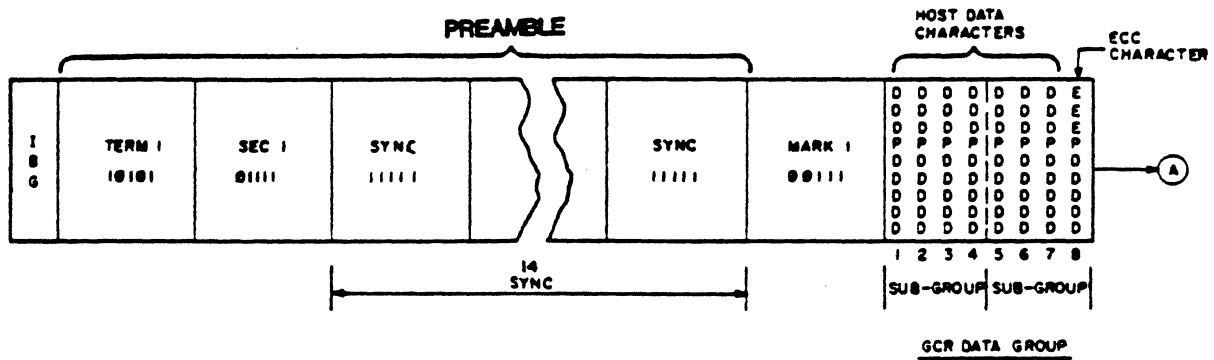

Figure 4-30A. Detail of GCR Tape Format

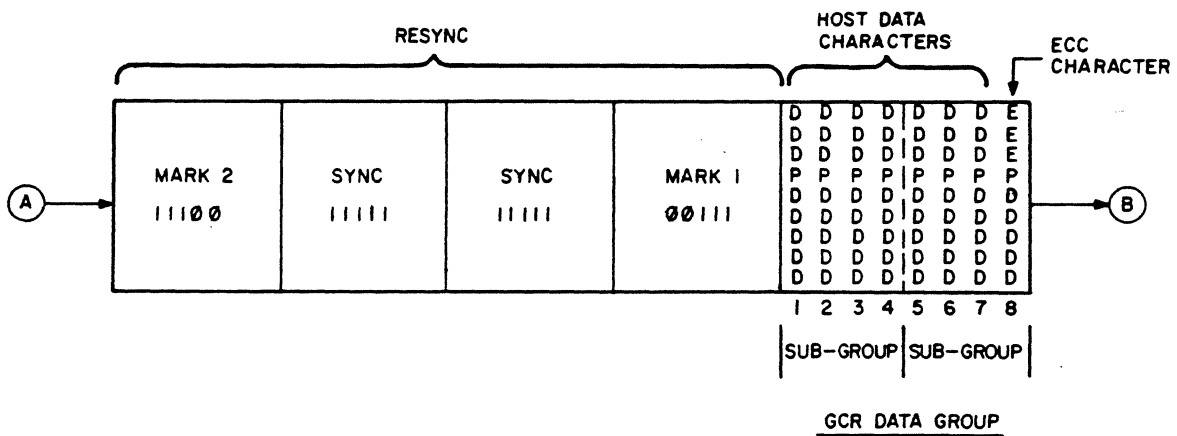

Figure 4-30B. Detail of GCR Tape Format

- o END MARK (see figure 4-30C)

A control signal separating the last full data group from the residual group.

- o Residual Group (see figure 4-30C)

Contains the remaining data characters from the host, and pad characters if needed, to fill the first six positions in the group. The 7th character is the auxiliary cyclic redundancy check (ACRC); the 8th character is the error correcting code (ECC) character.

- o Cyclic Redundancy Check (CRC) Group (see figure 4-30C)

The first character is either a pad character or the CRC character. Positions 2 through 6 are occupied by the CRC character. The 7th position is occupied by the residual character and the 8th position is occupied by the ECC character.

- o MARK 2 (see figure 4-30C)

A control signal separating data from control subgroups. When tape is moving forward, it marks the beginning of other control signals.

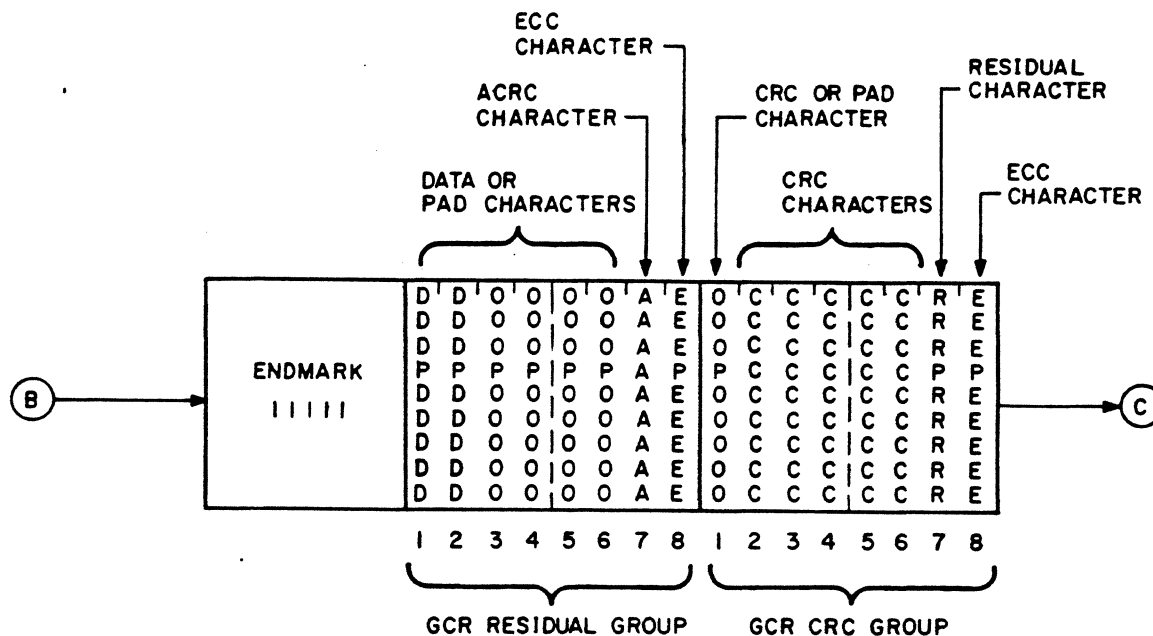

Figure 4-30C. Detail of GCR Tape Format



o POSTAMBLE (see figure 4-30D)

A group of control signals at the end of the data block. There are 16 subgroups, the first 14 of which are synchronizing subgroups for the electronic synchronization of the circuits. The next to last subgroup is the secondary (SEC) control subgroup and the last is the terminator (TERM) control subgroup.

Under control of the formatter logic, the preamble, postamble and resynchronizing codes are generated in the correct sequence, and the data is manipulated to produce a correctly coded data block. After the preamble is generated, data from the interface PWA is clocked through the formatter input circuitry to the 4/5 converter where 4 bytes are converted to 5 bytes. After every seventh byte, an ECC character is generated by the logic from the incoming data and sent to the 4/5 converter. At the end of data transfer, with the LAST WORD signal from the interface PWA, padding characters of zero value are added to the final group to make a complete group. Cyclic redundancy check (CRC) and auxiliary cyclic check (ACRC) characters are generated from the incoming data and inserted in the data block in the appropriate locations. At the termination of data transfer, a postamble is generated and placed at the end of the data block (see figures 4-30A, 4-30B, 4-30C, and 4-30D).

During a read operation, the control and error detection codes are removed in the formatter PWAs before the data is transferred to the host.

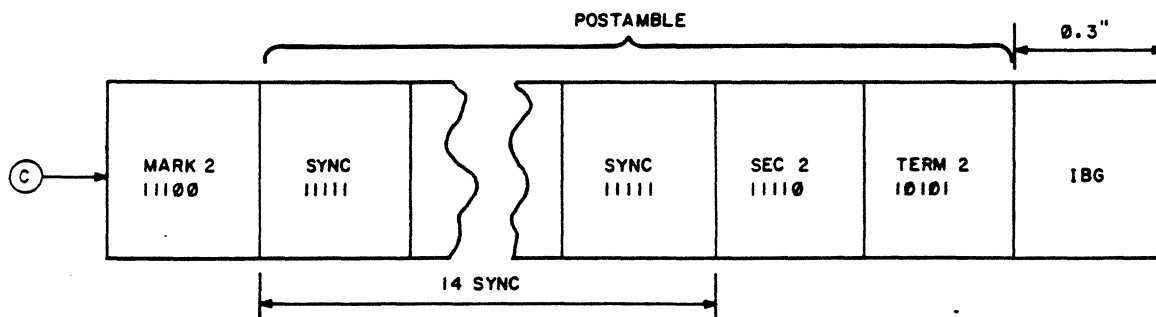

Figure 4-30D. Detail of GCR Tape Format

## ERROR DETECTION AND CORRECTION

When operating in PE mode, single track, "on-the-fly" parity error detection and correction is performed. In GCR mode, single and 2-track, "on-the-fly" error detection and correction are performed by means of cyclic codes.

The read detection circuit performs best when the incoming signal level from the track is between 300 mV and 900 mV; the optimum level is 500 mV. When the signal level drops below a specified value, a warning latch is set for that track to denote the presence of a marginal signal. The latch remains set until resynchronization or the end of the data block. Setting the latch is called "dead tracking".

In PE mode, when a parity error is found in a byte, the warning latches for all 9 tracks are checked to see if any track is "dead tracked". If a track is, it is assumed that the bit in the dead track is in error, and that bit is reversed before the byte is sent to the interface PWA.

For proper data detection in PE mode, the flux reversal denoting a bit should occur approximately in the middle of the bit cell. If the flux reversal takes place outside a window of  $\pm 25\%$  of center (see figure 4-31), a phase error signal is generated to indicate that the data detected on that track may be in error. In GCR mode, the limit of the window in a write operation is  $\pm 37.5\%$  of center; in the read operation, the window limit is  $\pm 43.75\%$  of center (see figure 4-32). The phase error indication lasts only as long as the time required for the bit cell to traverse the read head. The data correction is similar to that described in dead tracking - when a parity error is found, the phase error field is scanned to see if a track is reported in error; if so, the bit in that track is reversed.

The limitations to the PE methods are that, if more than 1 track is dead tracked, or if a dead track error and phase error occur in the same byte, an unresolved bit error condition exists. Also, parity checking does not detect an error if both bits are wrong. Or, if only one bit is wrong, there is no way to determine which of the two tracks is in error.

The lack of perfect perpendicularity between the tape track and the read/write heads is known as "skew". This condition causes the bits comprising a byte to be read at slightly different times.

Skew compensation is implemented by transferring read data from the tape over nine separate detection circuits (one for each track). The detected bits are gated independently into a skew buffer. When the skew buffer has received all of the bits in the byte, the byte is gated out as a unit.

In GCR mode, three check characters based on cyclic codes are used in error detection and reporting. These check characters are:

- o Error and Correcting Code (ECC) Character
- o Cyclic Redundancy Check Character (CRC)
- o Auxiliary Cyclic Redundancy Check Character (AUX CRC)

The ECC character, which contains 8 bits, is generated as the 8th byte of a data group (see figure 4-30). By means of the ECC character, single track errors can be detected and corrected "on-the-fly" without the need of track pointers. The ECC character also detects double track errors, but requires the aid of dead track pointers and phase error pointers to correct the errors. These pointers use the same methods to identify the tracks as in PE error detection.

NOTE: Phase error is generated when no data transition within  $\pm 25\%$  window.

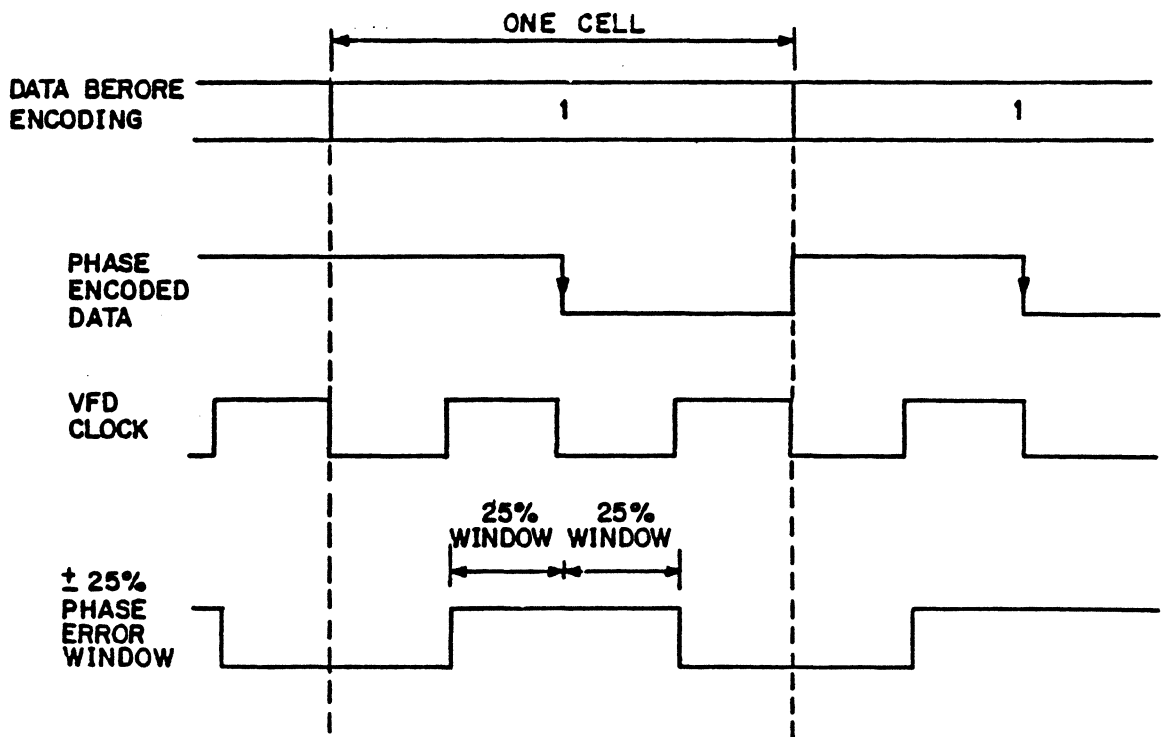

Figure 4-31. Phase Error Window - PE Mode

The CRC character and AUX CRC character are generated from the data structure and written into it so that the validity of the data can be checked after it is read. These characters indicate only the occurrence of one or more errors; they do not identify the location of the error(s), nor are the error(s) corrected. However, the host system is informed of the error occurrence so that the host can initiate its retry procedure.

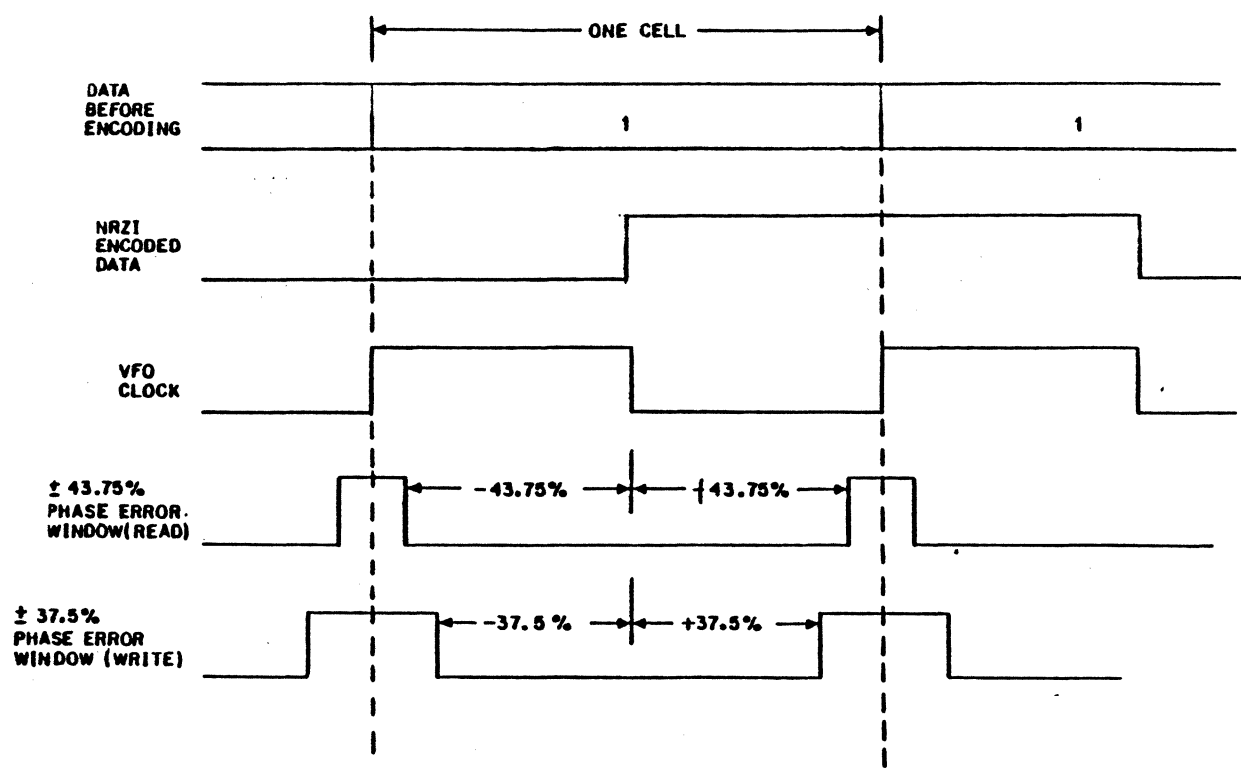

Figure 4-32. Phase Error Window - GCR Mode

## INTERFACE PWA

Detailed descriptions of the interface PWAs for the STU are contained in the following manuals:

<u>Pub. No.</u>	<u>Title</u>
49763010	Hardware Reference/Maintenance Manual, Vol. II, Appendix A, OEM Interface
49763020	Hardware Reference/Maintenance Manual, Vol. II, Appendix B, Buffered Pertec Interface

Additional interface appendices will be published as the need arises.

## SYSTEM AND TIMING CONSIDERATIONS

### MOTION CHARACTERISTICS

The STU has two operating speeds: 25 ips and 75 ips. Selection of either speed is made at the STU interface, with 25 ips being the default speed. Following a rewind operation, the STU automatically reverts to 25 ips.

In the following discussions, read operations represent all read-type operations such as READ, SPACE, and SEARCH. Similarly, write operations represent all write-type operations such as WRITE DATA, ERASE, and WRITE FILE MARK.

### START/STOP MODE

In the start/stop mode, STU operation is similar to that of a conventional 1/2 inch tape unit. It accelerates the tape when a command is received, and stops the tape within the IBG. A long IBG of 1.2 inch nominal in PE or 0.6 inch in GCR may be commanded as well as the normal or 0.7 inch nominal IBG in PE or 0.4 inch in GCR.

## Read Operations

After a block has been successfully traversed, the tape is brought to a complete stop to await the next command. The microprocessor delays the subsequent start if the time since the last start is less than 80 ms.

### NOTE

In start/stop mode, tape is stopped between records regardless of reinstruct timing.

## Write Operations

Tape control is the same as described above for the read operation; the 80 ms restriction also applies. The nominal IBG written in this mode is 0.7 inch in PE and 0.4 inch in GCR.

## Other Start/Stop Motion Characteristics

Whenever a change from read to write mode is experienced (forward direction), a "jog" operation is performed in order to position the erase within the IBG. The time to execute the jog operation is nominally 191 milliseconds in PE and (TBD) in GCR. When changing from WRITE to READ REVERSE or REWIND, a forward jog to erase a full gap is inserted by the transport. This insures that there will be no glitch in the initial gap when the write head is turned off. Time required to execute the forward jog is 120 milliseconds in PE and (TBD) in GCR.

## STREAMING MODES (25 ips and 75 ips)

The streaming modes are high performance operating modes designed to accommodate transfers of many contiguous data blocks to or from tape. Unlike the start/stop mode, tape acceleration and deceleration cannot be accomplished within the interblock gap (IBG). In order to efficiently utilize the streaming mode, tape motion must be sustained by commanding successive data operations. This is accomplished by issuing subsequent commands to the STU during the time the STU is traversing the IBG. This command window is referred to as the command reinstruction time interval. Should a follow-up command not be received during the reinstruction interval, a repositioning cycle is required.

(A REVERSE command can be received during the initial down ramp and reverse ramp up, and will be executed without going through the complete repositioning cycle.) By way of illustration, consider this 75 ips case: Assume that the STU is in PE mode and has just completed a write data operation; if the normal IBG length of 0.6 inch is commanded by the system, then the system has 6.0 ms to respond with a subsequent WRITE command in order for streaming mode to be sustained. If the subsequent WRITE command is not received by the end of the reinstruction interval, the STU will reposition itself in anticipation of the next streaming mode command. The repositioning cycle times are defined in table 4-1 for the various modes of operation selected.

There are three sequences of events which generally describe the motion characteristics of the STU in the streaming mode. These sequences are:

- o Case 1 - Command received during reinstruction interval
- o Case 2 - command received during repositioning cycle
- o Case 3 - Command received following repositioning cycle

These three sequences are applicable to both forward and reverse operations and are described on the following pages individually. First, a more general discussion of streaming mode motion characteristics is presented.

(See Figure 4-33) In order for the STU to perform a data operation on Block N + 1 from a stopped position (point E), it must first accelerate and be up to speed at point F as referenced to the read head in the case of a read-type operation, or erase head in the case of a write-type operation. For the case where the STU has just completed a data operation on Block N and a repositioning cycle is required, the STU begins the repositioning cycle at point B and traverses path BCDE. The STU then positions itself at point E in anticipation of the next operation. The STU presumes the next operation to be a streaming mode operation on Block N + 1. A sequence chart is presented in table 4-2 which identifies STU streaming mode motion sequences for combinations of previous and present command issuances. In all cases, the next command is received during the reinstruct time.

Table 4-1. STU OPERATIONAL PERFORMANCE SUMMARY

PARAMETER	UNIT OF MEASURE	
Tape Velocity (Long Term)	inches per second	
a. High Speed		75
b. Low Speed		25
Long Term Speed Variation		3% Maximum (Note 1)
Short Term Speed Variation		5% Maximum (Note 1)
Recording Density	bits per inch	
a. GCR		6250
b. PE		1600
Channel Data Transfer Rate (Average Overblock)	kilobytes per second	
a. GCR		
1. High Speed		469
2. Low Speed		156
b. PE		
1. High Speed		120
2. Low Speed		40
Load Time	seconds	15 Maximum (Note 2)
Access Time (GCR Mode) (Note 14)	milliseconds	
a. High Speed Streaming		
1. Write		150
2. Read		135
b. Low Speed Streaming		
1. Write (After Write)		37
2. Read (After Read)		28
3. Write (After read)		133
c. Low Speed (Start/Stop)		
1. Write		22
2. Read Fixed Short Gap		24
3. Read Fixed Long Gap		34
Tape Tension	ounces	8.0



Table 4-1. STU OPERATIONAL PERFORMANCE SUMMARY (Cont'd)

PARAMETER	UNIT OF MEASURE
Access Time (PE Mode) (Note 14)	milliseconds
a. High Speed	
1. Write	154
2. Read	135
b. Low Speed (Streaming)	
1. Write (After Write)	43
2. Read (After Read)	34
3. Write (After Read)	159
c. Low Speed (Start/Stop) (Note 11)	
1. Write	22
2. Read Fixed Short Gap	24
3. Read Fixed Long Gap	48
Interblock Gap Size	inches
a. Write	
1. PE Mode	
Short Gap (Fixed)	
- Low Speed Streaming (Note 8)	0.6 to 0.7
- Low Speed Start/Stop (Note 8)	0.7
- High Speed	0.6
Short Gap (Variable) (Note 3)	0.6 to 0.9
Long Gap (Fixed)	1.2
Long Gap (Variable) (Note 3)	0.6 to 1.2
2. GCR Mode	
Short Gap (Fixed)	
- High Speed Streaming	0.3
- Low Speed Streaming	0.3 to 0.45
Short Gap (Variable)	0.3 to 0.45
Long Gap (Fixed)	0.6
Long Gap (Variable)	0.3 to 0.6
Start/Stop	0.4
Start/Stop (Fixed Long Gap)	0.6
b. Minimum Read Gap Supported (Notes 9 & 10)	
1. PE Mode	0.5
2. GCR Mode	0.28

Table 4-1. STU OPERATIONAL PERFORMANCE SUMMARY (Cont'd)

PARAMETER	UNIT OF MEASURE					
Positioning Time (Note 5)	milliseconds					
a. High Speed		430				
b. Low Speed Write		130				
c. Low Speed Read		100				
Reposition Time (Note 4)	milliseconds					
a. Low Speed GCR Write		176				
b. Low Speed GCR Read		130				
c. Low Speed PE Write		164				
d. Low Speed PE Read		139				
e. High Speed Write (PE/GCR)		570				
f. High Speed Read (PE/GCR)		540				
Rewind Time For 2400 Foot Tape On 10.5 Inch Reel	minutes	2.75 (Max)				
Start/Stop Times	milliseconds					
a. High Speed Streaming		120				
b. Low Speed Streaming		20				
c. Low Speed Start/Stop (PE)		20				
d. Low Speed Start (GCR)		20				
e. Low Speed Stop (GCR)		60				
Command Reconstruct Times (Notes 6, 7, & 13)						
	<u>Read</u>		<u>Fixed</u>	<u>Vari-</u>	<u>Fixed</u>	<u>Vari-</u>
	(MIN)	(MAX)	<u>Long</u>	<u>able</u>	<u>Short</u>	<u>able</u>
			WRITE	<u>Long</u>	WRITE	<u>Short</u>
				WRITE	WRITE	WRITE
GCR						
75 ips	3.5ms	7.5ms	5.5ms	5.5ms	1.5ms	3.5ms
25 ips	11.5ms	23.5ms	17.5ms	17.5ms	9.5ms (.4" gap)	11.5ms
GCR Start/ Stop	0.0ms		7.5ms	0.0ms	0.0ms	0.0ms
PE						
75 ips	7.5ms	15.5ms	13.5ms	13.5ms	5.5ms	9.5ms
25 ips	23.0ms	47.5ms	41.5ms	41.5ms	21.5ms (.7" gap)	29.5ms
PE Start/ Stop	0.0ms		19.5ms	0.0ms	0.0ms	0.0ms

Table 4-1. STU OPERATIONAL PERFORMANCE SUMMARY (Cont'd)

---

- Note 1: Meets both steady-state and short term velocity tolerances as defined by ANSI X3.39-1973 for 1600 CPI phase encoded recording and ANSI X3.54-1976 for 6250 CPI GCR encoded recording.
- Note 2: The BOT marker is assumed to be on the file reel side of EOT/BOT sensor and placed on tape leader in accordance with ANSI X3.39-1973.
- Note 3: The STU streaming mode write operation has optional record gaps selected on a printed circuit board. In PE mode, the following applies. In the short gap mode the record gap will either be fixed at 0.6 inch or variable 0.6 to 0.9 inch. In the long gap mode the record gap will be fixed at 1.2 inches or variable 0.6 to 1.2 inches. In GCR mode, the following applies. In the short gap mode, the record gap will be fixed at 0.3 inch or variable 0.3 to 0.45 inch. In the long gap mode, the record gap will be fixed at 0.6 inch or variable 0.3 to 0.6 inch. The STU will be shipped with the settings in the variable modes.
- Note 4: This is the total time required for accessing first byte of data for a command received immediately after command reinstruct time.
- Note 5: This is the total time required to recover from a command over-run and return to stopped condition to await next operation.
- Note 6: This is the total elapsed time from completion of a command execution to the latest point in inter-record gap, at which the STU can accept another command without a recovery cycle.
- Note 7: The STU in high speed streaming mode has optional record gap lengths. In PE mode, the reinstruct times for a Write reflect a 0.6 inch normal gap, or a 0.9 inch variable gap, or a 1.2 inch variable or fixed long gap. In GCR mode, the reinstruct times for a Write reflect a 0.3 inch normal gap or a 0.45 inch variable gap, or a 0.6 inch variable or fixed long gap. During a Read, the reinstruct times reflect the long gap. If a block is detected before the command is received, the STU will Reposition. If the command is received before the next block is detected, the STU will read the next record without Reposition.

Table 4-1. STU OPERATIONAL PERFORMANCE SUMMARY (Cont'd)

---

- Note 8: The STU automatically switches from low speed streaming mode to low speed start/stop mode when the host system cannot maintain the unit effectively streaming. Since the write gap in start/stop mode is nominally 0.7 inch, the unit will automatically extend IBG to 0.7 inch in streaming mode so as to avoid unnecessary throughput degradation. To keep the unit streaming, the system must reinstruct within 21.5 ms (0.7 inch gap) and, if reinstruct occurs within 17.5 ms, a 0.6 inch gap will be written; between 18 ms and 22 ms gaps greater than 0.6 inches and less than 0.7 inch will be written (see section 8.4).
- Note 9: Unit will read minimum ANSI gaps in all modes.
- Note 10: In streaming modes, the unit will reposition if no reinstruct is received before the next block is encountered or, if the tape has moved 1.2 inches in PE mode or 0.6 inch in GCR mode (this is independent of unit gap selection).
- Note 11: If the previous Read or Write command occurred less than 80 ms prior to new command, this time will be increased by the difference between 80 ms and the actual time since the previous Read or Write.
- Note 12: In PE start/stop mode, the tape will be brought to a full stop after each record regardless of the reinstruct period.
- Note 13: While writing a long gap, the tape will be brought to a full stop if a command of the same type is not received during the reinstruct period.
- Note 14: The time from a stopped state to the transfer of the first byte of data to or from the tape.
-

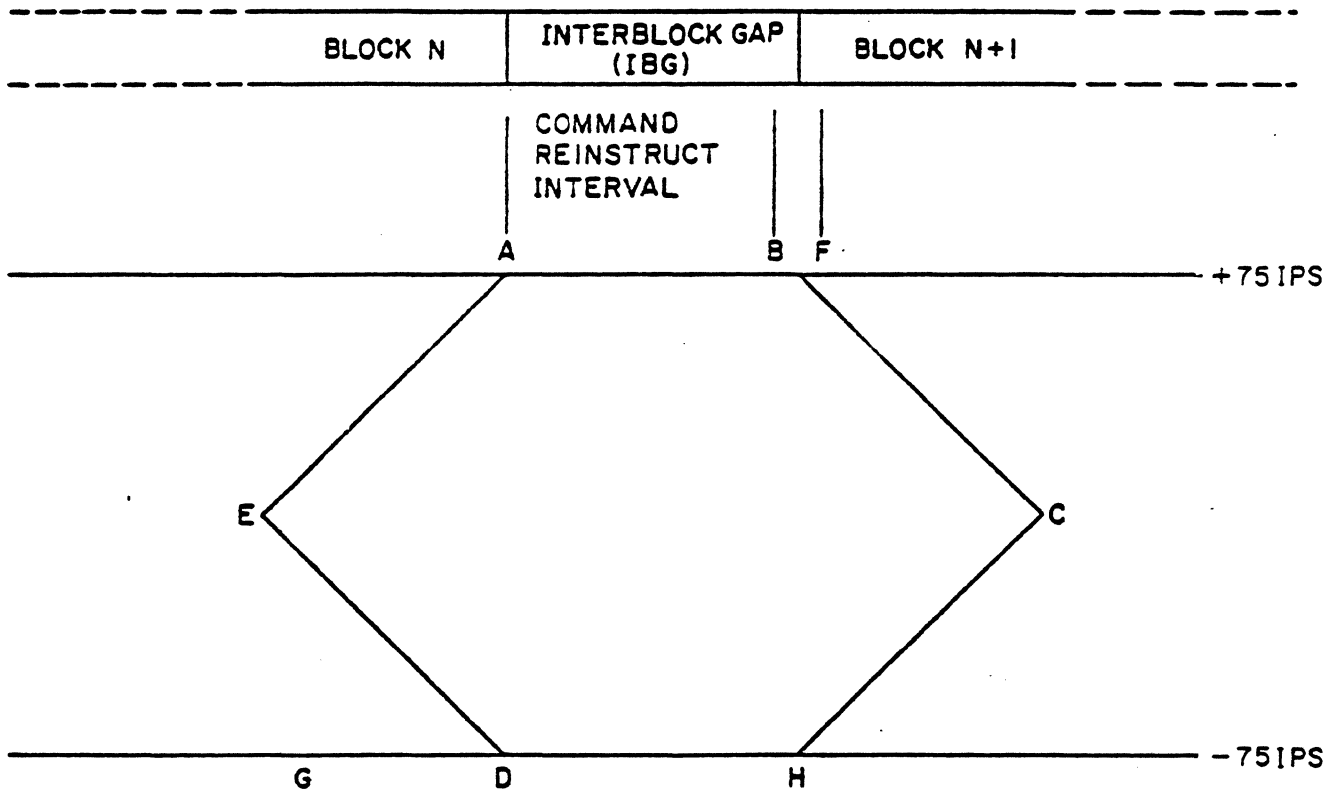

Figure 4-33. Streaming Mode Velocity Diagram

Table 4-2. STREAMING MODE MOTION SEQUENCE CHART

PREVIOUS COMMAND	NEXT COMMAND		
	FORWARD READ-TYPE	REVERSE READ-TYPE	WRITE-TYPE
Forward Read-Type	Path ABF	Paths ABC, CHDG	Path ABCDEF
Reverse Read-Type	Paths HDE, EABF	Path HDG	Paths HDE, EABF
Write-Type	Not Recommended	Paths ABC, CHDG	Path ABF

Case 1 (Non-Stop)

Command Received During Reinstruction Interval - A command is received sometime during the command restruct period following the data operation on Block N. Note that the velocity profile at the bottom of figure 4-34 indicates that full velocity is maintained without interruption through the processing of Block N and N + 1 (refer to figure 4-34).

Case 2 (Momentary Stop)

Command Received During Repositioning Cycle - A command is not received during the Command Restruct period, but rather is received during the Repositioning Cycle. The diagram illustrates, in the distance domain, the sequence of events with respect to the STU motion and the command transfer (refer to figure 4-36).

CASE 1 - NON-STOP

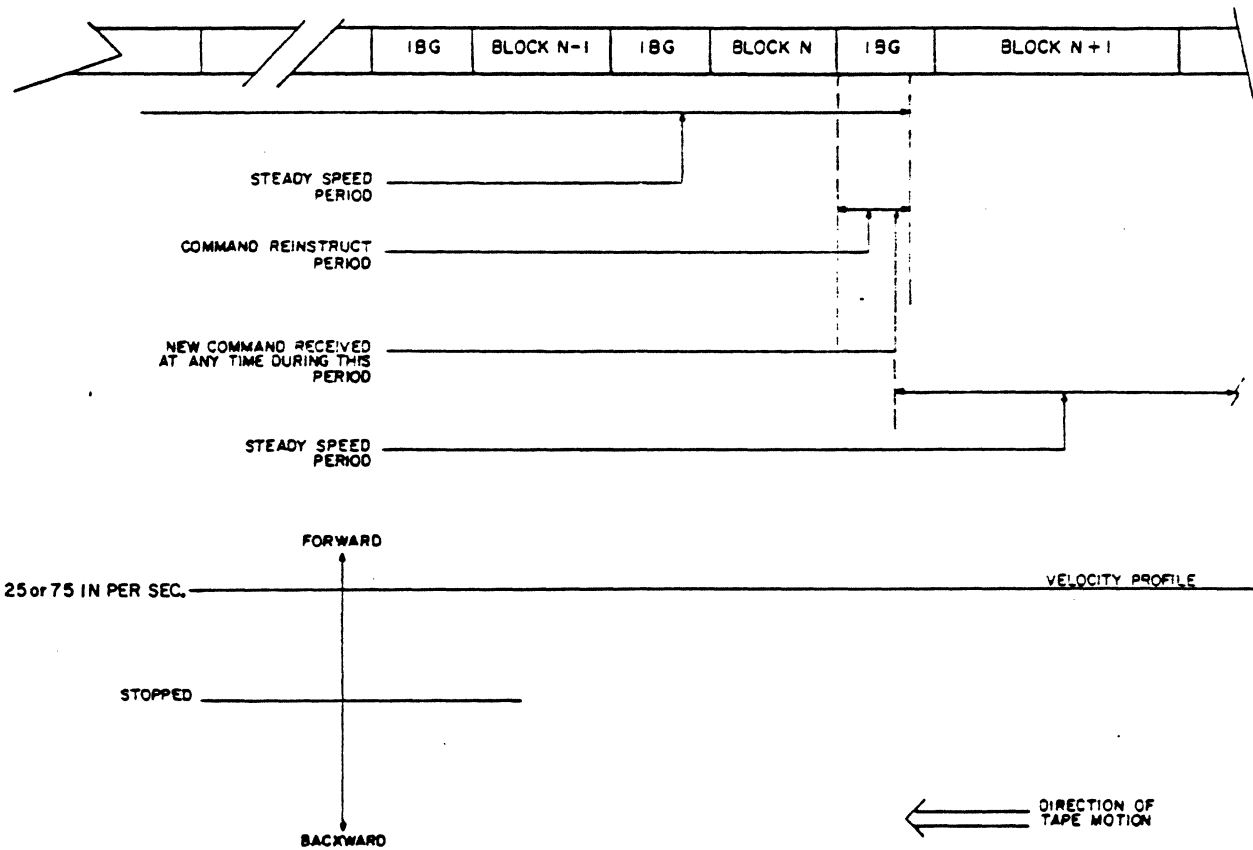

Figure 4-34. Case 1 - Tape Motion Control

The velocity profile illustrates, in the time domain, tape velocity characteristics. Looking at figure 4-36, it can be seen that the tape stops only momentarily to change direction. The velocity profile identifies the time sequence of events. The correspondence between the time and distance portrayals in sequence is as follows:

<u>EVENT</u>	<u>Velocity Profile Position</u>
Steady Speed Period	Up to Point A
Forward Motion Deceleration	A-B
Tape Motion Stopped Momentarily	B
Reverse Motion Acceleration	B-C
Full Speed Reverse Motion	C-D
Reverse Motion Deceleration	D-E
Tape Motion Stopped Momentarily	E
Forward Motion Acceleration	E-F
Steady Speed Forward Through Data Block N + 1	Point F and On

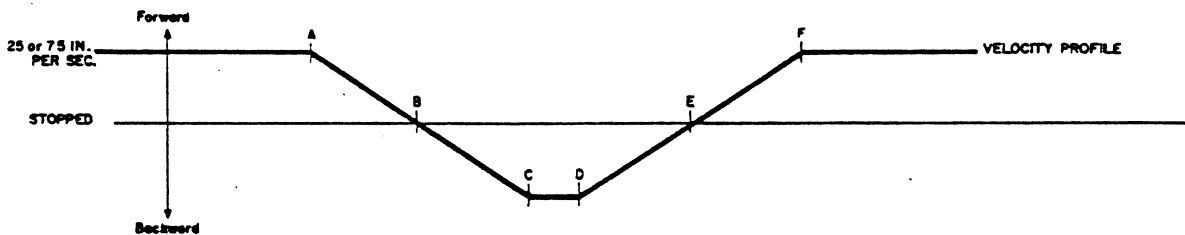

Figure 4-35. Case 2 - Velocity Profile



**TAPE MOTION CONTROL**  
**STREAMING MODE - 75 INCHES/SEC. ( 25 INCHES /SEC.**

**CASE II - START/STOP (CONTINUOUS MOTION WITH MOMENTARY STOPS)**

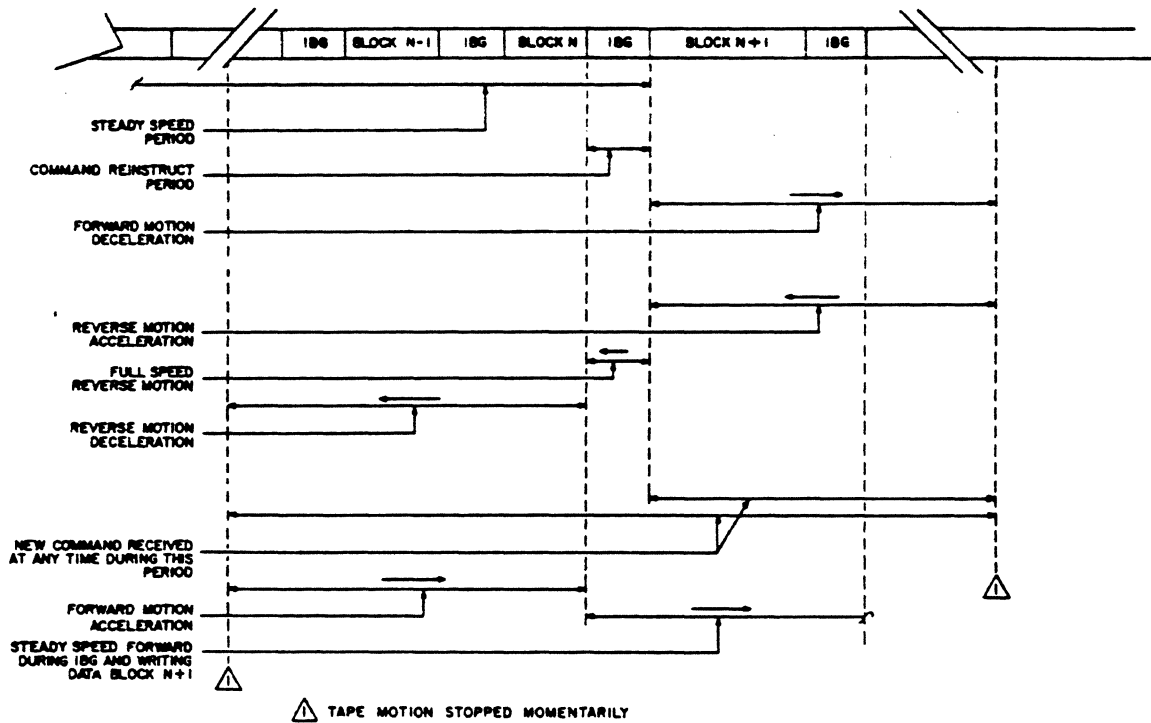

Figure 4-36. Case 2 - Tape Motion Control

Case 3 (Wait For Command)

Command Received Following Repositioning Cycle - This case is very similar to case 2 except that the subsequent command is not received until the tape has come to rest at point E1. The tape is then not accelerated until time E2 when the new command is received. Other than for this delay in receiving the next command, the correspondence between the time and distance domain portrayals is the same for cases 2 and 3 (refer to figure 4-38).

<u>EVENT</u>	<u>Velocity Profile Position</u>
Steady Speed Period	Up to Point A
Forward Motion Deceleration	A-B
Tape Motion Stopped Momentarily	B
Reverse Motion Acceleration	B-C
Full Speed Reverse Motion	C-D
Reverse Motion Deceleration	D-E1
Tape Motion Stopped While Awaiting New Command	E1-E2
Forward Motion Acceleration	E2-F
Steady Speed Forward Through Data Block N + 1	Point F and On

Important to note is that the STU performs all repositioning without system or controller intervention.

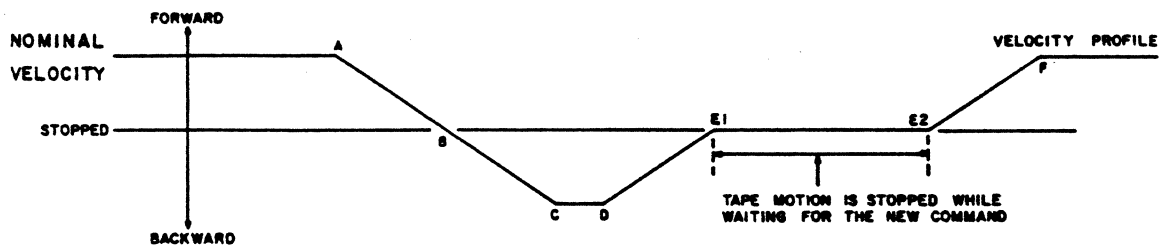

Figure 4-37. Case 3 - Velocity Profile

TAPE MOTION CONTROL

STREAMING MODE - 75 INCHES/SEC OR 25 INCHES/SEC

CASE III - START/STOP (TAPE MOTION IS STOPPED FOR PERIODS LONGER THAN REQUIRED TO CHANGE DIRECTION)

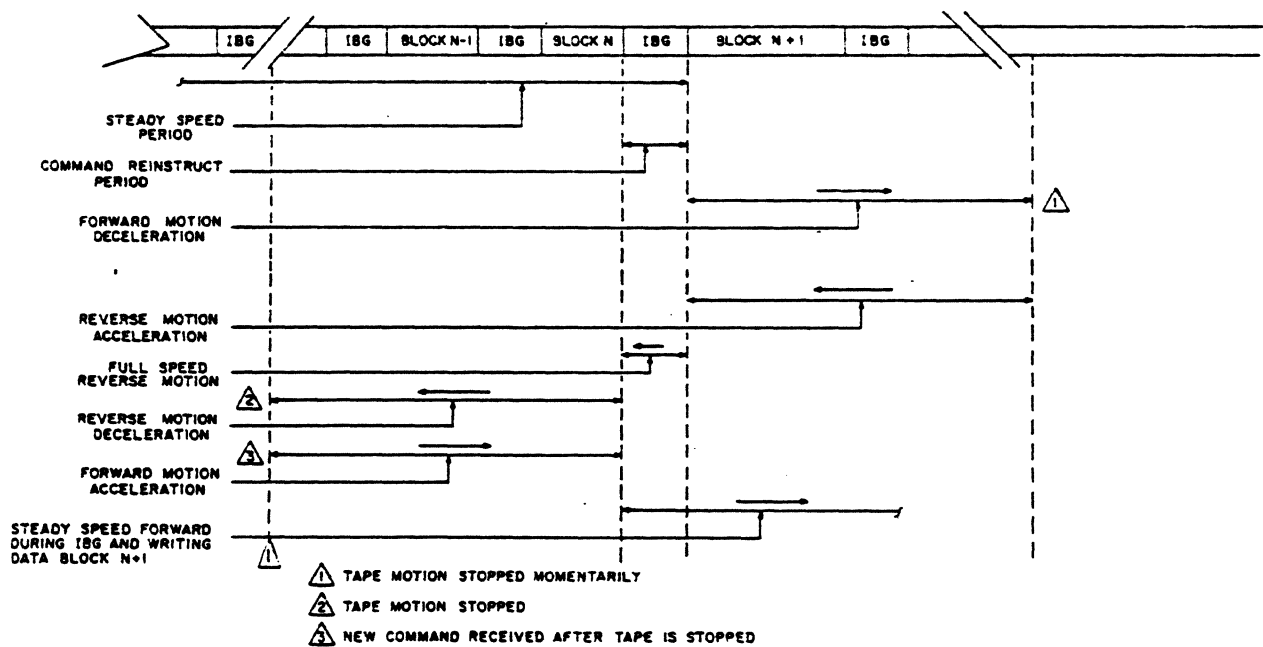

Figure 4-38. Case 3 - Tape Motion Control

## 25 IPS MODE CONTROL

The STU automatically switches between 25 ips streaming mode and 25 ips start/stop mode in response to system usage. Essentially, when repositioning becomes excessive in streaming mode, rather than continue to 'thrash', the STU will switch to start/stop mode.

The STU will switch back to streaming mode when the command Reconstruct Time consistently reduces to a value that would allow streaming.

### NOTE

To avoid 'jog' delays, mode switching is done at 25 ips rather than when stationary. In essence, a mode switch takes effect at the end of the block in process.

## ADAPTIVE VELOCITY CONTROL

With this feature selected, rather than selecting 25 ips mode when low speed is commanded, the STU enters a mode in which the optimum speed is chosen to match system requirements. If 75 ips mode gives the best throughput, then this mode is used; the same applies to 25 ips streaming and 25 ips start/stop. This choice of operating mode is made automatically by the STU and does not require any involvement by the system. This feature allows the STU to be interfaced to a standard adapter and to run under standard 1/2 inch tape software, and yet offer the advantage of streaming.

GENERAL

This section of the manual contains the schematics and logic diagrams for the PWA's contained in the transport. A complete list of boards is shown in the table below and is arranged in sets numerically by the 8-digit control number. Do not attempt to order new PWA's by the 8-digit drawing number on these drawings; instead, use Section 7, Parts Identification, of the manual to order the appropriate replacement assembly.

Preceding the schematics is the main electrical cable diagram. This diagram shows all cables and their respective connectors routed to the various transport assemblies.

Table 5-1. SCHEMATIC INDEX

TITLE	SCHEMATIC
Cable Diagram	77019840
Control Panel	77005910
Formatter Read	77041180
Power Driver	77041190
Write Driver	77041210
Read Amplifier	77041220
Formatter Write	77026110
Power Supply Control	77041280
Power Supply	77041310
Servo-Control	77026090



49763000 K

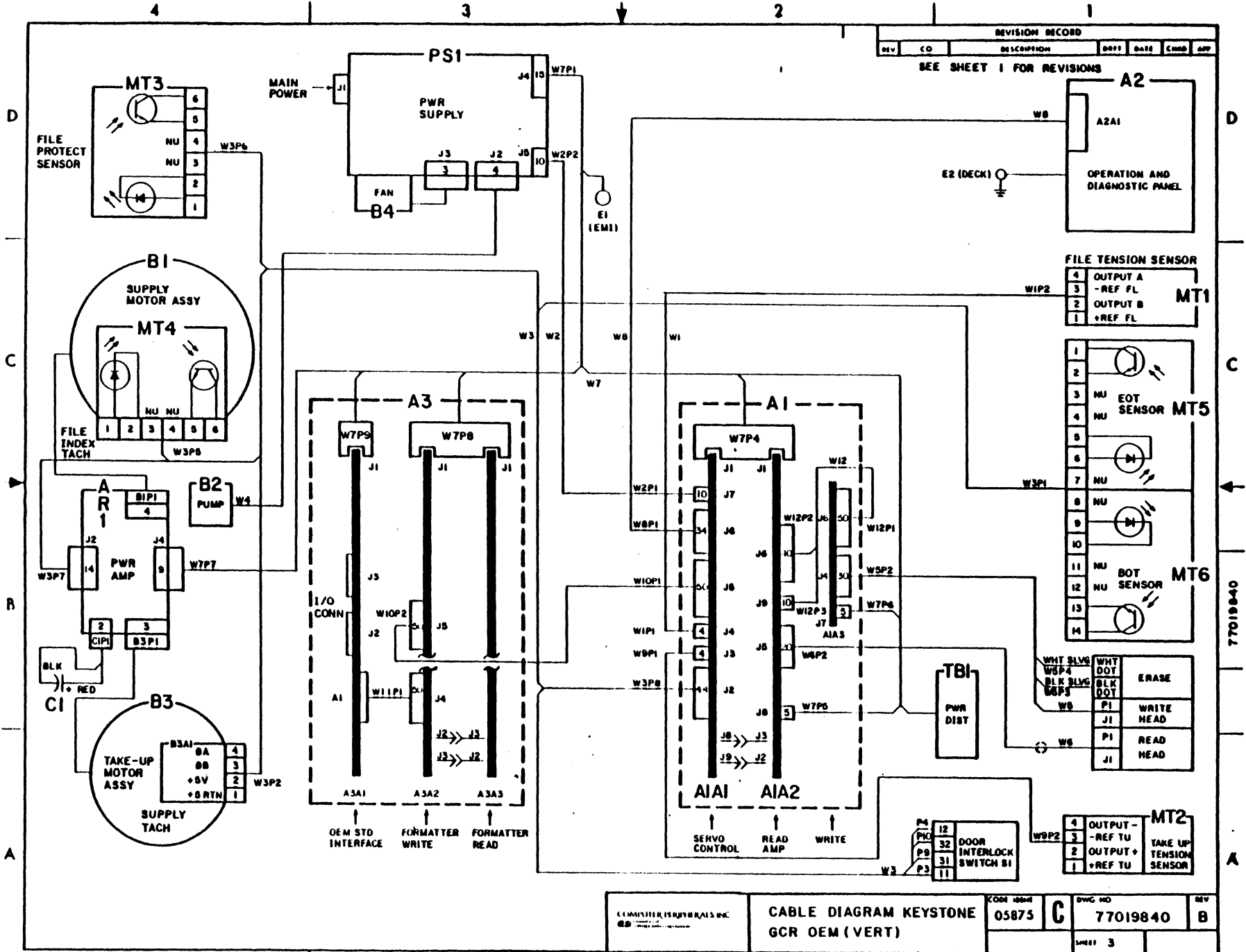

REVISION RECORD					
REV	CO	DESCRIPTION	DEPT	DATE	CHKD

SEE SHEET 1 FOR REVISIONS

FILE TENSION SENSOR	
4	OUTPUT A - REF FL
3	OUTPUT B
2	OUTPUT B
1	+REF FL

1	
2	
3	MU EOT SENSOR
4	MU
5	
6	
7	MU
8	MU
9	
10	
11	MU BOT SENSOR
12	MU
13	
14	

WHT BLVG	WHT DOT	ERASE
WSP4	BLK DOT	PI
BLK BLVG	WSP5	PI
WSP6	PI	READ HEAD
WSP7	PI	HEAD

4	OUTPUT -	MT2
3	-REF TU	TAKE UP
2	OUTPUT +	TENSION
1	+REF TU	SENSOR

LEMMING ELECTRONICS INC.	CABLE DIAGRAM KEYSTONE	CODE 05875	DWG NO	REV
	GCR OEM (VERT)		77019840	B
			SHEET 3	

5-3

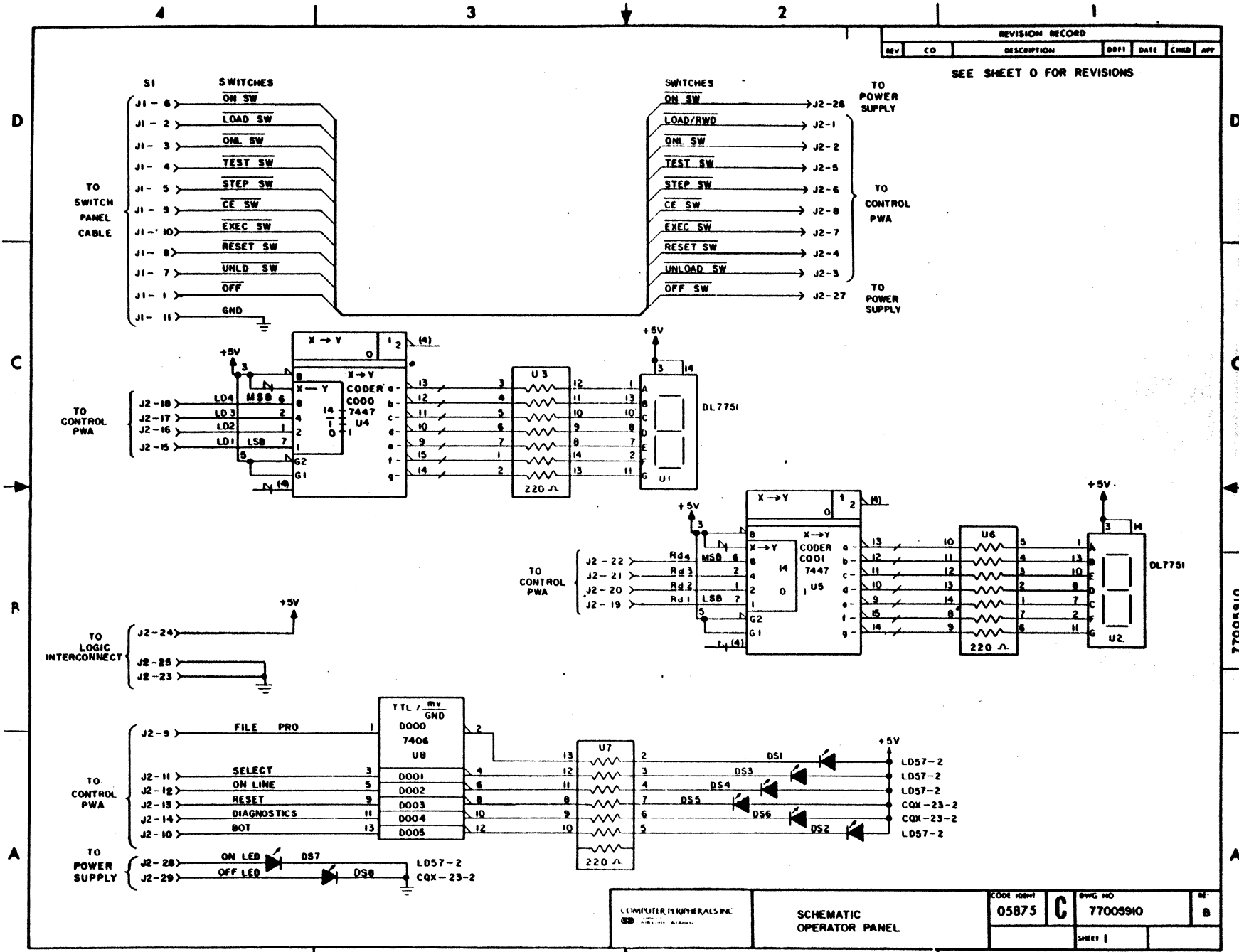

77005910

COMPUTER TERMINALS INC.	SCHMATIC OPERATOR PANEL	CODE IDENT 05875	DRWG NO C	77005910	REV B
		SHEET 1			



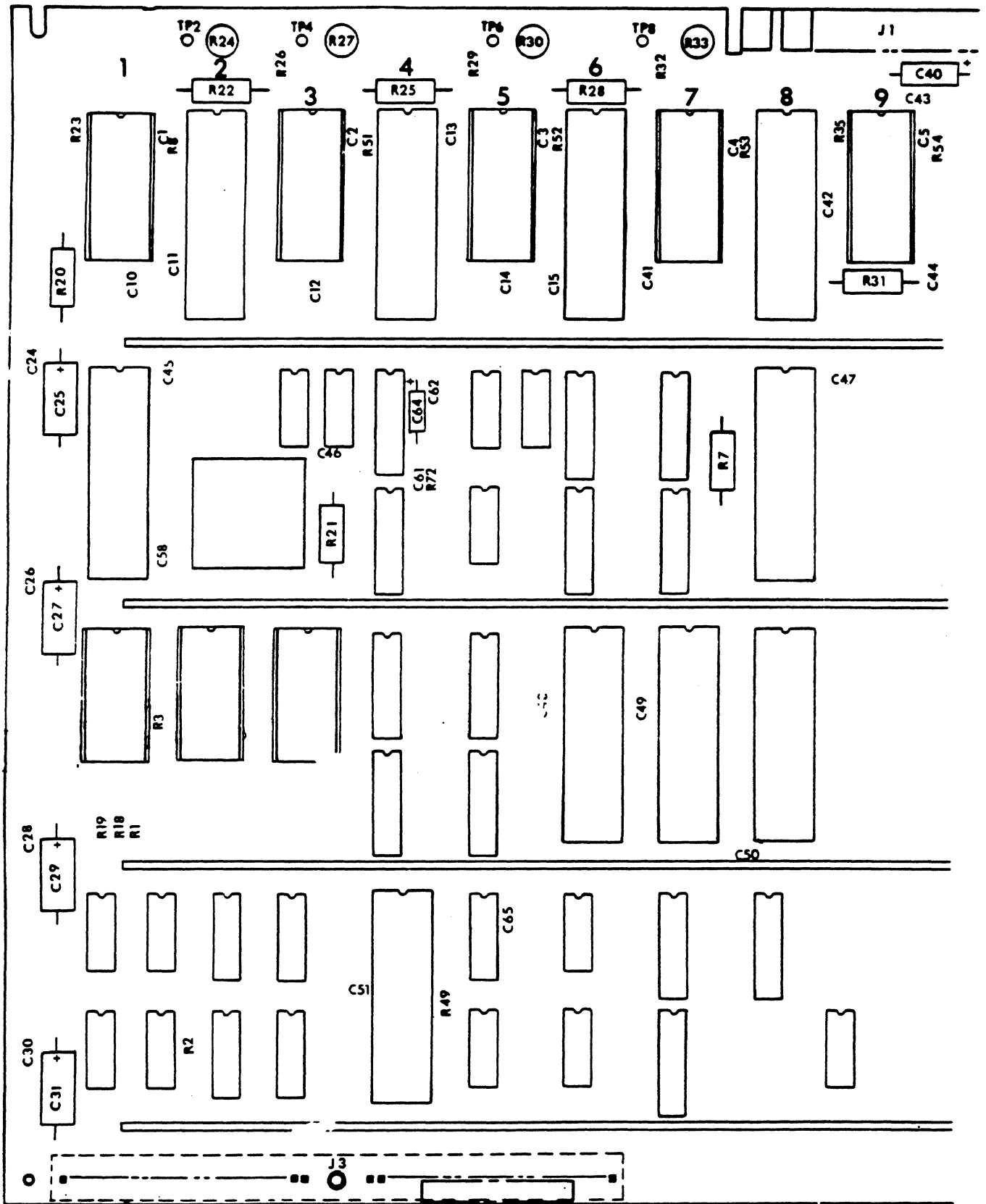

FORMATTER READ PWA 77041180

SHEET 1A

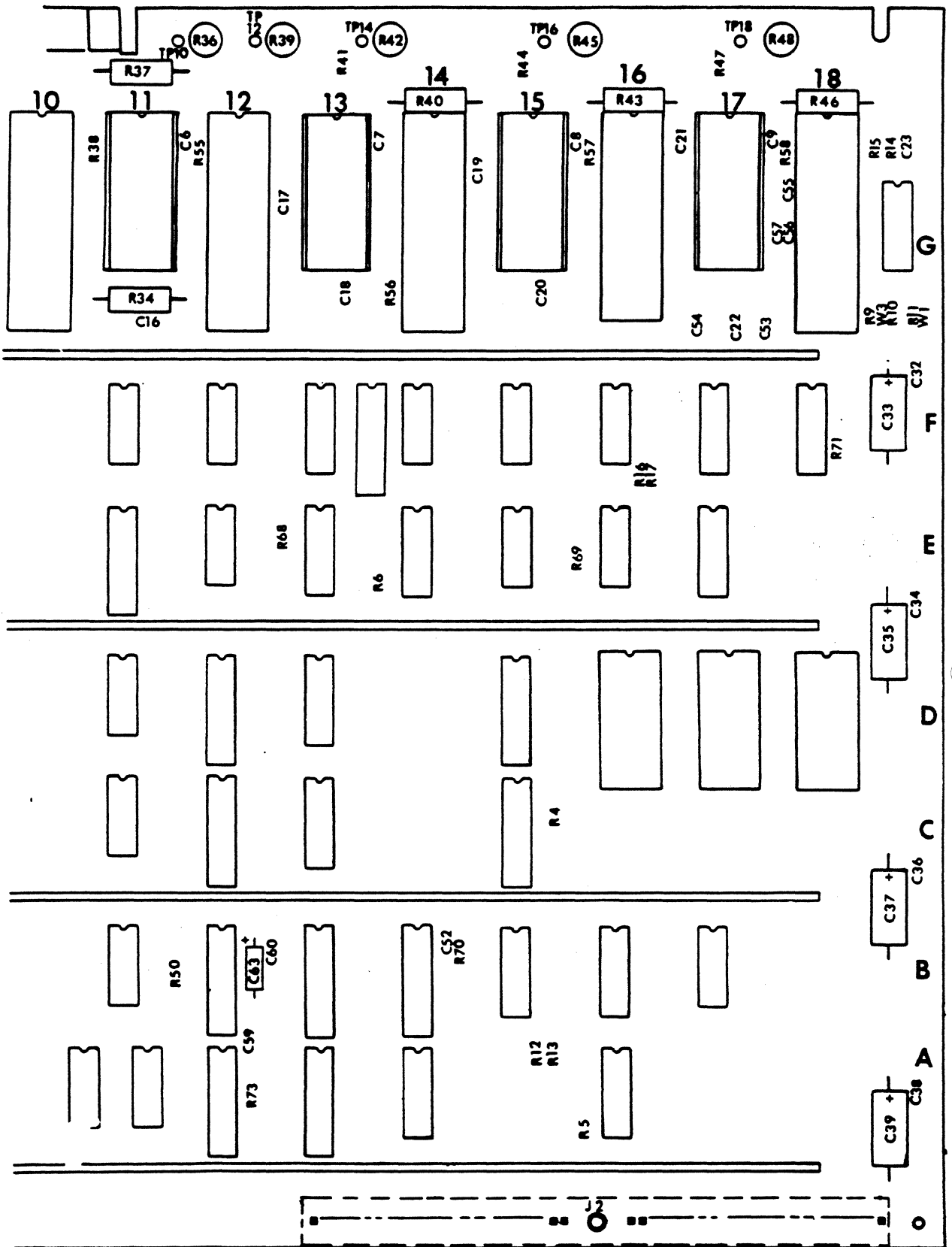

FORMATTER READ PWA 77041180

SHEET 1B

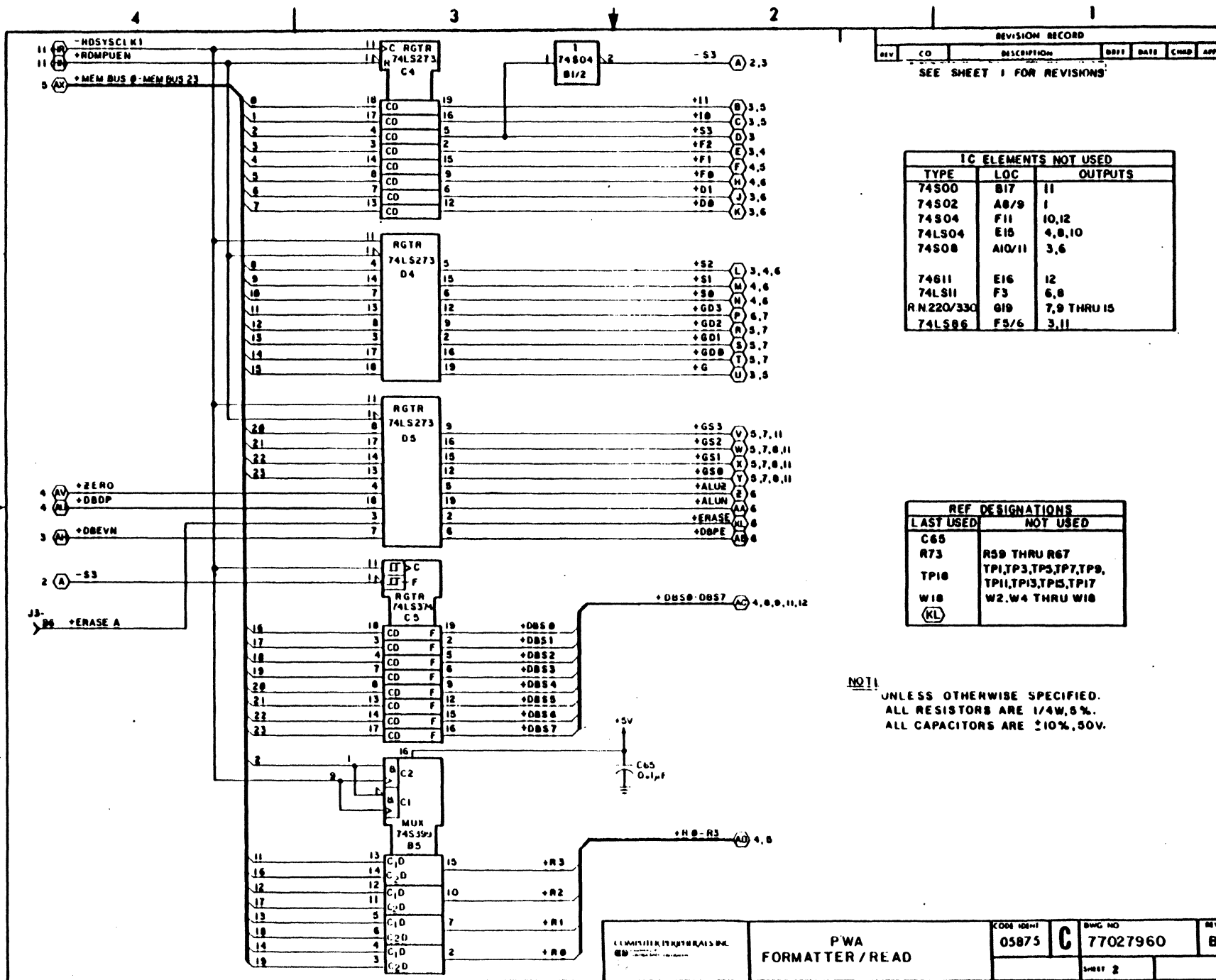

REVISION RECORD						
REV	CO	DESCRIPTION	DATE	CHKD	APP	
SEE SHEET 1 FOR REVISIONS						

IC ELEMENTS NOT USED		
TYPE	LOC	OUTPUTS
74S00	B17	11
74S02	A8/9	1
74S04	F11	10,12
74LS04	E16	4,8,10
74S08	A10/11	3,6
74611	E16	12
74LS11	F3	6,8
RN220/330	G19	7,9 THRU 15
74LS86	F5/6	3,11

REF DESIGNATIONS	
LAST USED	NOT USED
C65	R59 THRU R67
R73	TP1, TP3, TP3, TP7, TP9,
TP16	TP11, TP13, TP15, TP17
W18	W2, W4 THRU W18
(KL)	

**NOTE 1**  
 UNLESS OTHERWISE SPECIFIED.  
 ALL RESISTORS ARE 1/4W, 5%.  
 ALL CAPACITORS ARE ±10%, 50V.

COMPUTER PRODUCTS INC. 600 ... ...	PWA FORMATTER / READ	CODE IDENT	05875	DWG NO	77027960	REV	B
		SHEET	2				

77027960

REVISION RECORD						
REV	CO	DESCRIPTION	DATE	CHKD	APP	
SEE SHEET 1 FOR REVISIONS						

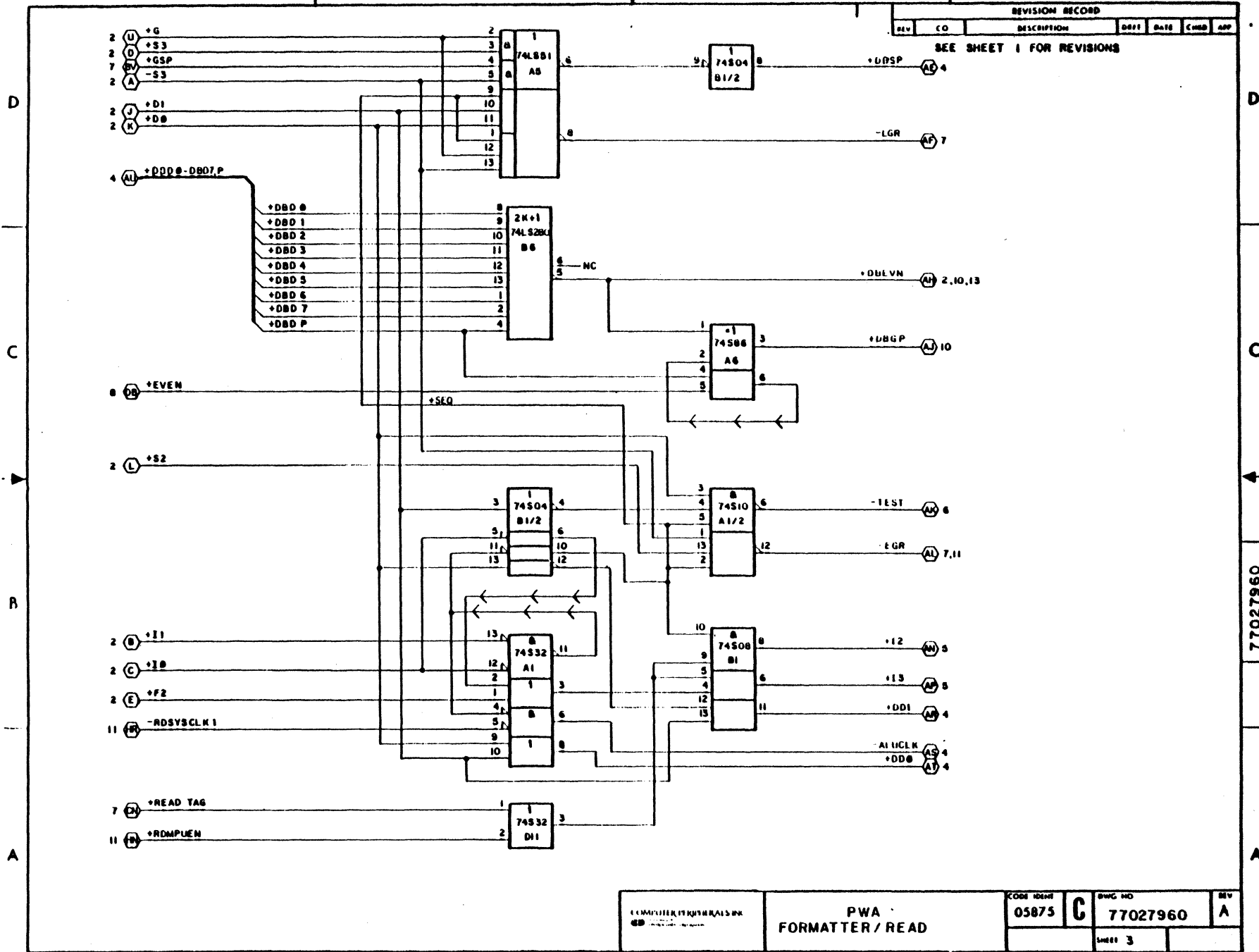

COMPUTER PERIPHERALS INC.	PWA FORMATTER / READ	CODE IDENT 05875	Q	DWG NO 77027960	REV A
				SHEET 3	

77027960

49763000 K

5-9

REVISION RECORD						
REV	CO	DESCRIPTION	DIFF	DATE	CHKD	APP
SEE SHEET 1 FOR REVISIONS						

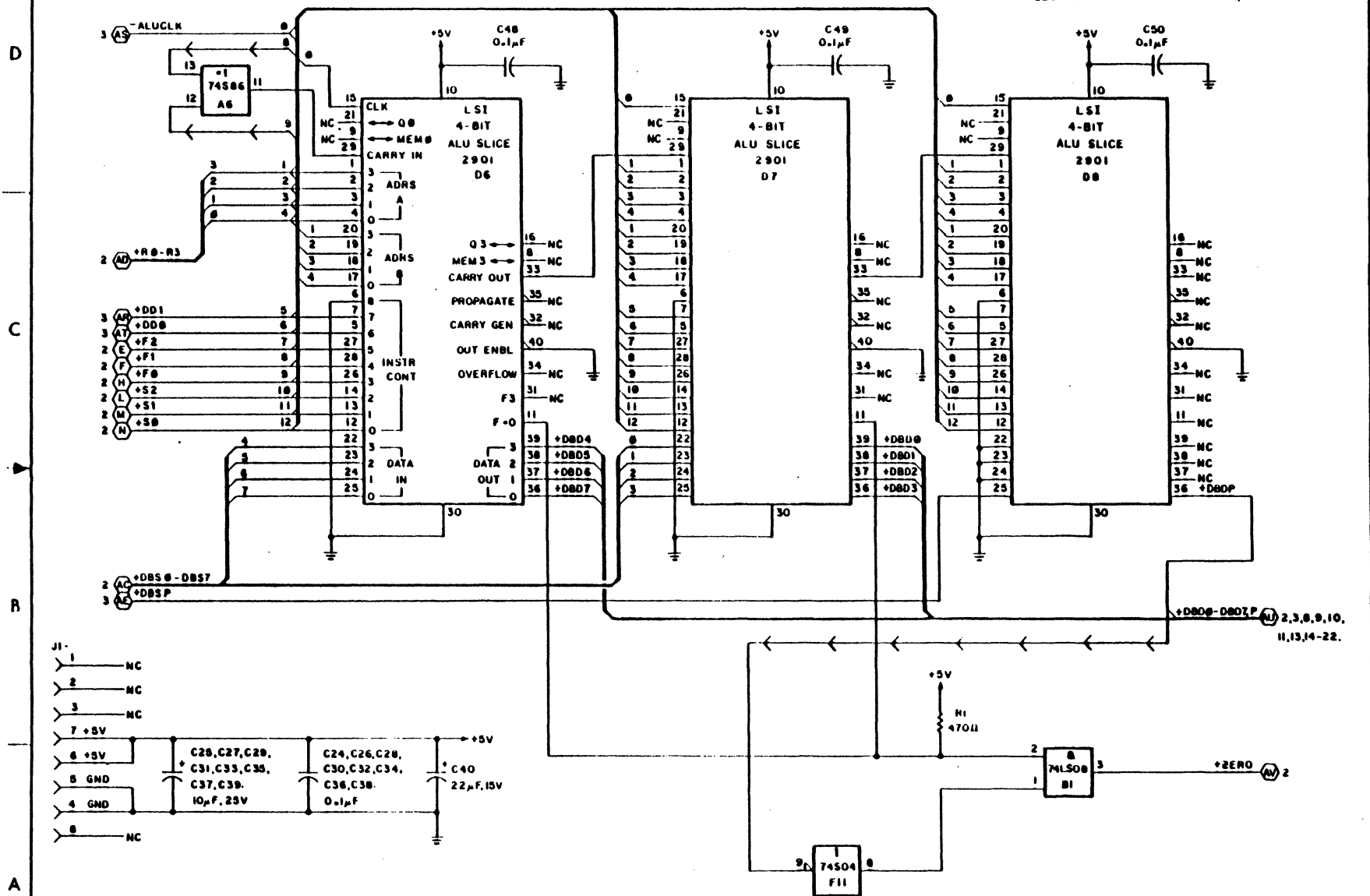

77027960

CONSOLIDATED ELECTRONICS INC. 600 ... ...	PWA FORMATTER/READ		CODE IDENT 05875	DWG NO. C 77027960	REV A
			SHEET 4		

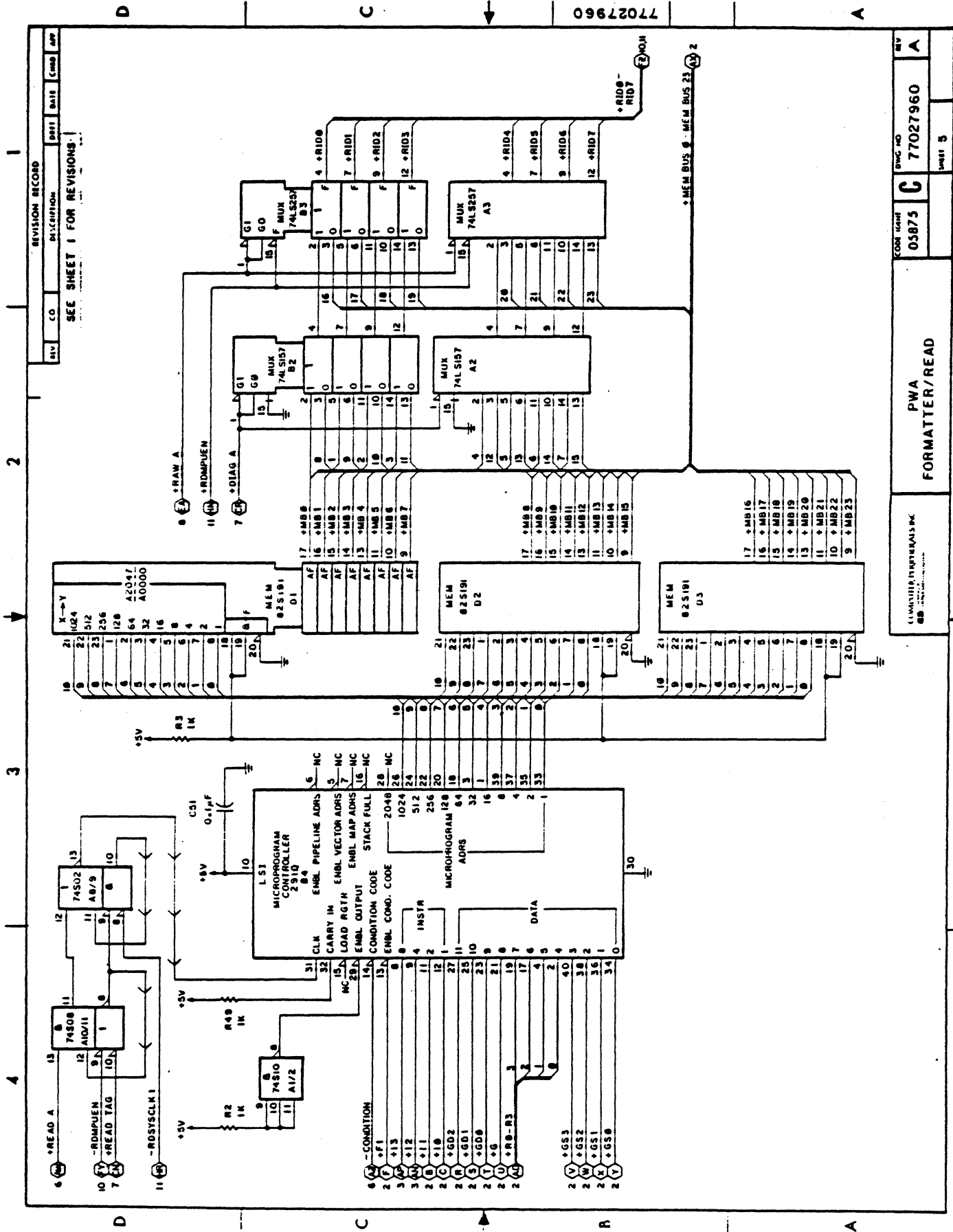

49763000 K

5-11

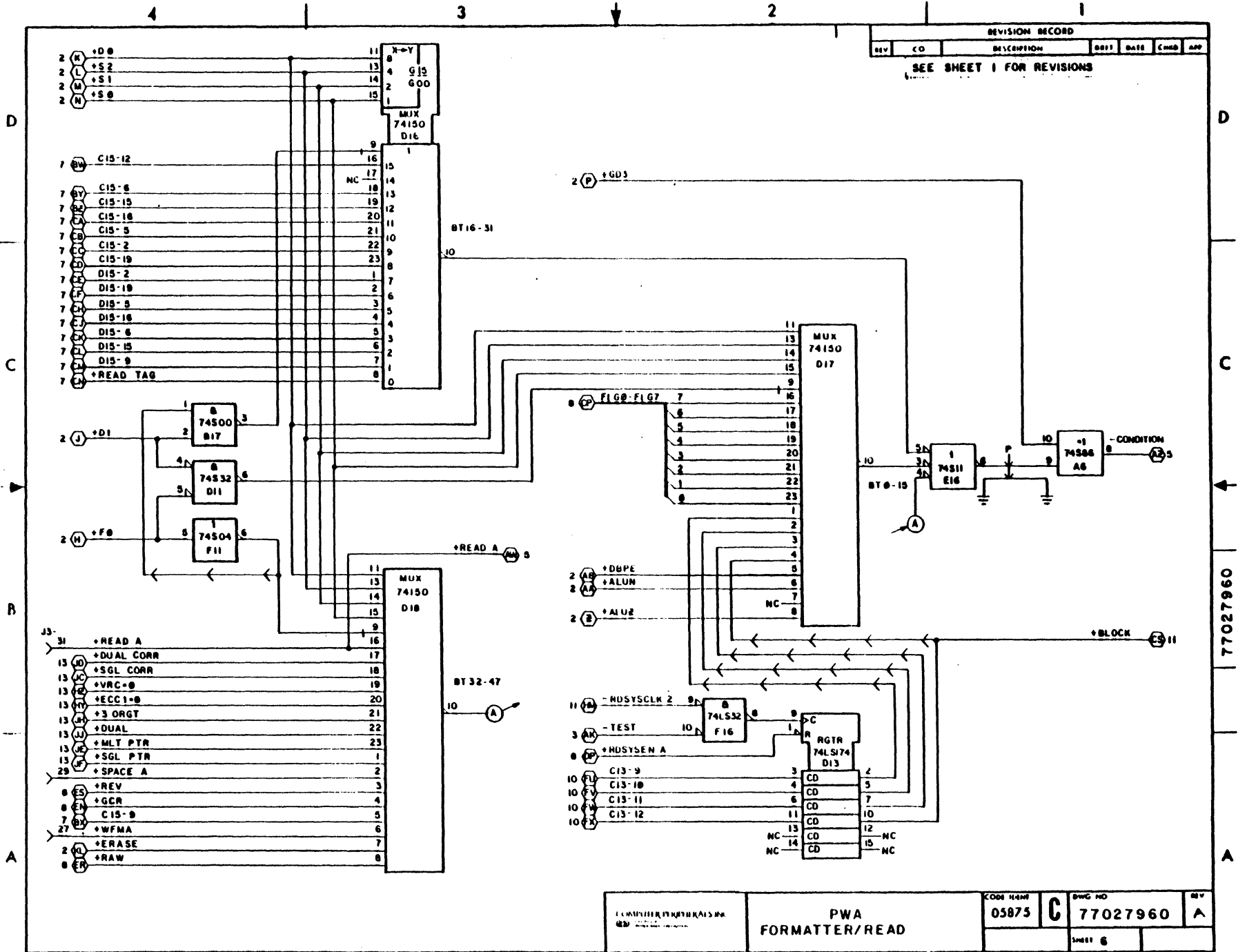

REVISION RECORD						
REV	CO	DESCRIPTION	DATE	CHKD	APP	
SEE SHEET 1 FOR REVISIONS						

CONSULT THE DATA SHEET FOR THE LOGIC SYMBOLS.	PWA FORMATTER/READ		CODE NAME <b>05875</b>	DWG NO <b>77027960</b>	REV <b>A</b>
				SHEET <b>6</b>	

PG 112 Rev 1-15-76

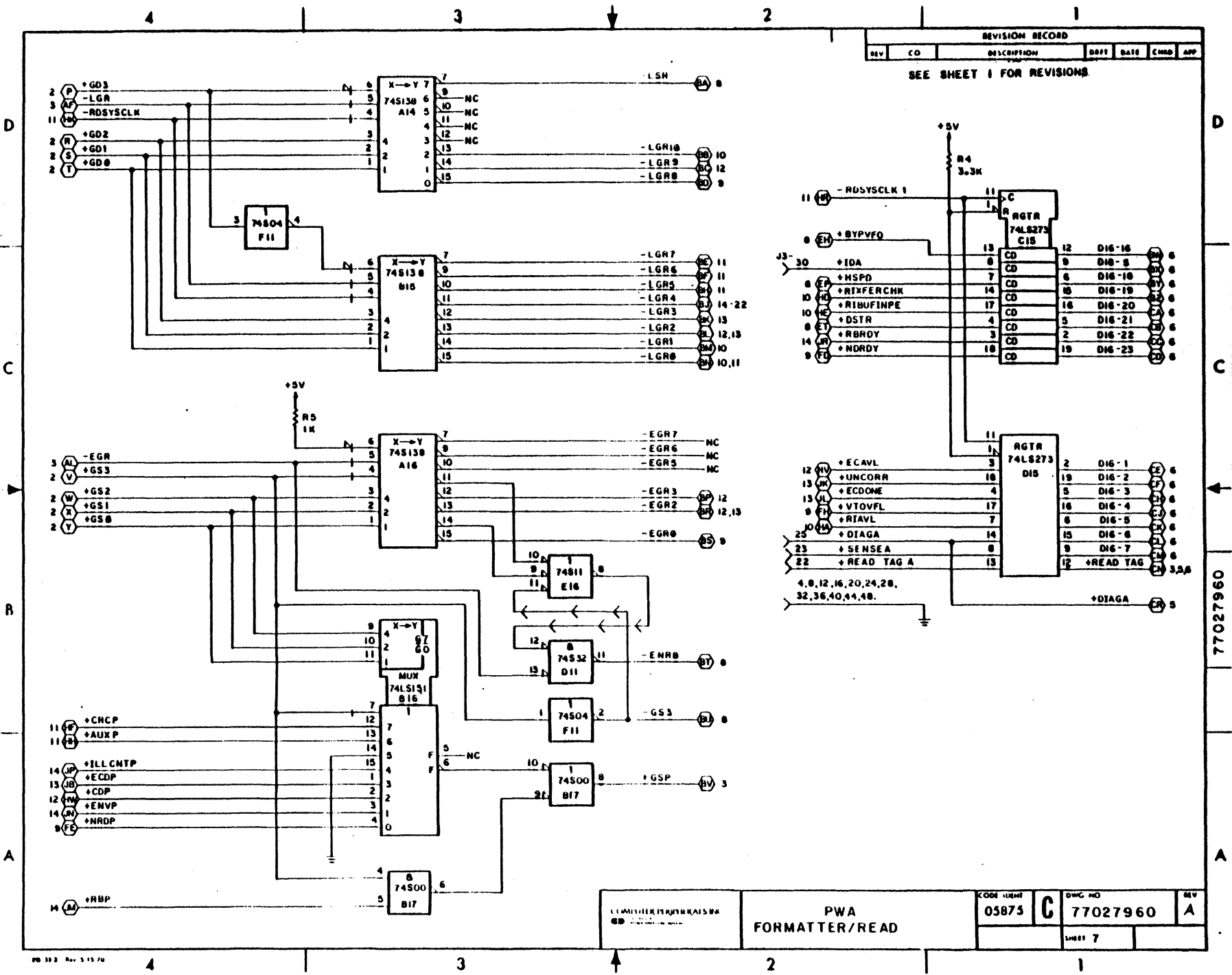

WD 302 Rev. 3-15-70



49763000 K

5-13

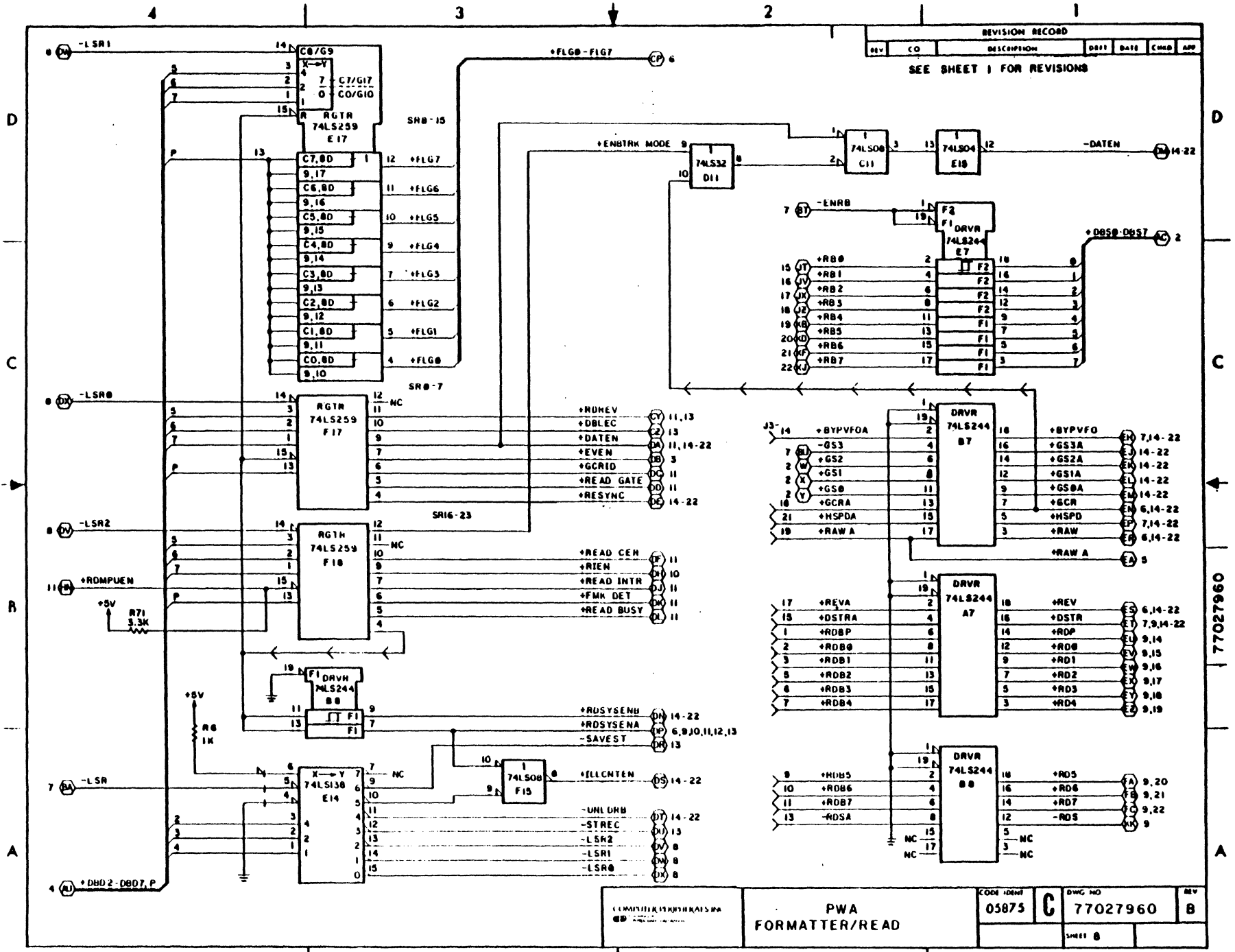

COMPUTER RESEARCH SYSTEMS INC.

**PWA FORMATTER/READ**

CODE IDENT: 05875 C DWG NO: 77027960 REV: B

SHEET 8

REVISION RECORD						
REV	CO	DESCRIPTION	DATE	CHKD	APP	
SEE SHEET 1 FOR REVISIONS						

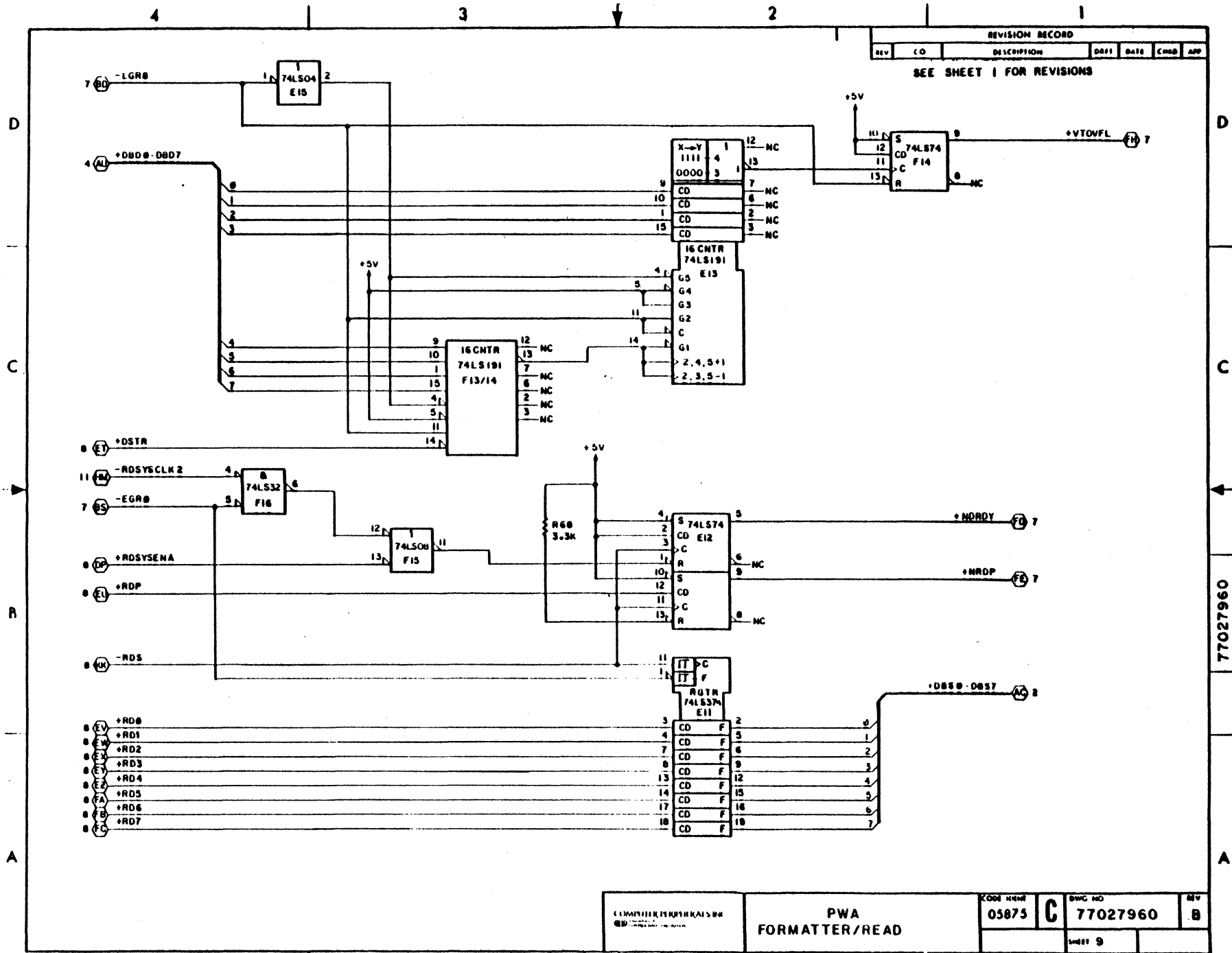

COMPUTER PERIPHERALS INC. 10000 W. CENTRAL EXP. HWY. HOUSTON, TEXAS 77050	<b>PWA FORMATTER/READ</b>		CODE WORD <b>05875</b>	DWG NO <b>C 77027960</b>	REV <b>B</b>
				SHEET 9	

77027960

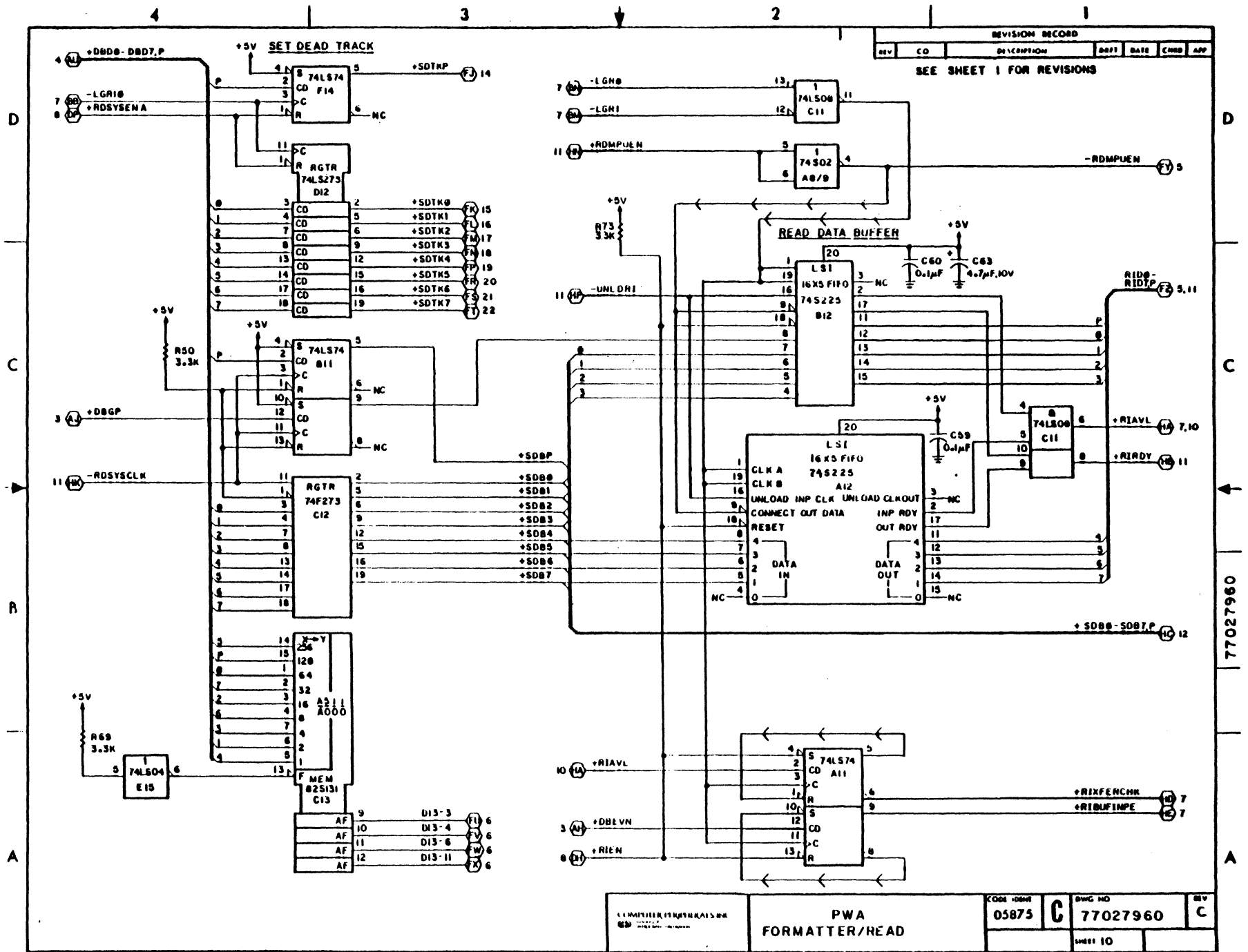

77027960

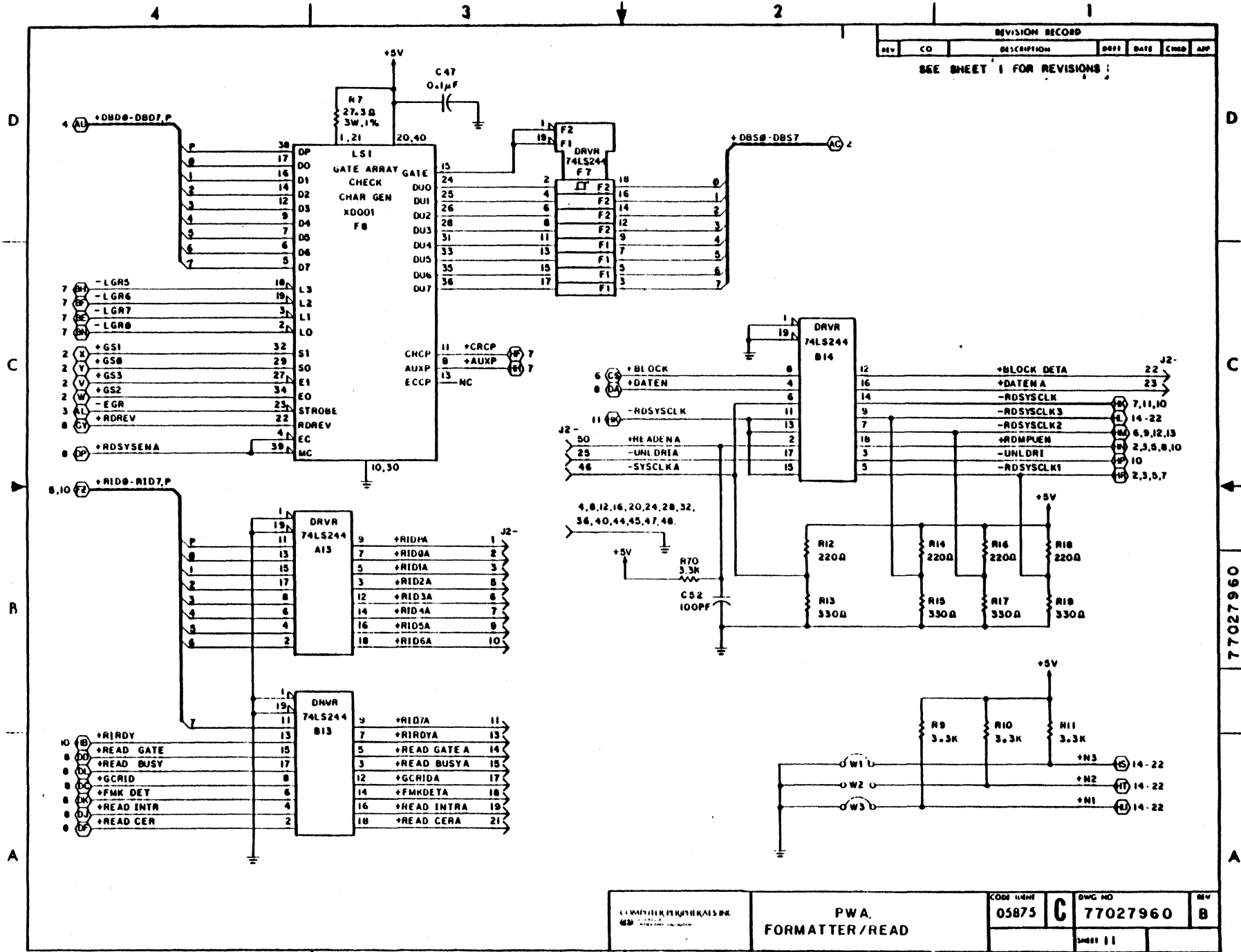

REVISION RECORD						
REV	CO	DESCRIPTION	DRFT	DATE	CHGD	APP

SEE SHEET 1 FOR REVISIONS

COMPUTER PERIPHERALS INC. 6800 UNIVERSITY BLVD. NORTH RICHMOND, VA 23060	PWA FORMATTER/READ		CODE IDENT	C	DWG NO	77027960	REV	B
			05875					
SHEET 11								

7 7027960

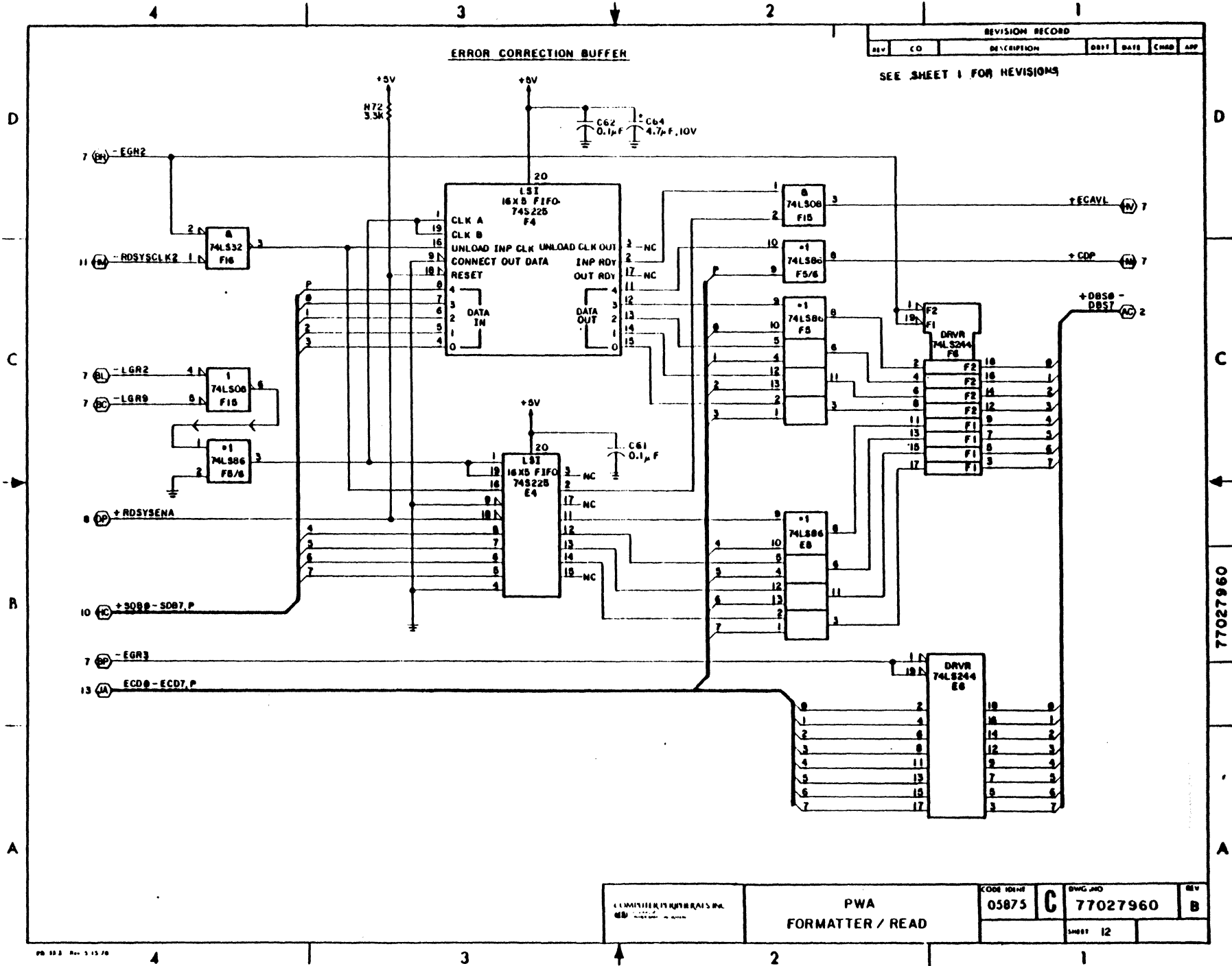

COMPUTER PRODUCTS INC.	PWA FORMATTER / READ	CODE ID# 05875	C	DWG NO 77027960	REV B
				SHEET 12	

77027960

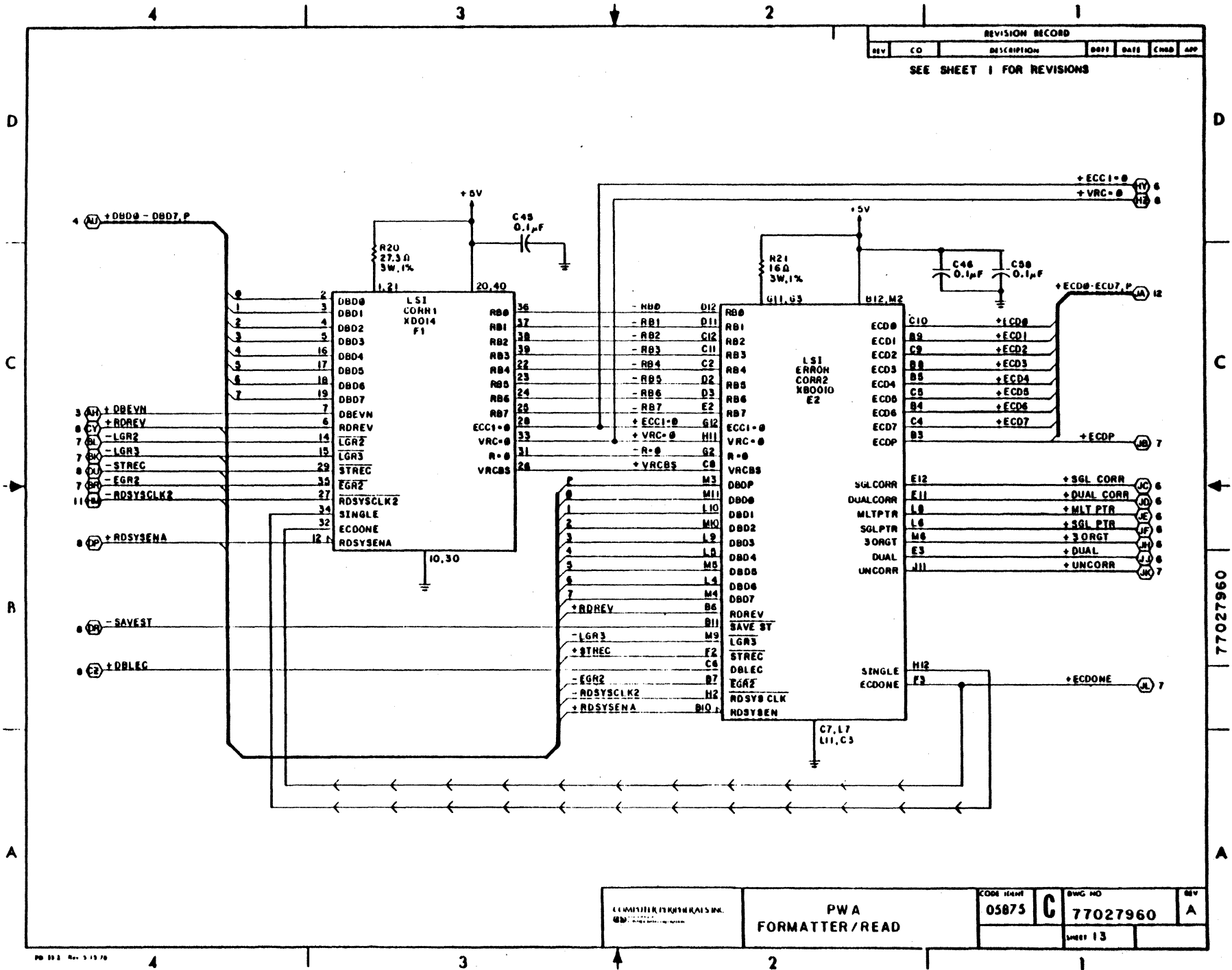

77027960

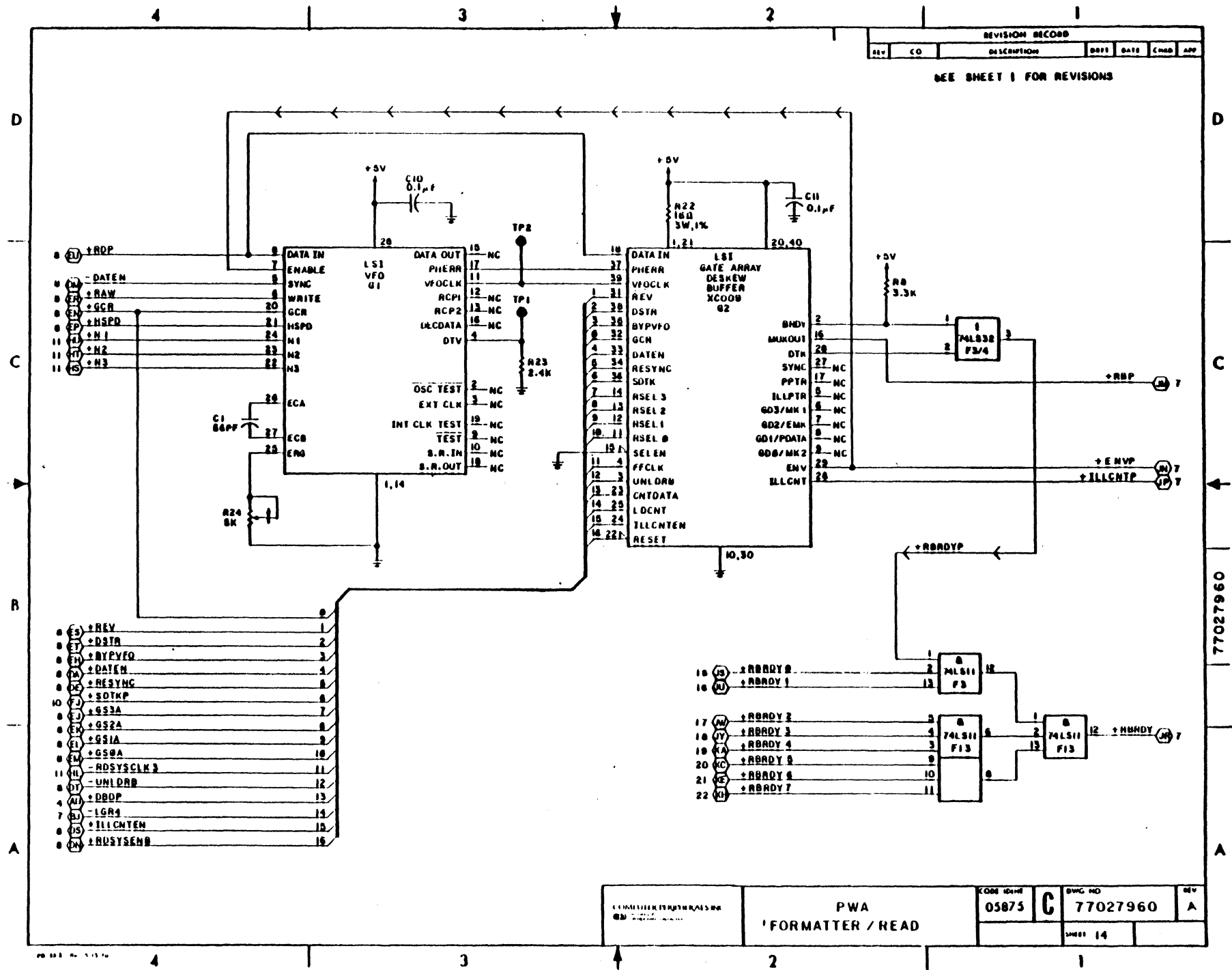

REVISION RECORD						
REV	CO	DESCRIPTION	DATE	BY	CHKD	APP
SEE SHEET 1 FOR REVISIONS						

77027960

COMPUTER TERMINALS INC	PWA	CODE 05875	C	SWG NO 77027960	REV A
	'FORMATTER / READ			SHEET 14	

REVISION RECORD						
REV	CO	DESCRIPTION	DATE	CHKD	APP	

SEE SHEET 1 FOR REVISIONS

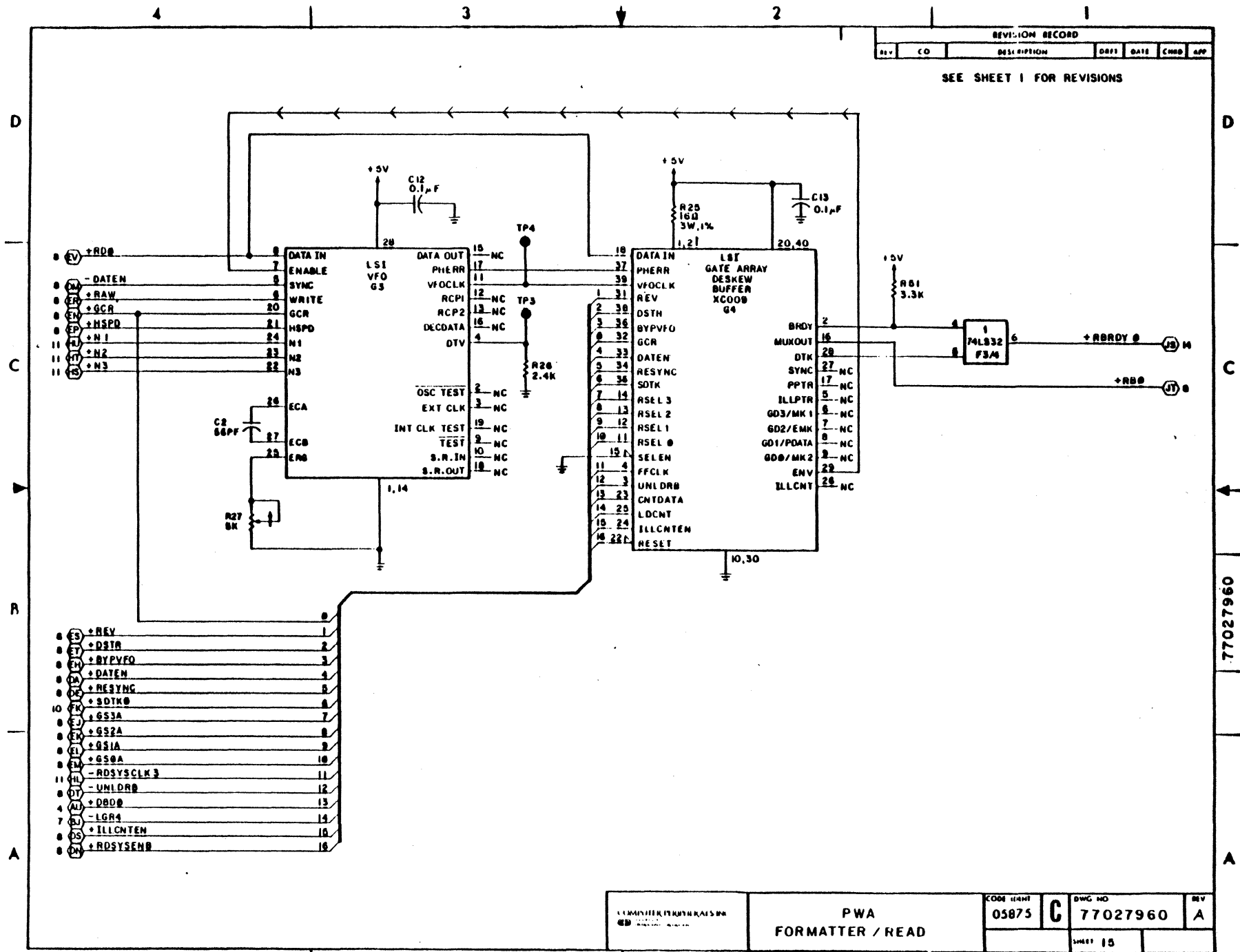

- 1 +REV
- 2 +DSTR
- 3 +BYPVFO
- 4 +DATEN
- 5 +RESYNC
- 6 +SDTK0
- 7 +G53A
- 8 +G52A
- 9 +G51A
- 10 +G50A
- 11 -RDSYSClk 3
- 12 -UNLDRB
- 13 +DDB0
- 14 -LGR4
- 15 +ILLCNTEN
- 16 +RDSYSENB

77027960

1 1 1 2 2 2 3 3 3 4 4 4	PWA FORMATTER / READ		CODE (UNIT) 05875	<b>C</b> DWG NO 77027960 SHEET 15	REV A



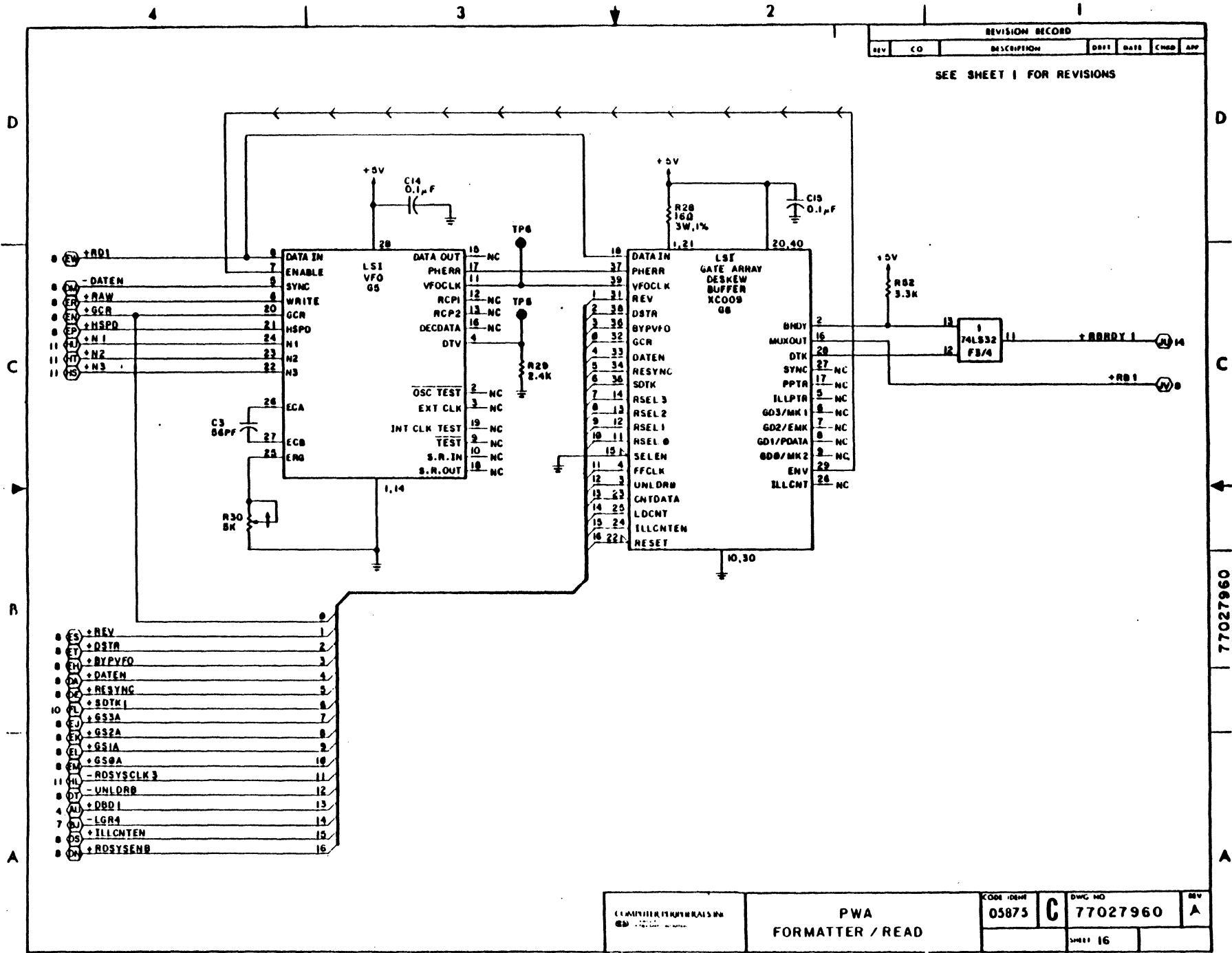

REVISION RECORD						
REV	CO	DESCRIPTION	DATE	CHKD	APP	

SEE SHEET 1 FOR REVISIONS

77027960

COMPUTER PERIPHERALS DIV 6000 ...	PWA FORMATTER / READ	CODE IDENT	DWG NO	REV
		05875	C 77027960	A
		SHEET 16		

REVISION RECORD						
REV	CO	DESCRIPTION	DATE	ENGR	APP	
SEE SHEET 1 FOR REVISIONS						

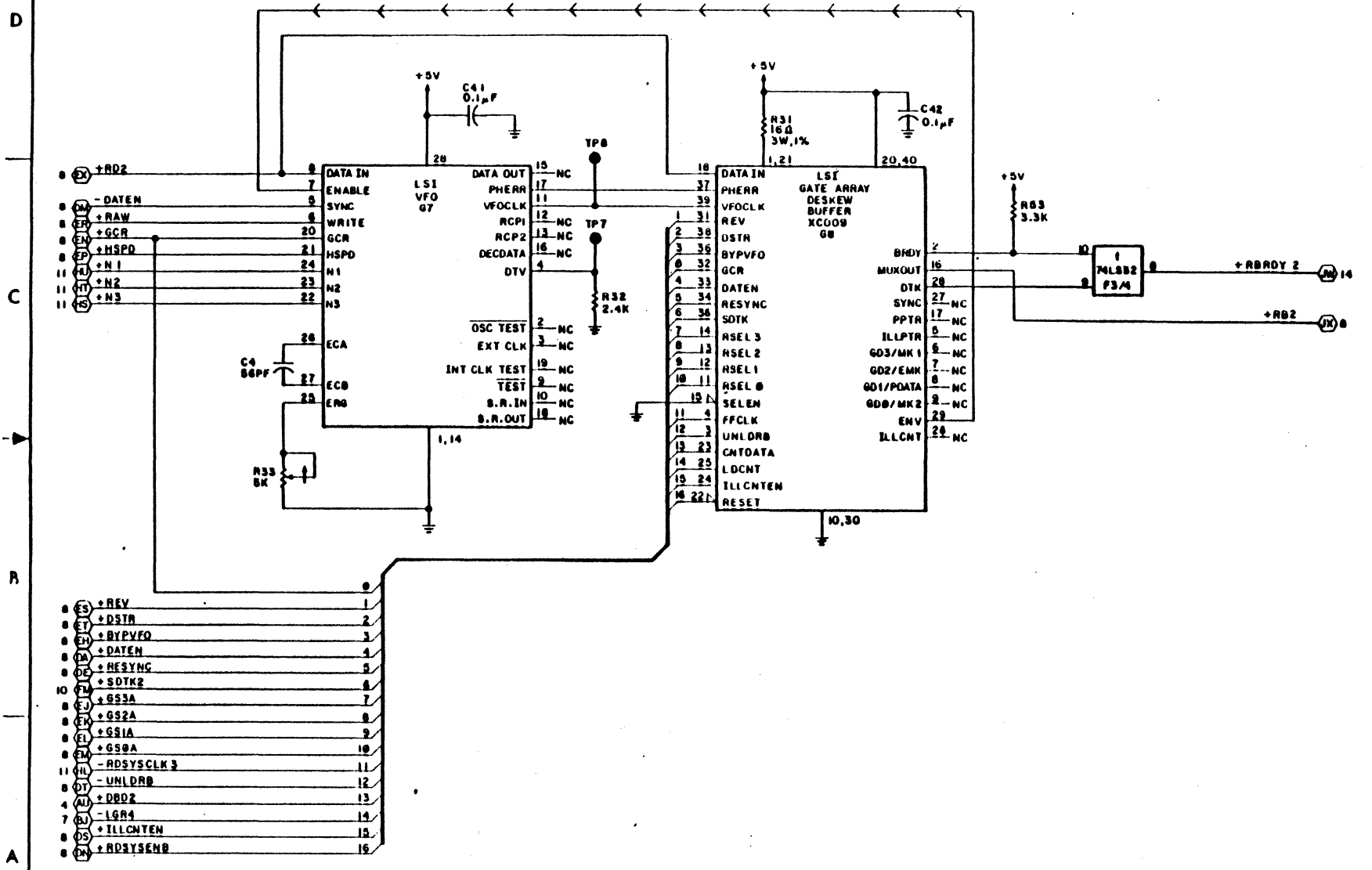

77027960

1. UNIT IDENTIFICATION 2. PART NUMBER	PWA FORMATTER / READ	CODE IDENT 05875	DWG NO C 77027960	REV A
			SHEET 17	

49763000 K

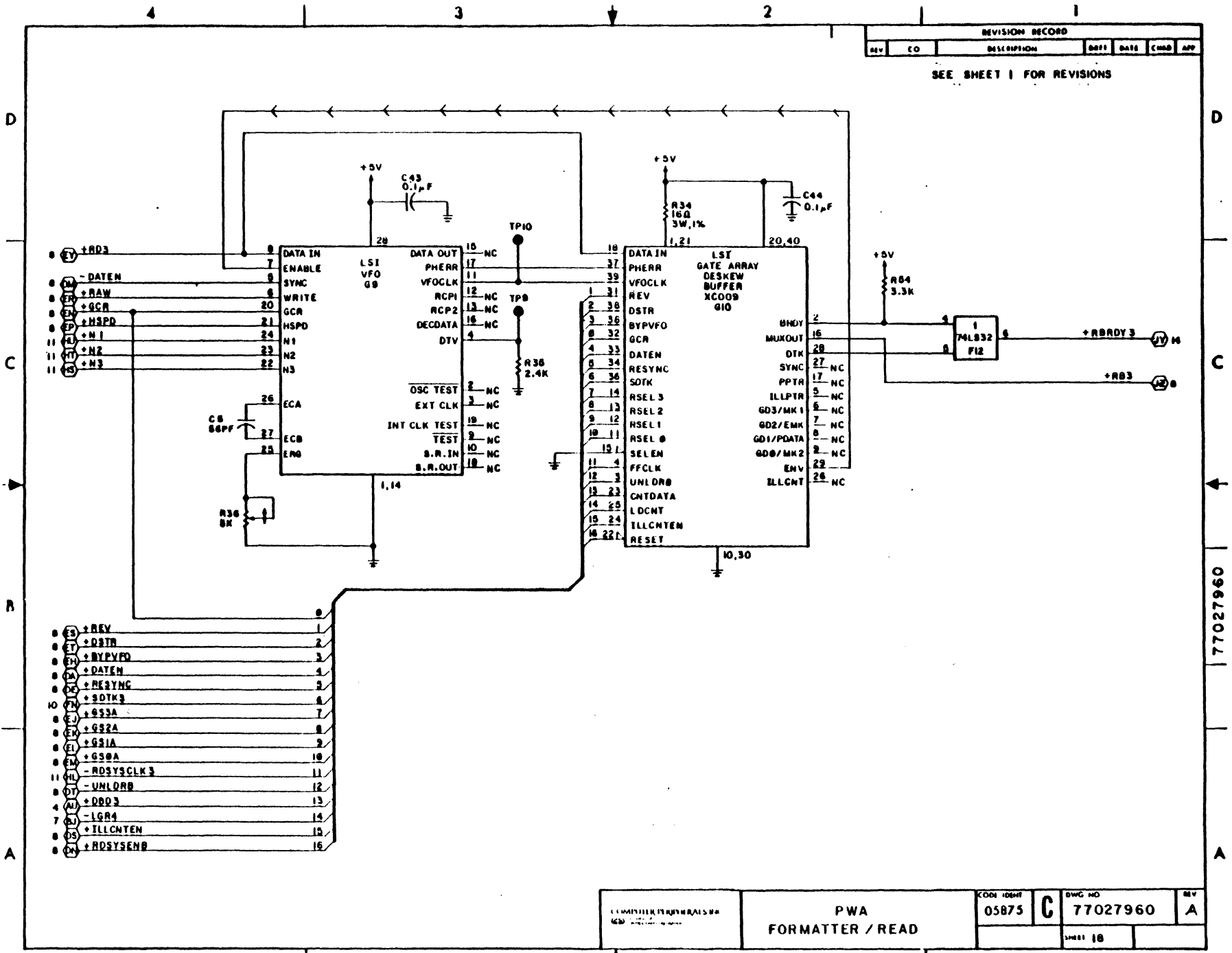

REVISION RECORD					
REV	CO	DESCRIPTION	DIFF	DATE	CHKD APP

SEE SHEET 1 FOR REVISIONS

77027960

COMPUTER PERIPHERALS BR	PWA		CODE IDENT	DWG NO	REV
	FORMATTER / READ		05875	C 77027960	A
			SHEET 18		

5-23

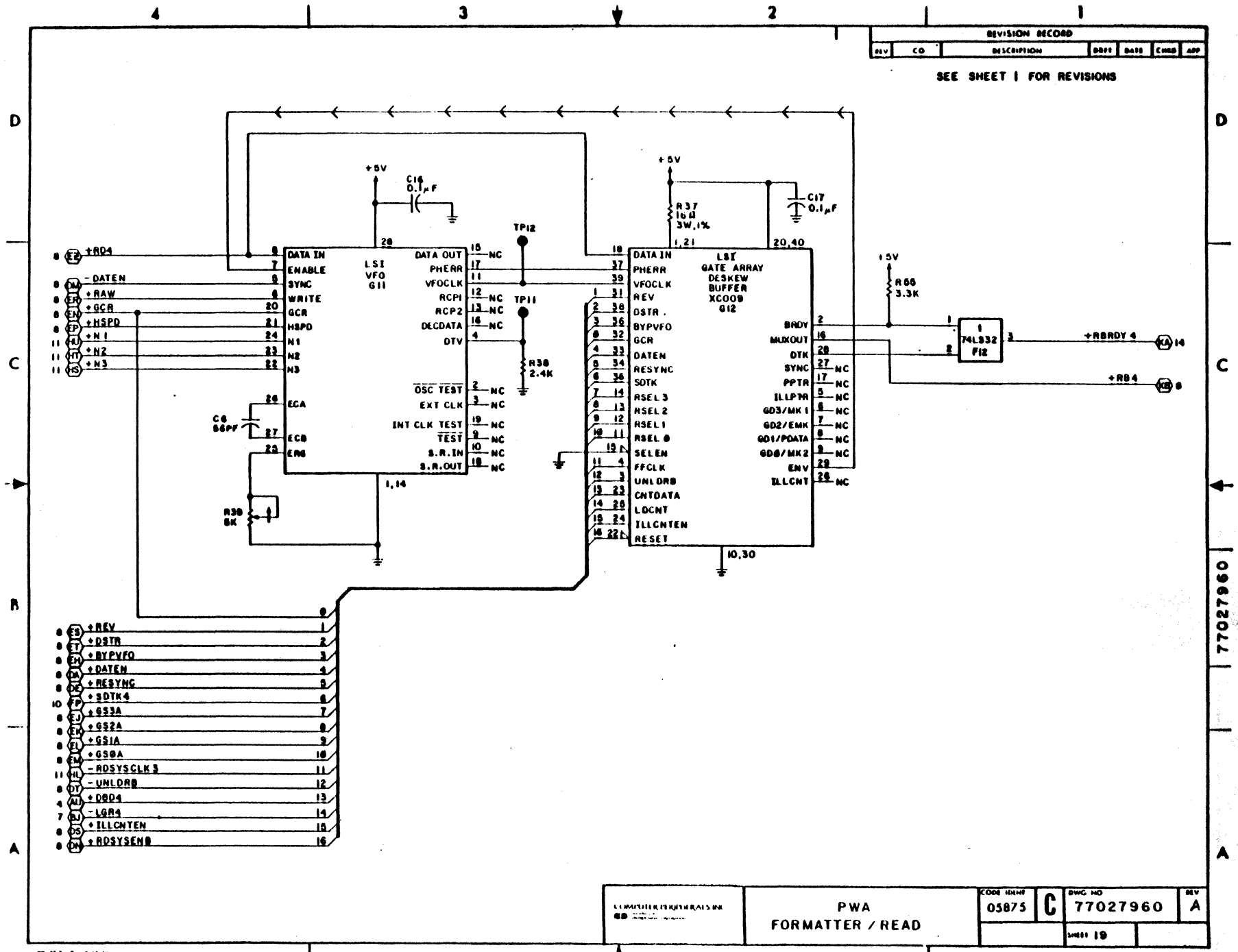

REVISION RECORD					
REV	CO	DESCRIPTION	DATE	CHKD	APP

SEE SHEET 1 FOR REVISIONS

77027960

COMPUTER PERIPHERALS INC 10000 WILSON BLVD DALLAS, TEXAS 75243	PWA FORMATTER / READ	CODE IDENT	DWG NO	REV
		05875 C	77027960	A
		SHEET 18		

49763000 K

5-25

REVISION RECORD					
REV	CO	DESCRIPTION	DATE	CHKD	APP
SEE SHEET 1 FOR REVISIONS					

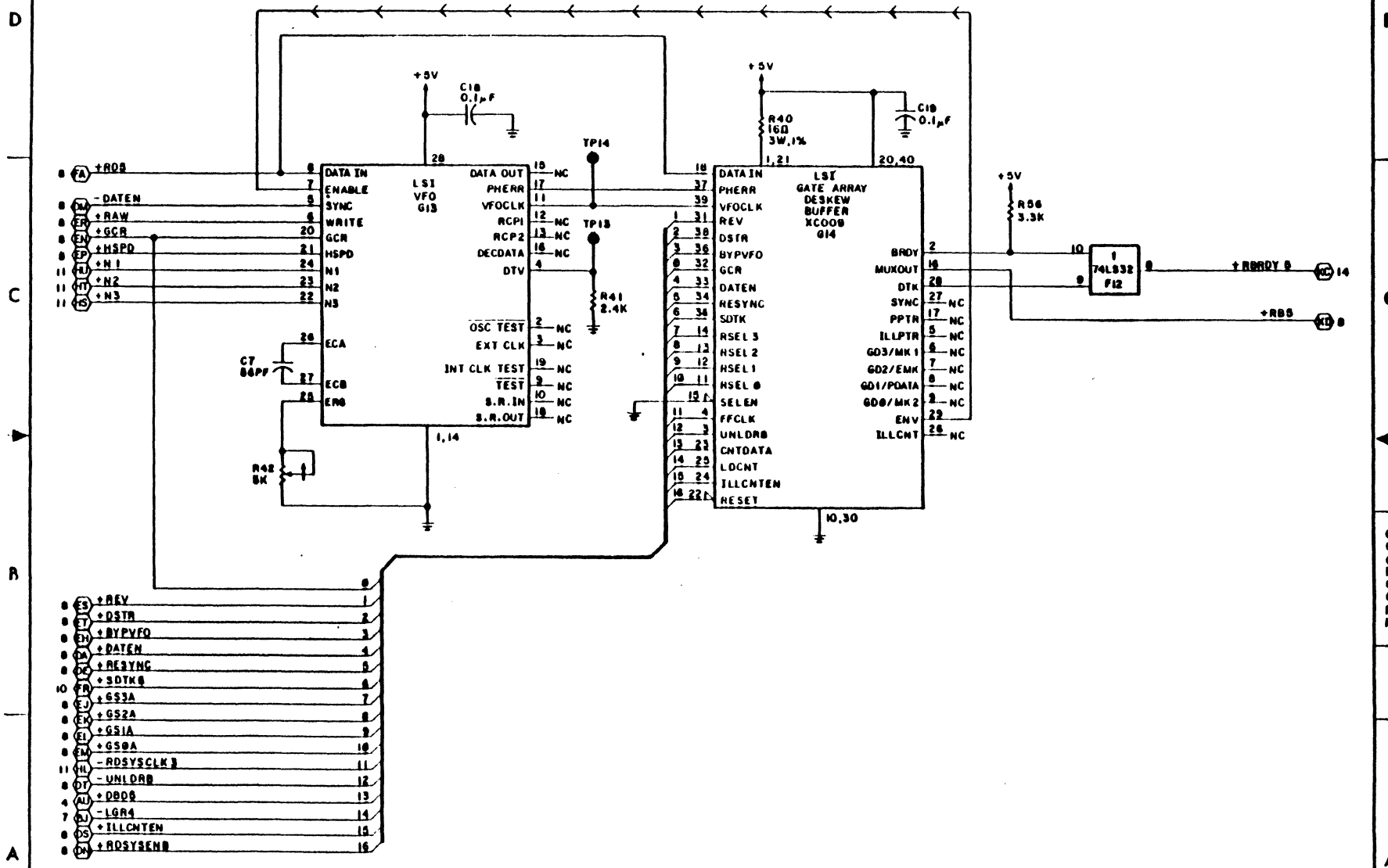

77027960

COMPUTER PRODUCTS INC 600 ... ...	PWA FORMATTER / READ	CODE DESK 05875	DWG NO <b>C</b> 77027960	REV A
		SHEET 20		

REVISION RECORD					
REV	CD	DESCRIPTION	DOY	DATE	ENR

SEE SHEET 1 FOR REVISIONS

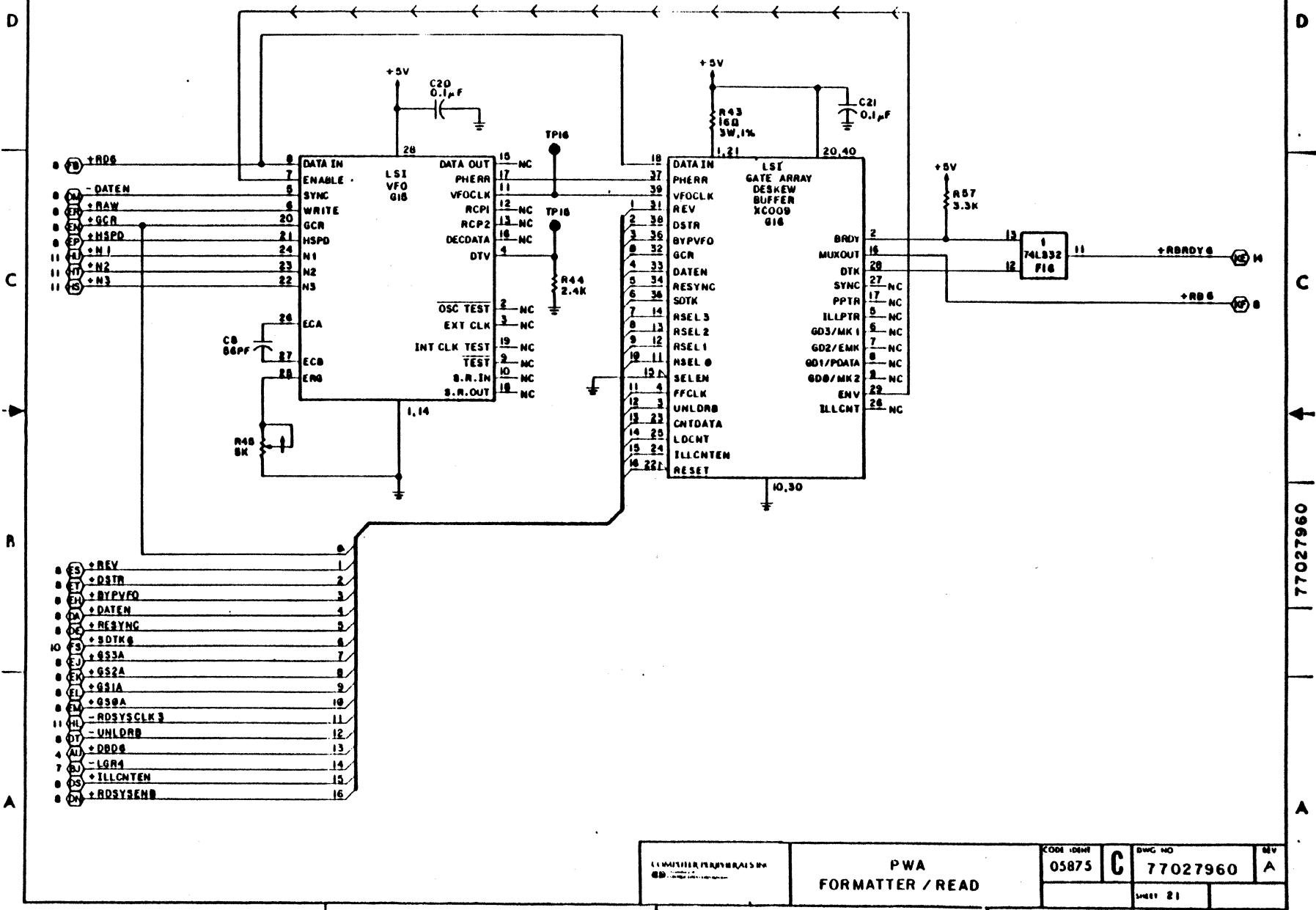

77027960

COMPUTER MANUFACTURING CORPORATION	PWA FORMATTER / READ		CODE IDENT 05875	C	DRWG NO 77027960	REV A
					SHEET 21	

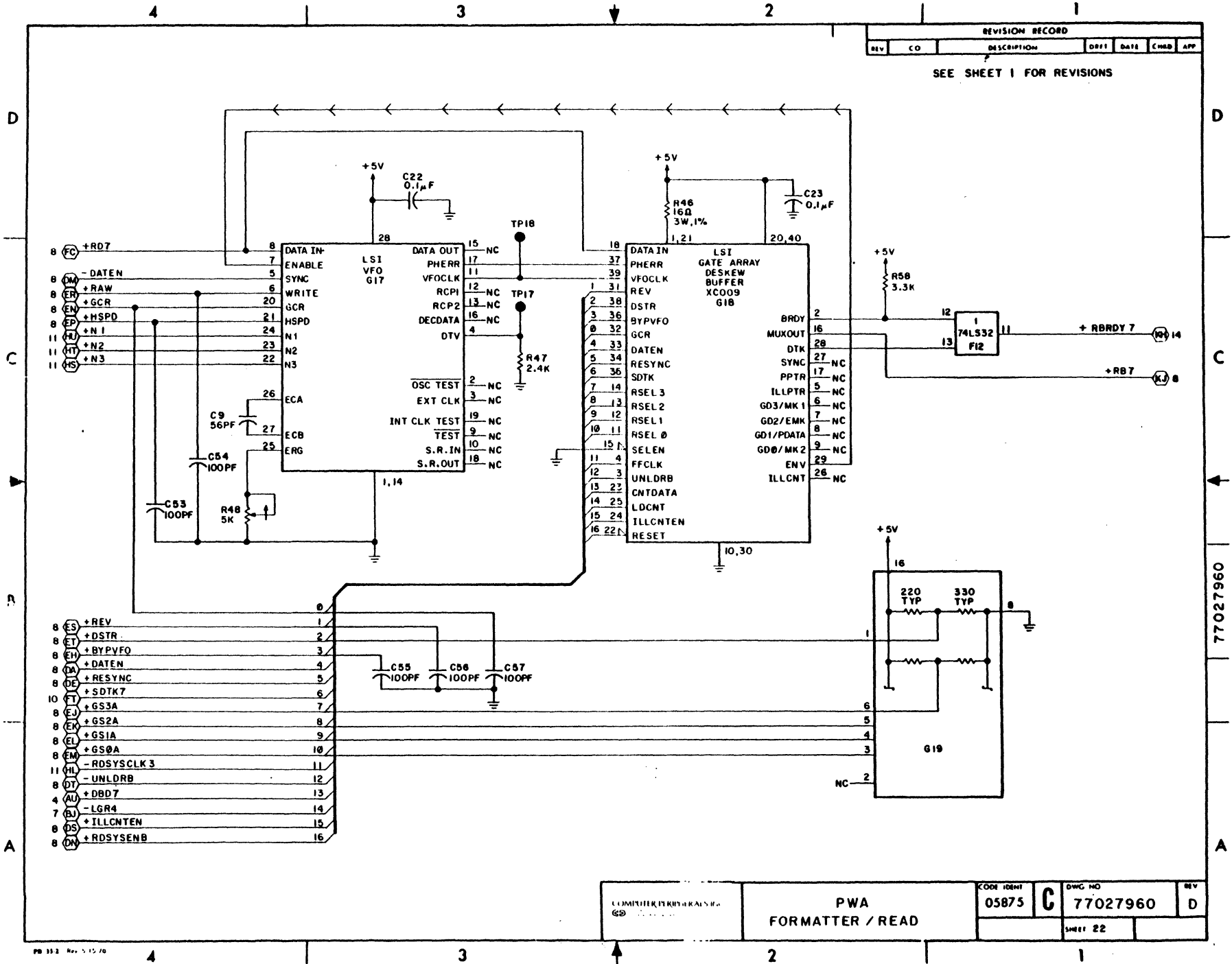

REVISION RECORD						
REV	CO	DESCRIPTION	DRFT	DATE	CHG	APP

SEE SHEET 1 FOR REVISIONS

77027960

COMPUTER RESEARCH CORPORATION	PWA FORMATTER / READ	CODE IDENT	DWG NO	REV
		05875	C 77027960	D
		SHEET 22		

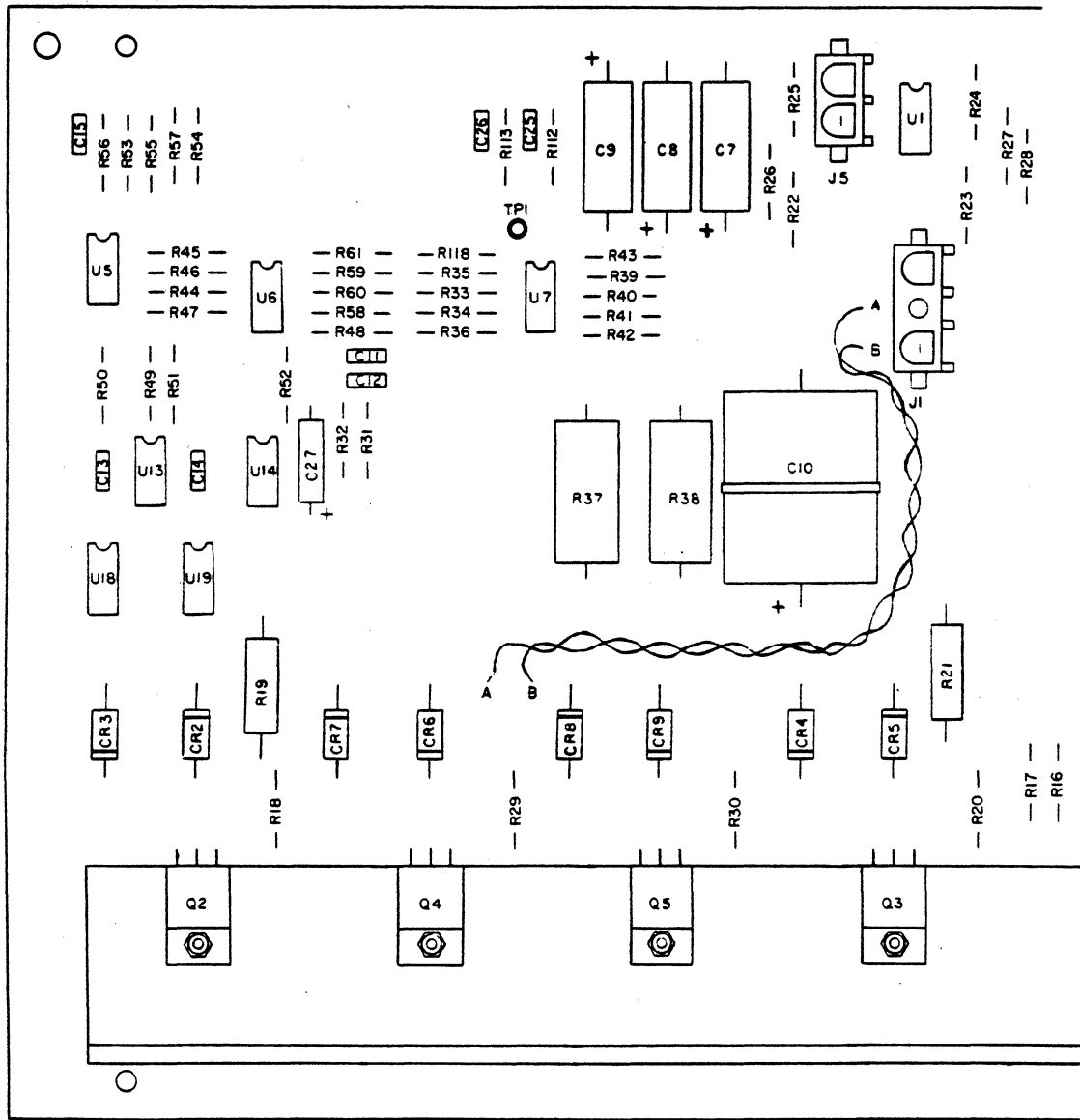

POWER DRIVER PWA 77041190

SHEET 1B



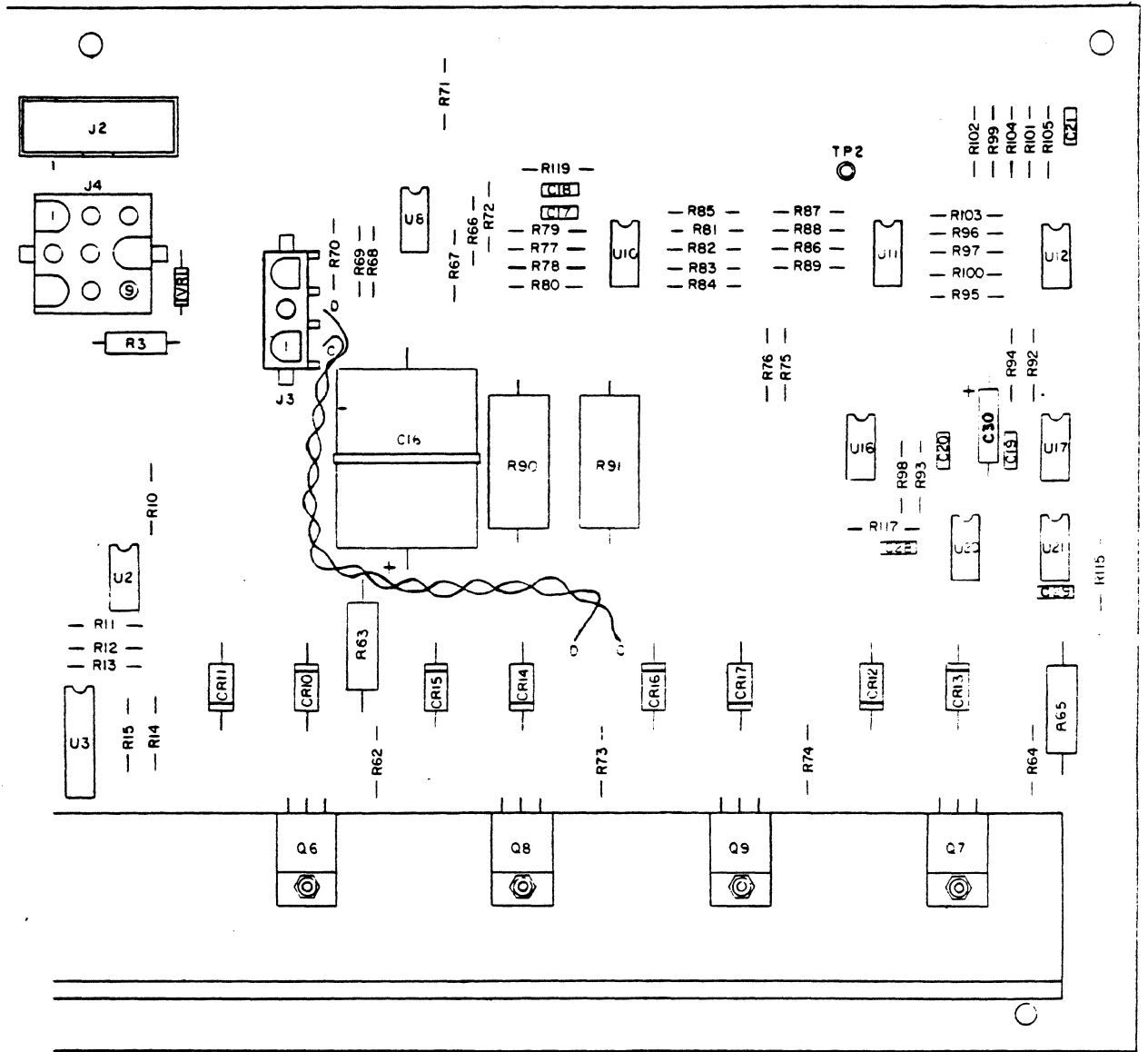

POWER DRIVER PWA

77041190

SHEET 1A

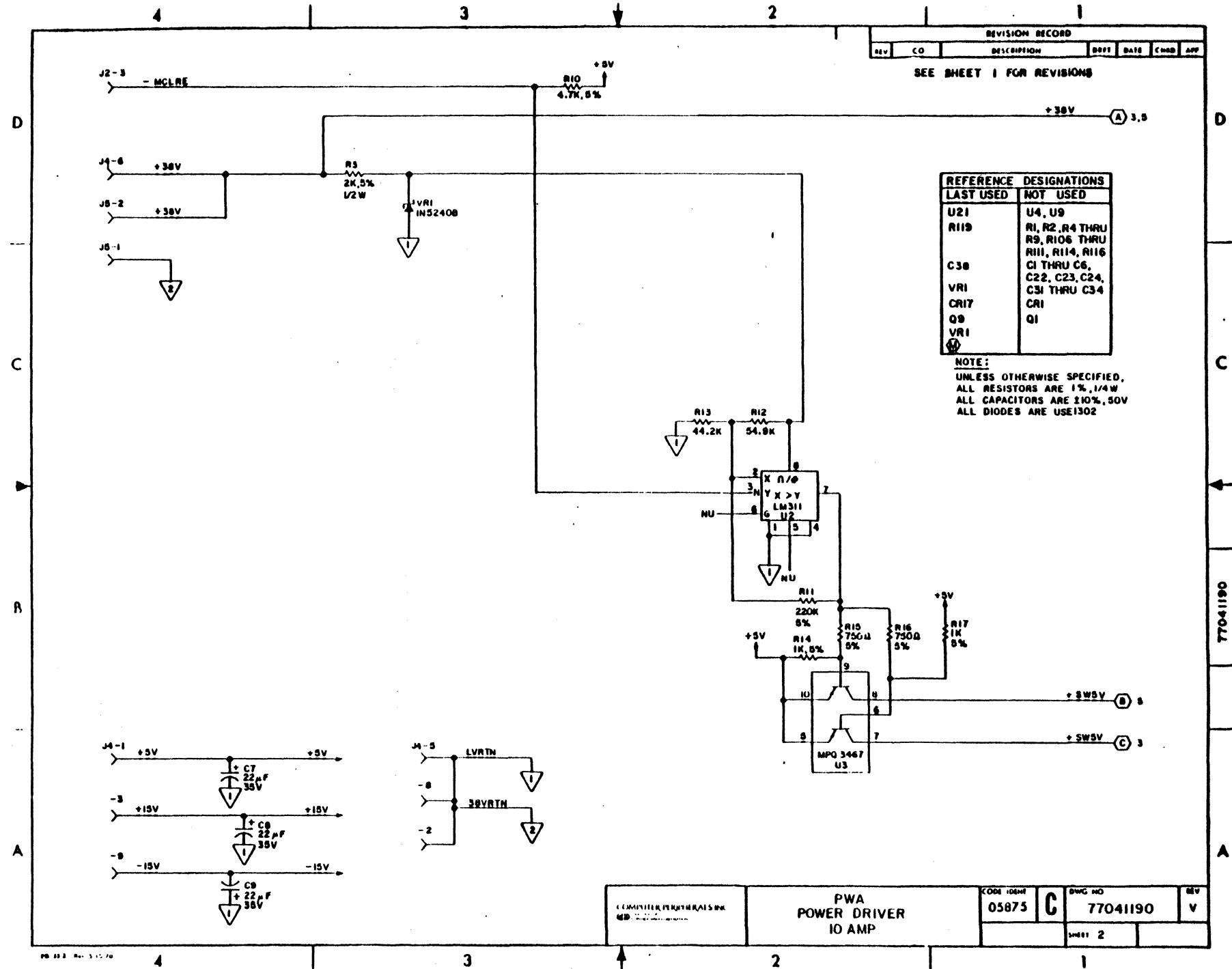

REVISION RECORD						
REV	CO	DESCRIPTION	BY	DATE	CHKD	APP
SEE SHEET 1 FOR REVISIONS						

REFERENCE DESIGNATIONS	
LAST USED	NOT USED
U21	U4, U9
R119	R1, R2, R4 THRU R9, R106 THRU R111, R114, R116
C38	C1 THRU C6, C22, C23, C24, C31 THRU C34
VRI	CRI
CR17	Q1
Q8	Q1
VRI	Q1

NOTE:  
UNLESS OTHERWISE SPECIFIED,  
ALL RESISTORS ARE 1%, 1/4W  
ALL CAPACITORS ARE 10%, 50V  
ALL DIODES ARE USE1302

COMPUTER PERIPHERALS DIV.	PWA POWER DRIVER IO AMP	CODE 10441	05875	C	DWG NO	77041190	REV	V
					SHEET	2		

77041190

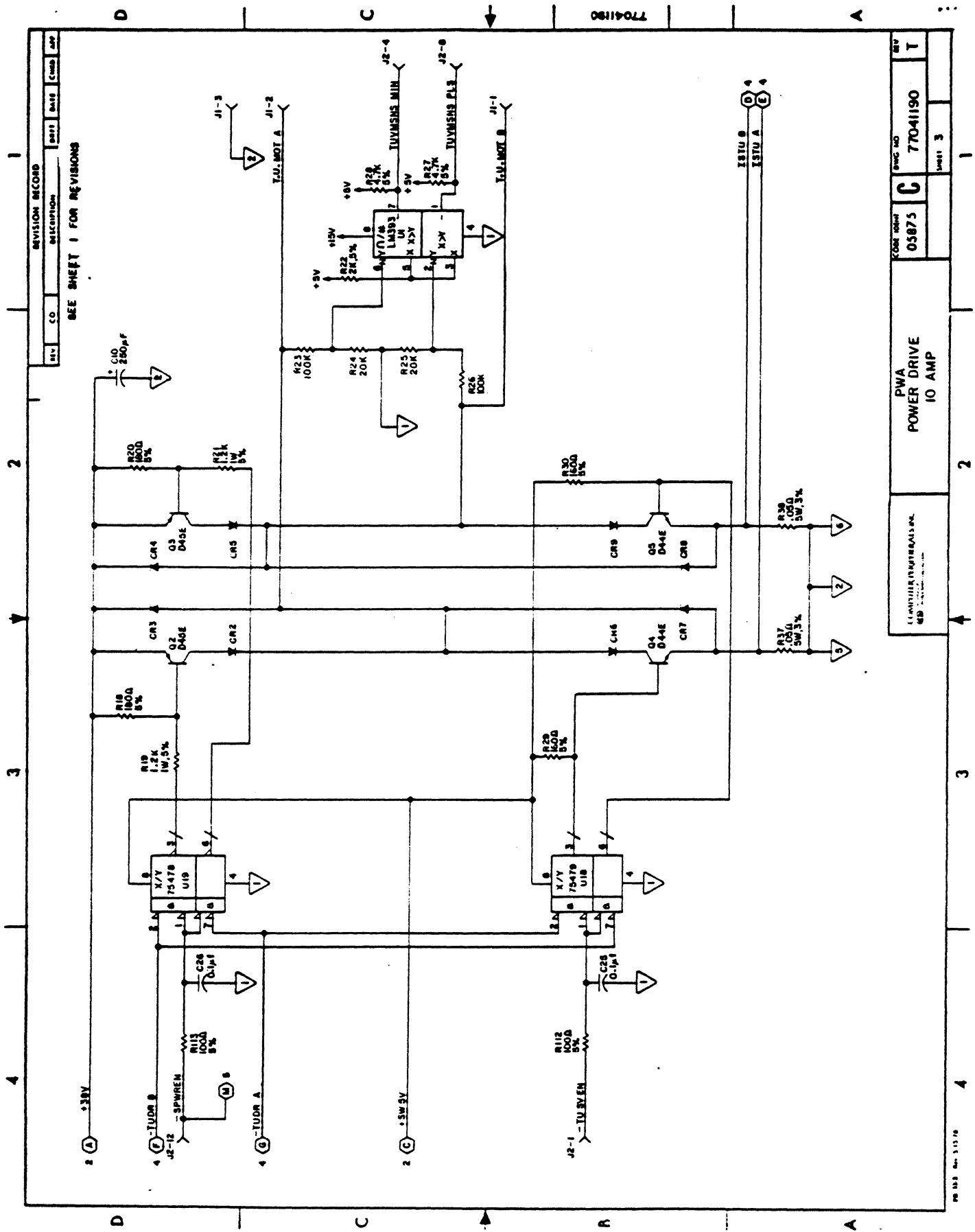

REV	T
77041190	C
05875	3
SHEET 3	

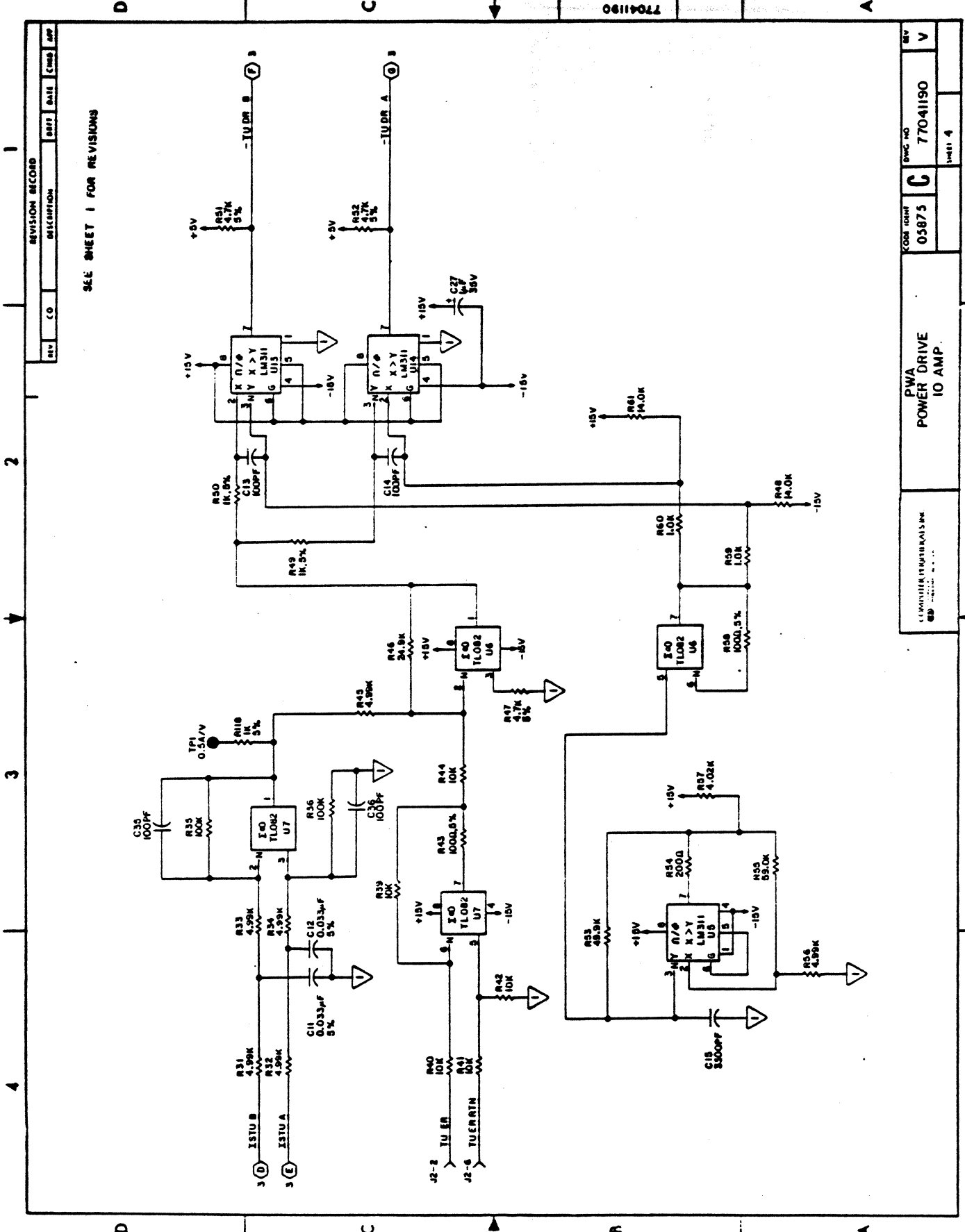

REV	CO	DESCRIPTION	DATE	BY	CHKD	APP

SEE SHEET 1 FOR REVISIONS

COMPUTER INTERNATIONAL INC			PWA POWER DRIVE IO AMP		
05875			77041190		
REV V			REV V		

49763000

5-33

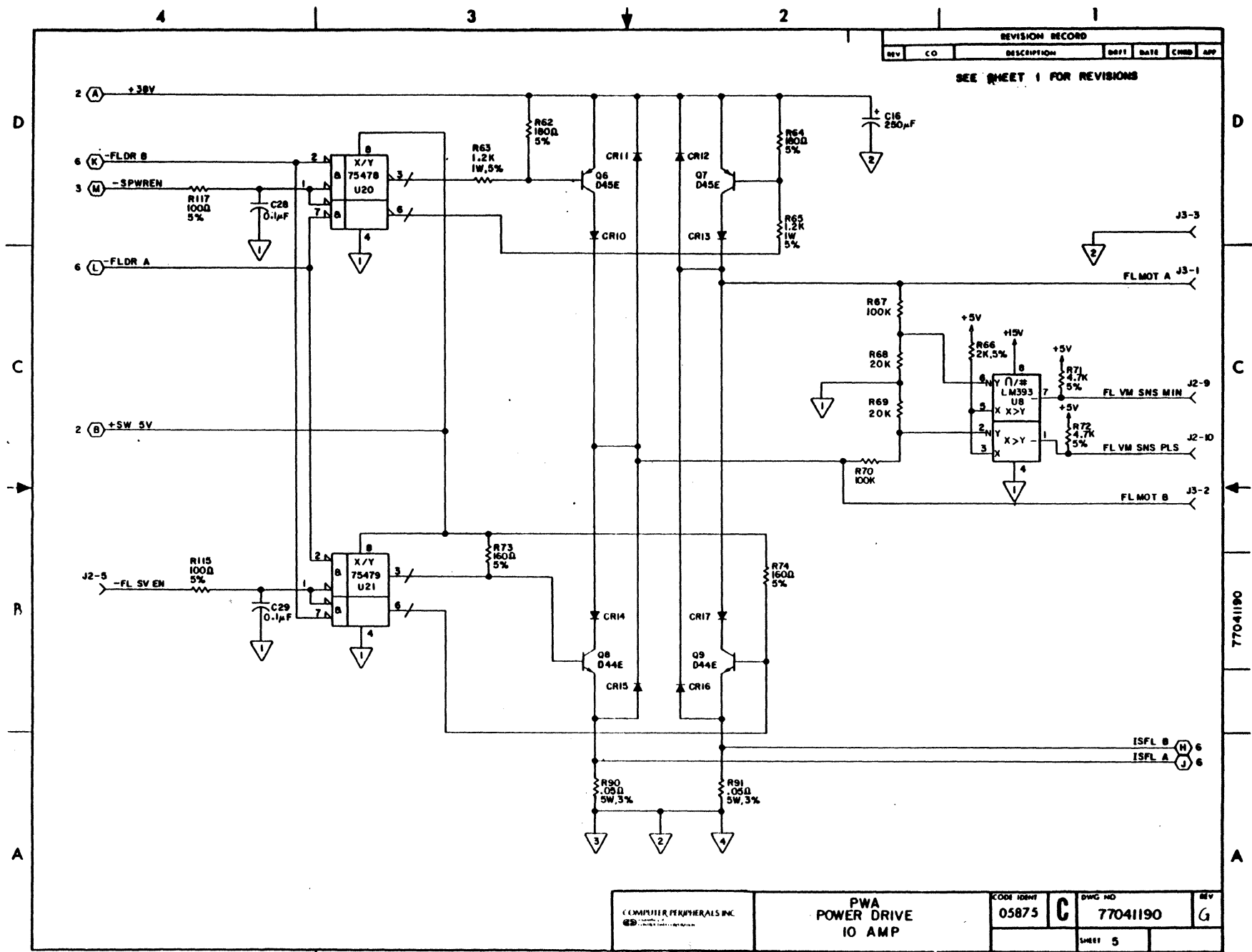

REVISION RECORD						
REV	CO	DESCRIPTION	DEPT	DATE	CHNG	APP

SEE SHEET 1 FOR REVISIONS

77041190

COMPUTER PERIPHERALS INC 69	PWA POWER DRIVE 10 AMP	CODE IDENT	DWG NO	REV
		05875	C 77041190	G
		SHEET 5		

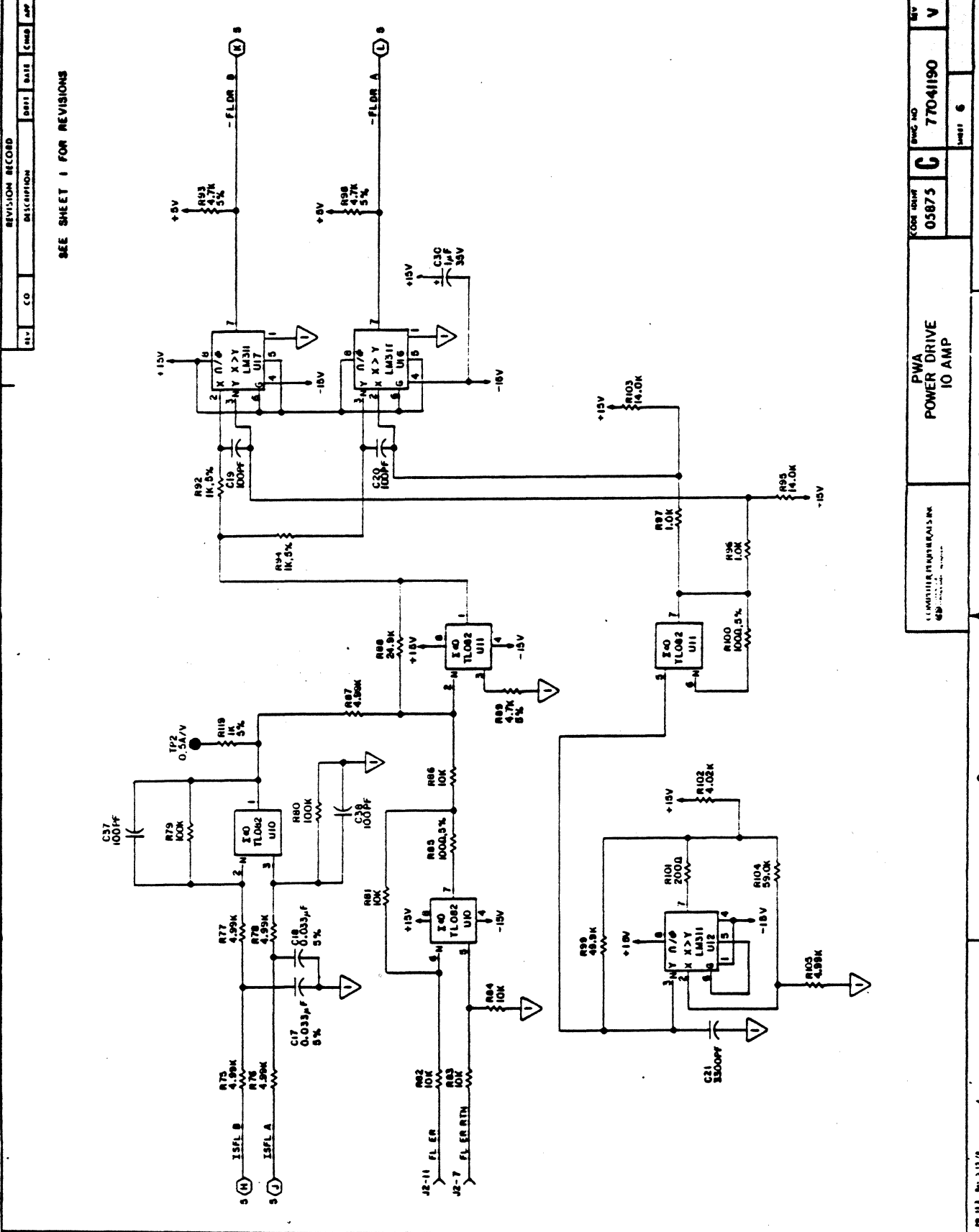

SEE SHEET 1 FOR REVISIONS

REV	CO	DESCRIPTION	DATE	CHKD	APP

PWA POWER DRIVE 10 AMP		COORDINATOR	05875	REV	6
LUMINIZER INSTRUMENTS INC		PROJECT NO	77041190	REV	1

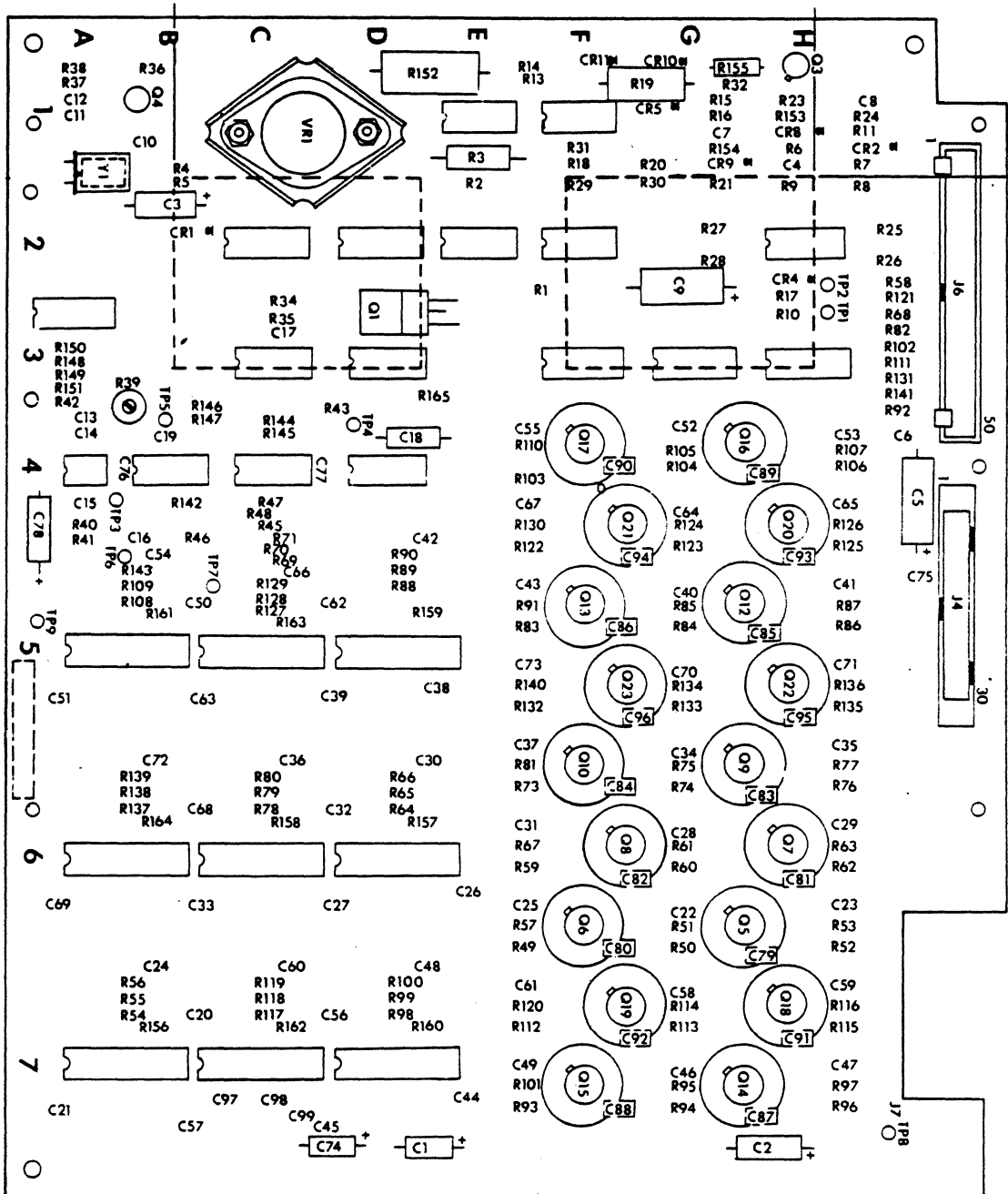

WRITE DRIVER PWA 77041210

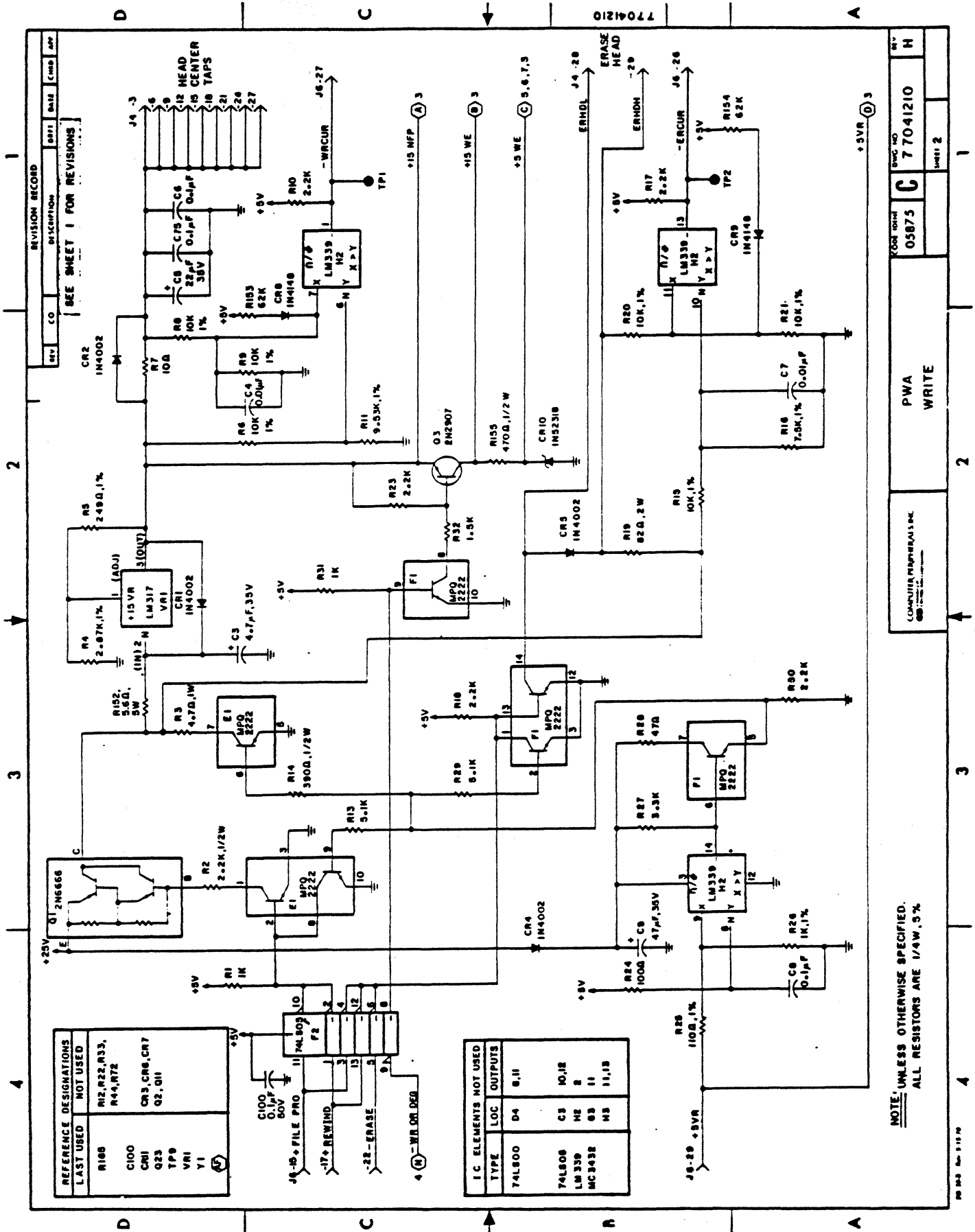

COMPUTER PERIPHERALS, INC.

PWA WRITE

FOR QUOTE 05875 C

77041210 H

Sheet 2



49763000

5-37

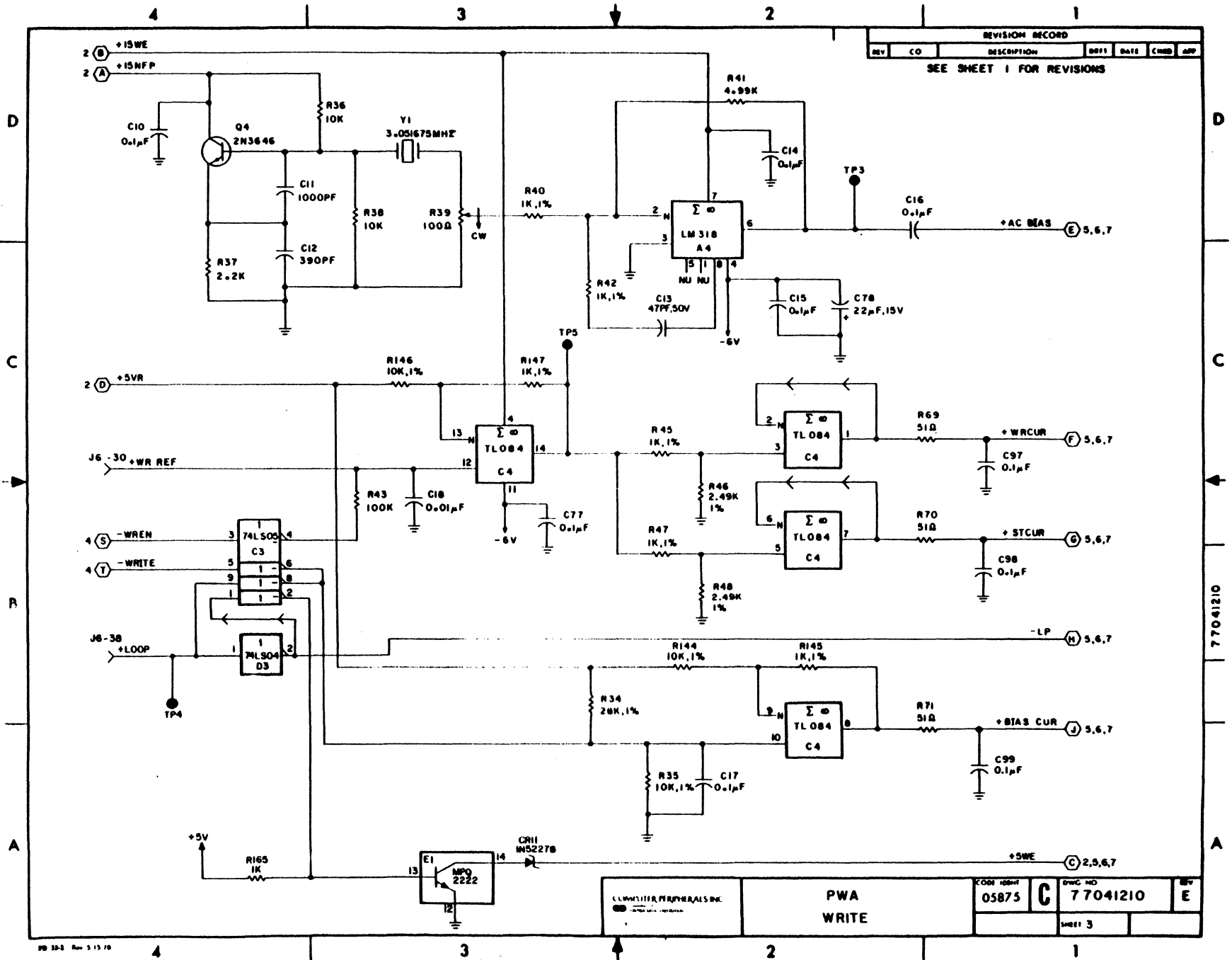

REVISION RECORD				
REV	CO	DESCRIPTION	DATE	APP
SEE SHEET 1 FOR REVISIONS				

LLWILLIET PERIPHERALS INC.		PWA WRITE		COO: 05875	DWG: 77041210	REV: E
				SHEET 3		

77041210

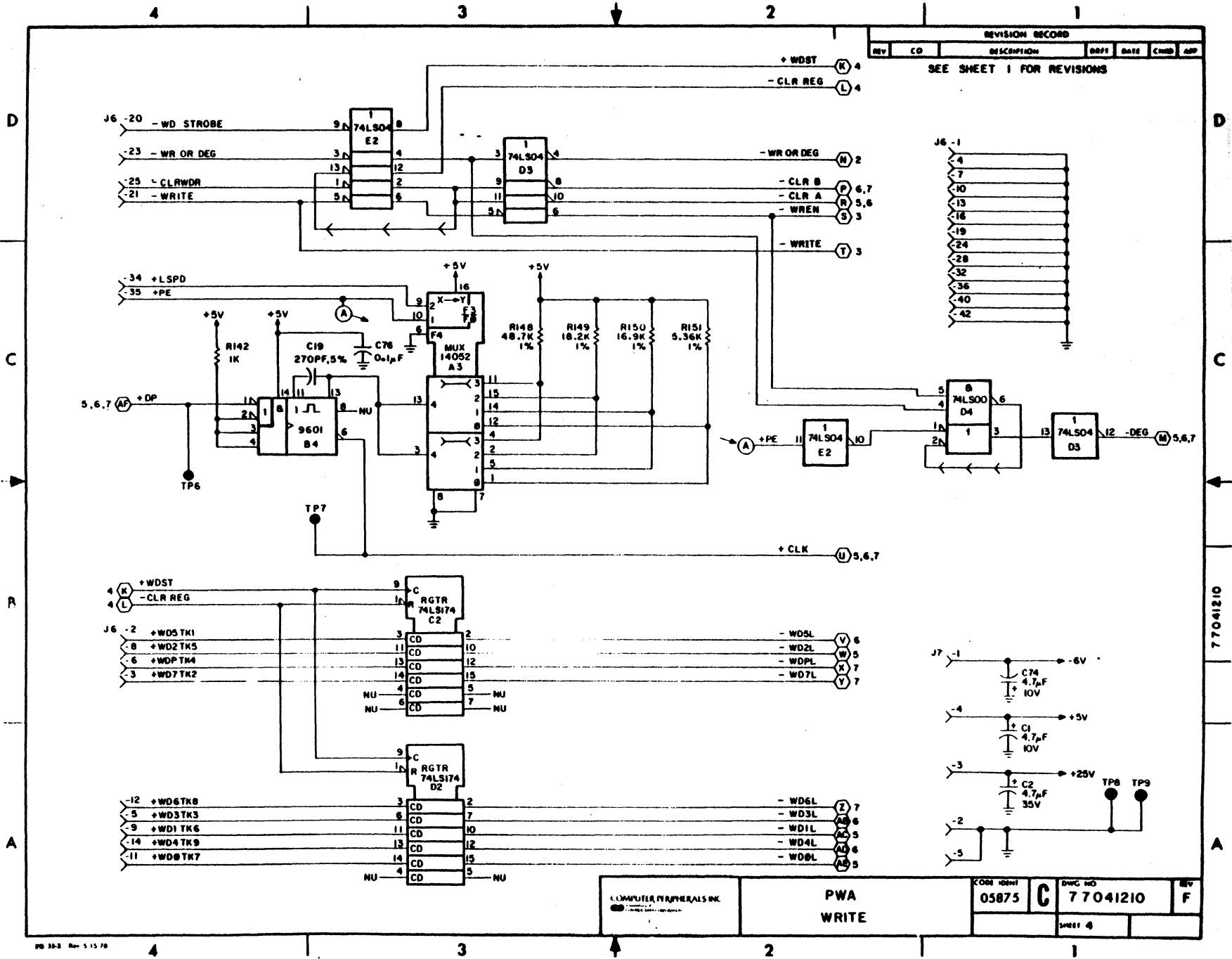

77041210

COMPUTER PERIPHERALS INC.  
 10000 WILSON BLVD.  
 FORT WORTH, TEXAS 76116

PWA  
 WRITE

CODE IDENT 05875	DRWG NO 77041210	REV F
SHEET 4		

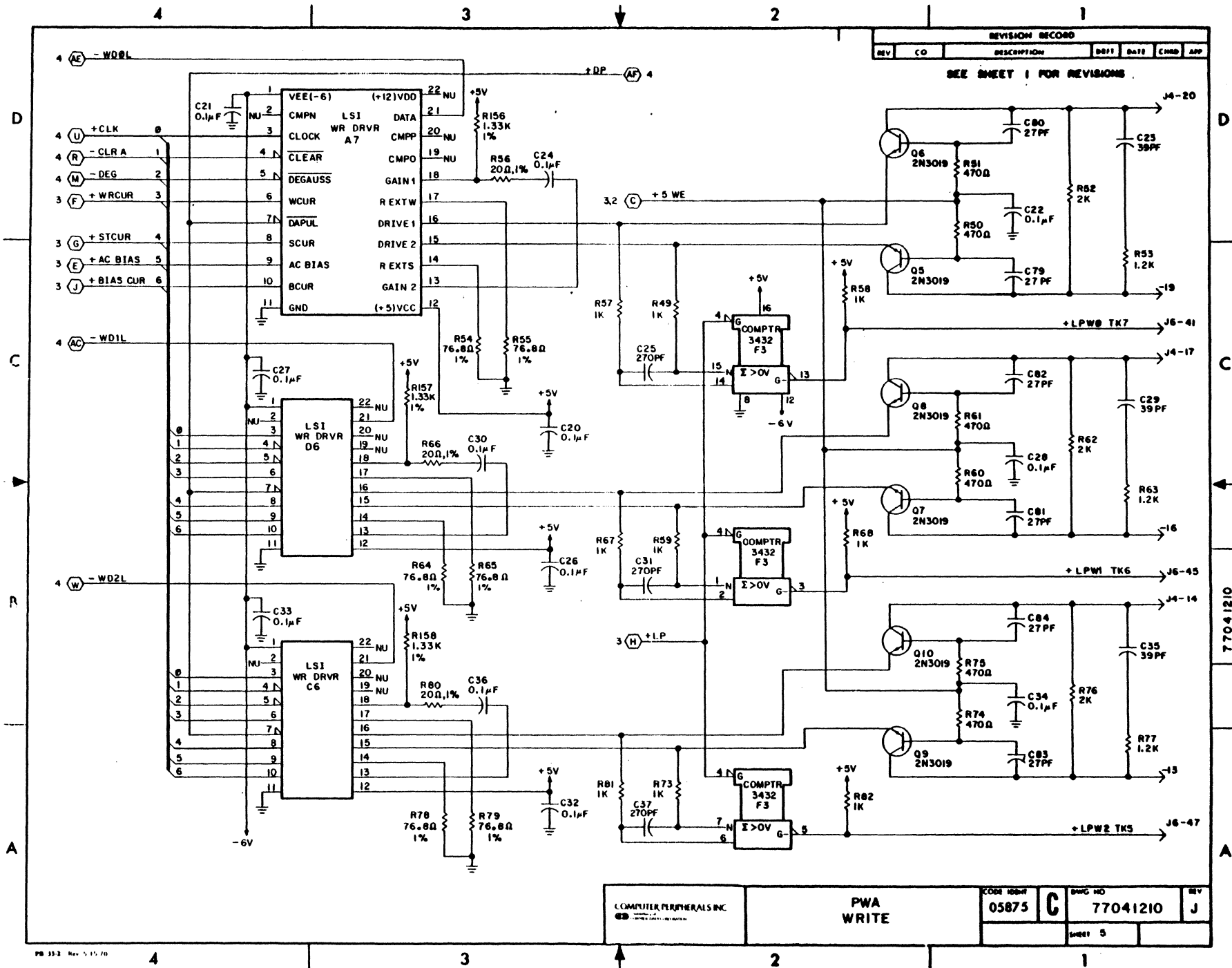

REVISION RECORD					
REV	CO	DESCRIPTION	DATE	CHKD	APP
SEE SHEET 1 FOR REVISIONS					

77041210

COMPUTER PERIPHERALS INC.	PWA WRITE	CODE 05875	DRWG NO 77041210	REV J
			SHEET 5	

S-40

49763000 K

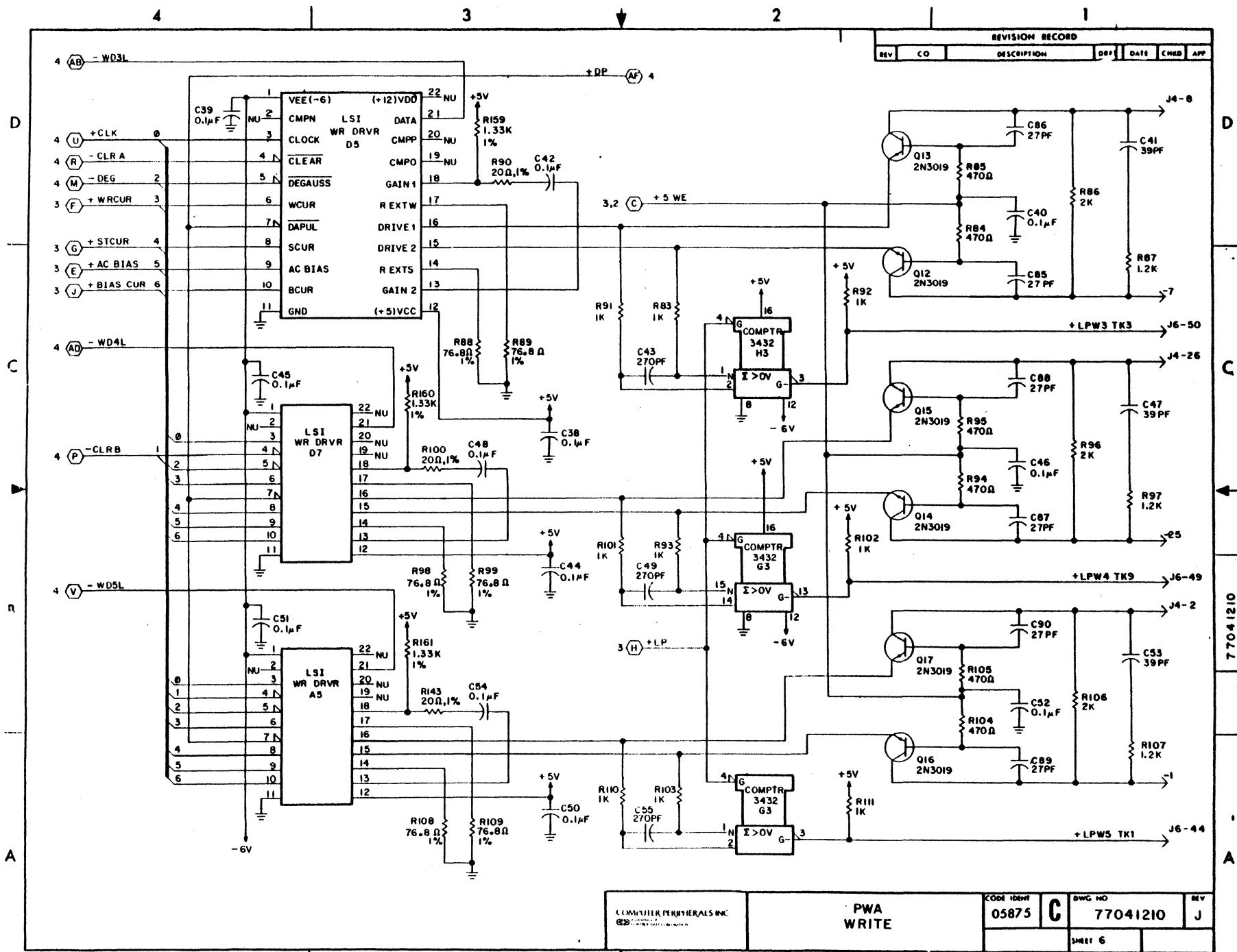

REVISION RECORD					
REV	CO	DESCRIPTION	DATE	CHNG	APP

COMPUTER PERIPHERALS INC. 620 ...	PWA WRITE	CODE IDENT 05875	DWG NO 77041210	REV J
			SHEET 6	

49763000 K

S-41

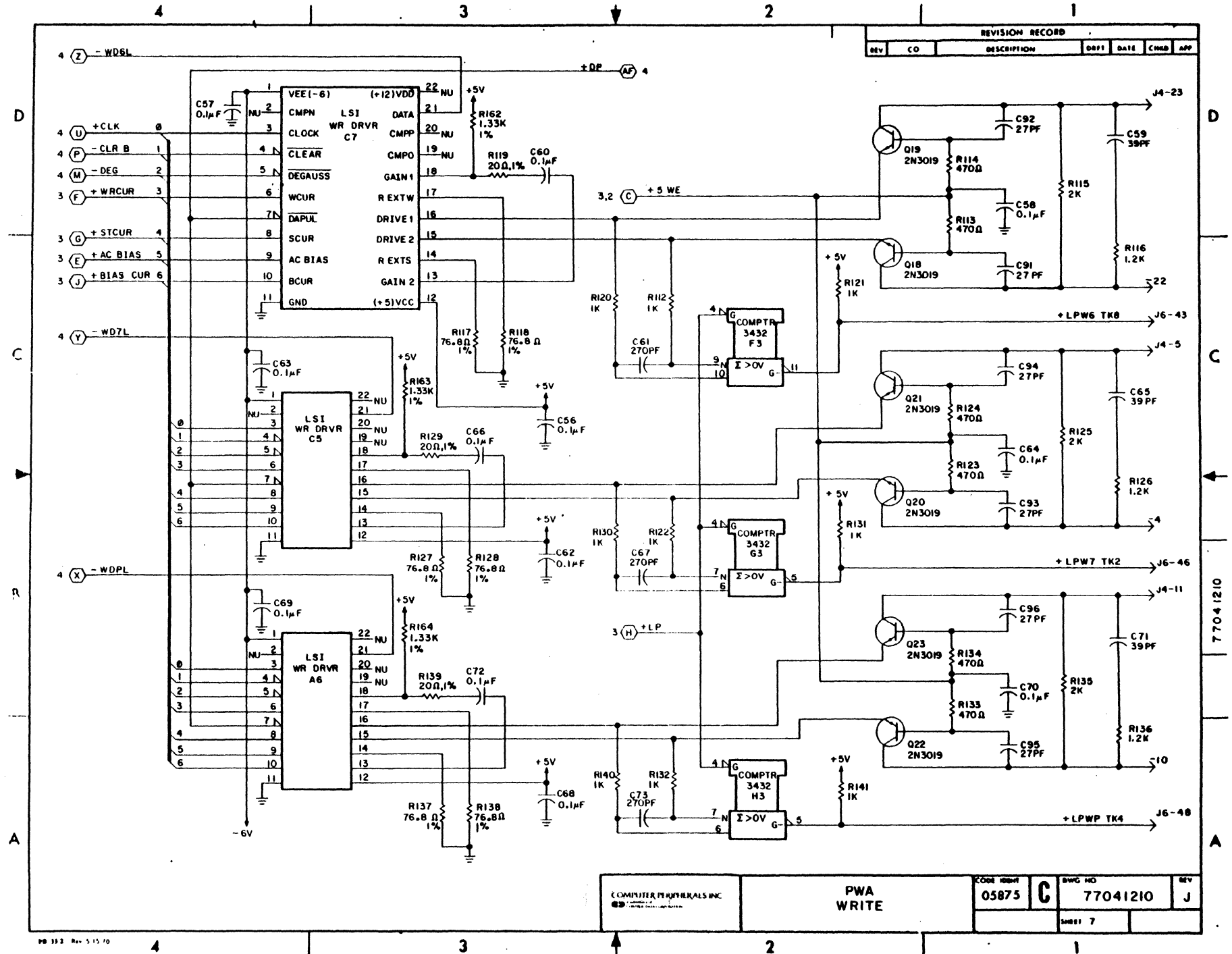

COMPTON PERIPHERALS INC.	PWA WRITE	CODE 05875	DWG NO 77041210	REV J
		C	Sheet 7	

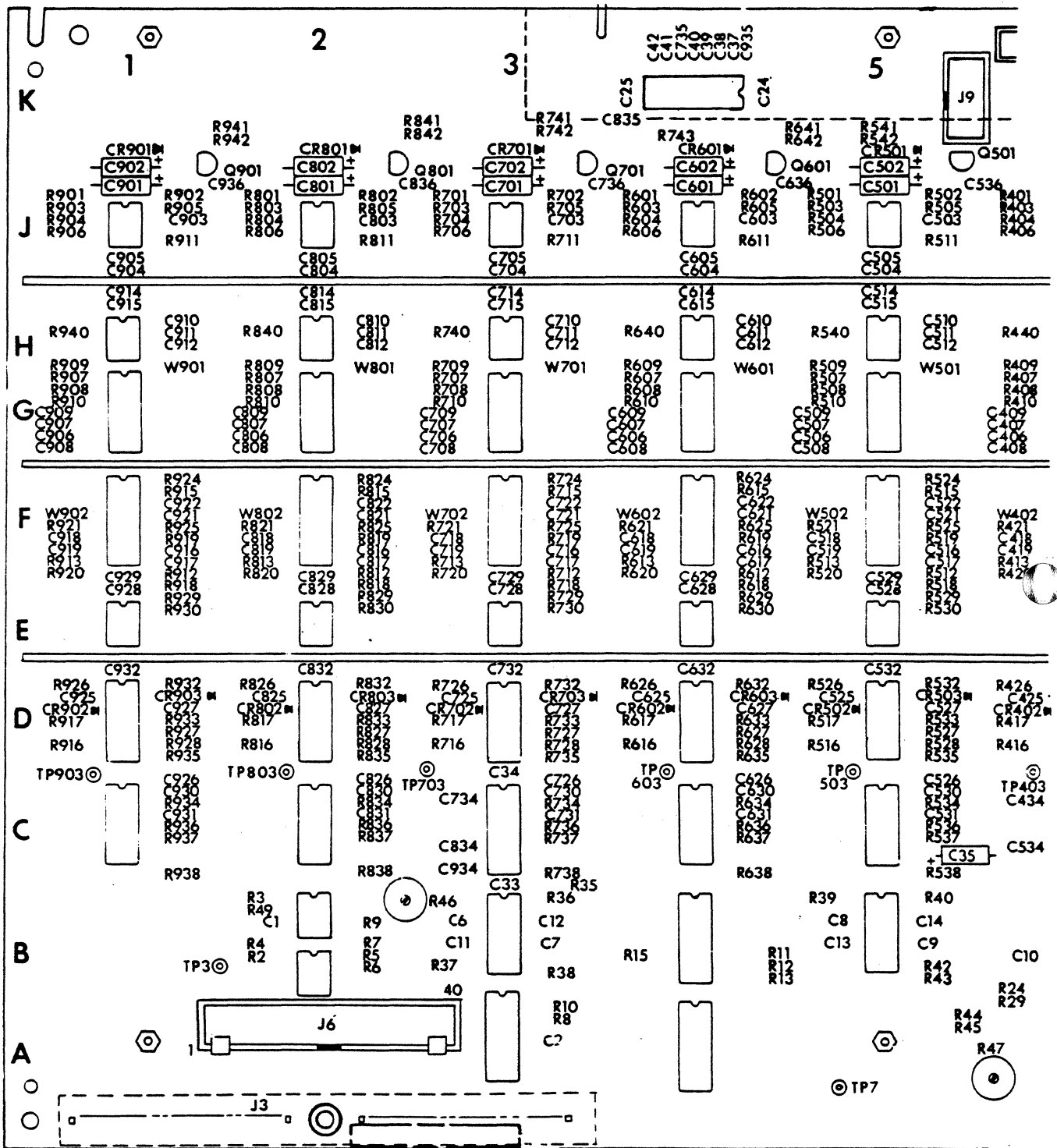

READ AMPLIFIER PWA

77041220

SHEET 1A

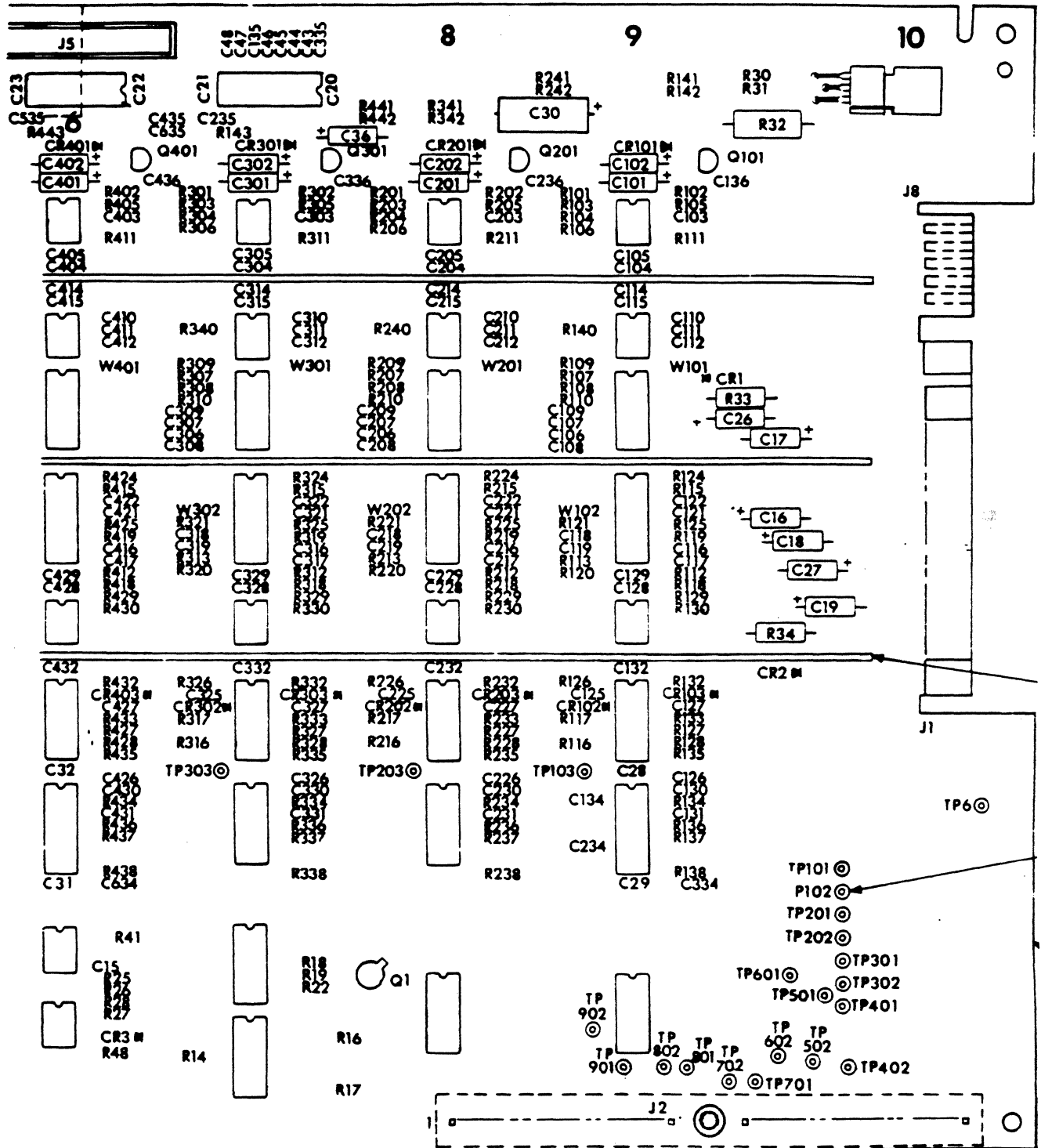

READ AMPLIFIER PWA 77041220

SHEET 1B

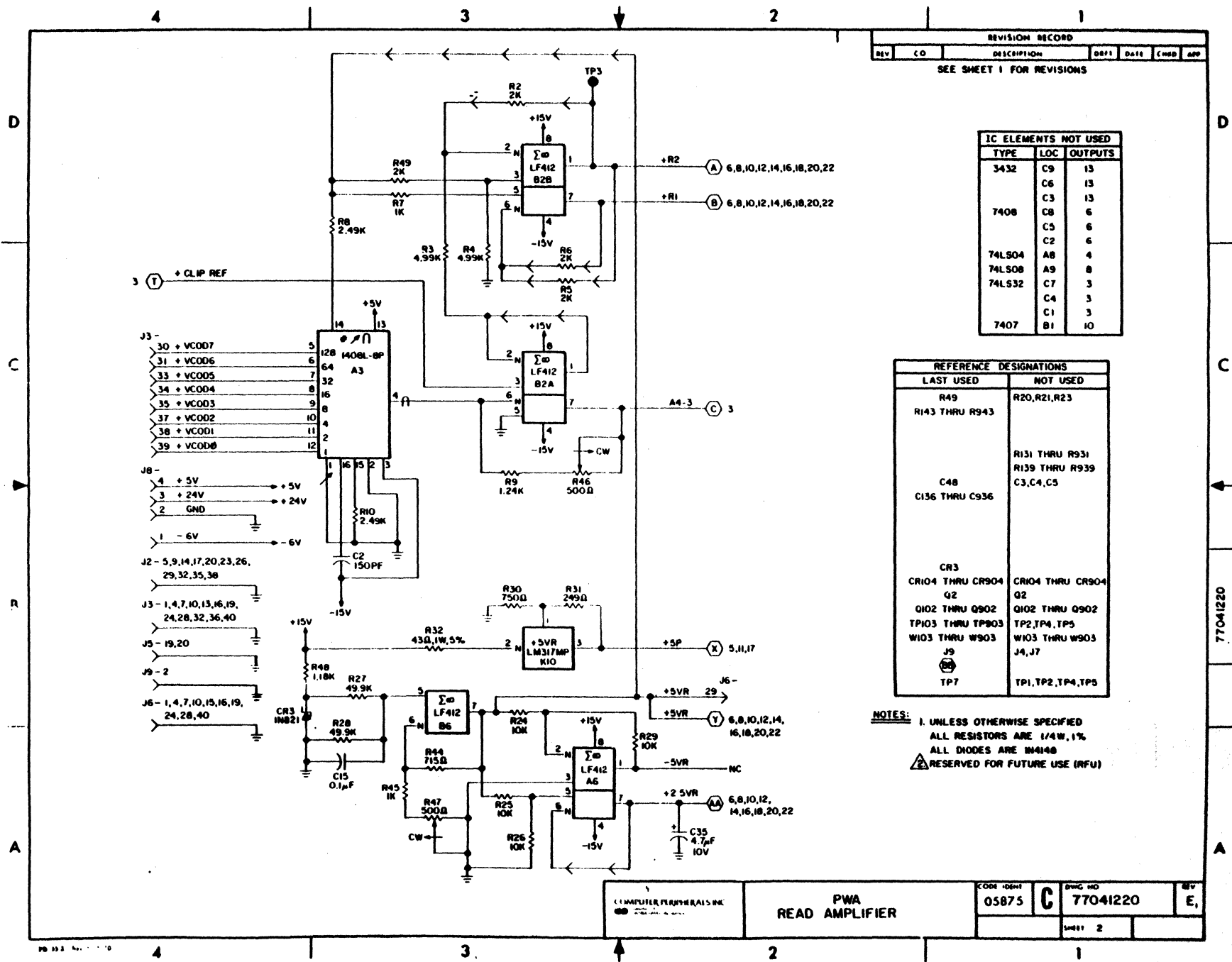

REVISION RECORD						
REV	CO	DESCRIPTION	DRFT	DATE	CHKD	APP
SEE SHEET 1 FOR REVISIONS						

IC ELEMENTS NOT USED		
TYPE	LOC	OUTPUTS
3432	C9	13
	C6	13
7408	C3	13
	C8	6
	C5	6
	C2	6
74LS04	A8	4
74LS08	A9	8
74LS32	C7	3
	C4	3
	C1	3
7407	B1	10

REFERENCE DESIGNATIONS	
LAST USED	NOT USED
R49 R143 THRU R943	R20,R21,R23
C48 C136 THRU C936	R131 THRU R931 R139 THRU R939 C3,C4,C5
CR3 CR104 THRU CR904	CR104 THRU CR904
Q2 Q102 THRU Q902	Q2 Q102 THRU Q902
TP103 THRU TP903	TP2,TP4,TP5
W103 THRU W903	W103 THRU W903
J9 TP7	J4,J7 TP1,TP2,TP4,TP5

NOTES: 1. UNLESS OTHERWISE SPECIFIED  
ALL RESISTORS ARE 1/4W, 1%  
ALL DIODES ARE IN4148  
⚠ RESERVED FOR FUTURE USE (RFU)

COMPUTER PERIPHERALS INC	PWA READ AMPLIFIER	CODE IDENT 05875	DWG NO 77041220	REV E
		SHEET 2		

77041220



49763000

S-45

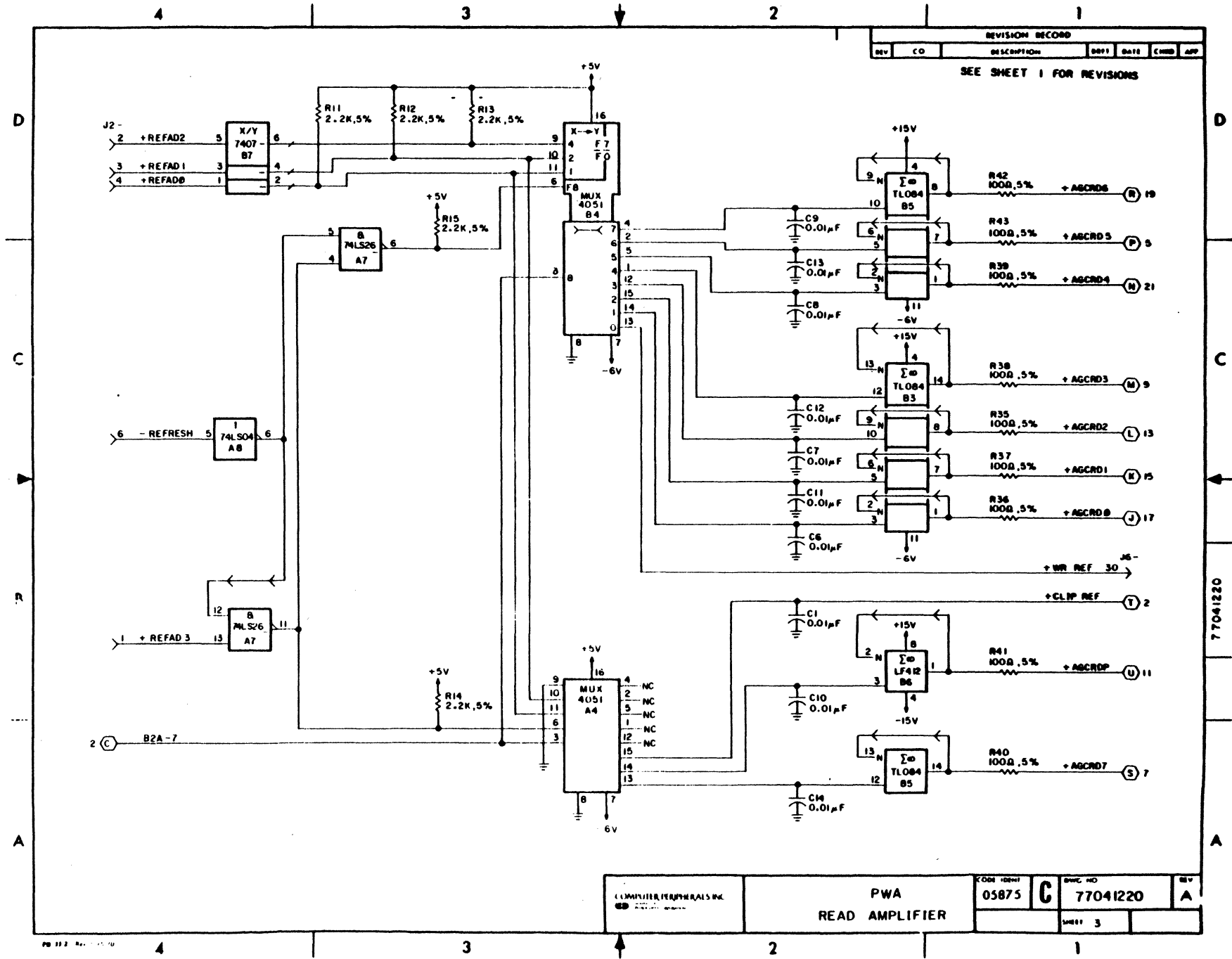

77041220

REVISION RECORD					
REV	CO	DESCRIPTION	DRFT	DATE	CHKD APP
SEE SHEET 1 FOR REVISIONS					

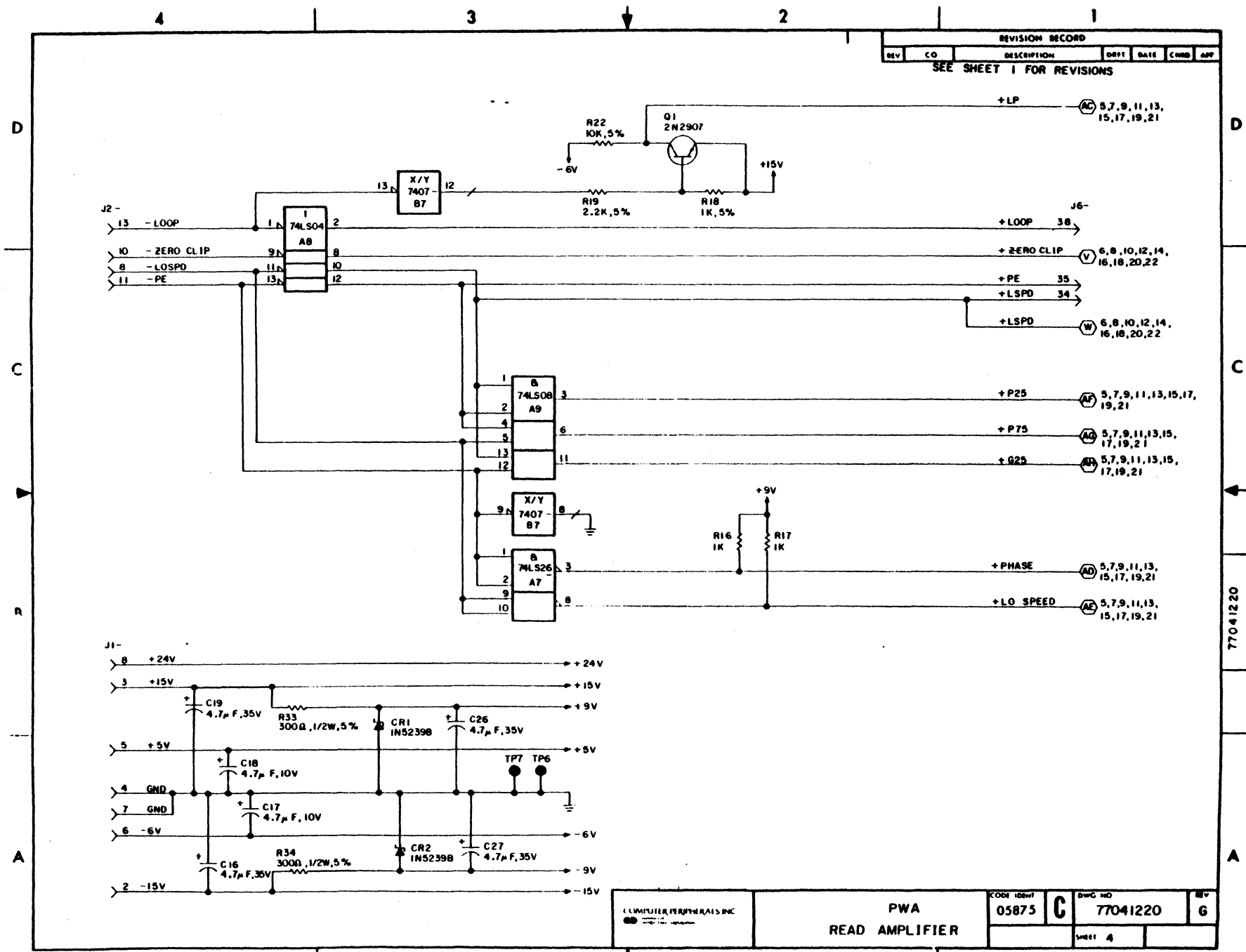

COMPUTER PERIPHERALS INC.	PWA READ AMPLIFIER	CODE IDENT	DWG NO	REV
		05875	C 77041220	6
		SHEET 4		

77041220

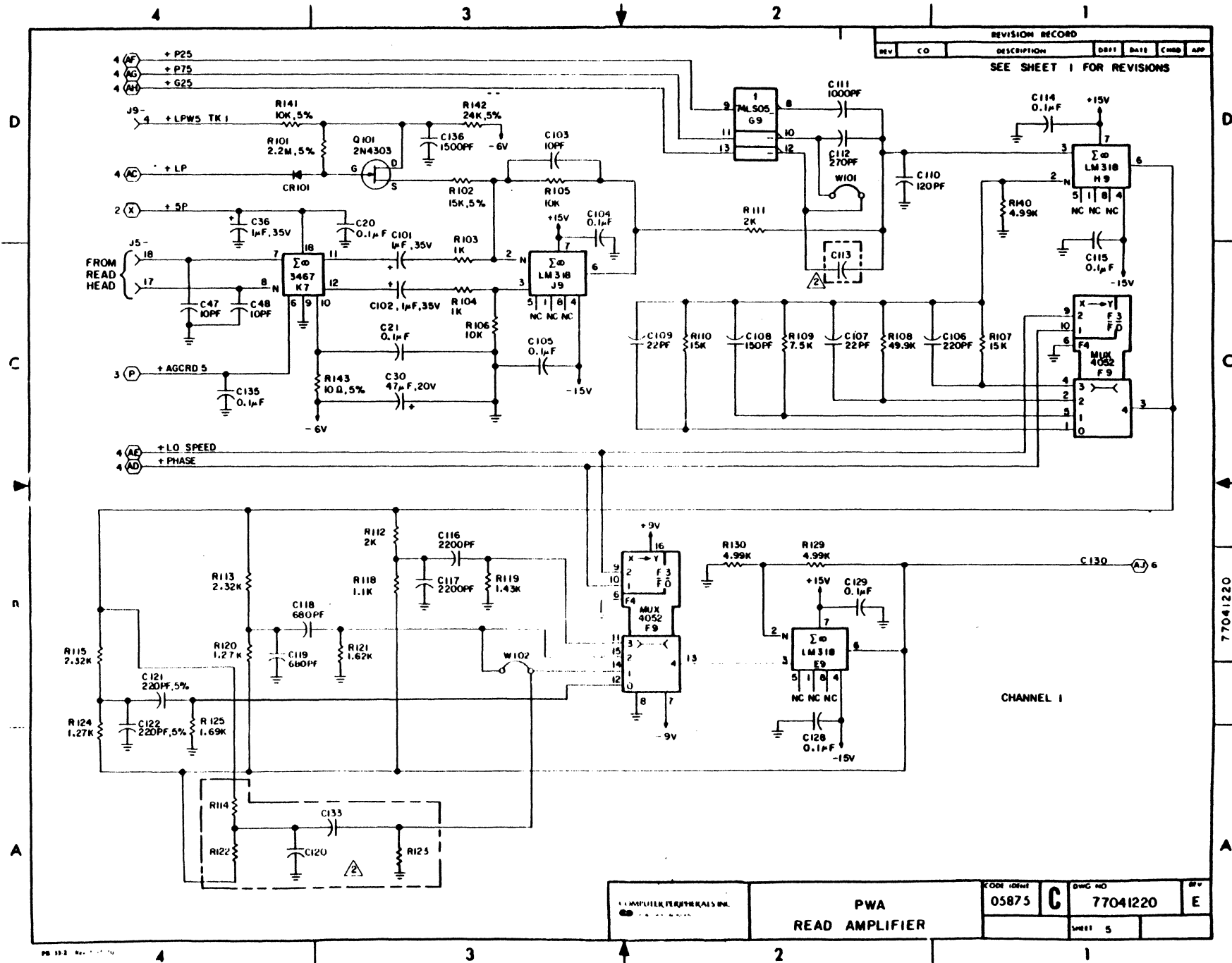

REVISION RECORD						
REV	CD	DESCRIPTION	DATE	CHKD	APP	
SEE SHEET 1 FOR REVISIONS						

CHANNEL 1

COMPUTER PERIPHERALS INC. 10000 WILSON BLVD. FORT WORTH, TEXAS 76116	<b>PWA</b>		CODE 1084	SWC NO	REV
	<b>READ AMPLIFIER</b>		05875	C 77041220	E
			SHEET 5		

REVISION RECORD					
REV	CO	DESCRIPTION	DRFI	DATE	CHKD APP
SEE SHEET 1 FOR REVISIONS					

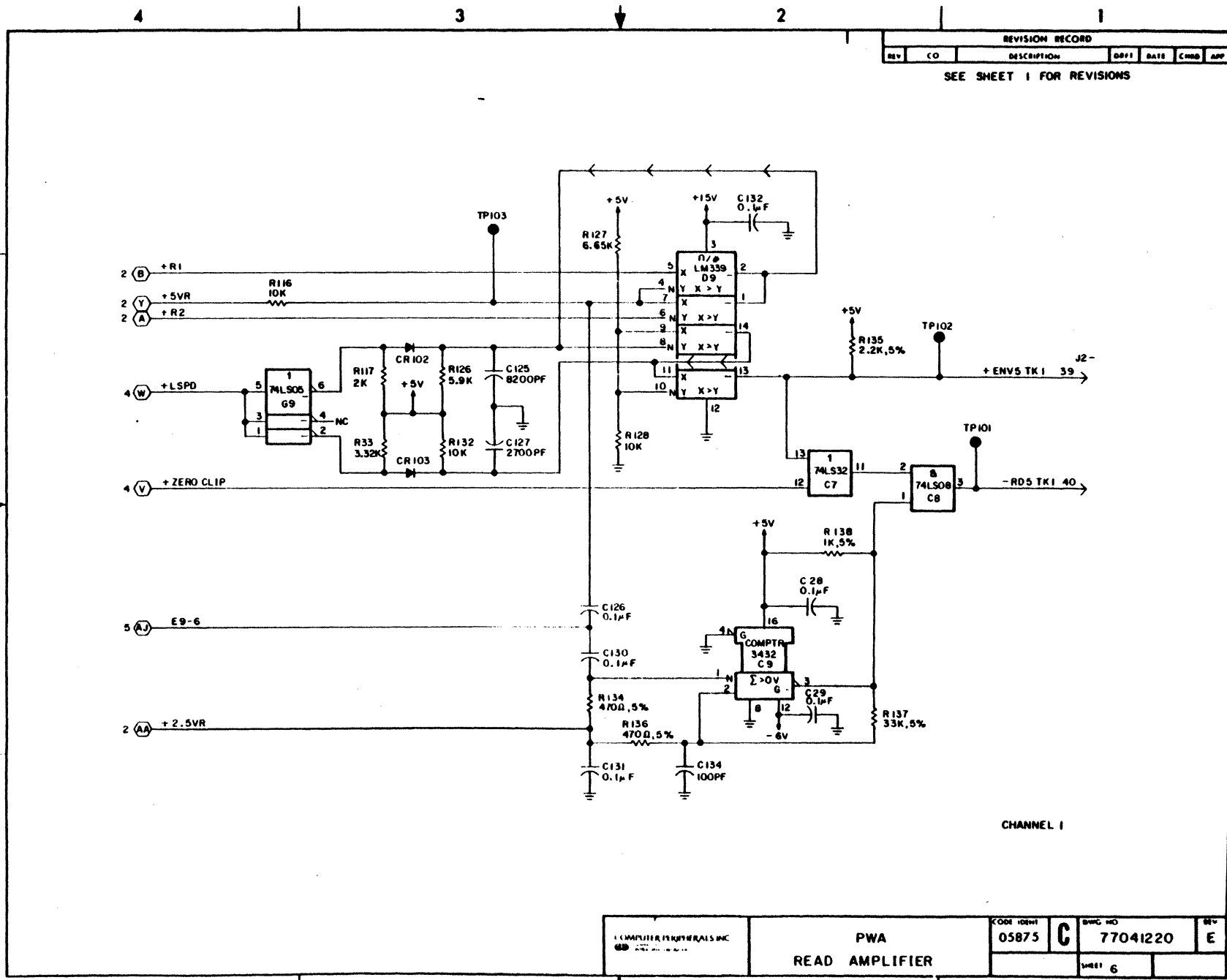

CHANNEL I

COMPUTER PERIPHERALS INC. 	<b>PWA</b> <b>READ AMPLIFIER</b>		CODE IDENT <b>05875</b>	DWG NO <b>77041220</b>	REV <b>E</b>
			SHEET 6		

77041220

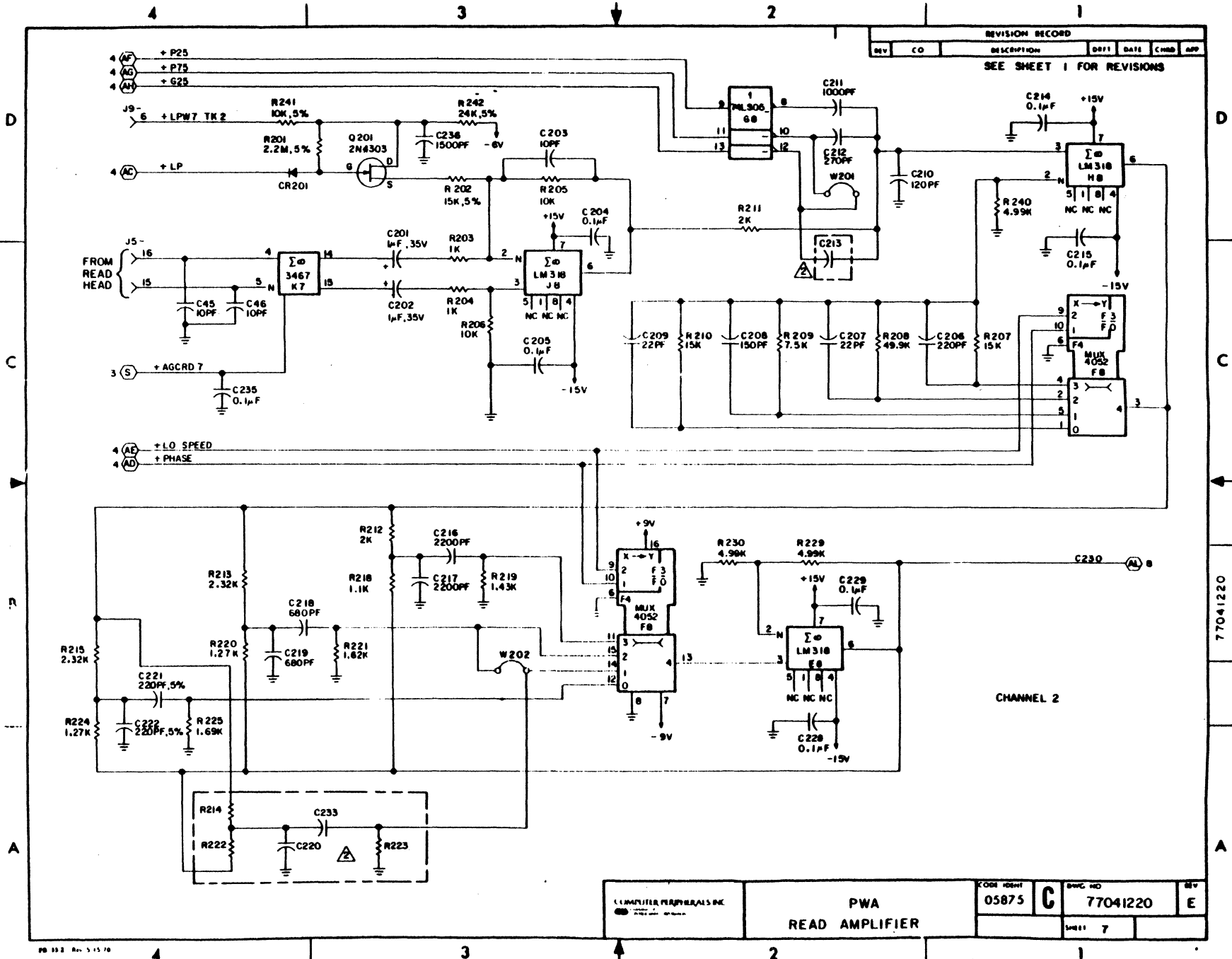

REVISION RECORD						
REV	CO	DESCRIPTION	DATE	BY	APP	
SEE SHEET 1 FOR REVISIONS						

CODE 10841	05875	Q	SWIC NO	77041220	REV	E
PWA			7			
READ AMPLIFIER						

77041220

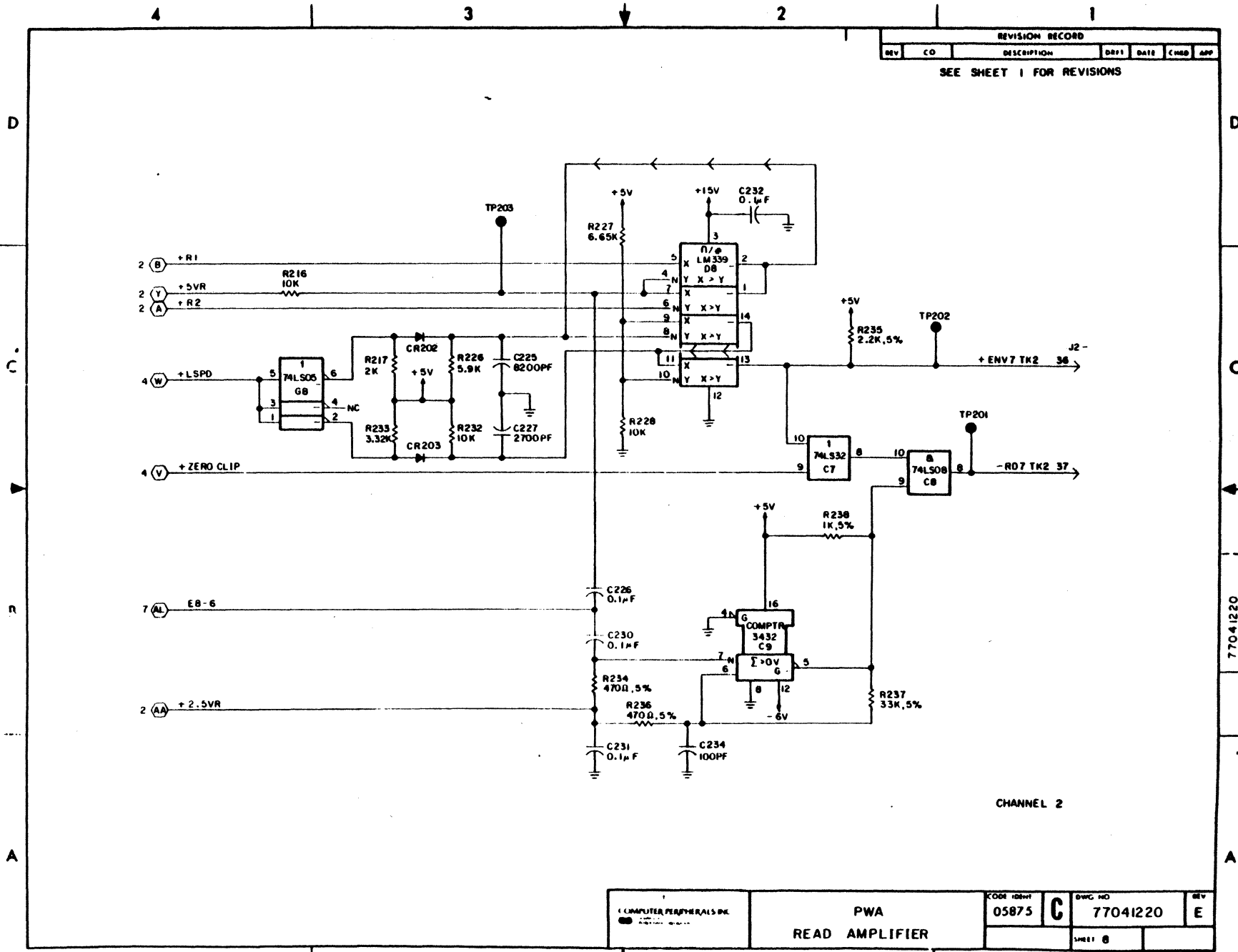

REVISION RECORD						
REV	CO	DESCRIPTION	DRN	DATE	CHKD	APP
SEE SHEET 1 FOR REVISIONS						

CHANNEL 2

COMPUTER PERIPHERALS PK. PWA READ AMPLIFIER	CODE IDENT	DWG NO	REV
	05875	C 77041220	E
SHEET 8			

77041220

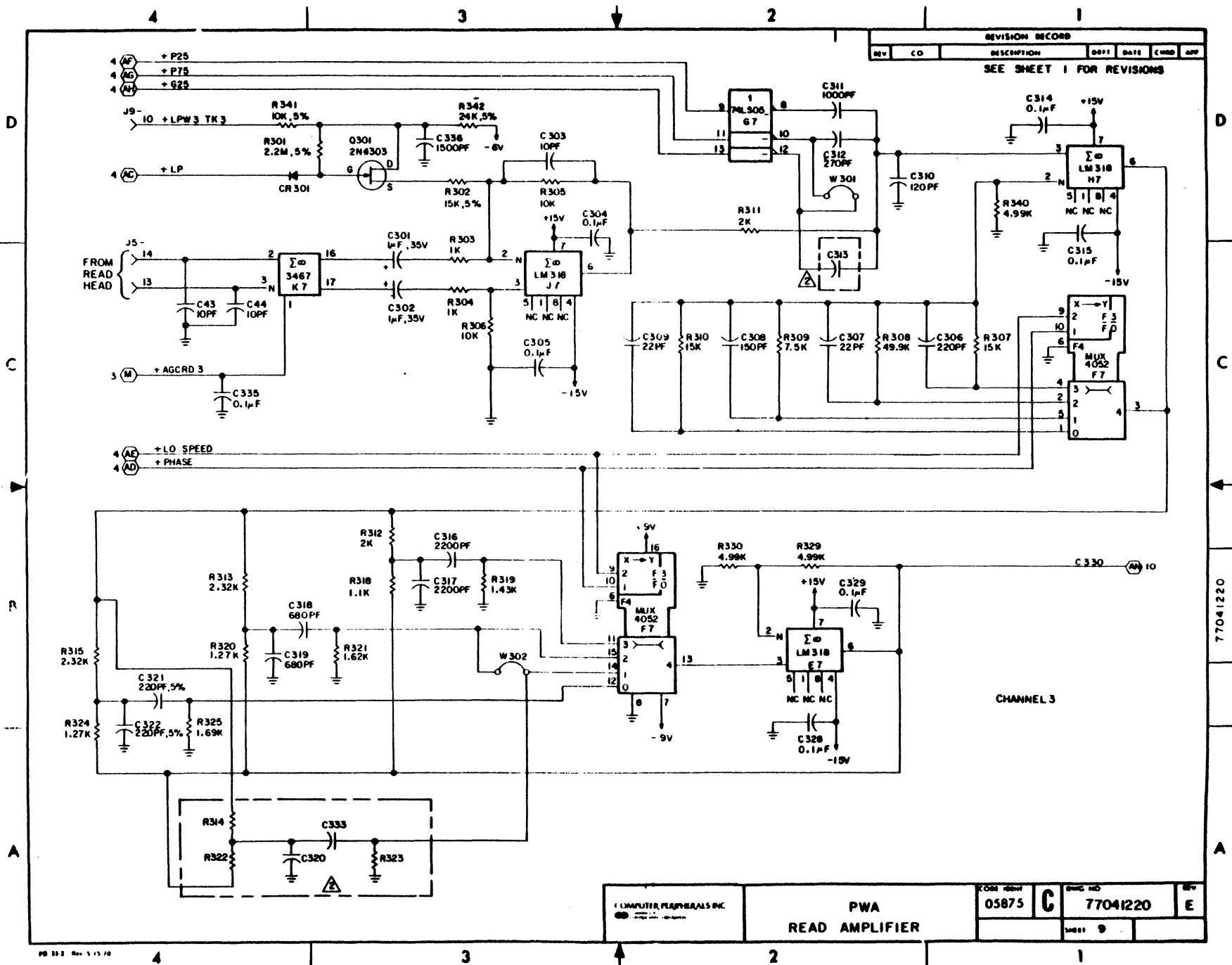

REVISION RECORD					
REV	CO	DESCRIPTION	DEPT	DATE	CHKD
SEE SHEET 1 FOR REVISIONS					

COMPUTER PERIPHERALS INC.	PWA	FORM 5875	77041220
	READ AMPLIFIER		

REVISION RECORD					
REV	CD	DESCRIPTION	DATE	CHKD	APP
SEE SHEET 1 FOR REVISIONS					

SEE SHEET 1 FOR REVISIONS

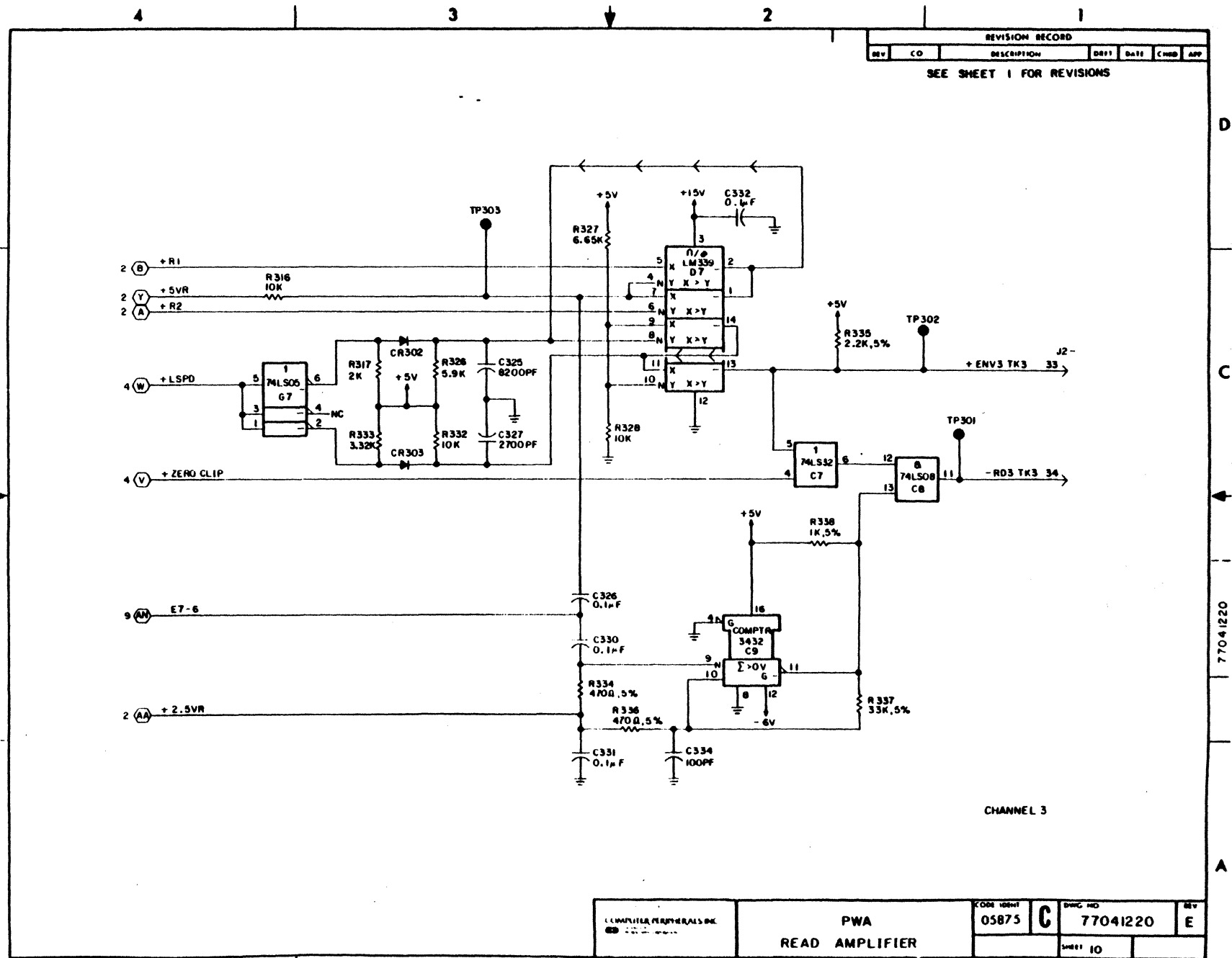

CHANNEL 3

COMM-TECH PERIPHERALS INC. 10000 W. 10th Ave. Denver, CO 80202	PWA READ AMPLIFIER		CODE IDENT 05875	DWG NO 77041220	REV E
			SHEET 10		



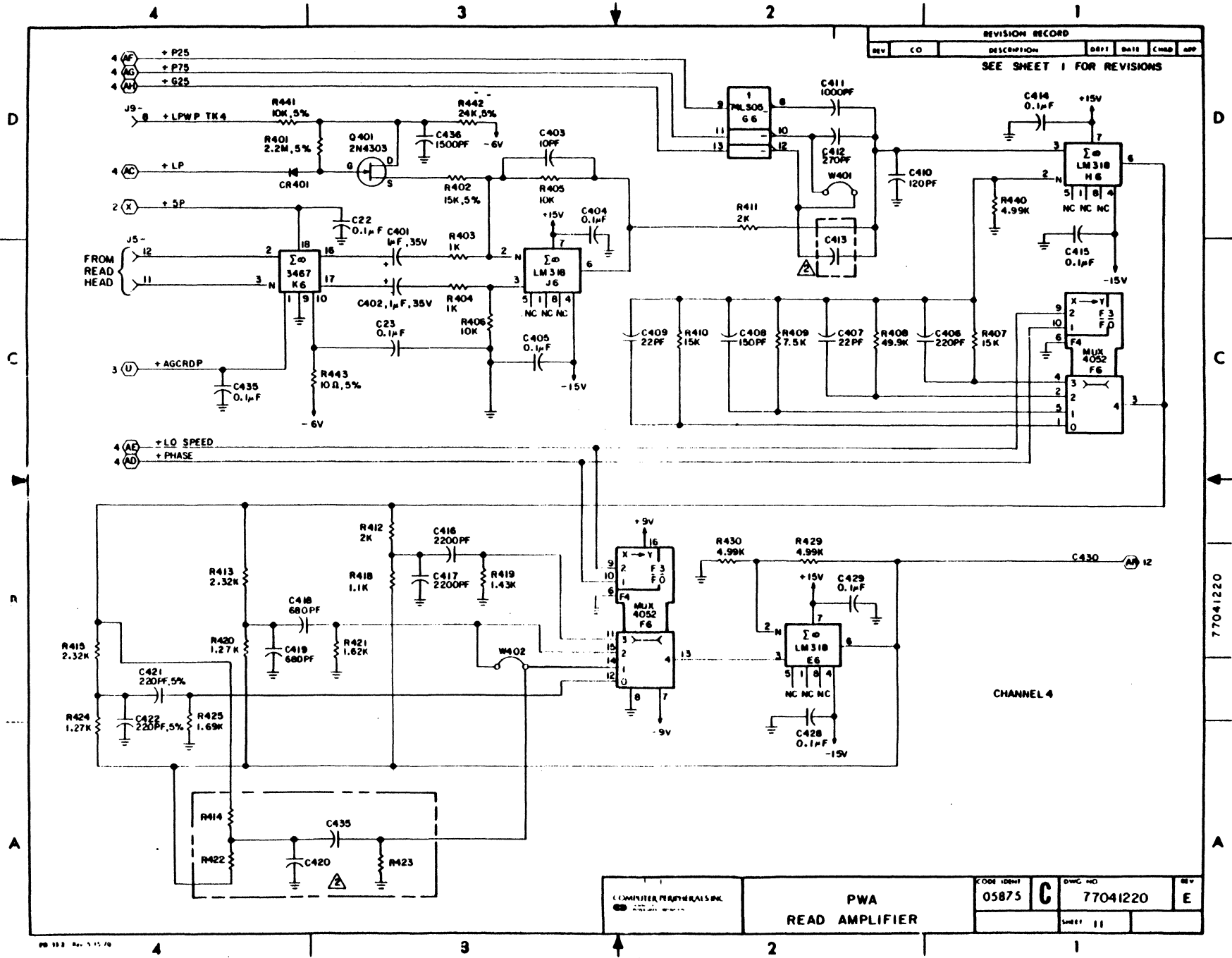

5-54

49763000 B

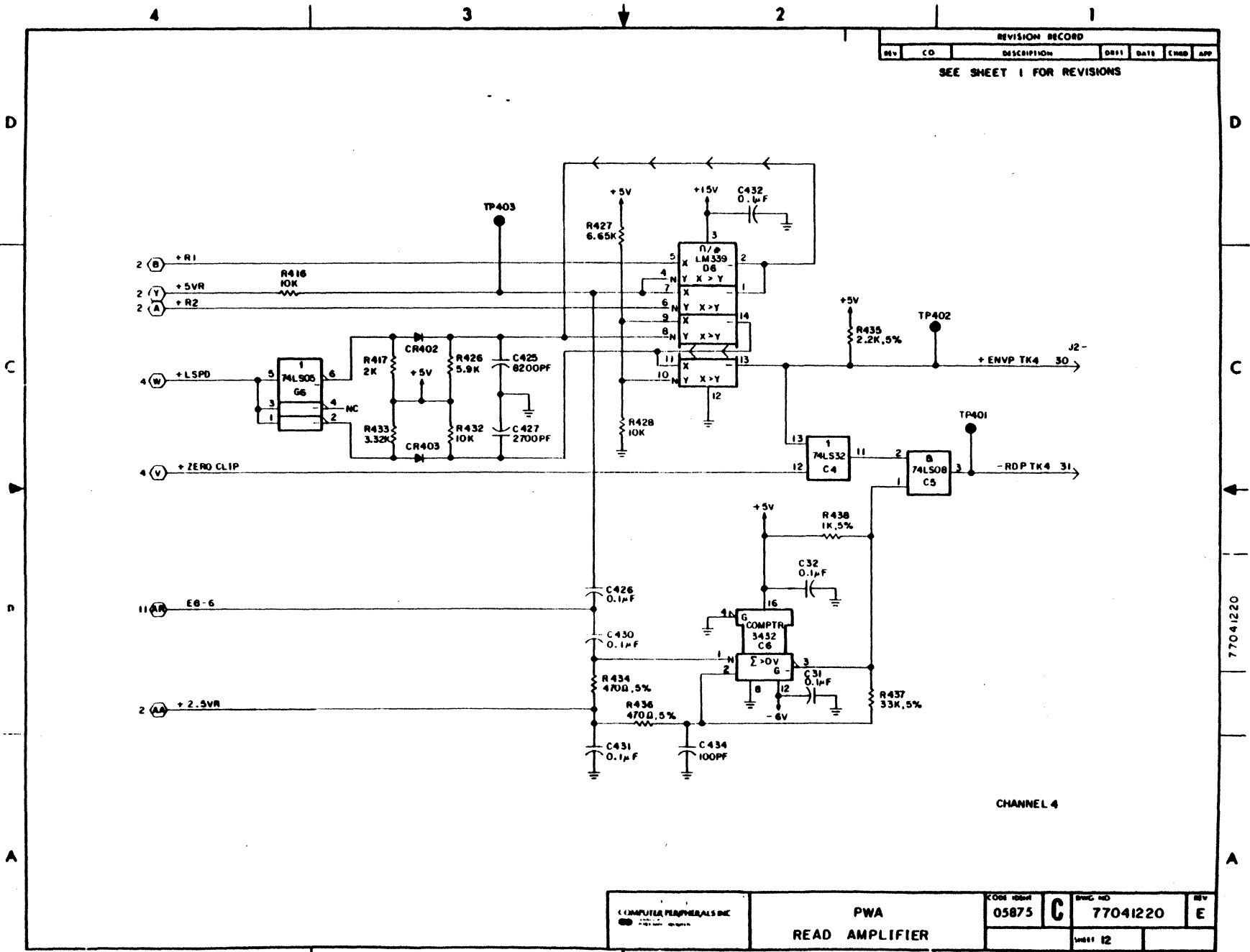

COMPUTER PERIPHERALS INC	PWA READ AMPLIFIER	CODE 1004 05875	REV. NO C 77041220	REV E
		DATE 12		

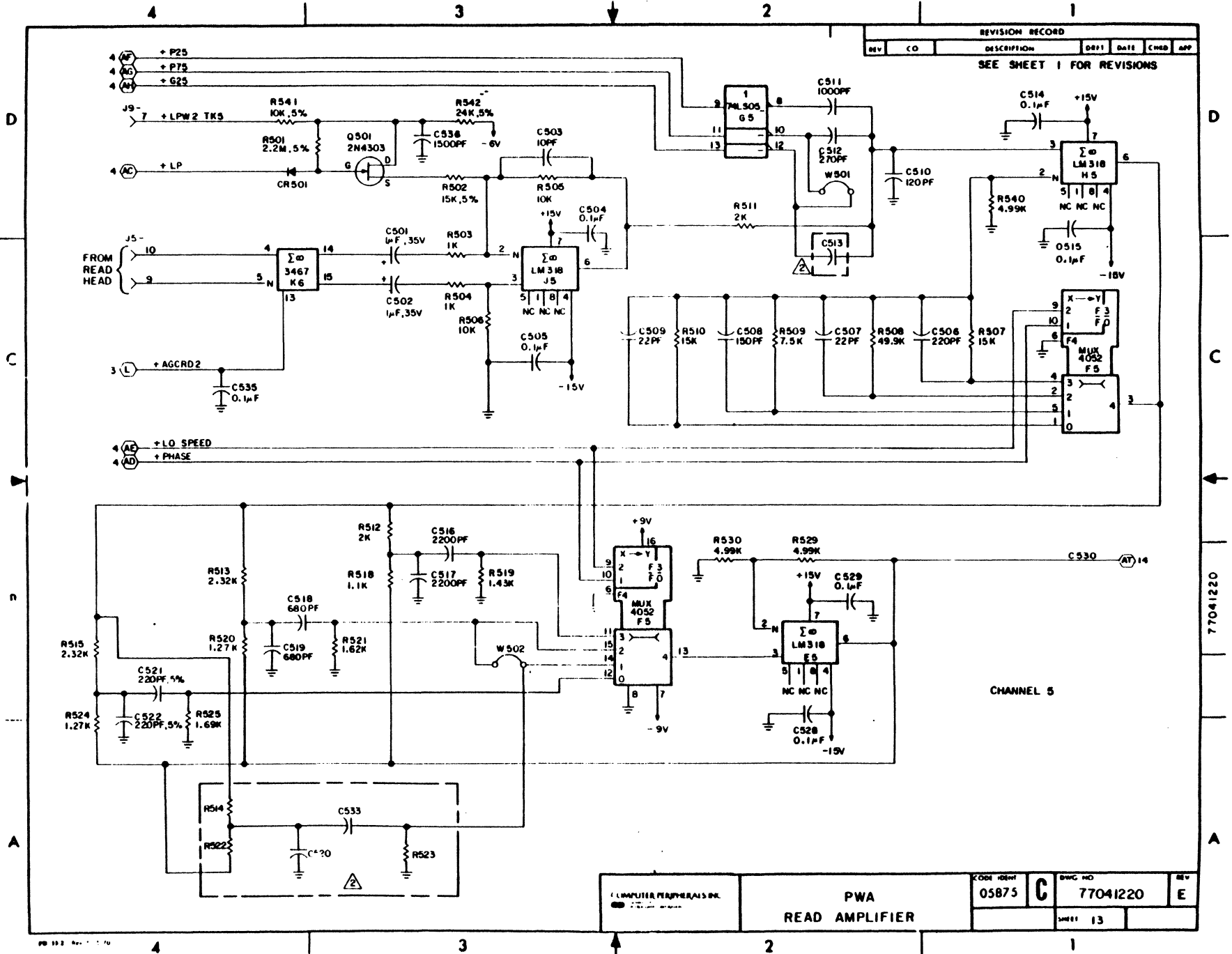

COMPUTER PERIPHERALS INC.	PWA	CODE IDENT	DWG NO	REV
	READ AMPLIFIER	05875	77041220	E
			DATE 13	

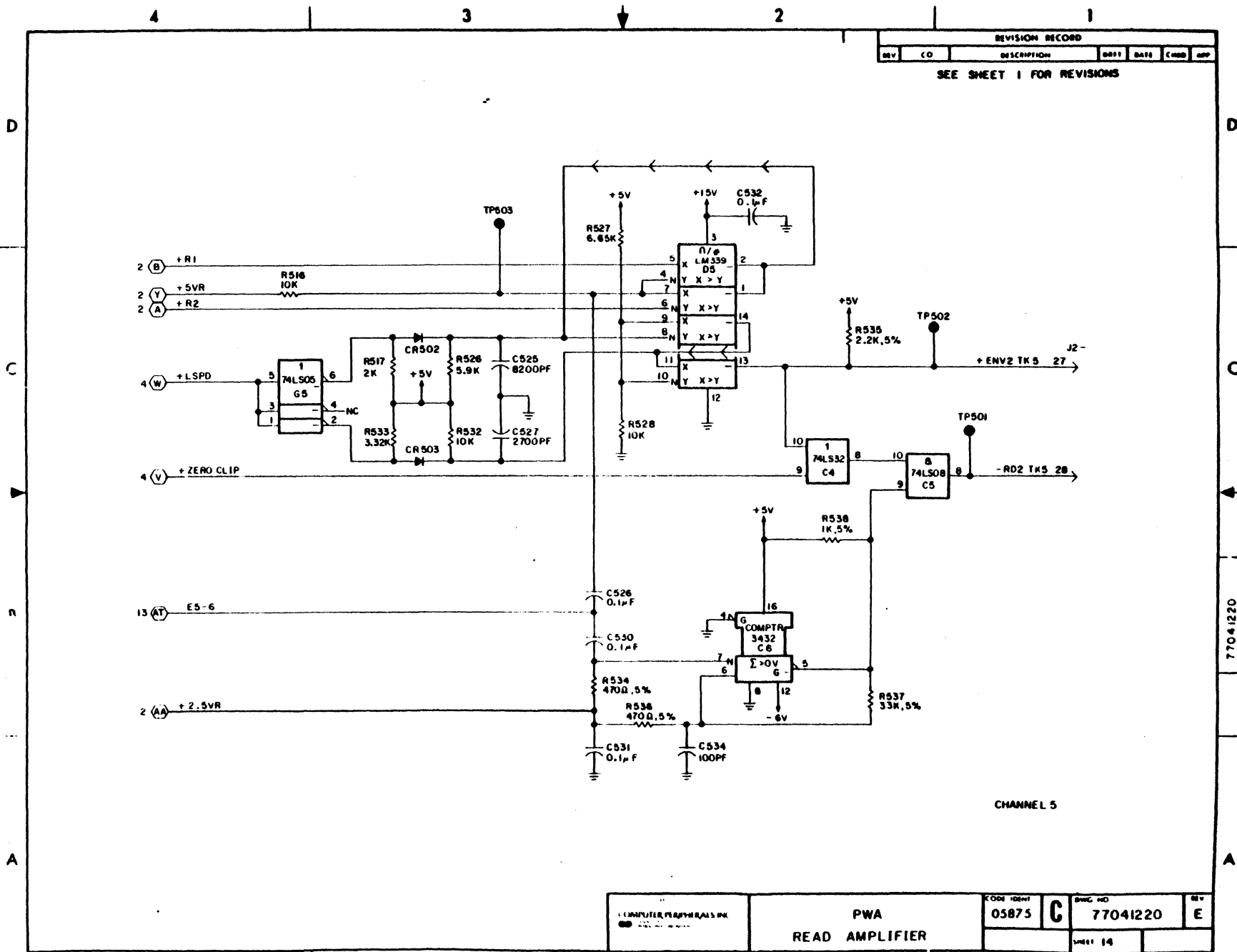

REVISION RECORD					
REV	CO	DESCRIPTION	DATE	CHKD	APP
SEE SHEET 1 FOR REVISIONS					

CHANNEL 5

COMPUTER PERIPHERALS INC. 1225 N. 17th St. Phoenix, Arizona 85016	PWA		CODE IDENT	DRWG NO	REV
	READ AMPLIFIER		05875	G 77041220	E
			SHEET 14		

49763000 B

S-57

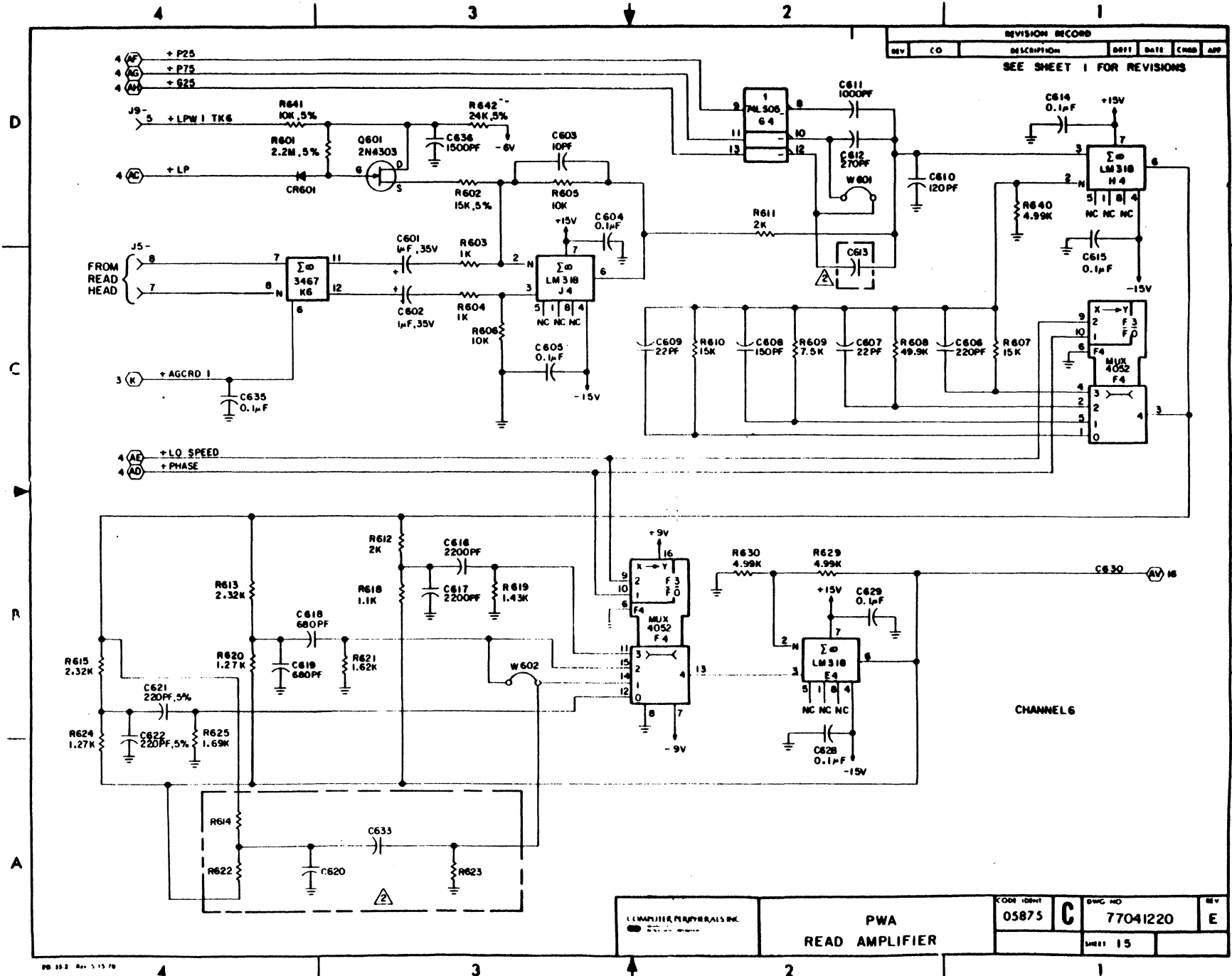

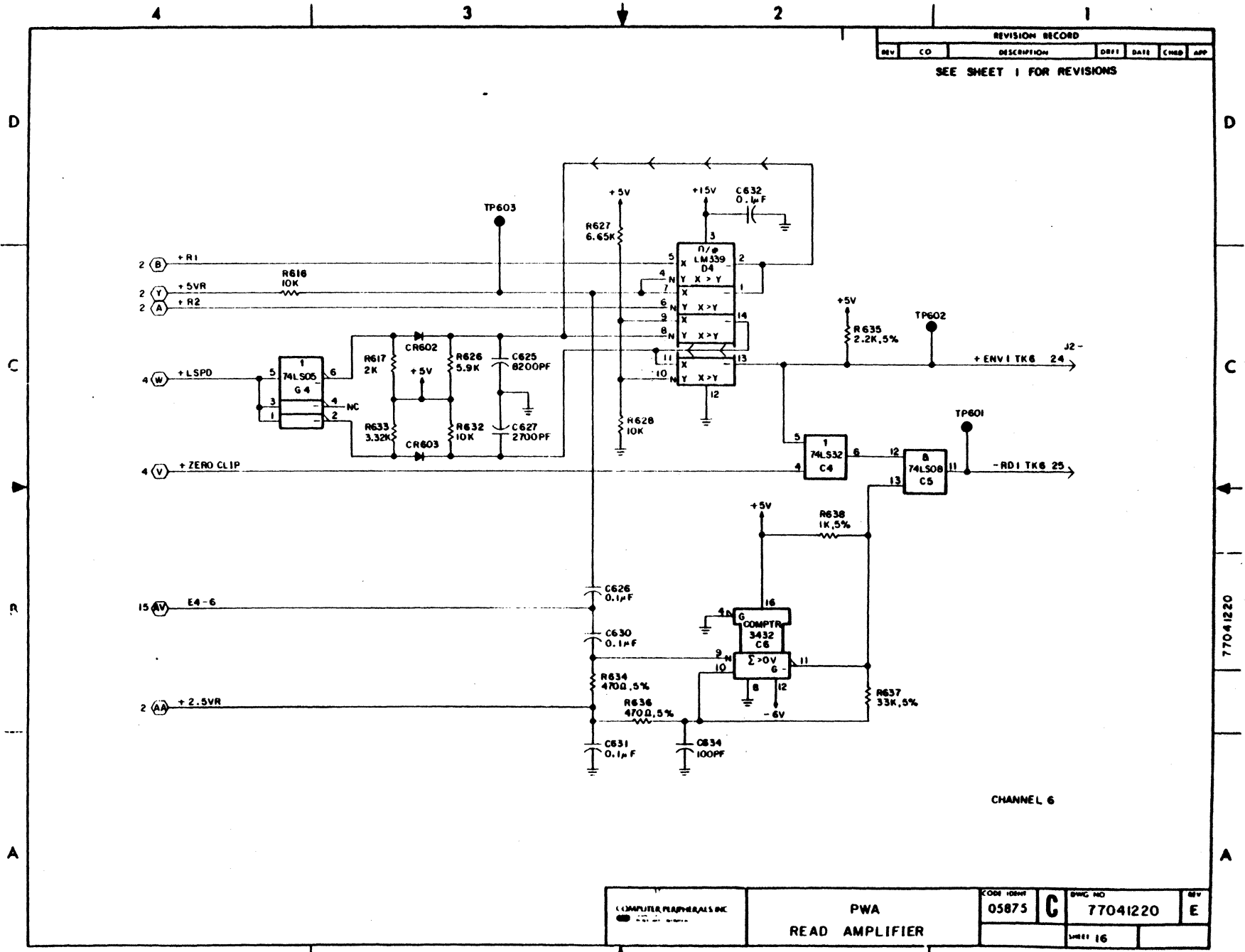

REVISION RECORD						
REV	CO	DESCRIPTION	DRFT	DATE	CHKD	APP
SEE SHEET 1 FOR REVISIONS						

CHANNEL 6

COMPUTER RESEARCHS INC 	PWA READ AMPLIFIER		CODE 10847 05875	DRWG NO G 77041220	REV E
				SHEET 16	

77041220

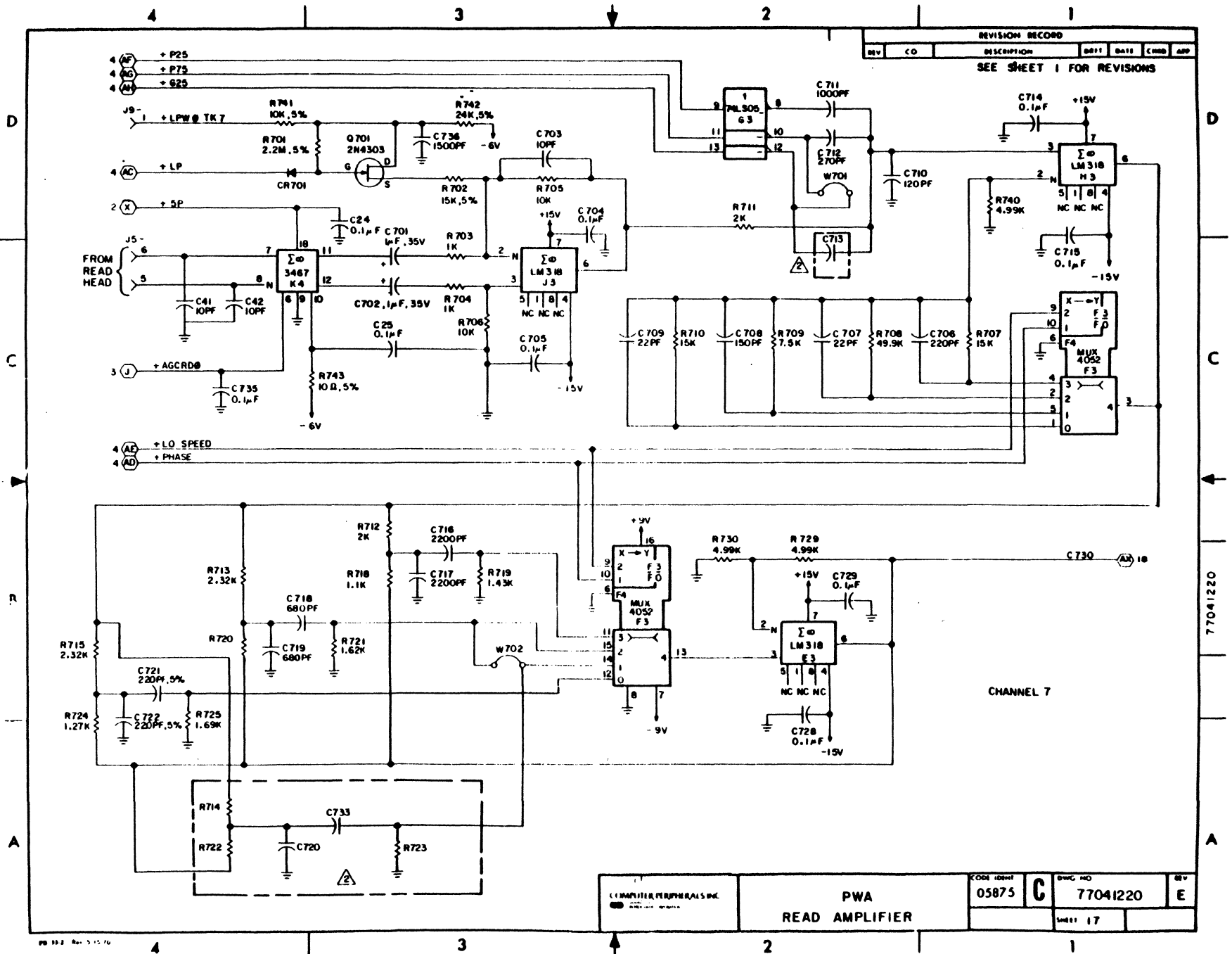

77041220

REVISION RECORD						
REV	CO	DESCRIPTION	DRFT	DATE	CHKD	APP
SEE SHEET 1 FOR REVISIONS						

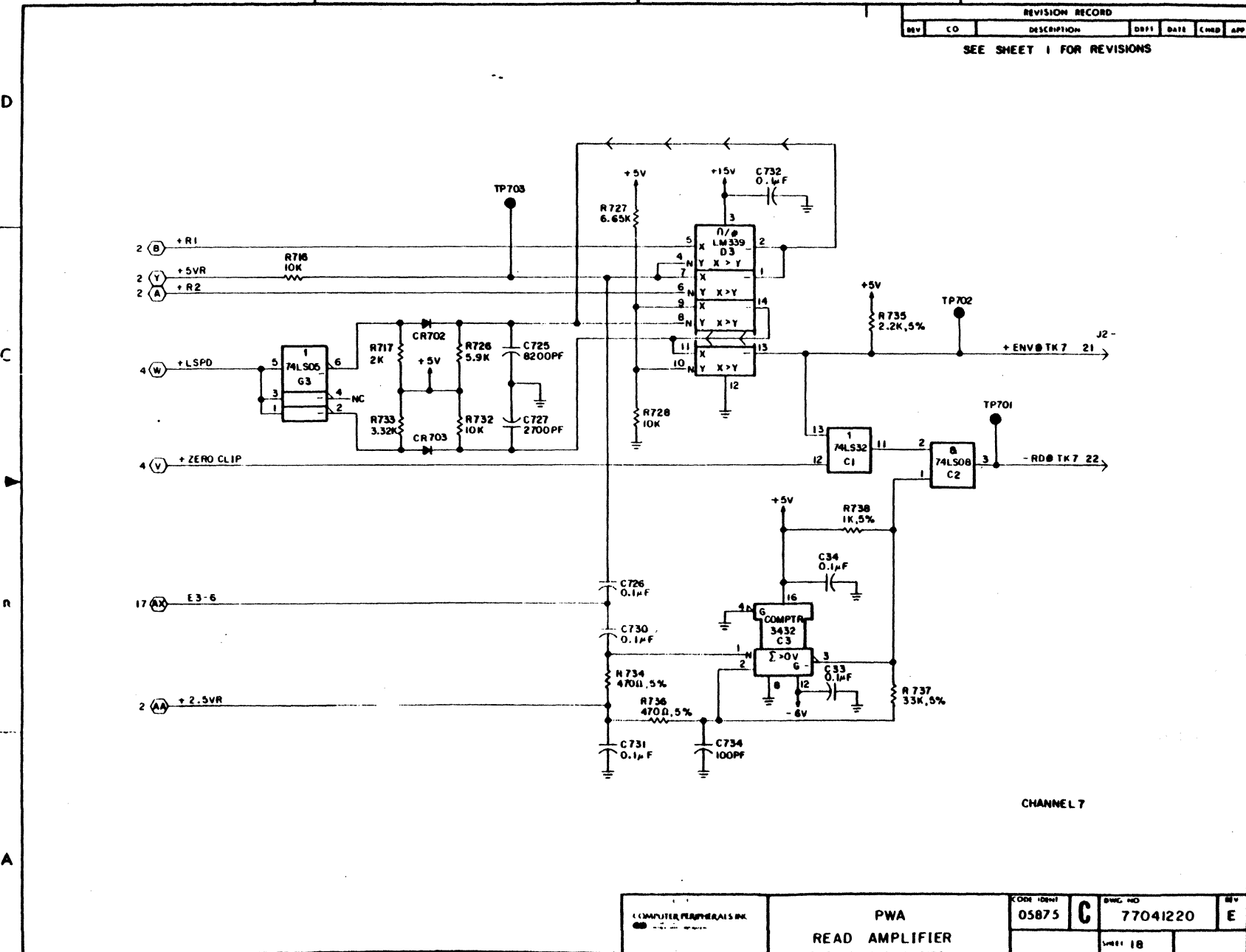

CHANNEL 7

COMPUTER PERIPHERALS INC.	PWA READ AMPLIFIER		CODE IDENT	C	SWG. NO.	REV
			05875		77041220	
			PAGE 18			

77041220



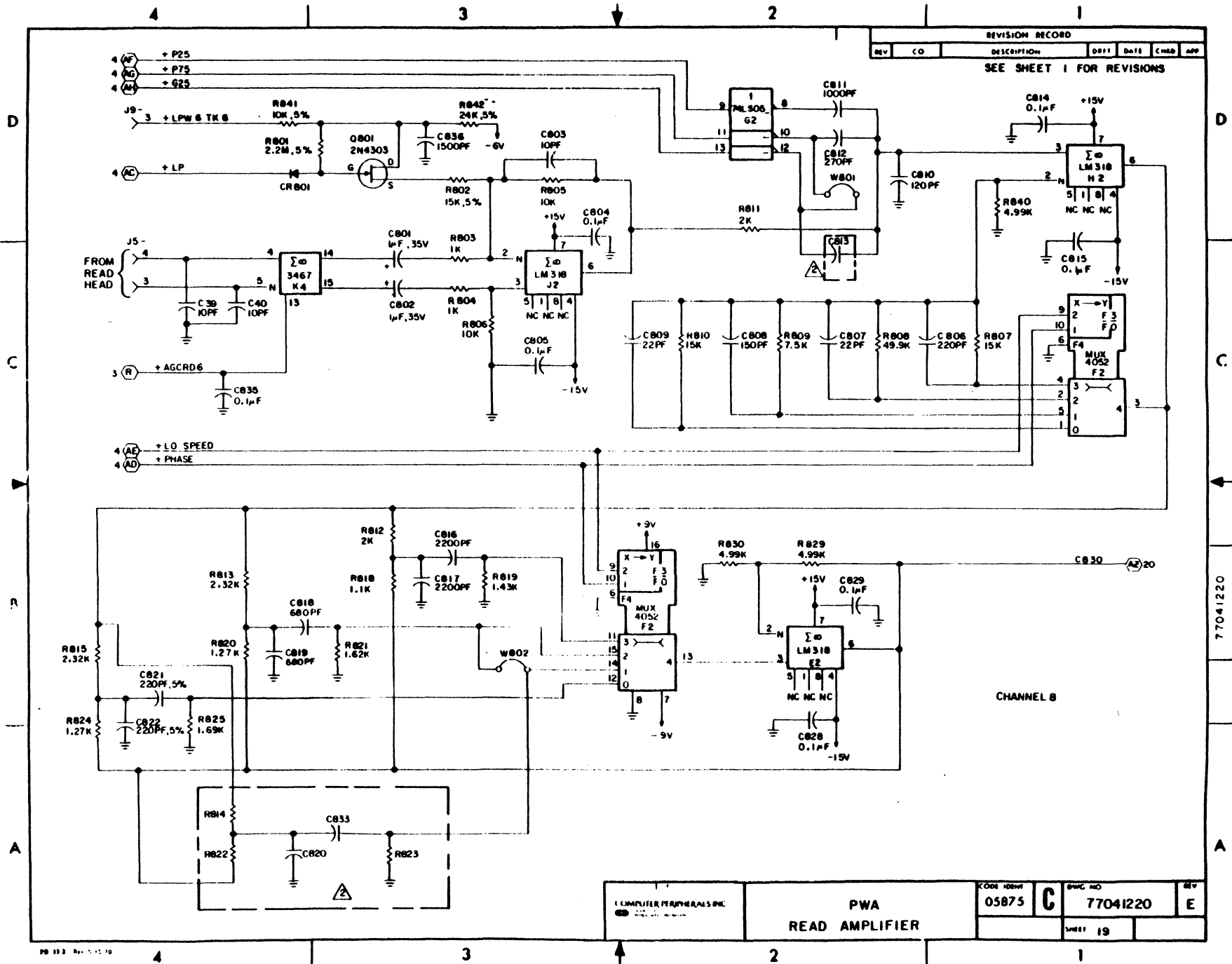

REVISION RECORD						
REV	CO	DESCRIPTION	DATE	CHKD	APP	
SEE SHEET 1 FOR REVISIONS						

CHANNEL B

COMPUTER PERIPHERALS INC.	PWA	CODE IDENT	Q	QWC NO	REV
	READ AMPLIFIER	05875		77041220	E
				SHEET 19	

77041220

REVISION RECORD						
REV	CO	DESCRIPTION	DRFT	DATE	CHKD	APP
SEE SHEET 1 FOR REVISIONS						

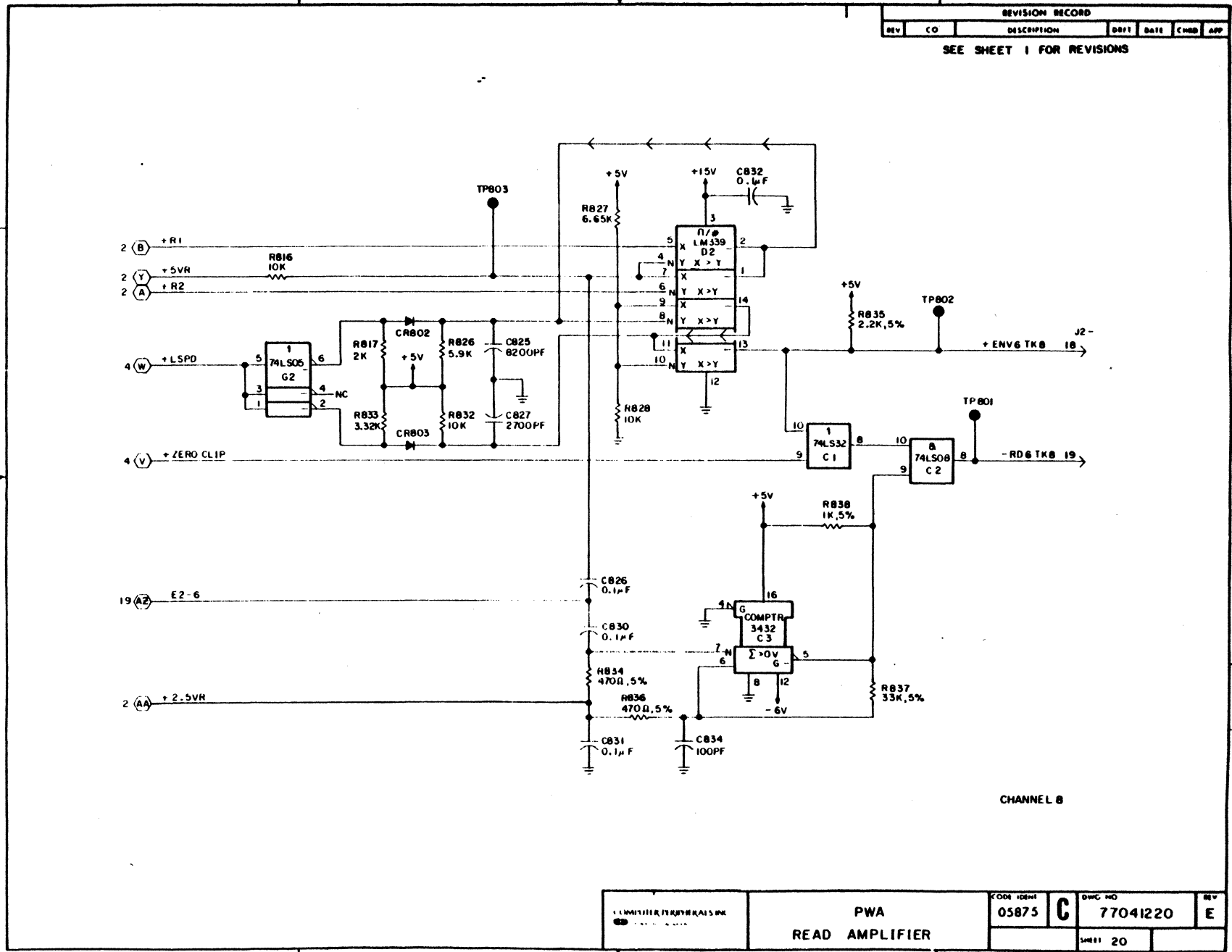

CHANNEL 8

COMPUTER PRODUCTS INC 10000 WILSON BLVD CHICAGO, ILL 60654	<b>PWA</b>		CODE IDENT	DWG NO	REV
	<b>READ AMPLIFIER</b>		05875	<b>C</b> 77041220	<b>E</b>
			SHEET 20		

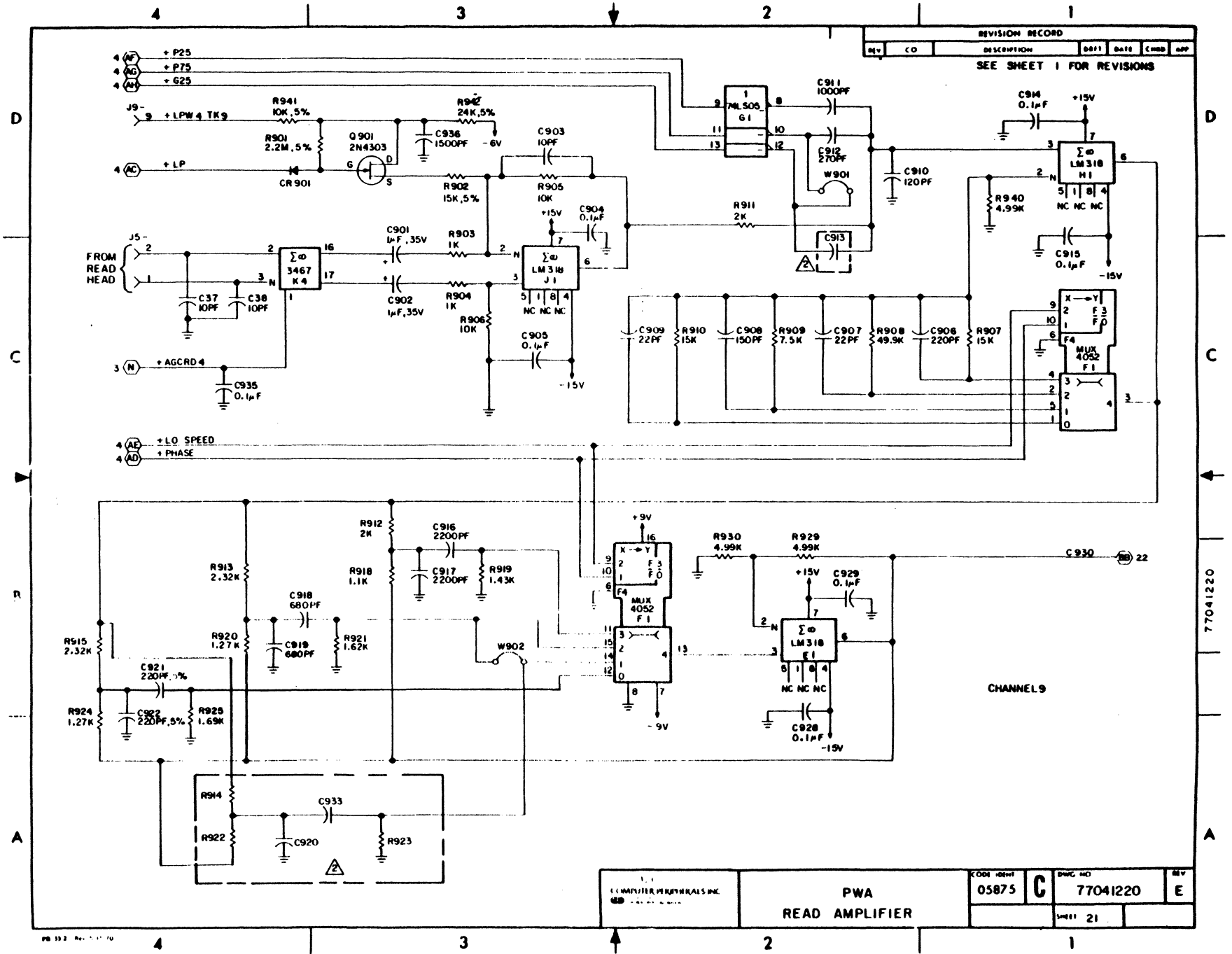

77041220

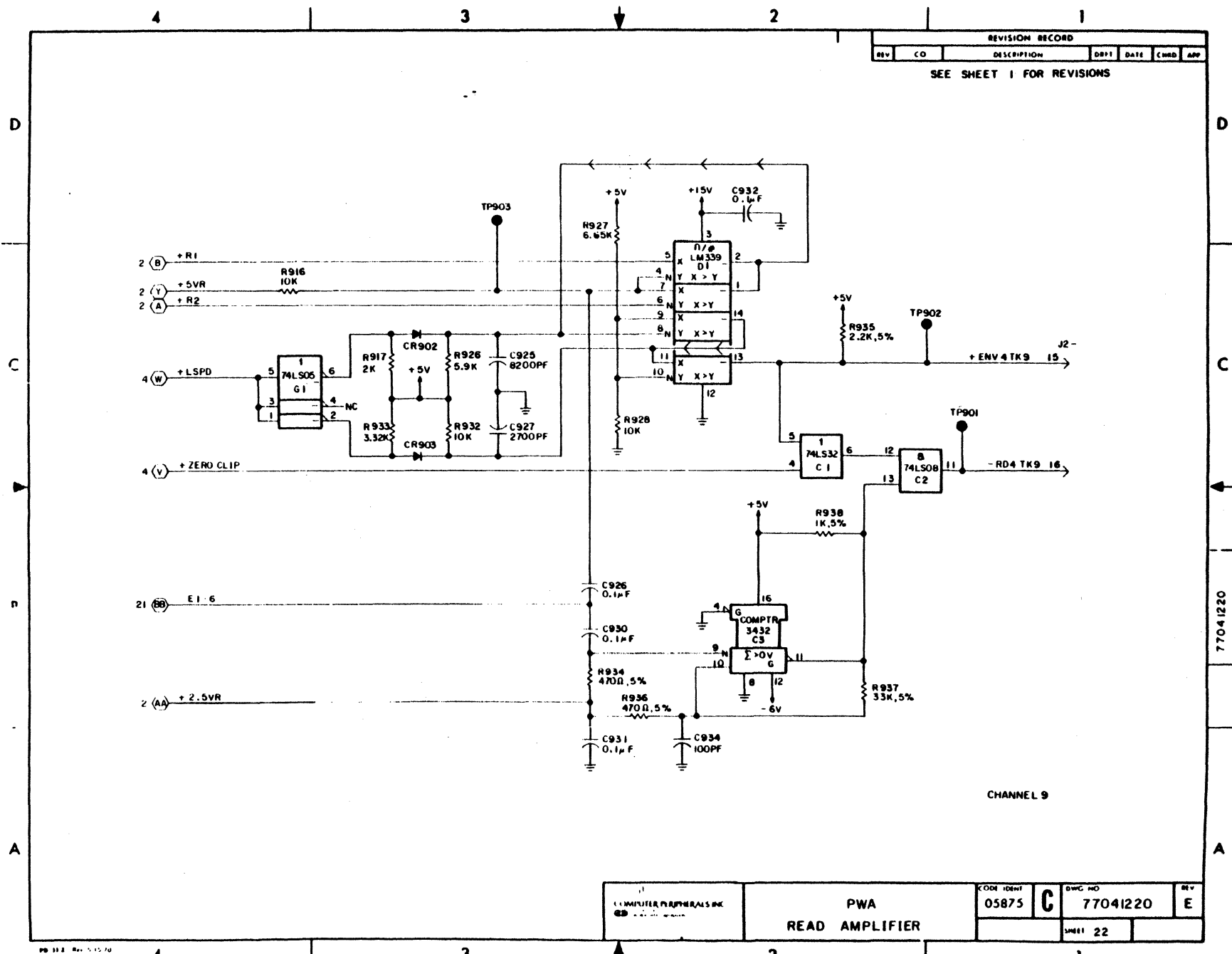

REVISION RECORD					
REV	CO	DESCRIPTION	DRY1	DATE	CHKD APP
SEE SHEET 1 FOR REVISIONS					

CHANNEL 9

COMPUTER PERIPHERALS INC 68	PWA READ AMPLIFIER		CODE IDENT	DWG NO	REV
			05875	C 77041220	E
			SHEET 22		

77041220

49763000

S-65

4 3 2 1

REVISION RECORD						
REV	CO	DESCRIPTION	DRFT	DATE	CHKD	APP

SEE SHEET 1 FOR REVISIONS

D

D

C

C

B

77041220

A

A

J3- 2	+WD5 TR1	J6- 2
3	+WD7 TR2	3
5	+WD3 TR3	5
6	+WDP TR4	6
8	+WD2 TR5	8
9	+WD1 TR6	9
11	+WD8 TR7	11
12	+WD6 TR8	12
14	+WD4 TR9	14
15	+FILE PHO	15
17	+REWIND	17
18	+SPARE	18
20	-WD STROBE	20
21	-WRITE	21
22	-ERASE	22
23	-WR. BY DEG	23
25	-CTR. WIN	25
26	-ER. CUN	26
27	-WR. CUN	27

COMPUTER PERIPHERALS INC. <small>1000 W. 10th St. - Denver, Colorado</small>	PWA READ AMPLIFIER		CODE IDENT 05875	C	DWG NO 77041220	REV A
			SHEET 23			

4 3 2 1

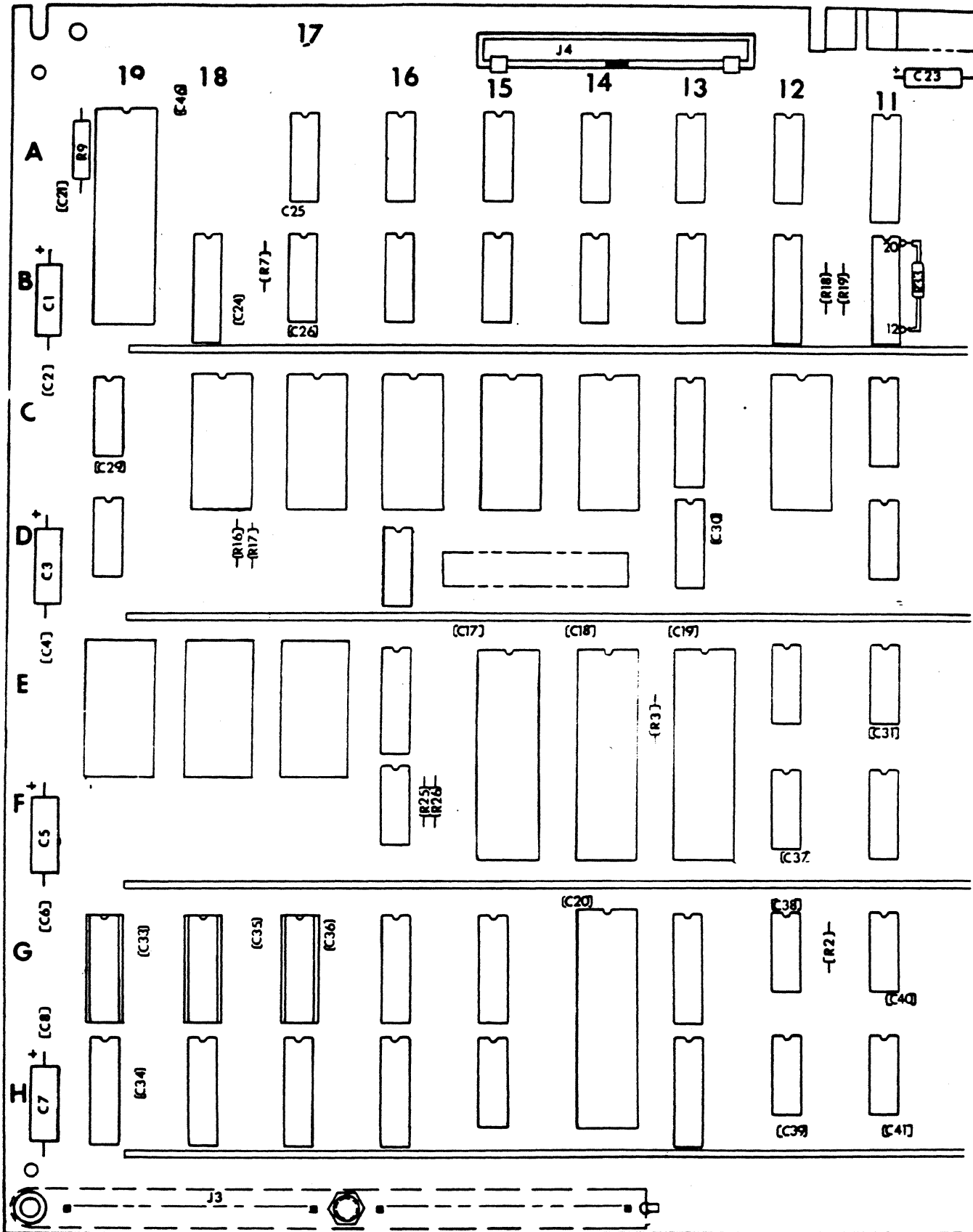

FORMATTER WRITE PWA 77025960

SHEET 1A

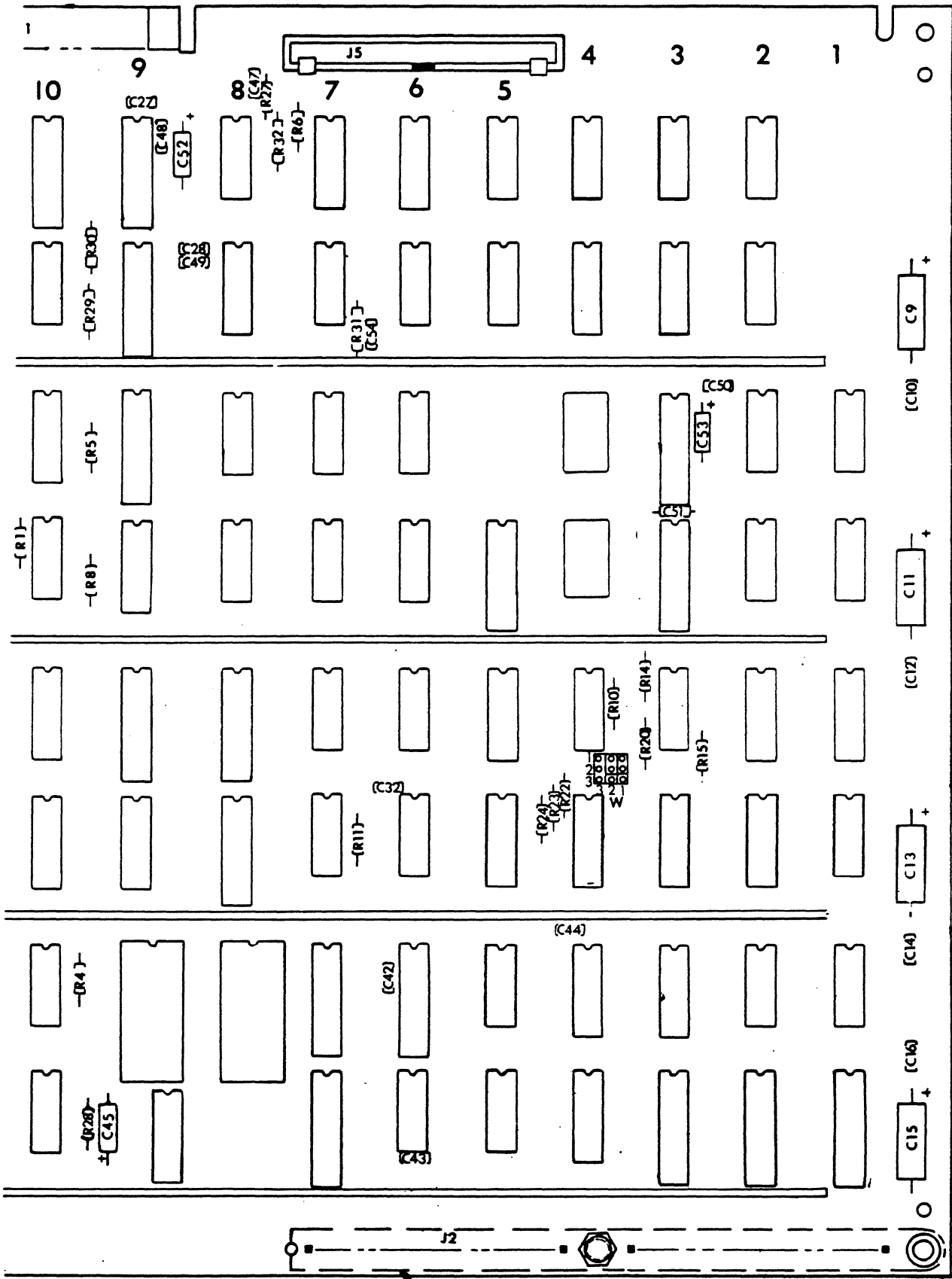

FORMATTER WRITE PWA 77025960

SHEET 1B

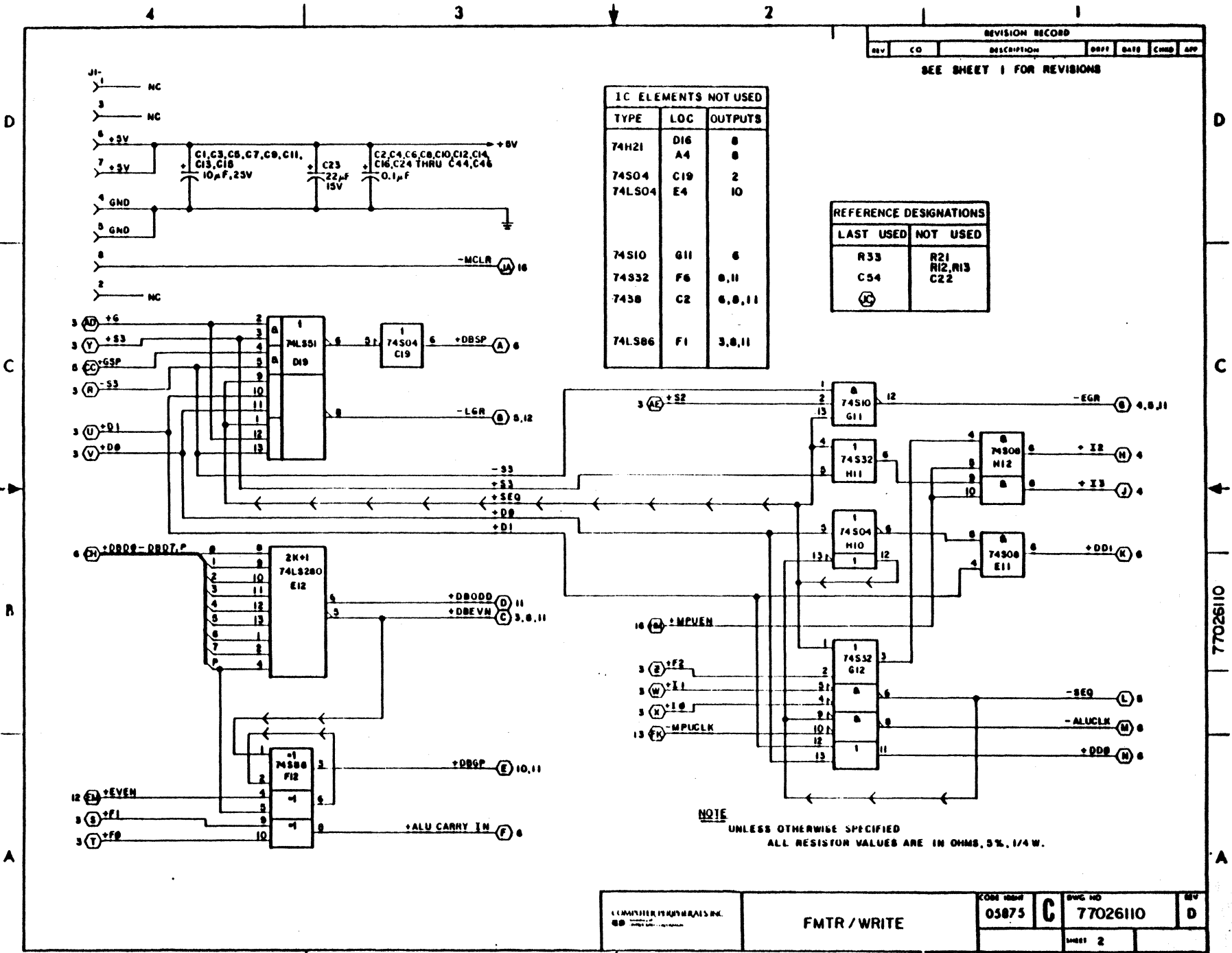

IC ELEMENTS NOT USED		
TYPE	LOC	OUTPUTS
74H21	D16	8
	A4	8
74S04	C19	2
74LS04	E4	10
74S10	G11	6
74S32	F6	8, 11
7438	C2	6, 8, 11
74LS86	F1	3, 8, 11

REFERENCE DESIGNATIONS	
LAST USED	NOT USED
R33	R21, R12, R13
C54	C22

REVISION RECORD						
REV	CO	DESCRIPTION	BY	DATE	CHKD	APP
SEE SHEET 1 FOR REVISIONS						

NOTE  
UNLESS OTHERWISE SPECIFIED  
ALL RESISTOR VALUES ARE IN OHMS, 5%, 1/4 W.

COMPUTER PRODUCTS INC.	FMT R / WRITE	CODE 05875	DWG NO 77026110	REV D
			SHEET 2	

77026110



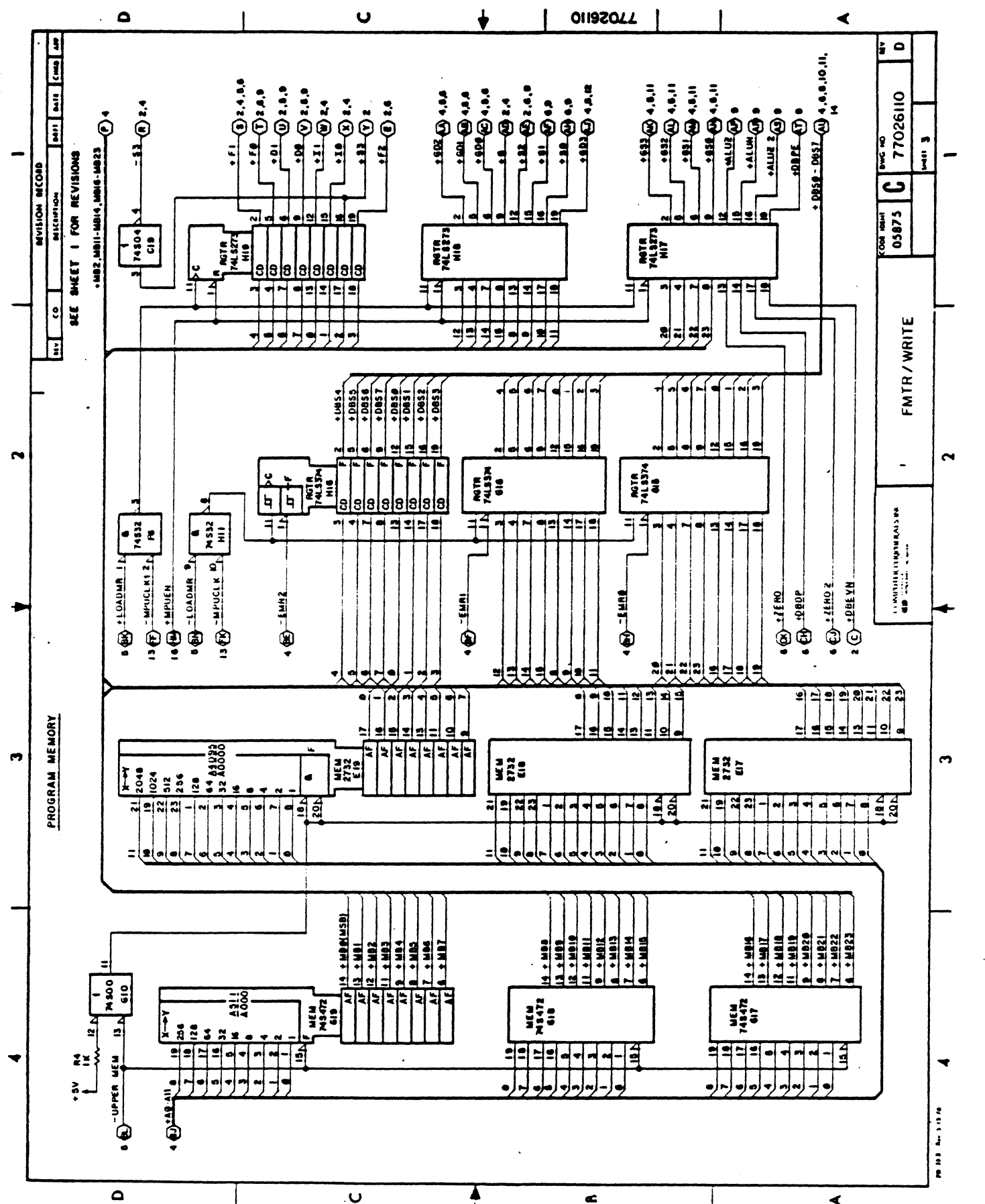

REVISION RECORD

REV	CD	DESCRIPTION	DATE	BY	CHKD	APP
1		SEE SHEET 1 FOR REVISIONS				

• M02-M011-M014, M016-M023

PROGRAM MEMORY

X→Y	MEM	ADDRESS
21	2732	E19
19	2732	E19
18	2732	E19
17	2732	E19
16	2732	E19
15	2732	E19
14	2732	E19
13	2732	E19
12	2732	E19
11	2732	E19
10	2732	E19
9	2732	E19
8	2732	E19
7	2732	E19
6	2732	E19
5	2732	E19
4	2732	E19
3	2732	E19
2	2732	E19
1	2732	E19
0	2732	E19

FMTR / WRITE

CODE MEMORY

05875
-------

D 77026110

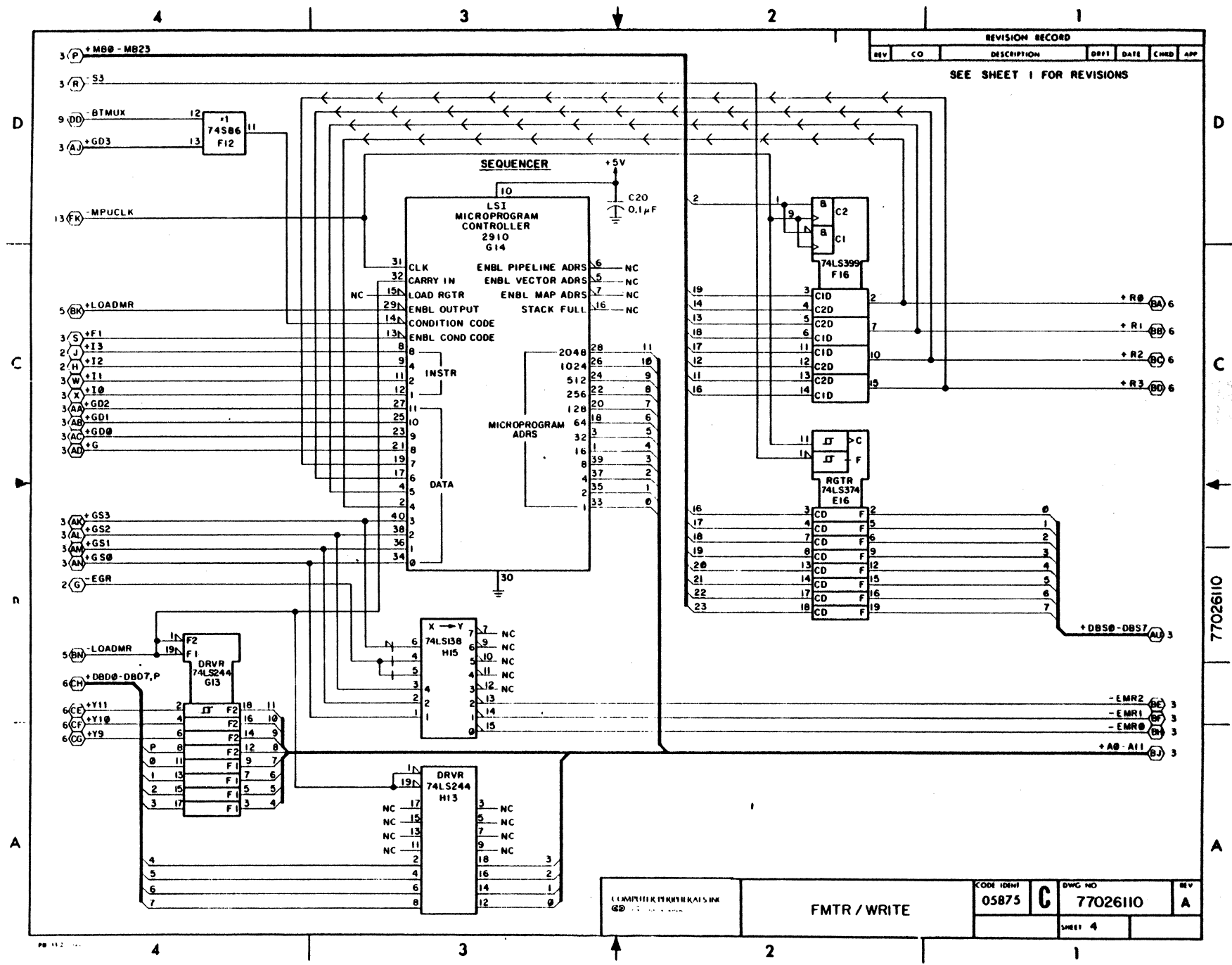

REVISION RECORD						
REV	CO	DESCRIPTION	DR11	DATE	CMND	APP
SEE SHEET 1 FOR REVISIONS						

COMPUTER PERIPHERALS INC 4801 ...	FMTR / WRITE	CODE IDENT	DWG NO	REV
		05875	C 77026110	A
		SHEET 4		

77026110

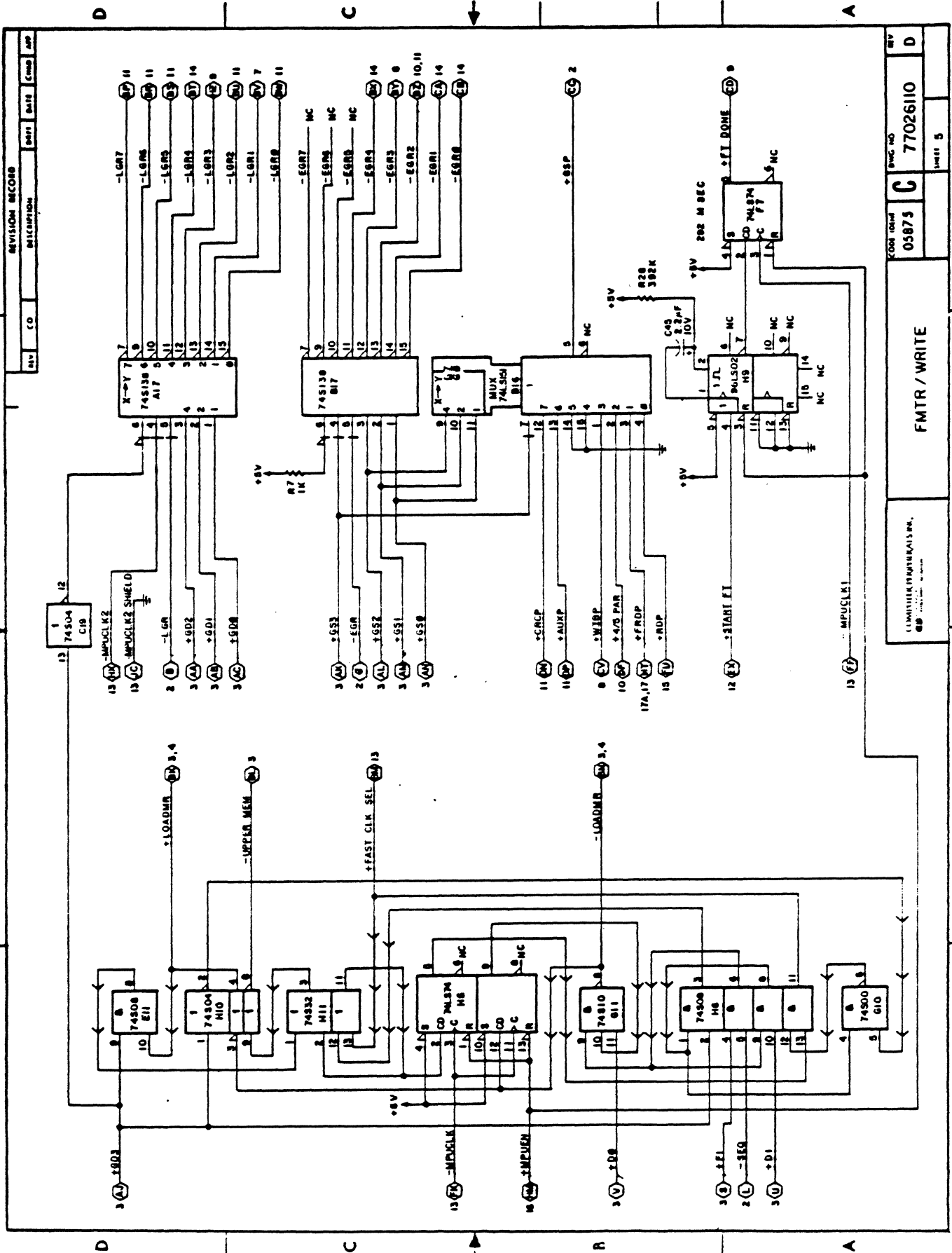

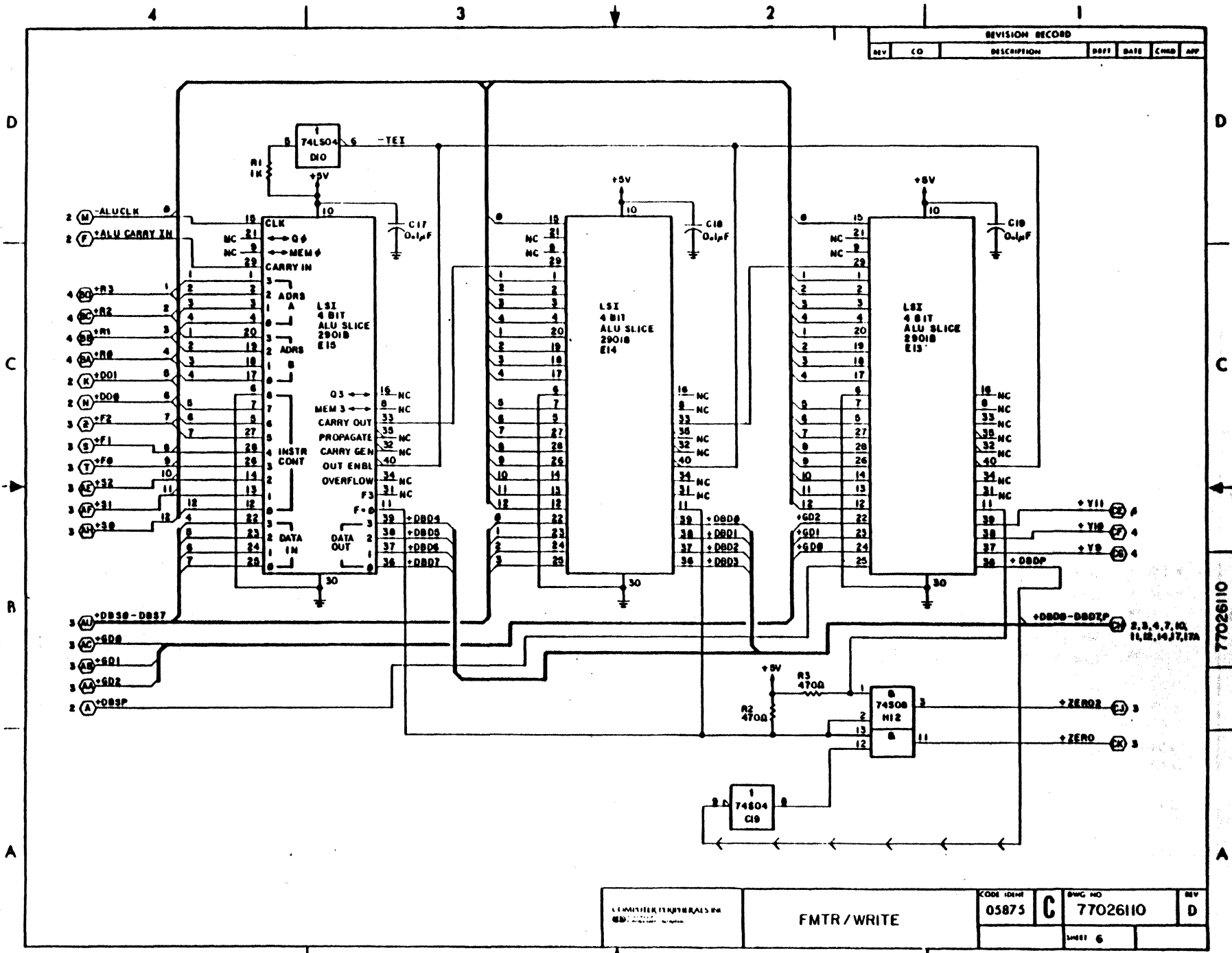

COMPUTER PERIPHERALS INC 6010 WILSON BLVD FORT WORTH, TEXAS 76102	FMTR / WRITE	CODE ID# 05875	DWG NO <b>C</b> 77026110	REV D
		SHEET 6		

77026110

49763000 K

S-73

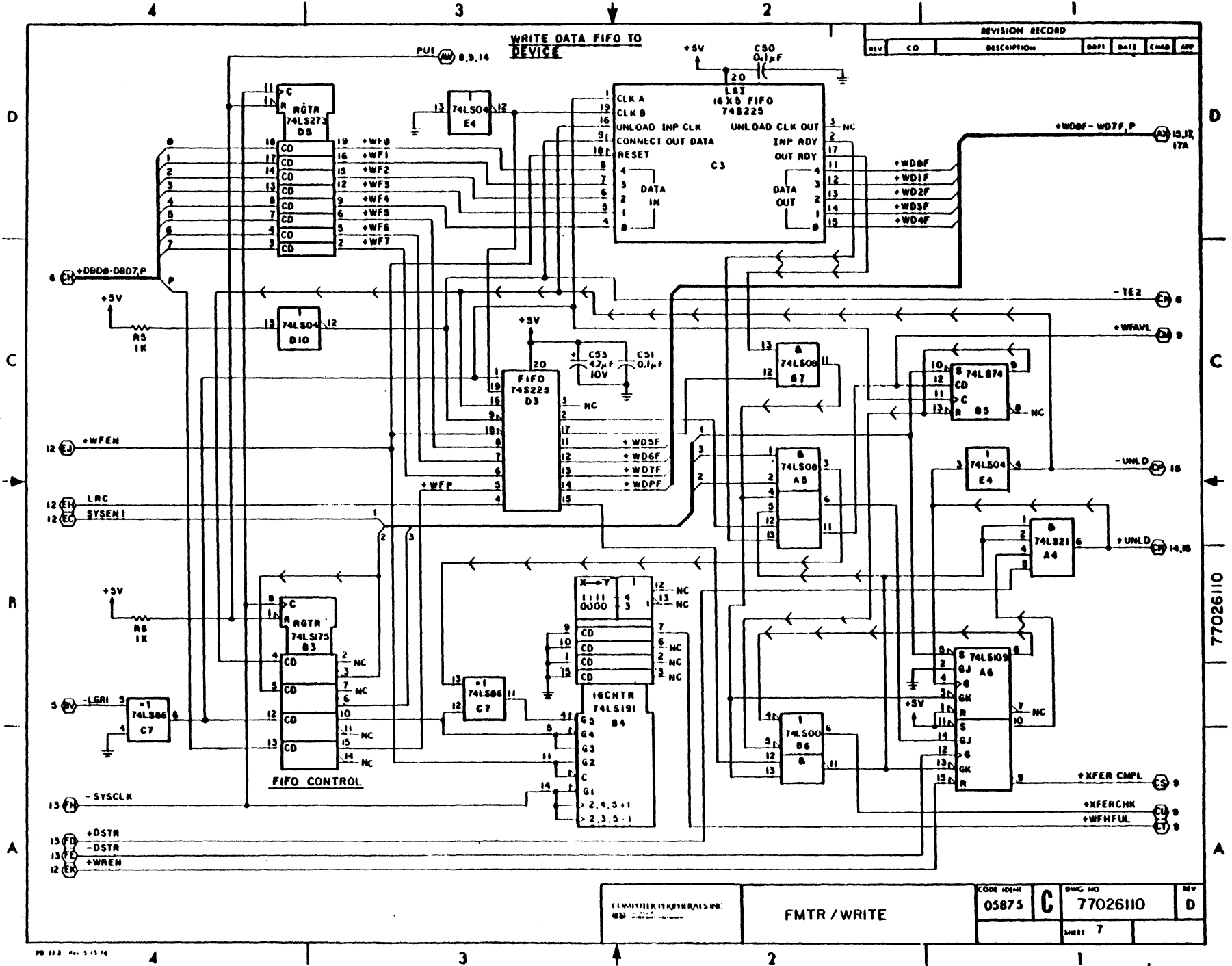

FMTR / WRITE

CODE IDENT	05875	DWG NO	C	77026110	REV	D
SHEET 7						

PH 223 Rev. 1-13-76

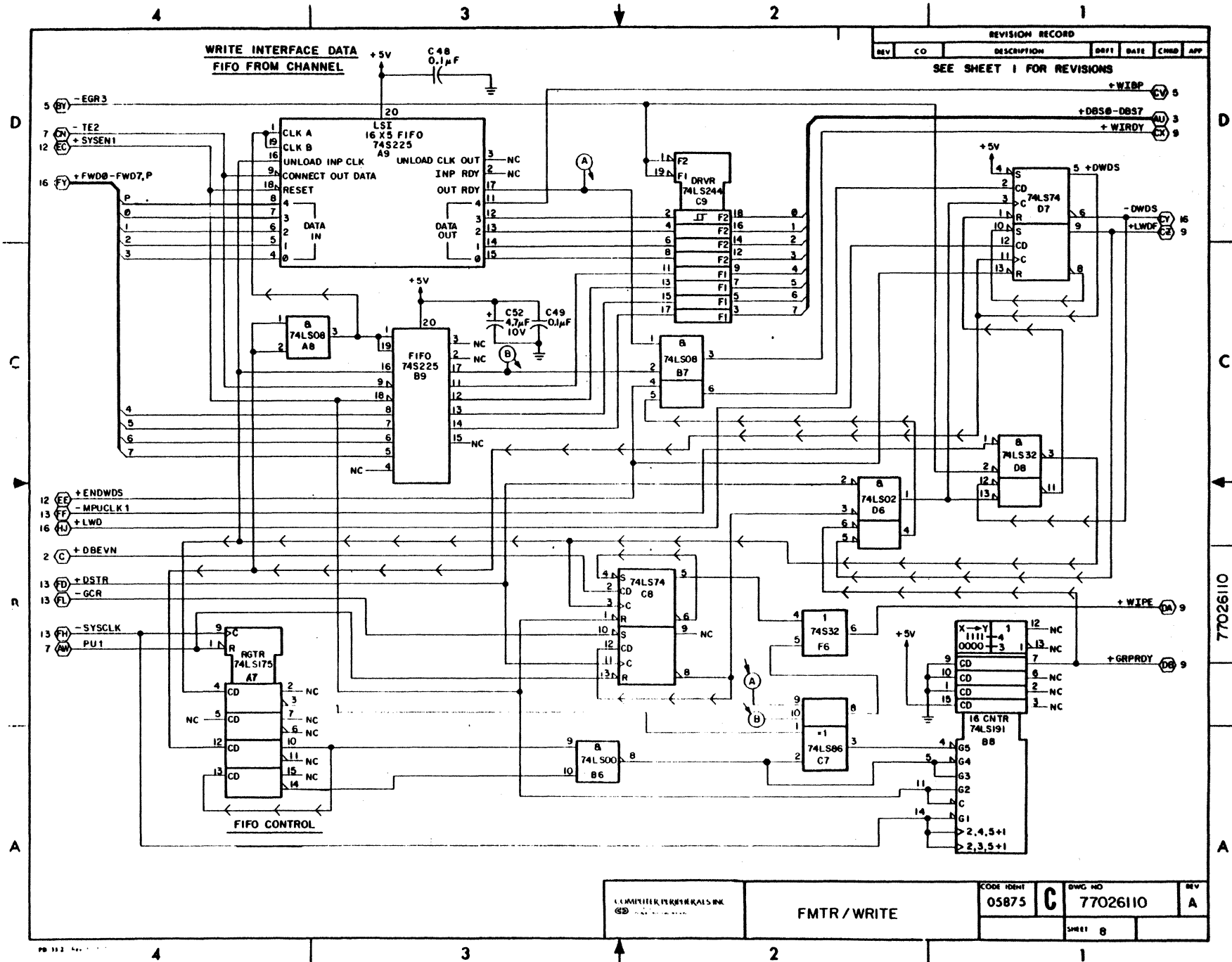

REVISION RECORD					
REV	CD	DESCRIPTION	DRFI	DATE	CHKD APP
SEE SHEET 1 FOR REVISIONS					

COMPUTER PERIPHERALS INC 9200	FMTR / WRITE		CODE IDENT 05875	C	DWG NO 77026110	REV A
					SHEET 8	

77026110

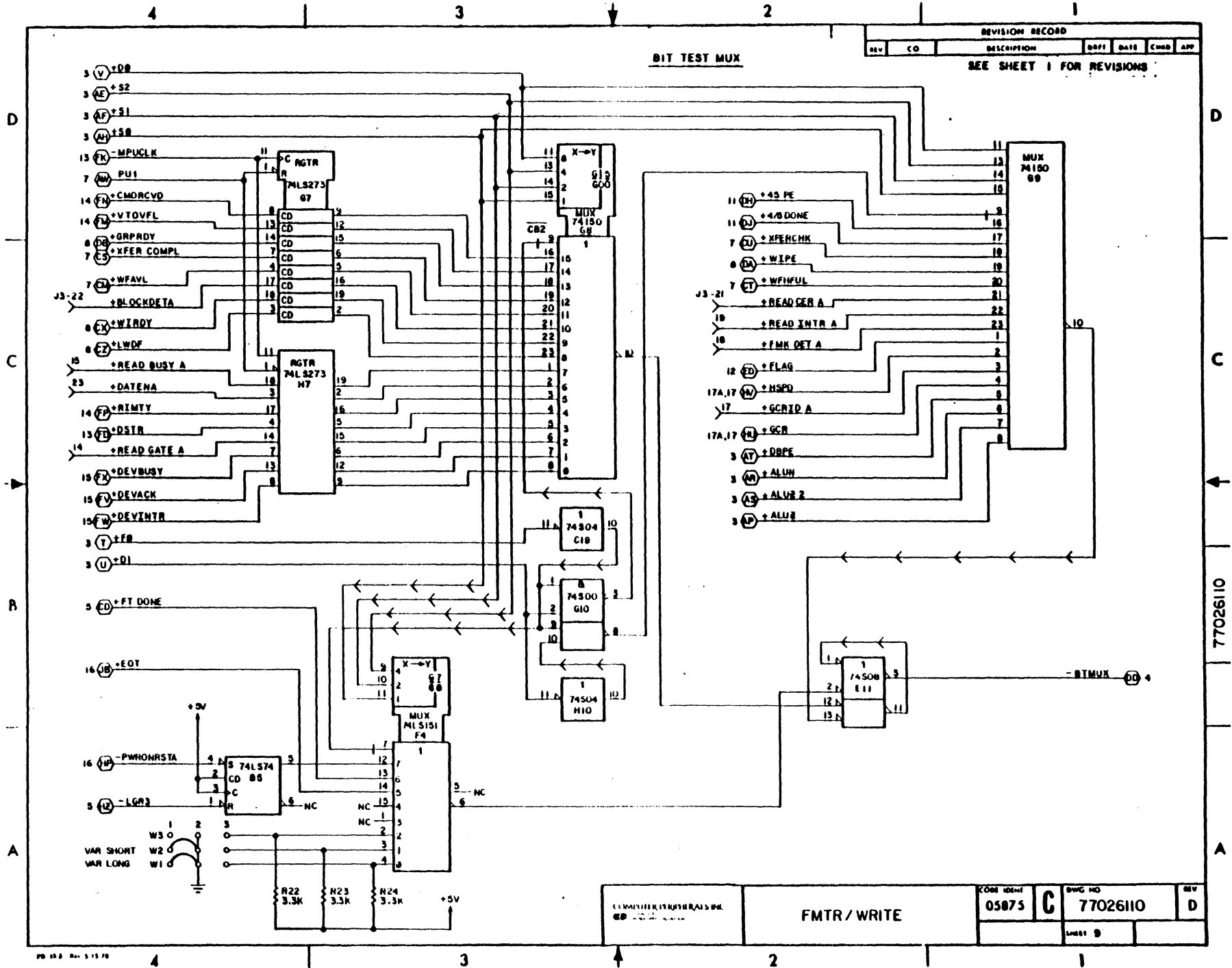

REVISION RECORD						
REV	CO	DESCRIPTION	DRFT	DATE	CHNG	APP
SEE SHEET 1 FOR REVISIONS						

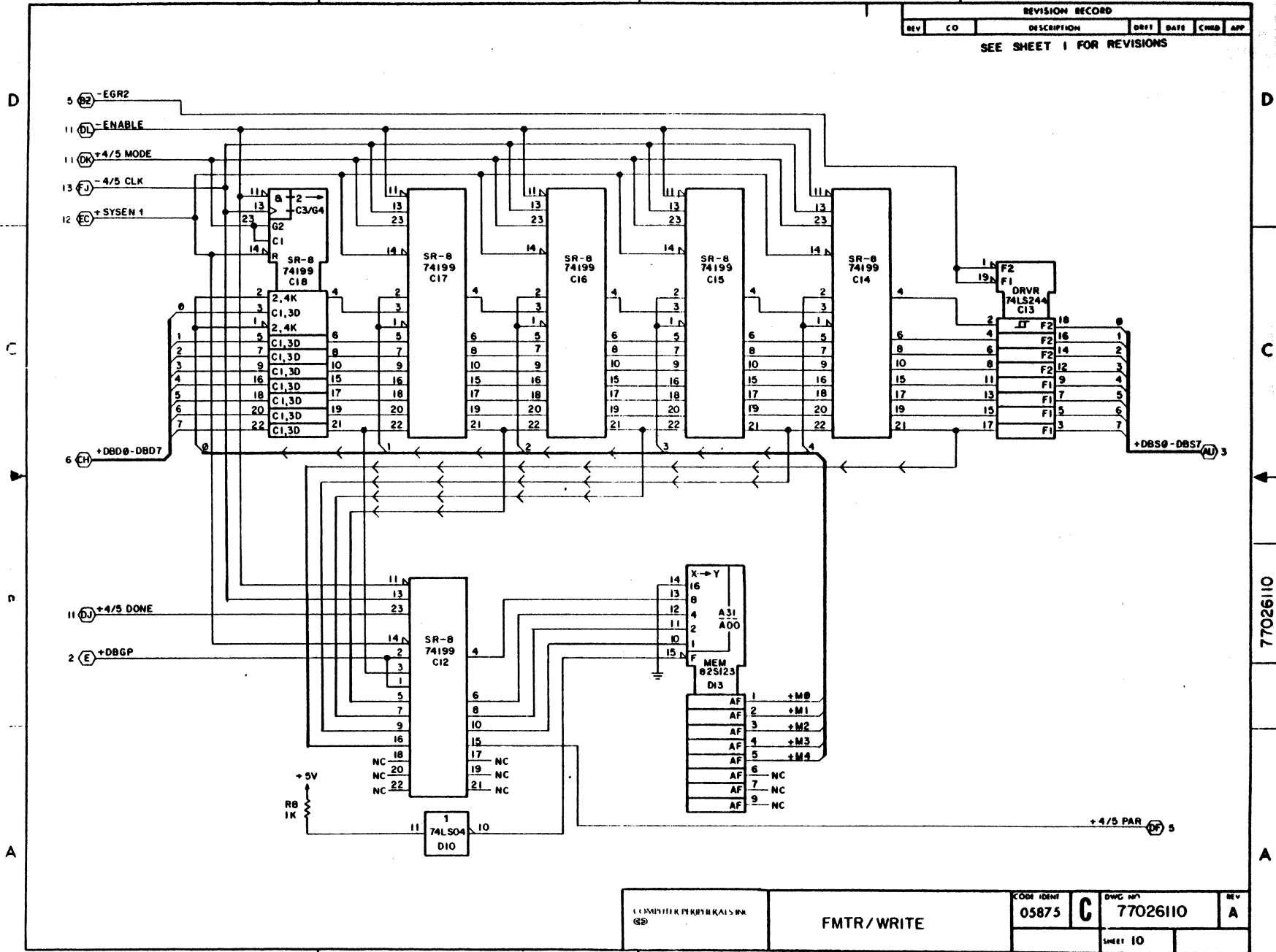

77026110

COMPUTER PERIPHERALS INC. ②	FMTR/WRITE	CODE IDENT	DWG NO	REV
		05875	C 77026110	A
		SHEET 10		



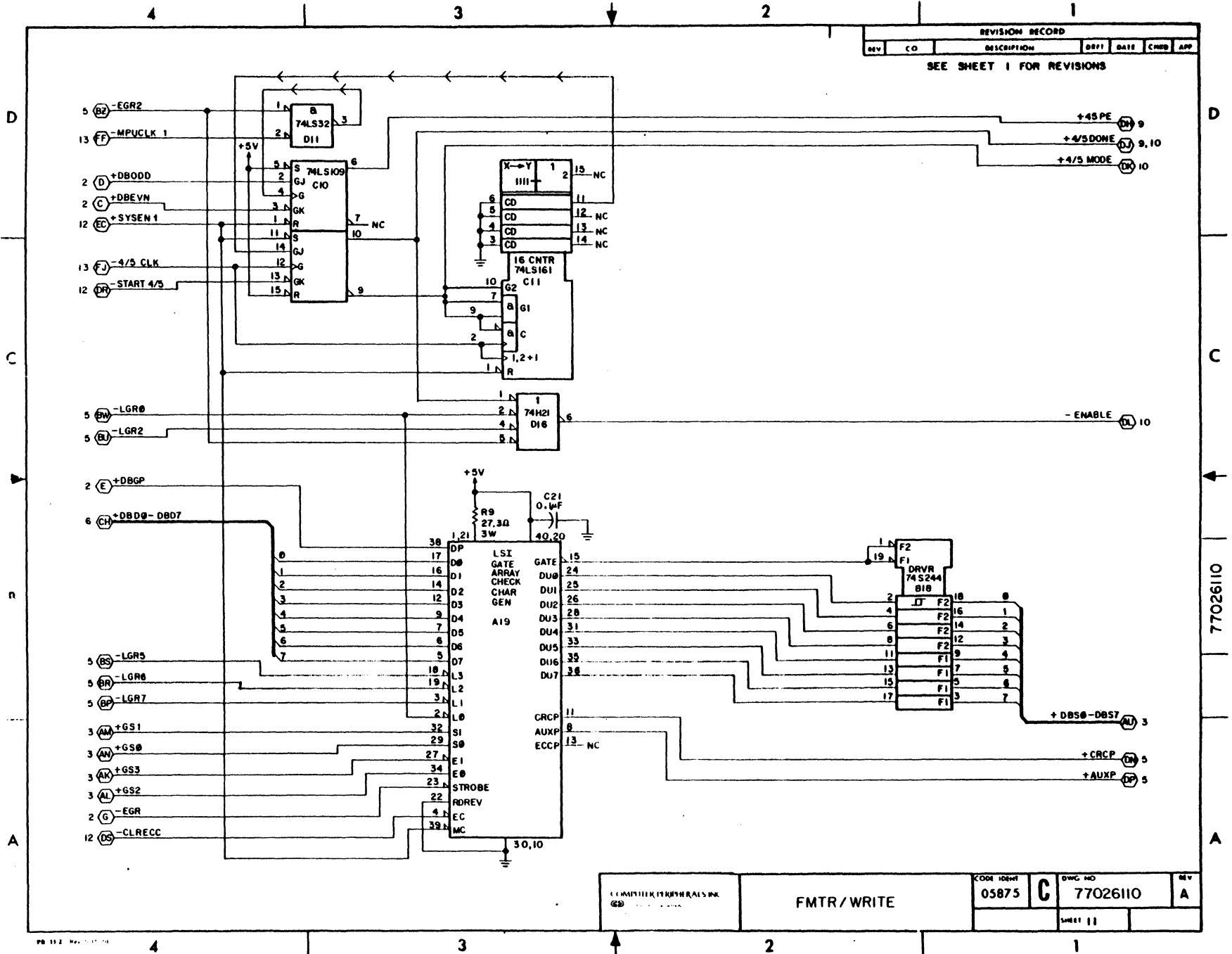

REVISION RECORD						
REV	CO	DESCRIPTION	DRFT	DATE	CHKD	APP
SEE SHEET 1 FOR REVISIONS						

COMPUTER PERIPHERALS INC.	FMTR/WRITE	CODE IDENT 05875	DWG NO 77026110	REV A
		SHEET 11		

77026110

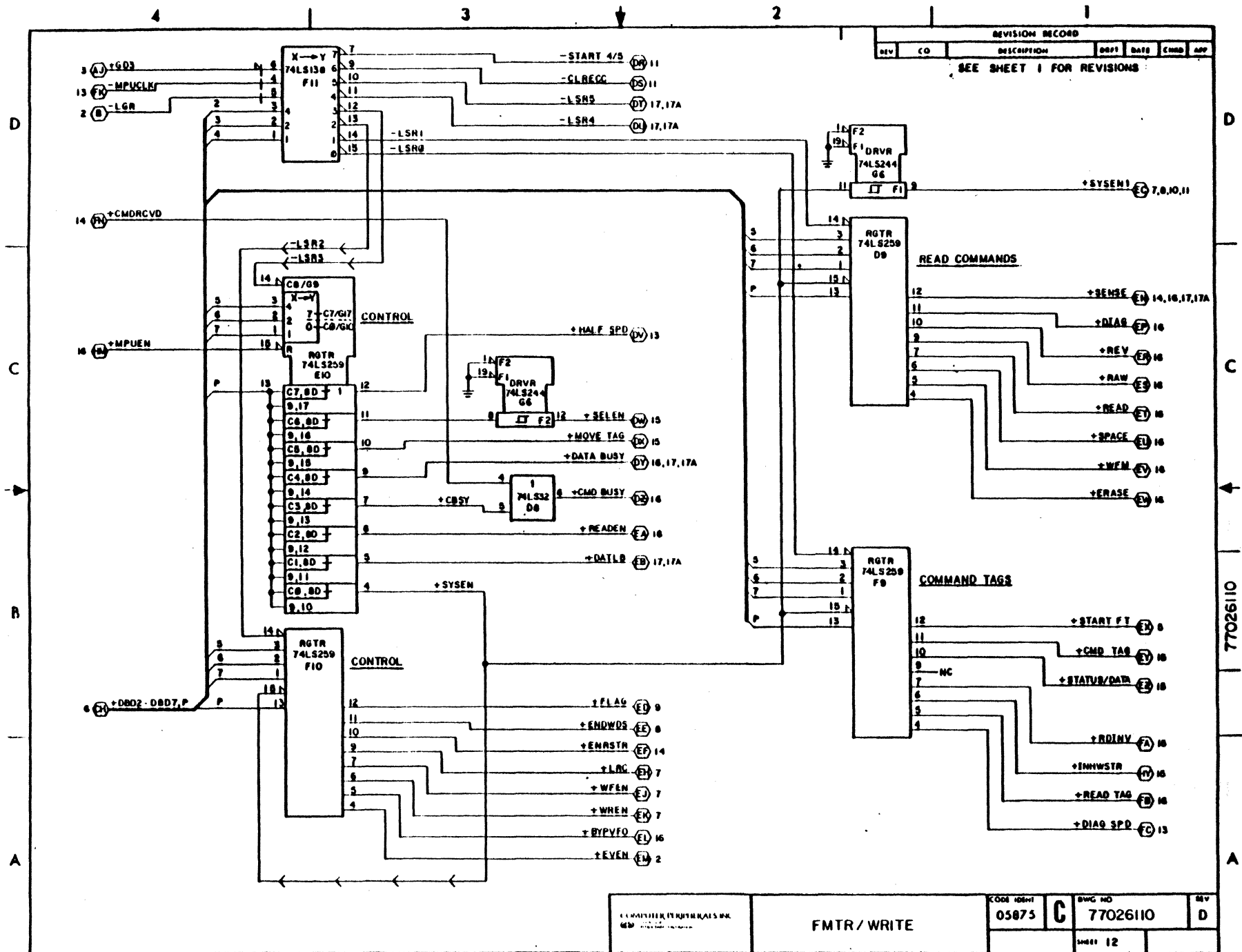

1. MANUFACTURER'S PART NO. 6B	<b>FMTR / WRITE</b>	CODE IDENT <b>05875</b>	DWG NO <b>C 77026110</b>	REV <b>D</b>
		SHEET 12		

77026110

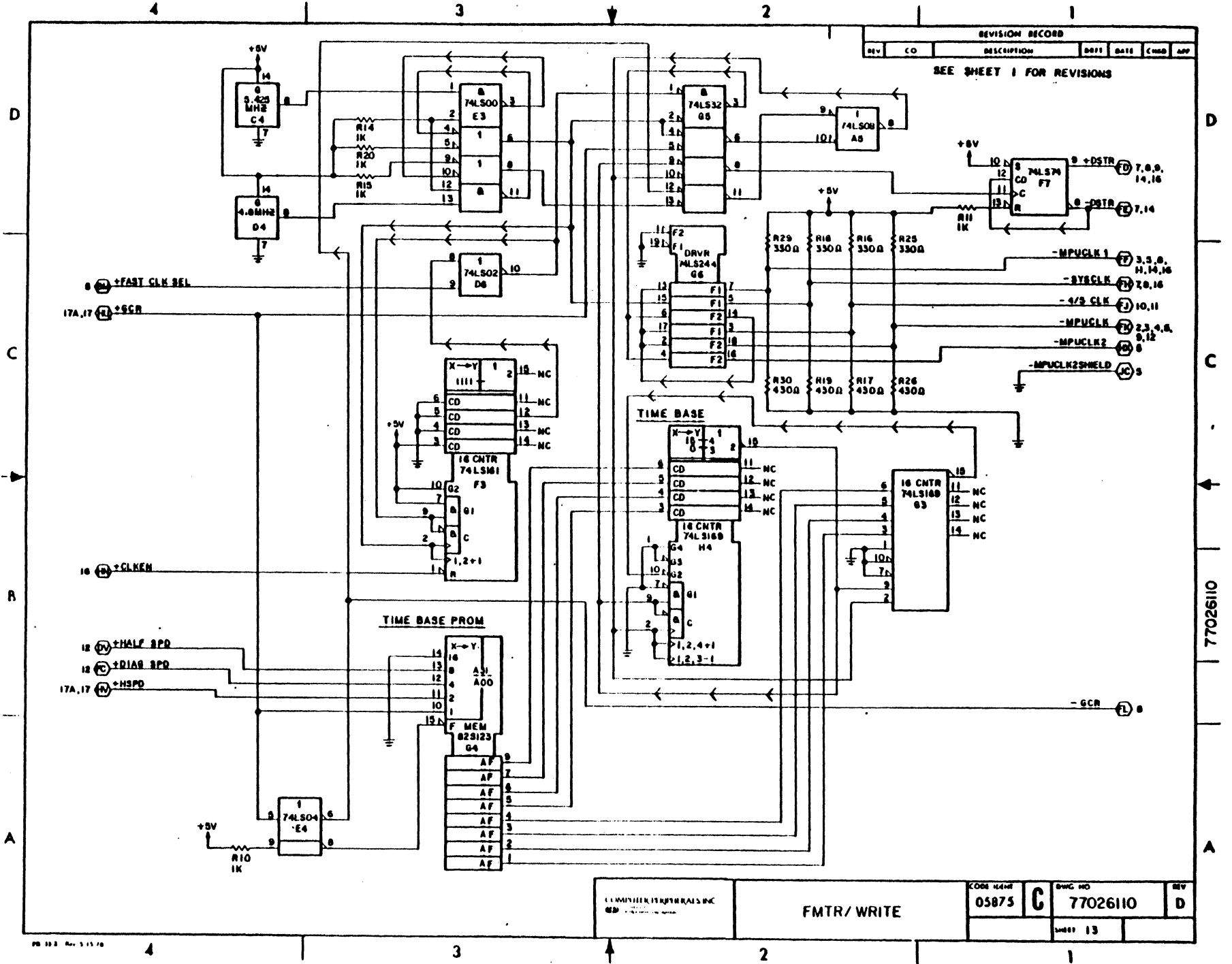

REVISION RECORD						
REV	CO	DESCRIPTION	DIFF	DATE	CMO	APP
SEE SHEET 1 FOR REVISIONS						

CODE 44#	QWC NO	REV
05875	C 77026110	D
SHEET 13		

ELMITEK SYSTEMS INC  
 601 ...

FMTR/ WRITE

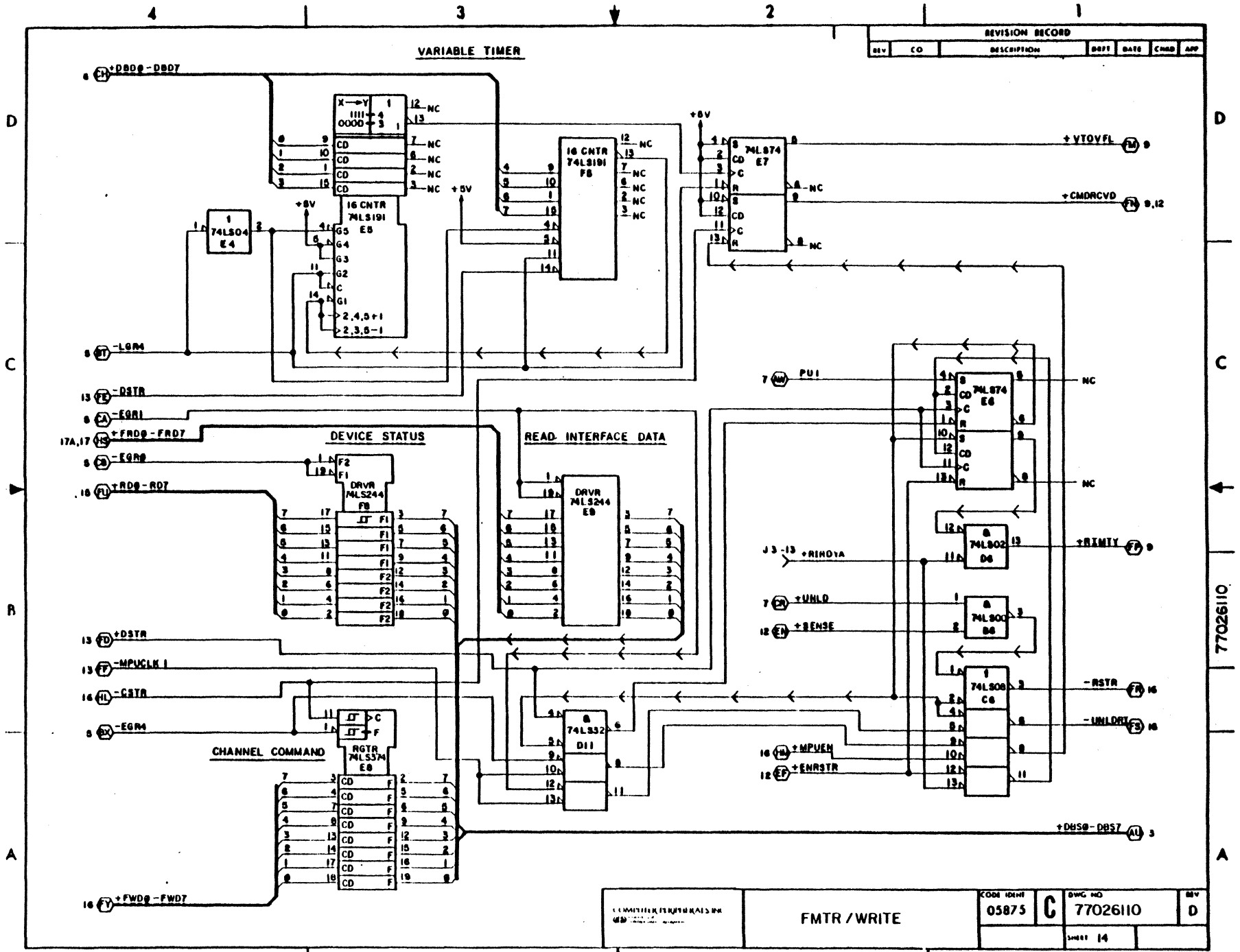

77026110

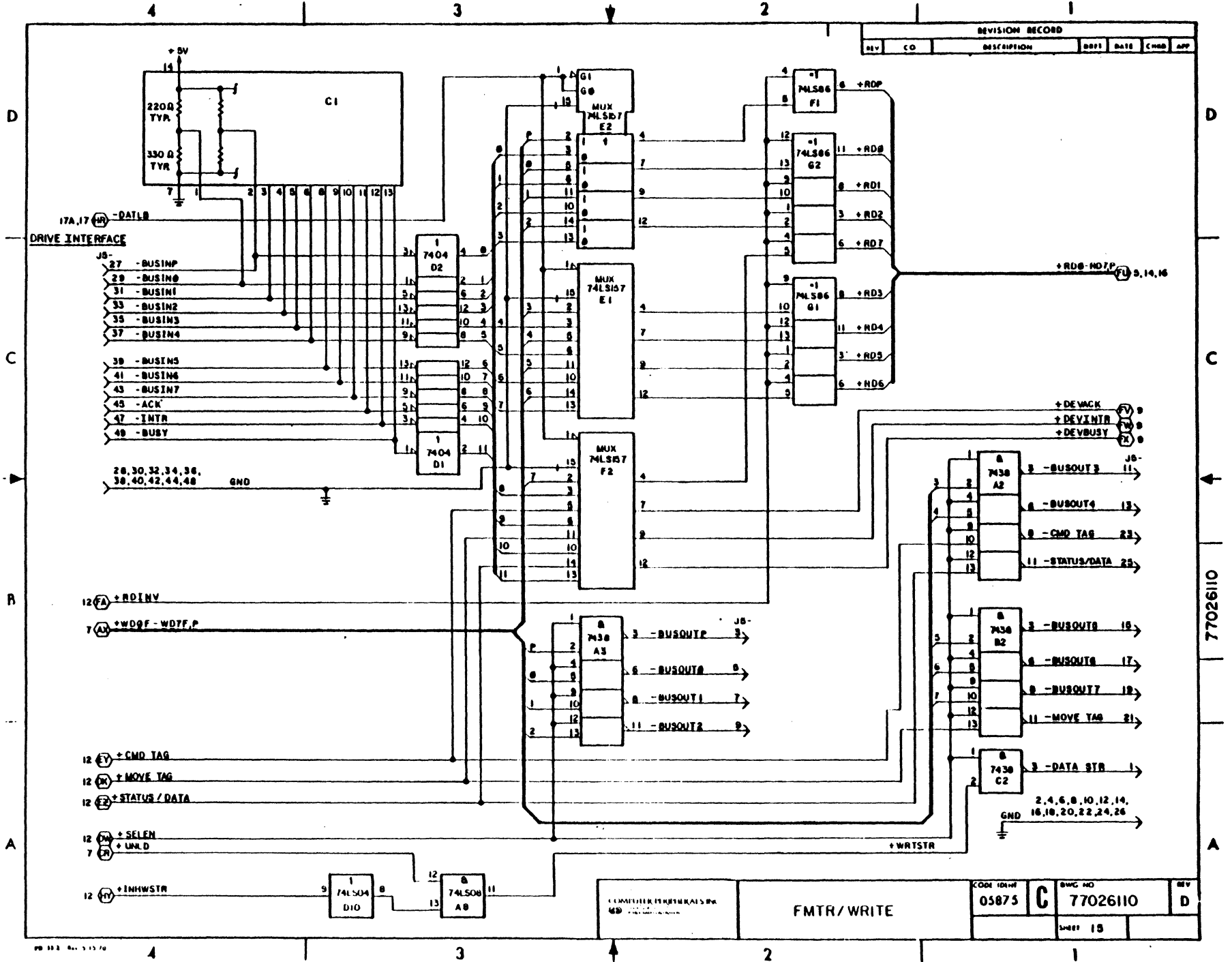

77026110

REVISION RECORD						
REV	CD	DESCRIPTION	DESI	DATE	CHNG	APP

SEE SHEET 1 FOR REVISIONS

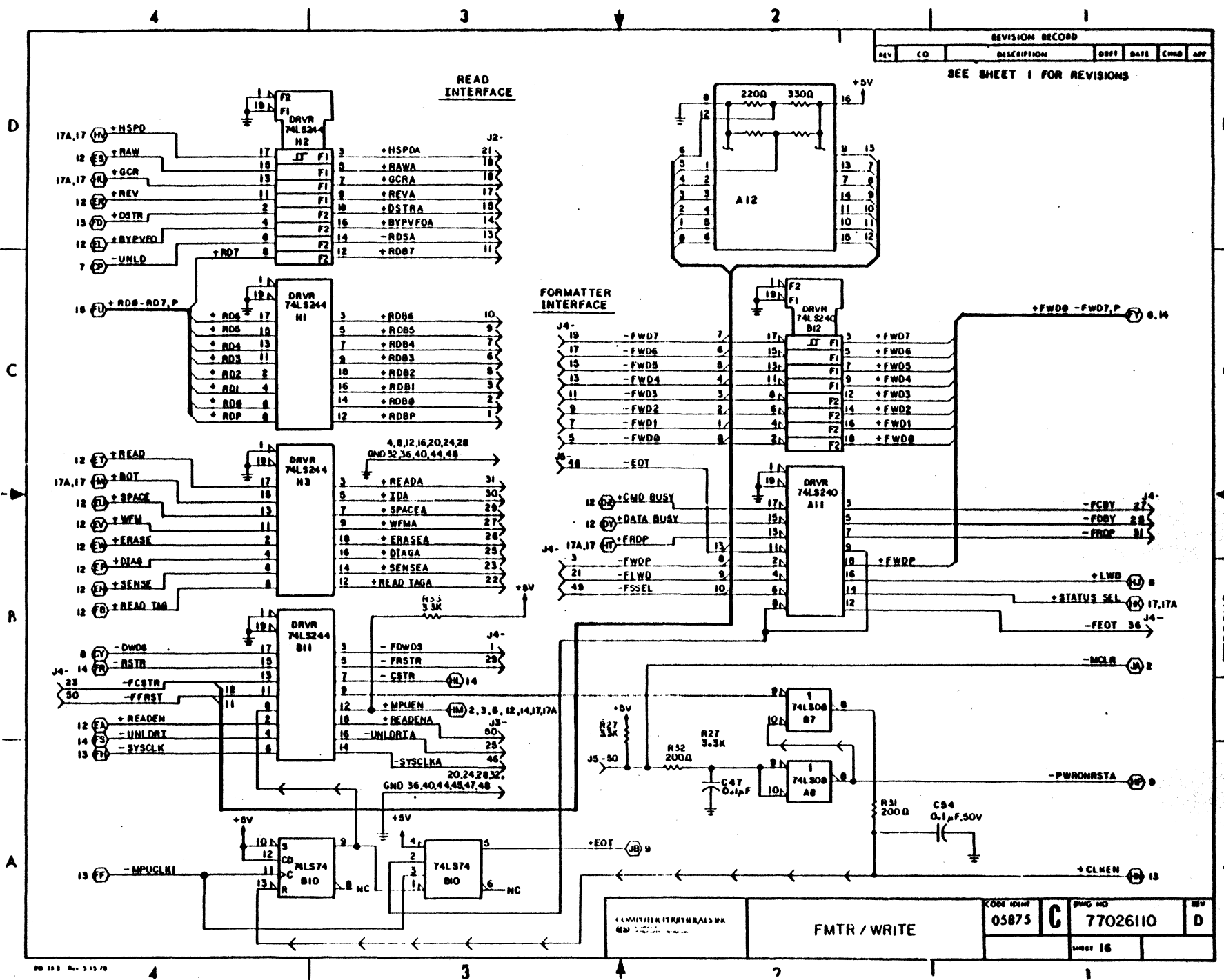

77026110

COMPUTER TERMINALS INC	FMTR / WRITE	CODE 05875	CHNG NO C 77026110	REV D
		SHEET 16		

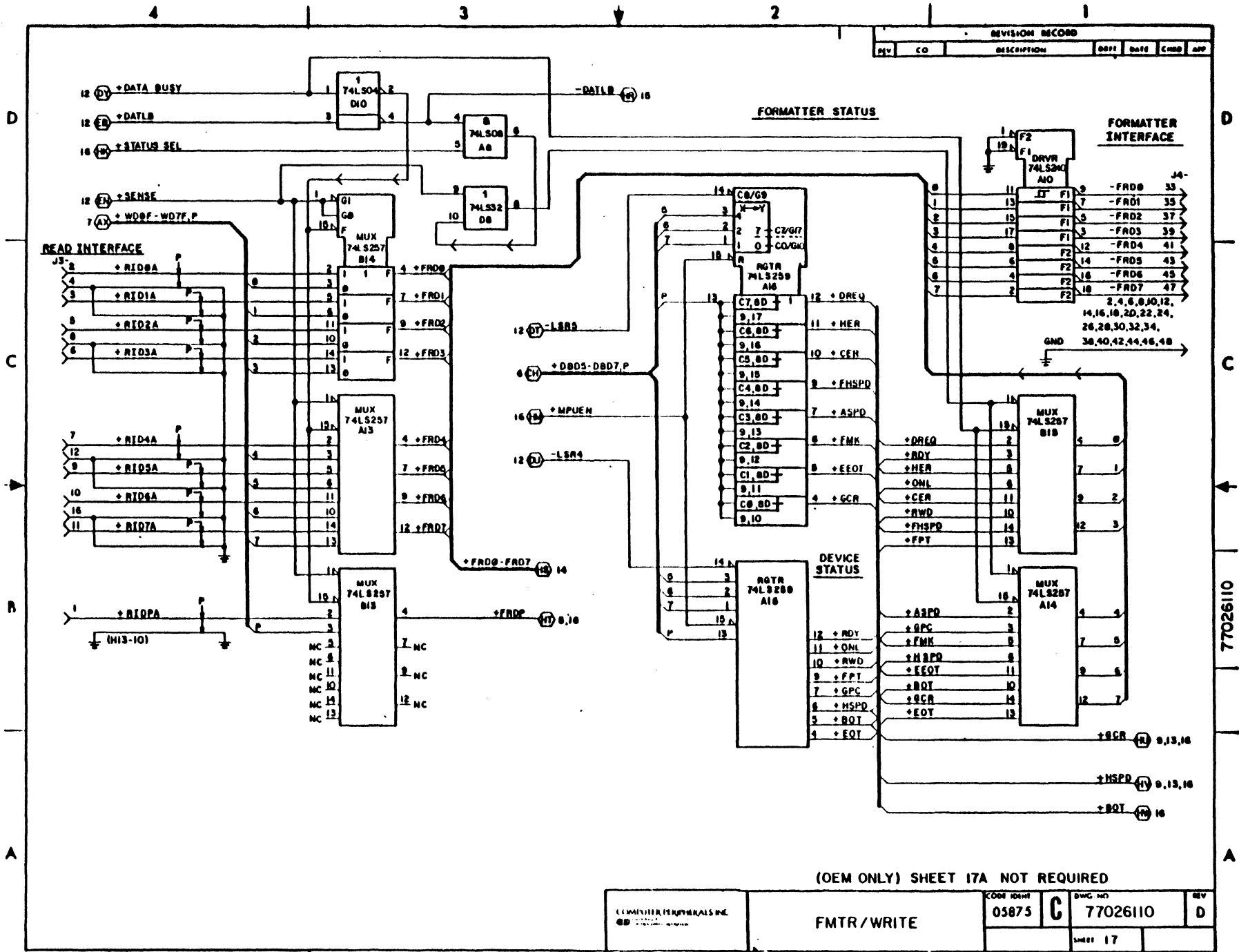

REVISION RECORD					
REV	CO	DESCRIPTION	DATE	CHKD	APP

(OEM ONLY) SHEET 17A NOT REQUIRED

COMPTON PERIPHERALS INC. © 1976	FMTR/WRITE	CODE IDENT	05875	DWG NO	77026110	REV	D
		SHEET	17				

77026110





REVISION RECORD					
REV	CD	DESCRIPTION	DATE	CHKD	APP

SEE SHEET 1 FOR REVISIONS

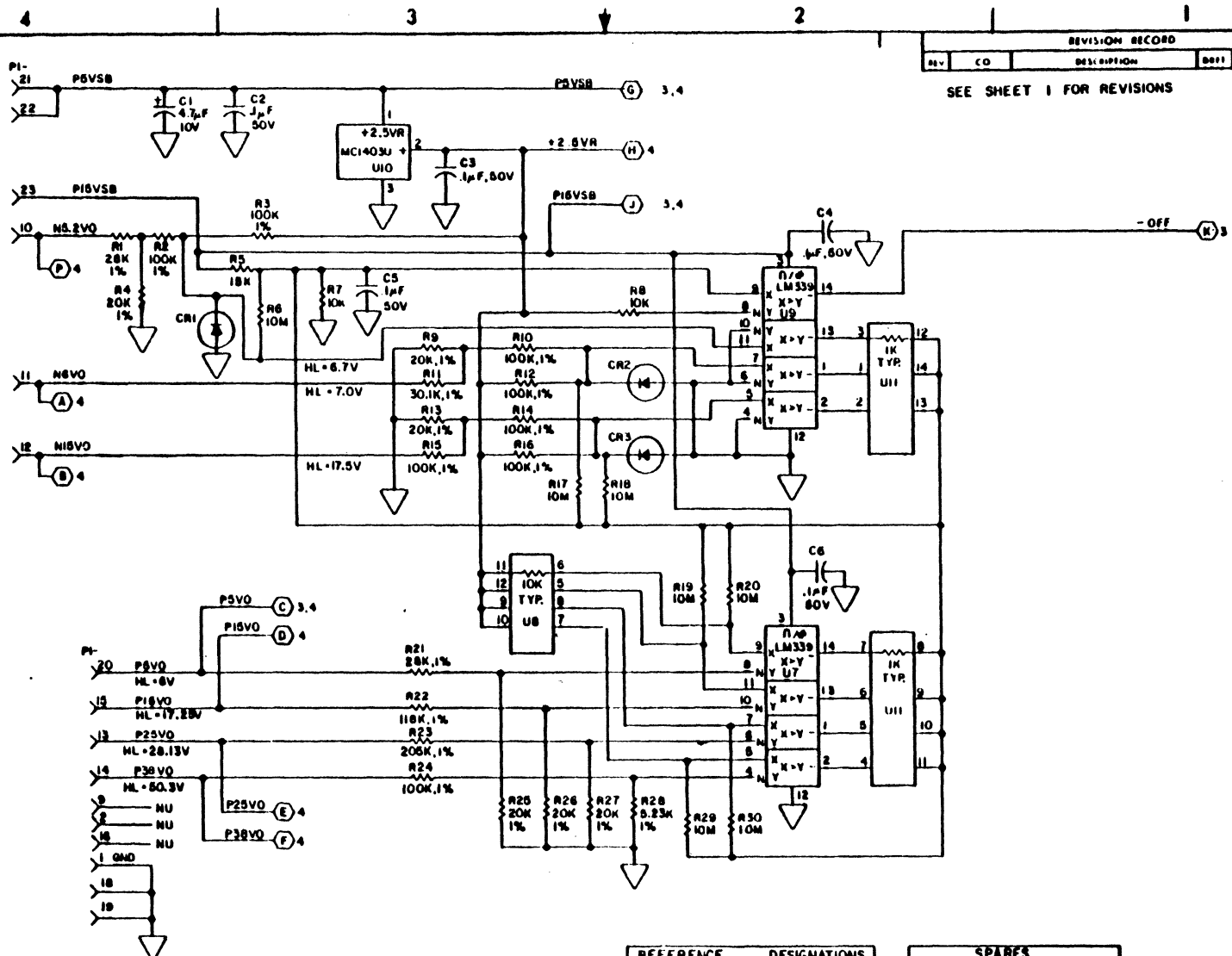

- NOTES:**
1. ALL RESISTORS ARE 1/4W, 5% UNLESS OTHERWISE SPECIFIED.
  2. ALL DIODES ARE IN4148 UNLESS OTHERWISE SPECIFIED.

REFERENCE	DESIGNATIONS
LAST USED	NOT USED
U10	
R93	
C23	
CR13	
Ⓢ	
SW1	

SPARES		
TYPE	LOCATION	OUTPUTS

COMPUTER PERIPHERALS INC.	PWA POWER SUPPLY CONTROL	CODE 1144 05875	REV NO 77041280	REV E
			SHEET 2	

77041280

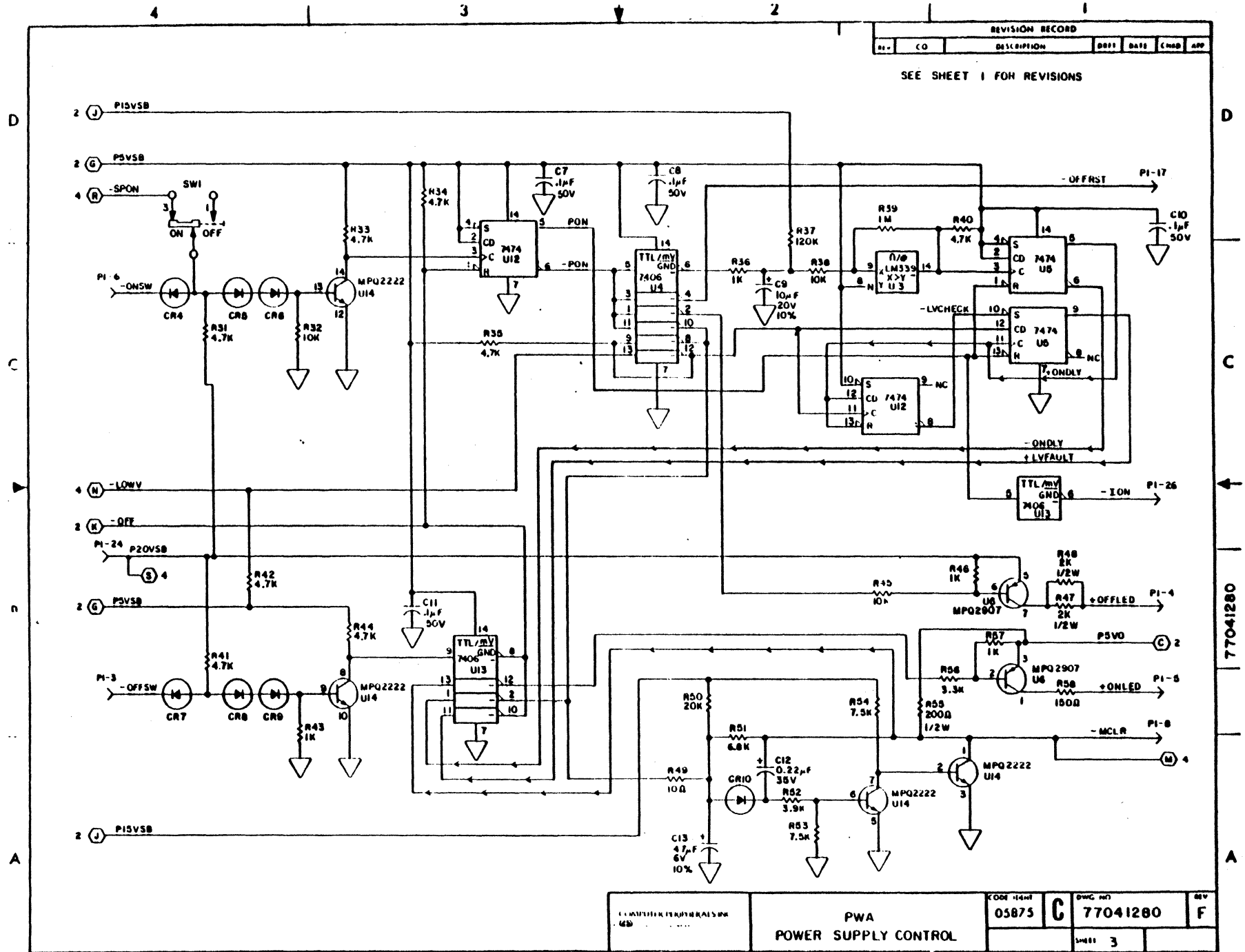

REVISION RECORD				
REV.	CO	DESCRIPTION	DATE	BY

SEE SHEET 1 FOR REVISIONS

49763000 K PWA POWER SUPPLY CONTROL	CODE 1444 <b>05875</b>	DWG NO <b>77041280</b>	REV <b>F</b>
	SHEET	3	

77041280

49763000 K

5-87

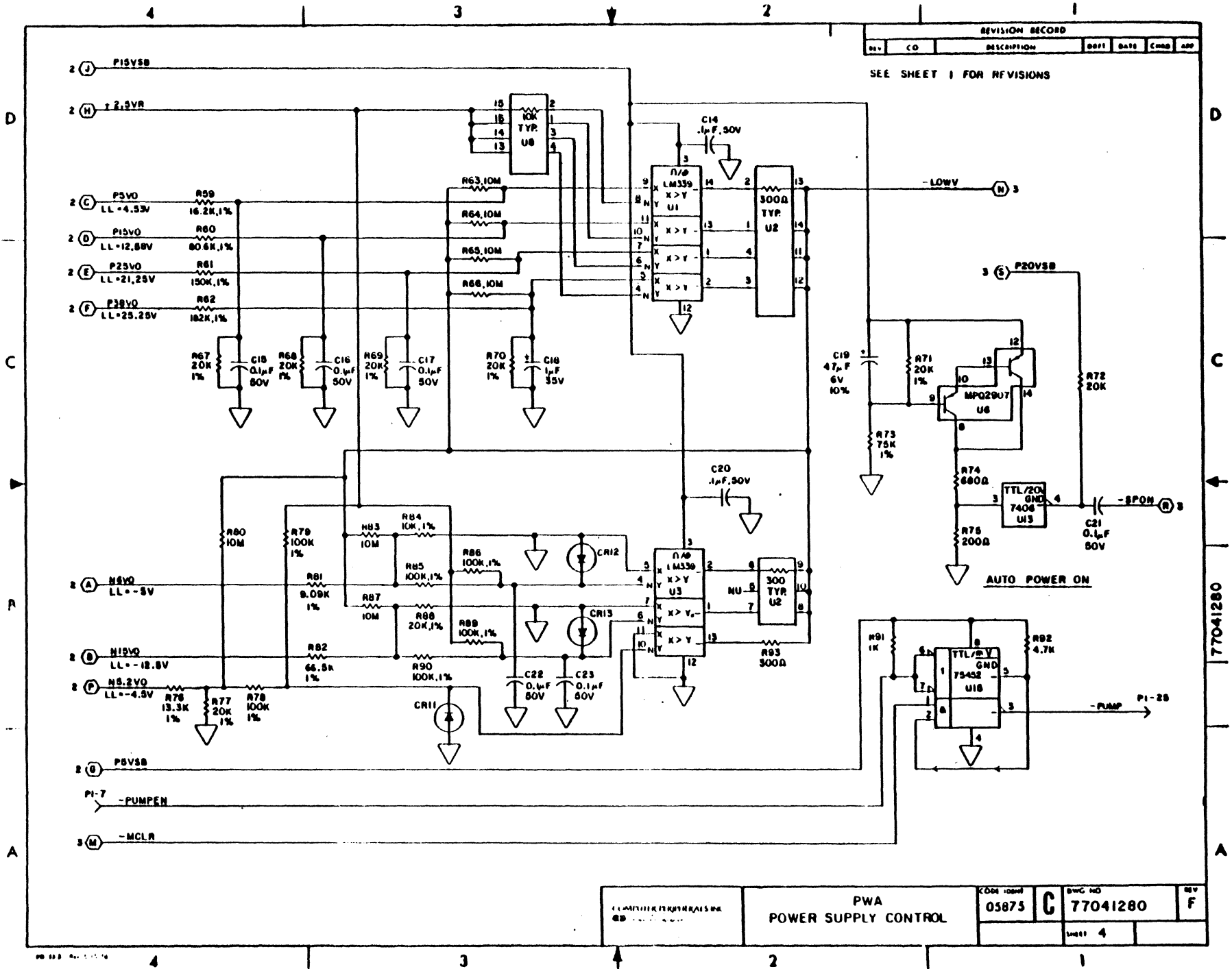

77041280

POWER SUPPLY PWA 77041310

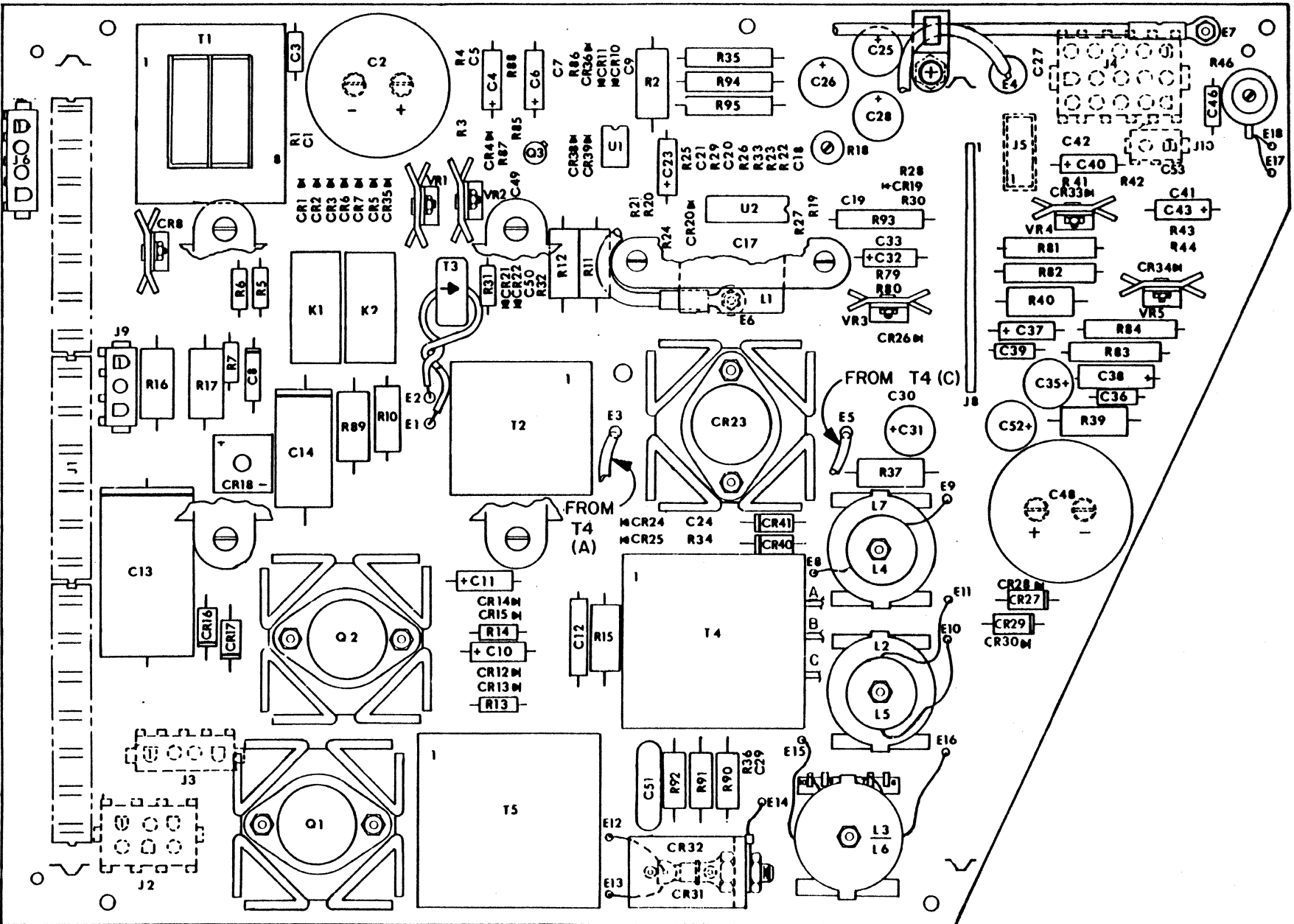

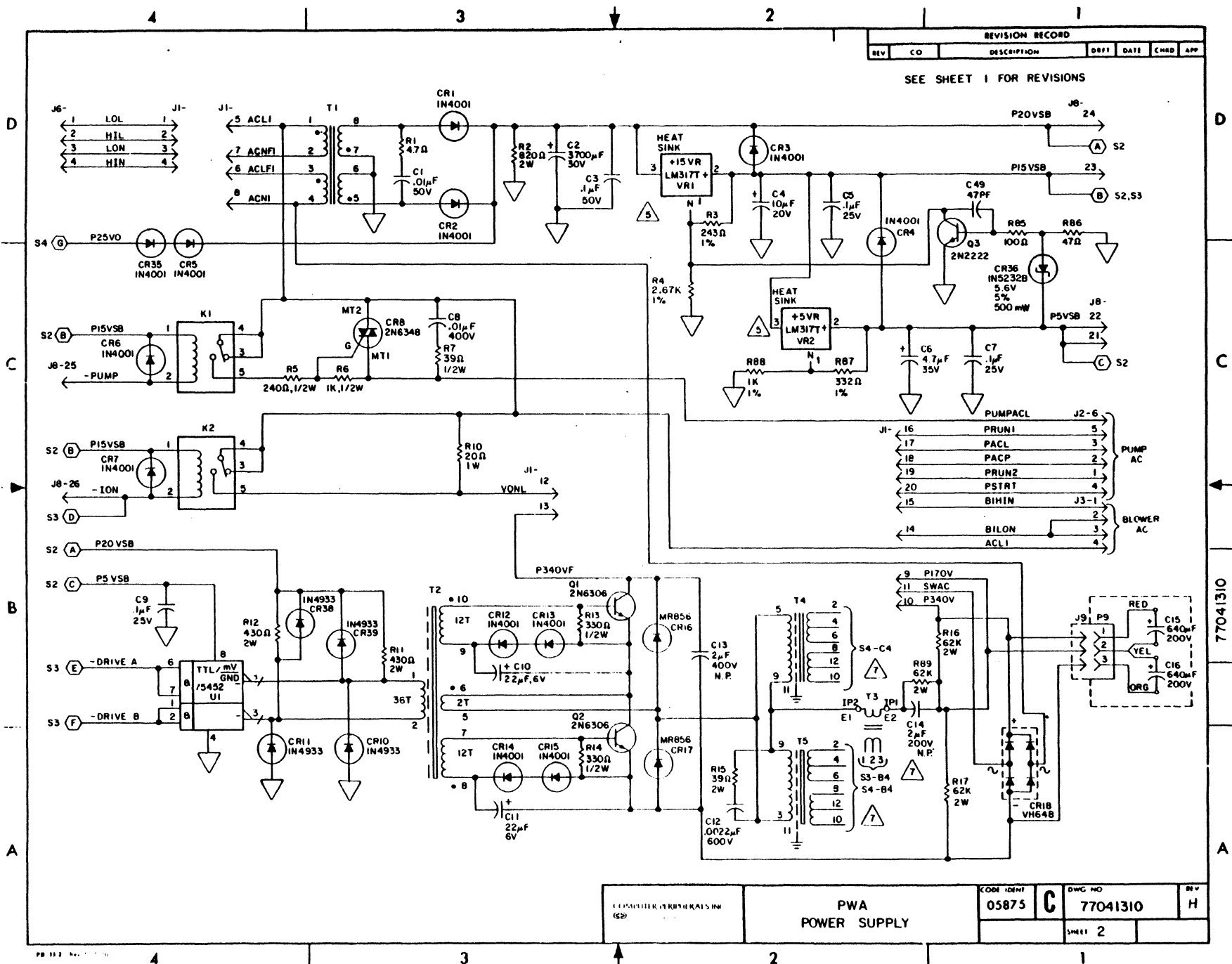

COMPUTER PERIPHERALS INC 629	PWA POWER SUPPLY		CODE IDENT 05875	DWG NO 77041310	REV H
			C	SHEET 2	

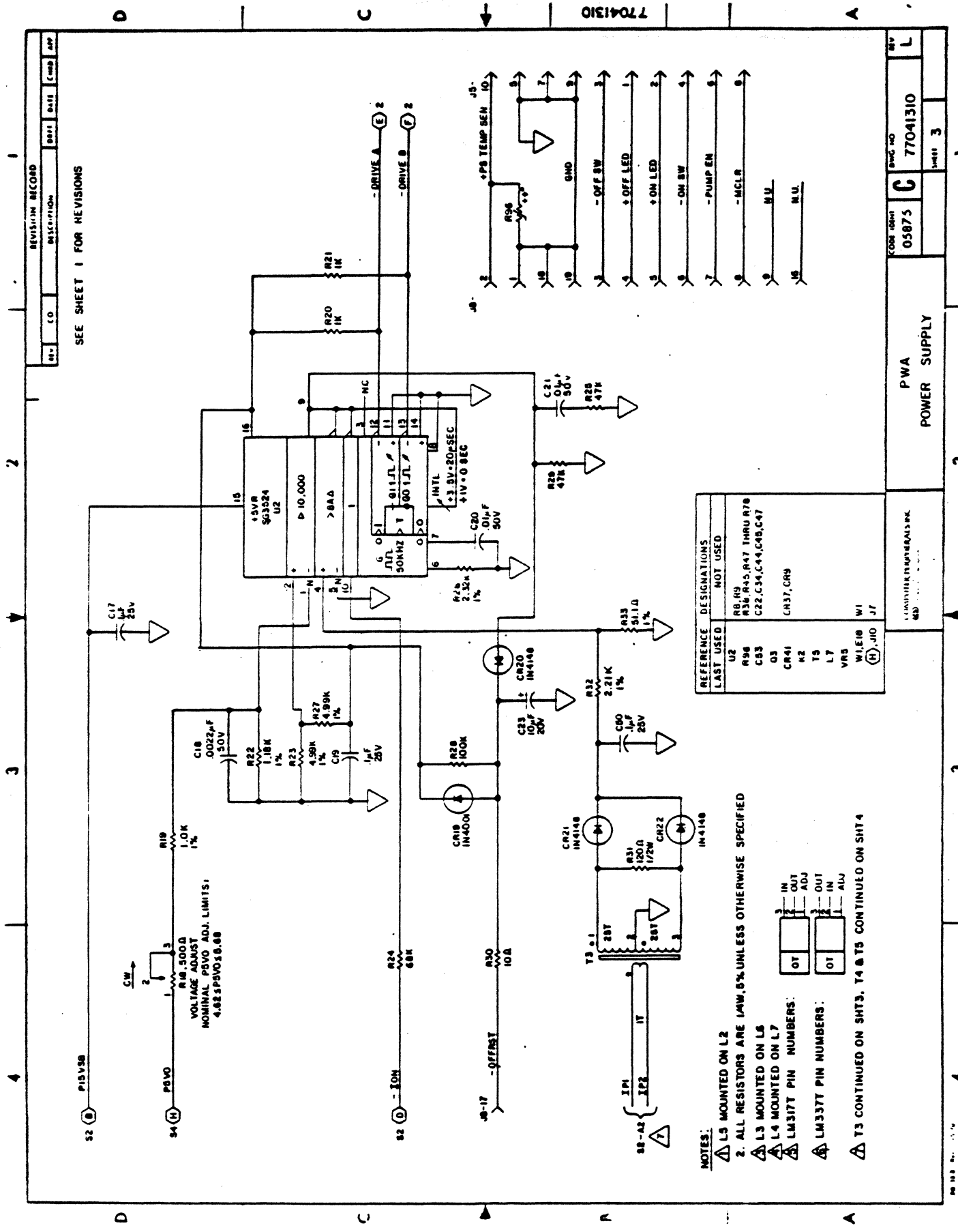

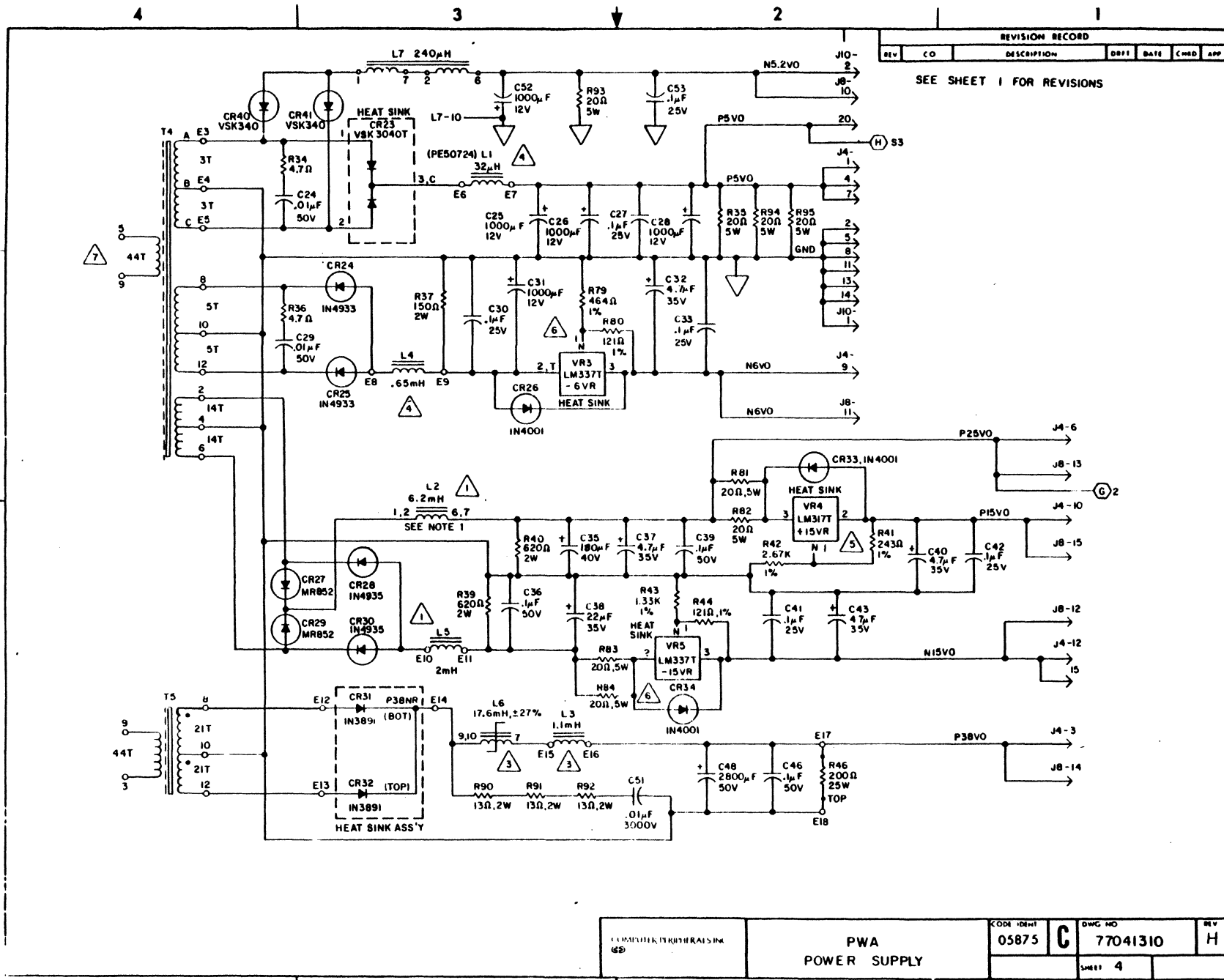

REVISION RECORD					
REV	CO	DESCRIPTION	DATE	CHKD	APP
SEE SHEET 1 FOR REVISIONS					

COMPUTER PERIPHERALS INC 68	PWA POWER SUPPLY	CODE IDENT 05875	DWG NO 77041310	REV H
		SHEET 4		

77041310

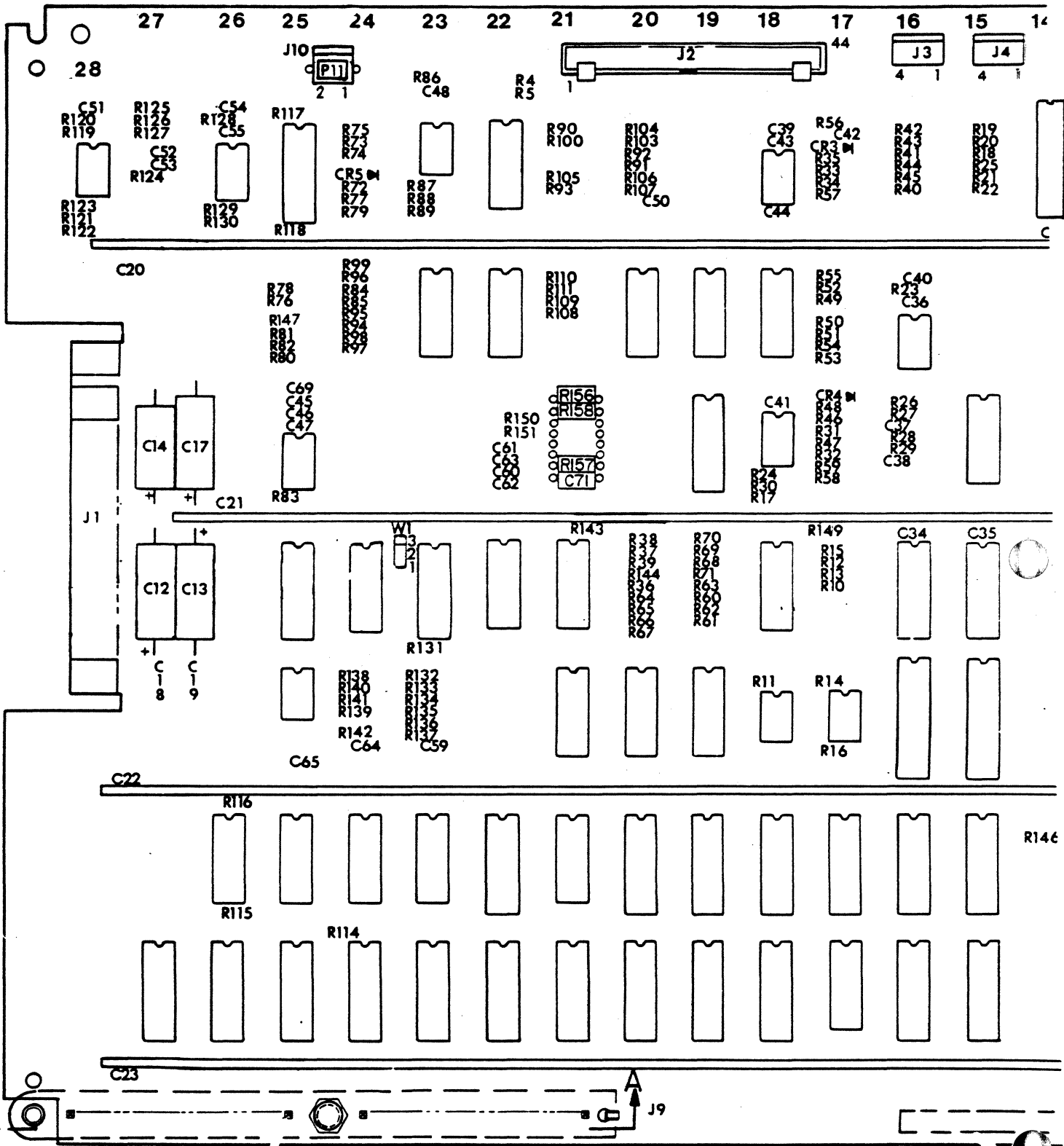

SERVO/CONTROL PWA 77025920

SHEET 1A



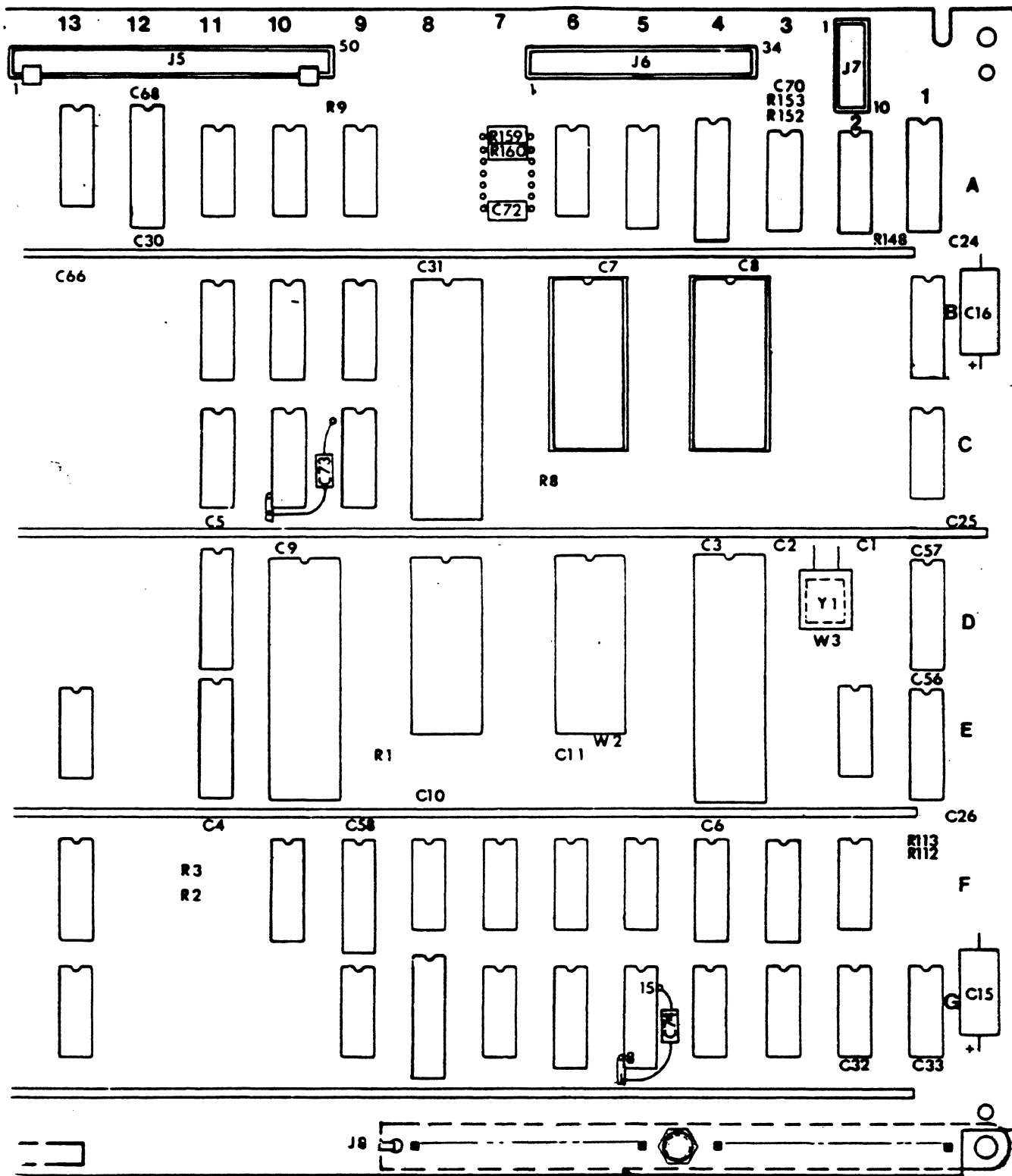

SERVO/CONTROL PWA 77025920

SHEET 1B

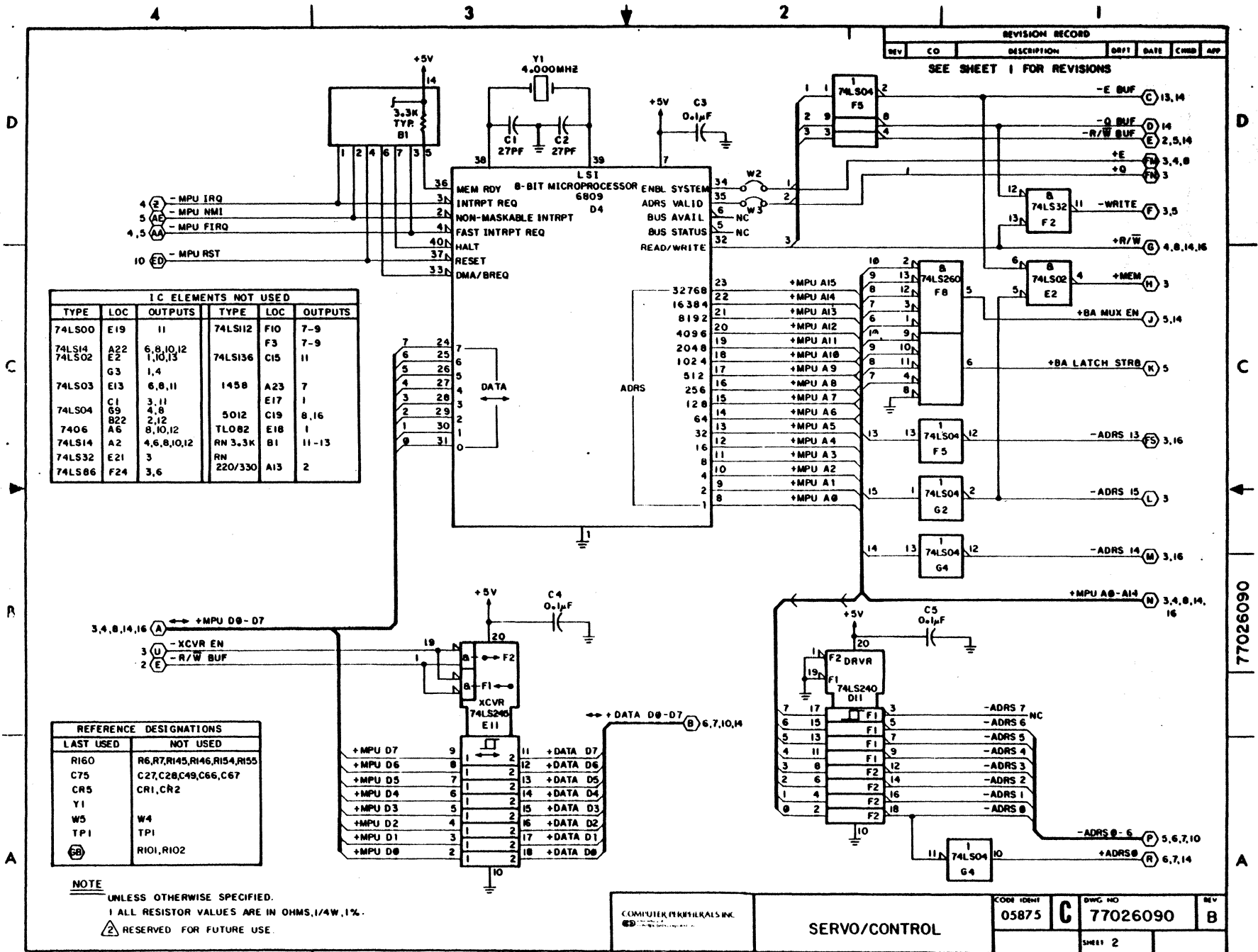

77026090

COMPUTER PERIPHERALS INC.	SERVO/CONTROL	CODE IDENT 05875	DRWG NO 77026090	REV B
			SHEET 2	

REVISION RECORD					
REV	CO	DESCRIPTION	DRFT	DATE	CHNG APP
SEE SHEET 1 FOR REVISIONS					

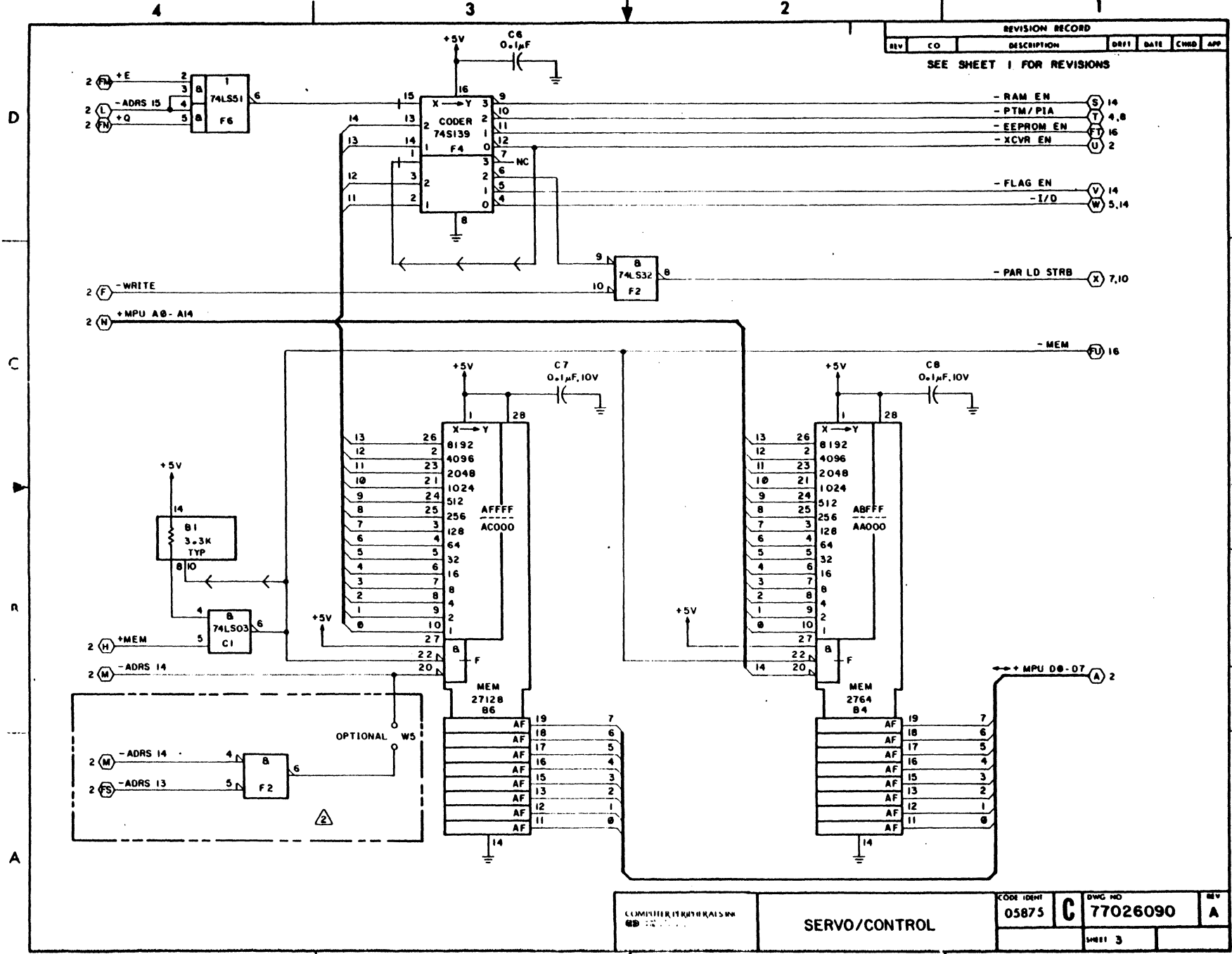

COMPUTER IDENTIFICATION SERVO CONTROL	CODE IDENT	DWG NO	REV
	05875	C 77026090	A
		SHEET 3	

77026090

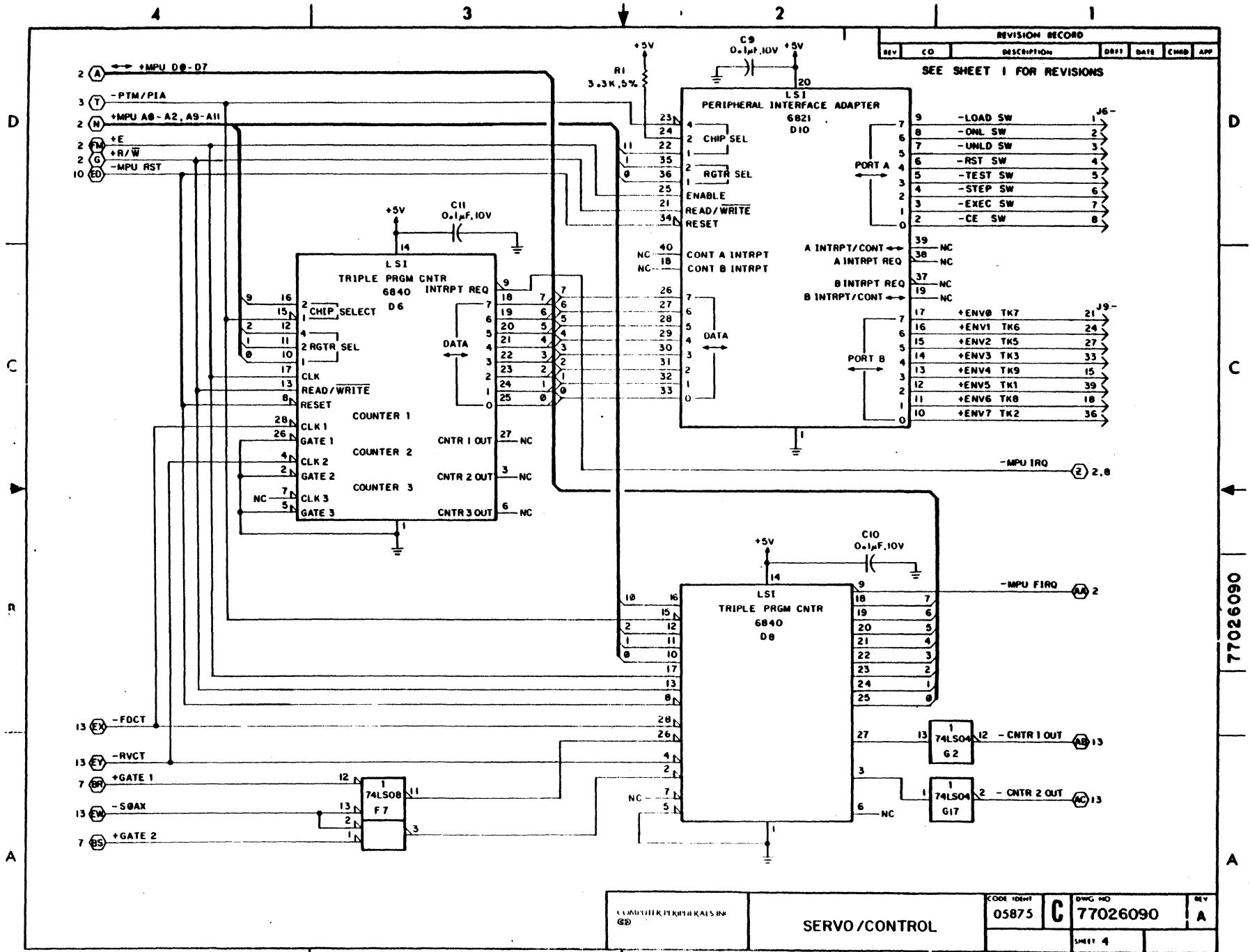

REVISION RECORD						
REV	CD	DESCRIPTION	DRFT	DATE	CMDB	APP
SEE SHEET 1 FOR REVISIONS						

PORT A			PORT B		
9	-LOAD SW	J6-1	17	+ENV0 TK7	J9-21
8	-ONL SW	2	16	+ENV1 TK6	24
7	-UNLD SW	3	15	+ENV2 TK5	27
6	-RST SW	4	14	+ENV3 TK3	33
5	-TEST SW	5	13	+ENV4 TK9	15
4	-STEP SW	6	12	+ENV5 TK1	39
3	-EXEC SW	7	11	+ENV6 TK8	18
2	-CE SW	8	10	+ENV7 TK2	36

COMPUTER PERIPHERALS IN GD	SERVO/CONTROL	CODE IDENT 05875	DWG NO C 77026090	REV A
			SHEET 4	

77026090

REVISION RECORD						
REV	CO	DESCRIPTION	DRFT	DATE	CHNG	APP
SEE SHEET 1 FOR REVISIONS						

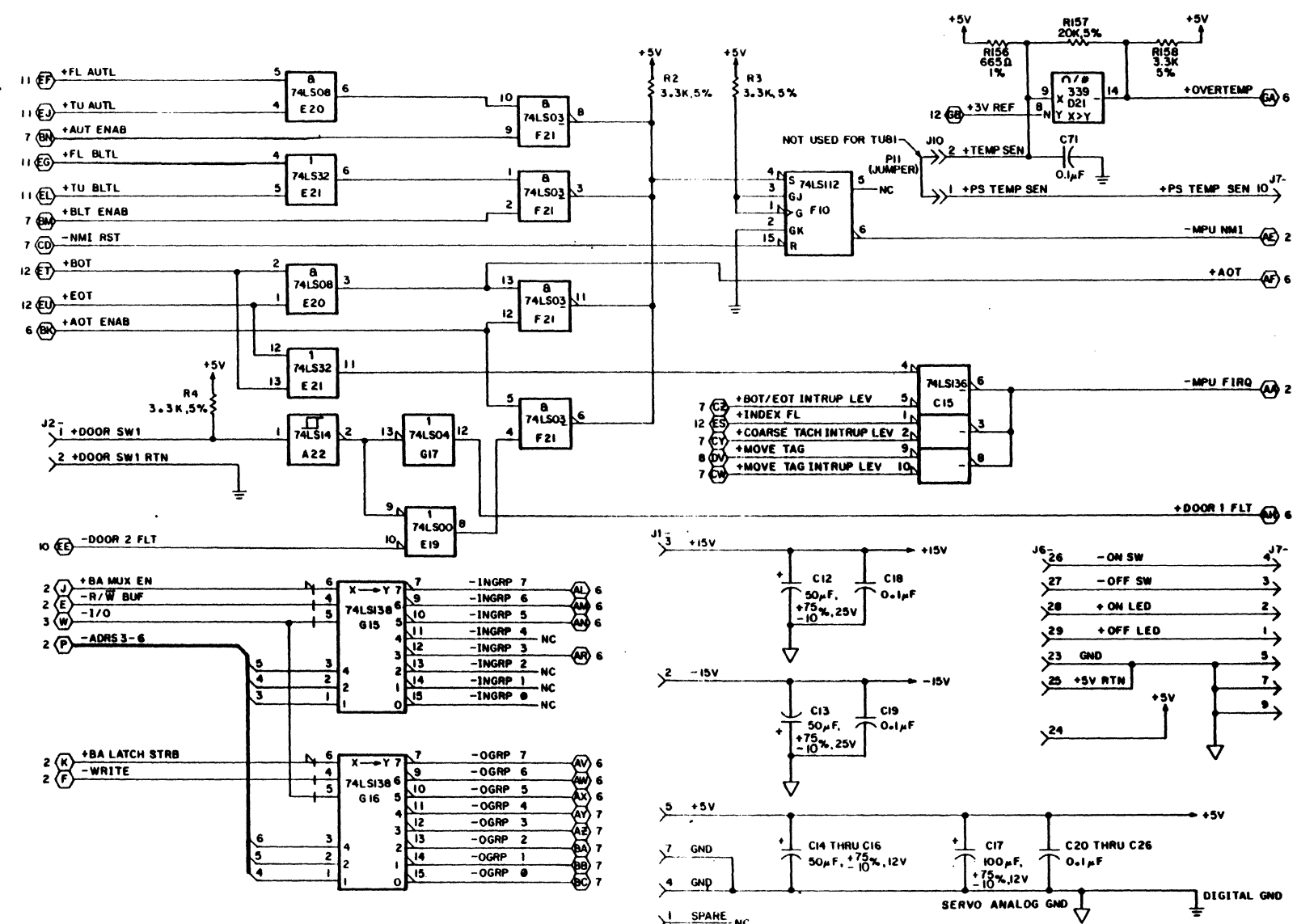

COMPUTER PERIPHERALS INC. GD	SERVO/CONTROL	CODE IDENT	DWG NO	REV
		05875	C 77026090	A
		SHEET 5		

77026090

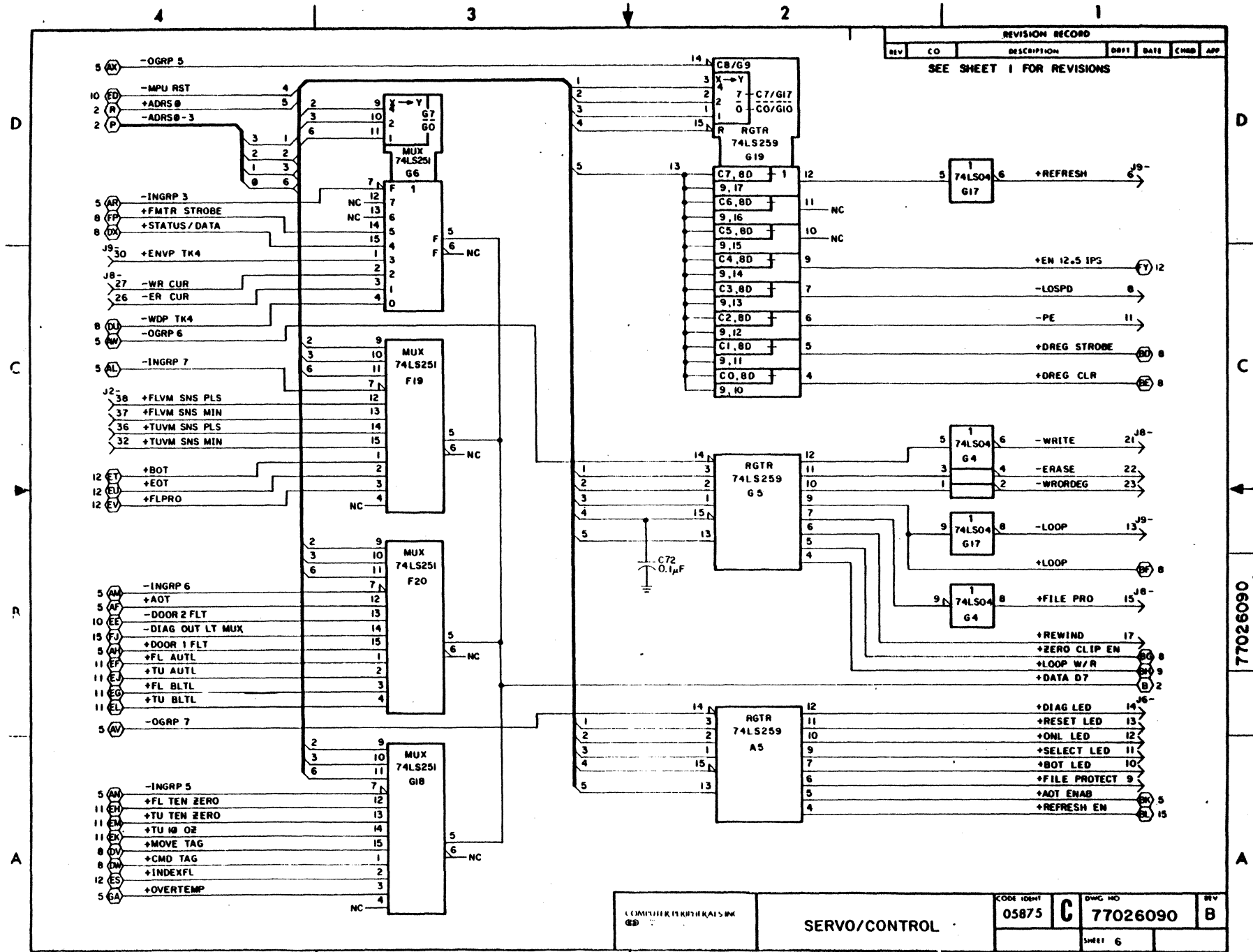

77026090

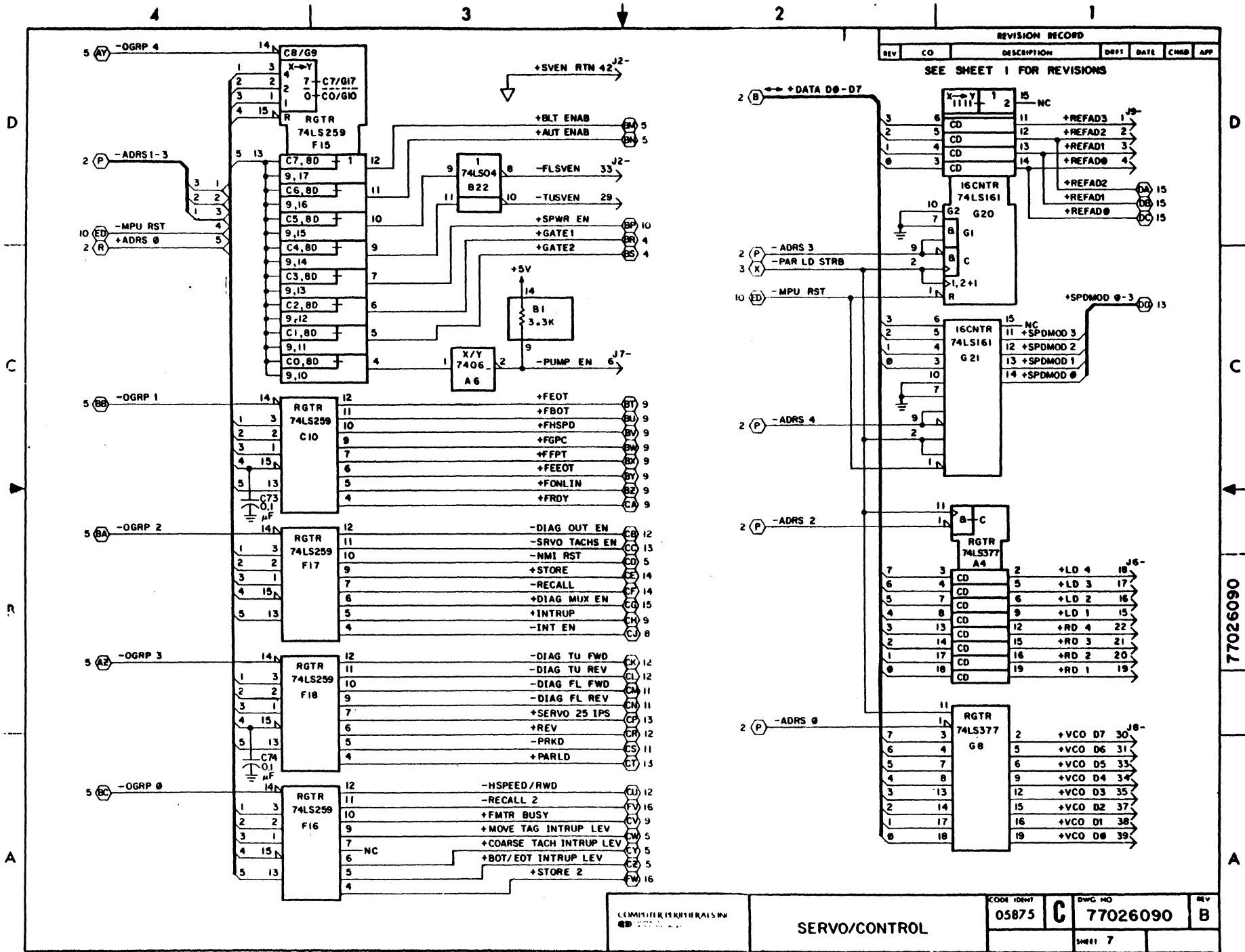

REVISION RECORD						
REV	CD	DESCRIPTION	DRFT	DATE	CHNG	APP
SEE SHEET 1 FOR REVISIONS						

COMPUTER PERIPHERALS INC	CODE IDENT	DWG NO	REV
77026090	05875	C 77026090	B
		SHEET 7	

D  
C  
R  
A

D  
C  
A

4 3 2 1

4 3 2 1

77026090

5-100

49763000 N

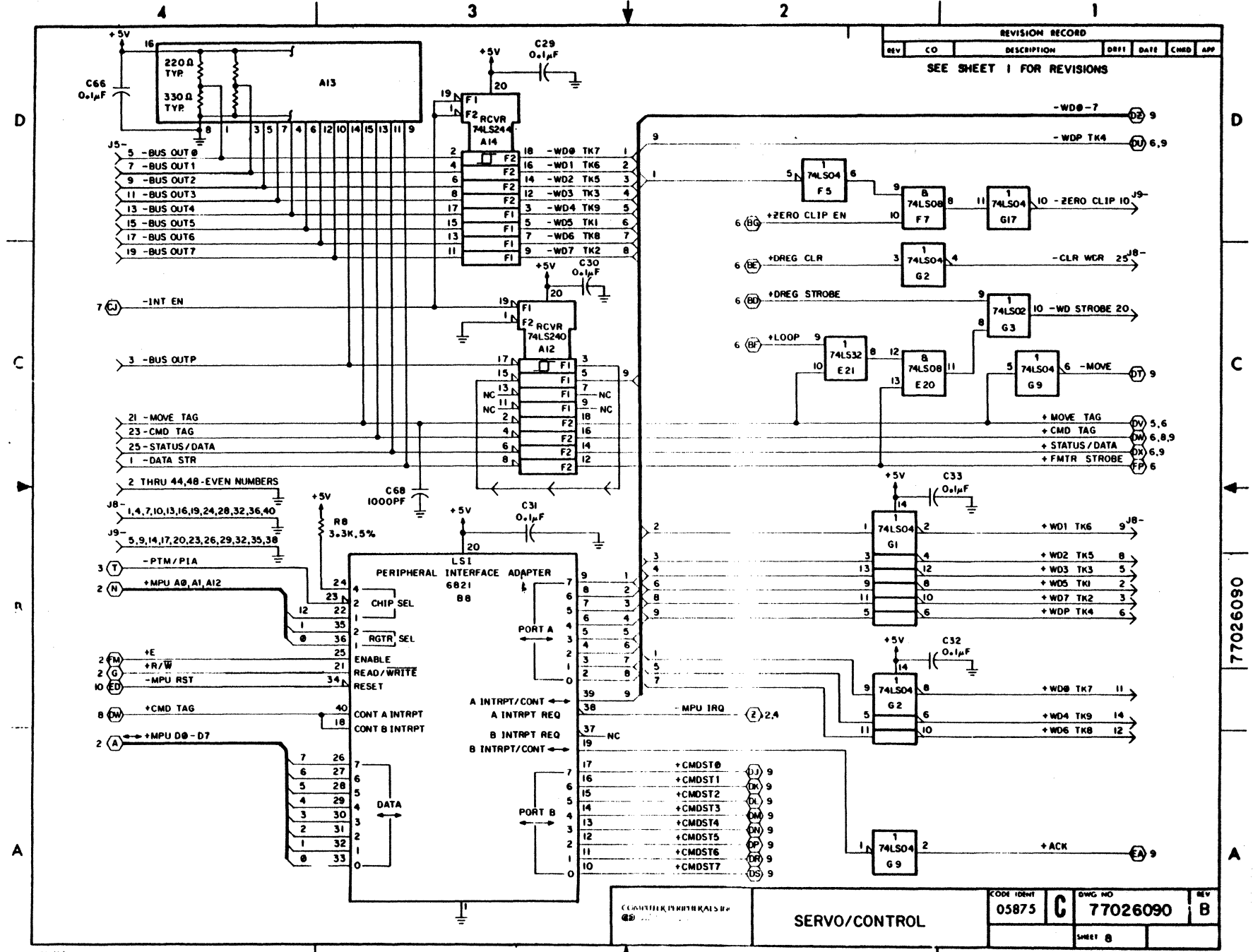

77026090



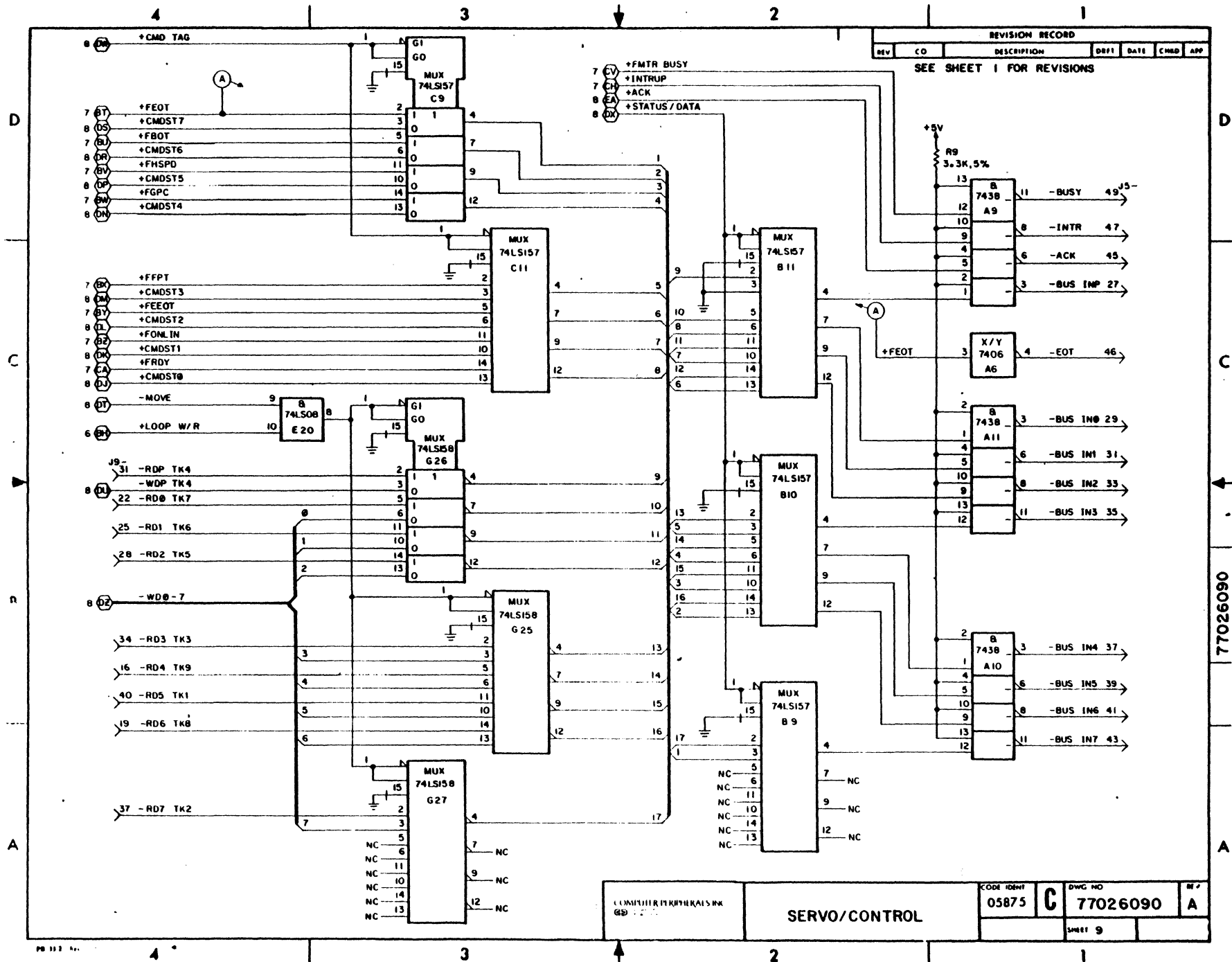

REVISION RECORD						
REV	CD	DESCRIPTION	DEVI	DATE	CMND	APP
SEE SHEET 1 FOR REVISIONS						

COMPUTER PERIPHERALS INC 6811 111	SERVO/CONTROL	CODE IDENT	C	DWG NO	A
		05875		77026090	
		SHEET 9			

77026090

REVISION RECORD						
REV	CO	DESCRIPTION	DRFT	DATE	CHDR	APP
SEE SHEET 1 FOR REVISIONS						

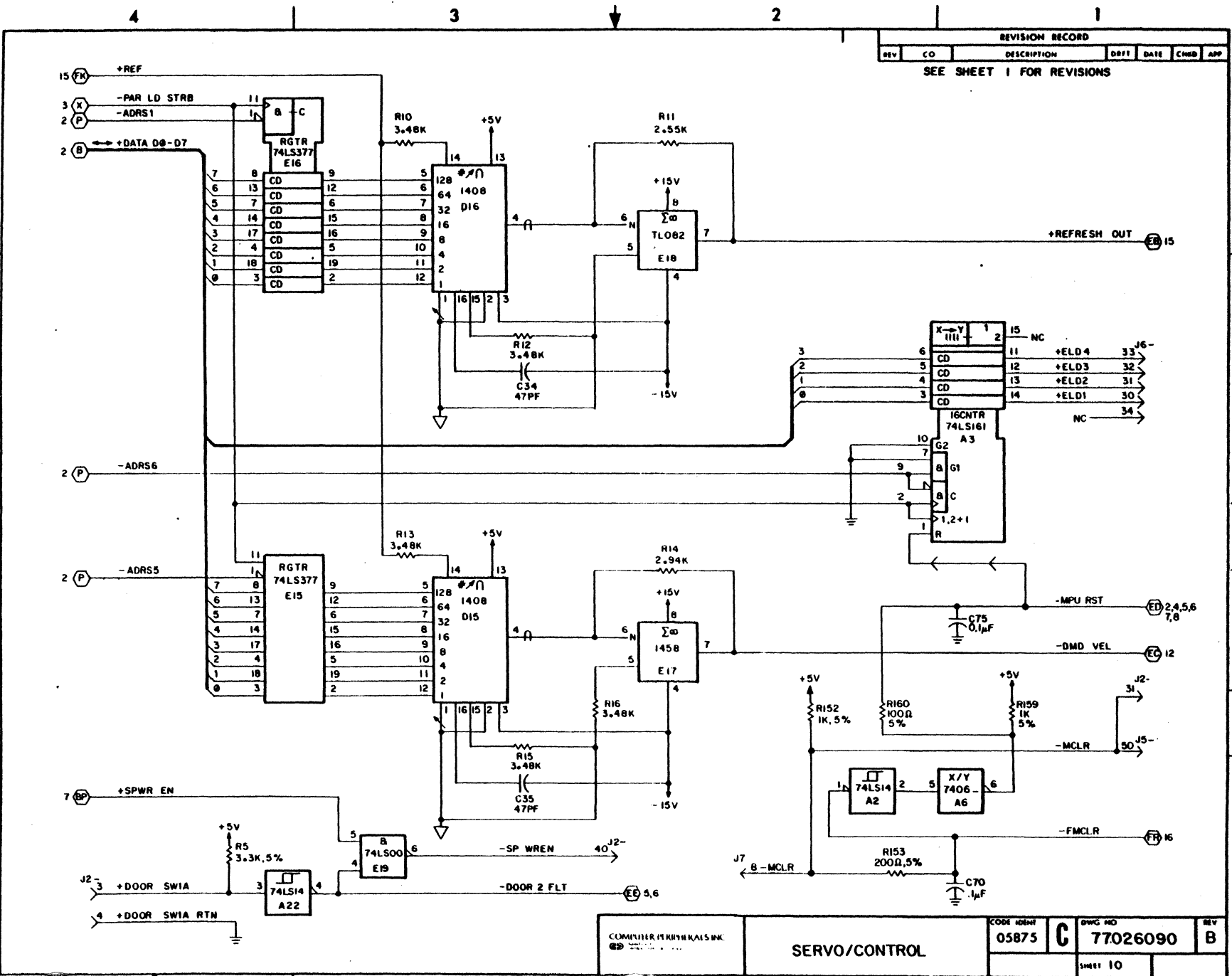

COMPUTER PERIPHERALS INC.	CODE IDENT	DWG NO	REV
	05875	77026090	B
SERVO/CONTROL		SHEET 10	

77026090

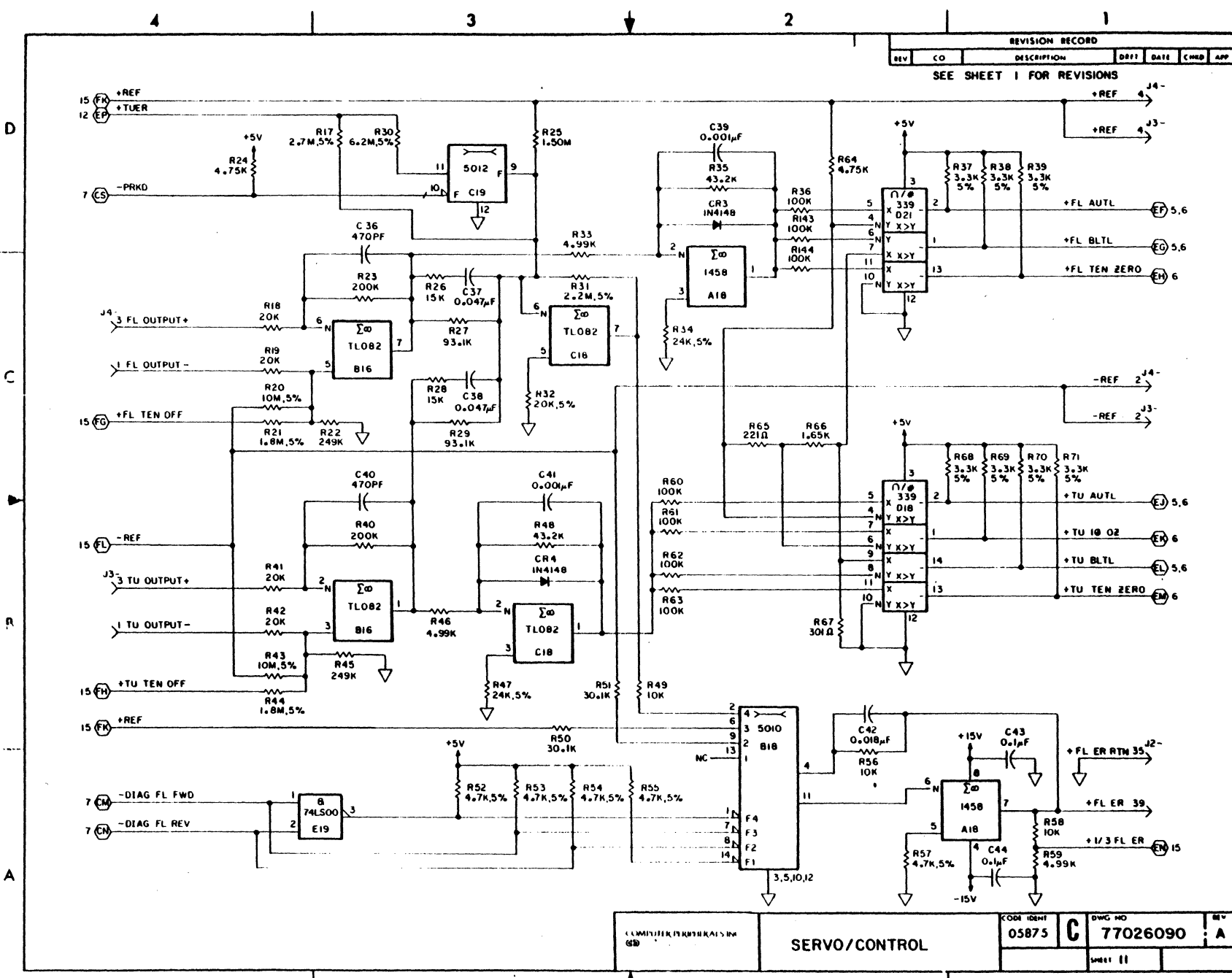

REVISION RECORD						
REV	CO	DESCRIPTION	DR11	DATE	CHWD	APP
SEE SHEET 1 FOR REVISIONS						

UMINIJEKFKRTRKAT15 IN GB	<b>SERVO/CONTROL</b>	CODE IDENT 05875	DWG NO <b>C 77026090</b>	SHEET II
-----------------------------	----------------------	---------------------	-----------------------------	----------

REVISION RECORD						
REV	CO	DESCRIPTION	DRFT	DATE	CHNG	APP
SEE SHEET 1 FOR REVISIONS						

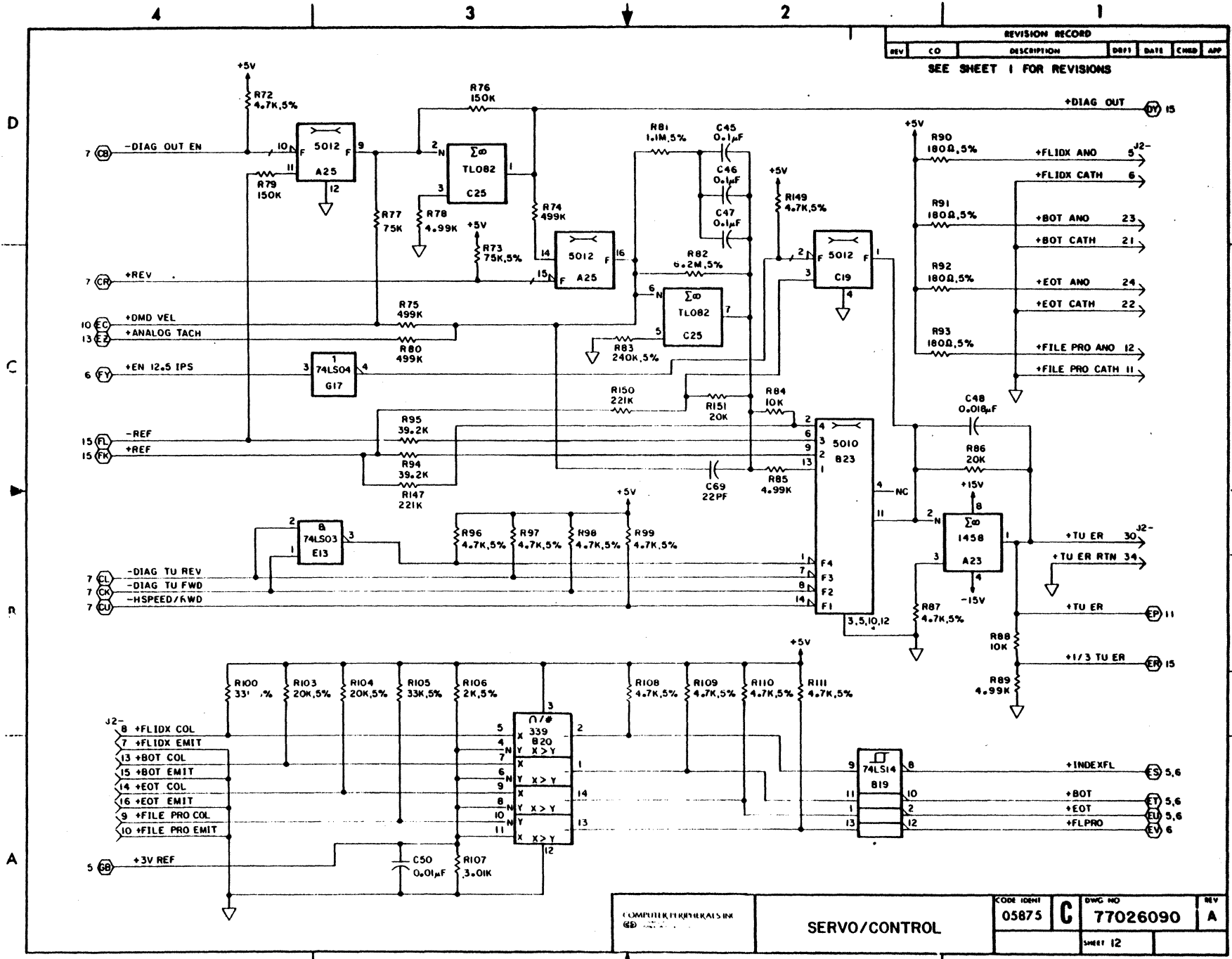

77026090

COMPUTER PERIPHERALS INC	SERVO/CONTROL		CODE IDENT 05875	DWG NO C 77026090	REV A
				SHEET 12	

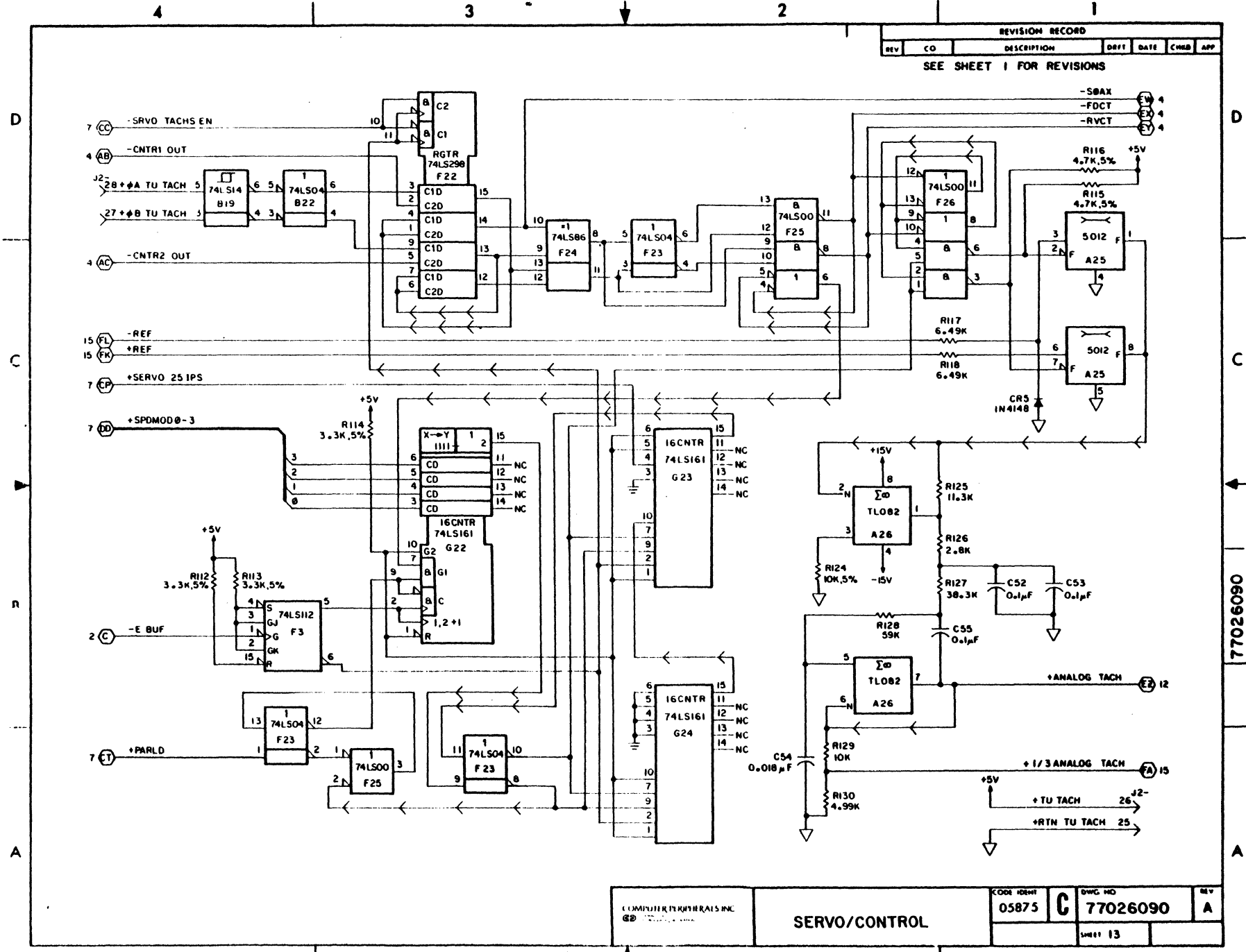

REVISION RECORD						
REV	CO	DESCRIPTION	DRFT	DATE	CHKD	APP
SEE SHEET 1 FOR REVISIONS						

COMPUTER PERIPHERALS INC 62	SERVO/CONTROL	CODE IDENT 05875	DWG. NO. G 77026090	REV A
		SHEET 13		

77026090

REVISION RECORD						
REV	CO	DESCRIPTION	DRFT	DATE	CHNG	APP
SEE SHEET 1 FOR REVISIONS						

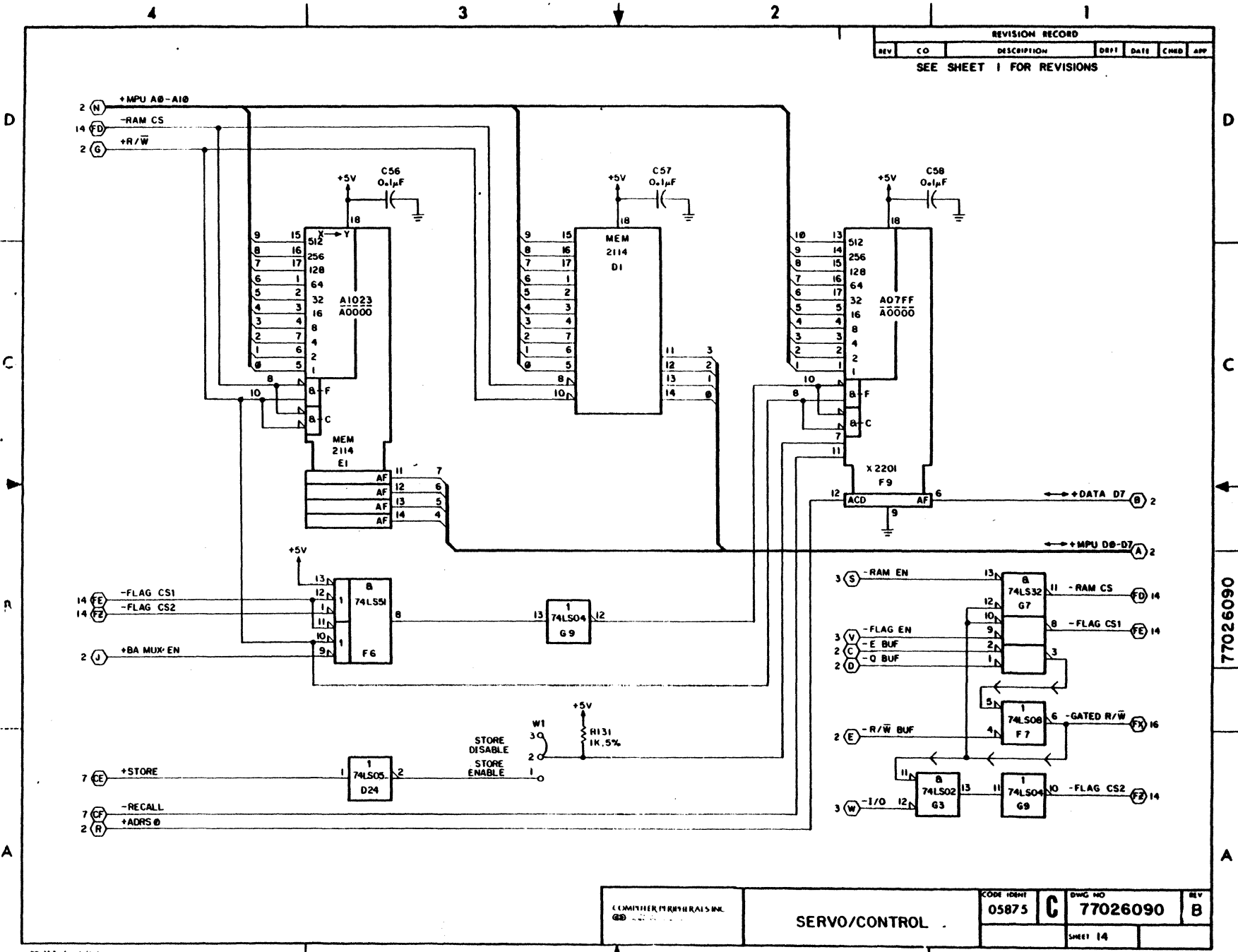

COMPUTER PERIPHERALS INC. GD	SERVO/CONTROL	CODE IDENT 05875	DRWG NO 77026090	REV B
		SHEET 14		

77026090

49763000 H D

C

R

A

5-107

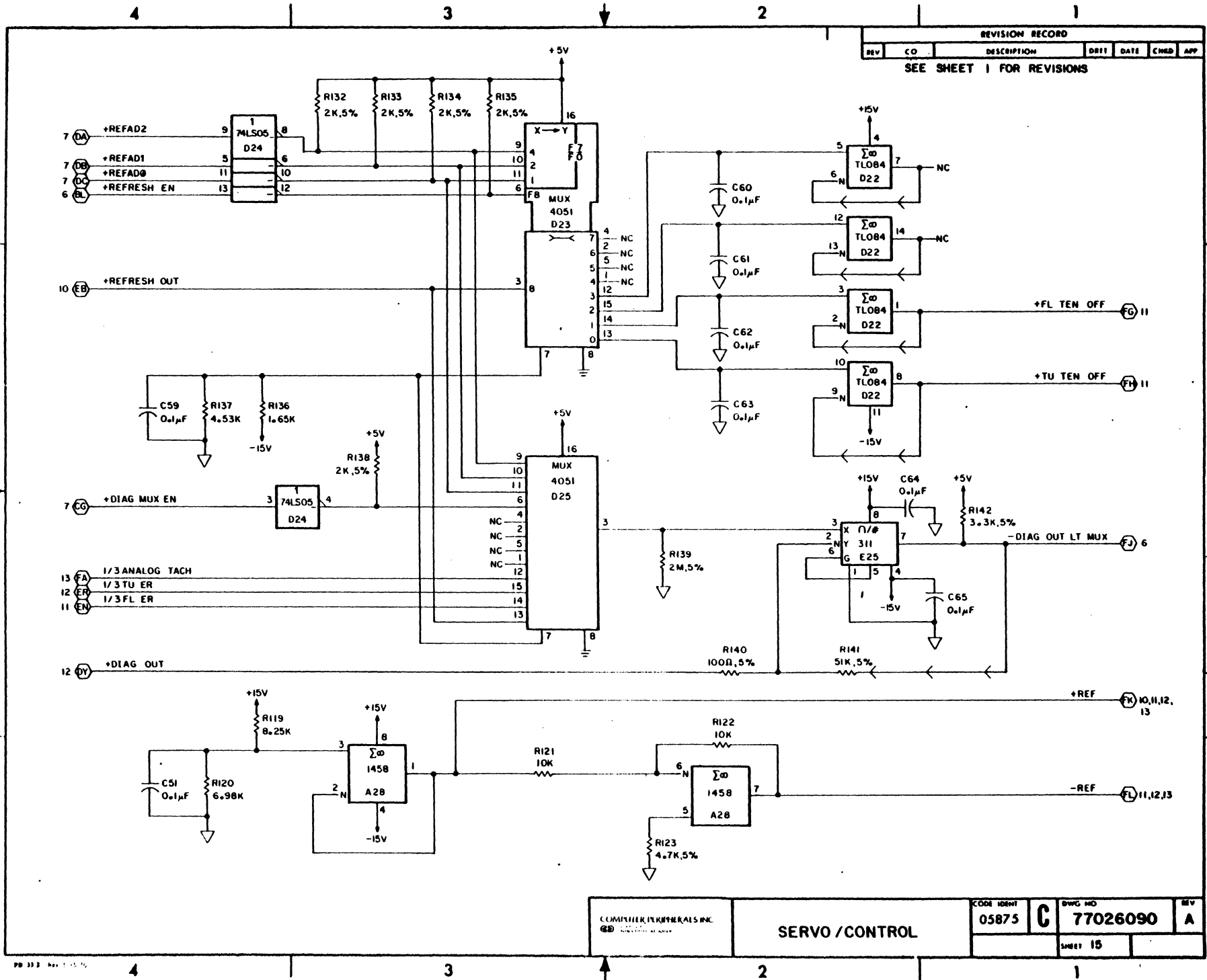

REVISION RECORD						
REV	CO	DESCRIPTION	DRFT	DATE	CHKD	APP
SEE SHEET 1 FOR REVISIONS						

77026090

COMPUTER PERIPHERALS INC.	SERVO / CONTROL	CODE IDENT 05875	SWG NO C 77026090	REV A
			SHEET 15	

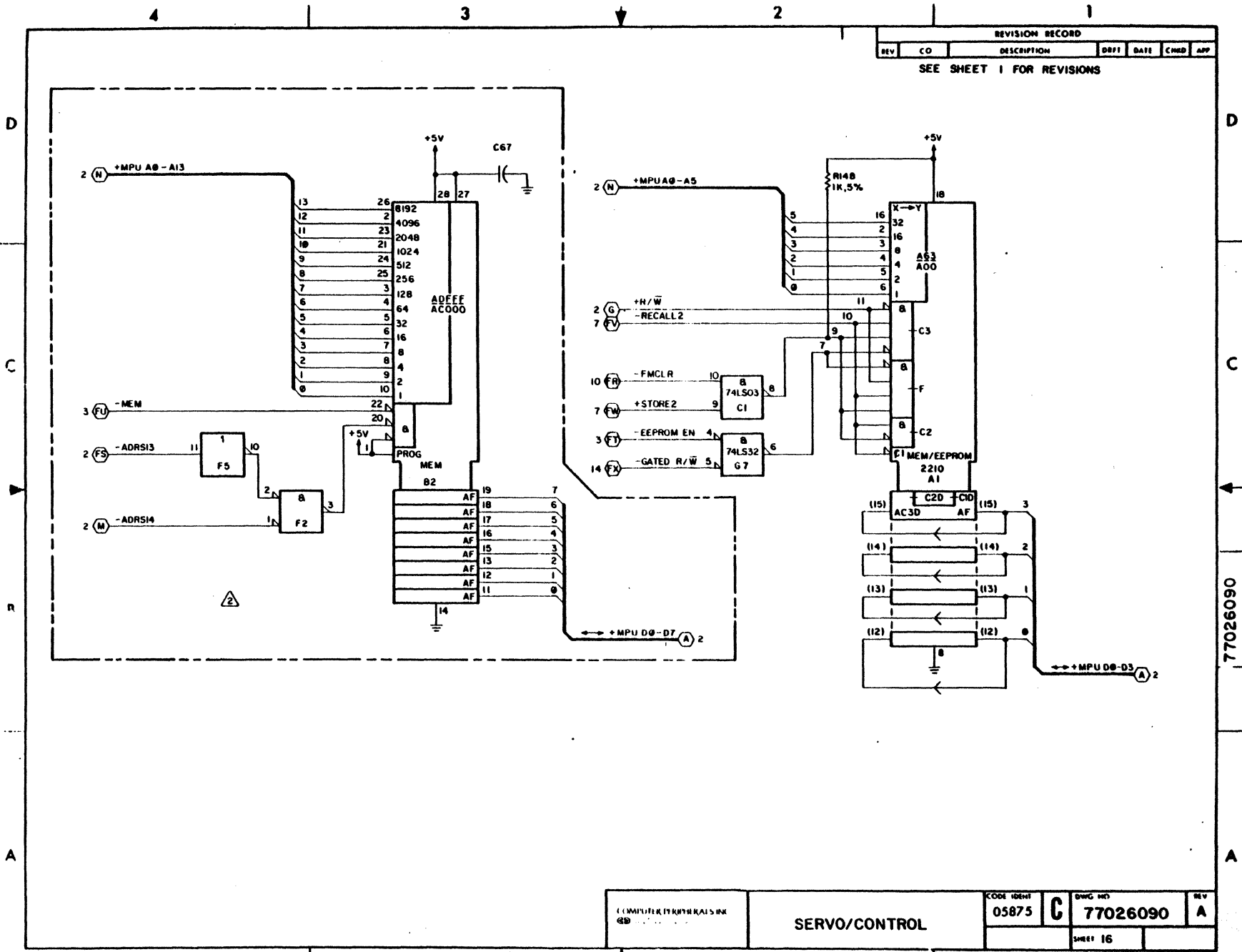

REVISION RECORD					
REV	CD	DESCRIPTION	DDT	DATE	CHKD APP
SEE SHEET 1 FOR REVISIONS					

COMPUTER PERIPHERALS INC 48	SERVO/CONTROL		CODE IDENT 05875	Q	DWG NO 77026090	REV A
			SHEET 16			

77026090



---

## GENERAL DESCRIPTION

In this section, you are furnished with the information needed to identify and remove/replace defective components of the STU. After replacement, test procedures are supplied to verify correct operation. The maintenance philosophy for the STU is that only complete PWAs and assemblies are replaced in the field. Troubleshooting and repair of individual circuit components and sub-assembly parts is not recommended, and therefore, such information is not presented.

The maintenance information is divided into two major areas: trouble analysis, and removal/replacement procedures.

## TROUBLE ANALYSIS

The principles involved in trouble analysis of the STU consist of interpreting fault codes which in the event of failure appear on the diagnostic display on the operator control panel. The trouble analysis section provides information on the operation of the diagnostic portion of the control panel, interpretation of fault codes, description of diagnostic tests, and lists the corrective action to restore the STU to an operable condition.

The trouble analysis information is presented in the following order:

1. CE procedures before arriving at the customer's location (pre-site) and after arrival (on-site).
2. Use of corrective action tables.
3. Diagnostic test information.
4. Structured analysis method (SAM) tables.
5. Functional description of CE tests.

## REMOVAL/REPLACEMENT PROCEDURES

This portion of the maintenance section contains instructions on how to remove and replace all field replaceable parts or assemblies of the STU. Location and identification of assemblies can be found in Section 7 - Parts Identification.

Reference into the removal/replacement procedures is primarily via the structured analysis method (SAM) tables contained in the trouble analysis portion of this section. Verification tests follow each of the replacement procedures so that the integrity of the replaced assembly can be ensured, prior to returning the transport on-line.

Table 6-1. REFERENCED MAINTENANCE AIDS

AID	USED ON
Digital voltmeter 3M777 tape (or equivalent)	Voltage checks Magnetic head replacement Verification check Write driver, read amplifier, and servo-control PWA replacement

# TROUBLE ANALYSIS

## GENERAL INFORMATION

The trouble analysis information consists of diagnostic test procedures, structured analysis method (SAM) tables, and a description of the diagnostic tests.

### NOTES

1. The procedures contained in this section of the manual are addressed to and intended for use by a qualified customer engineer, familiar with the operation of the streaming tape unit (STU). Under no circumstances should these procedures be performed by persons other than fully qualified maintenance personnel.
2. The operator diagnostic procedures referenced in this section of the manual are expanded for maintenance personnel use. Diagnostics for use by the operator are contained in the OPERATION section of Volume I, 49762900.

The diagnostic tests designed into the STU are functions that can be initiated through the operator control panel or on-line by the host. The host controller is capable of monitoring STU status through the STATUS TRANSFER command. A CHANNEL LOOPBACK command is also provided to exercise the interface logic of the STU.

Even when not running diagnostics, the microprocessor tests for many operational fault conditions while operating on-line. These conditions are indicated by fault codes appearing on the control panel display. The fault condition is indicated by the lighting of the RESET indicator and the appropriate fault code being displayed. Faults which occur while tape is loaded may initiate a controlled removal by the microprocessor of servo and write circuitry power to prevent tape damage.

## CUSTOMER ENGINEER PROCEDURES

Your trouble analysis procedures consist of a pre-site analysis of the reported problem, and on-site procedures to isolate and correct verified faults.

### PRE-SITE PROCEDURES

When the trouble call is received from the site, proceed as follows:

1. Consult tables 6-2 and 6-3, Corrective Action Matrices, to determine if operator action is required. Some STU malfunctions or fault codes require operator action in the form of visual checks or cleaning. Instruct the operator to perform diagnostic test 01 after corrective actions have been completed.
2. If the fault persists following completion of all operator actions, consult table 6-2 and 6-3 for identification of assemblies related to the reported malfunction or fault code. Take as many of these assemblies as are available to the site to prevent unnecessary call-backs.

### Corrective Action Matrices

The malfunction/failing assembly matrix and fault code/failing assembly matrix (tables 6-2 and 6-3) list malfunctions or fault codes and possible assemblies which may cause the fault condition. The purpose of these tables is to provide you with a list of related assemblies prior to your reporting to the customer site. Assemblies listed under the individual malfunction or fault codes are arranged in a most probable fault order. Also contained on the matrices in tables 6-2 and 6-3 are those actions, listed in sequence (A, B, C), which should be performed by the operator. Verify the performance of these actions before making an on-site call.

In addition to the assemblies listed, the table may direct you to request the operator to perform diagnostic test 02 or test 03. Execution of these tests may help you to isolate the failure to fewer possible assemblies; the tests are especially helpful if an assembly listed in table 6-3 is not immediately available. Test 02 is recommended if diagnostic test 01 ends in fault codes 22, 24, 26, 30, 31 or 36. Tables 6-4 thru 6-8 list possible failing assemblies for test 02 termination codes.

Test 03 is recommended if test 01 ends in fault codes 03, 04, 06, 25, 30, 31, 32, 33, 35, 36, 48 or 52. Tables 6-9 thru 6-19 list possible failing assemblies for test 03 termination codes.

Table 6-2. MALFUNCTION/ASSEMBLY FAILURE MATRIX

AFTER PRESSING THE CIRCUIT BREAKER TO THE 1 POSITION, THE LOGIC OFF INDICATOR DOES NOT LIGHT.

MALFUNCTION

STU DISPLAYS 00 ON POWER UP.

STU POWERS DOWN WHILE IN USE.

OPERATOR PANEL SWITCH DOES NOT OPERATE.

STU OPERATES WITH OPERATOR DOOR OPEN.

FILE PROTECT INDICATOR DOES NOT LIGHT WHEN A WRITE PROTECTED TAPE IS LOADED.

TAKE UP REEL DOES NOT TURN FREELY.

SUPPLY REEL DOES NOT TURN FREELY.

SUPPLY REEL HUB CANNOT BE LATCHED.

EXCESSIVE PNEUMATIC NOISE.

OPERATOR  
CORRECTIVE  
ACTION

ENSURE STU IS PLUGGED INTO A LIVE SUPPLY	A																		
ENSURE OPERATION IS LEGAL				A															
CHANGE TAPE															A				
FAILING ASSEMBLY																			
SERVO-CONTROL	8	1	3	2	2	2													
READ AMPLIFIER	5																		
WRITE DRIVER	4																		
FORMATTER READ	7																		
FORMATTER WRITE	6																		
INTERFACE	9																		
POWER SUPPLY	1	2	1																
POWER DRIVER			2																
OPERATOR PANEL	3			1		3													
COMPRESSOR																			1
PRESSURE REGULATOR																			2
SUPPLY MOTOR/TACH			5											1					
SUPPLY HUB						4							2	1					
TAKE-UP MOTOR/TACH			4										1						
TAKE UP HUB													2						
DOOR SWITCH					1														
FILE PROTECT SENSOR						1													
COOLING FAN	2																		

Table 6-3. FAULT CODE MATRIX

TEST 01 FAULT CODE	0 0	0 1	0 2	0 3	0 4	0 5	0 6	0 7	0 8	0 9	1 0	1 1	1 2	1 3
<b>OPER. CORRECTIVE ACTION</b>														
Test Successful	X													
Latch Hub Correctly													A	
Thread Tape Correctly												A		A
Clean Head/Tape Path/Hubs		A	A	A	A	A	A	A	A					C
Change Tape		B	B	B	B	B	B	B	B					B
Close Door											A			
Install Wr. Protect Ring														
<b>FAILING ASSEMBLY</b>														
Servo-Control		4	4	1	1	4	4	4	4	1	2	2	1	3
Read Amplifier		3	3	8	8	1	2	1	2					
Write Driver		2	2	3	6	3	1	3	1					
Formatter Read				4	4	2	5	2	5	3				
Formatter Write		5	5	7	5	5	6	5	6	2				
Interface														
Power Supply														2
Power Driver				6	3		7							
Control Panel														
Compressor														1
Filter														4
Supply Air Bearing														
Take-Up Air Bearing														
Head (Amplitude Error)		1	1											
Head (Data Reliability)				5	7	6	3	6	3					
Write Cable		6	6	9	9	7	9		7					
Supply Motor/Tach														3
Supply Hub														2
Take-Up Motor/Tach				2	2	8	8							5
EOT/BOT Sensor												1	4	6
Door Interlock Switch										1				
File Protect Sensor														
Pressure Regulator														5
Cooling Fan														
Temperature Sensor														
<b>FUTHER ISOLATION ACTION</b>														
Run Test 02 (See NOTE 1)														
Run Test 03 (See NOTE 1)				X	X		X							

NOTE 1. Run tests 02 and 03 only if test 01 directs their use to further identify the probable failing assembly. For termination code/failing assembly matrix, refer to tables 6-4 thru 6-19.

Table 6-3. FAULT CODE MATRIX (Cont'd)

TEST 01 FAULT CODE	1 4	1 5	1 6	1 7	1 8	2 0	2 1	2 2	2 3	2 4	2 5	2 6	2 7	2 9
OPER. CORRECTIVE ACTION														
Test Successful														
Latch Hub Correctly								A			A			
Thread Tape Correctly				A										A
Clean Head/Tape Path/Hubs								B			B			
Change Tape	A		A	B				C			C			B
Close Door														
Install Wr. Protect Ring			B											
See NOTE 2		X												
FAILING ASSEMBLY														
Servo-Control	2	2	2	1	1	2	2	4	1	3	2	4	1	2
Read Amplifier														
Write Driver														
Formatter Read														
Formatter Write			3	2										
Interface														
Power Supply														
Power Driver								5		1	4	3		
Control Panel		1												
Compressor														
Filter														
Supply Air Bearing						1								
Take-Up Air Bearing							1							
Head (Amplitude Error)														
Head (Data Reliability)														
Write Cable														
Supply Motor/Tach								3	2	2		2	2	
Supply Hub			4					1			1			
Take-Up Motor/Tach								2			3	1		
EOT/BOT Sensor	1													1
Door Interlock Switch												5		
File Protect Sensor			1											
Pressure Regulator														
Cooling Fan														
Temperature Sensor														
FURTHER ISOLATION ACTION														
Run Test 02 (See NOTE 1)								X		X				
Run Test 03 (See NOTE 1)											X	X		

NOTE 1. Run tests 02 and 03 only if test 01 directs their use to further identify the probable failing assembly. For termination code/failing assembly matrix, refer to tables 6-4 thru 6-19.

NOTE 2. Fault can be caused by operator pressing RESET/FAULT switch during LOAD or UNLOAD operation.

Table 6-3. FAULT CODE MATRIX (Cont'd)

TEST 01 FAULT CODE	3 0	3 1	3 2	3 3	3 4	3 5	3 6	3 7	3 8	4 1	4 4	4 7	4 8
<b>OPER. CORRECTIVE ACTION</b>													
Test Successful													
Clean Hub Pads													
Thread Tape Correctly													
Clean Head/Tape Path/Hubs	A	A					A				A		A
Change Tape							B				B		B
Close Door													
<b>FAILING ASSEMBLY</b>													
Servo-Control	1	1	1	2	1	2	1	1	1	1	1	1	1
Read Amplifier							13				8		
Write Driver							11				6		
Formatter Read							9				4		
Formatter Write							10				5		
Interface													
Power Supply													
Power Driver	8	8	3				8	2			3		
Control Panel													
Compressor	2	2	5				2						
Filter	6	6	4				6						
Supply Air Bearing	3	3					3						
Take-Up Air Bearing	4	4					4						
Head (Amplitude Error)													
Head (Data Reliability)							12				7		
Write Cable							14				9		
Supply Motor/Tach								3					3
Supply Hub													
Take-Up Motor/Tach	7	7	2	1		1	7				2		2
EOT/BOT Sensor													
Door Interlock Switch													
File Protect Sensor													
Pressure Regulator	5	5	6				5						
Cooling Fan													
Temperature Sensor													
Further isolation action.													
Run Test 02 (See NOTE 1)	X	X					X						
Run Test 03 (See NOTE 1)			X	X		X							X

NOTE 1. Run tests 02 and 03 only if test 01 directs their use to further identify the probable failing assembly. For termination code/failing assembly matrix, refer to tables 6-4 thru 6-19.



Table 6-3. FAULT CODE MATRIX (Cont'd)

TEST 01 FAULT CODE	5 0	5 1	5 2	5 3	5 4	5 5	5 6	5 9	6 0	6 1	6 2	6 3	6 4
OPER. CORRECTIVE ACTION													
Test Successful													
Clean Hub Pads			A										
Thread Tape Correctly													
Clean Head/Tape Path/Hubs													
Change Tape													
Close Door													
See NOTE 2									X	X			
FAILING ASSEMBLY													
Servo-Control	1	1	1	1	3	1	2		2	2			
Read Amplifier					2								
Write Driver					1								
Formatter Read												1	1
Formatter Write							1				1	2	2
Interface							3	1					
Power Supply													
Power Driver													
Control Panel									1	1			
Compressor													
Filter													
Supply Air Bearing													
Take-Up Air Bearing													
Head (Amplitude Error)													
Head (Data Reliability)					4								
Write Cable					5								
Supply Motor/Tach			3										
Supply Hub			4										
Take-Up Motor/Tach			2										
EOT/BOT Sensor													
Door Interlock Switch													
File Protect Sensor													
Pressure Regulator													
Cooling Fan													
Temperature Sensor													
Run Test 02 (See NOTE 1)													
Run Test 03 (See NOTE 1)			X										

NOTE 1. Run tests 02 and 03 only if test 01 directs their use to further identify the probable failing assembly. For termination code/failing assembly matrix, refer to tables 6-4 thru 6-19.

NOTE 2. Fault can be caused by the operator pressing any operator panel switches for longer than 15 seconds during the power-up cycle.

Table 6-3. FAULT CODE MATRIX (Cont'd)

TEST 01 FAULT CODE	6 5	6 6	6 7	6 8	6 9
OPER. CORRECTIVE ACTION					
Test Successful					
Clean Hub Pads					
Thread Tape Correctly					
Clean Head/Tape Path/Hubs					
Change Tape					
Close Door					
See NOTE 2					
FAILING ASSEMBLY					
Servo-Control					1
Read Amplifier					
Write Driver					
Formatter Read	1				
Formatter Write		2			2
Interface		1	1	1	3
Power Supply					
Power Driver					
Control Panel					
Compressor					
Filter					
Supply Air Bearing					
Take-Up Air Bearing					
Head (Amplitude Error)					
Head (Data Reliability)					
Write Cable					
Supply Motor/Tach					
Supply Hub					
Take-Up Motor/Tach					
EOT/BOT Sensor					
Door Interlock Switch					
File Protect Sensor					
Pressure Regulator					
Cooling Fan					
Temperature Sensor					
Run Test 02 (See NOTE 1)					
Run Test 03 (See NOTE 1)					

NOTE 1. Run tests 02 and 03 only if test 01 directs their use to further identify the probable failing assembly. For termination code/failing assembly matrix, refer to tables 6-4 thru 6-19.

NOTE 2. Fault can be caused by the operator pressing any operator panel switches for longer than 15 seconds during the power-up cycle.

This page left blank intentionally.

### Test 02 Follow-Up

If test 01 ends in fault code 22, run test 02 to further specify the probable failing assembly. Refer to table 6-4 for the termination code/probable failing assembly matrix.

Table 6-4. TEST 02 TERMINATION CODES FOLLOWING TEST 01 FAULT CODE 22

TERMINATION CODE	7 0	7 1	8 4	9 2	OTHER CODES
OPERATOR ACTION					
Illegal Op Sequence	A				
Ensure Tape is Thd'd		A			
Repeat Test		B			
FAILING ASSEMBLY					
Servo-Control		1	1	2	3
Power Driver					4
Supply Motor/Tach				1	
Supply Hub					1
Take-Up Motor/Tach			2		2
Run test 03 (see table 6-11)					X

If test 01 ends in fault code 24, run test 02 to further specify the probable failing assembly. Refer to table 6-5 for the termination code/probable failing assembly matrix.

Table 6-5. TEST 02 TERMINATION CODES FOLLOWING TEST 01 FAULT CODE 24

TERMINATION CODE	7 0	7 1	7 3	7 4	8 2	9 2	9 8	OTHER CODES
OPERATOR ACTION								
Illegal Op Sequence	A							
Ensure Tape is Thd'd		A						
Repeat Test		B						
FAILING ASSEMBLY								
Servo-Control		1	3	1		3	3	1
Power Driver			2	2	1	2	2	2
Supply Motor/Tach			1			1	1	

If test 01 ends in fault code 26, run test 02 to further specify the probable failing assembly. Refer to table 6-6 for the termination code/probable failing assembly matrix.

Table 6-6. TEST 02 TERMINATION CODES FOLLOWING TEST 01 FAULT CODE 26, AND TEST 03

TERMINATION CODE	7 0	7 1	8 1	8 2	8 4	OTHER CODES
OPERATOR ACTION						
Illegal Op Sequence	A					
Ensure Tape is Thd'd		A				
Repeat Test		B				
FAILING ASSEMBLY						
Servo-Control			3	3		1
Power Driver			1	1		
Supply Motor/Tach			2	2		
Take-Up Motor/Tach					1	
Door Interlock Sw			4	4	2	

If test 01 ends in fault codes 30 or 31, run test 02 to further specify the probable failing assembly. Refer to table 6-7 for the termination code/probable failing assembly matrix.

Table 6-7. TEST 02 TERMINATION CODES FOLLOWING TEST 01 FAULT CODES 30 or 31

TERMINATION CODE	7 0	7 1	7 2	7 3	7 4	7 5	8 4	8 9	9 0	9 1	9 2	OTHER CODES
OPERATOR ACTION												
Illegal Op Sequence	A											
Ensure Tape is Thd'd		A										
Repeat Test		B										
FAILING ASSEMBLY												
Servo-Control		1		2		2	2			3		2
Power Driver												3
Compressor			3	4	3	4				2	2	
Filter			2		2						1	
Supply Air Bearing					1	1		1				
Take-Up Air Bearing			1	1					1			
Take-Up Motor/Tach							1					1
Pressure Regulator			4	3	4	3				1	3	
Run test 03 (see table 6-14)												X

If test 01 ends in fault code 36, run test 02 to further specify the probable failing assembly. Refer to table 6-8 for the termination code/probable failing assembly matrix.

Table 6-8. TEST 02 TERMINATION CODES FOLLOWING TEST 01 FAULT CODE 36

TERMINATION CODE	7 0	7 1	7 2	7 3	7 4	7 5	8 4	8 9	9 0	9 1	9 2	OTHER CODES
OPERATOR ACTION												
Illegal Op Sequence	A											
Ensure Tape is Thd'd		A										
Repeat Test		B										
FAILING ASSEMBLY												
Servo-Control		1		2		2	2			3		2
Power Driver												3
Compressor			3	4	3	4				2	2	
Filter			2		2						1	
Supply Air Bearing					1	1		1				
Take-Up Air Bearing			1	1					1			
Take-Up Motor/Tach							1					1
Pressure Regulator			4	3	4	3				1	3	
Formatter Read												4
Formatter Write												5
Write Driver												6
Read/Write Head												7
Read Amplifier												8
Write Cable												9
Run test 03 (see Table 6-17)												X

This page left blank intentionally.

### Test 03 Follow-Up

If test 01 ends in fault code 03, run test 03 to further specify the probable failing assembly. Refer to table 6-9 for the termination code/probable failing assembly matrix.

Table 6-9. TEST 03 TERMINATION CODES FOLLOWING TEST 01 FAULT CODE 03

TERMINATION CODE	8 2	8 4	9 4	9 5	9 6	9 8	0 0	OTHER CODES
OPERATOR ACTION								
Ensure Tape is Not Threaded			A					
Repeat Test				A			A	
FAILING ASSEMBLY								
Read Amp							3	6
Power Driver	1							
Magnetic Head							2	5
Servo/Control		2			2	1	4	3
Formatter Read							5	1
Formatter Write							6	2
Take-Up Motor/Tach		1			1	2		
Write Cable							7	7
Write Driver							1	4

If test 01 ends in fault code 04 or 06, run test 03 to further specify the probable failing assembly. Refer to table 6-10 for the termination code/probable failing assembly matrix.

Table 6-10. TEST 03 TERMINATION CODES FOLLOWING TEST 01 FAULT CODE 04 or 06

TERMINATION CODE	8 2	8 4	9 4	9 5	9 6	9 8	OTHER CODES
OPERATOR ACTION							
Ensure Tape is Not Threaded			A				
Repeat Test			B	A			
FAILING ASSEMBLY							
Servo/Control		2			2	1	3
Power Driver	1						1
Read/Write Head							5
Take-Up Motor/Tach		1			1	2	
Write Driver							4
Read Amplifier							6
Formatter Read							1
Formatter Write							2
Write Cable							7



If test 01 ends in fault code 22, run test 03 after test 02 to further specify the probable failing assembly. Refer to table 6-11 for the termination code/probable failing assembly matrix.

Table 6-11. TEST 03 TERMINATION CODES FOLLOWING TEST 01 FAULT CODE 22

TERMINATION CODE	9 4	9 5	9 6	9 8	OTHER CODES
OPERATOR ACTION					
Ensure Tape is Not Threaded	A				
Repeat Test		A			
FAILING ASSEMBLY					
Take-Up Motor/Tach			1	1	
Servo-Control			2	2	1
Power Driver					2

If test 01 ends in fault code 25, run test 03 to further specify the probable failing assembly. Refer to table 6-12 for the termination code/probable failing assembly matrix.

Table 6-12. TEST 03 TERMINATION CODES FOLLOWING TEST 01 FAULT CODE 25

TERMINATION CODE	9 4	9 5	9 8	OTHER CODES
OPERATOR ACTION				
Ensure Tape is Not Threaded	A			
Repeat Test	B	A		
FAILING ASSEMBLY				
Servo-Control	1	1	2	2
Power Driver				3
Take-Up Motor/Tach			1	
Supply Hub				1

If test 01 ends in fault code 26, run test 03 subfault code 09, to further specify the probable failing assembly. Refer to table 6-13 for the termination code/probable failing assembly matrix.

Table 6-13. TEST 03 TERMINATION CODES FOLLOWING TEST 01 FAULT CODE 26

TERMINATION CODE	8 2	8 4	9 4	9 5	9 6	0 0	OTHER CODES
OPERATOR ACTION							
Ensure Tape is Not Threaded			A				
Repeat Test				A			
FAILING ASSEMBLY							
Take-Up Motor/Tach	2	1			1	3	3
Power Driver	1				2	1	
Servo/Control	3	2			4	2	1
Door Interlock Switch					3	4	
Supply Motor/Tach						5	2
Run Test 02						X	

If test 01 ends in fault code 30 or 31, run test 03 after test 02 to further specify the probable failing assembly. Refer to table 6-14 for the termination code/probable failing assembly matrix.

Table 6-14. TEST 03 TERMINATION CODES FOLLOWING TEST 01 FAULT CODE 30 or 31

TERMINATION CODE	8 2	8 4	9 4	9 5	9 6	9 8	0 0	OTHER CODES
OPERATOR ACTION								
Ensure Tape is Not Threaded			A					
Repeat Test			B	A				
FAILING ASSEMBLY								
Servo/Control	2	2	1	1	2		3	3
Power Driver	1						1	1
Take-Up Motor/Tach		1			1	1	2	2

If test 01 ends in fault code 32, run test 03 to further specify the probable failing assembly. Refer to table 6-15 for the termination code/probable failing assembly matrix.

Table 6-15. TEST 03 TERMINATION CODES FOLLOWING TEST 01 FAULT CODE 32

TERMINATION CODE	8 2	8 4	9 4	9 5	9 6	9 8	OTHER CODES
OPERATOR ACTION							
Ensure Tape is Not Threaded			A				
Repeat Test			B	A			
FAILING ASSEMBLY							
Servo-Control			1	1	2	2	1
Power Driver	1						2
Take-Up Motor/Tach		1			1	1	3
Compressor							5
Filter							4
Pressure Regulator							6

If test 01 ends in fault code 33 or 35, run test 03 to further specify the probable failing assembly. Refer to table 6-16 for the termination code/probable failing assembly matrix.

Table 6-16. TEST 03 TERMINATION CODES FOLLOWING TEST 01 FAULT CODE 33 or 35

TERMINATION CODE	9 4	9 5	9 8	OTHER CODES
OPERATOR ACTION				
Ensure Tape is Not Threaded	A			
Repeat Test	B	A		
FAILING ASSEMBLY				
Servo-Control	1	1		1
Take-Up Motor/Tach			1	

If test 01 ends in fault code 36, run test 03 after test 02 to further specify the probable failing assembly. Refer to table 6-17 for the termination code/probable failing assembly matrix.

Table 6-17. TEST 03 TERMINATION CODES FOLLOWING TEST 01 FAULT CODE 36

TERMINATION CODE	8 2	8 4	9 4	9 5	9 6	9 8	OTHER CODES
OPERATOR ACTION							
Ensure Tape is Not Threaded			A				
Repeat Test			B	A			
FAILING ASSEMBLY							
Servo-Control		2			2	1	3
Take-Up Motor/Tach		1			1	2	
Power Driver	1						
Formatter Read							1
Formatter Write							2
Write Driver							4
Read/Write Head							5
Read Amplifier							6
Write Cable							7

If test 01 ends in fault code 48, run test 03 to further specify the probable failing assembly. Refer to table 6-18 for the termination code/probable failing assembly matrix.

Table 6-18. TEST 03 TERMINATION CODES FOLLOWING TEST 01 FAULT CODE 48

FAULT CODE	9 4	9 5	9 6	9 8	OTHER CODES
OPERATOR ACTION					
Ensure Tape is Not Threaded	A				
Repeat Test	B	A			
FAILING ASSEMBLY					
Servo-Control	1	1	2		1
Take-Up Motor/Tach			1	1	
Supply Motor/Tach					2

If test 01 ends in fault code 52, run test 03 to further specify the probable failing assembly. Refer to table 6-19 for the termination code/probable failing assembly matrix.

Table 6-19. TEST 03 TERMINATION CODES FOLLOWING TEST 01 FAULT CODE 52

TERMINATION CODE	9 4	9 5	9 6	9 8	0 0	OTHER CODES
OPERATOR ACTION						
Ensure Tape is Not Threaded	A					
Repeat Test	B	A			A	
FAILING ASSEMBLY						
Servo-Control	1	1	2			1
Take-Up Motor/Tach			1	1		
Supply Motor/Tach						2
Supply Hub						3

## ON-SITE PROCEDURES

Prior to initiating any diagnostic test, make a thorough visual inspection of the STU. Inspection of the head recording surface, cleaner blades, write enable reflective ring, hub assemblies, and proper seating of electrical connectors is always the first step in an organized troubleshooting procedure.

After you have made a visual inspection, perform a functional check of the STU as follows (see figure 6-1):

1. Perform SAM 1001 if STU will not power on properly. This procedure checks out the functional operation of the transport, including ancillary sensors, which the microprocessor cannot fault-detect without manual operation and visual feedback.
2. Run operator diagnostic test 01 to verify the fault.
3. Refer to specific SAM fault code.
4. Perform any corrective action as directed by the SAM.
5. Verify operation of the transport by again performing operator diagnostic test 01 or other verification tests, as directed by the SAM.

### Diagnostic Tests

The maintenance philosophy for trouble analysis of the STU is to minimize the time required to restore the STU to an on-line status, after a reported fault condition occurs. This is accomplished by providing two types of diagnostics:

1. An operator test which is initiated before reporting the fault condition to the CE.
2. Customer engineer tests to be performed when you report to the site for corrective action.

### Operator Diagnostics

The operator diagnostic is a functional test which directs operator actions after a fault code appears. The operator test, procedure, and a fault code/corrective action table are contained in Volume I, 49762900. The fault code may indicate any one or more of the following types of fault conditions:

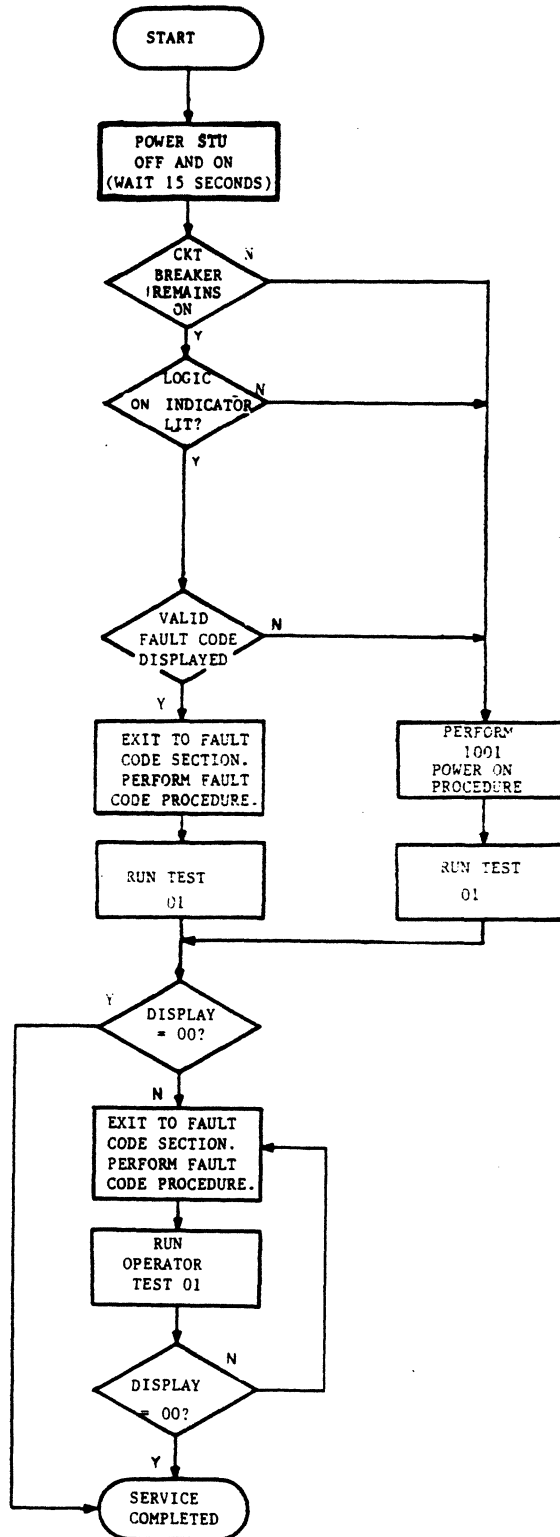

Figure 6-1. Flowchart of On-Site Trouble Analysis

o Environment or Media Problems

This type of problem requires that the operator clean the tape path area and/or use another known good quality tape.

o Operator Error Problem

This type of problem is caused by conditions such as door open, write enable ring not present, or tape threaded incorrectly.

o Transport Circuit Problems

These are fault conditions which require service by a customer engineer.

It is your responsibility to ensure that the operator performs test 01, and to determine from the operator the fault code which appears after running the operator diagnostic.

Because the operator diagnostic is an integral part of the trouble analysis procedures, subsequent paragraphs contain the procedure to initiate this diagnostic. The only difference between the procedure contained in the Operation Section of Volume I, and the following procedure, is an expanded feature to display a sub-fault code for maintenance purposes.

#### Diagnostic Test Procedure

The operator diagnostic consists of one test which runs for approximately 13 minutes, when a 2400 foot tape is used. Tests 02 and 03 are available, but should be performed by the operator, only at your request. Faults encountered during the test terminate the diagnostics and display a numerical code on the display panel. Any fault code should be logged by the operator and reported to you, if operator corrective actions do not resolve the problem. The operator diagnostic is initiated as follows:



o Transport Status

1. Transport powered on (LOGIC ON indicator lit).
2. Tape threaded through tape path and onto take-up reel, but not loaded (untensioned).

o Test Procedure

1. Press TEST switch.
  - a. DIAGNOSTIC indicator lights.
  - b. Display panel indicates 01.
2. Press EXECUTE switch.
  - a. Test starts with display panel incrementing from 00, 11, 22 thru 99. Verify that all segments of the numerical display are functioning.
  - b. Concurrent with step a. above, the following indicators light: FILE PROTECT, LOGIC ON, ON-LINE, RESET and DIAGNOSTICS.
  - c. Test continues with various motion and read/write exercises for approximately 13 minutes.

The transport performs a REWIND/UNLOAD operation and 00 is indicated on the display panel if the test runs to completion. If the test is unsuccessful, the test terminates and a fault code appears on the display panel. If the problem cannot be resolved through operator actions, as indicated in table 6-3, the fault code is referenced directly to the corresponding SAM table for corrective action.

When the SAM tables are referenced for corrective action, a sub-fault code interrogation may be required. With the fault code still indicated on the display panel, press and hold the CE switch. This action will cause the sub-fault code to appear on the display.

If a SAM action item indicates test 02 or 03 to be performed, select test as follows:

#### NOTE

Tests 02 and 03 should not be used unless test 01 directs their use. Test 02 and test 03 may fail if run without first running test 01, and fault code 70 or 71 will appear.

1. Press RESET switch (resets fault code from test 01, if still displayed).
2. Press TEST switch (01 is indicated on display).
3. Press STEP switch one time (numerical display steps from 01 to 02). If test 03 is required, press STEP a second time to increment display from 02 to 03.
4. Press EXECUTE switch (test starts).

Tests 02 and 03 are very short tension and servo tests. Display 00 is indicated if test is successful. If test is not successful, refer the fault code to the original SAM table.

#### Customer Engineer Diagnostics

Perform the customer engineer diagnostics in conjunction with the requirements of the structured analysis method (SAM) Tables. When reporting to the site, obtain as much information from the operator and operating system as you can. Fault codes, the frequency at which they occur and, if possible, the operation in progress at that time, are all things which should be considered prior to execution of the diagnostics. If the fault is intermittent, the information received from the operator and operating system may be instrumental in directing you to the appropriate test to duplicate the condition under which the fault occurs.

If the fault condition is a hard error, or one which occurs frequently, start the troubleshooting procedure by executing operator diagnostic test 01. This test is a lead-in to all fault codes and subsequent SAM tables.

Initiate customer engineer tests as follows:

o Transport Status

Status requirements of the transport are listed in the individual SAM troubleshooting tables.

o Test Procedure

1. While pressing CE switch, press TEST switch.
  - a. DIAGNOSTICS indicator lights.
  - b. Display panel indicates 00.
2. Press STEP switch.
  - a. Display number increments each time STEP is pressed, or increments automatically if STEP is held pressed.
  - b. To facilitate test number selection, use the following procedure. Example: Test 39 selection required.
    - Press STEP switch until 03 appears on display panel.
    - Press TEST switch and the 3 digit transfers to the left.
    - Display now indicates 30.
    - Press STEP switch again until display increments from 30 to 39.
  - c. If test options (see test description subsection) are desired, press and hold CE switch, then press EXEC while CE is held pressed. Display will indicate 00. STEP switch is then pressed to select the desired option.
3. Press EXECUTE switch.
  - a. Test is initiated.

If test runs to completion, the display panel indicates 00. If test fails, the display panel indicates the fault code.

## Customer Engineer Special Load/Unload Procedures

While performing specific fault code procedures, you may be directed to perform a TEST LOAD or an UNTENSIONED UNLOAD procedure. A description of these special procedures follows.

### o TEST LOAD

Follow this procedure if a reel of tape is suspected of not being wrapped properly and a tape re-wrap is necessary.

1. Press TEST switch. DIAGNOSTIC indicator lights and display indicates 01.
2. Press LOAD switch. Forward tape motion is initiated to EOT. The take-up reel motor moves tape while the supply reel motor is completely untensioned. When EOT is detected, a normal rewind function is initiated (with tape tension) to BOT.

### o UNTENSIONED UNLOAD

Use this procedure to unwrap tape from the take-up reel onto the supply reel following a servo fault. The velocity servo (take-up reel motor) is completely untensioned while the supply reel moves tape in the reverse direction. Press UNLOAD switch while tape is untensioned (not loaded).

## Sub-Fault Codes

The SAM tables may direct you to display the sub-fault code associated with the primary fault code. The sub-fault code is displayed by pressing the CE switch after the primary fault code appears on the digital indicators. The sub-fault code is displayed as long as the CE switch is held pressed.

## STRUCTURED ANALYSIS METHOD (SAM) TABLES

After a fault code appears on the display panel, refer the fault code number directly to the corresponding number of the SAM which are listed numerically on subsequent pages. The basic SAM format (figure 6-2) uses YES (Y) or NO (N) responses to sequential conditions to lead the customer engineer to appropriate corrective action.

When a fault can be caused by any one of several factors, the separate actions to correct each of these factors are numbered according to priority level with the action, having the highest probability of success, being listed as number 1. If several actions have the same probability of correcting the fault, the one that is easiest to perform (takes the least time) is listed as the first action.

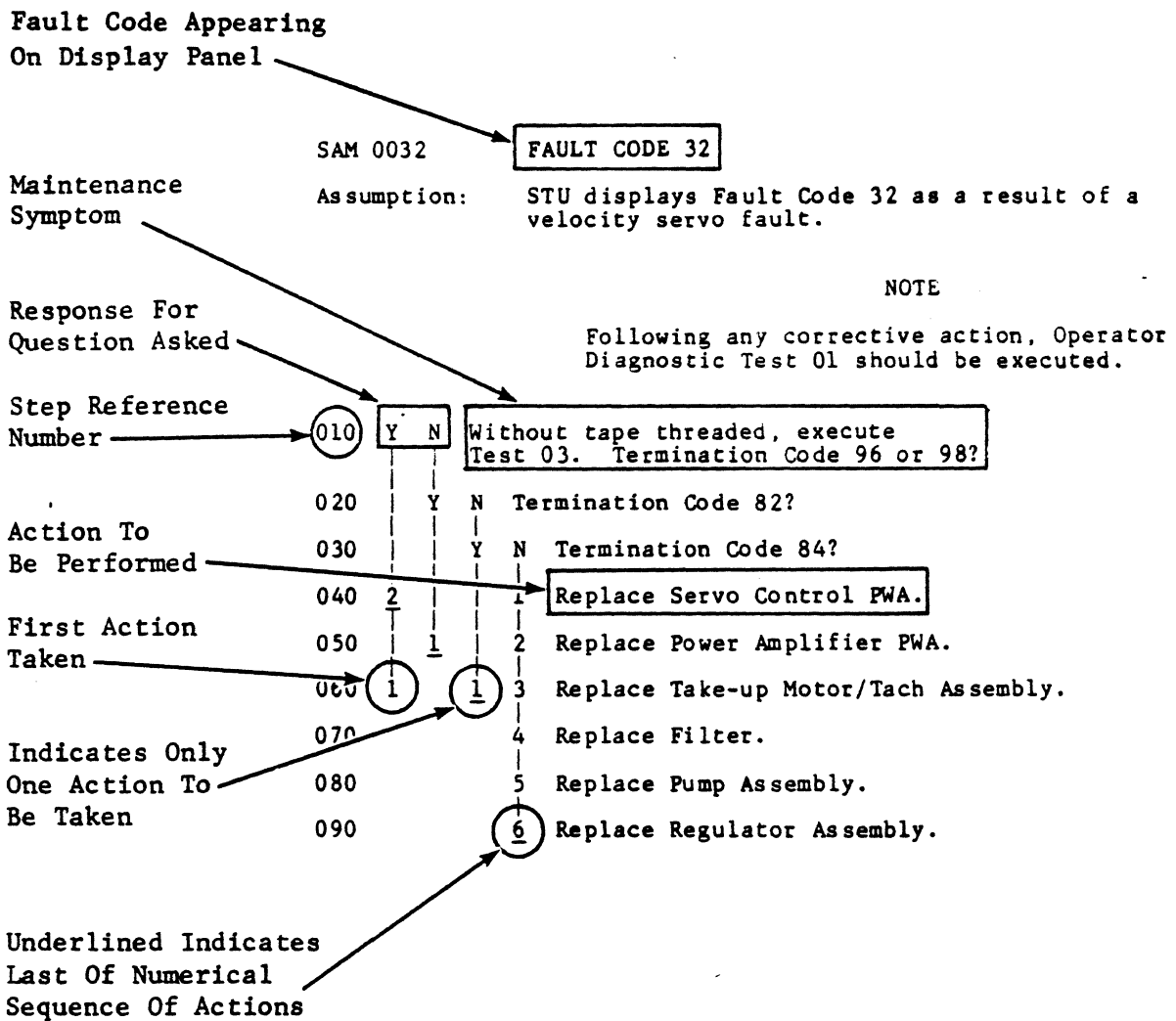

Figure 6-2. Example of Structured Analysis Method (SAM) Table

## SUB-FAULT CODE INTREPRETATION

The sub-fault code is displayed by pressing the CE switch after the primary fault code is indicated. Sub-fault codes are listed after the associated fault code.

Interpretation of the sub-fault numerical display is as follows:

1. Example 1 - Fault Code 25, Sub-Fault Code 64 (Figure 6-3)

- a. 40 - Take Up sensor saw fault code first.
- b. 20 - Fault code occurred on up ramp.
- c. 04 - Fault occurred in reverse direction.
- d. 00 - Fault occurred with low speed demanded.
- e. 00 - Fault occurred in start/stop mode.

64

### FAULT CODE 25 SUB-FAULT CODE

a.	00	File sensor saw the fault first
	40	Takeup sensor saw the fault first
<hr/>		
b.	00	Fault occurred during constant motion
	10	Fault occurred on down ramp
	20	Fault occurred on up ramp
	30	Fault occurred in stoplock
<hr/>		
c.	00	Fault occurred in forward direction
	04	Fault occurred in reverse direction
<hr/>		
d.	00	Fault occurred with 25 ips demanded
	01	Fault occurred with 100 ips demanded
	02	Fault occurred with 200 ips demanded
<hr/>		
e.	00	Fault occurred while drive was moving at constant velocity, on ramp, or in stoplock for less than 1 sec.
	01	Fault occurred with drive in stoplock for more than 1 sec.

Figure 6-3. Sub-Fault Code Interpretation - Example 1

2. Example 2 - Fault Code 25, Sub-Fault Code 19 (Figure 6-4)

- a. 00 - File sensor saw fault first.
- b. 10 - Fault occurred on down ramp.
- c. 00 - Fault occurred in forward direction.
- d. 01 - Fault occurred with low speed demanded.
- e. 08 - Fault occurred in streaming mode.

19

FAULT CODE 25 SUB-FAULT CODE

a.	00	File sensor saw the fault first
	40	Takeup sensor saw the fault first
b.	00	Fault occurred during constant motion
	10	Fault occurred on down ramp
	20	Fault occurred on up ramp
	30	Fault occurred in stoplock
c.	00	Fault occurred in forward direction
	04	Fault occurred in reverse direction
d.	00	Fault occurred with 25 ips demanded
	01	Fault occurred with 100 ips demanded
	02	Fault occurred with 200 ips demanded
e.	00	Fault occurred with pneumatic pump enabled.
	08	Fault occurred with pneumatic pump shut down.

Figure 6-4. Sub-Fault Code Interpretation - Example 2

TROUBLESHOOTING DIAGRAMS

NOTE

Functional Troubleshooting Procedure 1001 through 1003 check out the functional operation of the STU, including ancilliary sensors, which the STU microprocessors cannot fault detect without manual operation and visual feedback.

<u>SAM CHECKOUT</u>	<u>DESCRIPTION</u>
1001	Power-on 1 Checkout
1002	Power-on 2 Checkout
1003	Power-on 3 Checkout

---

<u>SAM FAULT CODE</u>	<u>DESCRIPTION</u>
01	Read envelope fault
02	Read amplitude tolerance fault
03	ID fault
04	Low speed write errors
05	Low speed read errors
06	High speed write errors
07	High speed read errors
08	Noise in IBG
09	Hardware failure
10	Operator door open
11	Absence of tape
12	Load fault
13	Tape threaded incorrectly
14	BOT location fault
15	Load/Unload aborted by operator
16	Diagnostic tape is write protected
17	Ran off end of tape
18	Tape already loaded
19	Reserved for future use
20	File tension sensor fault
21	Take-up tension sensor fault
22	Unable to tension tape
23	Unable to re-establish tension
24	High tension fault
25	Low tension fault
26	Servo fault
27	No coarse tachs
28	Reserved for future use
29	Absence of tape



**SAM  
FAULT  
CODE**

**DESCRIPTION**

30	Up ramp fault
31	Down ramp fault
32	Stoplock over-run
33	Tape positioning fault
34	BOT positioning fault
35	Positioning fault
36	Speed fault
37	Compressor power-up
38	Illegal load sequence
39	
40	
41	Stack overflow fault
42	
43	
44	Unrecoverable write error
45	
46	
47	Velocity correction fault
48	Unload fault
49	
50	Irrecoverable device health check fault
51	Recoverable device health check fault
52	Speed calculation fault
53	Arithmetic error
54	Erase/Write current fault
55	Unload/Rewind Timeout fault
56	Processor communication fault
57	
58	
59	Interface Adapter Fault (SCSI) Interface Only
60	Irrecoverable operator panel fault
61	Recoverable operator panel fault
62	Formatter write board health check
63	Formatter read/write interface health check
64	Formatter read PWA health check fault in data loopback
65	Formatter read PWA health check fault
66	Formatter/Adapter interface health check
67	Interface PWA health check fault
68	Interface PWA checksum fault
69	Remote diagnostics fault

POWER-ON CHECKOUT 1001

This power-on/installation SAM is for the isolation of ac power faults.

Assumption: The STU ac circuit breaker is turned off and the STU is plugged into a live ac supply of the correct voltage.

NOTE

Following any corrective action, reconnect any assemblies that may have been disconnected and restart this SAM with circuit breaker turned off.

010	Y	N	Turn circuit breaker ON. Does circuit breaker remain on?
020		Y	N Disconnect cooling fan cable from power supply. Turn circuit breaker ON. Does circuit breaker remain on?
030		Y	N Reconnect cooling fan cable to power supply. Disconnect pump cable from power supply. Turn circuit breaker ON. Does circuit breaker remain on?
040			<u>1</u> Replace power supply assembly.
050			<u>1</u> Replace pump assembly.
060			<u>1</u> Replace cooling fan assembly.
070	Y	N	Is the LOGIC ON indicator on operator panel lit?
080		Y	N Is the LOGIC OFF indicator on operator panel lit?
090		Y	N Is the cooling fan operating?
100			<u>1</u> Ensure that ac supply cable is plugged into power supply cable.
110			<u>2</u> Ensure that ac supplied to the STU is live and the correct voltage for the unit.
	2	2	2
	A	B	C
			D

POWER-ON CHECKOUT 1001

	A	B	C	D	
	1	1	1	1	
120					<u>3</u> Replace power supply assembly.
130			1		Ensure operator panel cable is plugged into servo control PWA and power supply.
140			2		Replace power supply assembly.
150			<u>3</u>		Replace operator panel assembly.
160		Y	N		Is the cooling fan operating?
170			<u>1</u>		Replace power supply assembly.
180		<u>1</u>			Go to SAM 1002.
190	Y	N			Is the cooling fan operating?
200			1		Replace cooling fan assembly.
210			<u>2</u>		Replace power supply assembly.
220	Y	N			Is the LOGIC OFF indicator lit?
230		Y	N		Is the 2-digit display blank and FILE PROT indicator lit and RESET, ON-LINE, and DIAGNOSTICS indicators all unlit?
240			Y	N	Are RESET, ON-LINE, and DIAGNOSTICS indicators all lit?
250				Y N	Is the display blank?
260				Y N	Wait for 15 seconds. Is RESET indicator unlit?
270				Y N	Is valid fault code displayed?
280				<u>1</u>	<u>1</u> Replace servo-control PWA. (Refer to set-up tests in servo-control PWA removal/replacement procedure.)
	3	3	3	3	
	A	B	C	D	E

POWER-ON CHECKOUT 1001

	2 A	2 B	2 C	2 D	2 E	
290					1	Go to SAM for displayed fault code.
300				Y	N	Is FILE PROTECT indicator lit?
310	1				1	Replace operator panel assembly.
320			1	1	2	Replace servo-control PWA. (Refer to set-up tests in servo-control PWA removal/replacement procedure.)
330	2		2			Replace power supply assembly
340		1				Go to SAM 1003.

NOTE

If the power-on, auto load option is enabled and tape is not threaded, an error code may occur.

POWER-ON CHECKOUT 1002

This power-on SAM is for the isolation of dc power faults.

Assumption: The STU ac circuit breaker is turned on, the OFF indicator is lit and the cooling fan is operating.

NOTE

Following any corrective action, reconnect any assemblies that may have been disconnected and restart this SAM.

010	Y	N	Disconnect dc cable harnesses from the underside of power supply. Press LOGIC ON switch of operator panel. Does LOGIC ON indicator light and stay lit?				
020		1	Replace power supply assembly.				
030	Y	N	Reconnect dc cable harnesses to power supply. Disconnect dc supply cable from power driver PWA. Press LOGIC ON switch. Does LOGIC ON indicator light and stay lit?				
040		Y	N	Reconnect dc supply cable to power driver PWA. Disconnect dc supply cable from write driver PWA. Press LOGIC ON switch. Does LOGIC ON indicator light and stay lit?			
050			Y	N	Reconnect dc supply cable to write driver PWA. Disconnect dc supply cable from servo-control PWA and read amplifier PWA. Press LOGIC ON switch. Does LOGIC ON indicator light and stay lit?		
060				Y	N	Reconnect dc supply cable to servo-control PWA and read amplifier PWA. Disconnect dc supply cable from formatter write PWA and formatter read PWA. Press LOGIC ON switch. Does LOGIC ON indicator light and stay lit?	
070					Y	N	Reconnect dc supply cable to formatter read PWA. Disconnect dc supply cable from interface PWA. Press LOGIC ON switch. Does LOGIC ON indicator light and stay lit.
	2	2	2	2	2	2	
	A	B	C	D	E	F	

POWER-ON CHECKOUT 1002

	A	B	C	D	E	F	
	1	1	1	1	1	1	
080						1	Replace power supply assembly.
090					2	2	Replace operator panel assembly.
100					1		Replace interface PWA.
110				Y	N		Remove formatter write PWA and reconnect dc supply cable to formatter read PWA. Press LOGIC ON switch. Does LOGIC ON indicator light and stay lit?
120					1		Replace formatter read PWA.
130				2	2		Replace power supply assembly.
140				1			Replace formatter write PWA.
150			Y	N			Remove servo-control PWA and reconnect dc supply cable to read amplifier PWA. Press LOGIC ON switch. Does LOGIC ON indicator light and stay lit?
160				1			Replace read amplifier PWA (Run set-up test 31).
170	2	2	2	2			Replace power supply assembly.
180			1				Replace servo-control PWA. (Refer to set-up tests in servo-control PWA removal/replacement procedure)
190		1					Replace write driver PWA (Run set-up tests 64, 31).
200	1						Replace power driver PWA.

POWER-ON CHECKOUT 1003

This SAM is for the detection/isolation of operational faults.

Assumption: The STU is powered on with the LOGIC OFF indicator unlit, the LOGIC ON indicator lit, the FILE PROTECT indicator lit, and the unit unloaded.

NOTE

Following any corrective action, this SAM should be restarted.

010	Y	N	Thread a write enabled tape and close operator door. Press TEST switch. Does DIAGNOSTICS indicator light?
020		1	Replace operator panel assembly.
030		<u>2</u>	Replace servo-control PWA. (Refer to set-up tests in servo-control PWA removal/replacement procedure).
040	Y	N	Is 01 displayed?
050		1	Replace operator panel assembly.
060		<u>2</u>	Replace servo-control PWA. (Refer to set-up tests in servo-control PWA removal/replacement procedure).
070	Y	N	Press EXECUTE switch and observe indicators and display of operator panel. Does display sequence from 00 to 11 to 22 to 99 without any missing segments? And while display is sequencing, are ON-LINE, HI DENSITY, and RESET indicators lit?
080		1	Replace operator panel assembly.
090		<u>2</u>	Replace servo-control PWA. (Refer to set-up tests in servo-control PWA removal/replacement procedure).
100	Y	N	Does operator diagnostic test 01 terminate displaying 00?
110		<u>1</u>	Go to the SAM for the displayed fault code.
120	Y	N	Is the BOT indicator unlit?
		2	
	A	B	

POWER-ON CHECKOUT 1003

A	B	
1	1	
130	1	Replace servo-control PWA. (Refer to set-up tests in servo-control PWA removal/replacement procedure.)
140	<u>2</u>	Replace operator panel assembly.
150	Y N	Press the RESET switch. Is the display blank?
160	1	Replace operator panel assembly.
170	<u>2</u>	Replace servo-control PWA. (Refer to set-up tests in servo-control PWA removal/replacement procedure.)
180	Y N	Thread tape and close operator door. Press LOAD switch. Does STU load tape?
190	Y N	Fault code displayed?
200	1	Replace operator panel assembly.
210	<u>2</u>	Replace servo-control PWA. (Refer to set-up tests in servo-control PWA removal/replacement procedure)
220	<u>1</u>	Go to the SAM for displayed fault code.
230	Y N	Is BOT indicator lit?
240	1	Replace operator panel assembly.
250	<u>2</u>	Replace servo-control PWA. (Refer to set-up tests in servo-control PWA removal/replacement procedure.)
260	Y N	Is FILE PROTECT indicator unlit?
270	1	Replace operator panel assembly
280	<u>2</u>	Replace servo-control PWA. (Refer to set-up tests in servo-control PWA removal/replacement procedure.)
290	Y N	Press ON-LINE switch. Does ON-LINE indicator light?
3	3	
A	B	



POWER-ON CHECKOUT 1003

A	B
2	2
300	1 Replace operator panel assembly.
310	<u>2</u> Replace servo-control PWA. (Refer to set-up tests in servo-control PWA removal/replacement procedure.)
320	Y N Press RESET switch followed by UNLOAD switch. Does STU unload tape?
330	Y N Fault code displayed?
340	1 Replace operator panel assembly.
350	<u>2</u> Replace servo-control PWA. (Refer to set-up tests in servo-control PWA removal/replacement procedure.)
360	<u>1</u> Go to the SAM for the displayed fault code.
370	Y N While pressing CE switch, press TEST switch. Is 00 displayed?
380	1 Replace operator panel assembly.
390	<u>2</u> Replace servo-control PWA. (Refer to set-up tests in servo-control PWA removal/replacement procedure.)
400	Y N Press STEP switch. Is 01 displayed?
410	1 Replace operator panel assembly.
420	<u>2</u> Replace servo-control PWA. (Refer to set-up tests in servo-control PWA removal/replacement procedure.)
430	Y N Press RESET switch. Remove write enable ring from reel and rethread tape. With operator door open, press LOAD switch. Is fault code 10 displayed?
440	1 Replace door switch assembly.
450	<u>2</u> Replace servo-control PWA. (Refer to set-up tests in servo-control PWA removal/replacement procedure.)
4	
A	

POWER-ON CHECKOUT 1003

- 3  
A
- 460 Y N Press RESET switch and close operator door. Press  
LOAD switch. Does the STU load tape successfully?
- 470 | 1 Go to the SAM for the displayed fault.
- 480 Y N Is FILE PROTECT indicator lit?
- 490 | 1 Replace file protect sensor assembly.
- 500 | 2 Replace servo-control PWA. (Refer to set-up tests in  
servo-control PWA removal/replacement procedure.)
- 510 | 3 Replace supply hub assembly.
- 520 | 1 Unload tape; the SAM is completed without finding any  
faults.

NOTE

Use SAM 1001 thru SAM 1003 to check out the functional operation of the STU, including ancilliary sensors, which the STU microprocessors cannot fault detect without manual operation and visual feedback.

FAULT CODE 01 - READ ENVELOPE

Assumption: STU displays fault code 01 as a result of failing to detect a read signal during a read amplitude checking diagnostic test.

The most probable cause of this fault is a dirty read-write head. Another possible cause is damaged tape.

NOTE

Following any corrective action, execute operator diagnostic test 01.

- |     |     |  |
|-----|-----|--|
| 010 | 1   | Clean read-write head, tape cleaner, hub pads and air bearings.  |
| 020 | 2   | Change tape to a known good write-enabled tape.  |
| 030 | 3   | Ensure that cables between read-write head and read amplifier and write driver PWAs are correctly connected. |
| 040 | Y N | Execute CE test 58. Termination code 00?   |
| 050 | 1   | Replace formatter write PWA.   |
| 060 | 2   | Replace servo-control PWA. (Refer to set-up tests in servo-control PWA removal/replacement procedure.)       |
| 070 | Y N | Execute CE test 59. Termination code 00?   |
| 080 | 1 3 | Replace read-write head. (Run set up tests 64, 31.)  |
| 090 | 2 1 | Replace write driver PWA (Run set-up tests 64, 31).  |
| 100 | 3 2 | Replace read amplifier PWA (Run set-up test 31).   |
| 110 | 4 4 | Replace servo-control PWA. (Refer to set-up tests in servo-control PWA removal/replacement procedure.)       |
| 120 | 5   | Replace write cable.   |

FAULT CODE 01

SUB-FAULT CODES, FAULT CODE 01

00 Envelope not detected during read amplitude check  
(EGC test)

---

FAULT CODE 02 - READ AMPLITUDE TOLERANCE

Assumption: STU displays fault code 02 as a result of detecting a read amplitude out of range during a read amplitude checking diagnostic test.

The most probable cause of this fault is a dirty read-write head. Another possible cause is damaged tape.

NOTE

Following any corrective action, execute operator diagnostic test 01.

- |     |   |  |
|-----|---|--|
| 010 | 1 | Clean read-write head, tape cleaner, hub pads and air bearings.  |
| 020 | 2 | Change tape to a known good write-enabled tape.  |
| 030 | 3 | Ensure that cables between read-write head and read amplifier and write driver PWAs are correctly connected. |
| 040 | Y | N Execute CE test 59.<br>Termination code 00?  |
| 050 | 1 | Replace read/write head. (Run set-up tests 64, 31.)  |
| 060 | 2 | 1 Replace write driver PWA (Run set-up tests 64, 31).  |
| 070 | 3 | 2 Replace read amplifier PWA (Run set-up test 31).   |
| 080 | 4 | 4 Replace servo-control PWA. (Refer to set-up tests in servo-control PWA removal/replacement procedure.)     |
| 090 | 5 | 5 Replace formatter write PWA.   |
| 100 | 3 | Replace read-write head. (Run set-up tests 64, 31.)  |
| 110 | 6 | Replace write cable.   |

FAULT CODE 02

SUB-FAULT CODES, FAULT CODE 02

00 Read amplitude outside range 1.5 volts  $\pm$  0.8 volts  
(i.e. difference between EGC gain and gain in backup  
memory would cause an amplitude difference  
greater than 0.8 volts)

---

FAULT CODE 03 - ID FAULT

Assumption: STU displays fault code 03 during an operator diagnostic test due to a failure to read or write the identification burst at load point.

The probable cause of this fault is damaged tape. The tape should be free of defects within the first ten inches of tape after the BOT reflective marker.

NOTE

Following any corrective action, execute operator diagnostic test 01.

- |     |          |          |  |
|-----|----------|----------|--|
| 010 | 1        |          | Clean read-write head, tape cleaner, hub pads and air bearings.  |
| 020 | <u>2</u> |          | Change tape to a known good write-enabled tape.  |
| 030 | Y        | N        | Without tape threaded, run diagnostic test 03. Termination code 00?                                    |
| 040 |          | Y        | N Termination code 98?   |
| 050 |          | <u>1</u> | Go to step 040 of SAM 0004.  |
| 060 |          | 1        | Replace servo-control PWA. (Refer to set-up tests in servo-control PWA removal/replacement procedure.) |
| 070 |          | <u>2</u> | Replace take-up motor/tach assembly. (Run set-up tests 37, 48)   |
| 080 | Y        | N        | Unload tape, execute CE test 59. Termination 00?   |
| 090 | 1        | 2        | Replace write driver PWA. (Run set-up tests 64, 31.)   |
| 100 | 2        | 3        | Replace read-write head. (Run set-up tests 64, 31.)  |
| 110 | 3        | 1        | Replace read amplifier PWA (Run set-up test 31).   |
| 120 | <u>4</u> | 4        | Replace servo-control PWA. (Refer to set-up tests in servo-control PWA removal/replacement procedure.) |
| 130 |          | 5        | Replace formatter read PWA.  |
|     |          | 2        |  |
|     |          | A        |  |

FAULT CODE 03

	A	
	1	
140	6	Replace formatter write PWA.
150	7	Replace write cable.

SUB-FAULT CODES, FAULT CODE 03

00	Unable to read or write PE Identification Burst
01	Unable to read or write GCR ID, ARA Burst, or ARA ID
02	AGC fault occurred while reading or writing from BOT in GCR

---



FAULT CODE 04 - LOW SPEED WRITE ERROR

Assumption: STU displays fault code 04 during an operator diagnostic test due to a failure to write a block within five attempts at low speed, or due to too many write errors while writing to EOT at low speed.

The probable causes of this fault are dirty head and damaged tape.

NOTE

Following any corrective action, execute operator diagnostic test 01.

010	1								Clean read-write head, tape cleaner and air bearings.
020	2								Change tape to a known good write enabled tape.
030	Y	N							Without tape threaded, execute diagnostic test 03. Termination code 98?
040		Y	N						Termination code 96?
050			Y	N					Termination code 82?
060				Y	N				Termination code 84?
070					Y	N			Execute CE test 60. Termination code any other than 00?
080						Y	N		Execute test 58. Termination code any other than 00?
090							Y	N	Execute CE test 59. Termination code 00?
110							3	1	Replace read amplifier PWA. (Run set-up test 31.)
120							2	3	Replace read-write head. (Run set-up tests 64, 31.)
								4	Replace servo/control PWA. (Refer to set-up tests in servo- control PWA removal/replacement procedure.)
	2	2	2	2	2	2	2	2	
	A	B	C	D	E	F	G	H	

FAULT CODE 04

	A	B	C	D	E	F	G	H	
	1	1	1	1	1	1	1	1	
130							1	2	Replace write driver PWA. (Run set-up tests 64, 31.)
140								5	Replace write cable.
150					1		4		Replace formatter read PWA.
160					2	2			Replace formatter write PWA.
170	1	2		2		1			Replace servo-control PWA. (Refer to set-up tests in servo-control PWA removal/replacement procedure.)
180	2	1		1					Replace take-up motor/tach assembly. (Run set-up tests 37, 48)
190			1						Replace power driver PWA.

SUB-FAULT CODES, FAULT CODE 04

---

- 00 Unable to write a block in PE within 5 attempts
  - 01 Unable to write a block in GCR within 5 attempts
  - 37 Filemark detection error
  - 38 More than 32 write error recoveries performed while  
writing to EOT
-

FAULT CODE 05 - LOW SPEED READ ERROR

Assumption: STU displays fault code 05 during a diagnostic test due to a failure to read a block at low speed, or a data error was detected during a data loopback at low speed.

The probable causes of this fault are dirty head and damaged tape.

NOTE

Following any corrective action,  
execute operator diagnostic test 01.

- 010 1 Clean read-write head, tape cleaner and air bearings.
- 020 2 Change tape to a known good write-enabled tape.
- 030 3 Replace read amplifier PWA (Run set-up test 31).
- 040 4 Replace formatter read PWA.
- 050 5 Replace write driver PWA (Run set-up tests 64, 31).
- 060 6 Replace servo-control PWA. (Refer to set-up tests in servo-control PWA removal/replacement procedure.)
- 070 7 Replace formatter write PWA.
- 080 8 Replace read-write head. (Run set-up tests 64, 31.)
- 090 9 Replace write cable.
- 100 10 Replace take-up motor/tach assembly. (Run set-up tests 37, 48)

SUB-FAULT CODES, FAULT CODE 05

- 00 Data error detected while reading in PE  
(No error recovery performed)
- 01 Data error detected while reading in GCR  
(No error recovery performed)
- 37 Filemark detection error

FAULT CODE 06 - HIGH SPEED WRITE ERROR

Assumption: STU displays fault code 06 during operator diagnostic test 01 due to a failure to write a block within 5 attempts at high speed, or due to too many write errors while writing to EOT at high speed.

The probable causes of this fault are dirty head and damaged tape.

NOTE

Following any corrective action, execute operator diagnostic test 01.

010	1							Clean read-write head, tape cleaner, hub pads and air bearings.
020	2							Change tape to a known good write enabled tape.
030	Y	N						Without tape threaded, execute diagnostic test 03. Termination code 98?
040		Y	N					Termination code 96?
050			Y	N				Termination code 82?
060				Y	N			Termination code 84?
070					Y	N		Execute CE test 60. Termination code any other than 00?
080						Y	N	Execute CE test 58. Termination code any other than 00?
090							Y	N Execute CE test 59. Termination code 00?
110							3	1 Replace read amplifier PWA. (Run set-up test 31.)
120							2	3 Replace read-write head. (Run set-up tests 64, 31.)
130							4	4 Replace servo/control PWA. (Refer to set-up tests for servo-control PWA removal/replacement procedure.)
	2	2	2	2	2	2	2	
	A	B	C	D	E	F	G	H

FAULT CODE 06

	A	B	C	D	E	F	G	H	
	1	1	1	1	1	1	1	1	
140							1	2	Replace write driver PWA. (Run set-up tests 64, 31.)
150								5	Replace write cable.
160					1		4		Replace formatter read PWA.
170					2	2			Replace formatter write PWA.
180	1	2		2		1			Replace servo-control PWA. (Refer to set-up tests in servo-control PWA removal/replacement procedure.)
190	2	1		1					Replace take-up motor/tach assembly. (Run set-up tests 37, 48)
200			1						Replace power driver PWA.

SUB-FAULT CODES, FAULT CODE 06

- 00 Unable to write a block in PE within 5 attempts
- 01 Unable to write a block in GCR within 5 attempts
- 37 File mark detection error
- 38 More than 32 write error recoveries performed while  
writing to EOT

FAULT CODE 07 - HIGH SPEED READ ERROR

Assumption: STU displays fault code 07 during operator diagnostic test 01 due to a failure to read a block at high speed, or a data error was detected during a loopback at high speed.

The probable causes of this fault are dirty head and damaged tape.

NOTE

Following any corrective action, execute operator diagnostic test 01.

- 010 1 Clean read-write head, tape cleaner, hub pads and air bearings.
- 020 2 Change tape to a known good write-enabled tape.
- 030 3 Replace read amplifier PWA (Run set-up test 31).
- 040 4 Replace formatter read PWA.
- 050 5 Replace write driver PWA (Run set-up tests 64, 31).
- 060 6 Replace servo-control PWA. (Refer to set-up tests in servo-control PWA removal/replacement procedure.)
- 070 7 Replace formatter write PWA.
- 080 8 Replace read-write head. (Run set-up tests 64, 31.)

SUB-FAULT CODES, FAULT CODE 07

- 00 Data error detected while reading in PE  
(No error recovery performed)
- 01 Data error detected while reading in GCR  
(No error recovery performed)
- 37 File mark detection error

FAULT CODE 08 - NOISE IN IBG

Assumption: STU displays fault code 08 during a diagnostic test due to the detection of noise during an erase operation. An erase operation is used by the error recovery while writing.

The probable causes of this fault are dirty head and damaged tape.

NOTE

Following any corrective action, execute operator diagnostic test 01.

010	1			Clean read-write head, tape cleaner, hub pads and air bearings.
020	2			Change tape to a known good write-enabled tape.
030	Y	N		Execute CE test 60. Termination code other than 00?
040		Y	N	Execute CE test 58. Termination code other than 00?
050			Y	N Unload tape and execute CE test 59. Termination code 00?
060			3	1 Replace read amplifier PWA (Run set-up test 31).
070			5	3 Replace read-write head (Run set-up test 64, 31.)
080			1	2 Replace write driver PWA. (Run set-up tests 64, 31.)
090			4	Replace write cable.
100	1		4	Replace formatter read PWA.
110	2	2		Replace formatter write PWA.
120	1	1	2	Replace servo-control PWA. (Refer to set-up tests in servo-control PWA removal/replacement procedure.)

SUB-FAULT CODES, FAULT CODE 08

00 Noise detected while erasing

FAULT CODE 09 - HARDWARE FAILURE

Assumption: STU displays fault code 09 as a result of unit hardware failure.

NOTE

Following any corrective action, execute operator diagnostic test 01.

- |     |          |   |          |   |
|-----|----------|---|----------|---|
| 010 | Y        | N |          | Press CE switch. Sub-fault code 01?   |
| 020 |          | Y | N        | Sub-fault code 02?  |
| 030 |          |   | Y        | N Sub-fault code 03?  |
| 040 | <u>1</u> |   | <u>2</u> | 1 Replace formatter write PWA.  |
| 050 |          |   | 1        | <u>2</u> Replace servo-control PWA. (Refer to set-up tests in servo-control PWA removal/replacement procedure.) |
| 060 | <u>1</u> |   |          | Replace formatter read PWA.   |

SUB-FAULT CODES, FAULT CODE 09

- |    |   |
|----|---|
| 00 | A hardware failure occurred while executing a read/write diagnostic |
| 01 | Formatter write PWA hardware failure                                |
| 02 | Formatter read PWA hardware failure                                 |
| 03 | Servo-Control PWA hardware failure                                  |
| 04 | Servo-Control PWA hardware interrupt fault                          |



FAULT CODE 10 - OPERATOR DOOR OPEN

Assumption: STU displays fault code 10 as a result of detecting an open operator door condition.

The most probable cause of this fault is the operator door being open. During any normal operation, including execution of diagnostic tests, the door must be closed.

NOTE

Following any corrective action, close the door and execute operator diagnostic test 01.

- |     |          |          |   |
|-----|----------|----------|---|
| 010 | 1        |          | Ensure that all interlock switch leads are unbroken and are firmly connected to the door switch assembly.   |
| 020 | 2        |          | Ensure that all cables are firmly connected to the servo-control PWA.   |
| 030 | Y        | N        | Using a DVM with negative terminal connected to J2 pin 3 of servo-control PWA, measure voltages on outermost terminals of door switch while the operator door is closed. Is voltage difference greater than 0.2 volt? |
| 040 | Y        | N        | Repeat previous operation for innermost terminals. Is voltage difference greater than 0.2 volt?   |
| 050 |          | <u>1</u> | Replace servo-control PWA. (Refer to set-up tests in servo-control PWA removal/replacement procedure)   |
| 060 | 1        | 1        | Ensure door switch plunger on operator door lines up with door switch and will depress switch when door is closed.  |
| 070 | <u>2</u> | <u>2</u> | Replace door switch assembly.   |

FAULT CODE 10

SUB-FAULT CODES, FAULT CODE 10

- 01 Door 1 open on load
  - 02 Door 2 open after tensioning
  - 03 Door opened during unload
  - 04 Door open on untensioned unload
  - 05 Door opened during untensioned unload
  - 06 Door opened during retensioned load unload
  - 07 Door open on diagnostic test
-

FAULT CODE 11 - ABSENCE OF TAPE

Assumption: STU displays fault code 11 as a result of detecting an absence of tape condition during a load operation, or a diagnostic test that requires tape threaded.

The most probable cause of this fault is that tape is not threaded. Another possible cause is that tape is threaded with tape that has oxide removed.

NOTE

Following any corrective action, perform a tape load operation.

- |     |          |          |  |
|-----|----------|----------|--|
| 010 | Y        | N        | Disconnect cable from BOT/EOT sensor assembly. With operator door closed, press LOAD/REWIND switch. Is fault code 11 reported? |
| 020 |          | 1        | Replace BOT/EOT sensor assembly.   |
| 030 | <u>1</u> | <u>2</u> | Replace servo-control PWA. (Refer to set-up tests in servo-control PWA removal/replacement procedure.)                         |

SUB-FAULT CODES, FAULT CODE 11

- |    |                           |
|----|---------------------------|
| 01 | Absence of tape on load   |
| 02 | Absence of tape on test 2 |

FAULT CODE 12 - LOAD FAULT

Assumption: The STU displays fault code 12 as a result of detecting a hub unlatched condition or a tension fault during load operation.

The probable cause of this fault is not latching the supply reel hub after mounting a reel of tape.

A possible cause is that tape being loaded has been subjected to extreme temperature or humidity changes. These tapes can sometimes be recognized by shaking the full reel and hearing tape pack move relative to reel. Also, while loading tape, it will be seen that hub and reel rotate counterclockwise while pack of tape rotate clockwise. To continue using these tapes, rewrap the reel at correct tension. This is achieved by performing a TEST LOAD operation, which wraps all tape onto take-up reel, and then returns tape, correctly tensioned, to the supply reel.

Other possible causes of fault code 12 are:

1. Loading a tape while in tape trailer.
2. Loading a tape with a mispositioned or missing BOT marker. The BOT marker should be positioned 16 feet  $\pm$  2 feet from physical end of tape.
3. Loading a tape with EOT/BOT sensor cable disconnected.

NOTE

Following any corrective action, a tape load operation should be performed.

010	1		Remove supply reel from supply hub and clean hub pads.
020	Y	N	Inspect hub latching mechanism for breakage or excessive wear. Any problem found?
030		Y	N
			Remount reel and latch hub. While holding hub, can reel be easily rotated in either direction?
	2	2	2
	A	B	C

FAULT CODE 22

	A	B	C	D	E		
	1	1	1	1	1		
070				<u>1</u>		Invalid operator sequence. Refer to diagnostic test procedures.	
080				Y	N	Termination code 84?	
090				Y	N	Termination code 92?	
100				Y	N	Execute diagnostic test 03 without tape threaded. Termination code 96 or 98?	
110			<u>1</u>	1	<u>2</u>	<u>2</u>	1 Replace servo-control PWA. (Refer to set-up tests in servo-control PWA removal/replacement procedure.)
120						<u>2</u>	2 Replace power driver PWA.
130					1		1 Replace supply motor/tach assembly.
140				<u>2</u>	1		1 Replace take-up motor/tach assembly. (Run set-up tests 37, 48)
150	<u>1</u>	<u>1</u>					1 Replace supply hub assembly.

SUB-FAULT CODES, FAULT CODE 22

- 
- 01 Unable to successfully maintain tension during load (Fault is reported after tape is unloaded off EOT).
  - 02 Unable to successfully maintain tension during load (Fault is reported with tape still in the tape path after failing to find AOT within 30 seconds)
  - 03 Tape slipping on file reel while accelerating during tension recovery
  - 04 Tape slipping on file reel while decelerating during tension recovery
  - 05 Tape slipping on file reel while decelerating during tension recovery/test load
-

### FAULT CODE 23 - UNABLE TO RE-ESTABLISH TENSION

Assumption: STU displays fault code 23 as a result of being unable to re-establish tape tension during a tape load operation.

The most probable cause of this fault is that the tape being loaded has been subjected to extreme temperature or humidity changes. These tapes can sometimes be recognized by shaking the full reel and hearing the tape pack move relative to the reel. To continue using these tapes, the reel must be re-wrapped at the correct tension. At the time of reporting the fault, all the tape may have been removed from the supply reel. Recovery for this case will be to re-wrap the tape onto the file reel (to the BOT side of the EOT label) and perform a normal load operation. If tape was not removed from the supply reel, a TEST LOAD operation should be performed to remove tape.

#### NOTE

Perform a tape load operation following any corrective action. During load operation, observe the supply reel for pack slip.

- |     |   |  |
|-----|---|--|
| 010 | 1 | Rewind tape onto file reel and repeat load operation.  |
| 020 | 2 | Mount a new reel of tape and retry load operation.   |
| 030 | 3 | Ensure that BOT/EOT sensor assembly cable is firmly connected.   |
| 040 | 4 | Replace servo-control PWA. (Refer to set-up tests in servo-control PWA removal/replacement procedure.) |
| 050 | 5 | Replace supply motor/tach assembly.  |

#### SUB-FAULT CODES, FAULT CODE 23

- |    |  |
|----|--|
| 01 | Unable to establish tension during test load                         |
| 02 | Unable to maintain tension after stopping tape following a test load |
| 03 | Unable to re-establish tension after hub latched test                |

FAULT CODE 24 - HIGH TENSION

Assumption: STU displays fault code 24 as a result of a high tension detected on both air bearings.

NOTE

Following any corrective action, execute operator diagnostic test 01.

- |     |          |          |   |
|-----|----------|----------|---|
| 010 | Y        | N        | Execute diagnostic test 02 with tape threaded. Termination code 70?   |
| 020 | <u>1</u> |          | Invalid operator sequence. Refer to diagnostic test procedures.   |
| 030 | Y        | N        | Termination code 82?  |
| 040 |          | Y        | N Termination code 73 or 74 or 92 or 98?  |
| 050 |          | <u>3</u> | <u>1</u> Replace servo-control PWA. (Refer to set-up tests in servo-control PWA removal/replacement procedure.) |
| 060 | <u>1</u> | <u>2</u> | <u>2</u> Replace power driver PWA.  |
| 070 |          | <u>1</u> | Replace supply motor/tach assembly.   |

SUB-FAULT CODES, FAULT CODE 24 - GROUP 1

- 00 Fault occurred during constant velocity motion
- 10 Fault occurred on down ramp
- 20 Fault occurred on up ramp
- 30 Fault occurred in stoplock

SUB-FAULT CODES, FAULT CODE 24 - GROUP 2

- 00 Fault occurred in forward direction
- 04 Fault occurred in reverse direction

SUB-FAULT CODES, FAULT CODE 24 - GROUP 3

- 00 Fault occurred with low speed demanded
- 01 Fault occurred with high speed demanded
- 02 Fault occurred with rewind speed demanded

FAULT CODE 24

SUB-FAULT CODES, FAULT CODE 24 - GROUP 4

- 00 Fault occurred while drive was moving at constant velocity, on ramp, or in stoplock for less than 1 sec.
- 01 Fault occurred with drive in stoplock for more than 1 sec.

SUB-FAULT CODES, FAULT CODE 24 - GROUP 5

- 00 Fault occurred with pneumatic pump enabled
- 08 Fault occurred with pneumatic pump shut down



FAULT CODE 25 - LOW TENSION

Assumption: STU displays fault code 25 as a result of a low tension condition being detected on one of the air bearings.

The most probable cause of this fault is damaged tape. Should tape be torn, then the fault can occur as tape passes over air bearing. Another cause, is that tape sticks to read-write head.

NOTE

Following any corrective action, execute operator diagnostic test 01.

- |     |   |   |   |  |
|-----|---|---|---|--|
| 010 | 1 |   |   | Clean read-write head, tape cleaner, hub pads and air bearings.  |
| 020 | 2 |   |   | Change tape to a known good, write enabled scratch tape.   |
| 030 | 3 |   |   | Unload tape by pressing UNLOAD switch while tape is not at BOT. Remove reel and clean hub pads.          |
| 040 | Y | N |   | Inspect hub latching mechanism for breakage or excessive wear. Any problem found?                        |
| 050 |   | Y | N | Remount reel and latch hub. While holding hub, can reel be rotated in either direction?                  |
| 060 |   | Y | N | Execute diagnostic test 03 without tape threaded. Termination code 98?                                   |
| 070 |   |   | 1 | Replace power driver PWA.  |
| 080 |   |   | 2 | 2 Replace servo-control PWA. (Refer to set-up tests in servo-control PWA removal/replacement procedure.) |
| 090 |   |   | 1 | Replace take-up motor/tach assembly. (Run set-up tests 37, 48)   |
| 100 | 1 | 1 |   | Replace supply hub assembly.   |

FAULT CODE 25

SUB-FAULT CODES, FAULT CODE 25 - GROUP 1

00 Supply sensor saw the fault first  
40 Takeup sensor saw the fault first

SUB-FAULT CODES, FAULT CODE 25 - GROUP 2

00 Fault occurred during constant motion  
10 Fault occurred on down ramp  
20 Fault occurred on up ramp  
30 Fault occurred in stoplock

SUB-FAULT CODES, FAULT CODE 25 - GROUP 3

00 Fault occurred in forward direction  
04 Fault occurred in reverse direction

SUB-FAULT CODES, FAULT CODE 25 - GROUP 4

00 Fault occurred with low speed demanded  
01 Fault occurred with high speed demanded  
02 Fault occurred with rewind speed demanded  
03 Fault occurred with slow speed mode demanded

SUB-FAULT CODES, FAULT CODE 25 - GROUP 5

00 Fault occurred while drive was moving at constant velocity, on ramp, or in stoplock for less than 1 sec.  
01 Fault occurred with drive in stoplock for more than 1 sec.

SUB-FAULT CODES, FAULT CODE 25 - GROUP 6

00 Fault occurred with pneumatic pump enabled  
08 Fault occurred with pneumatic pump shut down

FAULT CODE 26 - SERVO FAULT

Assumption: STU displays fault code 26 as a result of a servo fault.

NOTE

Following any corrective action for sub-fault codes 01 to 06, thread tape onto take-up reel, wind on by hand for approximately 50 turns, and then perform UNTENSIONED UNLOAD procedure. For all other sub-fault codes, load and then unload tape.

- 010 1 Ensure all cables to power driver PWA are correctly connected.
- 020 2 Ensure all leads to top cover switch are unbroken and correctly connected.
- 030 Y N Without tape threaded, execute diagnostic test 03. Termination code 82?
- 040 1 Replace power driver
- 050 2 Replace take-up motor/tach assembly. (Run set-up tests 37, 48.)
- 060 3 Replace servo-control PWA. (Refer to set-up tests in servo-control PWA removal/replacement procedure)
- 070 Y N Termination code 84?
- 080 1 Replace take-up motor/tach assembly. (Run set-up tests 37, 48.)
- 090 2 Replace servo-control PWA. (Refer to set-up tests in servo-control PWA removal/replacement procedure.)

2  
A

FAULT CODE 26

	A			
	1			
100	Y	N		Termination code 96?
110	Y	N		Termination code 00?
120		Y	N	Does take-up reel move during execution of test 03?
130	<u>1</u>		1	Ensure cable is correctly connected to take-up tach.
140			1	Replace take-up motor/tach assembly. (Run set-up tests 37, 48)
150			<u>2</u>	2 Replace servo-control PWA. (Refer to set-up tests in servo-control PWA removal/replacement procedure.)
160			<u>3</u>	3 Replace door interlock switch.
170	Y	N		With tape threaded, execute diagnostic test 02. Termination code 70?
180	<u>1</u>			Invalid operator sequence. Refer to diagnostic test procedures.
	3		3	
	A		B	

FAULT CODE 26

	A	B	
	2	2	
190		Y	N Termination code 81?
200			Y N Termination code 82?
			Y N Termination code 84?
210		<u>3</u>	<u>3</u> <u>1</u> Replace servo-control PWA. (Refer to set-up tests in servo-control PWA removal/replacement procedure.)
220			2 <u>1</u> Replace take-up motor/tach assembly. (Run set-up tests 37, 48.)
230		1	1 Replace power driver assembly.
240		2	2 Replace supply motor/tach assembly.
250	Y	N	Does take-up reel move during execution of test 03?
260		1	1 Replace door interlock switch.
270	1	2	2 Replace take-up motor/tach assembly. (Run set-up tests 37, 48.)
280		<u>3</u>	3 Replace servo-control PWA. (Refer to set-up tests in servo-control PWA removal/replacement procedure.)
290	<u>2</u>		2 Replace power driver PWA.

SUB-FAULT CODES, FAULT CODE 26

---

- 01 Takeup reel moving in wrong direction during untensioned unload
  - 02 Takeup reel not moving during untensioned unload
  - 03 Takeup reel too fast during untensioned unload
  - 04 Takeup reel too slow during untensioned unload
  - 05 Voltage sensed in wrong half of file reel amplifier bridge while pulsing supply reel
  - 06 Timeout to get unwind speed during untensioned unload
  - 07 Voltage sense fault in supply reel amplifier bridge during load
  - 08 Voltage sense fault in takeup reel amplifier bridge during load
  - 09 Fine line tach fault on load
-

FAULT CODE 27 - NO COARSE TACHS

Assumption: STU displays fault code 27 as a result of not detecting any single line tachs from supply reel.

NOTE

Following any corrective action,  
execute operator diagnostic test 01.

- 010 1 Ensure that cable is correctly connected to supply motor/tach.
- 020 2 Replace servo-control PWA. (Refer to set-up tests in servo-control PWA removal/replacement procedure.)
- 030 3 Replace supply motor/tach assembly.

SUB-FAULT CODES, FAULT CODE 27

- 01 No coarse tachs during load
- 02 No coarse tachs during tension recovery section of load
- 03 Two coarse tachs not detected within 4 seconds during file reel radius calculation
- 04 File reel radius calculation out of range during load

This page left blank intentionally.

FAULT CODE 29 - ABSENCE OF TAPE

Assumption: STU displays fault code 29 as a result of detecting absence of tape. This fault can be caused by the use of a damaged tape that has oxide missing, such that the BOT and EOT sensors detect light passing through the tape.

Unloading of tape with a short leader may also result in fault code 29.

NOTE

Following any corrective action, execute operator diagnostic test 01.

- |     |   |   |  |
|-----|---|---|--|
| 010 | Y | N | Disconnect cable from the EOT/BOT sensor assembly. Remove the reel of tape, close operator door, and press the LOAD switch. Fault code 11? |
| 020 | 2 | 1 | Replace servo-control PWA assembly. (Refer to set-up tests in servo-control PWA removal/replacement procedure.)                            |
| 030 | 1 |   | Replace BOT/EOT sensor assembly.   |

SUB-FAULT CODES, FAULT CODE 29

01 Absence of tape

---



FAULT CODE 30 - UP RAMP

Assumption: STU displays fault code 30 as a result of a detected fault on an up ramp. A possible cause of this fault, with stiction tapes, is when tape sticks to the read-write head.

NOTE

Following any corrective action, execute operator diagnostic test 01.

010	<u>1</u>													Clean read-write head, tape cleaner, hub pads and air bearings.
020	Y	N												With tape threaded, execute diagnostic test 02. Termination code 70?
030	<u>1</u>													Invalid operator sequence. Refer to diagnostic test procedures.
040	Y	N												Termination code 89?
050		Y	N											Termination code 72?
060			Y	N										Termination code 73?
070				Y	N									Termination code 74?
080					Y	N								Termination code 75?
090						Y	N							Termination code 84?
100							Y	N						Termination code 90?
110								Y	N					Termination code 91?
120									Y	N				Termination code 92?
130										Y	N			Without tape threaded, execute diagnostic test 03. Termination code 98?
140											Y	N		Termination code 96?
		2	2	2	2	2	2	2	2	2	2	2	2	
		A	B	C	D	E	F	G	H	I	J	K	L	

FAULT CODE 30

	A	B	C	D	E	F	G	H	I	J	K	L				
	1	1	1	1	1	1	1	1	1	1	1	1	Y	N	Termination code 82?	
150																
160													Y	N	Termination code 84?	
170												1		1	Replace power driver PWA	
180						1				1	1		1	2	Replace take-up motor/tach assembly. (Run set-up tests 37, 48)	
190			2		2	2		3			2	2	2	3	Replace servo-control PWA. (Refer to set-up tests in servo-control PWA removal/replacement procedure.)	
200		2		2					1						1	Replace filter.
210		4	3	4	3			1	3							Replace regulator assembly.
220		3	4	3	4			2	2							Replace compressor assembly.
230	1			1	1											Replace supply air bearing assy.
240		1	1				1									Replace take-up air bearing assy.

SUB-FAULT CODES, FAULT CODE 30 - GROUP 1

- 03 Failed to reach erase head target within deadman time
- 05 Failed to reach end of up ramp within deadman time
- 06 Ramp time less than nominal - 50% (i.e. too fast)
- 07 Ramp time greater than nominal + 50% (i.e. too slow)

FAULT CODE 30

SUB-FAULT CODES, FAULT CODE 30 - GROUP 2

00 Fault occurred on forward ramp  
20 Fault occurred on reverse ramp

SUB-FAULT CODES, FAULT CODE 30 - GROUP 3

00 Fault occurred on 25 ips start/stop ramp  
10 Fault occurred on 12.5 ips start/stop ramp  
40 Fault occurred on 75 ips streaming ramp

FAULT CODE 31 - DOWN RAMP

Assumption: STU displays fault code 31 as a result of a detected fault on a down ramp.

NOTE

Following any corrective action,  
execute operator diagnostic test 01.

010	1													Clean read-write head, tape cleaner hub pads and air bearings.
020	Y	N												With tape threaded, execute diagnostic test 02. Termination code 70?
030	1													Invalid operator sequence. Refer to diagnostic test procedures.
040	Y	N												Termination code 89?
050		Y	N											Termination code 72?
060			Y	N										Termination code 73?
070				Y	N									Termination code 74?
080					Y	N								Termination code 75?
090						Y	N							Termination code 84?
100							Y	N						Termination code 90?
110								Y	N					Termination code 91?
120									Y	N				Termination code 92?
130										Y	N			Without tape threaded, execute diagnostic test 03. Termination code 98?
140											Y	N		Termination code 96?
	2	2	2	2	2	2	2	2	2	2	2	2		
	A	B	C	D	E	F	G	H	I	J	K	L		

FAULT CODE 31

	A	B	C	D	E	F	G	H	I	J	K	L			
150	1	1	1	1	1	1	1	1	1	1	1	1	Y	N	Termination code 82?
160	1	1	1	1	1	1	1	1	1	1	1	1	Y	N	Termination code 84?
170	1	1	1	1	1	1	1	1	1	1	1	1	1	1	Replace power driver PWA.
180	1	1	1	1	1	1	1	1	1	1	1	1	1	2	Replace take-up motor/tach assembly. (Run set-up tests 37, 48)
190	1	1	2	1	2	2	1	3	1	1	2	2	2	3	Replace servo-control PWA. (Refer to set-up tests in servo-control PWA removal/replacement procedure.)
200	1	2	1	2	1	1	1	1	1	1	1	1	1	1	Replace filter.
210	1	4	3	4	3	1	1	1	3	1	1	1	1	1	Replace regulator assembly.
220	1	3	4	3	4	1	1	2	2	1	1	1	1	1	Replace compressor assembly.
230	1	1	1	1	1	1	1	1	1	1	1	1	1	1	Replace supply air bearing assy.
240	1	1	1	1	1	1	1	1	1	1	1	1	1	1	Replace take-up air bearing assy.

SUB-FAULT CODES, FAULT CODE 31 - GROUP 1

- 03 Failed to detect change of direction (forward to reverse) on forward high speed down ramp
- 04 Failed to detect change of direction (reverse to forward) on reverse high speed down ramp
- 05 Failed to reach end of down ramp within deadman time
- 06 Ramp time less than nominal - 50% (i.e. too fast)
- 07 Ramp time greater than nominal + 50% (i.e. too slow)

FAULT CODE 31

SUB-FAULT CODES, FAULT CODE 31 - GROUP 2

00 Fault occurred on forward ramp  
20 Fault occurred on reverse ramp

SUB-FAULT CODES, FAULT CODE 31 - GROUP 3

00 Fault occurred on 25 ips start/stop ramp  
10 Fault occurred on 12.5 ips start/stop ramp  
40 Fault occurred on 75 ips streaming ramp

FAULT CODE 32 - STOPLOCK OVER-RUN

Assumption: STU displays fault code 32 as a result of a velocity servo fault.

NOTE

Following any corrective action, execute operator diagnostic test 01.

010	Y	N		Without tape threaded, execute operator diagnostic Test 03. Termination code 96 or 98?
020		Y	N	Termination code 82?
030			Y	N Termination code 84?
040	<u>2</u>			1 Replace servo-control PWA. (Refer to set-up tests in servo-control PWA removal/replacement procedure.)
050		<u>1</u>		2 Replace power driver PWA.
060	1		<u>1</u>	3 Replace take-up motor/tach assembly. (Run set-up tests 37, 48)
070				4 Replace filter.
080				5 Replace compressor assembly.
090				<u>6</u> Replace regulator assembly.

SUB-FAULT CODES, FAULT CODE 32

---

- 01 Position 32 quarter tachs reverse of correct stoplock position
  - 02 Position 32 quarter tachs forward of correct stoplock position
  - 04 Fault occurred while in gentle dither mode
-

FAULT CODE 33 - TAPE POSITIONING

Assumption: STU displays fault code 33 as a result of a tape positioning fault when about to write.

NOTE

Following any corrective action,  
execute operator diagnostic test 01.

- |     |          |          |  |
|-----|----------|----------|--|
| 010 | Y        | N        | Remove reel of tape and execute operator diagnostic test 03. Termination code 98?                      |
| 020 |          | <u>1</u> | Replace servo-control PWA. (Refer to set-up tests in servo-control PWA removal/replacement procedure.) |
| 030 | <u>1</u> |          | Replace take-up motor/tach assembly. (Run set-up tests 37, 48)   |

SUB-FAULT CODES, FAULT CODE 33

- |    |   |
|----|---|
| 01 | Passed erase head turn-on point when about to write at low speed  |
| 02 | Passed erase head turn-on point when about to write at high speed |



FAULT CODE 34 - BOT POSITIONING

Assumption: STU displays fault code 34 as a result of the STU losing positioning control at load point.

NOTE

Following any corrective action,  
execute operator diagnostic test 01.

010 1 Replace servo-control PWA. (Refer to set-up tests in  
servo-control PWA removal/replacement procedure.)

SUB-FAULT CODES, FAULT CODE 34

- 01 Timed out waiting for BOT in forward direction during a load point reposition.
- 02 Time out waiting for BOT in reverse direction during a load point reposition.

FAULT CODE 35 - POSITIONING FAULT

Assumption: STU displays fault code 35 as a result of the STU losing positioning control.

NOTE

Following any corrective action, execute operator diagnostic test 01.

- |     |   |          |  |
|-----|---|----------|--|
| 010 | Y | N        | Remove reel of tape and execute diagnostic test 03. Termination code 98?                                 |
| 020 |   | <u>1</u> | Replace a servo-control PWA. (Refer to set-up tests in servo-control PWA removal/replacement procedure.) |
| 030 |   | <u>1</u> | Replace take-up motor/tach assembly. (Run set-up tests 37, 48)   |

SUB-FAULT CODES, FAULT CODE 35 - GROUP 1

- |    |                                      |
|----|--------------------------------------|
| 00 | Failed to reach target at low speed  |
| 02 | Failed to reach target at high speed |

SUB-FAULT CODES, FAULT CODE 35 - GROUP 2

- |    |   |
|----|---|
| 00 | Failed to reach target in forward direction |
| 01 | Failed to reach target in reverse direction |

FAULT CODE 36 - SPEED FAULT

Assumption: STU displays fault code 36 as a result of a speed fault.

NOTE

Following any corrective action, execute operator diagnostic test 01.

010	Y	N	With tape threaded, execute diagnostic test 02. Termination code 70?													
020	<u>1</u>	Invalid operator sequence. Refer to diagnostic test procedures.														
030	Y	N	Termination code 89?													
040		Y	N	Termination code 72?												
050			Y	N	Termination code 73?											
060				Y	N	Termination code 74?										
070					Y	N	Termination code 75?									
080						Y	N	Termination code 84?								
090							Y	N	Termination code 90?							
100								Y	N	Termination code 91?						
110									Y	N	Termination code 92?					
120									<u>1</u>	Go to step 010 of fault code 04.						
130									<u>1</u>	Replace take-up motor/tach assy (Run set-up test 37, 48)						
140									<u>2</u>	<u>2</u>	<u>2</u>	<u>3</u>	Replace servo-control PWA. (Refer to set-up tests in servo-control PWA removal/replacement procedure.)			
150										<u>2</u>	<u>2</u>	<u>2</u>	<u>1</u>	Replace filter.		
									A	B	C	D	E	F	G	H

FAULT CODE 36

	A	B	C	D	E	F	G	H	
	1	1	1	1	1	1	1	1	
160									Replace regulator assembly.
		4	3	4	3		1	3	
170		T		T			2	2	Replace compressor assembly.
		3	4	3	4				
180			T		1				Replace supply air bearing assembly.
	1				1				
190		1	1			1			Replace take-up air bearing assembly.

SUB-FAULT CODES, FAULT CODE 36

- 00 Excessive speed when running at low speed
- 04 Speed too slow when running at high speed

FAULT CODE 37 - COMPRESSOR POWER-UP

Assumption: STU displays fault code 37 as a result of not being able to re-establish tension within 5 seconds of pump power-up.

NOTE

Following any corrective action, execute diagnostic test 01.

- 010 1 Replace servo-control PWA. (Refer to set-up tests in servo-control PWA removal/replacement procedure.)
- 020 2 Replace power driver PWA.
- 030 3 Replace supply motor/tach assembly.

SUB-FAULT CODES, FAULT CODE 37

01 Unable to re-establish tension within 5 seconds

FAULT CODE 38 - ILLEGAL LOAD SEQUENCE

Assumption: STU displays fault code 38 if a LOAD sequence is attempted following test 80.

The probable cause of this fault code is pressing the LOAD switch immediately after execution of test 80.

NOTE

Following any corrective action, execute diagnostic test 01.

- 010 1 Power STU OFF, then ON.
- 020 2 Replace servo/control PWA. (Refer to set-up tests in servo-control PWA removal/replacement procedure.)

SUB-FAULT CODES, FAULT CODE 38

00 Illegal LOAD sequence following test 80

FAULT CODE 41 - STACK OVERFLOW

Assumption: STU displays fault code 41 as a result of a servo-control PWA microprocessor stack overflow fault.

NOTE

Following any corrective action, execute operator diagnostic test 01.

010 1 Replace servo-control PWA. (Refer to set-up tests in servo-control PWA removal/replacement procedure.)

SUB-FAULT CODES, FAULT CODE 41

---

01 Hardware stack underflowed  
02 Hardware stack overflowed  
03 User stack underflowed  
04 User stack overflowed

---

FAULT CODE 44 - UNRECOVERABLE WRITE ERROR

Assumption: STU displays fault code 44 as a result of the error recovery procedure becoming exhausted during an on-line WRITE command; or as a result of a fatal error during write error recovery procedure.

The probable causes of this fault are dirty head and damaged tape.

NOTE

Following any corrective action, execute operator diagnostic test 01.

010	1							Clean read-write head, tape cleaner and air bearings.	
020	2							Change tape to a known good write-enabled tape.	
030	Y	N						Without tape threaded, execute diagnostic test 03. Termination code 98?	
040		Y	N					Termination code 96?	
050			Y	N				Termination code 82?	
060				Y	N			Termination code 84?	
070					Y	N		Execute CE test 60. Termination code other than 00?	
080						Y	N	Execute test 58. Termination code other than 00?	
090							Y	N	Execute CE test 59. Termination code 00?
110							3	1	Replace read amplifier PWA. (Run set-up test 31.)
120							2	3	Replace read-write head. (Run set-up tests 64, 31.)
130								4	Replace servo/control PWA. (Refer to set-up tests in servo- control PWA removal/replacement procedure.)
	2	2	2	2	2	2	2	2	
	A	B	C	D	E	F	G	H	



FAULT CODE 44

	A	B	C	D	E	F	G	H	
	1	1	1	1	1	1	1	1	
140							1	2	Replace write driver PWA. (Run set-up tests 64, 31.)
150								<u>5</u>	Replace write cable.
160					1		4		Replace formatter read PWA.
170								<u>5</u>	Replace interface PWA.
180					<u>2</u>	<u>2</u>			Replace formatter write PWA.
190	1	<u>2</u>		<u>2</u>		1			Replace servo-control PWA. (Refer to set-up tests in servo-control PWA removal/replacement procedure.)
200	<u>2</u>	1		1					Replace take-up motor/tach assembly. (Run set-up tests 37, 48)
210			<u>1</u>						Replace power driver PWA.

SUB-FAULT CODES, FAULT CODE 44

---

00 Fatal error, or error recovery procedure exhausted  
during a WRITE command in buffered mode

---

This page intentionally left blank.

FAULT CODE 47 - VELOCITY CORRECTION

Assumption: STU displays fault code 47 resulting from a velocity correction calculation fault.

This fault be caused by the velocity correction factor in the back-up memory being corrupted. Should this be the case, the power-on health check should fault, displaying fault code 51. To overcome this problem, CE test 37 could be executed. However, if all precautions are taken, the back-up memory should never be corrupted.

NOTE

Following any corrective action, execute operator diagnostic test 01.

- 010 1 Replace servo-control PWA. (Refer to set-up tests in servo-control PWA removal/replacement procedure.)

SUB-FAULT CODES, FAULT CODE 47

- 01 Speed correction multiplier in the backup memory is out of range
-

FAULT CODE 48 - UNLOAD FAULT

Assumption: STU displays fault code 48 resulting from an unload fault. This fault can be caused by a damaged tape leader.

NOTE

Following any corrective action, tape should be loaded and unloaded again.

- |     |   |   |   |
|-----|---|---|---|
| 010 | 1 |   | Clear read-write head, tape cleaner, hub pads and air bearings.   |
| 020 | 2 |   | Change tape to a known good tape.   |
| 030 | Y | N | Without tape threaded, execute diagnostic test 03. Termination code 98?                                 |
| 040 |   | Y | N Termination code 96?  |
| 050 |   | 2 | 1 Replace servo-control PWA. (Refer to set-up tests in servo-control PWA removal/replacement procedure) |
| 060 |   |   | 2 Replace supply motor/tach assembly.   |
| 070 | 1 | 1 | Replace take-up motor/tach assembly. (Run set-up tests 37, 48)  |

SUB-FAULT CODES, FAULT CODE 48

- |    |   |
|----|---|
| 01 | Did not find AOT within 6 seconds of losing tension on unload |
|----|---|

FAULT CODE 50 - IRRECOVERABLE DEVICE  
HEALTH CHECK

Assumption: STU displays fault code 50 as a result of a servo-control PWA health check fault.

NOTE

Following any corrective action, the unit should be powered off and on again.

010 1 Replace servo-control PWA. (Refer to set-up tests in servo-control PWA removal/replacement procedure.)

SUB-FAULT CODES, FAULT CODE 50

---

01	Servo-Control diagnostic PROM checksum fault
02	Servo-Control flag memory fault
03	Servo-Control PTM II fault
04	Servo-Control PTM I fault
05	Servo-Control RAM fault
08	Servo-Control functional PROM checksum fault

---

FAULT CODE 51 - RECOVERABLE DEVICE HEALTH CHECK

Assumption: STU displays fault code 51 during power-on health check.

A possible cause of this fault is that the write enable jumper on the servo-control PWA, which protects the contents of the back-up memory, has been left in the STORE position. If this has occurred, re-initialize the back-up memory as described in servo-control PWA verification check in the removal and replacement portion of this section.

NOTE

Following any corrective action, power the unit off and on again.

- 010 1 Replace servo-control PWA. (Refer to set-up tests in servo-control PWA removal/replacement procedure.)

SUB-FAULT CODES, FAULT CODE 51

---

01	2201	EEPROM checksum fault
02	2210	EEPROM checksum fault
12	2210	EEPROM checksum fault
14		DAC fault

---

FAULT CODE 52 - SPEED CALCULATION

Assumption: STU displays fault code 52 as a result of a radius calculation fault.

A possible cause of this fault is that BOT reflective marker is not positioned correctly. ANSI Standard X3.39 specifies that the BOT marker should be placed from 14 feet to 18 feet from the physical beginning of tape.

NOTE

Following any corrective action, execute operator diagnostic test 01.

010	<u>1</u>		Check BOT marker position or try a new tape.
020	Y	N	Without tape threaded, execute diagnostic test 03. Termination code 98?
030		Y	N Termination code 96?
040			<u>1</u> Remove tape reel and clean hub pads.
050		<u>2</u>	<u>2</u> Replace servo-control PWA. (Refer to set-up tests in servo-control PWA removal/replacement procedure)
060			<u>3</u> Replace supply motor/tach assembly.
070			<u>4</u> Replace supply reel hub assembly.
080	<u>1</u>	<u>1</u>	Replace take-up motor/tach assembly. (Run set-up tests 37, 48)

FAULT CODE 52

SUB-FAULT CODES, FAULT CODE 52 - GROUP 1

- 10 A previous fault caused by modulus being too large
- 20 A previous fault caused by modulus change inconsistent with direction of tape
- 40 A previous fault caused by modulus being outside expected range
- 80 Unable to obtain consistent harvest counts in determining the file reel radius

SUB-FAULT CODES, FAULT CODE 52 - GROUP 2

- 01 This fault caused by modulus being too large
- 02 This fault caused by modulus change inconsistent with direction of tape
- 04 This fault caused by modulus being outside expected range
- 08 This fault caused by harvest count greater than 8000



FAULT CODE 53 - ARITHMETIC ERROR

Assumption: STU displays fault code 53 as a result of a radius calculation arithmetic error.

NOTE

Following any corrective action,  
execute operator diagnostic test 01.

010 1 Replace servo-control PWA. (Refer to set-up tests in servo-control PWA removal/replacement procedure.)

SUB-FAULT CODES, FAULT CODE 53

---

- 01 Attempt to divide by 0
  - 02 Integer overflow on floating point to integer conversation
  - 03 Negative result on floating point subtraction
  - 04 Radius calculation during load out of range
-

FAULT CODE 54 - ERASE/WRITE CURRENT

Assumption: STU displays fault code 54 as a result of a write/erase current fault.

NOTE

Following any corrective action, execute operator diagnostic test 01.

- |     |   |   |  |
|-----|---|---|--|
| 010 | Y | N | Sub-fault code 04 or 10?   |
| 020 | 1 | 1 | Replace write driver PWA (Run set-up tests 64, 31).  |
| 030 | 3 | 2 | Replace read amplifier PWA (Run set-up test 31).   |
| 040 | 4 | 3 | Replace servo-control PWA. (Refer to set-up tests in servo-control PWA removal/replacement procedure.) |
| 050 | 2 |   | Replace read-write head. (Run set-up tests 64, 31.)  |
| 060 | 5 |   | Replace write cable.   |

SUB-FAULT CODES, FAULT CODE 54

- |    |  |
|----|--|
| 01 | Erase current present after degauss    |
| 02 | Write current present when degauss     |
| 04 | Write current not present when writing |
| 08 | Write current present when reading     |
| 10 | Erase current not present when writing |
| 20 | Erase current present when reading     |

FAULT CODE 55 - UNLOAD/REWIND TIMEOUT FAULT

Assumption: STU displays fault code 55 as a result of the servo-control microprocessor timing out during a rewind or load/rewind operation.

NOTE

Following any corrective action, execute operator diagnostic test 01.

010 1 Replace servo-control PWA. (Refer to set-up tests in servo-control PWA removal/replacement procedure.)

SUB-FAULT CODES, FAULT CODE 55

01 Failed to reach BOT within specified time during load  
02 Failed to reach BOT within specified time during rewind

FAULT CODE 56 - PROCESSOR COMMUNICATION

Assumption: STU displays fault code 56 as a result of a communication problem between the two STU microprocessors.

NOTE

Following any corrective action, device dc power should be turned off and then turned on, followed by the execution of operator diagnostic test 01.

- |     |   |   |  |
|-----|---|---|--|
| 010 | 1 |   | Ensure that the cable between the formatter write PWA and servo-control PWA is firmly connected.       |
| 020 | 2 | T | Ensure that the DC power connector is firmly connected to the formatter write PWA.                     |
| 030 | Y | N | Controller fault?  |
| 040 | 2 | 1 | Replace formatter write PWA.   |
| 050 | 3 | 2 | Replace servo-control PWA. (Refer to set-up tests in servo-control PWA removal/replacement procedure.) |
| 060 | 1 | 3 | Replace interface PWA.   |

SUB-FAULT CODES, FAULT CODE 56

- 01 MOVE TAG or COMMAND TAG or STATUS/DATA did not get reset
- 02 INTERRUPT or MOVE TAG did not get set
- 03 ACKNOWLEDGE or COMMAND TAG did not get set
- 04 BUSY or STATUS/DATA did not get set
- 05 BUSY or STATUS/DATA did not get reset
- 06 INTERRUPT or MOVE TAG did not get reset
- 07 ACKNOWLEDGE or COMMAND TAG did not get reset
- 08 ACKNOWLEDGE or COMMAND TAG did not get set
- 09 DATA STROBE did not get reset
- 10 DATA STROBE did not get set
- 11 BUS INTEGRITY test fault
- 12 PRIMARY STATUS test fault
- 13 PIA/1 PORT A test fault
- 19 Formatter health check did not complete within 20 msec
- 20 Formatter did not respond to interrupt within 1 second
- 22 Number of bytes transferred exceeded 32 during tests 95 or 99

FAULT CODE 59 - INTEFACE ADAPTER FAULT  
(SCSI Interface Only)

Assumption: STU displays fault code 56 as a result of an interface adapter fault.

NOTE

Following any corrective action, the unit should be powered off and powered on again.

010	Y	N	Press CE switch. Subfault code 00?
020		Y	N Run Test 57. Termination code other than 00?
030		<u>1</u>	Ensure short RAM test switch is closed (* switch 1E/4).
040	2	1	Check all test switches to ensure they are set as follows: * switch 1D/1-6 closed 1D/7-8 open 1E/4-8 closed 9F/2-4 closed 9F/5 open 9H/1-4 open
050	<u>3</u>	<u>2</u>	Replace interface PWA.

NOTE: The individual switch numbers reference the number on the switch pack and NOT the number printed on the PCB.

SUB-FAULT CODES, FAULT CODE 59

00 7 sec. timer expired while waiting for SCSI diagnostics to complete  
01 25 sec. timer expired while waiting for SCSI diagnostics to complete  
91 PROM #1 checksum error  
92 PROM #2 checksum error  
93 PROM #3 checksum error  
94 8085 failed self-test  
95 Processor RAM memory error  
97 Timer error  
98 SCSI chip error  
99 8085 processor failed initial tests  
9B DMA registers failed test  
9D DMA data paths failed tests  
9F 256K data buffer failed tests  
All other codes - SCSI/STU communication fault.



FAULT CODE 60 - IRRECOVERABLE OPERATOR PANEL

Assumption: STU displays fault code 60 as the result of a functional operator panel switch being closed during power-on health check.

This fault can also be generated if any of the LOAD/REWIND, UNLOAD, ON-LINE or RESET switches are pressed for 15 seconds during the power-on health check.

NOTE

Following any corrective action, the STU should be powered off and powered on again.

- 010 1 Check control panel functional switches and repeat power-on health check.
- 020 2 Replace operator panel assembly.
- 030 3 Replace servo-control PWA. (Refer to set-up tests in servo-control PWA removal/replacement procedure.)

SUB-FAULT CODES, FAULT CODE 60

00 LOAD/REWIND or UNLOAD or ONLINE or RESET switch permanently pressed

---

FAULT CODE 61 - RECOVERABLE OPERATOR PANEL

Assumption: STU displays fault code 61 as the result of a diagnostic operator panel switch being closed during power-on health check.

This fault can also be generated if any of the TEST, STEP, CE, or EXECUTE switches are pressed for 15 seconds during the power-on health check. Should this fault occur, normal on-line operation of the STU is available after pressing the RESET switch. However, the use of STU diagnostics will not be made available.

NOTE

Following any corrective action, the STU should be powered off and powered on again.

- 010 1 Check control panel diagnostic switches and repeat power-on health check.
- 020 2 Replace operator panel assembly.
- 030 3 Replace servo-control PWA. (Refer to set-up tests in servo-control PWA removal/replacement procedure.)

SUB-FAULT CODES, FAULT CODE 61

00 TEST or STEP or CE or EXEC switch permanently pressed

---



FAULT CODE 62 - FORMATTER WRITE BOARD  
HEALTH CHECK

Assumption: STU displays fault code 62 as a result of formatter write PWA health check fault.

NOTE

Following any corrective action, the unit should be powered off and powered on again.

010 1 Replace formatter write PWA.

SUB-FAULT CODES, FAULT CODE 62

---

- 00 Power up flip/flop could not be reset
- 01 Write data transfer did not complete within specified time
- 02 Residual byte count check
- 03 CRC generator parity error
- 04 4 to 5 conversion parity error
- 05 AUX CRC generator parity error
  
- 11 ALUZ signal not functional
- 12 ALUZ 2 signal not functional
- 13 ALUN signal not functional
- 14 Arithmetic operation failed
- 15 Logical operation failed
  
- 20 Microprocessor internal RAM fault
  
- 31 Write checksum fault (IC E17)
- 32 Write checksum fault (IC E18)
- 33 Write checksum fault (IC E19)
- 34 Write checksum fault (IC G17)
- 35 Write checksum fault (IC G18)
- 36 Write checksum fault (IC G19)

FAULT CODE 62

SUB-FAULT CODES, FAULT CODE 62

---

- 40 LAST WORD signal stuck high
  - 41 MOVE TAG signal not functional
  - 42 COMMAND TAG signal not functional
  - 43 STATUS/DATA TAG signal not functional
  - 44 GCR status signal not functional
  - 45 High speed (HSPD) status signal not functional
  - 46 FLAG bit not functional
  - 47 One of the formatter status bits to the interface board not functional
  - 48 One of the device status bits to the interface board not functional
  - 49 Microprocessor parity generator not functional
  
  - 51 DATA STROBE signal from timer not functional
  - 52 Variable timer not functional
  - 53 Fixed timer (one-shot) not functional
  
  - 61 4 to 5 converter failed
  - 62 ECC generator failed
  - 63 CRC generator failed
  - 64 AUX CRC generator failed
  
  - 71 Write fifo available signal not functional
  - 72 Write data transfer complete signal not functional
  - 73 Write transfer check signal not functional
  
  - 81 Sense data path failed
  - 82 Device data path failed
  - 83 READ INVERT signal failed
-

FAULT CODE 63 - FORMATTER READ/WRITE INTERFACE  
HEALTH CHECK FAULT

Assumption: STU displays fault code 63 as a result of formatter read-formatter write interface health check fault.

NOTE

Following any corrective action, the unit should be powered off and powered on again.

- 010 1 Ensure that the formatter read and formatter write PWAs are firmly connected.
- 020 2 Replace formatter read PWA.
- 030 3 Replace formatter write PWA.

SUB-FAULT CODES, FAULT CODE 63

- 01 Read failed to go busy
- 02 Read stuck busy
- 03 Read detected an error
- 04 Read detected an error
- 05 RIMTY signal was in the wrong state
- 06 Write fifo available signal not functional
- 07 Data compare error
- 08 Write data transfer did not complete within specified time
- 09 Write transfer check
  
- 11 Read failed to go busy
- 12 Read stuck busy
- 13 Read detected an error
- 14 Read detected an error
  
- 21 READ GATE signal not functional
- 22 GCR ID signal not functional
- 23 FMK DET signal not functional
- 24 READ INTR signal not functional
- 25 READ CER signal not functional
- 26 BLOCK DET signal not functional
- 27 DATEN signal not functional
- 28 READ GATE signal failed with no interrupt set
- 29 Read buffer was empty with interrupt set

FAULT CODE 63

SUB-FAULT CODES, FAULT CODE 63

---

- 30 READ TAG signal not functional
  - 31 BYP VFO signal not functional
  - 32 REV signal not functional
  - 33 GCR signal not functional
  - 34 RAW signal not functional
  - 35 HSPD signal not functional
  - 36 SENSE signal not functional
  - 37 DIAG signal not functional
  - 38 SPACE signal not functional
  - 39 WFM signal not functional
  
  - 40 ERASE signal not functional
  - 41 ID signal not functional
  - 42 READ signal not functional
  - 43 DSTR signal not functional
-

FAULT CODE 64 - FORMATTER READ PWA HEALTH CHECK  
FAULT IN DATA LOOPBACK

Assumption: STU displays fault code 64 as a result of formatter read PWA health check fault in data loopback.

NOTE

Following any corrective action, the unit should be powered off and powered on again.

- 010 1 Replace formatter read PWA.
- 020 2 Replace formatter write PWA.

SUB-FAULT CODES, FAULT CODE 64

- 11 Read checksum fault (IC D3)
- 12 Read checksum fault (IC D2)
- 13 Read checksum fault (IC D1)
  
- 21 Read failed to go busy during sense operation
- 22 Read stuck busy during sense operation
- 23 Read detected an error during sense operation
- 24 Read detected an error during sense operation
- 25 No sense read data
- 26 Excess sense read data
  
- 31 Read failed to go busy during self-diagnostics
- 32 Read stuck busy during self-diagnostics
  
- 41 Read failed to go busy during ID operation
- 42 Read stuck busy during ID operation
- 43 Read detected an error during PE ID operation
- 44 Read detected an error during GCR ID operation
- 45 READ GATE signal failed during ID operation
- 46 GCR ID signal failed during ID operation

FAULT CODE 64

SUB-FAULT CODES, FAULT CODE 64

- 51 Read failed to go busy during a write file mark operation
- 52 Read stuck busy during a write file mark operation
- 53 Read detected an error during a write file mark operation
- 54 Read detected an error during a write file mark operation
- 55 FMK DET signal was stuck high
- 56 FMK DET signal was not set during a PE write file mark operation
- 57 FMK DET signal was not set during a GCR write file mark operation
  
- 61 Read failed to go busy during a space operation
- 62 Read stuck busy during a space operation
- 63 Read detected an error in PE during a space operation
- 64 Read detected an error in GCR during a space operation
- 65 BLOCK DET signal was not detected during a space operation
- 66 READ GATE signal was not detected during a space operation
  
- 71 Read failed to go busy during a read-after-write operation at high speed
- 72 Read stuck busy during a read-after-write operation at high speed
- 73 Read detected an error in PE during a read-after-write operation at high speed
- 74 Read detected an error in GCR during a read-after-write operation at high speed
  
- 81 Read failed to go busy during a read with data compare operation
- 82 Read stuck busy during a read with data compare operation
- 83 Read detected an error in PE during a read with data compare operation
- 84 Read detected an error in GCR during a read with data compare operation
- 85 Read buffer was empty during a read with data compare operation
- 86 Data compare error in PE detected by write
- 87 Data compare error in GCR detected by write

FAULT CODE 64

- 91 Read failed to go busy during a read-after-write operation using VFO.
  - 92 Read stuck busy during a read-after-write operation using VFO.
  - 93 Read detected an error in PE during a read-after-write operation using VFO.
  - 94 Read detected an error in GCR during a read-after-write operation using VFO.
-

FAULT CODE 65 - FORMATTER READ PWA HEALTH CHECK  
FAULT

Assumption: STU displays fault code 65 as a result of formatter read PWA health check fault.

NOTE

Following any corrective action, the unit should be powered off and powered on again.

010 1 Replace formatter read PWA.

SUB-FAULT CODES, FAULT CODE 65

---

- 11 ALUZ signal not functional
- 12 ALUZ signal not functional
- 13 ALUN signal not functional
- 14 Arithmetic operation failed
- 15 Logical operation failed
  
- 20-22 Microprocessor internal RAM fault
  
- 30 DATA STROBE signal stuck high
- 31 DATA STROBE signal stuck low
- 32 Variable timer fault
- 33 Variable timer overflow fault
  
- 40 One of the flag bits cannot be set
- 41 One of the flag bits cannot be reset
- 42 Microprocessor parity generator fault
- 43 Microprocessor parity generator fault
  
- 50 Illegal count fault (contained within deskew buffer)
- 51 Read transfer check not functional
- 52 Read data buffer input parity error not functional
- 53 Illegal count could not be reset by ILLEGAL COUNT ENABLE signal



FAULT CODE 65

SUB-FAULT CODES, FAULT CODE 65

---

- 60 Error correction logic did not correct data properly
  - 61 3ORGT signal not functional
  - 62 SGL PNTR, SGL CORR, or MLT PTR signal not functional
  - 63 DUAL signal not functional
  - 64 Error correction pointer from error correction logic was incorrect
  - 65 DUAL CORR signal not functional
  - 66 ECCZ signal not functional
  - 67 VRCZ signal not functional
  - 68 Error correction did not complete (ECDONE = 1) in nine clock cycles
  - 69 UNCORR signal not functional
  
  - 70 ECC generator failed
  - 71 CRC generator failed
  - 72 AUX CRC generator failed
  - 73 ECC generator failed in reverse mode
  - 74 CRC generator failed in reverse mode
  - 75 AUX CRC generator failed in reverse mode
  
  - 80 DATA BLOCK signal not functional
  - 81 7ORGT signal not functional
  - 82 GCR TM signal not functional
  - 83 PROM address for block PROM (IC C13) not functional
  - 84 ANY BLOCK signal not functional
  
  - 91 Deskew buffer READY signal not functional
  - 92 DEAD TRACK signal from a deskew buffer not functional
  - 93 Buffer READY signal did nt set for all dead track conditions.
-

FAULT CODE 66 - FORMATTER/ADAPTER INTERFACE  
HEALTH CHECK

Assumption: STU displays fault code 66 as a result of  
formatter/interface health check fault.

NOTE

Following any corrective action, the  
unit should be powered off and powered  
on again.

- 010 1 Replace interface PWA.
- 020 2 Replace formatter write PWA.

SUB-FAULT CODES, FAULT CODE 66

- 00 Adapter interface did not respond to a diagnostic request
- 01 Command from adapter contained a parity error
- 02 Command from adapter was incorrect
- 03 Adapter health check timeout
  
- 11 Command register bit in error
- 12 DATA BUSY signal not functional
- 13 Write data bus check failed
- 14 No data was received during write data bus check
- 15 LAST WORD signal not functional
- 16 Excessive data was received during write data bus check
- 17 Adapter detected an error during write data bus check
- 18 During read data bus check, the TRANSFER COMPLETE signal stuck high.
- 19 Adapter detected an error during read data bus check
  
- 20 STATUS SELECT signal not functional

FAULT CODE 67 - INTERFACE HEALTH CHECK

Assumption: STU displays fault code 67 as a result of interface PWA health check fault.

NOTE

Following any corrective action, the unit should be powered off and powered on again.

010 1 Replace interface PWA.

FAULT CODE 68 - INTERFACE CHECKSUM

Assumption: STU displays fault code 68 as a result of interface PWA checksum fault.

NOTE

Following any corrective action, the unit should be powered off and powered on again.

010 1 Replace interface PWA.

REMOTE DIAGNOSTICS FAULT

Assumption: The STU displays fault code 69 as a result of remote diagnostic fault.

NOTE

Following any corrective action, the unit should be powered off and powered on again.

- |     |          |          |  |
|-----|----------|----------|--|
| 010 | Y        | N        | Press CE switch. Sub-fault code 00-04?   |
| 020 | <u>1</u> |          | Refer to sub-fault codes below.  |
| 030 |          | 1        | Replace servo-control PWA. (Refer to set-up tests in servo-control PWA removal/replacement procedure.) |
| 040 |          | 2        | Replace formatter write PWA.   |
| 050 |          | <u>3</u> | Replace interface PWA.   |

SUB-FAULT CODES, FAULT CODE 69

- |    |   |
|----|---|
| 00 | Test cannot be run remotely                                   |
| 01 | RESET button was pushed while executing a remote diagnostic   |
| 02 | Drive was busy and test could not be executed                 |
| 03 | Present drive mode must be terminated prior to test execution |
| 04 | Formatter was busy and test could not be executed             |



## TEST DESCRIPTIONS

### GENERAL INFORMATION

The diagnostic test information is presented under the following headings:

- o Test Requirement - Conditions which must be met before execution of the test.
- o Test Description - A brief explanation of what the test is all about.
- o Test Options - A list of the options and the option code applicable to the test.
- o Test Sequence - A step-by-step breakdown of what happens during execution of the test. The test sequence is performed automatically when EXECUTE switch is pressed.
- o Possible Diagnostic Codes - A list of the possible diagnostic codes associated with each test. Besides the test successful (00) code, diagnostic fault codes (01-69), or diagnostic termination codes (70-99) may be displayed on the operator panel. For the meaning of the fault codes and associated corrective action, refer to the Structured Analysis Method (SAM). The meaning of the termination codes is listed within each test description. Keep in mind that the meaning of a termination code may vary from test to test, and that you must refer to a specific test to determine the meaning of its associated termination codes.

## INITIATING A DIAGNOSTIC TEST AND SELECTING OPTIONS

After ensuring that the test requirements are met, follow the steps below to initiate a diagnostic test.

1. While pressing the CE switch, press the TEST switch.
  - a. The DIAGNOSTIC indicator lights.
  - b. The display panel indicates 00.
2. Press the STEP switch.
  - a. The display number increments each time the STEP switch is pressed, or increments automatically if the STEP switch is held pressed.
  - b. To facilitate test number selection, use the following procedure. Example: Test 39 selection required.
    - Press the STEP switch until 03 appears on the display panel.
    - Press the TEST switch and the 3-digit transfers to the left.
    - The display now indicates 30.
    - Press the STEP switch again until the display increments from 30 to 39.
  - c. If test options (see test descriptions) are available and desired, press and hold the CE switch, and then press the EXECUTE switch while the CE switch is held pressed. The display will indicate 00. The STEP switch is then pressed to select the desired option.
3. Press the EXECUTE switch.
  - a. The test is initiated.

If the test runs to completion, the display panel indicates 00. If the test fails, the display panel indicates the fault code.



## LIST OF DIAGNOSTIC TESTS

The diagnostic tests are listed below in numerical sequence with the options available for each test.

<u>TEST NO.</u>	<u>DESCRIPTION</u>	<u>OPTION*</u>
01	Functional Fault Detection Diagnostic	X
02	Tension Fault Isolation Diagnostic	X
03	Velocity Fault Isolation Diagnostic	X
04	Reserved	
05	Enable Buffer From Operator Panel	X
06	Disable Buffer From Operator Panel	X
07-09	Reserved	
10	Forward at Option Speed to EOT	S
11	Reverse at Option Speed to BOT	S
12	Forward Ramps at Option Speed to EOT	S
13	Reverse Ramps at Option Speed to BOT	S
14	GCR Start/Stop Repositioning	L
15	75 ips Forward Ramps to EOT	L
16	75 ips Reverse Ramps to BOT	L
17	75 ips Repositioning	L
18	75 ips Forward to EOT	L
19	75 ips Reverse to BOT	L
20	Unit Internal Fault Detection Diagnostic	B
21	Write 2K Byte Records in PE Mode at 25 ips to EOT (at EOT, Rewind to BOT)	B
22	Read at 25 ips to EOT (at EOT, Rewind to BOT)	B
23	Write 2K Byte Records in PE Mode at 75 ips to EOT (At EOT, Rewind to BOT)	B
24	Read at 75 ips to EOT (at EOT, Rewind to BOT)	B
25	Write 2K Byte Records in GCR Mode at 25 ips to EOT (at EOT, Rewind to BOT)	B
26	Write 2K Byte Records in GCR Mode at 75 ips to EOT (at EOT, Rewind to BOT)	B
27	Reserved	
28	Perform Command Stack entered by Diagnostic 97 at 25 ips.	B
29	Perform Command Stack entered by Diagnostic 97 at 75 ips.	B

\* See Key at end of test list.

<u>TEST NO.</u>	<u>DESCRIPTION</u>	<u>OPTION*</u>
30	Check Read Amplitudes at 25 and 75 ips to be within tolerance of 0.8 volt.	B
31	Determine EGC Gains at 25 and 75 ips and store gains in Backup Memory. Then check Read Amplitudes at 25 and 75 ips to be within tolerance of 0.1 volt.	X
32	Check Read Amplitudes at 25 and 75 ips with pre-recorded all 1's tape with tolerance of 0.3 volt.	B
33	Determine EGC Gains at 25 ips and store gains in Backup Memory.	X
34	Determine EGC Gains at 75 ips and store gains in Backup Memory.	X
35-36	Reserved	
37	Determine Velocity Servo Correction Multiplier and store multiplier in Backup Memory.	X
38	Apply approximately 8-ounce tension by pulsing supply reel with take-up reel in Stoplock.	X
39	Write Option Pattern in PE Mode to EOT at 25 ips (at EOT, Rewind to BOT, repeat test).	P
40	Write Option Pattern in PE Mode to EOT at 75 ips (at EOT, Rewind to BOT, repeat test).	P
41	Stoplock Take-up Reel	X
42	Enable Tension Servo	X
43	Turn-on Pump	X
44	Fast Search Forward for EOT	X
45	Refresh Scope Loop	X
46	Velocity DAC Scope Loop	X
47	Servo-Control Microprocessor Outputs Scope Loop	X
48	Enable Compressor Power-Down Timer	X
49	Reserved	
50	Enable Power-On Autoload	X

\* See Key at end of test list.

<u>TEST NO.</u>	<u>DESCRIPTION</u>	<u>OPTION*</u>
51	Reserved	
52	Write Option Pattern in GCR Mode to EOT at 25 ips (at EOT, Rewind to BOT, repeat test).	P
53	Write Option Pattern in GCR Mode to EOT at 75 ips (at EOT, Rewind to BOT, repeat test).	P
54	Examine/Change Write Current Levels	X
55	Drive Internal Diagnostic	B
56	Formatter Internal Diagnostic	B
57	Interface Internal Diagnostic	B
58	Loop Write-to-Read thru Drive Interface	B
59	Loop Write-to-Read thru Read/Write	B
60	Loop Write-to-Read thru Formatter	B
61	Take-up Motor and Power Amp Full Capability Detection Test	X
62	Take-up Fine-Line Tach Fault Detection	X
63	Reserved	
64	Auto-Write Current Level Adjustment	X
65-79	Reserved	
80	Retain Tape Position On Power-Down	X
81	Select Early EOT Point	X
82-83	Reserved	
84	Select/Examine STU Options	X
85-90	Reserved	
91	Functional Fault Detection (Same as Operator Test 01 except: a) Will start in Loaded or Unloaded condition, b) Bypass EGC test.)	B
92-96	Reserved	
97	Read/Write Command Stack Generation Diagnostic	X

## OPTION KEY

X = No options.

L = Test will loop. No options.

B = CE may use the following options.

00 = Halt if read or write errors exceed limits specified, halt on completion of test (Default option).

01 = Loop on test, halt if read or write errors exceed limit specified on any given pass.

02 = Loop on test, bypass read or write error halts.

### NOTE

Option of halting or bypassing errors only exists for read/write type errors; all other errors will cause test to halt, with the appropriate fault code displayed, regardless of the option selected.

P = CE may use the following option patterns:

00 = All ones pattern

01 = One-half frequency pattern

02 = One-third frequency pattern (GCR only)

S = CE may use the following option speeds:

00 = 25 ips speed

01 = 12.5 ips speed

TEST 01: FUNCTIONAL FAULT DETECTION TEST  
(FOR OPERATOR)

TEST REQUIREMENT: A write-enabled scratch tape must be threaded, but not loaded.

DESCRIPTION: Test 01 executes various functions normally performed during functional operations. Unit halts with appropriate fault code if a functional fault occurs. (Approximately seven minutes is required to perform this test.)

TEST OPTIONS: None.

TEST SEQUENCE:

- a. Light ONLINE and RESET indicators. Increment display from 00 to 99. Put out ONLINE and RESET indicators. Display 01.
- b. Load tape.
- c. Check read amplitudes at low and high speeds. REWIND.
- d. WRITE 100 blocks in PE mode at 25 ips start/stop (see NOTE 1).
- e. SPACE REVERSE, ERASE, and WRITE FILE MARK (check for FILE MARK DETECTED). SPACE REVERSE and check for FILE MARK DETECTED. READ FORWARD and again check for FILE MARK DETECTED.
- f. READ REVERSE 100 blocks at 25 ips start/stop.
- g. READ FORWARD 100 blocks at 25 ips start/stop.
- h. Repeat steps d thru g at 25 ips streaming.
- i. Repeat steps d thru g at 75 ips streaming.
- j. WRITE 10 blocks at 75 ips thrashing (see NOTE 2).
- k. READ REVERSE 10 blocks at 75 ips thrashing.
- l. READ FORWARD 10 blocks at 75 ips thrashing.
- m. REWIND.
- n. READ FORWARD 300 blocks at 75 ips streaming. Check for FILE MARK DETECTED at blocks 100, 200, and 300.

TEST 01: (Cont'd)

- o. REWIND.
- p. Repeat steps d thru n for GCR mode but SPACE REVERSE where READ REVERSE is specified.
- q. WRITE to EOT in GCR mode at 75 ips streaming (see NOTE 1).
- r. SPACE REVERSE 1000 records at 75 ips streaming (reposition after every 250 records).
- s. Write to EOT in GCR mode at 25 ips streaming.
- t. REWIND.

NOTE 1. Data blocks written are 2K bytes with an incrementing pattern starting at zero for each block.

NOTE 2. Data blocks written are 256 bytes with an incrementing pattern starting at zero for each block.

POSSIBLE DIAGNOSTIC CODES:

00 - Functional test is successful  
Fault Codes  
01 thru 69 - Refer to Structured Analysis Method (SAM)

TEST 02: TENSION FAULT ISOLATION  
(FOR OPERATOR)

TEST REQUIREMENT: Tape must be threaded, but not loaded

Valid fault code must be displayed after execution of test 01. See NOTE below.

NOTE: Test 02 will run only if test 01 terminates in one of the following fault codes: 22, 24, 26, 30, 31, 36.

TEST DESCRIPTION: Test 02 isolates servo faults by checking various assemblies of the STU.

TEST OPTIONS: None.

TEST SEQUENCE:

- a. Verify operator door is closed and tape is not loaded.
- b. Verify refresh DAC of servo-control PWA is operational. If not, display termination code 80.
- c. Verify supply reel power amp is operational. If not, display termination code 81.
- d. Verify take-up reel power amp is operational. If not, display termination code 82.
- e. Verify demand velocity DAC of servo-control PWA is operational. If not, display termination code 83.
- f. Move take-up reel slightly in forward direction. Check for correct count of quarter-tach pulses. If incorrect, display termination code 84.
- g. Repeat step f in the reverse direction. Display termination code 84 if tach count is incorrect.
- h. Verify velocity feedback loop of servo-control PWA is operational by putting take-up motor in stoplock mode, and monitoring forward and reverse quarter-tachs. Display termination code 85 if any fault is detected.

## TEST 02: (Cont'd)

- i. Verify that tension comparators on servo-control PWA are operational. Vary tension offsets and monitor status of tension level status lines. If any fault is detected, display termination code 87.
- j. With compressor off, zero tension offsets. If fault occurs, display termination code 97.
- k. Turn on compressor. If take-up sensor detects at least 2.0 ounces of tension, display termination code 90. If supply sensor detects at least 2.0 ounces of tension, display termination code 89.
- l. Enable take-up servo. Move take-up reel from 0 ips to 6 ips in forward direction.
- m. If both sensors do not detect at least 2.0 ounces of tension within 15 seconds, display termination code 91.
- n. If, during this 15 seconds, the supply sensor does not detect 2.0 ounces of tension within 100 milliseconds after take-up sensor, display termination code 74. If take-up sensor does not detect 2.0 ounces within 100 milliseconds after file sensor, display termination code 72.
- p. Move supply reel slowly in reverse direction while take-up reel is moving forward at 6 ips. If neither sensor detects at least 16 ounces of tension within 500 milliseconds, display termination code 92.
- q. If, during this 500 milliseconds, the supply sensor does not detect 16 ounces of tension within 100 milliseconds after take-up sensor, display termination code 75. If take-up sensor does not detect 16 ounces of tension within 100 milliseconds after file sensor, display termination code 73.
- r. Stop moving file reel in reverse direction. If tension detected on both sensors is not within limits in 100 milliseconds, display termination code 98.
- s. Stop reel motion. Display fault code 00 to indicate test is successful.



TEST 02: (Cont'd)

POSSIBLE DIAGNOSTIC CODES:

- 00 - Tension test is successful
- Fault Codes
- 10 thru 69 - Refer to Structured Analysis Method (SAM)
- Termination Codes
- 70 - Test requirement not met. See test 02 requirements.
- 71 - Tape loaded fault.
- 72 - Take-up sensor fault 1
- 73 - Take-up sensor fault 2
- 74 - Supply sensor fault 1
- 75 - Supply sensor fault 2
- 80 - Refresh DAC fault
- 81 - Supply power amp fault
- 82 - Take-up power amp fault
- 83 - Demand velocity DAC fault
- 84 - Take-up motor/tach fault
- 85 - Velocity feedback loop fault
- 86 - Take-up comparator fault
- 87 - Supply comparator fault
- 89 - Supply sensor - 0 fault
- 90 - Take-up sensor - 0 fault
- 91 - Compressor failure fault
- 92 - Filter/Regulator, compressor, servo-control PWA fault
- 97 - Servo-Control PWA, sensor intermittent fault
- 98 - Servo-Control PWA, power amp fault

**TEST 03: VELOCITY FAULT ISOLATION**  
**(FOR OPERATOR)**

**TEST REQUIREMENT:** Tape must not be threaded.

Valid fault code must be displayed after execution of test 01. See NOTE below.

**NOTE:** Test 03 will run only if test 01 terminates in one of the following fault codes: 03, 04, 06, 22, 25, 26, 30, 31, 32, 33, 35, 36, 48, 52.

**TEST DESCRIPTION:** Test 03 isolates velocity servo faults by checking the take-up motor/tach assembly and the velocity servo loop.

**TEST OPTIONS:** None.

**TEST SEQUENCE:**

- a. Check if the operator door is closed and tape is absent.
- b. Ramp up to 4 ips.
- c. Check if distance between two consecutive quarter tachs is within tolerable limits.
- d. If, after five tries, at least once, the distance between two consecutive quarter tachs is within limits, go to step f.
- e. Display termination code 96.
- f. Check that the distance between all consecutive quarter tachs is within tolerable limits.
- g. If distance between any two consecutive quarter tachs is not within limits, report fault, otherwise, go to step i.
- h. Repeat steps e and f. If the error is detected five times, display termination code 98.
- i. Apply diagnostic lines to move take-up motor in forward direction from 0 to 75 ips, and measure time it requires to ramp-up. Stop take-up motor.
- j. Calculate motor constant from this data.

## TEST 03: (Cont'd)

- k. If motor constant is within range, go to step e. If motor constant is out of range the first time, repeat steps i and j. Otherwise, display termination code 84.
- l. Apply full current to move take-up motor in forward direction from 0 to 75 ips, and measure time it requires to ramp-up. Stop take-up motor.
- m. If power amp is not capable of delivering full current in forward direction, flag a fault, otherwise, go to step o.
- n. If fault is the first time, repeat steps l and m, otherwise, display termination code 82.
- o. Apply full current to move take-up motor in reverse direction from 0 to 75 ips, and measure time it requires to ramp-up. Stop take-up motor.
- p. If power amp is not capable of delivering full current in reverse direction, flag a fault, otherwise, go to step r.
- q. If fault is the first time, repeat steps o and p, otherwise, display termination code 82.
- r. Display termination code 00 to indicate successful completion of test.

## POSSIBLE DIAGNOSTIC CODES:

- 00 - Velocity test is successful
- Fault Codes
- 10 thru 69 - Refer to Structured Analysis Method (SAM)
- Termination Codes
- 82 - Take-up power amp fault
- 84 - Take-up motor/tach fault
- 94 - Tape threaded fault
- 95 - Formatter interrupt received while test in progress.
- 96 - Servo loop fault
- 98 - Take-up motor/tach fault

TEST 05: ENABLE BUFFER FROM OPERATOR PANEL

TEST REQUIREMENT: Test 05 must be enabled by test 84 (bit 3 of byte 2 = 1). STU must have buffered enhanced interface.

TEST DESCRIPTION: By means of test 05, buffer operation can be enabled from the operator panel.

TEST OPTIONS: None.

POSSIBLE DIAGNOSTIC CODES:

00 - Test is successful

Termination Codes

90 - Buffer already enabled; test 05 disabled

91 - Buffer still disabled; test 05 disabled.

TEST 06: DISABLE BUFFER FROM OPERATOR PANEL

TEST REQUIREMENT: Test 06 must be enabled by test 84 (bit 3 of byte 2 = 1). STU must have buffered enhanced interface.

TEST DESCRIPTION: By means of test 06, buffer operation can be disabled from the operator panel.

TEST OPTIONS: None.

POSSIBLE DIAGNOSTIC CODES:

00 - Test is successful

Termination Codes

90 - Buffer already disabled; test 06 disabled

91 - Buffer still enabled; test 06 disabled.

CE TEST 10: FORWARD AT OPTION SPEED TO EOT

TEST REQUIREMENT: Tape must be loaded.

TEST DESCRIPTION: Test 10 exercises the transport in a continuous mode at the selected option speed in the forward direction. When EOT is detected, tape is stopped and the selected option speed continuous mode is executed in reverse direction. When BOT is detected, the routine starts again. Manual intervention is required to terminate the test.

TEST OPTIONS: 00 = 25 ips speed  
01 = 12.5 ips speed

## TEST SEQUENCE:

- a. Check if the operator door is closed and tape is loaded.
- b. Run forward continuously the selected option speed until EOT is detected.
- c. Stop and run reverse continuously at the selected option speed until BOT is detected.
- d. Stop motion and go to step b.

## POSSIBLE DIAGNOSTIC CODES:

## Faut Codes

10 thru 69 - Refer to Structured Analysis Method (SAM)

## Termination Codes

70 - Tape not loaded fault

CE TEST 11: REVERSE AT OPTION SPEED TO BOT

TEST REQUIREMENT: Tape must be loaded.

TEST DESCRIPTION: Test 11 exercises the transport in a continuous mode at the selected option speed in the reverse direction. When BOT is detected, tape is stopped and the selected option speed continuous mode is executed in forward direction. When EOT is detected, the routine starts again. Manual intervention is required to terminate the test.

TEST OPTIONS:       00 = 25 ips speed  
                      01 = 12.5 ips speed

## TEST SEQUENCE:

- a. Check if the operator door is closed and tape is loaded.
- b. Run reverse continuously the selected option speed until BOT is detected.
- c. Stop and run forward continuously at the selected option speed until EOT is detected.
- d. Stop motion and go to step b.

## POSSIBLE DIAGNOSTIC CODES:

## Fault Codes

10 thru 69 - Refer to Structured Analysis Method (SAM)

## Termination Codes

70 - Tape not loaded fault

CE TEST 12: FORWARD RAMPS AT OPTION SPEED TO EOT

TEST REQUIREMENT: Tape must be loaded.

TEST DESCRIPTION: Test 12 exercises the transport in a start/stop mode at the selected option speed in the forward direction. When EOT is detected, the same the selected option speed start/stop mode is executed in the reverse direction. When BOT is detected, the routine starts again. Manual intervention is required to terminate the test.

TEST OPTIONS:       00 = 25 ips speed  
                      01 = 12.5 ips speed

## TEST SEQUENCE:

- a. Check if the operator door is closed and tape is loaded.
- b. Run forward at the selected option speed for 30 ms.
- c. Stop and pause for 100 ms.
- d. Repeat steps b and c until EOT is detected.
- e. Run reverse at the selected option speed for 30 ms.
- f. Stop and pause for 100 ms.
- g. Repeat steps e and f until BOT is detected.
- h. Go to step b.

## POSSIBLE DIAGNOSTIC CODES:

Fault Codes  
10 thru 69 - Refer to Structured Analysis Method (SAM)  
Termination Codes  
70 - Tape not loaded fault



CE TEST 13: REVERSE RAMPS AT OPTION SPEED TO BOT

TEST REQUIREMENT: Tape must be loaded.

TEST DESCRIPTION: Test 13 exercises the transport in a start/stop mode at the selected speed option in the reverse direction. When BOT is detected, the same the selected speed option start/stop mode is executed in the forward direction. When EOT is detected, the routine starts again. Manual intervention is required to terminate the test.

TEST OPTIONS: 00 = 25 ips speed  
01 = 12.5 ips speed

## TEST SEQUENCE:

- a. Check if the operator door is closed and tape is loaded.
- b. Run reverse at the selected speed option for 30 ms.
- c. Stop and pause for 100 ms.
- d. Repeat steps b and c until BOT is detected.
- e. Run forward at the selected speed option for 30 ms.
- f. Stop and pause for 100 ms.
- g. Repeat steps e and f until EOT is detected.
- h. Go to step b.

## POSSIBLE DIAGNOSTIC CODES:

## Fault Codes

10 thru 69 - Refer to Structured Analysis Method (SAM)

## Termination Codes

70 - Tape not loaded fault

CE TEST 14: GCR START/STOP REPOSITIONING

TEST REQUIREMENT: Tape must be loaded.

TEST DESCRIPTION: Test 14 is a routine emulating GCR start/stop repositioning. It repositions the tape in the forward direction. When EOT is detected, it repositions the tape in the reverse direction. When BOT is detected, the routine starts again. Manual intervention is required to terminate the test.

TEST OPTIONS: None.

## TEST SEQUENCE:

- a. Verify that operator door is closed and tape is loaded.
- b. Run forward at 25 ips for 100 ms.
- c. Run reverse at 12.5 ips for 1 ms.
- d. Repeat steps b and c until EOT is detected.
- e. Run forward at 12.5 ips for 1 ms.
- f. Run reverse at 25 ips for 100 ms.
- g. Repeat steps e and f until BOT is detected.
- h. Go to step b.

## POSSIBLE DIAGNOSTIC CODES:

## Fault Codes

10 thru 69 - Refer to Structured Analysis Method (SAM)

## Termination Codes

70 - Tape not loaded fault

CE TEST 15: FORWARD 75 IPS RAMPS

TEST REQUIREMENT: Tape must be loaded.

TEST DESCRIPTION: Test 15 exercises the transport in a start/stop mode at 75 ips in the forward direction. When EOT is detected, the same 75 ips start/stop mode is executed in the reverse direction. When BOT is detected, the routine starts again. Manual intervention is required to terminate the test.

TEST OPTIONS: None.

## TEST SEQUENCE:

- a. Check if the operator door is closed and tape is loaded.
- b. Run forward at 75 ips for 30 ms.
- c. Stop and Pause for 400 ms.
- d. Repeat steps b and c until EOT is detected.
- e. Run reverse at 75 ips for 30 ms.
- f. Stop and pause for 400 ms.
- g. Repeat steps e and f until BOT is detected.
- h. Go to step b.

## POSSIBLE DIAGNOSTIC CODES:

## Fault Codes

10 thru 69 - Refer to Structured Analysis Method (SAM)

## Termination Codes

70 - Tape not loaded fault

CE TEST 16: REVERSE 75 IPS RAMPS

TEST REQUIREMENT: Tape must be loaded.

TEST DESCRIPTION: Test 16 exercises the transport in a start/stop mode at 75 ips in the reverse direction. When BOT is detected, the same 75 ips start/stop mode is executed in the forward direction. When EOT is detected, the routine starts again. Manual intervention is required to terminate the test.

TEST OPTIONS: None.

## TEST SEQUENCE:

- a. Check if the operator door is closed and tape is loaded.
- b. Run reverse at 75 ips for 30 ms.
- c. Stop and Pause for 400 ms.
- d. Repeat steps b and c until BOT is detected.
- e. Run reverse at 75 ips for 30 ms.
- f. Stop and pause for 400 ms.
- g. Repeat steps e and f until EOT is detected.
- h. Go to step b.

## POSSIBLE DIAGNOSTIC CODES:

## Fault Codes

10 thru 69 - Refer to Structured Analysis Method (SAM)

## Termination Codes

70 - Tape not loaded fault

CE TEST 17: 75 IPS REPOSITIONING

TEST REQUIREMENT: Tape must be loaded.

TEST DESCRIPTION: Test 17 is a repositioning routine at 75 ips. It repositions the tape in the forward direction. When EOT is detected, it repositions the tape in the reverse direction. When BOT is detected, the routine starts again. Manual intervention is required to terminate the test.

TEST OPTIONS: None.

## TEST SEQUENCE:

- a. Check if the operator door is closed and tape is loaded.
- b. Run forward at 75 ips for 400 ms.
- c. Run reverse at 75 ips for 100 ms.
- d. Repeat steps b and c until EOT is detected.
- e. Run forward at 75 ips for 100 ms.
- f. Run reverse at 75 ips for 400 ms.
- g. Repeat steps e and f until BOT is detected.
- h. Go to step b.

## POSSIBLE DIAGNOSTIC CODES:

## Fault Codes

10 thru 69 - Refer to Structured Analysis Method (SAM)

## Termination Codes

70 - Tape not loaded fault

CE TEST 18: FORWARD 75 IPS CONTINUOUS

TEST REQUIREMENT: Tape must be loaded.

TEST DESCRIPTION: Test 18 exercises the transport in a continuous mode at 75 ips in the forward direction. When EOT is detected, tape is stopped and 75 ips continuous mode is executed in the reverse direction. When BOT is detected, the routine starts again. Manual intervention is required to terminate the test.

TEST OPTIONS: None.

## TEST SEQUENCE:

- a. Check if the operator door is closed and tape is loaded.
- b. Run forward continuously 75 ips until EOT is detected.
- c. Stop and run reverse continuously at 75 ips until BOT is detected.
- d. Stop motion and go to step b.

## POSSIBLE DIAGNOSTIC CODES:

## Fault Codes

10 thru 69 - Refer to Structured Analysis Method (SAM)

## Termination Codes

70 - Tape not loaded fault

CE TEST 19: REVERSE 75 IPS CONTINUOUS

TEST REQUIREMENT: Tape must be loaded.

TEST DESCRIPTION: Test 19 exercises the transport in a continuous mode at 75 ips in the reverse direction. When BOT is detected, tape is stopped and 75 ips continuous mode is executed in the forward direction. When EOT is detected, the routine starts again. Manual intervention is required to terminate the test.

TEST OPTIONS: None.

## TEST SEQUENCE:

- a. Check if the operator door is closed and tape is loaded.
- b. Run reverse continuously 75 ips until BOT is detected.
- c. Stop and run forward continuously at 75 ips until EOT is detected.
- d. Stop motion and go to step b.

## POSSIBLE DIAGNOSTIC CODES:

## Fault Codes

10 thru 69 - Refer to Structured Analysis Method (SAM)

## Termination Codes

70 - Tape not loaded fault

**CE TEST 20: UNIT INTERNAL DIAGNOSTICS**

**TEST REQUIREMENT:** Tape must not be loaded.

**TEST DESCRIPTION:** Test 20 checks out the internal hardware of the drive, the formatter and interface. It also checks out the bus between the formatter and interface.

**TEST OPTIONS:**

- 00 = Halt if read or write errors exceed limits specified, halt on completion of test (Default option).
- 01 = Loop on test, halt if read or write errors exceed limit specified on any given pass.
- 02 = Loop on test, bypass read or write error halts.

**NOTE**

Option of halting or bypassing errors only exists for read/write type errors; all other errors will cause test to halt, with appropriate fault code displayed, regardless of the option selected. Wait at least 20 seconds after Test 20 is over before placing STU on-line.

**TEST SEQUENCE:**

- a. Check out the device internal hardware.
- b. Check out the formatter internal hardware.
- c. Check out the bus between the formatter and interface.
- d. Check out the interface internal hardware.

**POSSIBLE DIAGNOSTIC CODES:**

00 - Test is successful

**Fault Codes**

- 50 - Drive health check fault
- 56 - Processor communication fault
- 62 - Formatter write PWA health check fault
- 63 - Formatter read/write interface health check fault
- 64 - Formatter read PWA health check fault in data loopback
- 65 - Formatter read PWA health check fault
- 66 - Formatter interface health check fault
- 67 - Interface health check fault
- 68 - Interface checksum fault



CE TEST 21: 25 IPS STREAMING WRITE TO EOT IN PE MODE

TEST REQUIREMENT: A write-enabled scratch tape must be loaded.

TEST DESCRIPTION: Test 21 rewinds the tape and writes 2K byte records, incrementing data pattern to EOT at 25 ips streaming mode. On detection of EOT, it rewinds and positions at BOT. If a write error occurs, the unit performs Backspace, Erase, and attempts to write again. If more than 5 consecutive erases are required, the test terminates with a write fault. If 32 erases are required in one complete pass, the test terminates with a write fault. All functional checks are active throughout test.

TEST OPTIONS: 00 = Halt if read or write errors exceed limits specified, halt on completion of test (Default option).  
 01 = Loop on test, halt if read or write errors exceed limit specified on any given pass.  
 02 = Loop on test, bypass read or write error halts.

## NOTE

Option of halting or bypassing errors only exists for read/write type errors; all other errors will cause test to halt, with appropriate fault code displayed, regardless of the option selected.

## TEST SEQUENCE:

- a. REWIND to BOT (this function is not performed if 02 option is selected).
- b. WRITE 2K byte records at 25 ips streaming to EOT.
- c. REWIND to BOT.

## POSSIBLE DIAGNOSTIC CODES:

00 - Test is successful  
 Fault Codes  
 03 - ID check  
 04 - Low speed write error  
 08 - Noise detected while erasing  
 09 - Hardware failure  
 10 thru 69 - Refer to Structured Analysis Method (SAM)  
 Termination Codes  
 70 - Tape not loaded fault

CE TEST 22: 25 IPS READ TO EOT

TEST REQUIREMENT: A pre-written tape must be loaded.

TEST DESCRIPTION: Test 22 rewinds the tape and reads any pre-written tape to EOT at 25 ips. Any read error halts the test with a fault code. All functional checks are active. On detection of EOT, it rewinds and positions at BOT.

TEST OPTIONS:

- 00 = Halt if read or write errors exceed limits specified, halt on completion of test (Default option).
- 01 = Loop on test, halt if read or write errors exceed limit specified on any given pass.
- 02 = Loop on test, bypass read or write error halts.

## NOTE

Option of halting or bypassing errors only exists for read/write type errors; all other errors will cause test to halt, with appropriate fault code displayed, regardless of the option selected.

## TEST SEQUENCE:

- a. Rewind to BOT (this function is not performed if 02 option is selected).
- b. Read records at 25 ips streaming to EOT.
- c. Rewind to BOT.

## POSSIBLE DIAGNOSTIC CODES:

00 - Test is successful  
 Fault Codes  
 03 - ID check  
 05 - Low speed read error  
 09 - Hardware failure  
 10 thru 69 - Refer to Structured Analysis Method (SAM)  
 Termination Codes  
 70 - Tape not loaded fault

**CE TEST 23: 75 IPS STREAMING WRITE TO EOT IN PE MODE**

**TEST REQUIREMENT:** A write-enabled scratch tape must be loaded.

**TEST DESCRIPTION:** Test 23 rewinds the tape and writes 2K byte records, incrementing data patterns to EOT at 75 ips in streaming mode. On detection of EOT, it rewinds and positions at BOT. If a write error occurs, the unit performs BACKSPACE, ERASE, and attempts to write again. If more than 5 consecutive erases are required, the test terminates with a write fault. If 32 erases are required in one complete pass, the test terminates with a write fault. All functional checks are active throughout test.

**TEST OPTIONS:**

- 00 = Halt if read or write errors exceed limits specified, halt on completion of test (Default option).
- 01 = Loop on test, halt if read or write errors exceed limit specified on any given pass.
- 02 = Loop on test, bypass read or write error halts.

**NOTE**

Option of halting or bypassing errors only exists for read/write type errors; all other errors will cause test to halt, with appropriate fault code displayed, regardless of the option selected.

**TEST SEQUENCE:**

- a. REWIND to BOT (this function is not performed if 02 option is selected).
- b. WRITE 2K byte records at 75 ips streaming to EOT.
- c. REWIND to BOT.

**POSSIBLE DIAGNOSTIC CODES:**

00 - Test is successful  
 Fault Codes  
 03 - ID check  
 06 - High speed write error  
 08 - Noise detected while erasing  
 09 - Hardware failure  
 10 thru 69 - Refer to Structured Analysis Method (SAM)  
 Termination Codes  
 70 - Tape not loaded fault

CE TEST 24: 75 IPS READ TO EOT

TEST REQUIREMENT: A pre-written tape must be loaded.

TEST DESCRIPTION: Test 24 rewinds the tape and reads any pre-written tape to EOT at 75 ips. Any read error halts the test with a fault code. All functional checks are active. On detection of EOT, it rewinds and positions at BOT.

TEST OPTIONS:

- 00 = Halt if read or write errors exceed limits specified, halt on completion of test (Default option).
- 01 = Loop on test, halt if read or write errors exceed limit specified on any given pass.
- 02 = Loop on test, bypass read or write error halts.

## NOTE

Option of halting or bypassing errors only exists for read/write type errors; all other errors will cause test to halt, with appropriate fault code displayed, regardless of the option selected.

## TEST SEQUENCE:

- a. REWIND to BOT (this function is not performed if 02 option is selected).
- b. READ records at 75 ips streaming to EOT.
- c. REWIND to BOT.

## POSSIBLE DIAGNOSTIC CODES:

00 - Test is successful  
Fault Codes  
03 - ID check  
07 - High speed read error  
09 - Hardware failure  
10 thru 69 - Refer to Structured Analysis Method (SAM)  
Termination Codes  
70 - Tape not loaded fault

FAULT CODE 13 - TAPE THREADED INCORRECTLY

Assumption: STU displays fault code 13 during a load operation as a result of not establishing tension within 10 seconds.

The most probable cause of this fault is that tape has been threaded with a long loop, or tape has not been tightly wrapped on take-up hub.

NOTE

Following any corrective action, perform a tape load operation.

010	<u>Y</u>	N	Execute CE test 43. Does pump fail to start?
020		<u>Y</u>	N Does air pressure lift tape off air bearings?
030			1 Replace filter.
040	<u>1</u>		2 Replace compressor assembly.
050			3 Replace regulator assembly.
060		<u>Y</u>	N Unthread tape. Push LOAD switch. Fault code 11 displayed?
070			1 Replace BOT/EOT assembly.
080		<u>2</u>	1 Replace servo-control PWA. (Refer to set-up tests in servo-control PWA removal/replacement procedure)
090		<u>3</u>	Replace power supply assembly.

SUB-FAULT CODES, FAULT CODE 13

---

- 01 Tension not detected on both sensors within 10 seconds
  - 02 Two coarse tachs not detected within 10 seconds
  - 03 Tension not detected within 2 seconds after seeing two coarse tachs
-

FAULT CODE 12

	A	B	C	
	<u>1</u>	<u>1</u>	<u>1</u>	
040			1	Replace servo-control PWA. (Refer to set-up tests in servo-control PWA removal/replacement procedure)
050			2	Replace supply motor/tach assembly.
060			3	Replace BOT/EOT sensor assembly.
070			<u>4</u>	Replace take-up motor/tach assembly. (Run set-up tests 37, 48)
080	<u>1</u>	<u>1</u>		Replace supply reel hub assembly.

SUB-FAULT CODES, FAULT CODE 12

01 Tension fault on load

---

FAULT CODE 15 - LOAD/UNLOAD ABORTED BY OPERATOR

Assumption: STU displays fault code 15 as a result of load or unload operation being aborted.

The most probable cause of this fault is that operator pressed RESET switch during load or unload operation.

NOTE

Following any corrective action, perform a tape load operation followed by an unload operation.

- 010 1 Replace operator panel assembly.
- 020 2 Replace servo-control PWA. (Refer to set-up tests in servo-control PWA removal/replacement procedure.)

SUB-FAULT CODES, FAULT CODE 15

- 01 RESET pressed during load
- 02 RESET pressed during unload

FAULT CODE 14 - BOT LOCATION

Assumption: The most probable cause of this fault is that tape leader is too long. ANSI Standard X3.39 specifies that BOT reflective marker should be placed from 14 feet to 18 feet from physical beginning of tape.

NOTE

Following any corrective action, perform a tape load operation followed by an unload operation.

- 010 1 Replace BOT/EOT sensor assembly.
- 020 2 Replace servo-control PWA. (Refer to set-up tests in servo-control PWA removal/replacement procedure.)

SUB-FAULT CODES, FAULT CODE 14

- 01 Tension fault. Loading. BOT not seen.
- 02 Absense of Tape. Loading. BOT not seen.
- 03 Did not get below lower tension limit within prescribed period during unload.



FAULT CODE 17 - RAN OFF END OF TAPE

Assumption: STU displays fault code 17 as a result of running off the physical end of tape.

The most probable cause of this fault is that the system continued issuing FORWARD READ/WRITE commands after EOT has been sensed. A possible cause is that the trailer is too short (ANSI Standard X3.39 specifies trailer should be longer than 25 feet).

NOTE

Following any corrective action, execute operator diagnostic test 01.

- |     |   |   |  |
|-----|---|---|--|
| 010 | Y | N | Load a known good tape and execute CE test 44.<br>Does tape stop within trailer?                       |
| 020 | 2 | 1 | Replace servo-control PWA. (Refer to set-up tests in servo-control PWA removal/replacement procedure.) |
| 030 | 1 | 2 | Replace formatter write PWA.   |

SUB-FAULT CODES, FAULT CODE 17

- |    |   |
|----|---|
| 01 | Absence of tape . Trailer . Forward           |
| 02 | Below lower tension limit . Trailer . Forward |
-

FAULT CODE 16 - DIAGNOSTIC TAPE IS  
WRITE PROTECTED

Assumption: STU displays fault code 16 on execution of a read/write diagnostic test with a write protected scratch tape.

The most probable cause of this fault is that the scratch tape in use does not have a write enable ring installed.

NOTE

Following any corrective action, execute operator diagnostic test 01.

- 010 1 Remove write enable sensor cover plate and ensure connector is correctly connected to sensor.
- 020 Y N Does write permit ring push reflective ring part of supply reel hub assembly in line with write enable sensor?
- 030 1 Replace supply reel hub assembly.
- 040 1 Replace file protect sensor assembly.
- 050 2 Replace servo-control PWA. (Refer to set-up tests in servo-control PWA removal/replacement procedure.)
- 060 3 Replace formatter write PWA.

SUB-FAULT CODES, FAULT CODE 16

- 00 Attempted to execute a read/write diagnostic with write-protected tape
- 01 Attempted to execute operator test 01 with write-protected tape

FAULT CODE 20 - FILE TENSION SENSOR

Assumption: STU displays fault code 20 as a result of a file tension fault.

NOTE

Following any corrective action, execute a tape load operation or operator diagnostic test 01.

010	<u>1</u>			Ensure that cable between supply air bearing assembly and servo-control PWA is correctly connected.
020	Y	N		Press CE switch. Sub-fault code 05?
030		Y	N	Sub-fault code 02 or 04?
040			Y	N Disconnect cable between supply air bearing assembly and servo-control PWA at servo-control PWA assembly. Try to load a tape. Fault code 20, sub-fault code 05?
050	<u>1</u>		<u>1</u>	Replace supply air bearing assembly. Reconnect cable.
060	<u>2</u>	<u>1</u>	<u>2</u>	<u>1</u> Replace servo-control PWA. Reconnect cable. (Refer to set-up tests in servo-control PWA removal/replacement procedure.)

SUB-FAULT CODES, FAULT CODE 20

00	Offset comparator is low with minimum offset
01	Offset comparator is high with maximum offset
02	2 oz. detected with no tension
04	Upper tension detected with no tension
05	Did not reach 2 oz. within 100 ms of takeup sensor detecting 2 oz. during load.

FAULT CODE 18 - TAPE ALREADY LOADED

Assumption: STU displays fault code 18 as a result of attempting to execute a diagnostic test which requires tape to be untensioned.

The most probable cause of this fault is that tape is already loaded while attempting to execute test that requires tape to be untensioned.

NOTE

Following any corrective action,  
execute operator diagnostic test 01.

010 1 Replace servo-control PWA. (Refer to set-up tests in  
servo-control PWA removal/replacement procedure.)

SUB-FAULT CODES, FAULT CODE 18

00 Attempted to execute operator test 1 with tape already  
loaded.

---

FAULT CODE 22 - UNABLE TO TENSION TAPE

Assumption: STU displays fault code 22 as a result of being unable to maintain tape tension during a tape load operation.

The most probable cause of this fault is that the tape being loaded has been subjected to extreme temperature or humidity changes. These tapes can sometimes be recognized by shaking the full reel and hearing the tape pack move relative to the reel. To continue using these tapes, the reel must be re-wrapped at the correct tension. At the time of reporting the fault, all the tape may have been removed from the supply reel. In this case, rewrap the tape onto the supply reel (to the BOT side of the EOT marker) and perform a normal load operation. If tape was not removed from the supply reel, perform a TEST LOAD operation to remove tape.

NOTE

Perform tape load operation following any corrective action. During load operation, observe the file reel for pack slip.

010	1				Clean read-write head, tape cleaner, and air bearings.
020	2				Unload tape by pressing UNLOAD switch while tape is not at BOT. Remove reel and clean hub pads.
030	Y	N			Inspect hub latching mechanism for breakage or excessive wear. Any problem found?
040		Y	N		Mount reel and latch the hub. While holding hub, can reel be easily rotated in either direction?
050			Y	N	Press CE Switch. Sub-fault code 03 or 04 or 05?
060			Y	N	Execute diagnostic test 02 with tape threaded. Termination code 70?
	2	2	2	2	2
	A	B	C	D	E

FAULT CODE 21 - TAKE-UP TENSION SENSOR

Assumption: STU displays fault code 21 as a result of a take-up tension fault.

NOTE

Following any corrective action, execute a tape load operation or operator diagnostic test 01.

010	<u>1</u>			Ensure that cable between take-up air bearing assembly and servo-control PWA is correctly connected.
020	<u>Y</u>	<u>N</u>		Press CE switch. Sub-fault code 05?
030		<u>Y</u>	<u>N</u>	Sub-fault code 02 or 03 or 04?
040			<u>Y</u>	<u>N</u> Disconnect cable between take-up air bearing assembly and servo-control PWA at servo-control PWA assembly. Try to load a tape. Fault code 21, sub-fault code 05?
050	<u>1</u>		<u>1</u>	Replace take-up air bearing assembly. Reconnect cable.
060	<u>2</u>	<u>1</u>	<u>2</u>	<u>1</u> Replace servo-control PWA. Reconnect cable. (Refer to set-up tests in servo-control PWA removal/replacement procedure.)

SUB-FAULT CODES, FAULT CODE 21

00	Offset comparator is low with minimum offset
01	Offset comparator is high with maximum offset
02	2 oz detected with no tension
03	9 oz. detected with no tension
04	Upper tension detected with no tension
05	Did not reach 2 oz. within 100 ms of file sensor detecting 2 oz during load

**CE TEST 25: 25 IPS STREAMING WRITE TO EOT IN GCR MODE**

**TEST REQUIREMENT:** A write-enabled scratch tape must be loaded.

**TEST DESCRIPTION:** Test 25 rewinds the tape and writes 2K byte records, incrementing data pattern to EOT at 25 ips streaming mode. On detection of EOT, it rewinds and positions at BOT. If a write error occurs, the unit performs BACKSPACE, ERASE, and attempts to write again. If more than 5 consecutive erases are required, the test terminates with a write fault. If 32 erases are required in one complete pass, the test terminates with a write fault. All functional checks are active throughout test.

**TEST OPTIONS:** 00 = Halt if read or write errors exceed limits specified, halt on completion of test (Default option).  
 01 = Loop on test, halt if read or write errors exceed limit specified on any given pass.  
 02 = Loop on test, bypass read or write error halts.

**NOTE**

Option of halting or bypassing errors only exists for read/write type errors; all other errors will cause test to halt, with appropriate fault code displayed, regardless of the option selected.

**TEST SEQUENCE:**

- a. REWIND to BOT (this function is not performed if 02 option is selected).
- b. WRITE 2K byte records at 25 ips streaming to EOT.
- c. REWIND to BOT.

**POSSIBLE DIAGNOSTIC CODES:**

00 - Test is successful  
 Fault Codes  
 03 - ID check  
 04 - Low speed write error  
 08 - Noise detected while erasing  
 09 - Hardware failure  
 10 thru 69 - Refer to Structured Analysis Method (SAM)  
 Termination Codes  
 70 - Tape not loaded fault

CE TEST 26: 75 IPS STREAMING WRITE TO EOT IN GCR MODE

TEST REQUIREMENT: A write-enabled scratch tape must be loaded.

TEST DESCRIPTION: Test 26 rewinds the tape and writes 2K byte records, incrementing data patterns to EOT at 75 ips in streaming mode. On detection of EOT, it rewinds and positions at BOT. If a write error occurs, the unit performs BACKSPACE, ERASE, and attempts to write again. If more than 5 consecutive erases are required, the test terminates with a write fault. If 32 erases are required in one complete pass, the test terminates with a write fault. All functional checks are active throughout test.

TEST OPTIONS: 00 = Halt if read or write errors exceed limits specified, halt on completion of test (Default option).  
 01 = Loop on test, halt if read or write errors exceed limit specified on any given pass.  
 02 = Loop on test, bypass read or write error halts.

## NOTE

Option of halting or bypassing errors only exists for read/write type errors; all other errors will cause test to halt, with appropriate fault code displayed, regardless of the option selected.

## TEST SEQUENCE:

- a. REWIND to BOT (this function is not performed if 02 option is selected).
- b. WRITE 2K byte records at 75 ips streaming to EOT.
- c. REWIND to BOT.

## POSSIBLE DIAGNOSTIC CODES:

00 - Test is successful  
 Fault Codes  
 03 - ID check  
 06 - High speed write error  
 08 - Noise detected while erasing  
 09 - Hardware failure  
 10 thru 69 - Refer to Structured Analysis Method (SAM)  
 Termination Codes  
 70 - Tape not loaded fault



**CE TEST 28: PERFORM COMMAND STACK AT 25 IPS START/STOP**

- TEST REQUIREMENT:**
- a. If a write-type operation is desired, a write-enabled scratch tape must be loaded.
  - b. If a read-type operation is desired, a pre-recorded tape must be loaded.

**TEST DESCRIPTION:** Test 28 performs the three-level command stack entered by Test 97. If option 01 is entered, the stack will be repeated until EOT or BOT is detected. If write operation is being performed upon an error, a BACKSPACE, ERASE, and REWRITE is performed. If a read operation is being performed, any uncorrectable read error causes the test to fail with a read fault. All functional checks are active throughout the test.

- TEST OPTIONS:**
- 00 = Halt if read or write errors exceed limits specified, halt on completion of test (Default option).
  - 01 = Loop on test, halt if read or write errors exceed limit specified on any given pass.
  - 02 = Loop on test, bypass read or write error halts.

**NOTE**

Option of halting or bypassing errors only exists for read/write type errors; all other errors will cause test to halt, with appropriate fault code displayed, regardless of the option selected.

**POSSIBLE DIAGNOSTIC CODES:**

- 00 - Test is successful
- Fault Codes
- 03 - ID check
- 04 - Low speed write error
- 05 - Low speed read error
- 08 - Noise detected while erasing
- 09 - Hardware failure
- 10 thru 69 - Refer to Structured Analysis Method (SAM)
- Termination Codes
- 70 - Tape not loaded fault

CE TEST 29: PERFORM COMMAND STACK AT 75 IPS THRASHING

- TEST REQUIREMENT:
- a. If a write-type operation is desired, a write-enabled scratch tape must be loaded.
  - b. If read-type operation is desired, a pre-recorded tape must be loaded.

TEST DESCRIPTION: Test 29 performs the three-level command stack entered by test 97. If option 01 is entered, the stack will be repeated until EOT or BOT is detected. If write operation is being performed upon an error, a backspace, erase, and rewrite operation is performed. If read operation is being performed, any uncorrectable read error will cause the test to fail with a read fault. All functional checks are active throughout the test.

- TEST OPTIONS:
- 00 = Halt if read or write errors exceed limits specified, halt on completion of test (Default option).
  - 01 = Loop on test, halt if read or write errors exceed limit specified on any given pass.
  - 02 = Loop on test, bypass read or write error halts.

## NOTE

Option of halting or bypassing errors only exists for read/write type errors; all other errors will cause test to halt, with appropriate fault code displayed, regardless of the option selected.

## POSSIBLE DIAGNOSTIC CODES:

- 00 - Test is successful
- Fault Codes
- 03 - ID check
- 06 - High speed write error
- 07 - High speed read error
- 08 - Noise detected while erasing
- 09 - Hardware failure
- 10 thru 69 - Refer to Structured Analysis Method (SAM)
- Termination Codes
- 70 - Tape not loaded fault

CE TEST 30: CHECK READ AMPLITUDES AT 25 AND 75 IPS  
WITH TOLERANCE OF + 0.8 VOLTS

TEST REQUIREMENT: Tape must be loaded and not write protected, and must not be near EOT.

TEST DESCRIPTION: Test 30 checks that read amplitudes at 25 and 75 ips are  $1.5 \pm 0.8$  volts. For 25 ips, the minimum read amplifier gain value is determined for each track, such that the peak-to-peak voltage at the analog test point is 1.5 volts. This generates an envelope signal for that track. If, at the end of the test, an envelope is not detected for any track, a fault is reported. The gain determined for each track is compared to corresponding gain value stored in the back-up memory (determined by test 31). If the difference for any track is such, that it causes an amplitude difference of 0.8 volts, a fault is reported. All CE options are available for the test.

The same operation is carried out for 75 ips.

TEST OPTIONS:

- 00 = Halt if read or write errors exceed limits specified, halt on completion of test (Default option).
- 01 = Loop on test, halt if read or write errors exceed limit specified on any given pass.
- 02 = Loop on test, bypass read or write error halts.

NOTE

Option of halting or bypassing errors only exists for read/write type errors; all other errors will cause test to halt, with appropriate fault code displayed, regardless of the option selected.

## CE TEST 30: (Cont'd)

## TEST SEQUENCE:

- a. Check if the operator door is closed, tape is not write protected, tape is loaded and not at EOT.
- b. Calculate the minimum read gain values for all tracks for 25 ips as described.
- c. Display fault code 01 if an envelope is not detected in track at the end of the test.
- d. Display fault code 02 if the difference in gain, between that determined and the corresponding value stored in the back-up memory for any track, is such that it causes an amplitude difference of 0.8 volts.
- e. Execute steps b, c, and d for 75 ips.
- f. Display termination code 00 if complete test is successful.

## POSSIBLE DIAGNOSTIC CODES:

00 - Test is successful

Fault Codes

01 - EGC envelope fault

02 - EGC wear tolerance fault

10 thru 69 - Refer to Structured Analysis Method (SAM) (SAM)

Termination Codes

70 - Tape not loaded fault

72 - Tape write protected fault

77 - EOT on EGC fault

## NOTE

CE Test 30 is a part of operator test 1.

CE TEST 31: SET UP AND CHECK READ AMPLITUDES  
AT 25 AND 75 IPS

TEST REQUIREMENT: Execute this test with a 3M777 or equivalent tape. Tape must be loaded and not write protected, and must not be near EOT. Jumper on the servo-control PWA back-up memory must be in 1-2 position. After completing the test, replace the jumper on the servo-control PWA back-up memory from the 1-2 position to the 2-3 position before powering down the STU.

TEST DESCRIPTION: Test 31 sets up and checks read amplitudes at 25 and 75 ips. At 25 ips, it determines the minimum gain value for each track, in the same manner as described in test 30, and stores them in the back-up memory. It again determines the minimum gain value for each track and compares it to the previously stored value. If the difference in gain between the two values for any track is such that it causes an amplitude difference of 0.1 volts, the test is repeated. Also, if any fault is detected while determining the minimum gain values, the test is repeated. If, after 5 attempts, the operation is not successful, a fault is reported.

The same operation is carried out at 75 ips.

TEST OPTIONS: None. (Loop-on-test option is not permitted with this test.)

TEST SEQUENCE:

- a. Check if the operator door is closed, tape is not write protected, tape is loaded, and tape is not at EOT.
- b. Determine the minimum gain values for 25 ips and store them in the back-up memory. Report a fault if the jumper on the servo-control PWA back-up memory is not in the 1-2 position.
- c. Determine the minimum gain values for 25 ips and compare them with the previously stored values. If, for any track, the difference is such that it causes an amplitude difference greater than 0.1 volts, the test is repeated.

## CE TEST 31: (Cont'd)

- d. If, while determining the minimum gain values in steps b and c, a fault is detected, the test is repeated.
- e. If, after five tries, the test is still not successful, terminate the test with termination code 78.
- f. Execute steps b, c, and d for 75 ips. If test is not successful after five tries, display termination code 79.
- g. Display termination code 00 if complete test is successful.

## POSSIBLE DIAGNOSTIC CODES:

00 - Test is successful

## Fault Codes

10 thru 69 - Refer to Structured Analysis Method (SAM)

## Termination Codes

70 - Tape not loaded fault

72 - Tape write protected fault

74 - Back-up memory not enabled

77 - EOT on EGC fault

78 - EGC low speed set-up failure \*

79 - EGC high speed set-up failure \*

80 - EGC low speed GCR set-up failure \*

81 - EGC high speed GCR set-up failure \*

99 - Attempt to loop on test

\* Run test 01 to determine source of failure.

CE TEST 32: CHECK READ AMPLITUDES AT 25 AND 75 IPS

TEST REQUIREMENT: Tape must be loaded and pre-written with all 1's, and must not be near EOT.

TEST DESCRIPTION: Test 32 checks that read amplitudes at 25 and 75 ips are  $1.5 \pm 0.3$  volts, with pre-written tape of all 1's. This test is similar to test 30 except that it requires pre-written tape and the tolerance value is  $\pm 0.3$  volts instead of 0.8 volts. All CE options are available for the test.

TEST OPTIONS:

- 00 = Halt if read or write errors exceed limits specified, halt on completion of test (Default option).
- 01 = Loop on test, halt if read or write errors exceed limit specified on any given pass.
- 02 = Loop on test, bypass read or write error halts.

## NOTE

Option of halting or bypassing errors exists only for read/write type errors; all other errors cause test to halt and display appropriate fault code regardless of the option selected.

## POSSIBLE DIAGNOSTIC CODES:

- 00 - Test is successful
- Fault Codes
- 01 - EGC envelope fault
- 02 - EGC wear tolerance fault
- 10 thru 69 - Refer to Structured Analysis Method (SAM)
- Termination Codes
- 70 - Tape not loaded fault
- 77 - EOT on EGC fault

CE TEST 33: SET UP READ AMPLITUDES AT 25 IPS

TEST REQUIREMENT: Tape must be loaded and not write protected, and must not be near EOT. Jumper on the servo-control PWA back-up memory must be in the 1-2 position. After completing the test, replace the jumper on the servo-control PWA back-up memory from the 1-2 position to the 2-3 position before powering down the STU.

TEST DESCRIPTION: Test 33 determines and stores the read gains at 25 ips. This test is similar to Test 31 except it is done only at 25 ips, and whenever a fault is detected, the test is terminated and the fault is reported.

TEST OPTIONS: None. (Loop-on-test option is not permitted with this test.)

## POSSIBLE DIAGNOSTIC CODES:

00 - Test is successful

Fault Codes

01 - EGC envelope fault

10 thru 69 - Refer to Structured Analysis Method (SAM)

Termination Codes

70 - Tape not loaded fault

72 - Tape write protected fault

73, 74 - Back up memory not write enabled

75, 76 - Bad back up memory

77 - EOT on EGC fault

99 - Attempt to loop on test



**CE TEST 34: SET UP READ AMPLITUDES AT 75 IPS**

**TEST REQUIREMENT:** Tape must be loaded and not write protected, and must not be near EOT. Jumper on the servo-control PWA back-up memory must be in the 1-2 position. After completing the test, replace the jumper on the servo-control PWA back-up memory from the 1-2 position to the 2-3 position before powering down the STU.

**TEST DESCRIPTION:** Test 34 determines and stores the read gains at 75 ips. This test is similar to test 31 except it is done only at 75 ips, and whenever a fault is detected, the test is terminated and the fault is reported.

**TEST OPTIONS:** None. (Loop on test is not permitted with this test.)

**POSSIBLE DIAGNOSTIC CODES:**

00 - Test is successful

**Fault Codes**

01 - EGC envelope fault

10 thru 69 - Refer to Structured Analysis Method (SAM)

**Termination Codes**

70 - Tape not loaded fault

72 - Tape write protected fault

73, 74 - Back up memory not write enabled

75; 76 - Bad back up memory

77 - EOT on EGC fault

99 - Attempt to loop on test

CE TEST 37: SET UP VELOCITY CORRECTION MULTIPLIER

TEST REQUIREMENT: Tape must not be threaded. Jumper on the servo-control PWA back-up memory must be in the 1-2 position. After completing the test, replace the jumpers on the servo-control PWA back-up memory from the 1-2 position to the 2-3 position before powering down the STU.

TEST DESCRIPTION: Test 37 sets up the velocity correction multiplier for the velocity DAC.

## NOTE

Execution of test 37 affects tests 48, 50, 81 and 84 as follows:

Test 48 (Enabled Compressor Power-Down Timer) - Disabled.

Test 50 (Enable Power-On Auto-Load) - Disabled.

Test 81 (Select Early EOT Point) - Set at 50 feet.

Test 84 (Select/Examine STU Options) - All option bits cleared to 0 (buffered enhanced I/F only).

Before executing test 37, make a record of the status of tests 48, 50, 81 and 84 so that you can restore the original option selection.

TEST OPTIONS: None. (Loop on test is not permitted with this test.)

## TEST SEQUENCE:

- a. Check if the operator door is closed and tape is absent.
- b. Move take-up reel forward at about 19 ips velocity (for BOT radius).
- c. Calculate velocity correction multiplier for velocity DAC.
- d. Display termination code 93 if velocity correction multiplier is out of range.

CE TEST 37: (Cont'd)

- e. Stop take-up reel and store velocity correction multiplier in back-up memory.
- f. Display termination code 00 if complete test is successful.

POSSIBLE DIAGNOSTIC CODES:

00 - Test is successful

Fault Codes

10 thru 69 - Refer to Structured Analysis Method (SAM)

Termination Codes

73, 74 - Back up memory not write enabled

75, 76 - Bad back up memory

93 - Velocity correction multiplier factor out of range

94 - Tape threaded fault

99 - Attempt to loop on test



CE TEST 38: PULSE FILE REEL AT 8 OUNCES

TEST REQUIREMENT: Tape (10.5 inch reel) must be threaded close to BOT without any loop.

TEST DESCRIPTION: This test puts the take-up reel in stoplock. It pulses the file reel in the reverse direction to maintain approximately 8 ounces of tension. Manual intervention is required to terminate the test.

TEST OPTIONS: None.

## TEST SEQUENCE:

- a. Check if the operator door is closed and tape is present.
- b. Put take-up reel in Stoplock.
- c. Turn on pump.
- d. Pulse the file reel.

## POSSIBLE DIAGNOSTIC CODES:

## Fault Codes

10 thru 69 - Refer to Structured Analysis Method (SAM)

## Termination Codes

71 - Tape loaded fault

CE TEST 39: WRITE OPTION PATTERN IN PE MODE  
TO EOT AT 25 IPS

TEST REQUIREMENT: Tape must be loaded and not write protected.

TEST DESCRIPTION: Test 39 writes tape with option pattern in PE mode at 25 ips to EOT. At EOT, tape is rewound to BOT. Pattern options are available for the test.

TEST OPTIONS: 00 = All ones pattern  
01 = One-half frequency pattern

TEST SEQUENCE:

- a. Check if the operator door is closed.
- b. Check if tape is loaded and not write protected.
- c. Write option pattern in PE mode to EOT at 25 ips.
- d. Rewind to BOT.
- e. Repeat test from step c.

POSSIBLE DIAGNOSTIC CODES:

Fault Codes

10 thru 69 - Refer to Structured Analysis Method (SAM)

Termination Codes

70 - Tape not loaded fault

72 - Tape write protected fault

CE TEST 40: WRITE OPTION PATTERN IN PE MODE  
TO EOT AT 75 IPS

TEST REQUIREMENT: Tape must be loaded and not write protected.

TEST DESCRIPTION: Test 40 writes tape with option pattern in PE mode at 75 ips to EOT. At EOT, it is rewound to BOT. Pattern options are available for the test.

TEST OPTIONS: 00 = All ones pattern  
01 = One-half frequency pattern

TEST SEQUENCE:

- a. Check if the operator door is closed.
- b. Check if tape is loaded and not write protected.
- c. Write option pattern in PE mode to EOT at 75 ips.
- d. Rewind to BOT.
- e. Repeat test from step c.

POSSIBLE DIAGNOSTIC CODES:

Fault Codes

10 thru 69 - Refer to Structured Analysis Method (SAM)

Termination Codes

70 - Tape not loaded fault

72 - Tape write protected fault

CE TEST 41: STOPLOCK TAKE-UP REEL

TEST REQUIREMENT: Tape must not be loaded.

TEST DESCRIPTION: Test 41 checks the stoplock mode of the take-up reel servo. Manual intervention is required to terminate the test.

TEST OPTIONS: None.

TEST SEQUENCE:

- a. Check if the operator door is closed.
- b. Put take-up reel servo in stoplock mode.

POSSIBLE DIAGNOSTIC CODES:

Fault Codes

10 thru 69 - Refer to Structured Analysis Method (SAM)

Termination Codes

71 - Tape loaded fault



CE TEST 42: ENABLE TENSION SERVO

TEST REQUIREMENT: Tape must be threaded. Tape slack must be removed to allow file servo to be enabled.

TEST DESCRIPTION: Test 42 allows tape tension to be checked via the tension servo. It produces 8 ounces of tension by enabling tension servo.

TEST OPTIONS: None.

## TEST SEQUENCE:

- a. Check if the operator door is closed. If tape is absent, go to step d.
- b. Take up slack in tape by slowly moving take-up reel in reverse direction until tension is reached.
- c. Enable tension servo operation at 8 ounces.
- d. If tape is pulled out of tape path, display termination code 00.

## POSSIBLE DIAGNOSTIC CODES:

00 - Test is successful

Fault Codes

10 thru 69 - Refer to Structured Analysis Method (SAM)

Termination Codes

71 - Tape loaded fault

CE TEST 43: TURN ON PUMP

TEST REQUIREMENT: Tape must not be loaded.

TEST DESCRIPTION: Test 43 turns on the pump. Manual intervention is required to terminate test.

TEST OPTIONS: None.

TEST SEQUENCE:

- a. Check if the operator door is closed and tape is not loaded.
- b. Turn on pump.

POSSIBLE DIAGNOSTIC CODES:

Fault Codes

10 thru 69 - Refer to Structured Analysis Method (SAM)

Termination Codes

71 - Tape loaded fault

CE TEST 44: FAST FORWARD TO EOT

TEST REQUIREMENT: Tape must be loaded.

TEST DESCRIPTION: Test 44 moves tape forward at rewind speed to EOT.

TEST OPTIONS: None.

TEST SEQUENCE:

- a. Check if the operator door is closed and tape is loaded.
- b. Gradually increase speed and then maintain rewind speed.
- c. Wait until EOT is detected.
- d. Stop motion and display termination code 00.

POSSIBLE DIAGNOSTIC CODES:

00 - Test is successful

Fault Codes

10 thru 69 - Refer to Structured Analysis Method (SAM)

Termination Codes

70 - Tape not loaded fault

CE TEST 45: REFRESH DAC SCOPE LOOP

TEST REQUIREMENT: Tape must not be loaded.

TEST DESCRIPTION: Test 45 exercises the refresh DAC on the servo-control PWA. If refresh DAC is operational, a triangle waveform of 35 ms period will be observed on the scope. Manual termination is required to terminate the test.

TEST OPTIONS: None.

## TEST SEQUENCE:

- a. Check if the operator door is closed.
- b. Output zero voltage at TP 14 through refresh DAC, and increase it by 20 mv at every 60 microseconds (approximate) until it reaches 5 volts.
- c. Decrease output at refresh DAC by 20 mv at every 60 microseconds (approximate) until it reaches 0 volt.
- d. Go to step b.

## POSSIBLE DIAGNOSTIC CODES:

## Fault Codes

10 thru 69 - Refer to Structured Analysis Method (SAM)

## Termination Codes

71 - Tape loaded fault

CE TEST 46: VELOCITY DAC SCOPE LOOP

TEST REQUIREMENT: Tape must not be loaded.

TEST DESCRIPTION: Test 46 exercises the velocity DAC on the servo-control PWA. If velocity DAC is operational, a triangle waveform of 35 ms period will be observed on the scope. Manual termination is required to terminate the test.

TEST OPTIONS: None.

## TEST SEQUENCE:

- a. Check if the operator door is closed.
- b. Output zero voltage at velocity DAC, and increase it by 20 mv at every 60 microseconds (approximate) until it reaches 6.9 volts.
- c. Decrease output at velocity DAC by 20 mv at every 60 microseconds (approximate) until it reaches 0 volt.
- d. Go to step b.

## POSSIBLE DIAGNOSTIC CODES:

## Fault Codes

10 thru 69 - Refer to Structured Analysis Method (SAM)

## Termination Codes

71 - Tape loaded fault

CE TEST 47: SERVO-CONTROL MICROPROCESSOR  
OUTPUTS SCOPE LOOP

TEST REQUIREMENT: Tape must not be present.

TEST DESCRIPTION: Test 47 generates a pulse of 50 microseconds every 5 ms on each of the addressable outputs of the servo-control PWA. Manual intervention is required to terminate the test.

TEST OPTIONS: None.

TEST SEQUENCE:

- a. Check if the operator door is closed and tape is not present.
- b. Generate a 50 microsecond pulse every 5 ms on each of the addressable outputs of servo-control microprocessor.

POSSIBLE DIAGNOSTIC CODES:

Fault Codes

10 thru 69 - Refer to Structured Analysis Method (SAM)

Termination Codes

94 - Tape present fault

CE TEST 48: ENABLE COMPRESSOR POWER-DOWN TIMER

TEST REQUIREMENT: Tape must be unloaded. Jumper W1 on backup memory (on servo-control PWA) must be in the 1-2 (STORE ENABLE) position. After completing the test return jumper W1 to the 2-3 (STORE DISABLE) position before powering off the transport.

TEST DESCRIPTION: Test 48 sets up the compressor power-down timer for one minute if no tape motion has occurred.

TEST OPTIONS: None.

## POSSIBLE DIAGNOSTIC CODES:

00 - Test is successful  
Termination Codes  
73,74 - Backup memory is not store enabled  
75,76 - Bad backup memory  
94 - Tape present fault  
99 - Illegal remote test

## NOTE

To disable compressor power-down timer,  
run CE test 37.

CE TEST 50: ENABLE POWER-ON AUTO LOAD

TEST REQUIREMENT: Tape must be unloaded. Jumper W1 on backup memory (on servo-control PWA at location D23) must be in the 1-2 (STORE ENABLE) position. After completing the test return jumper W1 to the 2-3 (STORE DISABLE) position before powering off the transport.

DO NOT USE TEST 50 on units with buffered Pertec enhanced or buffered STC enhanced interface PWA's. Auto Load feature will not operate. Use Test 84 to enable Auto Load feature.

TEST DESCRIPTION: Test 50 enables the automatic loading of a properly threaded reel of tape after the drive successfully completes the power on health checks.

TEST OPTIONS: None.

## POSSIBLE DIAGNOSTIC CODES:

00 - Test is successful  
Termination Codes  
71 - Tape loaded fault  
73,74 - Backup memory is not store enabled  
75,76 - Bad backup memory  
99 - Illegal remote test

## NOTE

To disable the power-on auto load, run CE Test 37.



CE TEST 52: WRITE OPTION PATTERN IN GCR MODE  
TO EOT AT 25 IPS

TEST REQUIREMENT: Tape must be loaded and not write protected.

TEST DESCRIPTION: Test 52 writes tape with option pattern in GCR mode at 25 ips to EOT. At EOT, tape is rewound to BOT. Pattern options are available for the test.

TEST OPTIONS:       00 = All ones pattern  
                      01 = One-half frequency pattern  
                      02 = One-third frequency pattern

TEST SEQUENCE:

- a. Check if the operator door is closed.
- b. Check if tape is loaded and not write protected.
- c. WRITE option pattern in GCR mode to EOT at 25 ips.
- d. REWIND to BOT.
- e. Repeat test from step c.

POSSIBLE DIAGNOSTIC CODES:

Fault Codes

10 thru 69 - Refer to Structured Analysis Method (SAM)

Termination Codes

70 - Tape not loaded fault

72 - Tape write protected fault

CE TEST 53: WRITE OPTION PATTERN IN GCR MODE  
TO EOT AT 75 IPS

TEST REQUIREMENT: Tape must be loaded and not write protected.

TEST DESCRIPTION: Test 53 writes tape with option pattern in GCR mode at 75 ips to EOT. At EOT, it is rewound to BOT. Pattern options are available for the test.

TEST OPTIONS: 00 = All ones pattern  
01 = One-half frequency pattern  
02 = One-third frequency pattern

TEST SEQUENCE:

- a. Check if the operator door is closed.
- b. Check if tape is loaded and not write protected.
- c. WRITE option pattern in GCR mode to EOT at 75 ips.
- d. REWIND to BOT.
- e. Repeat test from step c.

POSSIBLE DIAGNOSTIC CODES:

Fault Codes

10.thru 69 - Refer to Structured Analysis Method (SAM)

Termination Codes

70 - Tape not loaded fault

72 - Tape write protected fault

CE TEST 54: CHANGE/EXAMINE WRITE CURRENT VALUES

## NOTE

Use this test to change/examine write current values only if a write current label is attached to the magnetic head. If there is no write current label attached to the magnetic head, use test 64.

- TEST REQUIREMENT:
- a. To change any of the write current values, move W1 jumper on Servo-Control PWA to position 1-2.
  - b. To examine (not change) write current value, no setup is necessary.

TEST DESCRIPTION: CE test 54 allows the changing or examining of the four write current values currently stored in backup memory.

TEST OPTIONS: None.

## TEST SEQUENCE:

- a. Enter CE test 54 and press EXEC switch.
- b. The display now shows the first write current value currently stored in backup memory (see figure 6-5 for hex value of symbols shown on display). Using the STEP switch, enter the first value from the read/write head tag and press EXEC switch. The first value has been entered and the display now shows the second write current value currently stored in backup memory. Enter the second value from the read/write head tag and press EXEC switch. Continue until all four write current values are entered.
- c. Press RESET switch.
- d. Verify the proper entering the new write current values by re-running CE test 54. If displayed value is correct, press EXEC switch to display the next value; otherwise, enter new value and press EXEC switch.
- e. Press RESET switch.

## CE TEST 54: (Cont'd)

## POSSIBLE DIAGNOSTIC CODES:

00 - Test is successful

Fault Codes

10 thru 69 - Refer to Structured Analysis Method (SAM)

Termination Codes

73, 74 - Backup memory jumper (W1) not in the 1-2 position

75, 76 - Bad backup memory

## NOTE

If jumper W1 was moved to the 1-2 position to allow changing of the write current values, return W1 to the 2-3 position before powering down transport.





SYMBOL	HEX VALUE	SYMBOL	HEX VALUE
	= A		= D
	= B		= E
	= C	BLANK	= F

Figure 6-5. Test 54 Hex Symbols

CE TEST 55: DRIVE INTERNAL DIAGNOSTIC

TEST REQUIREMENT: A tape must not be loaded.

TEST DESCRIPTION: Test 55 checks out the internal hardware of the drive.

TEST OPTIONS:

- 00 = Halt if read or write errors exceed limits specified, halt on completion of test (Default option).
- 01 = Loop on test, halt if read or write errors exceed limit specified on any given pass.
- 02 = Loop on test, bypass read or write error halts.

## NOTE

Option of halting or bypassing errors applies only to read/write type errors; all other errors cause test to halt, with appropriate fault code displayed, regardless of the option selected.

## TEST SEQUENCE:

- a. Check if the tape is not loaded.
- b. Check the drive functional PROM checksum.
- c. Check the drive diagnostic PROM checksum.
- d. Check the programmable timer #1.
- e. Check the programmable timer #2.

## POSSIBLE DIAGNOSTIC CODES:

00 - Test is successful

Fault Codes

10 thru 69 - Refer to Structured Analysis Method (SAM)

CE TEST 56: FORMATTER INTERNAL DIAGNOSTIC

TEST REQUIREMENT: None.

TEST DESCRIPTION: Test 56 checks out the internal hardware of the formatter. It does not check adapter interface or device interface hardware.

TEST OPTIONS: 00 = Halt if read or write errors exceed limits specified, halt on completion of test (Default option).  
01 = Loop on test, halt if read or write errors exceed limit specified on any given pass.  
02 = Loop on test, bypass read or write error halts.

## NOTE

Option of halting or bypassing errors applies only to read/write type errors; all other errors cause test to halt, with appropriate fault code displayed, regardless of the option selected.

## TEST SEQUENCE:

- a. Check out write hardware.
- b. Check out read/write interface hardware.
- c. Check out read hardware.
- d. Check out hardware used to write or read a data block.
- e. Check out VFOs for both speeds and densities.

## | POSSIBLE DIAGNOSTIC CODES:

00 - Test is successful

## Fault Codes

- 56 - Formatter/Drive communication fault
- 62 - Formatter write board health check fault
- 63 - Formatter read/write interface health check fault
- 64 - Formatter read PWA health check fault in data loopback
- 65 - Formatter read PWA health check fault

CE TEST 57: INTERFACE INTERNAL DIAGNOSTIC

TEST REQUIREMENT: None.

TEST DESCRIPTION: Test 57 checks out the internal hardware of the interface PWA. It does not check the interface between itself and the formatter.

TEST OPTIONS: 00 = Halt if read or write errors exceed limits specified, halt on completion of test (Default option).  
01 = Loop on test, halt if read or write errors exceed limit specified on any given pass.  
02 = Loop on test, bypass read or write error halts.

## NOTE

Option of halting or bypassing errors applies only to read/write type errors; all other errors cause test to halt, with appropriate fault code displayed, regardless of the option selected.

Wait at least 20 seconds after test 57 is over before placing the STU on-line.

## TEST SEQUENCE:

- a. Check the PROM checksum.
- b. Check out internal hardware.

## POSSIBLE DIAGNOSTIC CODES:

- 00 - Test is successful  
Fault Codes  
56 - Formatter/Drive communication fault  
59 - Interface Adapter fault (SCSI interface only)  
66 - Formatter/Interface communication fault  
67 - Interface health check fault  
68 - Interface checksum fault

CE TEST 58: LOOP WRITE-TO-READ THRU DRIVE  
INTERFACE

TEST REQUIREMENT: None.

TEST DESCRIPTION: Test 58 loops data through the drive interface. The formatter writes 2K byte records, incrementing data patterns for each speed and density.

TEST OPTIONS: 00 = Halt if read or write errors exceed limits specified, halt on completion of test (default option).  
01 = Loop on test, halt if read or write errors exceed limit specified on any given pass.  
02 = Loop on test, bypass read or write error halts.

## NOTE

Option of halting or bypassing errors applies only to read/write type errors; all other errors cause test to halt, with appropriate fault code displayed, regardless of the option selected.

## TEST SEQUENCE:

- a. WRITE 10 records in low speed PE mode.
- b. WRITE 10 records in high speed PE mode.
- c. WRITE 10 records in low speed GCR mode.
- d. WRITE 10 records in high speed GCR mode.

## POSSIBLE DIAGNOSTIC CODES:

- 00 - Test is successful
- Fault Codes
- 04 - Low speed write error
- 06 - High speed write error
- 09 - Hardware failure
- 56 - Formatter/Drive communication fault



CE TEST 59: LOOP WRITE-TO-READ THRU READ/WRITE

TEST REQUIREMENT: Tape must be unthreaded.

TEST DESCRIPTION: Test 59 loops data through the read/write in the drive. The formatter writes 2K byte records, incrementing data patterns for low speed GCR mode only.

TEST OPTIONS: 00 = Halt if read or write errors exceed limits specified, halt on completion of test (default option).  
01 = Loop on test, halt if read or write errors exceed limit specified on any given pass.  
02 = Loop on test, bypass read or write error halts.

## NOTE

Option of halting or bypassing errors applies only to read/write type errors; all other errors cause test to halt, with appropriate fault code displayed, regardless of the option selected.

## TEST SEQUENCE:

- a. WRITE 10 records in low speed GCR mode.

## POSSIBLE DIAGNOSTIC CODES:

00 - Test is successful  
Fault Codes  
04 - Low speed write error  
09 - Hardware failure  
56 - Formatter/Drive communication fault

**CE TEST 60: LOOP WRITE-TO-READ THRU FORMATTER**

**TEST REQUIREMENT:** None.

**TEST DESCRIPTION:** Test 60 loops data through the formatter. The formatter writes 2K byte records, incrementing data patterns for each speed and density.

**TEST OPTIONS:**

- 00 = Halt if read or write errors exceed limits specified, halt on completion of test (default option).
- 01 = Loop on test, halt if read or write errors exceed limit specified on any given pass.
- 02 = Loop on test, bypass read or write error halts.

**NOTE**

Option of halting or bypassing errors applies only to read/write type errors; all other errors cause test to halt, with appropriate fault code displayed, regardless of the option selected.

**TEST SEQUENCE:**

- a. WRITE 10 records in low speed PE mode.
- b. WRITE 10 records in high speed PE mode.
- c. WRITE 10 records in low speed GCR mode.
- d. WRITE 10 records in high speed GCR mode.

**POSSIBLE DIAGNOSTIC CODES:**

00 - Test is successful  
Fault Codes  
04 - Low speed write error  
06 - High speed write error  
09 - Hardware failure  
Termination Codes  
56 - Formatter/Drive communication fault

CE TEST 61: TAKE-UP MOTOR AND POWER AMP FULL  
CAPABILITY DETECTION TEST

TEST REQUIREMENT: Tape must not be threaded.

TEST DESCRIPTION: Test 61 checks out whether take-up motor performance is within range. It also checks out whether take-up section of the power amp is capable of delivering full current.

TEST OPTIONS: None.

TEST SEQUENCE:

- a. Check if the operator door is closed and tape is absent.
- b. Apply diagnostic lines to move take-up motor in forward direction from 0 to 75 ips, and measure time it requires to ramp-up. Stop take-up motor.
- c. Calculate motor constant from this data.
- d. If motor constant is within range, go to step e. If motor constant is out of range the first time, repeat steps b and c. Otherwise, display termination code 84.
- e. Apply full current to move take-up motor in forward direction from 0 to 75 ips, and measure time it requires to ramp-up. Stop take-up motor.
- f. If power amp is not capable of delivering full current in forward direction, flag a fault; otherwise, go to step h.
- g. If fault is the first time, repeat steps e and f, otherwise, display termination code 82.
- h. Apply full current to move take-up motor in reverse direction from 0 to 75 ips, and measure time it requires to ramp-up. Stop take-up motor.
- i. If power amp is not capable of delivering full current in reverse direction, flag a fault; otherwise, go to step k.
- j. If fault is the first time, repeat steps h and i, otherwise, display termination code 82.
- k. Display termination code 00 to indicate successful completion of test.

CE TEST 61: (Cont'd)

| POSSIBLE DIAGNOSTIC CODES:

00 - Test is successful

Fault Codes

10 thru 69 - Refer to Structured Analysis Method (SAM)

Termination Codes

82 - Take-Up power amp fault

84 - Take-up motor/tach fault

94 - Tape threaded fault

CE TEST 62: TAKE-UP FINE TACH FAULT DETECTION

TEST REQUIREMENT: Tape must not be threaded.

TEST DESCRIPTION: Test 62 checks that the distance between two consecutive quarter tachs (derived from fine line tachs at the take-up motor) is within tolerable limits.

TEST OPTIONS: None.

## TEST SEQUENCE:

- a. Check if the operator door is closed and tape is absent.
- b. Ramp up to 4 ips.
- c. Check if distance between two consecutive quarter tachs is within tolerable limits.
- d. If, after five tries, at least once, the distance between two consecutive quarter tachs is within limits, go to step f.
- e. Display termination code 96.
- f. Check that the distance between all consecutive quarter tachs is within tolerable limits.
- g. If distance between any two consecutive quarter tachs is not within limits, report fault, otherwise, go to step i.
- h. Repeat steps e and f. If the error is detected five times, display termination code 84.
- i. Display termination code 00 to indicate successful completion of test.

## POSSIBLE DIAGNOSTIC CODES:

00 - Test is successful  
Fault Codes  
10 thru 69 - Refer to Structured Analysis Method (SAM)  
Termination Codes  
84 - Take-Up motor/tach fault  
94 - Tape threaded fault  
95 - Formatter interrupt received while test in progress.  
96 - Servo loop fault

CE TEST 64: AUTO-WRITE CURRENT LEVEL ADJUSTMENT

## NOTE

If a write current label is attached to the magnetic head, use test 54 to change/examine write current levels. Do not use this test.

TEST REQUIREMENT: Execute this test with a 3M777 or equivalent tape (or the most frequently used tape at the site) with a minimum accumulation of 10 full reel passes on a transport. Discard a tape showing signs of oxide breakdown (identifiable by contamination of magnetic head).

Clean the magnetic head.

Load a qualified, write-enabled, 2400-foot reel of tape.

Move jumper W-1 on the servo-control PWA to the 1-2 position.

TEST DESCRIPTION: Test 64 determines the optimum write current level for all 9 tracks. The write current levels are determined for 25 ips PE, 25 ips GCR, 75 ips PE, and 75 ips GCR. The values are stored in backup memory.

TEST OPTIONS: None.

## TEST SEQUENCE:

- a. Enter test 64. Press EXECUTE switch.
- b. Test runs to completion.
- c. Execute test 31.
- d. Before turning power off, move jumper W-1 on the servo-control PWA to the 2-3 position.

CE TEST 64: (Cont'd)

POSSIBLE DIAGNOSTIC CODES:

00 - Test is successful

Fault Codes

01 - Read envelope fault

10 thru 69 - Refer to Structured Analysis Method (SAM)

Termination Codes

70 - Tape not loaded fault

72 - Tape write protected fault

73, 74 - Backup memory jumper (W-1 not in 1-2 position)

75, 76 - Bad backup memory

77 - Not enough tape to complete test

80 - PE 25 ips setup fault \*

81 - PE 75 ips setup fault \*

82 - GCR 25 ips setup fault \*

83 - GCR 75 ips setup fault \*

87 - Write currents inconsistent fault

88 - Optimized write current exceeds maximum

\* Run test 01 to determine source of failure.

CE TEST 80: RETAIN TAPE POSITION ON POWER-DOWN

TEST REQUIREMENT: Tape must be loaded and positioned at least 10 feet beyond BOT and at least 10 feet before EOT. Reels must not be moved after power-down.

TEST DESCRIPTION: Test 80 calculates and stores in memory the tape position values prior to power-down. On power-up, tape is returned to reference position.

## TEST SEQUENCE:

- a. Check if tape is loaded.
- b. Save tape radius and drive status information.
- c. Establish tape reference point for power-up.
- d. Remove power from take-up and supply motors.
- e. Disable all operator control panel switches except OFF.
- f. OFF switch is pressed. (The circuit breaker may be placed in the OFF (0) position and the ac power cord unplugged.)
- g. Drive is powered on.
- h. Tape is positioned at reference point within  $\pm$  3 inches.
- i. Drive may be placed ON-LINE.

## POSSIBLE DIAGNOSTIC CODES:

00 - Test is successful  
Fault Codes  
10 thru 69 - Refer to Structured Analysis Method (SAM)  
Termination Codes  
73 - Tape is positioned in leader or trailer  
75, 76 - Bad back-up memory  
78 - Tape too close to BOT



CE TEST 81: SELECT EARLY EOT POINT

TEST REQUIREMENT: Interface PWA must be buffered version or buffered enhanced version.

TEST DESCRIPTION: Test 81 selects the distance between early EOT and EOT marker. Default value is 50 feet. The host may elect to act on either early EOT or EOT.

TEST OPTIONS:

- 00 - 50 feet
- 01 - 100 feet
- 02 - 150 feet
- 03 - 200 feet
- 04 - 250 feet
- 05 - 300 feet
- 06 - 350 feet
- 07 - 400 feet
- 08 - 450 feet
- 09 - 500 feet
- 0A - 20 feet

## TEST SEQUENCE

- a. Store options selected in back-up memory.

## POSSIBLE DIAGNOSTIC CODES:

00 - Test is successful  
Fault Codes  
10 thru 69 - Refer to Structured Analysis Method (SAM)  
Termination Codes  
75, 76 - Bad back-up memory

CE TEST 84 (BPEI): SELECT/EXAMINE STU OPTIONS

NOTE

Test 84, buffered Pertec enhanced interface (BPEI) includes only the options available with buffered Pertec enhanced interface. For a description of the options available with the buffered STC enhanced interface, refer to the next test, Test 84 (BSTCEI).

TEST REQUIREMENT: Interface PWA must be buffered Pertec enhanced version. Tape must not be loaded.

TEST DESCRIPTION: Test 84 allows the examining or changing of STU options.

TEST OPTIONS: None.

TEST SEQUENCE

a. To examine options:

1. Enter CE test 84.
2. Press and hold EXECUTE switch. Display = 01 (byte 1).
3. Release EXECUTE switch. Display = value stored in byte 1.
4. Press and hold EXECUTE switch. Display = 02 (byte 2).
5. Release EXECUTE switch. Display = value stored in byte 2.

This sequence may be continued through byte 8. If no selections have been entered in a byte, display = 80 (most significant bit = 1, all others = 0).

b. To select or change options:

1. Enter CE test 84. Press and release EXECUTE switch until display = desired byte number. (Refer to option definition below.)
2. Use STEP and TEST switches to enter the value desired in the display.
3. Press EXECUTE switch. (When EXECUTE switch is released, display = next byte number.)
4. Power-down the STU to ensure transfer of option values into the interface PWA.

CE TEST 84 (BPEI): (Cont'd)

OPTION BIT  
DEFINITION:

Eight bytes of an EEPROM are used to store option selections. The left digit on the operator panel indicates in hex the value of bits 0 thru 3; the right digit indicates the value in hex of bits 4 thru 7 (see table 6-20). Execution of test 37 clears all the option bits (bits 1 thru 7) to 0. Bit 0 of each byte is a flag bit indicating whether any option selections have been entered in the byte via the operator panel and test 84. If no option(s) have been entered, the display value of bit 0 is 1, and the display value of the byte is 80. After any option selection has been entered via the operator panel, the display value of the flag bit (bit 0) is 0.

OPTION BIT  
PRIORITIES:

The buffer enable option, transfer rate selection, write start delay selection, remote density select option, adaptive velocity control option, and auto-read error recovery option are selectable both by test 84 and by jumpers on the buffered Pertec enhanced interface PWA. The priority of the selections is as follows:

- a. After test 37, which clears the option bits, and before any test 84 selection is entered, each byte display = 80. Under these conditions, the jumper selection prevails.
- b. After one or more selections is made in a byte via the operator panel and test 84, the content of the entire byte prevails over the jumper selections.
- c. For priorities in setting buffer mode or unbuffered mode, refer to figure 6-5A.

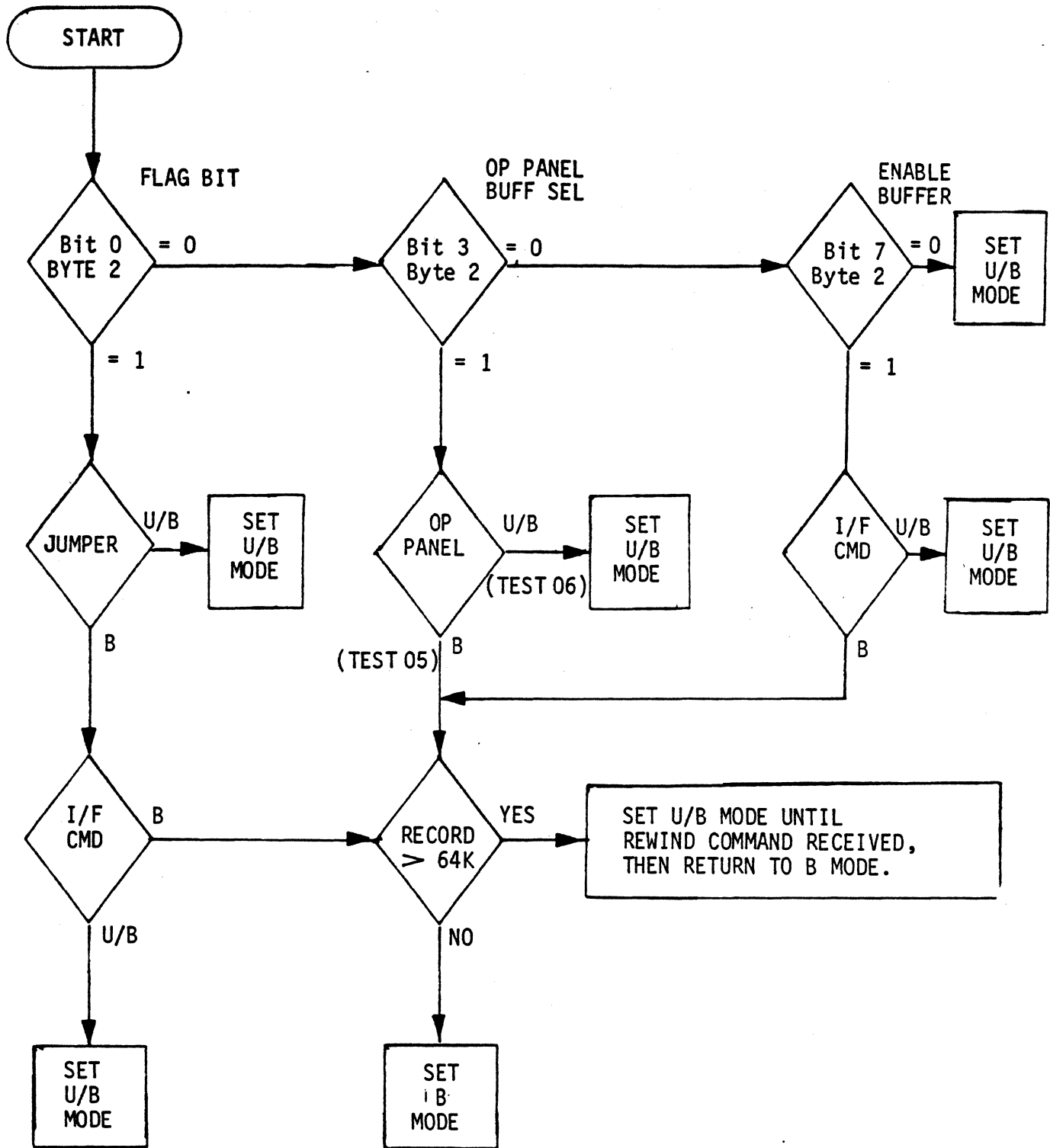

Figure 6-5A. Setting Buffered (B) or Unbuffered (U/B) Mode, buffered Pertec Enhanced I/F

CE TEST 84 (BPEI): (Cont'd)

a. Byte 1

Bit 0 = 0 - Selections entered in byte  
      = 1 - No selections entered in byte

Bit 1 - Reserved

Bit 2 = 0 - When AVC disabled, force high speed (75 ips)  
      = 1 - When AVC disabled, force low speed (25 ips)

Bit 3 = 0 - Disable AVC operation  
      = 1 - Enable AVC operation

Bit 4 - Not used

Bit 5 = 0 - Enable density status indication on interface  
      = 1 - Interface always indicates PE status

Bit 6 = 0 - Enable local density selection (front panel  
          switch)  
      = 1 - Enable remote density selection by interface

Bit 7 = 0 - READY (RDY) status independent of ON-LINE  
          (ONL) status  
      = 1 - READY (RDY) status not generated until  
          ON-LINE (ONL) status is true

CE TEST 84 (BPEI): (Cont'd)

b. Byte 2

Bit 0 = 0 - Selections entered in byte  
= 1 - No selections entered in byte

Bit 1 - Not used

Bit 2 = 0 - Enable read strobes during read-after-write  
operation  
= 1 - Disable read strobes during read-after-write  
operation

Bit 3 = 0 - Disable operator panel buffer selection  
= 1 - Enable operator panel buffer selection  
(Test 05 - Enable Buffer From Operator Panel)  
(Test 06 - Disable Buffer From Operator Panel)

Bit 4 - Not used

Bit 5 = 0 - Disable perfect write  
= 1 - Enable perfect write (no corrected errors  
allowed, buffered mode only)

Bit 6 = 0 - Disable read error recovery  
= 1 - Enable read error recovery

Bit 7 = 0 - Disable buffer operation  
= 1 - Enable buffer operation

CE TEST 84 (BPEI): (Cont'd)

c. Byte 3

Bit 0 = 0 - Selections entered in byte  
 = 1 - No selections entered in byte

Bits 1 thru 3 - Number of records allowed in buffer at  
 Early EOT during Write.

<u>Bit 1</u>	<u>Bit 2</u>	<u>Bit 3</u>	<u>No. of Records</u>
*0	0	0	0
0	0	1	1
0	1	0	2
0	1	1	3
1	0	0	4
1	0	1	5
1	1	0	6
1	1	1	7

\* If no bits are set, unit will go to  
 unbuffered mode at Early EOT.

Bits 4 thru 7 - Transfer rate selection

<u>4</u>	<u>5</u>	<u>6</u>	<u>7</u>	<u>Display</u>	<u>kilobytes/second</u>
0	0	0	0	0	62.5
0	0	0	1	1	125
0	0	1	0	2	189
0	0	1	1	3	250
0	1	0	0	4	313
0	1	0	1	5	385
0	1	1	0	6	435
0	1	1	1	7	500
1	0	0	0	8	555
1	0	0	1	9	625
1	0	1	0	☐ = A	714
1	0	1	1	☐ = B	770
1	1	0	0	☐ = C	770
1	1	0	1	☐ = D	770
1	1	1	0	☐ = E	770
1	1	1	1	BLANK = F	770

CE TEST 84 (BPEI): (Cont'd)

d. Byte 4

Bit 0 = 0 - Selections entered in byte  
      = 1 - No selections entered in byte

Bits 1 thru 5 - Not used

Bits 6 and 7 - Write start delay (pseudo ramp) selection

6      7

0	0	1-2 milliseconds
0	1	4-6 milliseconds
1	0	8-12 milliseconds
1	1	12-18 milliseconds

e. Byte 5

Bit 0 = 0 - Selections entered in byte  
      = 1 - No selections entered in byte

Bit 1 - Not used

Bit 2 = 0 - Disable conversion of READ REVERSE command to  
          BACKSPACE  
      = 1 - Enable conversion of READ REVERSE command to  
          BACKSPACE

Bits 3 and 4 - Not used

Bit 5 = 0 - Normal load  
      = 1 - Auto load

Bit 6 = 0 - Standard panel display  
      = 1 - Display 40 when in unbuffered mode

Bit 7 = 0 - Standard panel display  
      = 1 - Display 62 for GCR mode, or 16 for PE mode

f. Bytes 6 thru 8 - Not assigned



49763000 M

Table 6-20. OPTION BYTES BPEI INTERFACE (STATUS WHEN BITS SET TO 1)

BYTE	<u>LEFT DISPLAY DIGIT</u>				<u>RIGHT DISPLAY DIGIT</u>			
	0	1	2	3	4	5	6	7
1	FLAG BIT	RESERVED	FORCE LO SPD WHEN AVC NOT ENABLED  ENABLED NOTE 1	AVC  *ENABLED		DENSITY STATUS ON I/F  *DISABLED	REMOTE DENSITY SELECT  #ENABLED	RDY = RDY·ONL  #ENABLED
2	FLAG BIT		KD-AFTER-WR STROBES  DISABLED NOTE 1	OP PANEL BUFFER SELECTION ENABLED NOTE 1		PERFECT WRITE  ENABLED NOTE 1	AUTO-RD ERROR RECOVERY *ENABLED	ENABLE BUFFER  *ENABLED
3	FLAG BIT	RECORDS IN BUFFER AT EEOI IN WRITE MODE			TRANSFER RATE SELECTION			
4	FLAG BIT						WRITE START DELAY	
5	FLAG BIT		CONVERT RDB TO BSB ENABLED NOTE 1			AUTO LOAD FEATURE	40 DISPLAY ENABLED NOTES 1&2	16/62 DISPLAY ENABLED NOTES 1&2
6								
7								
8								

Blank blocks are unassigned.

Flag bit = 1 - No options entered

Flag bit = 0 - Options entered

NOTE 1: Option selectable only via test 84; no hardware jumper.

NOTE 2: If both 40 display and 16/62 display options are enabled, 40 display option prevails.

\* Shipped enabled by jumper.

# Shipped disabled by jumper.

6-183J

This page left blank intentionally.

CE TEST 84 (BSTCE): SELECT/EXAMINE STU OPTIONS

NOTE

Test 84, buffered STC enhanced interface (BSTCE) includes only the STU options available with the buffered STC enhanced interface. For a description of the STU options available with the buffered standard enhanced interface, refer to the preceding test - Test 84 (BPEI).

TEST REQUIREMENT: Interface PWA must be buffered STC enhanced version. Tape must not be loaded.

TEST DESCRIPTION: Test 84 allows the examining or changing of STU options.

TEST OPTIONS: None.

TEST SEQUENCE

a. To examine options:

1. Enter CE test 84.
2. Press and hold EXECUTE switch. Display = 01 (byte 1).
3. Release EXECUTE switch. Display = value stored in byte 1.
4. Press and hold EXECUTE switch. Display = 02 (byte 2).
5. Release EXECUTE switch. Display = value stored in byte 2.

This sequence may be continued through byte 8. If no selections have been entered in a byte, display = 80 (most significant bit = 1, all others = 0).

b. To select or change options:

1. Enter CE test 84. Press and release EXECUTE switch until display = desired byte number. (Refer to option definition below.)
2. Use STEP and TEST switches to enter the value desired in the display.
3. Press EXECUTE switch. (When EXECUTE switch is released, display = next byte number.)
4. Power-down the STU to ensure transfer of option values into the interface PWA.

CE TEST 84 (BSTC E): (Cont'd)

OPTION BIT  
DEFINITION:

Eight bytes of an EEPROM are used to store option selections. The left digit on the operator panel indicates in hex the value of bits 0 thru 3; the right digit indicates the value in hex of bits 4 thru 7 (see table 6-20). Execution of test 37 clears all the option bits (bits 1 thru 7) to 0. Bit 0 of each byte is a flag bit indicating whether any option selections have been entered in the byte via the operator panel and test 84. If no option(s) have been entered, the display value of bit 0 is 1, and the display value of the byte is 80. After any option selection has been entered via the operator panel, the display value of the flag bit (bit 0) is 0.

OPTION BIT  
PRIORITIES:

The buffer enable option, remote density select option, adaptive velocity control option, and auto-read error recovery option are selectable both by test 84 and by jumpers on the buffered STC enhanced interface PWA. The priority of the selections is as follows:

- a. After test 37, which clears the option bits, and before any test 84 selection is entered, each byte display = 80. Under these conditions, the jumper selection prevails.
- b. After one or more selections is made in a byte via the operator panel and test 84, the content of the entire byte prevails over the jumper selections.
- c. For priorities in setting buffer enabled mode or buffer disabled mode, refer to figure 6-5B.

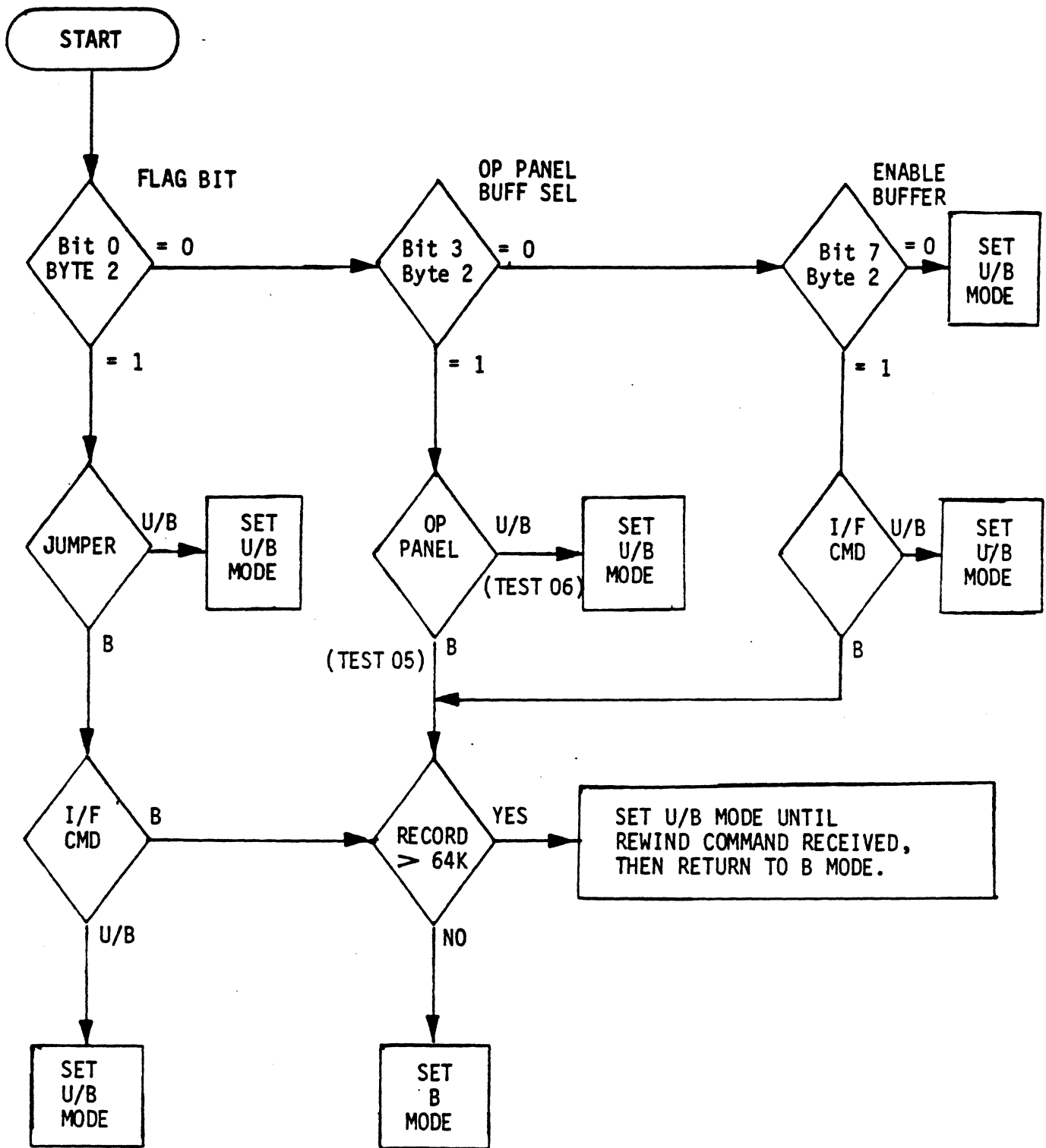

Figure 6-5B. Setting Buffered (B) or Unbuffered (U/B) Mode, Buffered STC Enhanced I/F

CE TEST 84 (BSTC E): (Cont'd)

a. Byte 1

Bit 0 = 0 - Selections entered in byte  
      = 1 - No selections entered in byte

Bit 1 - Reserved

Bit 2 = 0 - When AVC disabled, force high speed (75 ips)  
      = 1 - When AVC disabled, force low speed (25 ips)

Bit 3 = 0 - Disable AVC operation  
      = 1 - Enable AVC operation

Bit 4 - Not used

Bit 5 - Reserved for buffered standard enhanced interface

Bit 6 = 0 - Enable local density selection (front panel  
          switch)  
      = 1 - Enable remote density selection by interface

Bit 7 = 0 - READY (RDY) status independent of ON-LINE  
          (ONL) status  
      = 1 - READY (RDY) status not generated until  
          ON-LINE (ONL) status is true

b. Byte 2

Bit 0 = 0 - Selections entered in byte  
      = 1 - No selections entered in byte

Bit 1 - Not used

Bit 2 - Reserved for buffered standard enhanced interface

Bit 3 = 0 - Disable operator panel buffer selection  
      = 1 - Enable operator panel buffer selection  
          (Test 05 - Enable Buffer From Operator Panel)  
          (Test 06 - Disable Buffer From Operator Panel)

Bit 4 - Not used

CE TEST 84 (BSTCE): (Cont'd)

Bit 5 = 0 - Disable perfect write  
      = 1 - Enable perfect write (no corrected errors allowed, buffered mode only)

Bit 6 = 0 - Disable read error recovery  
      = 1 - Enable read error recovery

Bit 7 = 0 - Disable buffer operation  
      = 1 - Enable buffer operation

c. Byte 3

Bit 0 = 0 - Selections entered in byte  
      = 1 - No selections entered in byte

Bits 1 thru 3 - Number of records allowed in buffer at Early EOT during Write.

<u>Bit 1</u>	<u>Bit 2</u>	<u>Bit 3</u>	<u>No. of Records</u>
*0	0	0	0
0	0	1	1
0	1	0	2
0	1	1	3
1	0	0	4
1	0	1	5
1	1	0	6
1	1	1	7

\* If no bits are set, unit will go to unbuffered mode at Early EOT.

Bits 4 thru 7 - Reserved for buffered standard enhanced interface

d. Byte 4

Bit 0 = 0 - Selections entered in byte  
      = 1 - No selections entered in byte

Bits 1 thru 5 - Not used

Bits 6 and 7 - Reserved for buffered standard enhanced interface

CE TEST 84 (BSTCE): (Cont'd)

e. Byte 5

Bit 0 = 0 - Selections entered in byte  
      = 1 - No selections entered in byte

Bit 1 - Not used

Bit 2 = 0 - Disable conversion of READ REVERSE command to  
          BACKSPACE  
      = 1 - Enable conversion of READ REVERSE command to  
          BACKSPACE

Bits 3 and 4 - Not used

Bit 5 = 0 - Normal load  
      = 1 - Auto load

Bit 6 = 0 - Standard panel display  
      = 1 - Display 40 when in unbuffered mode

Bit 7 = 0 - Standard panel display  
      = 1 - Display 62 for GCR mode, or 16 for PE mode

f. Bytes 6 thru 8 - Not assigned



49763000 N

Table 6-21. OPTION BYTES BSTCE INTERFACE (STATUS WHEN BITS SET TO 1)

	<u>LEFT DISPLAY DIGIT</u>				<u>RIGHT DISPLAY DIGIT</u>			
BYTE	0	1	2	3	4	5	6	7
1	FLAG BIT	RESERVED	FORCE LO SPD WHEN AVC NOT ENABLED  ENABLED NOTE 1	AVC  *ENABLED		RESERVED	REMOTE DENSITY SELECT  #ENABLED	RDY = RDY·ONL  ENABLED NOTE 1
2	FLAG BIT		RESERVED	OP PANEL BUFFER SELECTION ENABLED NOTE 1		PERFECT WRITE  ENABLED NOTE 1	AUTO-RD ERROR RECOVERY *ENABLED	ENABLE BUFFER  *ENABLED
3	FLAG BIT	RECORDS IN BUFFER AT EEOT IN WRITE MODE			RESERVED			
4	FLAG BIT						RESERVED	
5	FLAG BIT		CONVERT RDB TO BSB ENABLED NOTE 1			AUTO LOAD FEATURE	40 DISPLAY ENABLED NOTES 1&2	16/62 DISPLAY ENABLED NOTES 1&2
6								
7								
8								

Blank blocks are unassigned.

Flag bit = 1 - No options entered

Flag bit = 0 - Options entered

NOTE 1: Option selectable only via test 84; no hardware jumper.

NOTE 2: If both 40 display and 16/62 display options are enabled, 40 display option prevails.

\* Shipped enabled by jumper.

# Shipped disabled by jumper.

6-185F

This page left blank intentionally.

CE TEST 91: FUNCTIONAL FAULT DETECTION TEST

TEST REQUIREMENT: A write-enabled scratch tape must be threaded. The tape may be loaded or not loaded.

TEST DESCRIPTION: Test 91 performs those functions that the STU would normally perform during functional operations. Unit halts with the appropriate error code, if a functional fault occurs. Test 91 is the same as test 01, except that test 91 will start in a loaded or unloaded condition and EGC test is bypassed.

TEST OPTIONS:

- 00 = Halt if read or write errors exceed limits specified, halt on completion of test (Default option).
- 01 = Loop on test, halt if read or write errors exceed limit specified on any given pass.
- 02 = Loop on test, bypass read or write error halts.

## NOTE

Option of halting or bypassing errors applies only to read/write type errors; all other errors cause test to halt, with appropriate fault code displayed, regardless of the option selected.

## TEST SEQUENCE:

- a. If tape is unloaded then load tape; otherwise, rewind tape.
- b. WRITE 100 blocks in PE mode at 25 ips start/stop (see NOTE 1).
- c. SPACE REVERSE, ERASE, and WRITE FILE MARK (check for file mark detected). SPACE REVERSE and check for file mark detected. READ FORWARD and again check for file mark detected.
- d. READ REVERSE 100 blocks at 25 ips start/stop.
- e. READ FORWARD 100 blocks at 25 ips start/stop.

## CE TEST 91: (Cont'd)

- f. Repeat steps b thru e at 25 ips streaming.
- g. Repeat steps b thru e at 75 ips streaming.
- h. WRITE 10 blocks at 75 ips "thrashing" (see NOTE 2).
- i. READ REVERSE 10 blocks at 75 ips "thrashing".
- j. READ FORWARD 10 blocks at 75 ips "thrashing".
- k. REWIND.
- l. READ FORWARD 300 blocks at 75 ips streaming. Check for file mark detected at blocks 100, 200, and 300.
- m. REWIND.
- n. Repeat steps b thru e for GCR mode and SPACE REVERSE where READ REVERSE is specified.
- o. WRITE to EOT in GCR mode at 75 ips streaming (see NOTE 1).
- p. SPACE REVERSE 1000 records at 75 ips streaming (reposition after every 250 records).
- q. Write to EOT in GCR mode at 25 ips streaming.
- r. REWIND.

NOTE 1: Data blocks written are 2K bytes with an incrementing pattern starting at zero for each block.

NOTE 2: Data blocks written are 256 bytes with an incrementing pattern starting at zero for each block.

## POSSIBLE DIAGNOSTIC CODES:

- 00 - Test is successful
- Fault Codes
- 01 - Read envelope fault
- 02 - Read amplitude range fault
- 03 - ID check
- 04 - Low speed write error
- 05 - Low speed read error
- 06 - High speed write error
- 07 - High speed read error
- 08 - Noise in IBG
- 09 - Hardware failure
- 10 thru 69 - Refer to Structured Analysis Method (SAM)

CE TEST 97: READ/WRITE COMMAND STACK

TEST REQUIREMENT: None.

TEST DESCRIPTION: Test 97 allows the CE to set up a command stack using READ, WRITE, SPACE, and ERASE commands. Up to three commands can be entered. The commands available are:

READ FORWARD - 00  
READ REVERSE - 80  
SPACE FORWARD - 08  
SPACE REVERSE - 88  
WRITE PE - 40  
ERASE - 58  
NO-OP - 70 or 01 (included to allow  
"in-place" analysis)  
WRITE FILE MARK PE - 50  
REWIND - 74  
WRITE GCR - 41  
WRITE FILE MARK GCR - 51

TEST OPTIONS: None.

## TEST SEQUENCE:

- a. Set up for test 97 and press EXECUTE.
- b. Display goes to 00 - enter first desired command using STEP and TEST (to multiply by 10) and press EXECUTE.
- c. Repeat step b two more times to enter second and third commands.
- d. After third entry, display goes to 00 and fault indicator lights. Test is terminated.

## POSSIBLE DIAGNOSTIC CODES:

99 - Illegal remote test

NOTE 1: Tests 28 and 29 cause execution of the commands set up in this command stack routine.

This page left blank intentionally.

# REMOVAL/REPLACEMENT PROCEDURES

---

## GENERAL

This subsection of the manual contains information for the removal and replacement of parts or assemblies as defined in the spare parts list. In addition, a verification test follows each of the replacement procedures. The reader should be thoroughly familiar with the operation of the STU and with the diagnostic test procedures.

It is assumed that any part or assembly being replaced has been determined to be defective. If an adjustment procedure is included as part of the procedure, then the adjustment must be attempted before a part or assembly is replaced. In addition, the adjustment must also be performed following the replacement procedure.

Unless otherwise stated, for all procedures it is assumed that tape has been unloaded, the transport is powered down, and the input power cord is disconnected. For component location, refer to figures 6-6A, 6-6B, and 6-6C.

Table 6-16. REMOVAL/REPLACEMENT INDEX

---

1. Drive Cover	11. Pressure Regulator/Filter
2. Tape Cleaner	12. Magnetic Head
3. Door Interlock Switch	13. Operator Panel
4. File Protect Sensor	14. Cooling Fan
5. EOT/BOT Sensor	15. Power Supply
6A. Take-Up Reel Hub	16. Capacitor
6B. Take-Up Reel Motor	17. Write Driver PWA
7A. Supply Reel Hub	18. Read Amplifier PWA
7B. Supply Reel Motor	19. Servo-Control PWA
7C. Supply Reel Tach and Sensor	20. Formatter Read PWA
8. Air Bearing Sensor	21. Formatter Write PWA
9. Air Bearing Spring Guides	22. Interface PWA
10. Compressor	23. Power Driver PWA

---

Figure 6-6A. STU Component Location

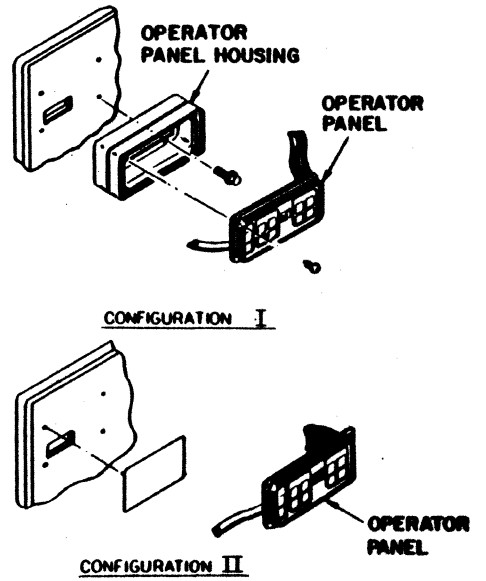
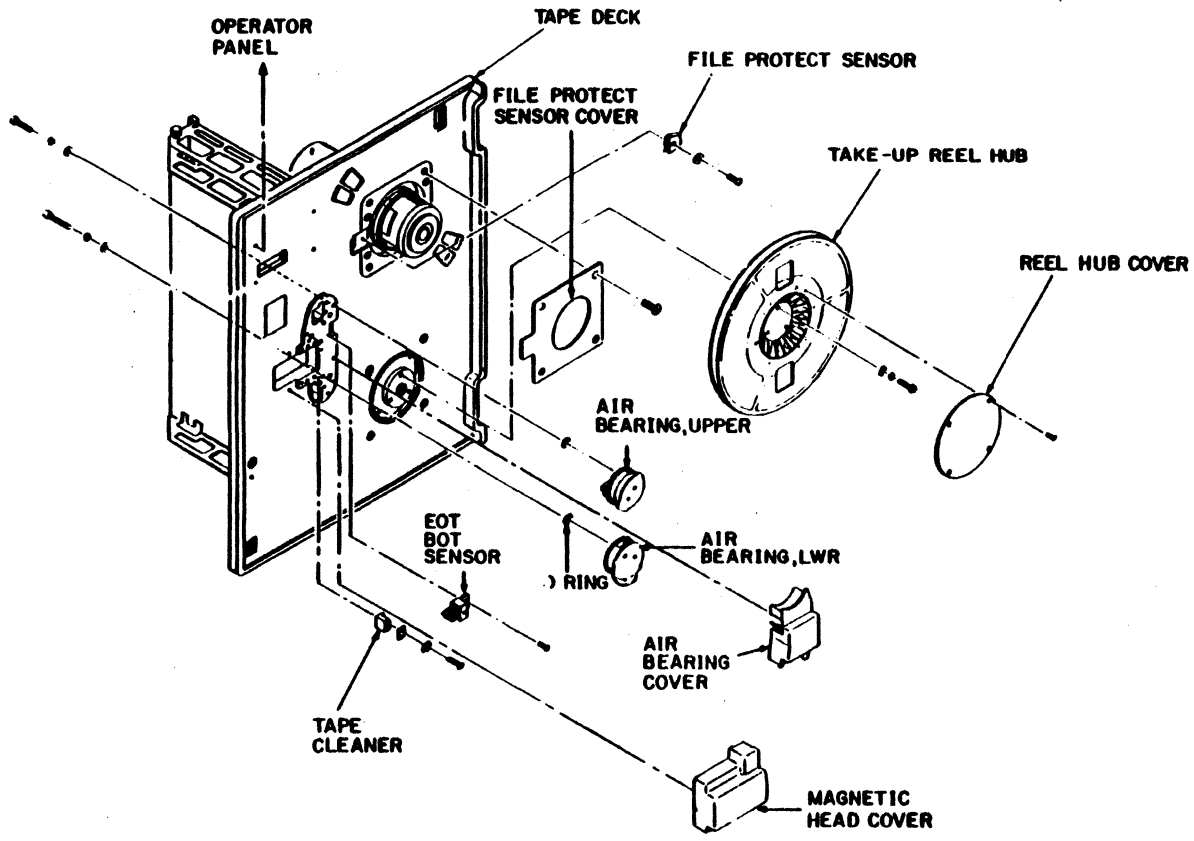



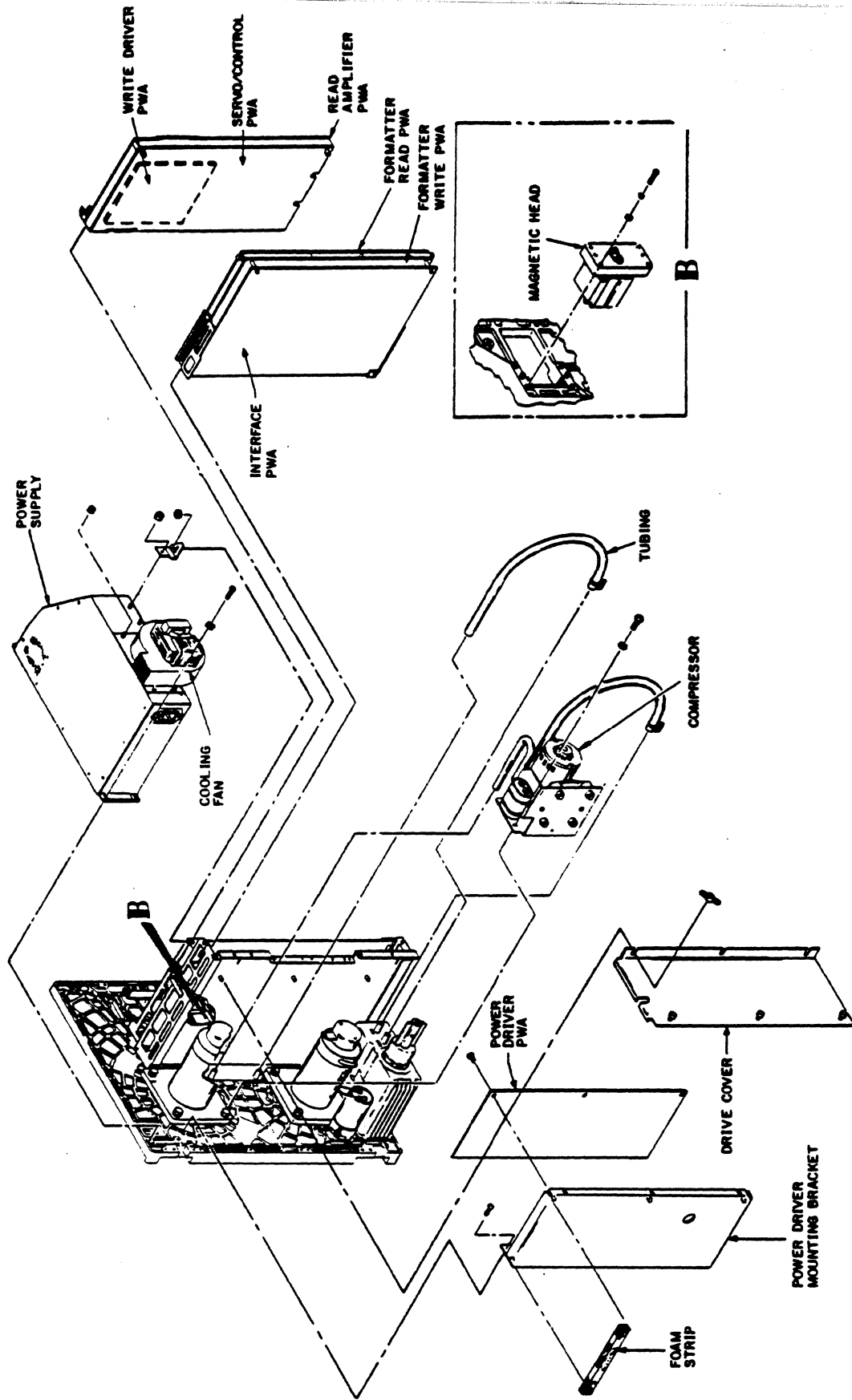

Figure 6-6B. STU Component Location

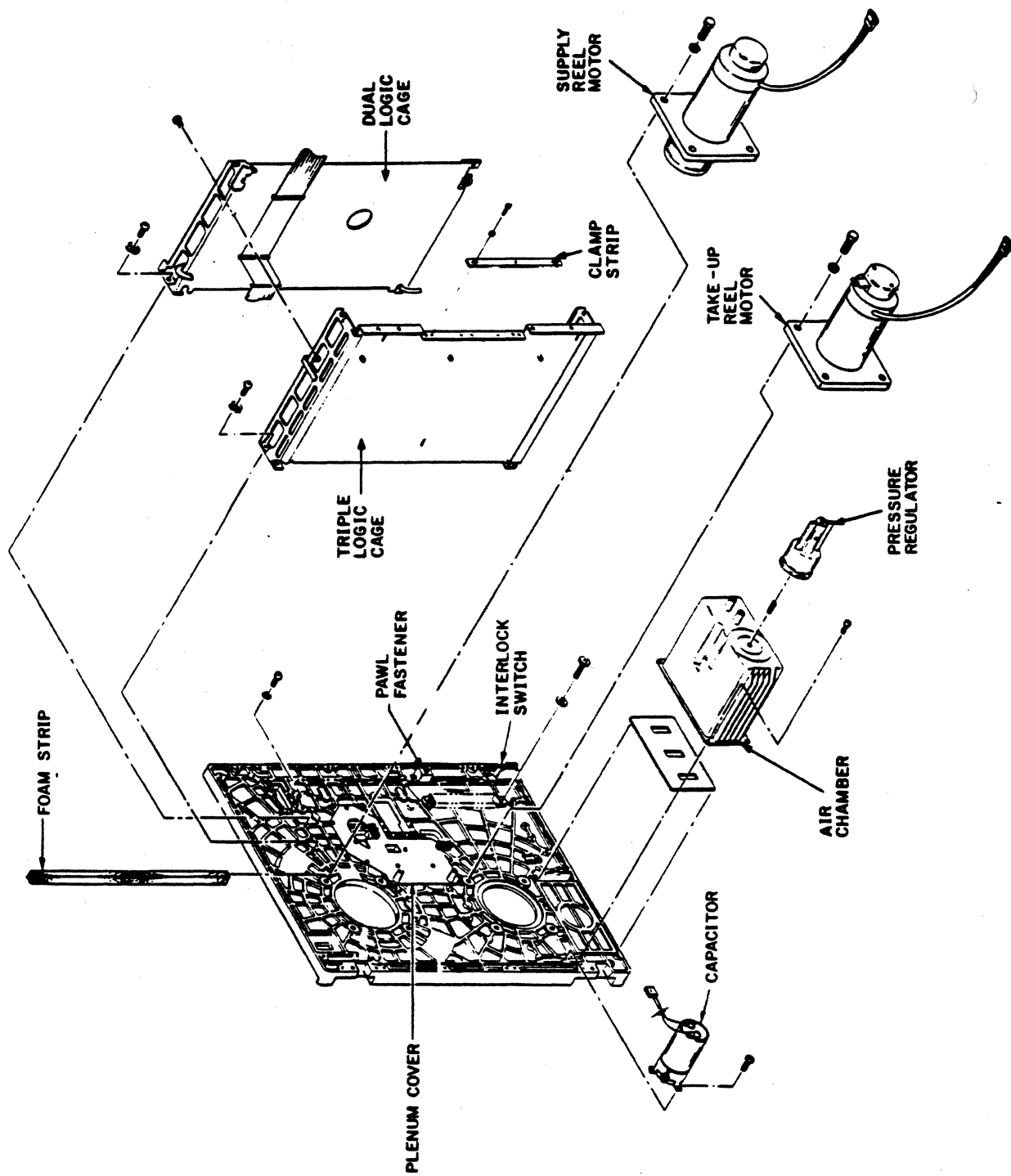

Figure 6-6C. STU Component Location

## MAINTENANCE POSITION (ACCESS TO REAR COMPONENTS)

Components located at the rear of the tape deck can be accessed for maintenance purposes by first placing the tape deck in the maintenance position. Using Figure 6-7 for reference, proceed as follows:

1. Open the front dust cover door.
2. Using a straight slot screwdriver, rotate the pawl fastener on the lower left side of the tape deck one-half turn counterclockwise to release the tape deck. Rotate the fastener six more turns counterclockwise to disengage the pawl fully.
3. The tape deck can now be swung to the fully opened position to access rear components.
4. To return the tape deck to the operating position, swing the tape deck to the closed position. While holding tape deck in the closed position, rotate the pawl fastener until the transport is secured to the mounting rack.

## FRONT COVER INTERLOCK SWITCH

The front cover interlock switch prevents operation of the STU if the front cover is not secured. If the customer engineer is required to operate the transport with the front cover open, the interlock switch can be bypassed by using the interlock override key. Insert the key as shown in Figure 6-7 and rotate the key one-quarter turn to lock the key into the interlock switch. This keeps the interlock switch depressed, simulating the "door closed" condition.

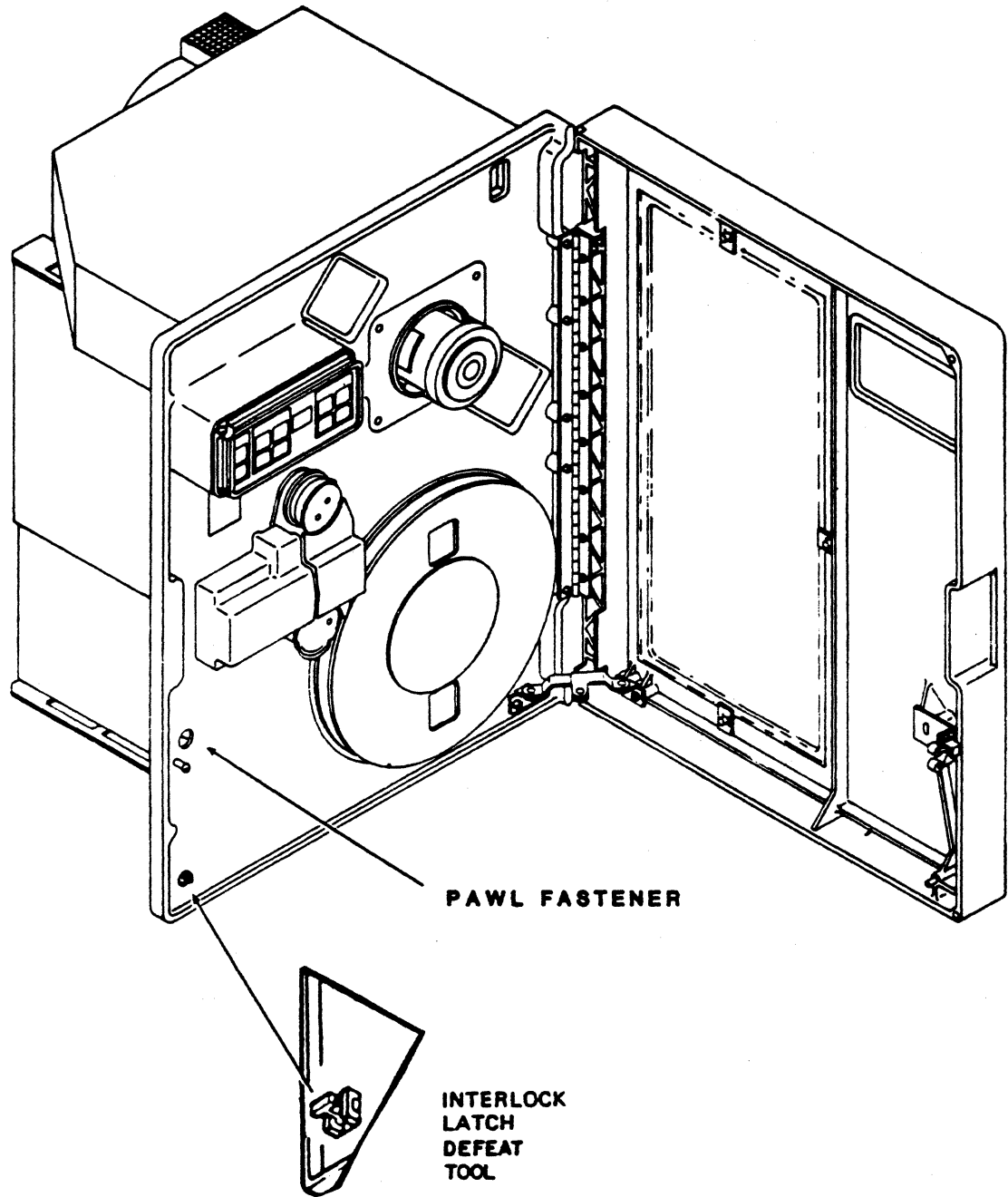

PAWL FASTENER

INTERLOCK  
LATCH  
DEFEAT  
TOOL

Figure 6-7. Access to Rear Tape Deck Components

## DRIVE COVER REMOVAL/REPLACEMENT

### Removal

1. Place the tape deck in the maintenance position.
2. Loosen the nuts and the screws securing the cover and remove the drive cover assembly (figure 6-8). (The drive cover assembly consists of the drive cover with attached foam strips and grommet.)

### Replacement

1. Place the drive cover assembly in position so that the cooling fan wires are placed in the feed-thru hole.
2. Secure the cover with the nuts and the screws.
3. Return the tape deck to the operating position.

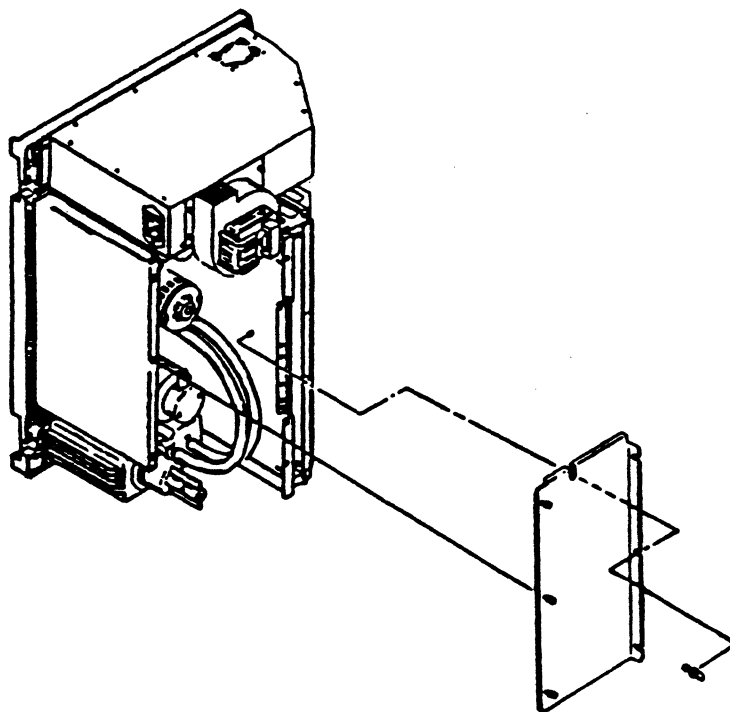

Figure 6-8. Drive Cover Removal

## TAPE CLEANER REMOVAL/REPLACEMENT

### Removal

1. Remove the tape path cover and magnetic head covers from the tape deck.
2. Loosen the two mounting screws and remove the cleaner assembly from the tape deck. See figure 6-9.
3. Remove screws, lockwashers and cover plate from the blade housing.
4. Slide the platform out from the tape cleaner assembly.

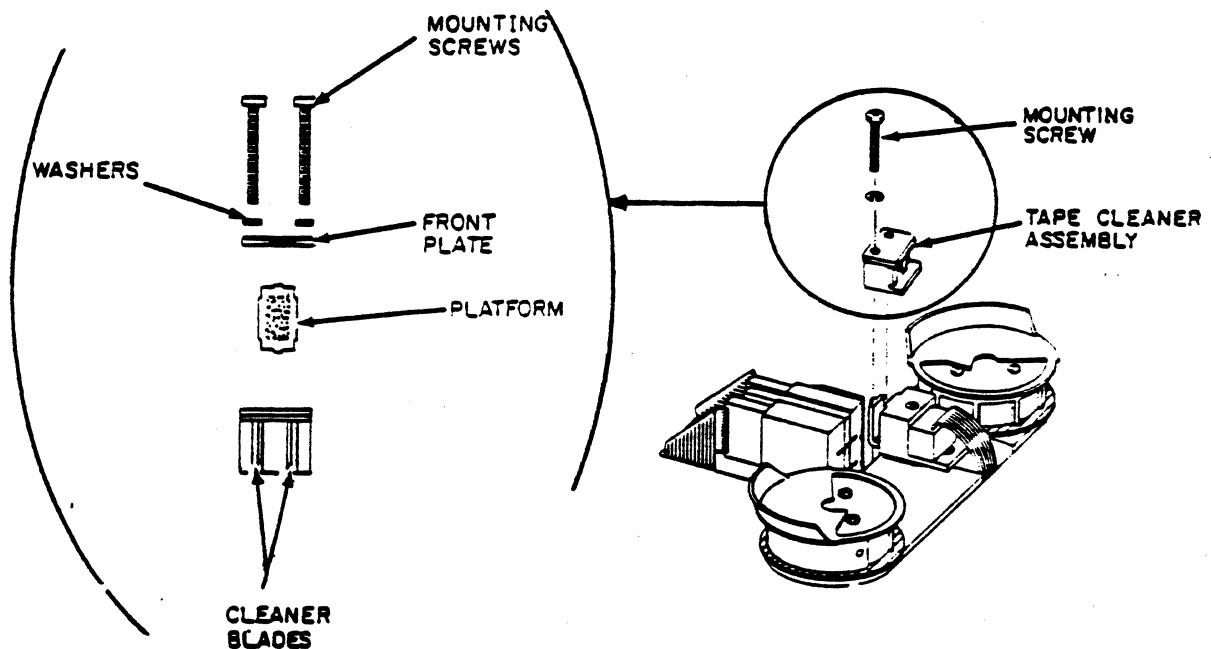

Figure 6-9. Tape Cleaner

### CAUTION

Handle the assembly with care. The cleaner blades are both brittle and sharp.

### NOTE

The defective tape cleaner must be replaced as a complete assembly.

## TAPE CLEANER REMOVAL/REPLACEMENT (Cont'd)

### Replacement

1. Inspect cleaner blades for damage. If blades are chipped or damaged, replace entire assembly.
2. If blades are not damaged, clean platform and reinstall. When installing platform, ensure flanges are such that platform fits firmly inside cleaner assembly.
3. Install cover plate, two washers and mounting screws.
4. Position assembly onto guide pins on tape deck and secure screws.
5. Reinstall tape path and magnetic head covers.

### Verification Check

1. No functional checks are necessary.

## DOOR INTERLOCK SWITCH REMOVAL/REPLACEMENT

### Removal

1. At the rear of the tape deck, remove four labeled slip-on connectors from interlock switch connectors. (If any wires are not labeled, identify and mark each wire for reassembly.)
2. Remove two hex head screws securing switch plate to tape deck. Remove switch and switch plate.
3. Depress top and bottom release tabs on switch to separate switch from switch plate.

### Replacement

1. Assemble switch to switch plate.
2. Position switch assembly on the rear of the tape deck so that connector numbers on switch correspond to numbers stencilled on tape deck.
3. Insert two hex mounting screws. Position front dust cover door so that interlock switch can be aligned with actuating stud on door. Tighten switch mounting screws when center of switch front is aligned with actuating stud.
4. Attach slip-on connectors to appropriate studs of interlock switch. Refer to figure for wire and connector positions.

### Verification Checks

1. With tape threaded, but not loaded, execute operator test 01. If test is successful, test terminates with display 00. If test fails, refer display number to corresponding fault SAM.

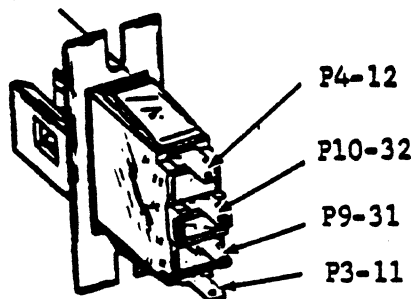

Figure 6-10. Door Interlock Switch (Rear View)



## FILE PROTECT SENSOR REMOVAL/REPLACEMENT

### Removal

1. Remove tape reel from supply hub.
2. Remove four mounting screws and file protect sensor cover plate from tape deck.
3. Remove mounting screw and washer securing file protect sensor to tape deck.
4. Detach connector W3P6 from sensor and discard sensor.

### Replacement

#### NOTE

Refer to figure 6-11 for sensor alignment and cable plug connection.

1. Place sensor on tape deck and secure with mounting screw and washer.
2. Attach cable plug W3P6 to sensor pins.
3. Reinstall sensor cover plate and secure to tape deck with four mounting screws.

### Verification Check

1. Perform SAM 1003 to verify operation of file protect sensor circuit.

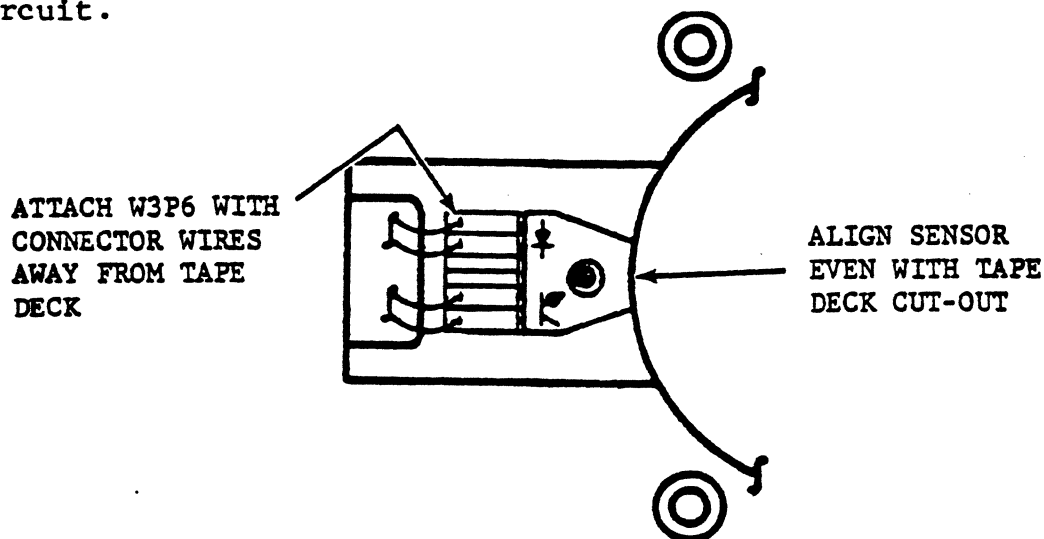

Figure 6-11. File Protect Sensor Alignment

## EOT/BOT SENSOR REMOVAL/REPLACEMENT

### Removal

1. Remove tape path and magnetic head covers from tape deck.
2. Disconnect W3P1 plug from EOT/BOT assembly (see figure 6-12).
3. Remove flat head phillips mounting screw from assembly base-mount and assembly from tape deck.

### NOTE

Defective sensor must be replaced as a complete assembly.

### Replacement

1. Position EOT/BOT assembly onto tape deck and install flat head mounting screw.
2. Thread tape onto take-up reel and align EOT/BOT assembly so that assembly is perpendicular to tape.
3. Tighten flat head mounting screw.
4. Reattach W3P1 plug to assembly connector as shown. If excess cable exists, position cable so that excess is at the rear of tape deck.
5. Install tape path and magnetic head covers.

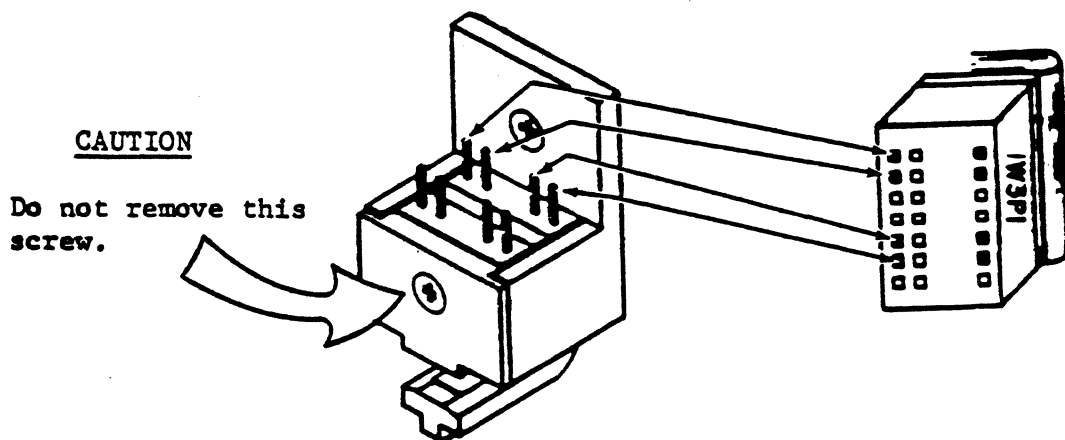

Figure 6-12. EOT/BOT Sensor

## EOT/BOT SENSOR REMOVAL/REPLACEMENT (Cont'd)

### Verification Check

#### NOTE

If available, use a 600 foot reel of tape with properly installed EOT/BOT markers to reduce test time.

1. Load a reel of tape onto supply hub and thread tape so that BOT marker is located before EOT/BOT assembly.
2. Perform a load operation and observe that tape loads and positions itself at BOT marker (BOT indicator lights).
3. Execute test 44 to verify operation of EOT sensor. If tape does not stop when EOT is reached, refer to TROUBLE ANALYSIS section for procedures.

## TAKE-UP REEL HUB REMOVAL/REPLACEMENT

### Removal

1. Remove four mounting screws from take-up reel hub cover and remove cover from hub assembly (refer to figure 6-13).
2. Remove three allen screws, lockwashers and plain washers securing reel to motor shaft assembly.
3. Remove take-up reel from transport.

### Replacement

#### CAUTION

If a new reel is being installed, inspect reel edges for burrs or cracks that could cause tape damage.

1. Perform Removal procedure in reverse order.

### Verification Checks

1. Manually rotate tape reel to ensure reel does not contact tape deck.
2. Load a known good reel of tape and observe reel during tape motion. Tape should not contact reel flanges.

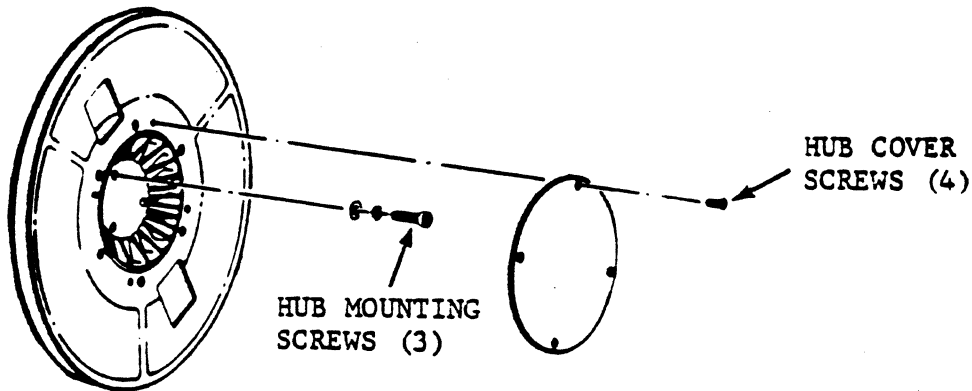

Figure 6-13. Take-Up Reel

## TAKE-UP REEL MOTOR REMOVAL/REPLACEMENT

### Removal

1. Perform Removal procedure for take-up reel hub.
2. Detach connector W3P2 from tach assembly on rear of take-up motor.
3. Detach B3P1 connector from power driver board (connector J1 on power driver).
4. Detach W7P7 connector from power driver board (connector J4 on power driver).
5. Remove four mounting screws securing motor to rear of tape deck. Remove motor from transport.

### Replacement

#### NOTE

Reel motor and tach must be replaced as an assembly.

#### CAUTION

When installing motor, make sure there are no loose wires between motor mounting plate and tape deck.

1. Position motor on rear of tape deck so that B3P1 cable extends from upper left of motor assembly if STU is mounted vertically, or lower right if STU is mounted horizontally. Secure with four mounting screws.
2. Connect B3P1 to J1 on power driver board.
3. Connect W3P2 to tach assembly on rear of motor.
4. Connect W7P7 to J4 on power driver board.
5. Perform Replacement procedure for take-up reel hub.

## TAKE-UP REEL MOTOR REMOVAL/REPLACEMENT (Cont'd)

### Verification Check

1. Execute test 37 (refer to test description for requirements).
2. Execute test 48 (refer to test description for requirements).
3. Thread tape (not loaded) and execute operator test 01. If test is successful, test will terminate with display 00. If test fails, refer display number to the corresponding fault SAM.
4. If power-on auto-load option was enabled before service, execute test 50.

This page intentionally left blank.

## SUPPLY REEL HUB REMOVAL/REPLACEMENT

### Removal

1. Press center button on hub to put hub into the unlatched position.
2. Locate slot opening on periphery of cover. Insert small blade screwdriver into slot and twist to unsnap cover from hub assembly.
3. Place hub assembly in the latched position by depressing cam carrier.

### CAUTION

Ensure hub is latched before proceeding with further removal. If hub is unlatched, piece parts may disassemble.

4. Remove three large shoulder screws from cam carrier. Hub assembly can then be removed from tape deck.

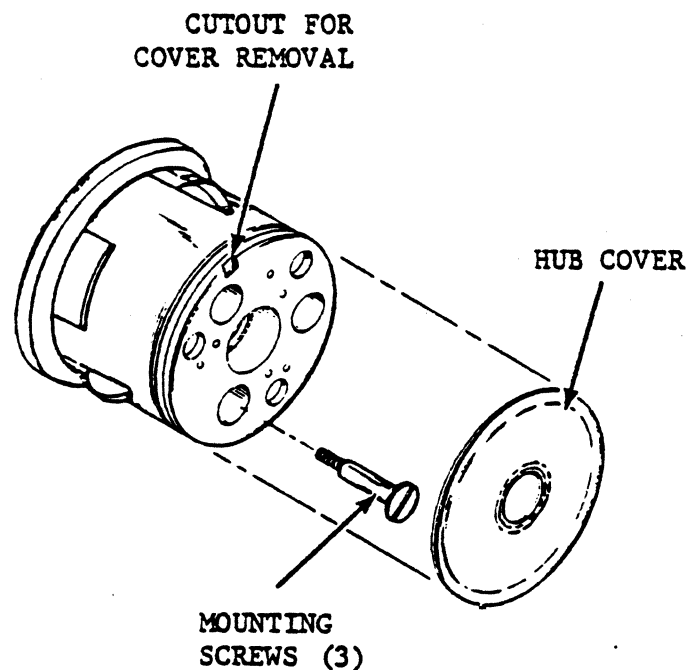

Figure 6-14. Supply Reel Hub Assembly



## SUPPLY REEL HUB REMOVAL/REPLACEMENT (Cont'd)

### Replacement

1. Position hub assembly onto motor shaft assembly and secure with three large shoulder screws.
2. Install cover on face of hub assembly.

### Verification Checks

1. Mount tape reel onto hub assembly. Reel should mount easily onto hub and against rear flange.
2. Latch reel onto hub. Ensure reel is securely fastened.
3. Load a known good quality tape and observe reel during tape motion. Tape should not contact reel flanges.
4. With tape threaded, but not loaded, execute operator test 01. If test is successful, test will terminate with display 00. If test fails, refer display number to corresponding fault SAM.

## SUPPLY REEL MOTOR REMOVAL/REPLACEMENT

### IMPORTANT

The supply reel motor assembly is not supplied as part of the spare parts list; the spared take-up reel motor assembly must be disassembled and the motor used as a replacement for the supply motor.

#### Removal

1. Perform Removal procedure for supply reel hub.
2. Detach B1P1 connector from J3 on power driver PWA.

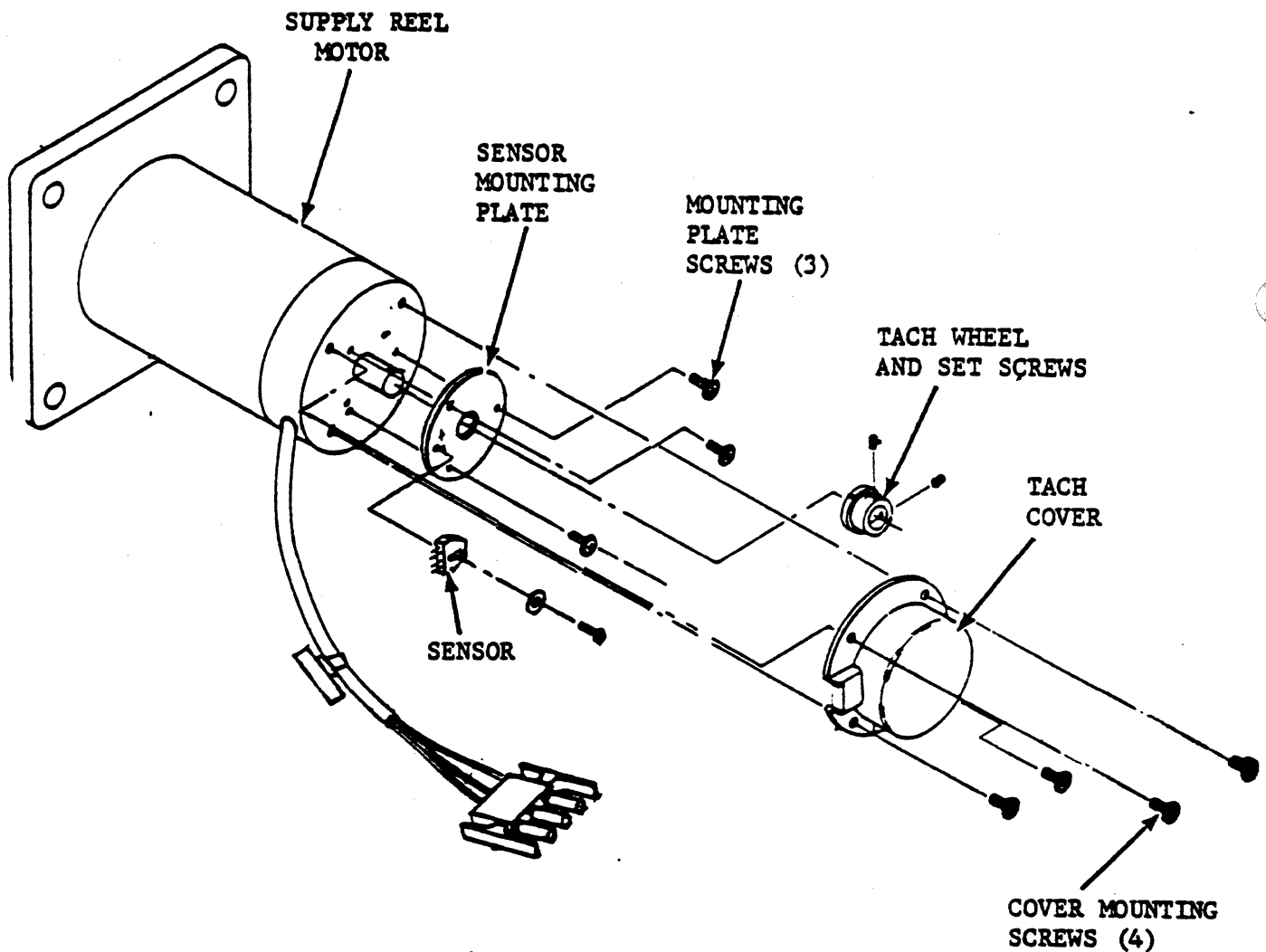

Figure 6-15. Supply Reel Assembly

## SUPPLY REEL MOTOR REMOVAL/REPLACEMENT

### Removal (Cont'd)

3. Remove four mounting screws and tach cover from rear of motor.
4. Detach W3P5 connector from tach assembly at rear of motor.
5. Remove four mounting screws securing motor to rear of tape deck. Remove motor from transport.
6. Remove mounting screw and sensor from mounting plate at rear of supply reel motor. Retain for reuse.
7. Loosen two set screws securing tach to motor shaft and remove tach from shaft. Retain for reuse.
8. Remove four screws securing mounting plate and remove plate from supply reel motor. Retain for reuse.

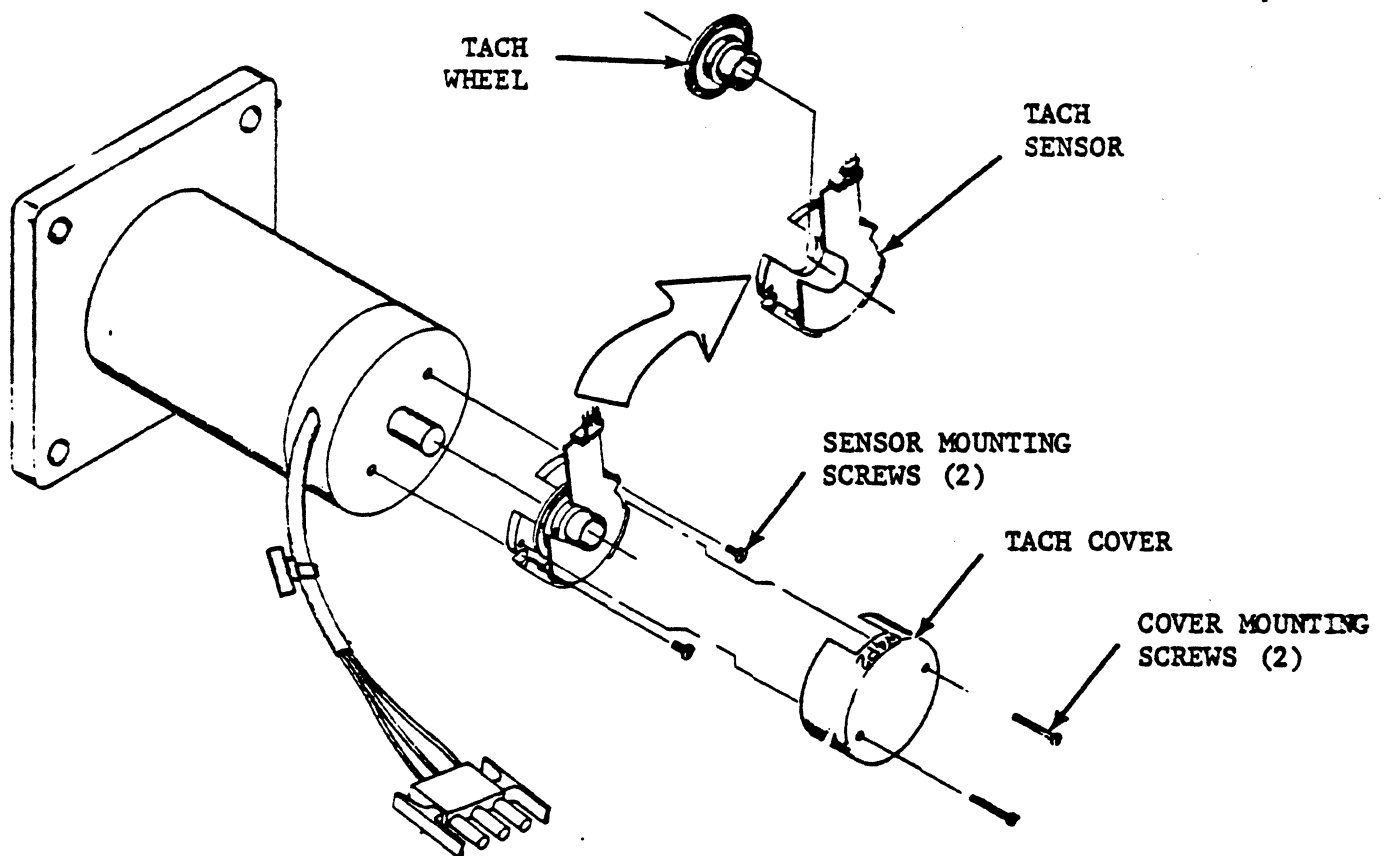

Figure 6-16. Take-Up Reel Motor Disassembly

## SUPPLY REEL MOTOR REMOVAL/REPLACEMENT

### Removal (Cont'd)

9. Disassemble spared take-up reel motor assembly as follows:
  - a. Remove two mounting screws and tach cover from rear of motor assembly.
  - b. Remove two mounting screws securing tach sensor to reel motor. Remove tach sensor from reel shaft and tach wheel.
  - c. Loosen set screw securing tach wheel and remove from motor shaft.
  - d. Return removed tach assembly:

COMPUTER PERIPHERALS INC.  
2621 Van Buren Avenue  
Valley Forge Corporate Center  
Norristown, PA. 19403

### Replacement

1. Place mounting plate (from step 8 of Removal) onto rear of new motor and secure with four mounting screws.
2. Assemble sensor and tach wheel (from steps 6 and 7 of Removal) onto rear of motor mounting plate and shaft as shown in figure 6-17 and adjust per tolerance requirements listed in the Supply Motor Tach and Sensor Procedures.

### CAUTION

When installing motor, ensure there are no loose wires between motor mounting plate and tape deck.

3. Position motor on rear of tape deck so that B1P1 cable extends from left of motor if STU is mounted vertically, or from the right. Secure motor with four mounting screws.
4. Connect B1P1 cable to J3 on power driver PWA.
5. Attach W3P5 connector to tach sensor pins as shown in figure 6-17.

## SUPPLY REEL MOTOR REMOVAL/REPLACEMENT

### Replacement (Cont'd)

6. Install tach cover and secure with four mounting screws.
7. Perform Replacement procedure for supply reel hub.

### Verification Check

1. With tape threaded, but not loaded, execute operator test 01. If test is successful, test will terminate with display 00. If test fails, refer display number to appropriate SAM table.

## SUPPLY REEL MOTOR TACH AND SENSOR REMOVAL/REPLACEMENT

### Removal

1. Remove four mounting screws and tach cover from rear of motor.
2. Detach W3P5 connector from sensor pins.
3. Remove mounting screw and sensor from mounting plate.
4. Loosen two set screws securing tach to motor shaft and remove tach from shaft.

### Replacement (Refer to Figure 6-17)

1. Insert tach wheel on motor shaft. Position tach for a  $0.030 \pm 0.005$  inch clearance between tach and sensor mounting plate.
2. Install sensor on mounting plate and position for a clearance of  $0.150 \pm 0.01$  inch between sensor and tach. Tighten sensor mounting screw.
3. Attach W3P5 connector to sensor pins.
4. Install tach cover and secure with four mounting screws.

### Verification Check

1. With tape threaded, but not loaded, execute operator test 01. If test is successful, test will terminate with display 00. If test fails, refer display number to corresponding fault SAM.

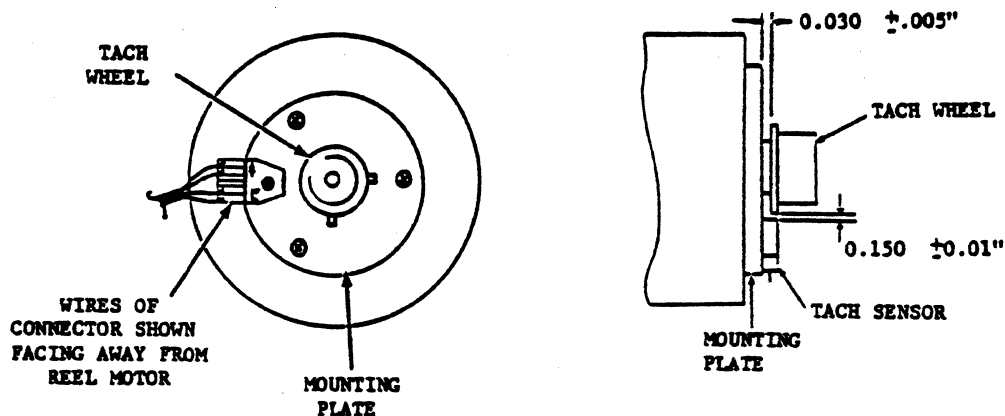

Figure 6-17. Tach/Sensor Assembly/Adjustments

## AIR BEARING SENSOR REMOVAL/REPLACEMENT

### Removal

#### NOTE

Replacement parts for air bearing assembly are contained in a refurbishment kit P/N 77015691. This kit contains an upper and lower spring guide, transducer, and a small and large O ring. If transducer is being replaced, it is recommended that upper and lower spring guides and large and small "O" rings also be replaced.

1. From the rear of the tape deck, remove P1 connector from the sensor pins.
2. To gain access to the screws holding the air bearing, perform the following:
  - a. Completely loosen both thumbwheels (top and bottom) to partially release the servo/read/write card set from the logic cage. Slide the card set out (figure 6-31).
  - b. Loosen the formatter card cage lock screws (top and bottom) and slide the formatter card set out until the top and bottom detents are engaged (figure 6-34).

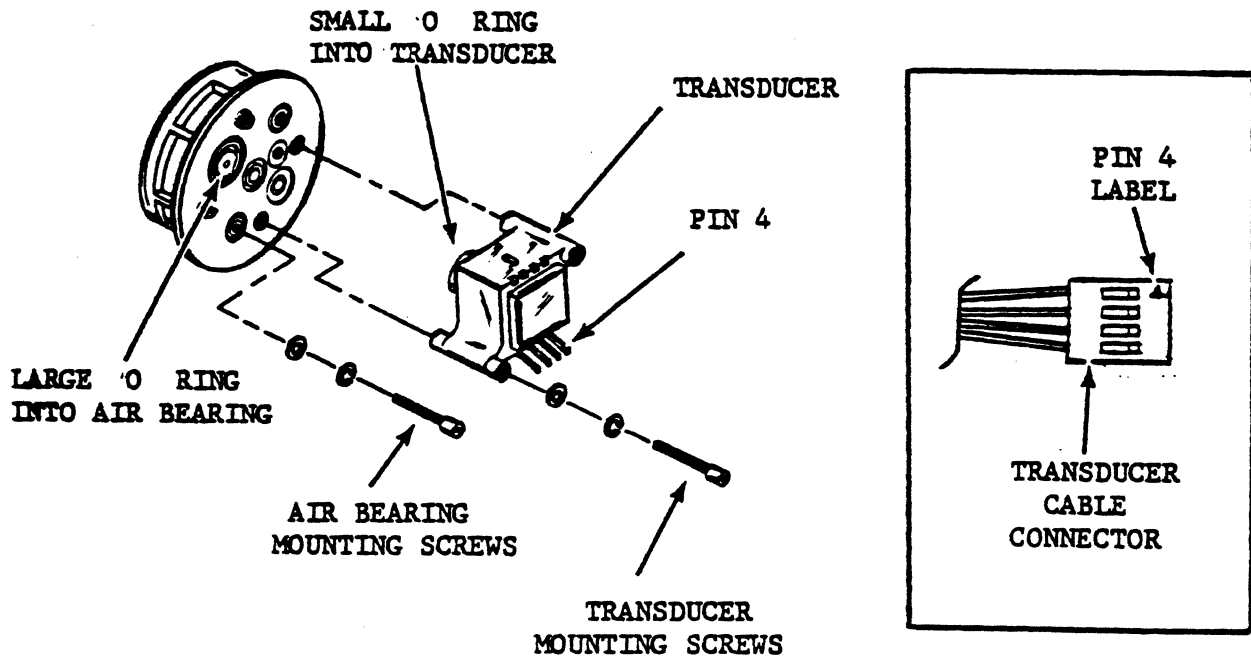

Figure 6-18. Air Bearing Transducers

## AIR BEARING SENSOR REMOVAL/REPLACEMENT

### Removal (Cont'd)

3. Loosen two socket head mounting screws and washers securing the air bearing to the rear of the tape deck with an allen wrench on an extended handle. (The tape path cover on the front of the tape deck will hold the air bearings in place.)
4. From the front of the tape deck, remove the tape path cover and remove the air bearing assembly from the tape deck.
5. Remove the large O ring from the air bearing housing.
6. Remove the two socket head screws and washers securing the transducer to the rear of the air bearing. Remove the transducer and the small O ring from the bearing housing.
7. Replace the upper and lower spring guides as described in the Removal/Replacement Procedure AIR BEARING SPRING GUIDE.

### Replacement

1. Insert a new small O ring in the aperture at the rear of the air bearing housing.
2. Position the transducer on the air bearing so that connector pins are positioned towards the outside of the air bearing. Secure the transducer with mounting screws and washers.
3. Insert a large O ring into the aperture at the rear of the air bearing housing.
4. Place the air bearing assembly onto the tape deck using the locating pin for positioning. Install the tape path covers to hold the air bearing in position.
5. Secure the air bearing to the tape deck with washers and mounting screws. (Use an extended handle allen wrench.)
6. Release the plastic snaps (top and bottom). Release the detents (top and bottom) and slide the formatter card set into the frame. Tighten the card cage lock screws (figure 6-34).
7. Secure the servo/read/write card set to the logic cage with thumbwheel screws (figure 6-31).
8. Re-attach connector P1 to the transducer pins. Refer to figure 6-18 for pin orientation.



## AIR BEARING SENSOR REMOVAL/REPLACEMENT (Cont'd)

### Verification Check

1. With tape threaded, but not loaded, execute operator test 01. If test is successful, test will terminate with display 00. If test fails, refer display number to corresponding fault SAM.



## AIR BEARING SPRING GUIDE REMOVAL/REPLACEMENT

### Removal

#### NOTE

Replacement parts for the air bearing assembly are contained in a refurbishment kit P/N 77015691. This kit contains an upper and lower spring guide, transducer, and a small and large O ring. If a spring guide is being replaced, it is recommended that both upper and lower guides be replaced.

1. Remove tape path and magnetic head covers from tape deck.
2. Remove two phillips head screws securing upper spring guide, isolator, and guard to bearing housing (see figure 6-19).
3. Remove spring guard, isolator, and guide from housing.
4. Repeat steps 2 and 3 to remove lower spring guide.

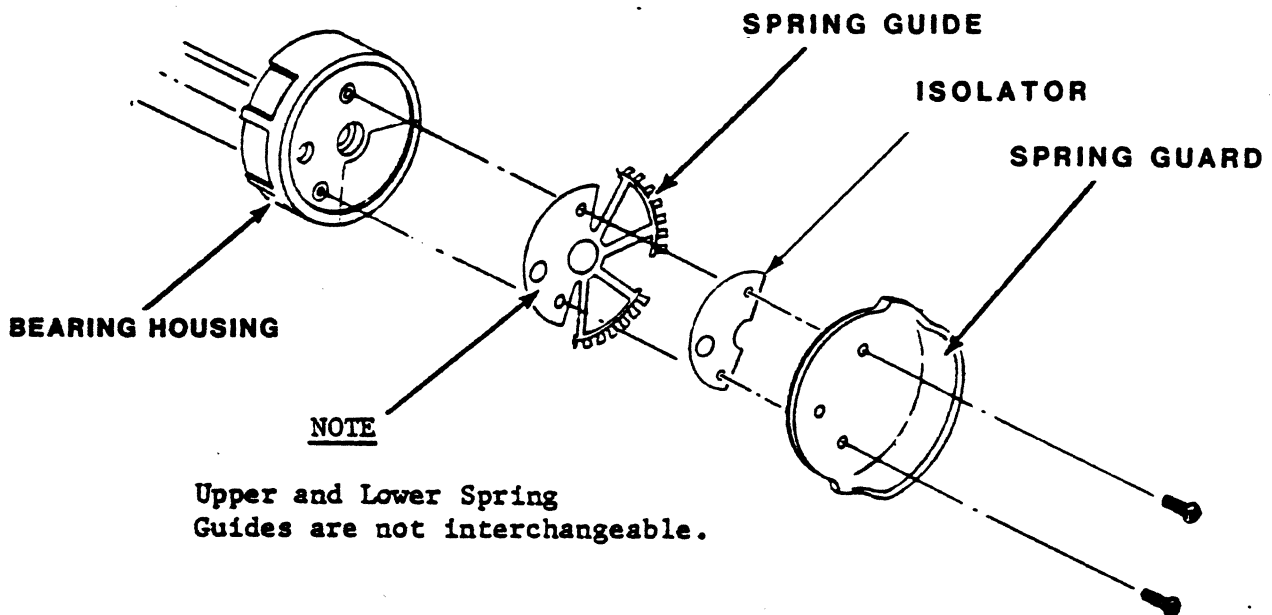

Figure 6-19. Air Bearing Spring Guide

## AIR BEARING SPRING GUIDE REMOVAL/REPLACEMENT(Cont'd)

### Replacement

1. Place new upper spring guide (P/N 77004255), isolator, and guard into bearing housing. Holes for mounting screws provide positive alignment of both piece parts to housing.
2. Secure with two phillips head screws.
3. Repeat steps 1 and 2 using spring guide (P/N 77004254) to replace lower spring guide.
4. Reinstall head covers on tape deck.

### Verification Checks

1. With tape threaded, but no loaded, execute operator test 01. If test is successful, test terminates with display 00. If test fails, refer display number to corresponding fault SAM.
2. Visually observe tape for no tape edge damage.

## COMPRESSOR REMOVAL/REPLACEMENT

### Removal

1. Detach connector W4P4 from the power supply.
2. Remove pneumatic tubing (vacuum and pressure lines) from nipples on air chamber.

### NOTE

Detach any wiring that may interfere with the removal of compressor assembly.

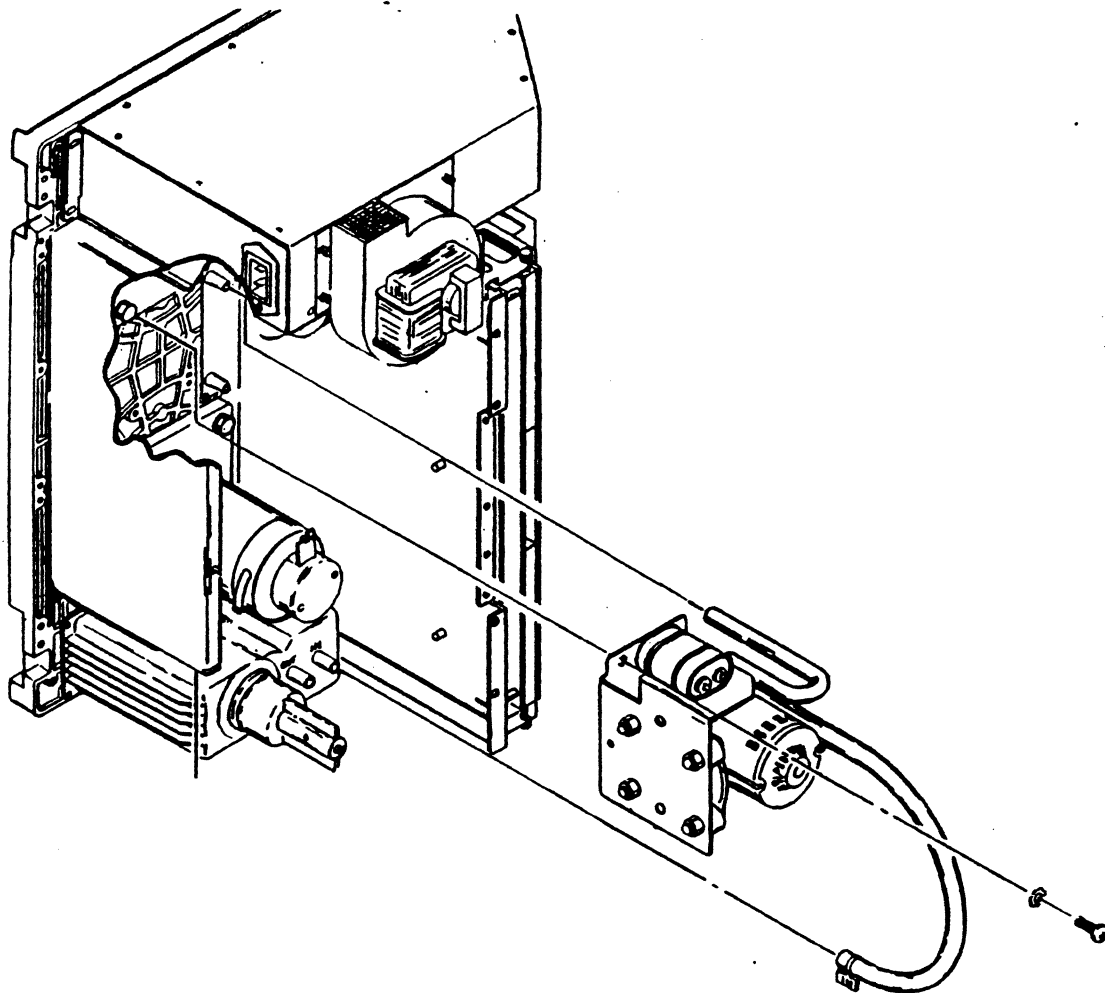

Figure 6-20. Compressor

## COMPRESSOR REMOVAL/REPLACEMENT

### Removal (Cont'd)

3. Remove four mounting screws securing compressor assembly to rear of tape deck. Carefully withdraw assembly from transport.

### Replacement

1. Position compressor assembly to rear of tape deck and secure with washers and mounting screws.
2. Attach pneumatic tubing to nipples on air chamber.
3. Attach connector W4P4 to power supply.

### NOTE

Reattach any wiring that was disconnected prior to the Removal procedure.

### Verification Check

1. Thread tape. Do not load. Execute operator test 01.

## PRESSURE REGULATOR AND FILTER REMOVAL/REPLACEMENT

### NOTE

If only the pressure regulator is being replaced, perform Removal step 1, Replacement step 3, and Verification Check. If filter is being replaced, perform the entire Removal/Replacement and Verification Check procedures.

### Removal

1. Remove the pressure regulator by unscrewing the regulator from the air chamber.
2. Remove the two pneumatic tubes from the IN and OUT nipples on the air chamber.
3. Remove the four mounting screws securing the air chamber and remove the air chamber from the tape deck.
4. Remove the filter from the air chamber.

### Replacement

1. Position the filter into the air chamber.
2. Secure the air chamber to the tape deck with the four mounting screws.
3. Install the two pneumatic tubes on the IN and OUT nipples.
4. Screw the pressure regulator clockwise onto the air chamber assembly.

### Verification Check

1. With tape threaded, but not loaded, execute operator test 01. If test is successful, test will terminate with display 00. If test fails, refer the display number to the corresponding fault SAM.

PRESSURE REGULATOR AND FILTER REMOVAL/REPLACEMENT (Cont'd)

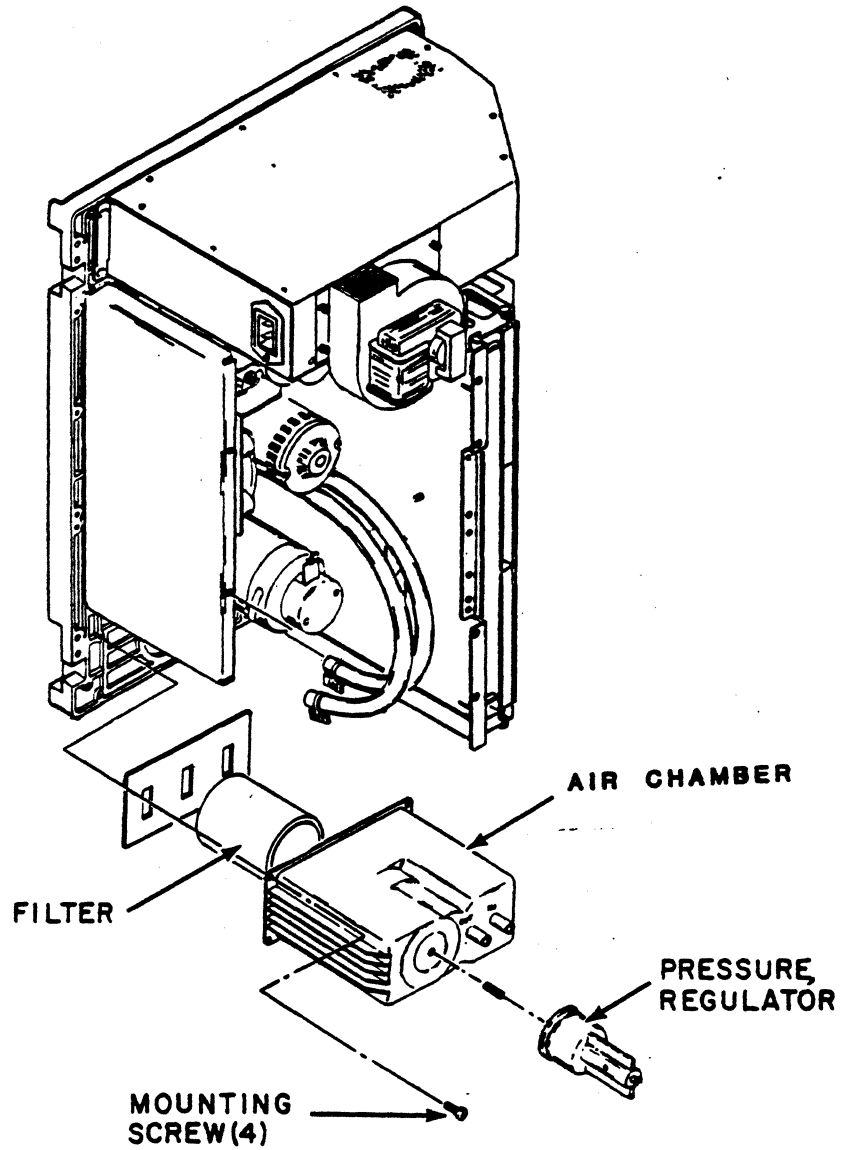

Figure 6-21. Regulator and Filter Removal



## MAGNETIC HEAD REMOVAL/REPLACEMENT

### Removal

1. Remove tape path and magnetic head covers from tape deck.
2. From front of transport, detach read head connector W6P1, write head connector W5P1, and erase head wires P3/P4 from magnetic head (see figure 6-23).

### NOTE

Before removing the head, tape a piece of soft material across recording surface.

3. Loosen top and bottom thumb screws and slide read/write/servo card set out to maintenance position (figure 6-31).

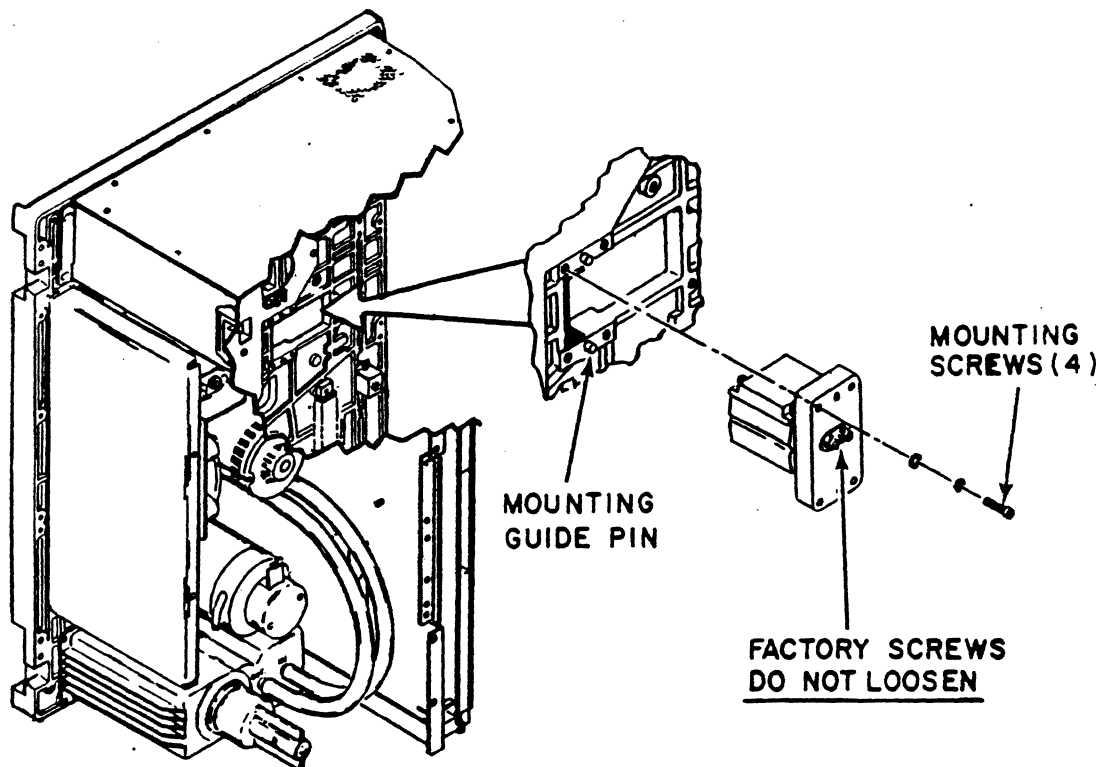

Figure 6-22. Magnetic Head Assembly

## MAGNETIC HEAD REMOVAL/REPLACEMENT (Cont'd)

### CAUTION

Refer to figure 6-22 for location of head mounting screws. DO NOT loosen head assembly screws, otherwise, entire head must be replaced by a new assembly.

4. Loosen four head mounting screws. Hold head against tape deck while removing four mounting screws, lockwashers, and flatwashers.
5. Carefully withdraw head from tape deck.

### Replacement

#### NOTE

Before installing magnetic head, insure that recording surface is protected with soft material.

1. Install magnetic head through tape deck and position mounting surface onto guide pins.
2. While holding head in place, insert flatwashers, lockwashers, and mounting screws. Tighten four mounting screws.
3. Place read and write/erase cables through tape deck.
4. From front of tape deck, attach read, write, and erase connectors to magnetic head (see figure 6-23). Remove recording surface covering.
5. Install tape path and magnetic head covers on tape deck.

# MAGNETIC HEAD REMOVAL/REPLACEMENT (Cont'd)

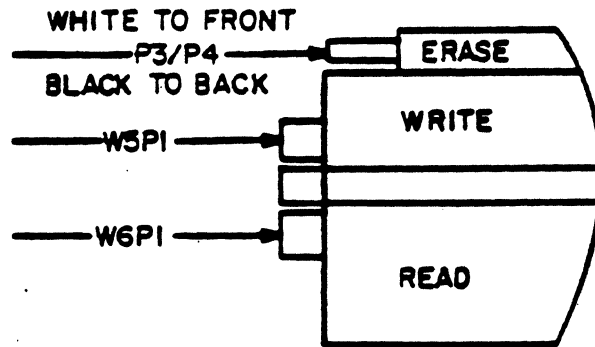

Figure 6-23. Magnetic Head Connectors

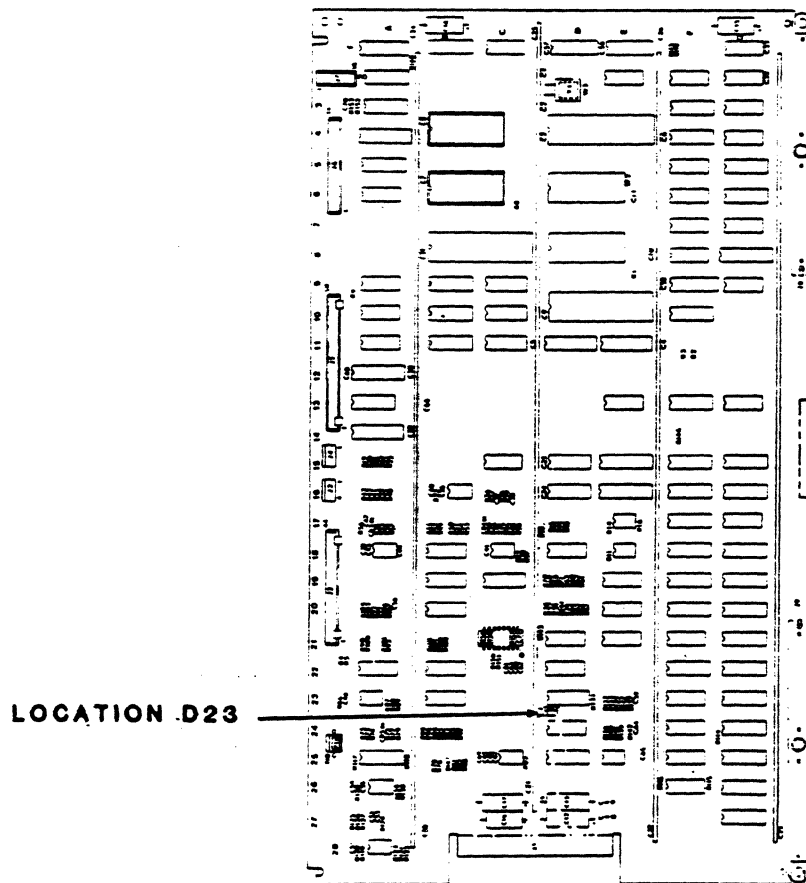

Figure 6-24. Servo-Control PWA

## MAGNETIC HEAD REMOVAL/REPLACEMENT (Cont'd)

### Verification Check

1. Clean magnetic head recording surface with a soft lint-free cloth moistened with tape transport cleaner. Wipe recording surface in same direction as tape motion.
2. Move jumper plug at location D23 on servo-control PWA to the 1-2 position (see figure 6-24).
3. If a write-current label is attached to the magnetic head, execute test 54. If no write-current label is attached to the magnetic head, execute test 64.
4. Load a 3M777, or equivalent, write enabled tape.
5. Execute test 31. Test will complete with display 00.
6. Return jumper plug at location D23 from the 1-2 position to the 2-3 position before unit is powered down.
7. Return read/write/servo card set to operating position. While holding it in place, tighten top and bottom thumb screws to secure card set to card cage (figure 6-31).
8. With tape threaded, but not loaded, execute operator test 01. If test is successful, test will terminate with display 00. If test fails, refer display number to corresponding fault SAM.

## OPERATOR PANEL REMOVAL/REPLACEMENT

### Removal

1. From rear of transport, remove screw securing ground strap to tape deck (E2).
2. Release thumb screws securing PWA to logic cage and swing PWA to access component side of PWA.
3. Detach operator panel cable connector W8P1 from servo-control PWA.
4. Remove cable from clips located on rear of tape deck.
5. From front of transport, slip a small blade screwdriver between operator panel and operator panel housing and pry the operator panel open.
6. Remove operator panel and cable.

### Replacement

1. Insert ground strap, W8 cable and control panel through tape deck and secure with four push-in clips.
2. Attach ground strap to E2 position on tape deck and connect W8P1 to servo-control PWA. Use cable clips on rear of tape deck to secure loose cable.
3. Place PWA in normal operating position and secure to logic cage bracket with top and bottom thumb screws. (Align screws with screw holes before attempting to tighten.)

### Verification Check

1. Perform functional SAM 1001 thru 1003.

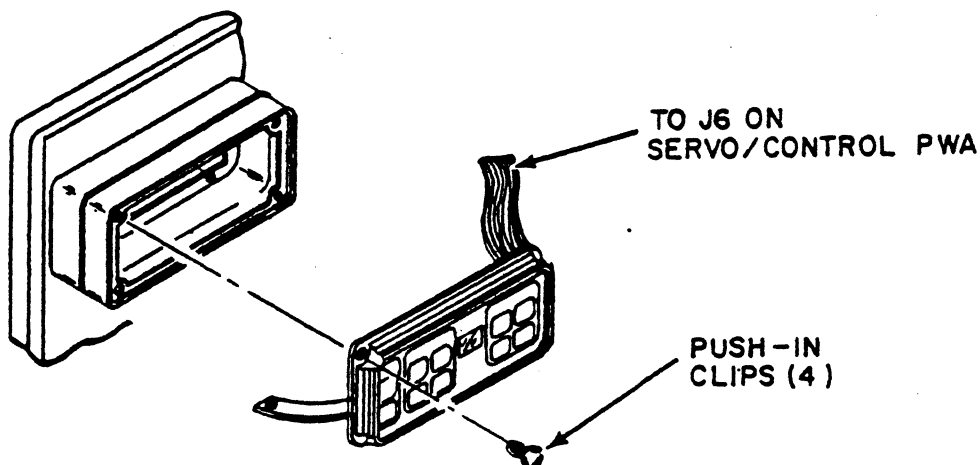

Figure 6-25. Operator Panel Assembly

## COOLING FAN REMOVAL/REPLACEMENT

### Removal

1. Detach cooling fan connector from power supply.
2. Remove four hex nuts and washers and remove the cooling fan from the mounting studs.

### Replacement

1. Perform Removal procedure in reverse order.

### Verification Check

1. Power transport on and check for air flow from fan.

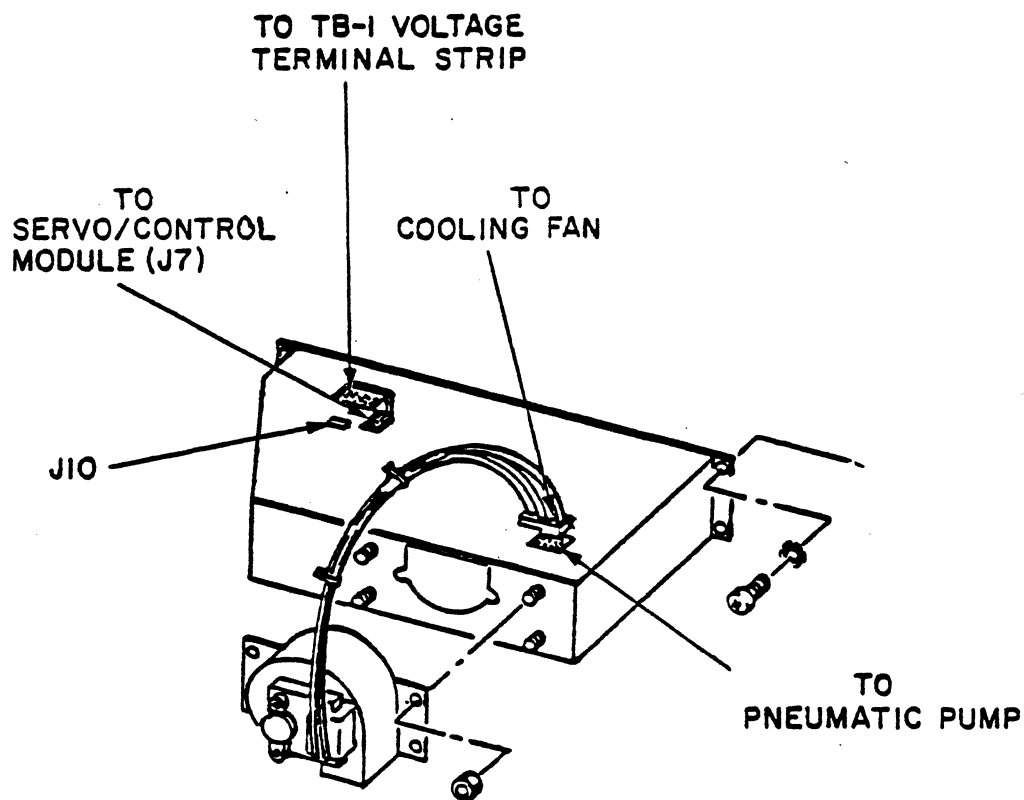

Figure 6-26. Cooling Fan and Power Supply

## POWER SUPPLY REMOVAL/REPLACEMENT

### Removal

1. Disconnect power cord from power supply.
2. Perform cooling fan Removal.
3. Detach connectors from power supply.

### CAUTION

A power supply weighs approximately  
6.8 Kg (15 lbs).

4. While holding power supply in position, remove mounting screws. Lift power supply away from transport.

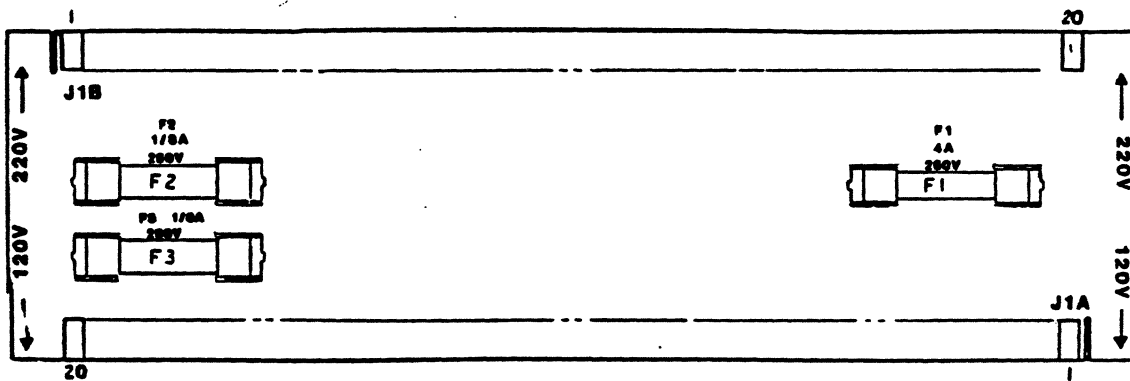

Figure 6-27A. Voltage Select Card  
(7701896X Series Power Supply)

## POWER SUPPLY REMOVAL/REPLACEMENT (Cont'd)

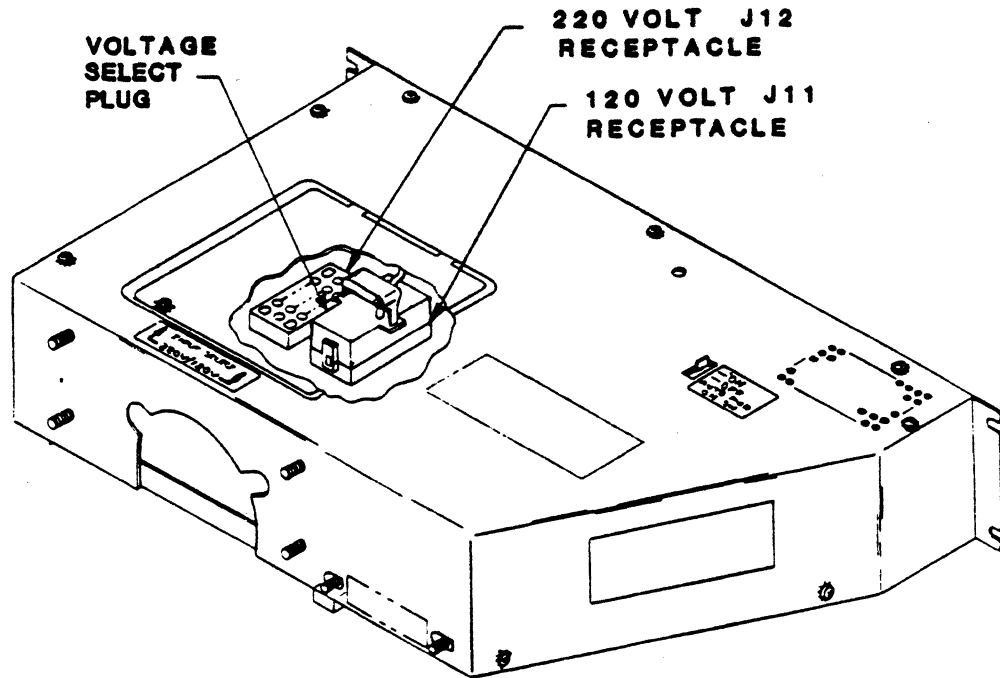

Figure 6-27B. Voltage Select Plug  
(7702934X Series Power Supply)

### Replacement - 7701896X Series Power Supplies

#### NOTE

If a new power supply is being installed, remove cover from new power supply and observe position of voltage select PWA (figure 6-27A). The position of this PWA must correspond to input voltage as defined on equipment identification plate. The ends of the PWA are stencilled with "120V" and "220V" and indicating arrows. Make sure PWA is connected to match input voltage. The PWA can be disconnected, turned upside down, and reconnected to main power supply PWA if required.



## Replacement - 7702934X Series Power Supplies

### NOTE

If a new power supply is being installed, remove voltage select access panel from new power supply and observe position of voltage select plug (figure 6-27B). The position of this plug must correspond to input voltage as defined on equipment identification plate. Make sure plug is inserted in correct voltage receptacle, that is, J11 for 120V operation or J12 for 220-240 operation. Secure voltage select access panel with two screws. Check position of "AUTO POWER-ON SWITCH". Make sure it is in the "OFF" position.

1. With power supply held in position, insert washers and mounting screws and tighten.
2. Attach connectors W4P4, W2P1, and W7P1 to the power supply.
3. Perform cooling fan Replacement procedure.
4. Connect power cord to power supply.

### Verification Check

1. DC Voltage Checks - Using a digital voltmeter for all dc voltage measurements, connect ground lead of meter to pin 4 of power terminal block TB-1 (see figure 6-28). Connect other meter lead to points listed to test all DC voltages.

## DC VOLTAGES AND TOLERANCES

LOCATION	VOLTAGE	TOLERANCE
P1-6*	-6V	$\pm 10\%$ (-5.4 to -6.6)
P1-5*	+5V	+ 2% (+5.00 to +5.10) - 0%
P1-2*	-15V	$\pm 10\%$ (-13.5 to -16.5)
P1-3*	+15V	$\pm 10\%$ (+13.5 to +16.5)
P1-8*	+25V	$\pm 10\%$ (+22.5 to +27.5)
P4-6**	+38V	+ 20% (+45.6 to +34.2) - 10%
J10-2***	-5.2V	$\pm 10\%$ (-4.7 to -5.7)

\* P1 is the power connector on the servo-control PWA.

\*\* P4 is the power connector on the power driver. Servo must be running.

\*\*\* J10 is the 2-pin power connector on the power supply.

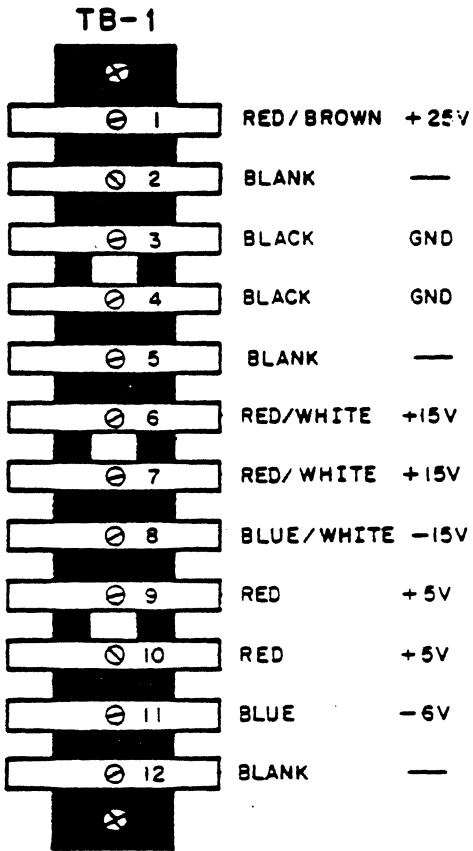

Figure 6-28. Power Terminal Strip TB-1

## CAPACITOR REMOVAL/REPLACEMENT

### Removal

1. Remove drive cover.
2. Remove capacitor connector from J5 of the power driver PWA.
3. Insert a screwdriver through the access hole and loosen the screw holding the capacitor in the retainer. Remove the capacitor from the retainer (see figure 6-29).

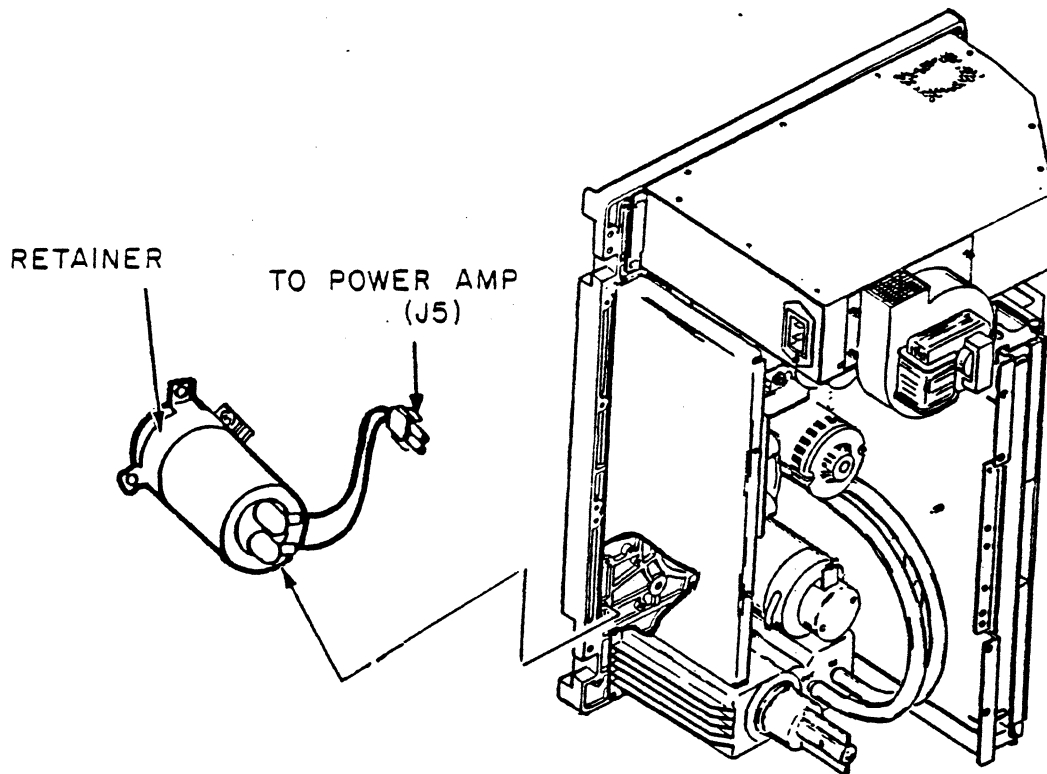

Figure 6-29. Capacitor

## CAPACITOR REMOVAL/REPLACEMENT

### Removal (Cont'd)

#### NOTE

The capacitor loses its charge within four seconds after transport power is removed.

### Replacement

1. Install the connector wires to the same capacitor terminal location as the original. Slide the protective caps over the terminals.
2. Place the capacitor in the retainer. Insert a screwdriver through the access hole and tighten the retainer screw until the capacitor is secured.
3. Install the capacitor connector in J5 of the power driver module.
4. Replace the drive cover.

### Verification Check

1. Thread tape. Do not load. Execute operator diagnostic test 01.

## WRITE DRIVER REMOVAL/REPLACEMENT

### Removal

1. Remove connectors W7P6, W5P2, and W12P1 (see figure 6-30).
2. Remove four pan head screws holding the write driver PWA to the plastic standoffs and remove write driver PWA.

### Replacement

1. Mount the write driver PWA on the plastic standoff using four pan head screws.
2. Install connectors:

J4 - W5P2  
J6 - W12P1  
J7 - W7P6

### NOTE

It may be necessary to turn connector W7P6 over to mate the W7P6 contacts with the J7 contacts. Due to a change in the write driver printed wiring board, the contact points of J7 were moved from the foil side of the board to the component side. Connector W7P6 may be used with either PWB; make a visual check to be sure that W7P6 is properly oriented with respect to the contacts of J7.

### Verification Check

1. Load a 3M777, or equivalent, write enabled tape.
2. Move the jumper plug at location D23 on servo-control PWA to the 1-2 position.
3. Execute test 64. If test is successful, test will terminate with display 00. If test fails, refer display number to test description in test 64.
4. After test is complete (display 00), return the jumper plug to the 2-3 position before powering down.
5. With tape threaded, but not loaded, execute operator test 01. If test is successful, test will terminate with display 00. If test fails, refer display number to corresponding fault SAM.

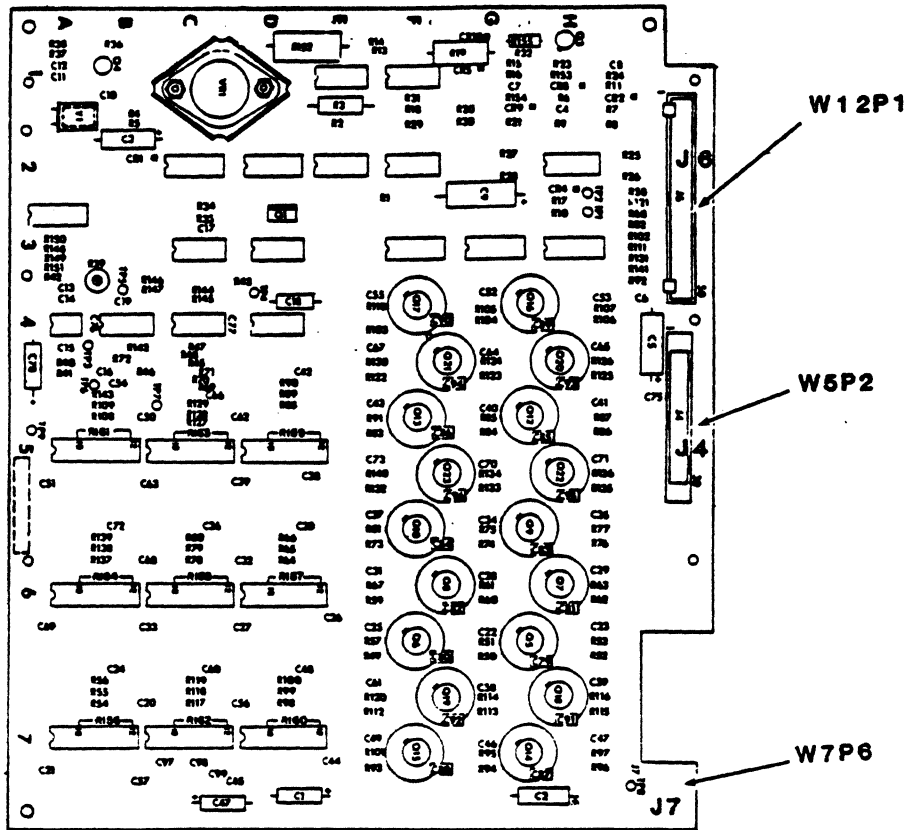

Figure 6-30. Write Driver PWA Connectors

## READ AMPLIFIER REMOVAL/REPLACEMENT

### Removal

1. Perform the write driver PWA Removal procedure.
2. Loosen the top and bottom thumb screws securing the servo/read/write card set to the card cage (figure 6-31).
3. Slide out and reposition card set to maintenance position. Remove yellow fastener clips from top and bottom of card set (figure 6-31).
4. Remove connectors W6P2, W7P4, W7P5, W12P2, and W12P3 from Read Amplifier PWA (see figure 6-32).
5. Loosen the two thumb screws (figure 6-34) and separate the Read Amplifier PWA from the Servo Control PWA. Avoid undue stress on the PWA by loosening the thumb screws alternately and separating the PWAs as the screws are loosened.
6. Loosen and back out only the bottom screws (see figure 6-34) of each hinge 6 to 8 turns. Loosen the top screws one-half turn (Do Not remove). Hold the PWA in place while loosening the screws.
7. Remove the read amplifier PWA from the card set.

### Replacement

1. Insert the PWA into the slots in the top and bottom hinges of the card set. Make sure the PWA is fully inserted into the hinge slot.
2. Attach the outside pin connectors of both PWAs and secure with the two thumb screws.
3. Insert the bottom screw of top and bottom hinges to lock the PWA into position. Make sure all four hinge screws are snug.
4. Install connectors to the PWA as follows:
  - J1 - W7P4
  - J5 - W6P2
  - J6 - W12P2
  - J8 - W7P5
  - J9 - W12P3
5. Perform the write driver Replacement procedure.
6. Reinstall yellow fastener clips on top and bottom of card set (figure 6-31).



## READ AMPLIFIER REMOVAL/REPLACEMENT (Cont'd)

### Verification Check

1. Load a 3M777, or equivalent, write enabled tape.
2. Move jumper at location D23 on servo-control PWA to the 1-2 position.
3. Execute test 31. If test is successful, test will terminate with display 00. If test fails, refer display number to test description for test 31.
4. After test is complete (display 00), return jumper plug to the 2-3 position before powering down.
5. Return read/write/servo card set to operating position. While holding it in place, tighten top and bottom thumb screws to secure card set to card cage (figure 6-31).
6. With tape threaded, but not loaded, execute operator test 01. If test is successful, test will terminate with display 00. If test fails, refer display number to corresponding fault SAM.

1. BACK OUT TOP SCREW (TOP & BOTTOM HINGES) TO REMOVE SERVO/CONTROL PWA.
2. BACK OUT LOWER SCREW (TOP & BOTTOM HINGES) TO REMOVE READ AMP. PWA.

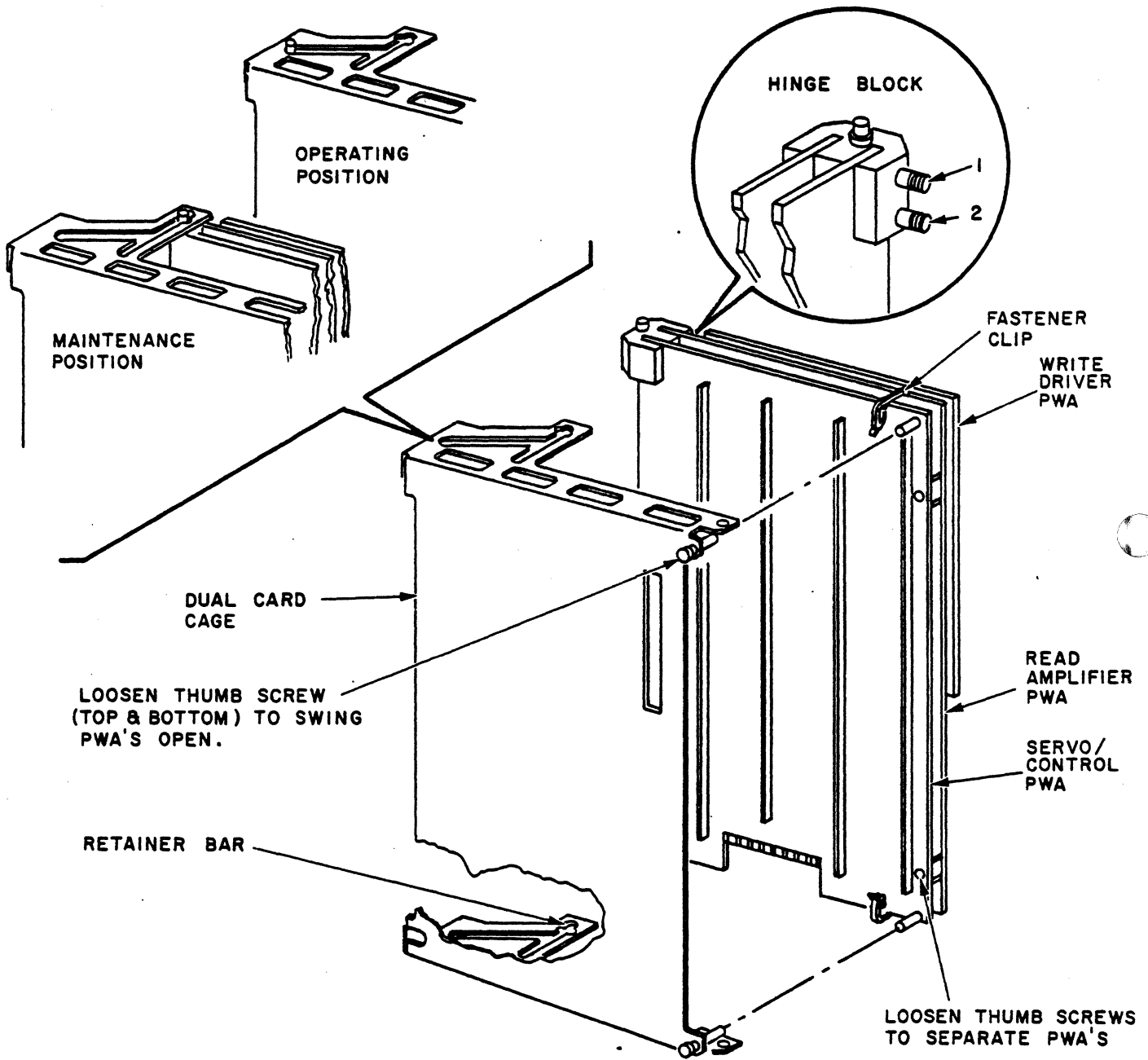

Figure 6-31. Write Driver/Read Amp/Servo-Control PWAs

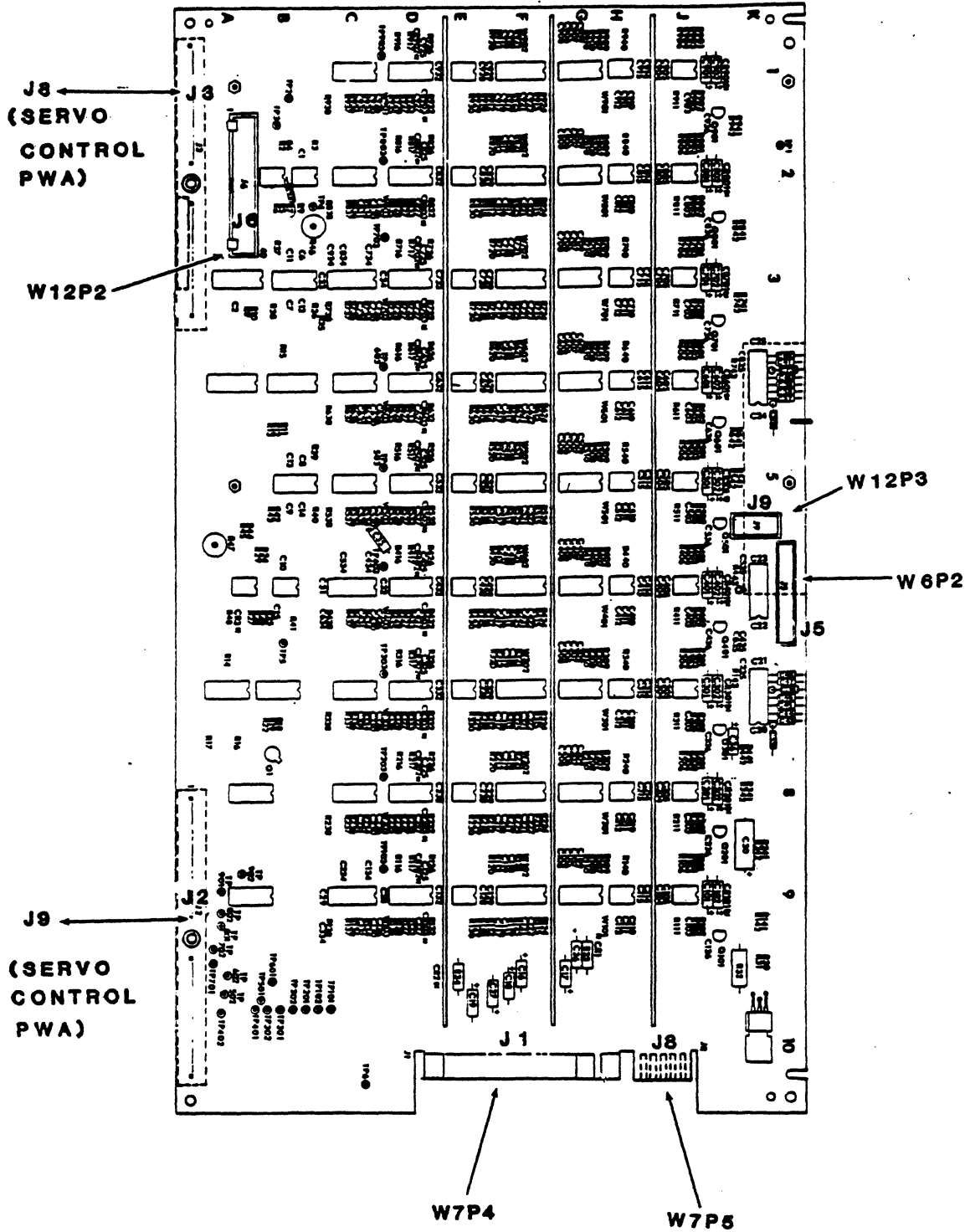

Figure 6-32. Read Amplifier PWA Connectors

## SERVO-CONTROL REMOVAL/REPLACEMENT

### NOTE

Replacement of the servo-control PWA requires execution of the following set-up tests:

Test 37 Set Up Velocity Correction Multipliers  
Test 48 Enable Compressor Power-Down Timer  
Test 84 Select/Examine STU Options (buffered enhanced I/F only)  
Test 64 Auto-Write Current Level Adjustment  
Test 31 Set Up and Check Read Amplitudes at 25 and 7.5 ips

Execution of test 37 affects the tests 81 and 84 as follows:

Test 81 (Select Early EOT Point) is set to 50 feet. Test 84 (Select/Examine STU Options) - The EEPROM is initialized and all display bits cleared to 0.

In order to return the STU to service with original option selection intact, it is necessary to perform step 1 of the removal procedure and steps 4 and 11 of the verification check.

### Removal

1. Determine and record the option selections set by tests 81 and 84.
2. Loosen the top and bottom thumb screws securing the servo/read/write/card set to the card cage.
3. Slide card set out to maintenance position. Remove yellow fastener clips from top and bottom of card set (figure 6-31).
4. Disconnect connectors W2P1, W8P1, W10P1, W1P2, W9P2, W7P4, and W3P8 from servo-control PWA (see figure 6-33).
5. Loosen the two thumb screws (figure 6-31) and separate the servo-control PWA from the read amplifier PWA. Avoid undue stress on the PWA by loosening the thumb screws alternately and separating the PWA as the screws are loosened.
6. Loosen and back out only the top screws (see figure 6-31) of each hinge. Loosen the bottom screws one-half turn (do not remove). Hold the PWA in place while loosening the screws.

## SERVO-CONTROL REMOVAL/REPLACEMENT (Cont'd)

### Replacement

1. Insert the PWA into the slots in the top and bottom hinges of the card set. Make sure the PWA is fully inserted into the hinge slot.
2. Attach the outside pin connectors of both PWAs and secure with the two thumb screws.
3. Insert the top screw of the top and bottom hinges to lock the PWA into position. Make sure all four hinge screws are snug.
4. Install connectors to the PWA as follows:

J2-W3P8  
J3-W9P2  
J4-W1P2  
J5-W10P1  
J6-W8P1  
J7-W2P1  
J1-W7P4

#### NOTE

If connectors J3/W9P1 and J4/W1P1 are not keyed, insert the connectors so that pins 1, 2, 3 and 4 of W9P1 mate with pins 4, 3, 2 and 1 respectively of J3, and pins 1, 2, 3 and 4 of W1P1 mate with pins 4, 3, 2 and 1 respectively of J4.

5. Reinstall yellow fastener clips on top and bottom of card set (figure 6-31).

## SERVO-CONTROL REMOVAL/REPLACEMENT (Cont'd)

### Verification Check

1. Move jumper plug at location D23 on servo-control PWA to the 1-2 position.
2. With tape not threaded, execute test 37. If test is successful, test will terminate with display 00. If test fails, refer display number to test description for test 37.
3. With tape not threaded, execute test 48. If test is successful, test will terminate with display 00. If test fails, refer display number to test description for test 48.
4. Refer to the option selection recorded in step 1 of the Removal procedure. Execute test 84 as necessary to restore the original option selection.
5. Load a 3M777, or equivalent, write enabled tape.
6. Execute test 64. If test is successful, test will terminate with display 00. If test fails, refer display number to test description for test 64.
7. Execute test 31. If test is successful, test will terminate with display 00. If test fails, refer display number to test description for test 31.
8. After test is complete (display 00), return jumper plug to the 2-3 position before powering down.
9. Return read/write/servo card set to operating position. While holding it in place, tighten top and bottom thumb screws to secure card set to card cage.
10. Refer to the option selections recorded in step 1 of the Removal procedure. Execute test 81 as necessary to restore the original option selection.
11. With tape threaded, but not loaded, execute operator test 01. If test is successful, test will terminate with display 00. If test fails, refer display number to corresponding fault SAM.

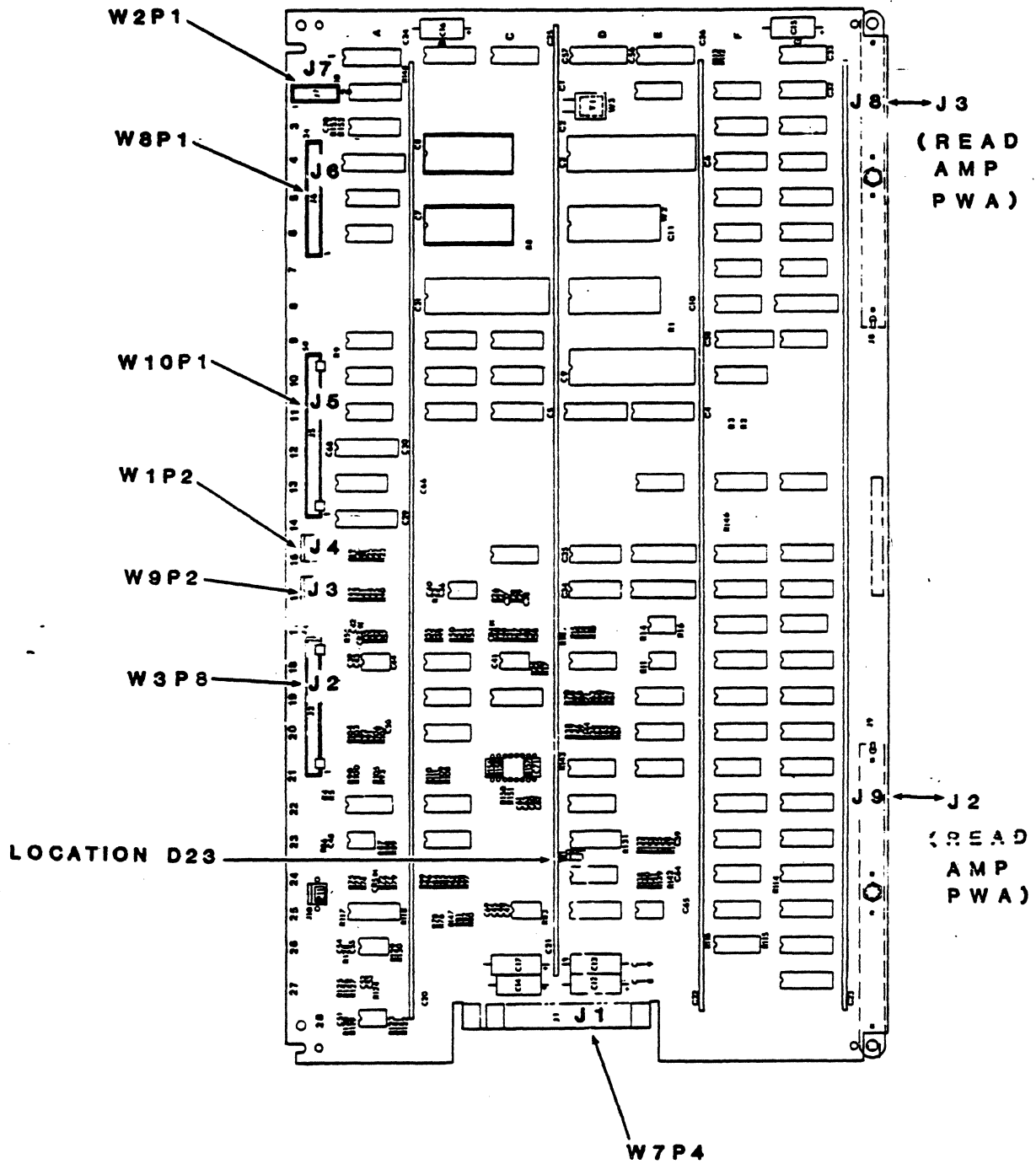

Figure 6-33. Servo-Control PWA Connectors





## FORMATTER READ REMOVAL/REPLACEMENT

### Removal

1. Loosen top and bottom thumb screws and slide card set out until detents in top and bottom slide brackets engage with front of card cage. Pull card set out further until plastic snaps on card hinges engage with front of slide brackets (figure 6-34).
2. Remove yellow fastener clips from top and bottom of formatter card set (figure 6-34).
3. Loosen the two thumb screws (figure 6-34) to separate the formatter read PWA from the formatter write PWA. Avoid undue stress on the on-board pin connectors J2 and J3 by loosening the thumb screws alternately and separating the PWAs as the screws are loosened. See figure 6-36.
4. Loosen and back out 6 to 8 turns the bottom screws (see figure 6-34) of each hinge. Loosen top screws one-half turn (do not remove). Hold PWA in place while loosening screws.
5. Disconnect the formatter read PWA from the DC power connector W7P3 and remove the PWA from the card set.

### Replacement

1. Insert PWA into slots in top and bottom hinges into DC power connector W7P8. Make sure W7P8 is snug on both PWAs.
2. Attach the on-board pin connectors J2 and J3 of both PWAs by squeezing top corners of the two PWAs and then tightening the top thumb screws. Repeat for the lower corner.
3. Insert the bottom screw of top and bottom hinges to lock the PWA into position. Make sure all four hinge screws are snug.
4. Reinstall yellow fastener clips on top and bottom of formatter card set (figure 6-34).
5. Depress plastic snaps on top and bottom hinges of card set and slide card set in three inches. Release detents in top and bottom slide brackets and slide card set back into card cage. Tighten top and bottom thumb screws to card cage (figure 6-34).

### Verification Check

1. With tape threaded, but not loaded, execute operator test 01. If test is successful, test will terminate with display 00. If test fails, refer display number to corresponding fault SAM.

1. RELEASE PLASTIC SNAP TOP AND BOTTOM
2. PUSH IN THEN RELEASE METAL SNAP TOP AND BOTTOM.
3. RESUME PUSH.

1. BACK OUT SCREWS (TOP & BOTTOM) TO REMOVE INTERFACE PWA.
2. BACK OUT SCREWS (TOP & BOTTOM) TO REMOVE FORMATTER READ PWA.
3. BACK OUT SCREWS (TOP & BOTTOM) TO REMOVE FORMATTER WRITE PWA.
4. TAB MUST BE DEPRESSED TO REINSERT PWA SET.

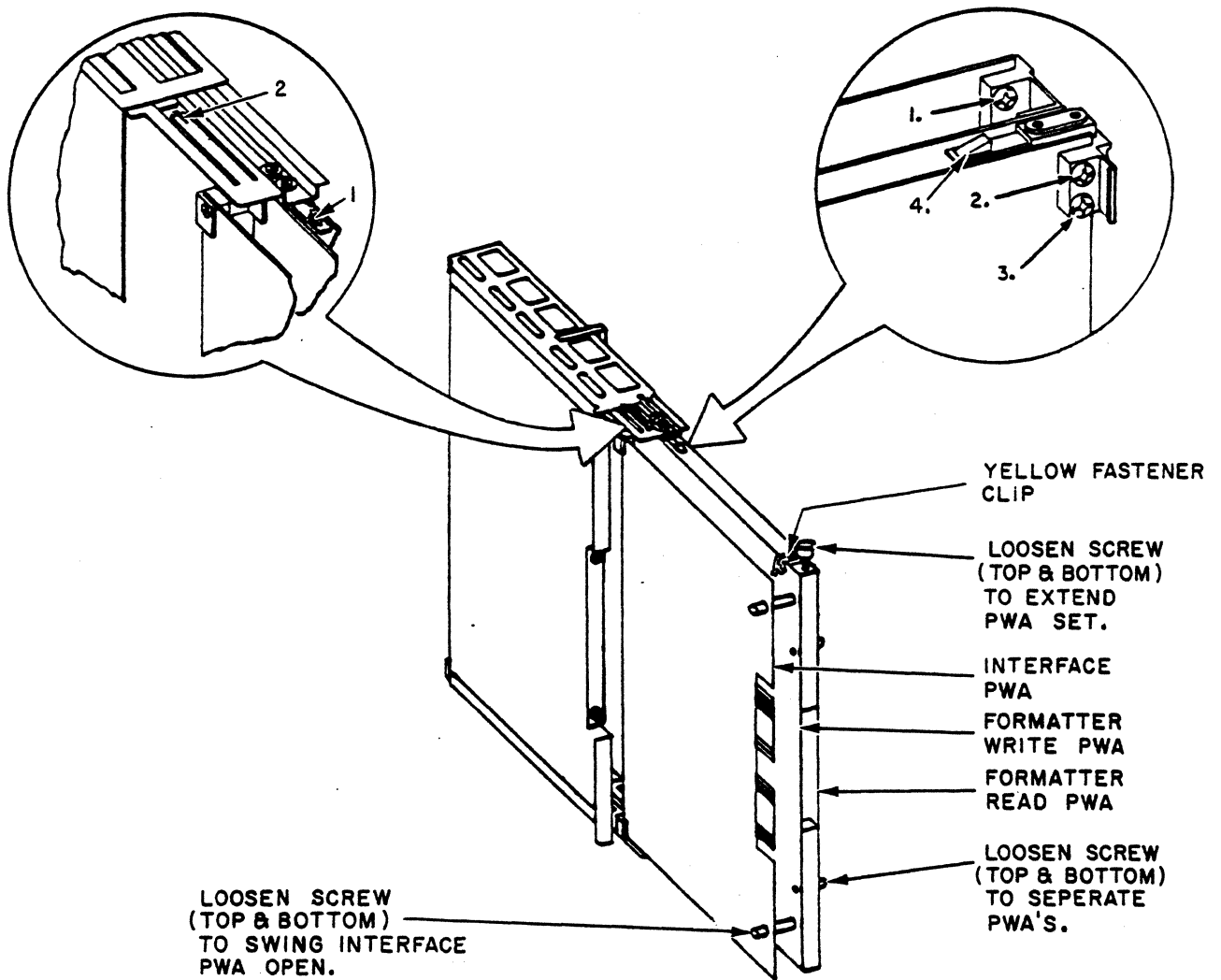
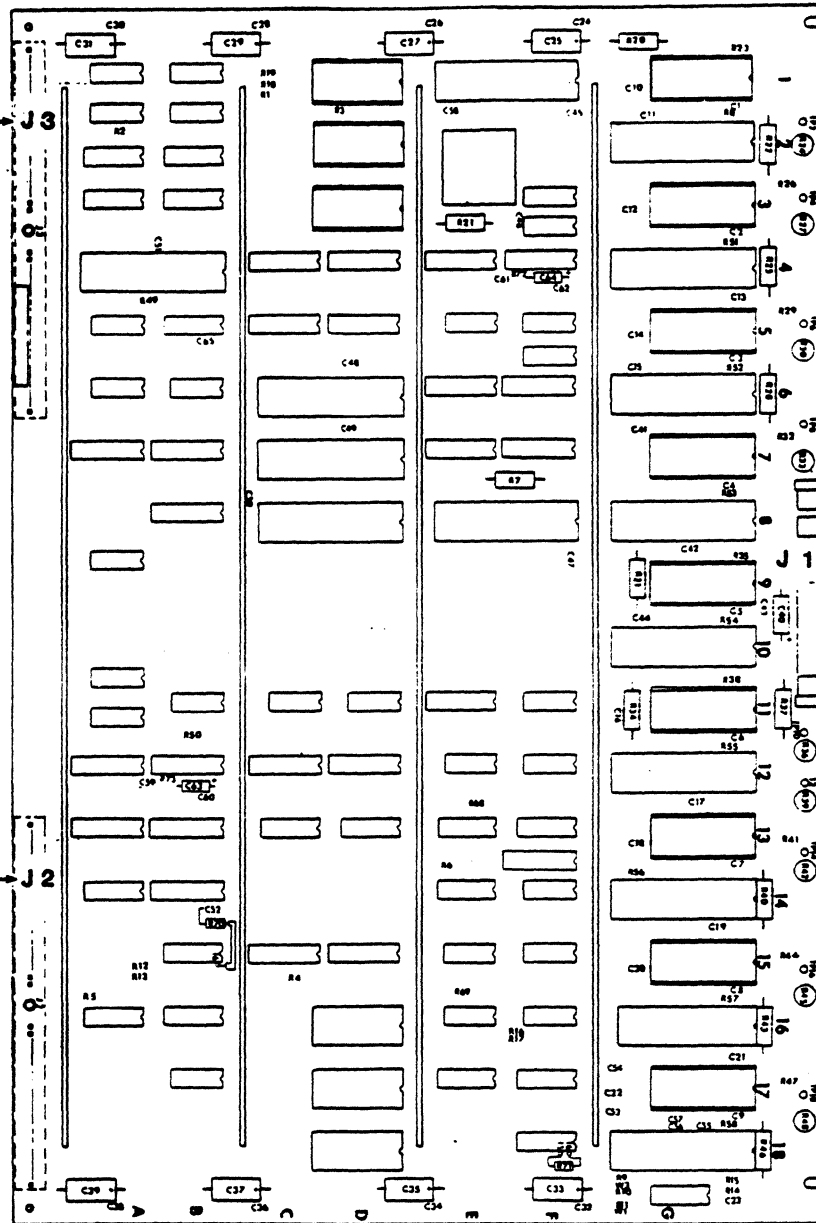

Figure 6-34. Formatter Read/Write/Interface PWA's

J2  
(FORMATTER  
WRITE PWA)

J3  
(FORMATTER  
WRITE PWA)



W 7 P 8

Figure 6-35. Formatter Read PWA Connectors

## FORMATTER WRITE REMOVAL/REPLACEMENT

### Removal

1. Loosen top and bottom thumb screws and slide card set out until detents in top and bottom slide brackets engage with front of card cage. Pull card set out further until plastic snaps on card set hinges engage with front of slide brackets (figure 6-34).
2. Remove yellow fastener clips from top and bottom of formatter card set (figure 6-34).
3. Unscrew top and bottom thumb screws (figure 6-34) securing interface PWA to the formatter write PWA.
4. Remove connectors W10P2 and W11P1 from the PWA (figure 6-36).
5. Loosen the two thumb screws (figure 6-34) to separate the formatter read PWA from the formatter write PWA. Avoid undue stress on the PWA by loosening the thumb screws alternately and separating the PWAs as screws are loosened.
6. Loosen and back out only the top screws (see figure 6-34) of each hinge. Loosen the bottom screws one-half turn (do not remove). Hold the PWA in place while loosening the screws.
7. Disconnect the formatter write PWA from the DC power connector W7P8 and remove the PWA from the card set.

### Replacement

#### NOTE

Before installing the new PWA, ensure that the jumper blocks (W1, W2, W3) at PWA locations A1 and B1 are in the same position as on the replaced PWA.

1. Insert the PWA into the slots in the top and bottom hinges and into the DC power connector W7P8. Make sure W7P8 is snug on both PWAs.
2. Attach the outside pin connectors of both PWAs and secure with the two thumb screws.
3. Insert the bottom screw of the top and bottom hinges to lock PWA into position. Make sure all four hinge screws are snug.

## FORMATTER WRITE REMOVAL/REPLACEMENT

### Replacement (Cont'd)

4. Attach connectors W10P2 to J5 and W11P1 to J4 on the PWA.
5. Secure the formatter write PWA to the formatter read PWA, and the interface PWA to the formatter write PWA by using the thumb screws (figure 6-34).
6. Reinstall yellow fastener clips on top and bottom of formatter card set (figure 6-34).
7. Depress the plastic snaps on the top and bottom hinges of the card set and slide the card set in three inches. Release the detents in the top and bottom slide brackets and slide the card set back into the card cage. Tighten the top and bottom thumb screws to the card cage (figure 6-34).

### Verification Check

1. With tape threaded, but not loaded, execute operator test 01. If test is successful, test will terminate with display 00. If test fails, refer display number to corresponding fault SAM.

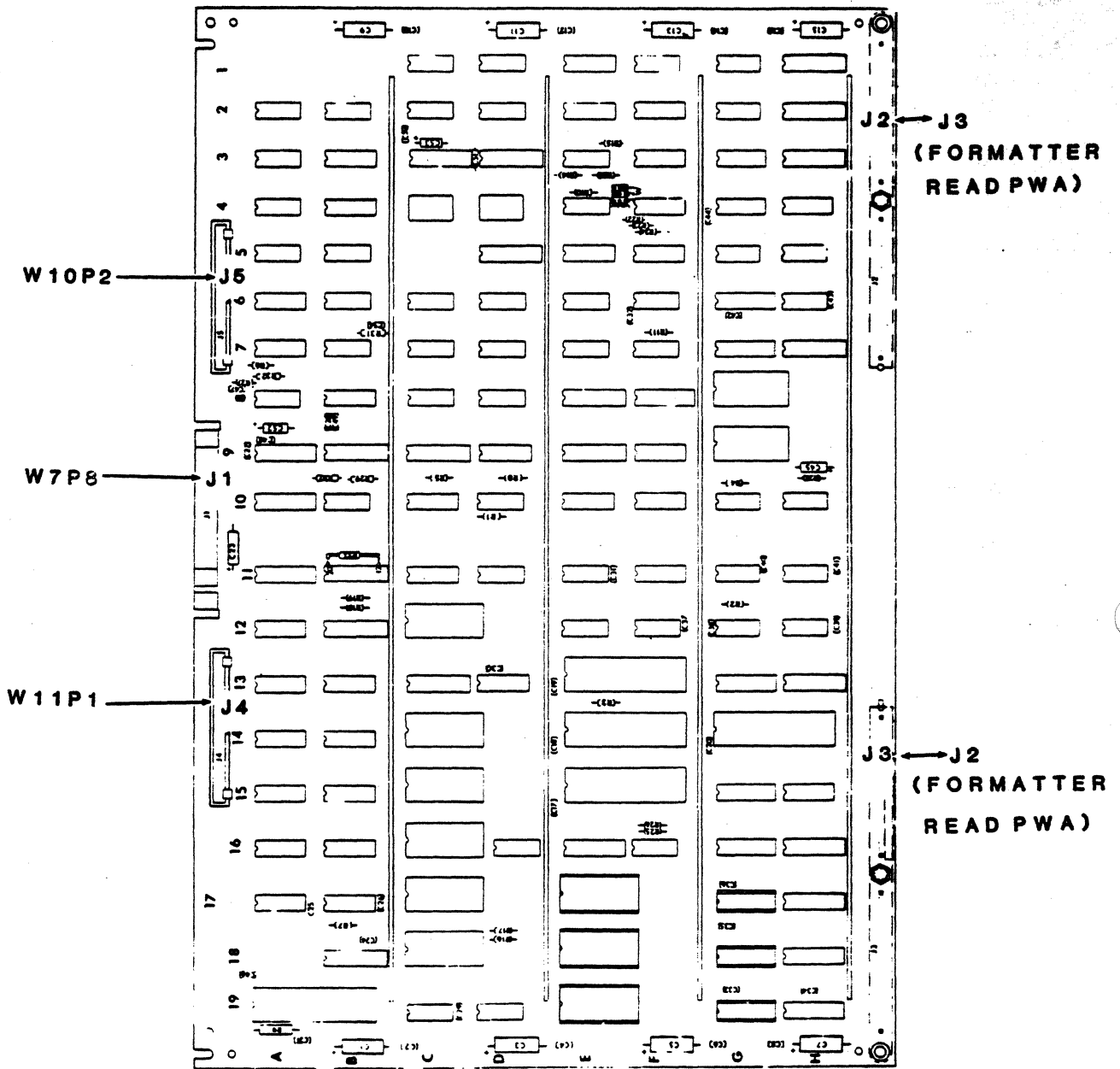

Figure 6-36. Formatter Write PWA Connectors

## INTERFACE REMOVAL/REPLACEMENT

### Removal

1. Loosen top and bottom thumb screws and slide card set out until detents in top and bottom slide brackets engage with front of card cage. Pull formatter card set out further with plastic snaps on card set hinges engage with front of slide brackets (figure 6-34).
2. Unscrew upper and lower thumb screws (figure 6-34) securing the interface PWA to the formatter write PWA.
3. Disconnect connectors W7P9 and I/O cables at J2 and J3 from the interface PWA. Disconnect connector W11P1 from J4 on the formatter write PWA (figure 6-37).
4. Remove the top and bottom screws from the hinges (figure 6-34) and remove the PWA from the card set.

### NOTE

Before installing new interface PWA, ensure jumpers and switches are in same position as those in replaced PWA.

### Replacement

1. Insert PWA in upper and lower hinges and secure with two screws.
2. Install cable connectors as follows:  
W7P9 - J1  
W11P1 - J4 on formatter write PWA
3. Tighten upper and lower thumb screws to secure the interface PWA to the formatter write PWA.
4. Depress plastic snaps on top and bottom hinges of formatter card set and slide card set in three inches. Release detents in top and bottom slide brackets and slide card set back into card cage. Tighten top and bottom thumb screws to card cage (figure 6-34).
5. Reconnect I/O cables.

### Verification Check

1. Apply dc power to the drive to execute the Interface Health Check. If check is successful, check will terminate with display 00. If test fails, refer display number to corresponding fault SAM.

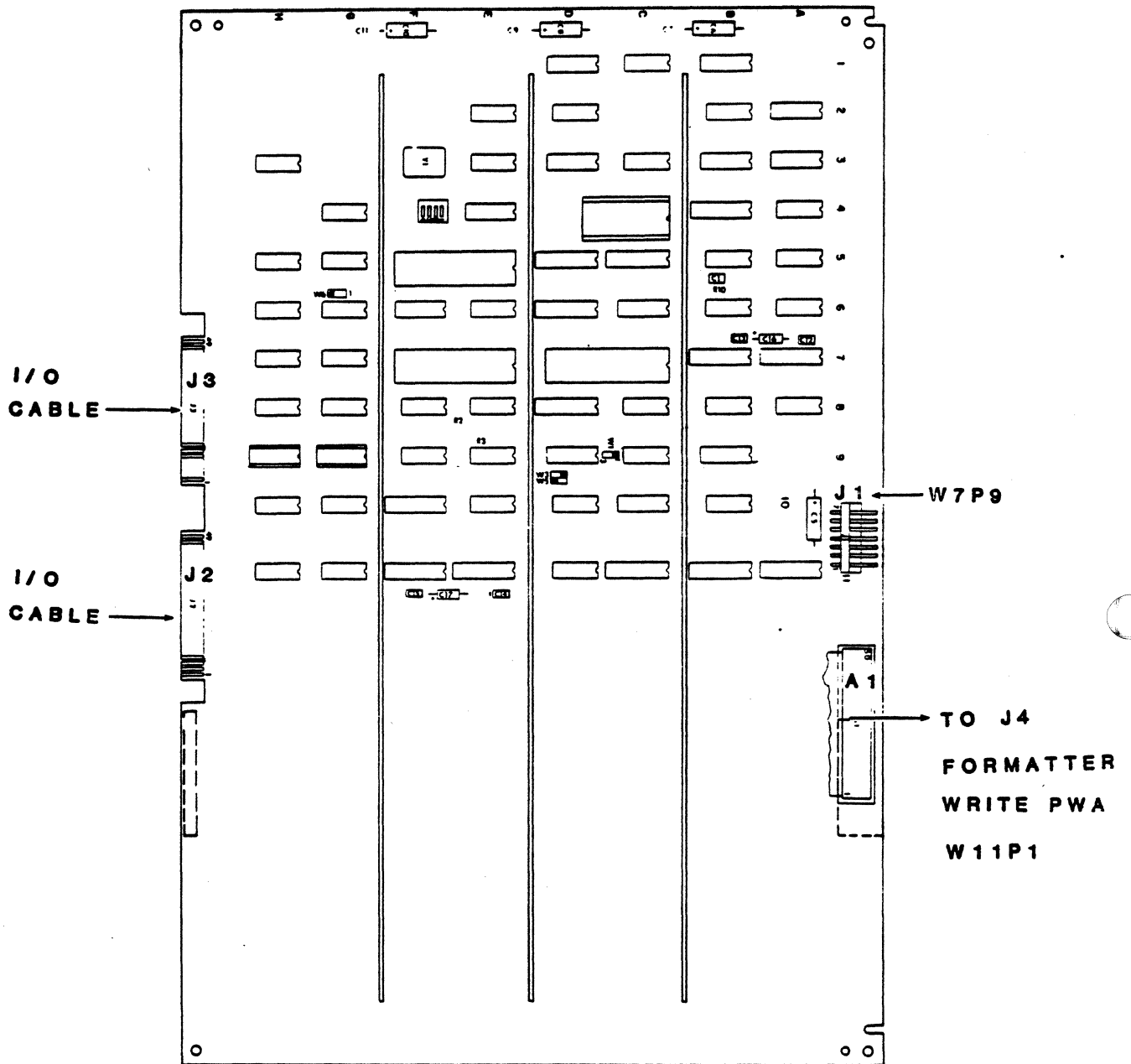

Figure 6-37. Interface PWA Connectors



## POWER DRIVER REMOVAL/REPLACEMENT

### Removal

1. Detach the following connectors from power driver PWA (see figure 6-38):
  - J1 - B3P1
  - J2 - W3P7
  - J3 - B1P1
  - J4 - W7P2
2. Remove power driver cover by removing two screws.
3. Remove three screws along outside edge of PWA to release PWA from mounting assembly. Remove PWA.

### Replacement

1. Insert power driver PWA into mounting assembly. The inside of mounting assembly has metal slots to receive PWA.
2. Secure PWA by installing three screws along outside edge.
3. Install cover assembly and secure with two pan head phillips locking screws.
4. Install connectors as follows:
  - J1 - B3P1
  - J2 - W3P7
  - J3 - B1P1
  - J4 - W7P2

### Verification Check

1. With tape threaded, but not loaded, execute operator test 01. If test is successful, test will terminate with display 00. If test fails, refer display number to corresponding fault SAM.

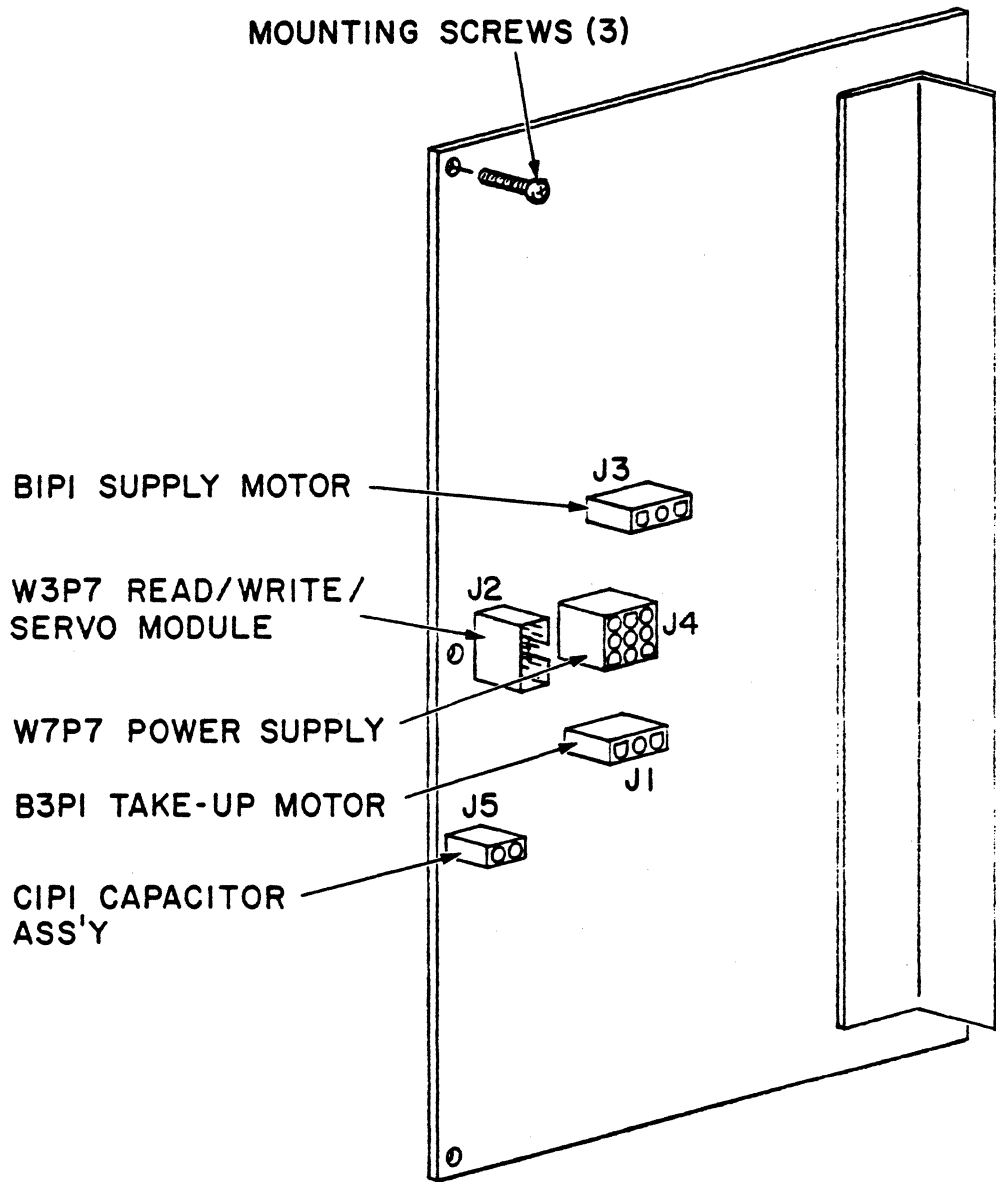

Figure 6-38. Power Driver Connectors

---

## PARTS DATA

- A. FORMAT - A general understanding of this manual is necessary for efficient use in identifying parts and obtaining part numbers.
1. Locators are provided to aid in the location of an assembly and the figure in which it is illustrated. Isometric illustrations are provided for every major assembly and subassembly of the tape transport.

B. EXPLANATION OF TERMS AS USED IN THE PARTS LIST (See Example)

1. The number before the hyphen is the figure to which it applies. The number after the hyphen is the callout number on the figure.
2. The 8-digit number is the identifying number used in ordering replaceable parts.
3. INDENTURES - This indicates the relationship of parts to the next higher assembly.

EXAMPLE: Guard, Spring Guide, Upper, Item -1, 1 dot, is part of the Air Bearing Assembly, Item 4-.

4. ATTACHING PARTS - The attaching parts for a particular part or assembly.
5. The part code refers to the ordering of parts and is to be read as follows:

\* = Authorized Field Replacement Part. Item is available on a routine order or an emergency order if justified.

CNS = Cataloged Not Stocked. Item is in stock only at original manufacturing division or outside vendor.

PARTS DATA (Cont'd)

In an emergency:

- a. Order next higher assembly that contains item from WDC; that assembly must be coded with an asterisk(\*).
- b. Do not order any CNS items on an emergency order.

In routine cases:

- a. Order the item on a routine order from WDC.
- b. Expect delivery of the item in 4 to 26 weeks.

NC = Not Cataloged. Item is only available as follows:

For assembly-type items (routine or emergency):

Always order the next higher assembly that contains the item; that assembly must be coded with an asterisk (\*).

All parts must be ordered from STPWDC (World Distribution Center)  
(612) 292-2200:  
Control Data Corp., 304 North Dale Street, St. Paul, MN, 55103

EXAMPLE

<u>INDEX</u> <u>NO.</u>	<u>PART</u> <u>CODE</u>	<u>PART</u> <u>NUMBER</u>	1	2	3	4	5	6	DESCRIPTION
8-	CNS	77004215							AIR BEARING ASSEMBLY - UPPER
-1	NC	77005020							. GUARD, SPRING GUIDE UPPER
-2	NOTE	77004255							. GUARD, - TAPE, SPRING AIR BEARING -attaching parts-
-3	NC	92748082							. SCREW, MACH PAN HD PHL, 4-40 x .250 -----*-----
-4	NC	77004241							. FOIL & HOUSING ASSEMBLY, UPPER AIR BEARING
-5	NOTE	95870205							. 'O' RING, SILICON -----*-----
-6	NOTE	95967710							. TRANSDUCER PRESS, SOLID STATE -attaching parts-
-7	NC	92815107							. SCREW, CAP SOC HD, 4-40 x 1.0
-8	NC	10125603							. WASHER, PLAIN 4
-9	NC	10125801							. WASHER, SPRING LOCK 4
-10	NC	77025281							. ISOLATOR, SPRING GUIDE

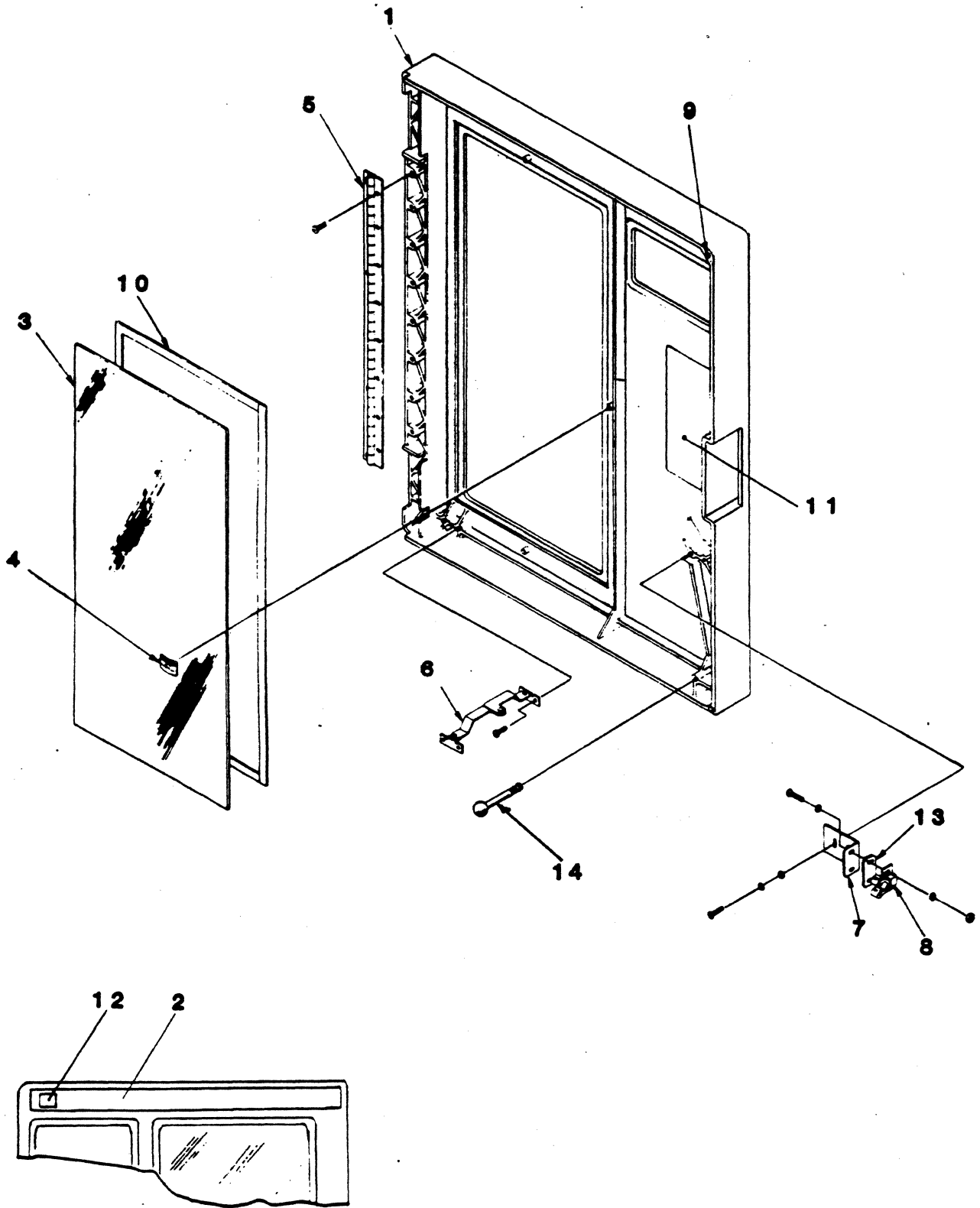

Figure 7-1. Equipment Assembly, Front View

<u>INDEX NO.</u>	<u>PART CODE</u>	<u>PART NUMBER</u>	<u>DESCRIPTION</u>
1-	CNS	7701575X	DOOR ASSEMBLY - VERTICAL
-1	CNS	77013951	. DOOR, VERTICAL - SEAFOAM WHITE
-1	CNS	77013952	. DOOR, VERTICAL - LT. GRAY
-1	CNS	77013953	. DOOR, VERTICAL - IVORY
-1	CNS	77013955	. DOOR, VERTICAL - BLACK
-1	CNS	77013956	. DOOR, VERTICAL - WHITE
-1	CNS	77013957	. DOOR, VERTICAL - BEIGE
-1	CNS	77013961	. DOOR, VERTICAL - GRAY
-2	NC	77006631	. DECORATIVE TRIM - IMPERIAL BLUE (Tab 52 only)
-2	NC	77006632	. DECORATIVE TRIM - BLACK (Tab 53 only)
-2	NC	77006633	. DECORATIVE TRIM - BROWN (Tab 51 only)
-3	NC	77005081	. WINDOW, DOOR
-4	NC	93864267	. FASTENER, PUSH-IN
-5	NC	77005090	. HINGE - CONTINUOUS
-6	NC	49984642	. MECH. ASSY - HINGE STAY UPPER
-7	NC	77013910	. BRACKET, LATCH
-8	NC	92574001	. CATCH, ROLLER FRICTION
-9	NC	77016320	. PAD, SELF ADHESIVE
-10	NC	95968381	. TAPE-FOAM, DOUBLE FACE ADHESIVE .031 X .19
-11	NC	77019823	. LABEL, FAULT RECOVERY
-12	NC	77005514	. PRODUCT IDENT EMBLEM (Tab 52 only)
-13	NC	77015660	. SPACER (All except Tabs 56 & 57)
-14	NC	77010091	. STUD, DOOR

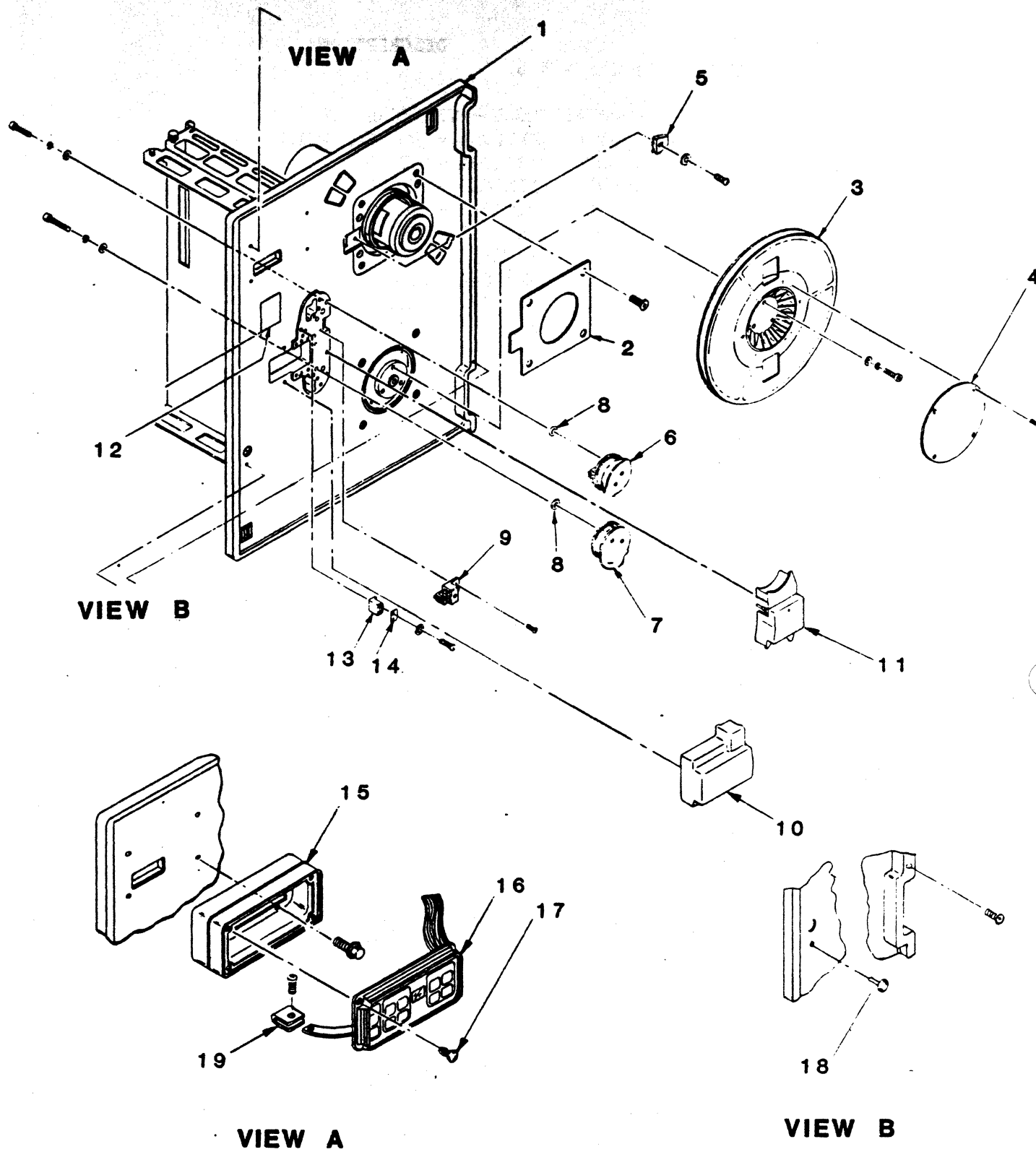

Figure 7-2. Equipment Assembly - Front



<u>INDEX NO.</u>	<u>PART CODE</u>	<u>PART NUMBER</u>	<u>DESCRIPTION</u>					
			1	2	3	4	5	6
2-	NC	7702024X	EQUIPMENT ASSEMBLY - FRONT (50/60 HZ)					
-1	NC	77014361	. TAPE DECK MACH. (BLACK)					
-1	NC	77014362	. TAPE DECK MACH. (WHITE)					
-1	NC	77014363	. TAPE DECK MACH. (BEIGE)					
-2	NC	77014981	. COVER - FILE PROTECT (BLACK)					
-3	*	77003091	. HUB ASSEMBLY - TAKE-UP REEL					
-4	NC	77003790	. COVER - HUB, TAKE-UP REEL					
-5	*	95966083	. SENSOR ASSEMBLY					
-6	CNS	77004213	. AIR BEARING ASSEMBLY - UPPER (See Figure 8)					
-7	CNS	77004333	. AIR BEARING ASSEMBLY - LOWER (See Figure 9)					
-8	*	95870206	. "O" RING, SILICON					
-9	*	77004612	. EOT/BOT ASSEMBLY					
-10	CNS	77011571	. COVER ASSY - MAGNETIC HEAD					
-11	CNS	77011561	. COVER ASSY - TAPE PATH					
-12	NC	77006990	. LABEL - TAPE PATH					
-13	*	77010492	. TAPE CLEANER ASSEMBLY					
-14	NC	77004720	. PLATE; TAPE CLEANER					
-15	*	77014220	. HOUSING - OPERATOR PANEL					
-16	*	77010438	. OPERATOR PANEL GCR					
-17	NC	95968770	. CLIP, PUSH-IN					
-18	CNS	77014130	. DOOR CATCH STRIKE, BALL END					
-19	NC	77009840	. TERMINAL, FOIL GROUNDING					

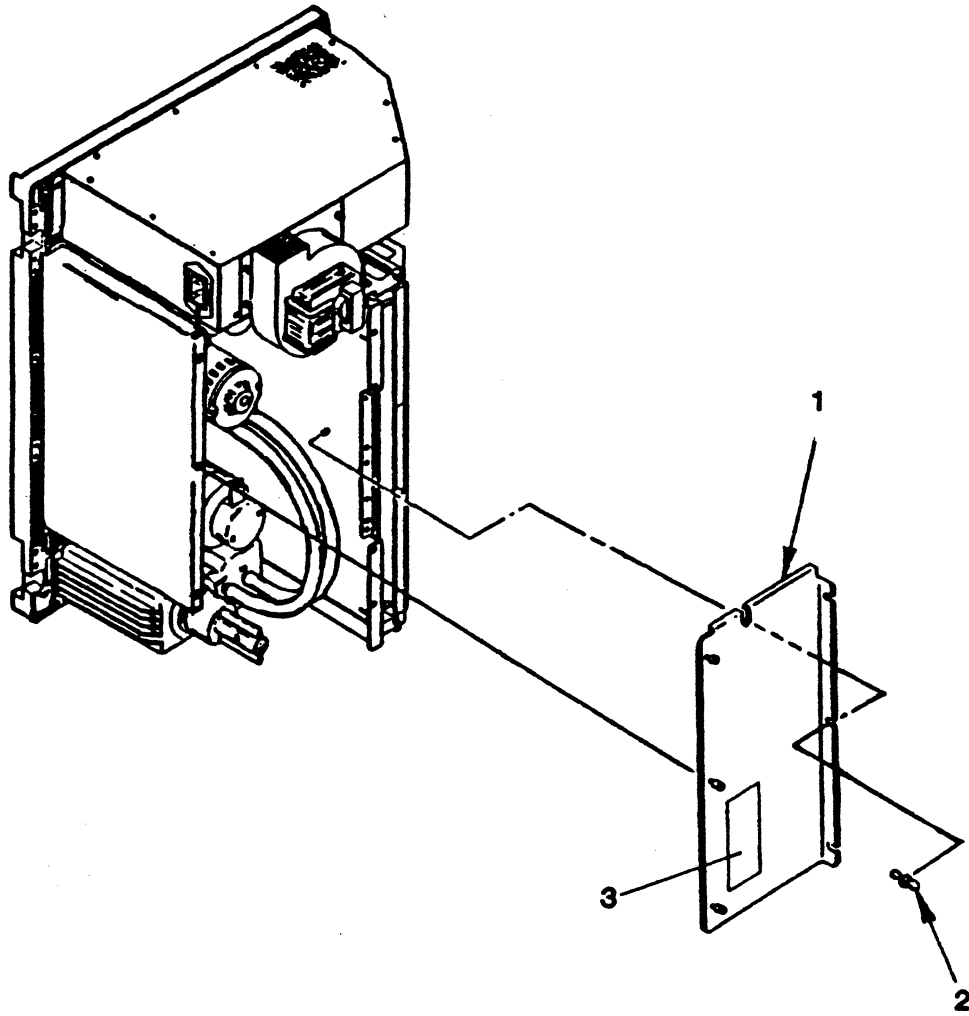

Figure 7-3. Equipment Assembly - Rear

<u>INDEX</u> <u>NO.</u>	<u>PART</u> <u>CODE</u>	<u>PART</u> <u>NUMBER</u>	<u>DESCRIPTION</u>					
			1	2	3	4	5	6
3-	NC	7702024X	EQUIPMENT ASSY - REAR (60/50 HZ)					
-1	NC	77023611	. DRIVE COVER ASSY					
-2	NC	93031001	. NUT - WING (NC) 6-32					
-3	NC	21987646	. LABEL - FCC, RFI, CLASS A, METRIC					
-	NC	77015830	. POWER CORD (60 HZ UNIT ONLY)					
-	NC	95967880	. POWER CONNECTOR (50 HZ UNIT ONLY)					

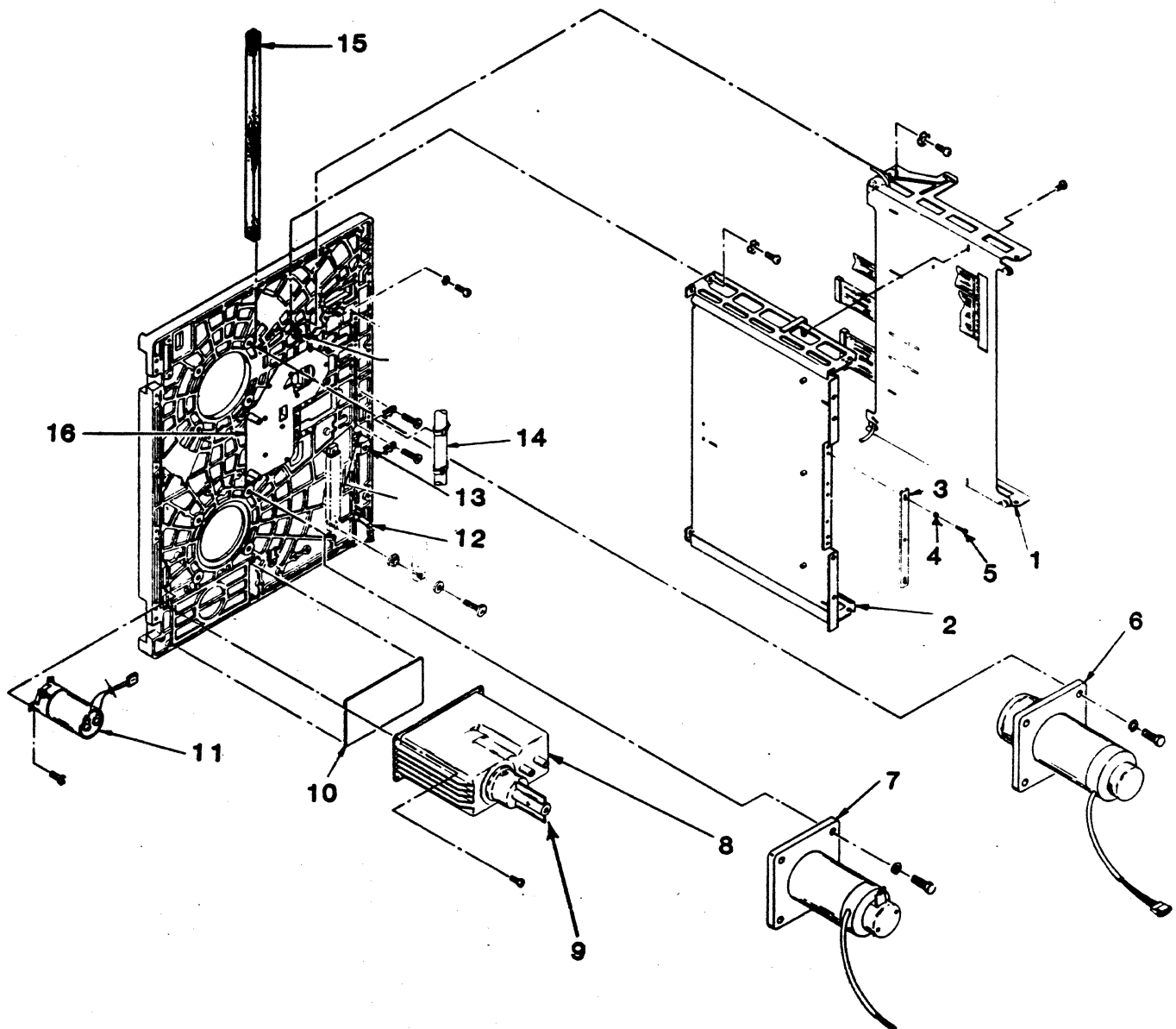

Figure 7-4. Equipment Assembly - Rear

<u>INDEX NO.</u>	<u>PART CODE</u>	<u>PART NUMBER</u>	<u>DESCRIPTION</u>					
			1	2	3	4	5	6
4-	NC	7702024X	EQUIPMENT ASSY - REAR (50/60 HZ)					
-1	NC	77024112	. CAGE ASSEMBLY, DUAL GCR STD OEM					
-2	NC	77018861	. CAGE ASSEMBLY, TRIPLE GCR					
-3	NC	77017195	. STRIP - CLAMP, CA DUAL, 6.72 LG					
-4	NC	10125605	. WASHER PLAIN 6					
-5	NC	95959731	. SCREW - PAN HEAD/EXT TOOTH, LW 6-32 X .750					
-6	*	77006579	. MOTOR ASSEMBLY - SUPPLY REEL					
-7	*	77006162	. MOTOR ASSEMBLY - TAKE UP REEL					
-8	NC	77025191	. AIR CHAMBER ASSEMBLY					
-9	CNS	77011551	. . PRESSURE REGULATOR ASSEMBLY					
-	NC	77015420	. . STUD - HOLLOW					
-10	CNS	77024250	. GASKET - AIR CHAMBER					
-11	NC	77015912	. CAP - CA, 13-17K MF/2 SKT/09LG					
-12	*	95966651	. INTERLOCK SWITCH					
-13	NC	94802306	. FASTENER - ADJ. PAWL					
-14	NC	77023333	. CA - PWR, TTGS 25-75 DC GCR OEM					
-15	NC	77016921	. FOAM STRIP, ADH. .75T, .5W, 14.5L					
-16	NC	77025261	. PLENUM COVER ASSEMBLY					
-	NC	77027453	. CA - PWR TO XDUCER 9.25LG					
-	NC	77015431	. GASKET - FILTER					
-	*	95966090	. . FILTER					

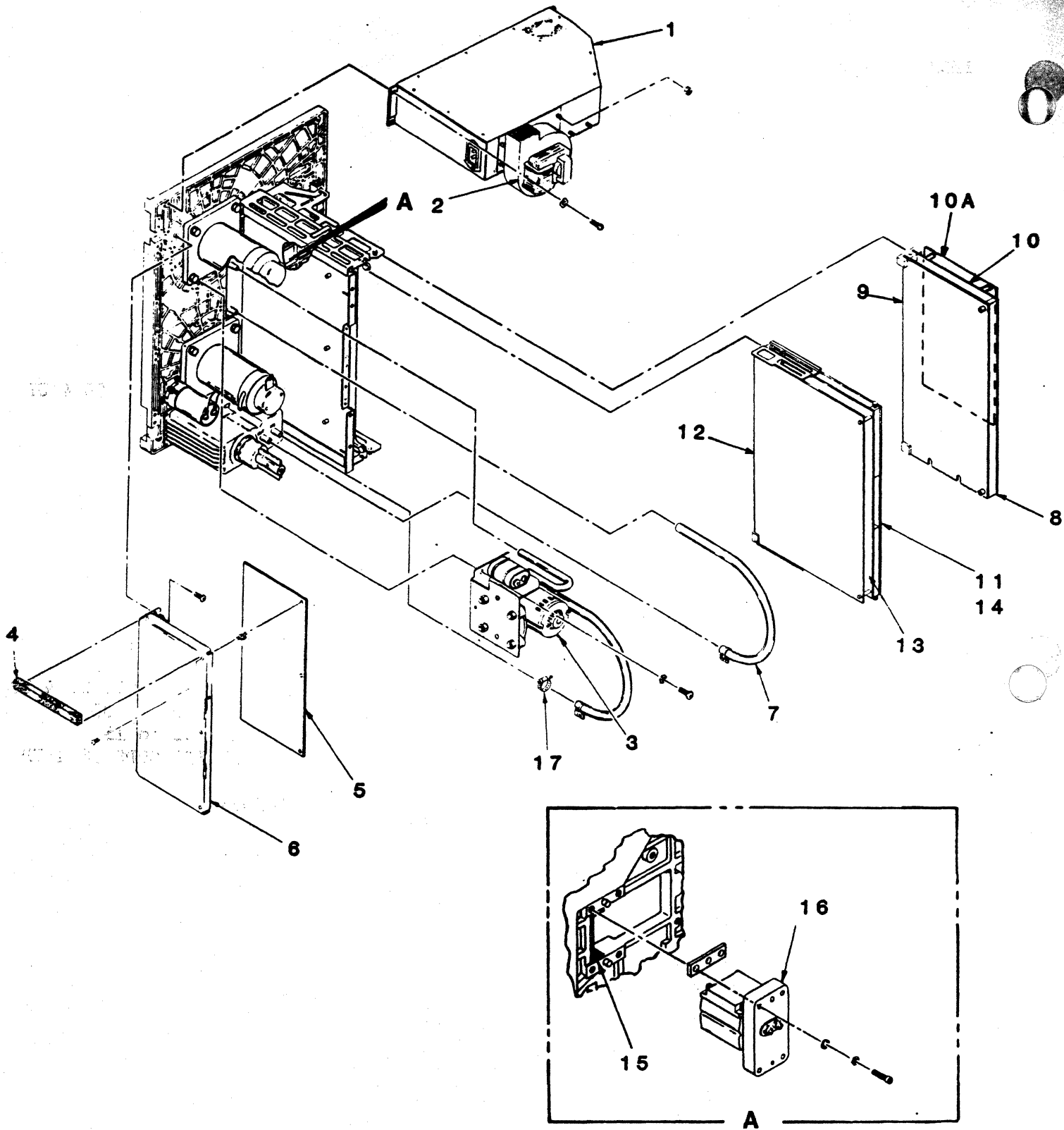

Figure 7-5. Equipment Assembly - Rear

<u>INDEX NO.</u>	<u>PART CODE</u>	<u>PART NUMBER</u>	<u>DESCRIPTION</u>					
			1	2	3	4	5	6
5-	NC	7702024X	EQUIPMENT ASSY - REAR (50/60 HZ)					
-1	*	77018963	. POWER SUPPLY ASSEMBLY 60 HZ SERIES CODE 01-16					
-1	*	77018964	. POWER SUPPLY ASSEMBLY 50 HZ SERIES CODE 01-16					
-1	*	77029341	. POWER SUPPLY ASSEMBLY 60 HZ SERIES CODE 17 & UP					
-1	*	77029342	. POWER SUPPLY ASSEMBLY 50 HZ SERIES CODE 17 & UP					
-2	*	95968431	. BLOWER					
-3	NC	77011537	. COMPRESSOR ASSEMBLY, BRACKET AND CAP, 50/60 HZ					
-4	NC	77016920	. FOAM STRIP, ADHESIVE 0.75T, .50W, 7.5L					
-5	*	7704119X	. PWA - POWER DRIVER 10 AMP					
-6	NC	77023560	. BRACKET - PWR AMP (PWA Mtg)					
-7	NC	77011934	. TUBING - PVC .500, .31ID, 22.0L					
-8	NC	77011519	. CARD SET ASSEMBLY 25/75 IPS					
-9	*	7702593X	. . PWA-SRVO/CNTRL w/PROMS ENH/OEM SERIES CODE 08 & UP					
-9	*	7704223X	. . PWA - SERVO/CONTROL - SERIES CODE 01 to 07					
-10	*	7704122X	. . PWA - READ AMPLIFIER					
-10A	*	7704121X	. . PWA - WRITE DRIVER					
-11	NC	77018152	. CARD SET - TRIPLE GCR w/STD INTERFACE					
-12	*	7704141X	. . PWA - PERTEC INTERFACE					
-12	*	7704247X	. . PWA - BFRD PERTEC I/O (BY3H6C,D,G,H ONLY)					
-12	*	7704264X	. . PWA - BFRD PERTEC I/O (BY3H6A,B ONLY)					
-12	*	7704235X	. . PWA - BFRD STC I/O (BY3J6A,B,C,D,E ONLY)					
-12	*	7704241X	. . PWA - BFRD PERTEC ENHANCED I/O (BY3L6A,B ONLY)					
-12	*	7702892X	. . PWA - BFRD STC ENH I/O (BY3K6A,B,L ONLY)					
-12	*	7704242X	. . PWA - BFRD STC ENH I/O (BY3K6C,D,E,F ONLY)					
-12	*	7704278X	. . PWA - BFRD STC ENH I/O (BY3K6J,K ONLY)					
-13	*	77025962	. . PWA - FORMATTER/WRITE w/PROMS - SERIES CODE 08 & UP					
-13	*	7704124X	. . PWA - FORMATTER/WRITE - SERIES CODE 01 to 07					
-14	*	7704118X	. . PWA - FORMATTER/READ - SERIES CODE 01 to 15					
-14	*	77028111	. . PWA - FORMATTER/READ w/PROMS - SERIES CODE 16 & UP					
-15	NC	77007090	. LINER SILICONE FOAM RUBBER					
-16	NC	77021291	. WRITE CURRENT LABEL + R/W HEAD ASSY (Series Code 01 to 07)					
-16	*	77025380	. MAGNETIC HEAD ASSY - 9 TRK R/W/E GCR (Series Code 08 and above)					

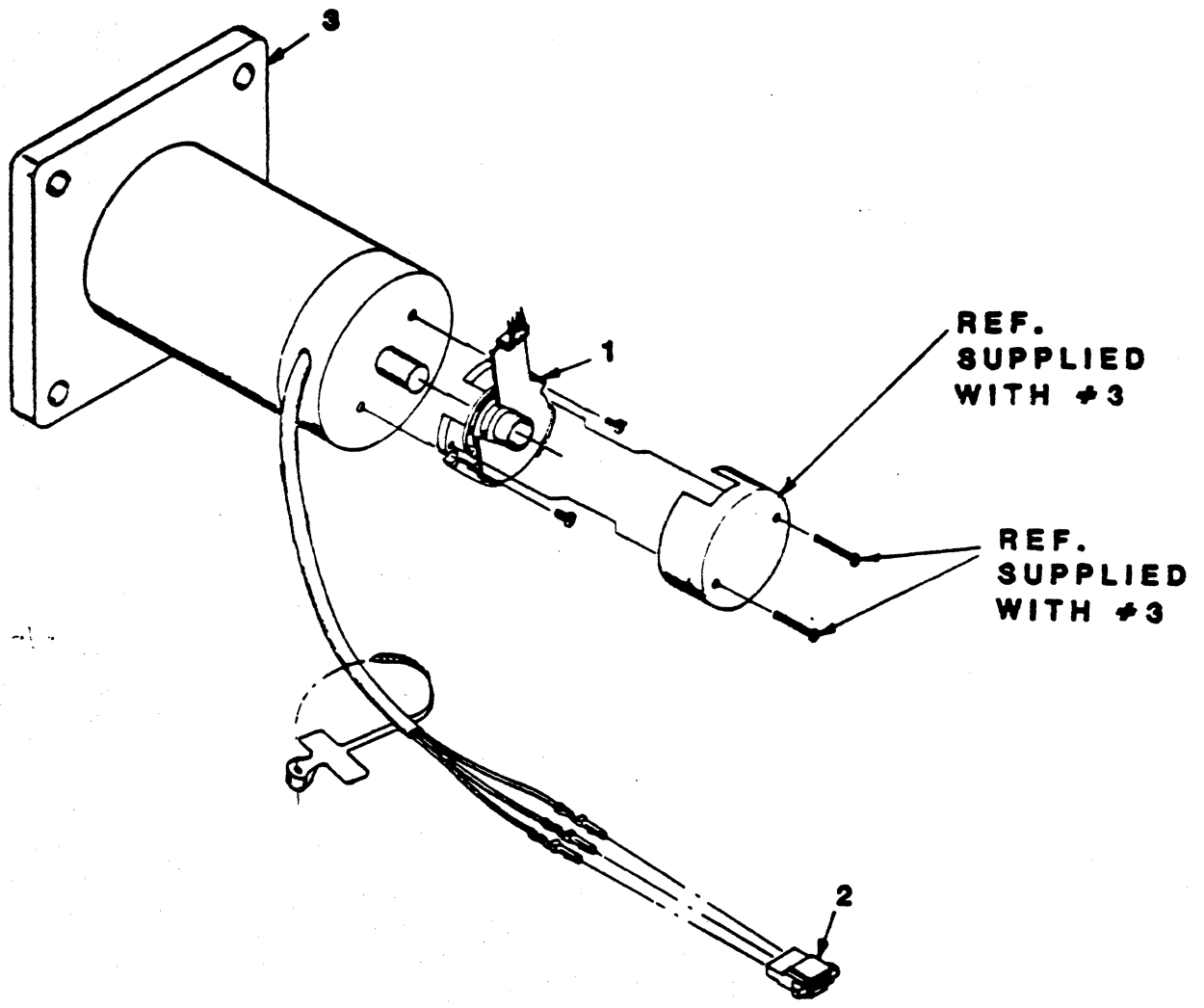

Figure 7-6. Motor Assembly, Take-up Reel



<u>INDEX</u> <u>NO.</u>	<u>PART</u> <u>CODE</u>	<u>PART</u> <u>NUMBER</u>	1	2	3	4	5	6	DESCRIPTION
6-	*	77006162							MOTOR ASSEMBLY, TAKE-UP REEL
-1	NC	95966061							. TACHOMETER, 1000 LINE
-2	NC	95929001							. CONNECTOR, HOUSING, PIN/SOCKET
-3	NC	77015532							. MOTOR ASSEMBLY, REEL

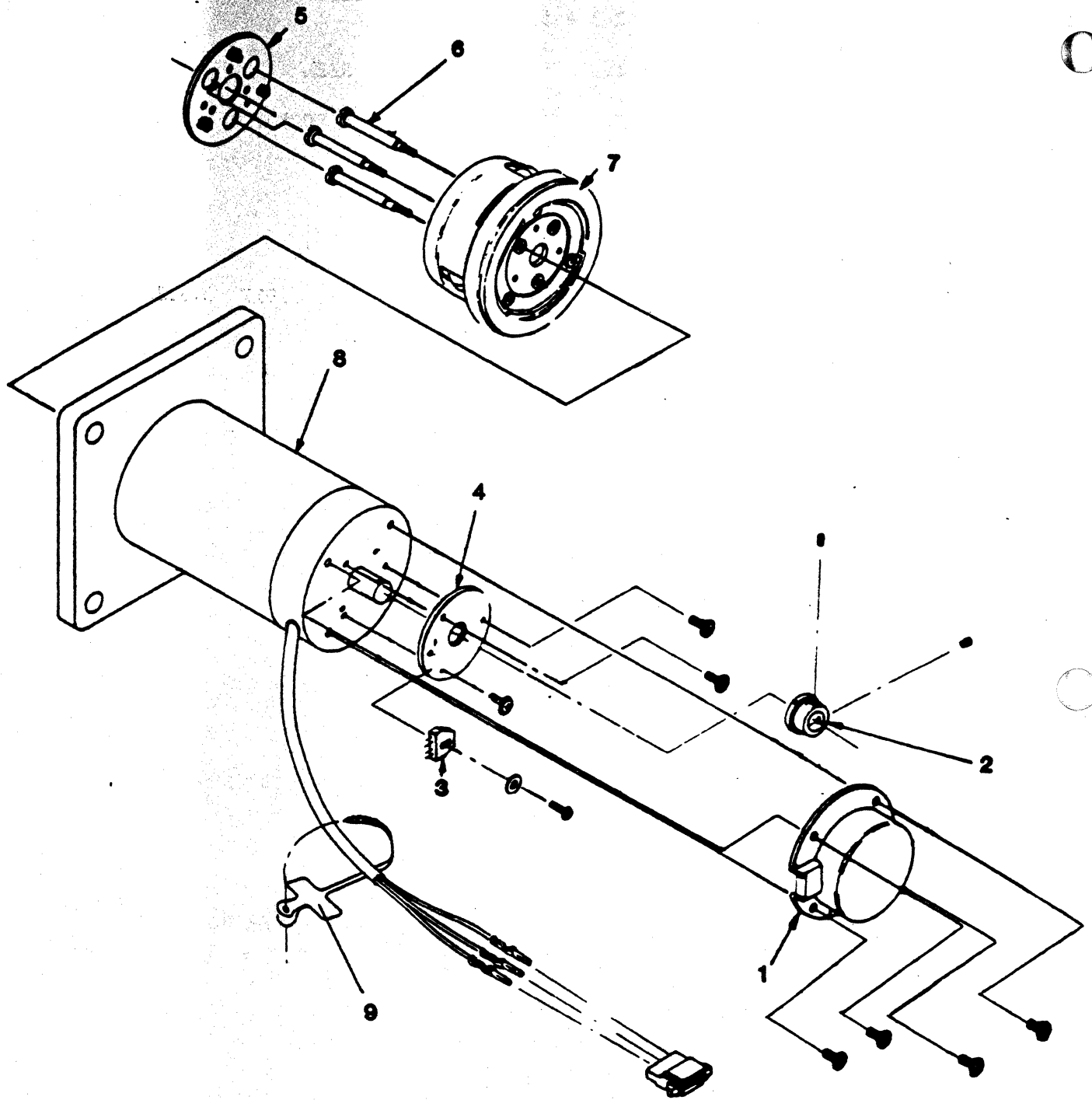
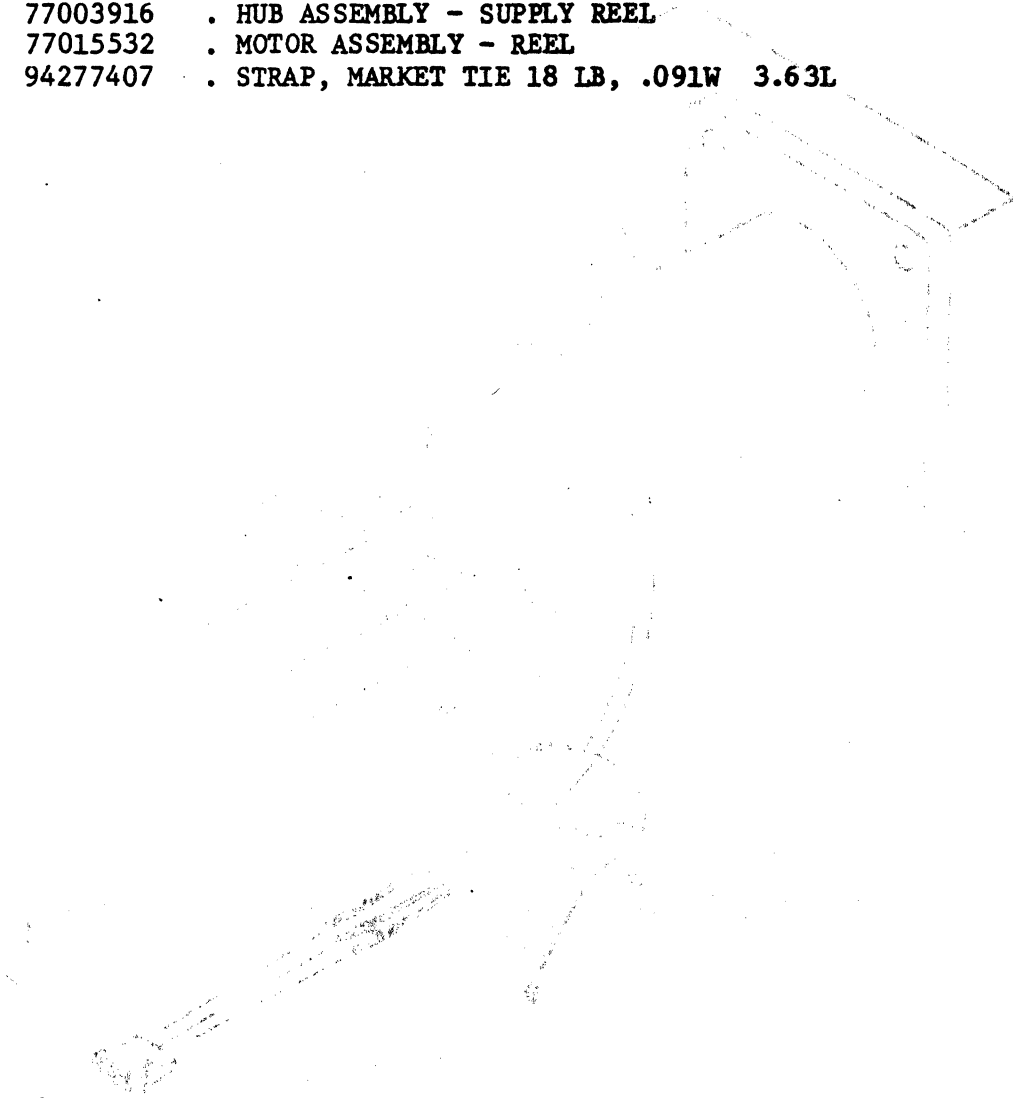

Figure 7-7. Motor Assembly, Supply Reel

<u>INDEX NO.</u>	<u>PART CODE</u>	<u>PART NUMBER</u>	<u>DESCRIPTION</u>					
			1	2	3	4	5	6
7-	*	77006579	MOTOR ASSEMBLY, SUPPLY REEL					
-1	NC	77002240	.	COVER, TACHOMETER				
-2	*	77007560	.	HUB ASSEMBLY - TACHOMETER				
-3	*	95966082	.	SENSOR ASSEMBLY				
-4	NC	77002230	.	PLATE, MOUNTING, SENSOR				
-5	NC	77029241	.	COVER - SUPPLY REEL HUB				
-6	NC	77003970	.	SCREW, SHOULDER				
-7	*	77003916	.	HUB ASSEMBLY - SUPPLY REEL				
-8	*	77015532	.	MOTOR ASSEMBLY - REEL				
-9	NC	94277407	.	STRAP, MARKET TIE 18 LB, .091W 3.63L				



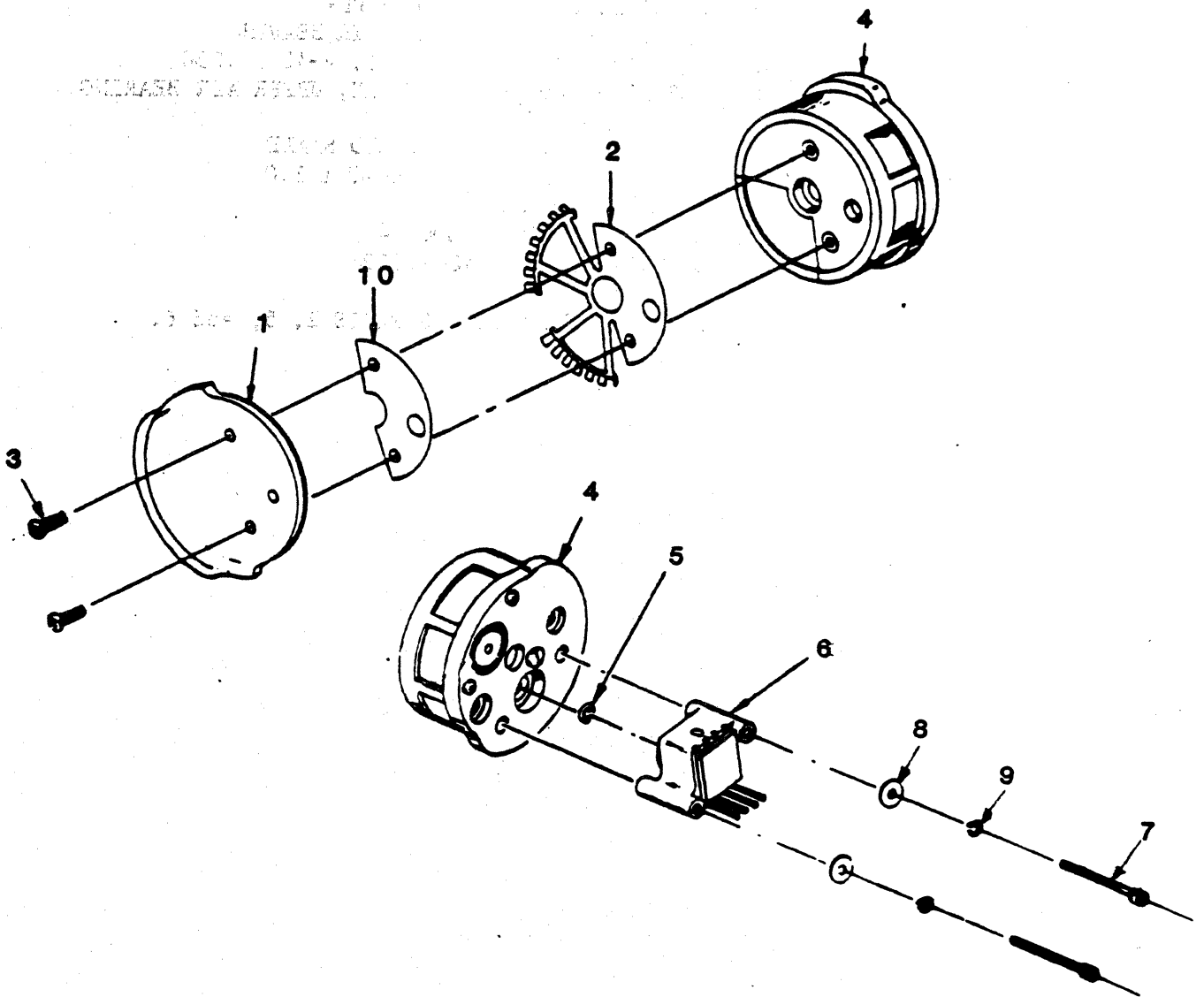

Figure 7-4. Air Bearing Assembly - Upper

INDEX NO.	PART CODE	PART NUMBER	DESCRIPTION					
			1	2	3	4	5	6
8-	CNS	77004215	AIR BEARING ASSEMBLY - UPPER					
-1	NC	77005020	. GUARD, SPRING GUIDE UPPER					
-2	NOTE	77004255	. GUIDE - TAPE, SPRING AIR BEARING					
-3	NC	92748082	. SCREW, MACH PAN HD PHL, 4-40 x .250					
-4	NC	77004241	. FOIL & HOUSING ASSEMBLY, UPPER AIR BEARING					
-5	NOTE	95870205	. 'O' RING, SILICON					
-6	NOTE	95967710	. TRANSDUCER PRESS, SOLID STATE					
-7	NC	92815107	. SCREW, CAP SOC HD, 4-40 x 1.0					
-8	NC	10125603	. WASHER, PLAIN 4					
-9	NC	10125801	. WASHER, SPRING LOCK 4					
-10	NC	77025281	. ISOLATOR, SPRING GUIDE					

\* NOTE - KIT, AIR BEARING P/N 77015961 HAS PARTS 2, 5, and 6.

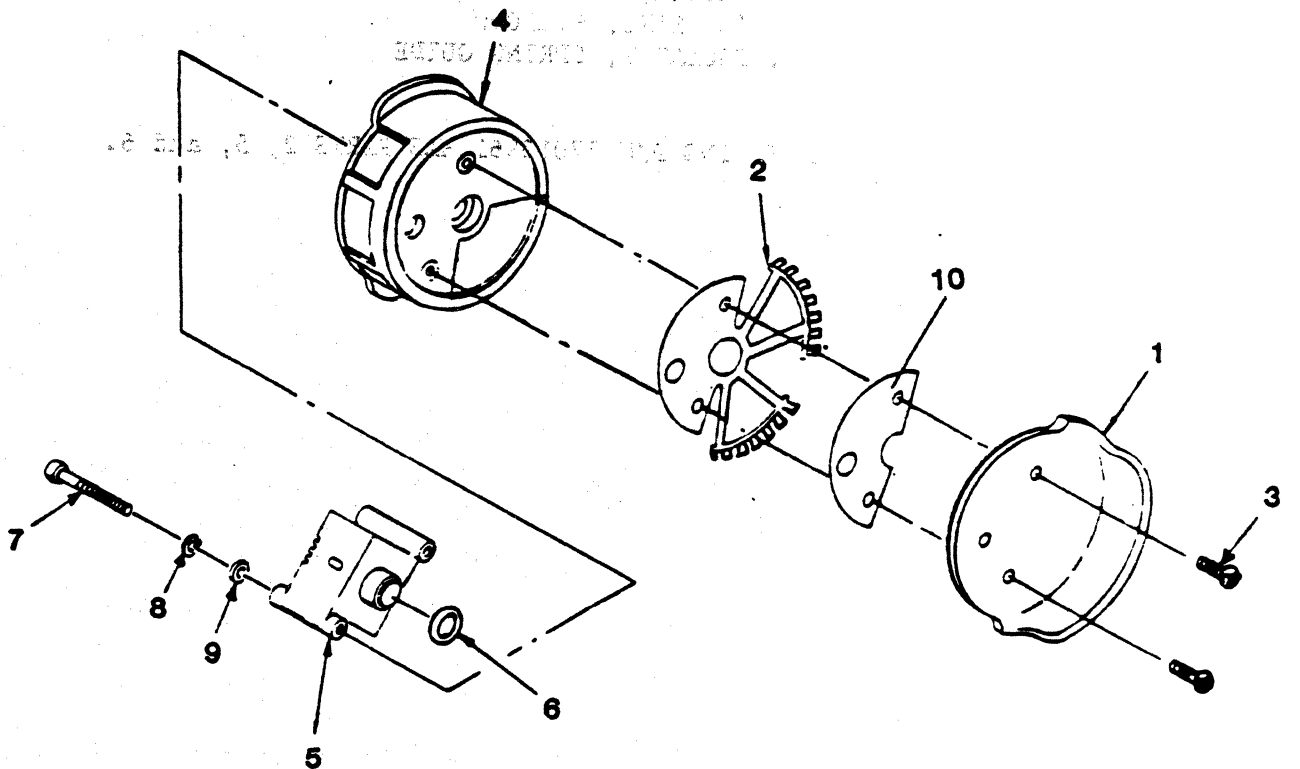
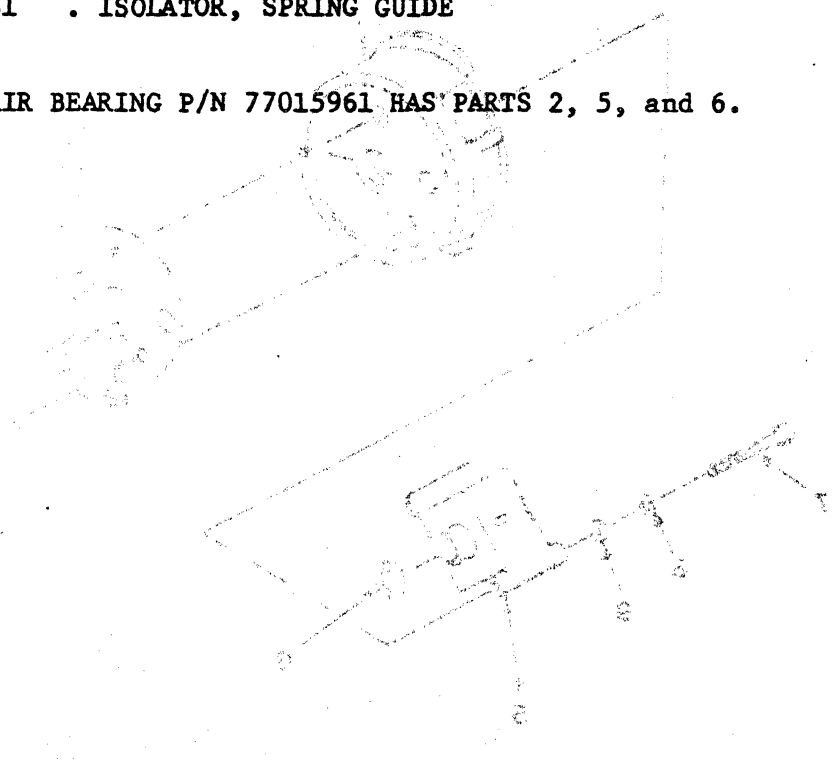

Figure 7-9. Air Bearing Assembly - Lower

\* NOTE - Kit, Air Bearing P/N 77015961 has parts 2, 5, 6 & 7

INDEX NO.	PART CODE	PART NUMBER	DESCRIPTION					
			1	2	3	4	5	6
9-	CNS	77004335	AIR BEARING ASSEMBLY - LOWER					
-1	NC	77005030	.	GUARD SPRING GUIDE LOWER				
-2	NOTE	77004254	.	GUIDE - TAPE, SPRING AIR BEARING				
-3	NC	92748082	.	SCREW, MACHINE PAN HD PHL, 4-40 x .250				
-4	NC	77004361	.	FOIL & HOUSING ASSEMBLY, LOWER AIR BEARING				
-5	NOTE	95967710	.	TRANSDUCER PRESS SOLID STATE				
-6	NOTE	95870205	.	'O' RING, SILICON				
-7	NC	92815107	.	SCREW, CAP, SOC HD, 4-40 x 1.0				
-8	NC	10125801	.	WASHER, SPRING LOCK 4				
-9	NC	10125603	.	WASHER, PLAIN 4				
-	NC	95870206	.	'O' RING, SILICON				
-10	NC	77025281	.	ISOLATOR, SPRING GUIDE				

\* NOTE - KIT, AIR BEARING P/N 77015961 HAS PARTS 2, 5, and 6.



PRINTED WIRING ASSEMBLIES

Table 7-1. PWA Complement

<u>PART NO.</u>	<u>PART CODE</u>	<u>PWA TYPE</u>
7704119X	*	PWA - POWER DRIVER 10 AMP
7702593X	*	PWA - SERVO/CNTRL w/PROMS - ENH/OEM SERIES CODE 08 & UP
7704223X	*	PWA - SERVO/CONTROL - SERIES CODE 01 to 07
7704122X	*	PWA - READ AMPLIFIER
7704121X	*	PWA - WRITE DRIVER
7704141X	*	PWA - PERTEC INTERFACE
7704247X	*	PWA - BFRD PERTEC I/O (BY3H6C,D,G,H ONLY)
7704264X	*	PWA - BFRD PERTEC I/O (BY3H6A,B ONLY)
7704235X	*	PWA - BFRD STC I/O (BY3J6A,B,C,D,E ONLY)
7704241X	*	PWA - BFRD PERTEC ENHANCED I/O (BY3L6A,B ONLY)
7702892X	*	PWA - BFRD STC ENH I/O (BY3K6A,B,L ONLY)
7704242X	*	PWA - BFRD STC ENH I/O (BY3K6C,D,E,F ONLY)
7704278X	*	PWA - BFRD STC ENH I/O (BY3K6J,K ONLY)
77025962	*	PWA - FORMATTER/WRITE w/PROMS - SERIES CODE 08 & UP
7704124X	*	PWA - FORMATTER/WRITE - SERIES CODE 01 to 07
7704118X	*	PWA - FORMATTER/READ - SERIES CODE 01 to 15
7702811X	*	PWA - FORMATTER/READ w/PROMS - SERIES CODE 16 & UP

NOTE

See Section 5, Table 5-1, for illustrations of printed wiring assemblies.



CABLE ASSEMBLIES

Table 7-2. Cable Assemblies

<u>PART NO.</u>	<u>PART CODE</u>	<u>DESCRIPTION</u>	DELT	TIME
77015562	*	CABLE ASSEMBLY - W5, WRITE HEAD		
77021041	*	CABLE ASSEMBLY - W6, READ HEAD		
77013531	CNS	CABLE ASSEMBLY - W2	*	7821000
77023333	CNS	CABLE ASSEMBLY - W7	*	7821000
77015830	CNS	CABLE ASSEMBLY - AC POWER, CBI/PS-PWA	*	7821000
77027451	CNS	CABLE ASSEMBLY - W9	*	7821000
77027452	CNS	CABLE ASSEMBLY - W1	*	7821000
77013593	CNS	CABLE ASSEMBLY - W12	*	7821000
77013542	CNS	CABLE ASSEMBLY - W10 (USED ON PIVOT TYPE R/W CAGE)	*	7821000
77024151	CNS	CABLE ASSEMBLY - W10 (USED ON SLIDE TYPE R/W CAGE)	*	7821000
77013522	CNS	CABLE ASSEMBLY - W3	*	7821000
77015892	CNS	CABLE ASSEMBLY - C1P1	*	7821000
77018543	CNS	CABLE ASSEMBLY - W8, OPER. PNL	*	7821000
76992342	CNS	GROUND CABLE	*	7821000

END

... ..

[Faint, illegible text lines]

Section 101 of the Code shall be interpreted as follows: The purpose of this section is to provide for the... [Faint, illegible text]

# COMMENT SHEET

MANUAL TITLE \_\_\_\_\_

\_\_\_\_\_

PUBLICATION NO. \_\_\_\_\_ REVISION \_\_\_\_\_

FROM: NAME: \_\_\_\_\_

BUSINESS  
ADDRESS: \_\_\_\_\_

## COMMENTS:

This form is not intended to be used as an order blank. Your evaluation of this manual will be welcomed by Computer Peripherals Incorporated. Any errors, suggested additions or deletions, or general comments may be made below. Please include page number references and fill in publication revision level as shown by the last entry on the Record of Revision page at the front of the manual. Customer engineers are urged to use the TAR.

CUT ALONG LINE

NO POSTAGE STAMP NECESSARY IF MAILED IN U. S. A.

FOLD

FOLD

19403-9990

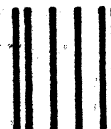

NO POSTAGE  
NECESSARY  
IF MAILED  
IN THE  
UNITED STATES

**BUSINESS REPLY MAIL**  
FIRST CLASS PERMIT NO. 32 NORRISTOWN, PA



POSTAGE WILL BE PAID BY

**COMPUTER PERIPHERALS, INC.**  
**2621 VAN BUREN AVENUE**  
**NORRISTOWN, PENNSYLVANIA 19403**

**ATTN: TECHNICAL PUBLICATIONS DEPT.**

FOLD

FOLD

LONG LINE